



849 NW STATE ROAD 45
 NEWBERRY, FL 32669 USA
 PH: 888.472.2424 OR
 352.472.5500
 FAX: 352.472.2030
 EMAIL: INFO@TIMCOENGR.COM
[HTTP://WWW.TIMCOENGR.COM](http://WWW.TIMCOENGR.COM)

AMPLIFIER

FCC PART 22 TEST REPORT

Applicant	CRESCEND TECHNOLOGIES, LLC
Address	140 E. State Parkway SCHAUMBURG IL 60173 USA
FCC ID	CWWDSDTUL50
Model Number	DSDTUL50
Product Description	UHF AMPLIFIER
Date Sample Received	10/23/2017
Date Tested	12/14/2017
Tested By	Franklin Rose
Approved By	Tim Royer
Test Results	<input checked="" type="checkbox"/> PASS <input type="checkbox"/> FAIL

Report Number	Version Number	Description	Issue Date
1568UT17_PT22_TestReport	Rev1	Initial Issue	01/22/2018
1568UT17_PT22_TestReport	Rev2	Clerical Update	03/09/2018
1568UT17_PT22_TestReport	Rev3	Power Output and AGC Data Updated	05/01/2018

THE ATTACHED REPORT SHALL NOT BE REPRODUCED EXCEPT IN FULL WITHOUT THE WRITTEN APPROVAL OF TIMCO ENGINEERING, INC.

TABLE OF CONTENTS

GENERAL REMARKS	4
EUT DESCRIPTION	5
TEST RESULTS SUMMARY.....	6
FREQUENCY TEST PLAN	7
RF POWER OUTPUT and AMPLIFIER GAIN. §4.5.....	8
Test Data: Power Output Measurement Table.....	8
AGC THRESHOLD §4.2.....	9
Test Data: AGC Table.....	9
OUT-OF-BAND REJECTION § 4.3	10
Test Data: Out of Band Rejection Plot	10
INPUT-VERSUS-OUTPUT SIGNAL COMPARISON §4.4	11
INPUT-VERSUS-OUTPUT SIGNAL COMPARISON §4.4, 454.500 MHz.....	12
Test Data: 454.500 MHz – 6.25 kHz Test Signal.....	12
Test Data: 454.500 MHz – 6.25 kHz Output Signal	13
Test Data: 454.500 MHz – 12.5 kHz Test Signal.....	14
Test Data: 454.500 MHz – 12.5 kHz Output Signal	15
Test Data: 454.500 MHz – 25 kHz Test Signal.....	16
Test Data: 454.500 MHz – 25 kHz Output Signal	17
Test Data: 454.500 MHz – P25 Phase 1 C4FM Test Signal.....	18
Test Data: 454.500 MHz – P25 Phase 1 C4FM Output Signal	19
Test Data: 454.500 MHz – P25 Phase 2 H-CPM Test Signal	20
Test Data: 454.500 MHz – P25 Phase 2 H-CPM Output Signal	21



INPUT-VERSUS-OUTPUT SIGNAL COMPARISON §4.4, 459.975 MHz..... 22

 Test Data: 459.975 MHz – 6.25 kHz Test Signal..... 22

 Test Data: 459.975 MHz – 6.25 kHz Output Signal 23

 Test Data: 459.975 MHz – 12.5 kHz Test Signal..... 24

 Test Data: 459.975 MHz – 12.5 kHz Output Signal 25

 Test Data: 459.975 MHz – 25 kHz Test Signal..... 26

 Test Data: 459.975 MHz – 25 kHz Output Signal 27

 Test Data: 459.975 MHz – P25 Phase 1 C4FM Test Signal..... 28

 Test Data: 459.975 MHz – P25 Phase 1 C4FM Output Signal..... 29

 Test Data: 459.975 MHz – P25 Phase 2 H-CPM Test Signal 30

 Test Data: 459.975 MHz – P25 Phase 2 H-CPM Output Signal 31

NOISE FIGURE §4.6..... 32

OUT OF BAND / OUT OF BLOCK EMISSIONS §4.7 32

ANTENNA CONDUCTED EMISSIONS §4.7 33

 Test Data: All Test Frequencies (454 – 460 MHz)..... 34

FREQUENCY STABILITY MEASUREMENTS §4.8 35

FIELD STRENGTH OF SPURIOUS RADIATION EMISSIONS §4.9..... 36

 Test Data: 454.5 MHz Radiated Emission Table 36

 Test Data: 459.975 MHz Radiated Emission Table..... 37

EQUIPMENT LIST..... 38

STATEMENT OF MEASUREMENT UNCERTAINTY 39

GENERAL REMARKS

The attached report shall not be reproduced except in full without the written permission of Timco Engineering Inc.

Summary

The device under test does:

- Fulfill the general approval requirements as identified in this test report and was selected by the customer.
- Not fulfill the general approval requirements as identified in this test report

Attestations

This equipment has been tested in accordance with the standards identified in this test report. To the best of my knowledge and belief, these tests were performed using the measurement procedures described in this report.

All instrumentation and accessories used to test products for compliance to the indicated standards are calibrated regularly in accordance with ISO 17025 requirements.

I attest that the necessary measurements were made at:

Timco Engineering Inc.
849 NW State Road 45
Newberry, FL 32669



Tested by:

Name and Title: Franklin Rose, Testing Technician/Project Manager

Date: 12/14/2017



Tested by:

Name and Title: Tim Royer, Engineer

Date: 2/27/2018

Sr. EMC Engineer
EMC-003838-NE



EUT DESCRIPTION

EUT Description	AMPLIFIER
FCC ID	CWWDSDTUL50
Model Number	DSDTUL50
Operating Frequency	454 - 460 MHz
Type of Emission	16K0F3E, 16K0F3D, 11K3F3E, 11K3F3D, 8K10F1E, 8K10F1D, 8K10F1W, 4K00F1E, 4K00F1D, 4K00F2D, 8K30F7W, 7K60FXD, 7K60FXE, and G3E (complies using CW signal, per KDB 935210 s.4.1)
EUT Power Source	<input type="checkbox"/> 110–120Vac/50– 60Hz
	<input checked="" type="checkbox"/> DC Power 13.8 V
	<input type="checkbox"/> Battery Operated Exclusively
Test Item	<input type="checkbox"/> Prototype
	<input type="checkbox"/> Pre-Production
	<input checked="" type="checkbox"/> Production
Type of Equipment	<input checked="" type="checkbox"/> Fixed
	<input type="checkbox"/> Mobile
	<input type="checkbox"/> Portable
Test Conditions	The temperature was 26°C with a relative humidity of 50%.
Revision History to the EUT	None
Test Exercise	The EUT was operated in a normal mode.
Applicable Standards	FCC CFR 47 Part 22, FCC CFR 47 Part 90, KDB 935210 D05 v01r02, 971168 D01 v03, KDB 971168-D03 v01 , ANSI C63.26-2015
Test Facility	Timco Engineering Inc. at 849 NW State Road 45 Newberry, FL 32669 USA. Designation #: US1070

EUT Notes: The EUT is an amplifier which receives RF input signal through a permanently conducted connection. The EUT amplifies when a $\geq +16$ dBm signal is received via this connection. Therefore, a KDB inquiry was filed to exempt a related device from Noise figure measurements, and was accepted by the FCC in KDB inquiry 925403. Furthermore, since the device will never handle multiple signals, another KDB inquiry was filed to exempt a related device from Out-Of-Block Intermodulation testing which was also accepted by the FCC in KDB inquiry 885618. Testing reflects these exemptions.

TEST RESULTS SUMMARY

FCC RULE PART	Limit	TEST DESCRIPTION	RESULT PASS/FAIL
Pt 2.1046(a), Pt. 22.627, KDB 935210-D05 v01r02 §4.5	1000 W ERP	Input/output power	PASS
KDB 935210-D05 v01r02 §4.2	Reporting Only	AGC Threshold	PASS
KDB 935210-D05 v01r02 §4.3	Reporting Only	Out-Of-band rejection	n/a
Pt 90.219(e)(4)(i)(ii)(iii), Pt 90.210, KDB 935210-D05 v01r02 §4.4	Reporting Only	Input-versus-output signal comparison	PASS
KDB 935210-D05 v01r02 §4.6	9 dB	Noise Figure	Exempt per KDB Inquiry 925403
90.210, KDB 935210-D05 v01r02 §4.4	-20.26 dBm	Out-of-band/out-of-block Intermodulation	Exempt per KDB Inquiry 885618
Pt 90.219(e)(3), Pt 90.210, KDB 935210-D05 v01r02 §4.4	-20.26 dBm	Spurious Emissions Conducted	PASS
FCC Pt. 22.355, KDB 935210-D05 v01r02 §4.8	n/a	Frequency Stability	n/a
90.210 & KDB 935210-D05 v01r02 §4.4	-20.26 dBm	Spurious emissions radiated	PASS

Note: The most strict limit possible for this device was used for all measurements which utilize a limit for emissions outside 250% of the bandwidth. This was found by combining the least output power level with the most strict >250% BW dBc limit in 90.210 used by this device. This is expressed as:

454.5 MHz output of 46.75 dBm – 66.99 dBc (Mask D) = -20.26 dBm

FREQUENCY TEST PLAN

Frequency Band	Required Test Place(s) in Band	Test Frequencies (MHz)
Pt. 22: 454 – 455 MHz	1	454. 5
Pt. 22: 456 – 460 MHz	2	456.025, 459.975

RF POWER OUTPUT and AMPLIFIER GAIN. §4.5

Rule Part No.: FCC Parts 22.627, Part 2.1046(a)

Requirements: 1000 W ERP

Procedure: KDB935210 Measurement Guidance for Industrial Boosters
 § 4.5.1 General
 § 4.5.2 Determining Amplifier/Booster Gain
 § 4.5.4 Power Measurement Method 2: Using a power meter

The Input and Output power levels were recorded and the gain calculated using the following formula:

$$\text{Gain}_{\text{dB}} = \text{Output Power}_{\text{dBm}} - \text{Input Power}_{\text{dBm}}$$

Test Data: Power Output Measurement Table, 1 W (Min Input Level)

Mode	Input Freq (MHz)	Input Power (dBm)	Output Power (dBm)	Output Power (W)	Gain (dB)
CW	454.5000	30.00	46.75	47.32	16.75
CW	456.0250	30.00	46.76	47.42	16.76
CW	459.9750	30.00	46.81	47.97	16.81

Test Data: Power Output Measurement Table, 5 W (Max Input Level)

Mode	Input Freq (MHz)	Input Power (dBm)	Output Power (dBm)	Output Power (W)	Gain (dB)
CW	454.5000	36.99	46.80	47.86	9.81
CW	456.0250	36.99	46.81	47.97	9.82
CW	459.9750	36.99	46.81	47.97	9.82

Part 2.1033 (C) (8) DC Input into the final amplifier

INPUT POWER: (13.8 VDC) (12 A) = **165.6 Watts Maximum**

AGC THRESHOLD §4.2

Rule Part No.: KDB935210 § 4.2

Requirements: Reporting only

Procedure: KDB935210 Measurement Guidance for Industrial Boosters
§ 4.2 Measuring AGC threshold

Test Data: AGC Table

Frequency (MHz)	Input Level (dBm)	Booster Output (dBm)
460	28.00	0.0
460	29.00	0.0
460	30.00	47.73
460	31.00	47.73
460	32.00	47.73
460	33.00	47.73
460	34.00	47.73
460	35.00	47.73
460	36.00	47.74
460	37.00	47.74
460	38.00	0.00

Note: Yellow denotes level below AGC; green denotes AGC level +3 dB

Results: The EUT turns on at a fixed input, and transmits at a fixed level. Therefore the EUT does not employ AGC.

OUT-OF-BAND REJECTION § 4.3

Rule Part No.: KDB 935210 §4.3 Out of band rejection
KDB 971168

Requirements: Reporting Only

Procedure: KDB 935210 §4.3 Out of band rejection
KDB 971168

Test Data: Out of Band Rejection Plot

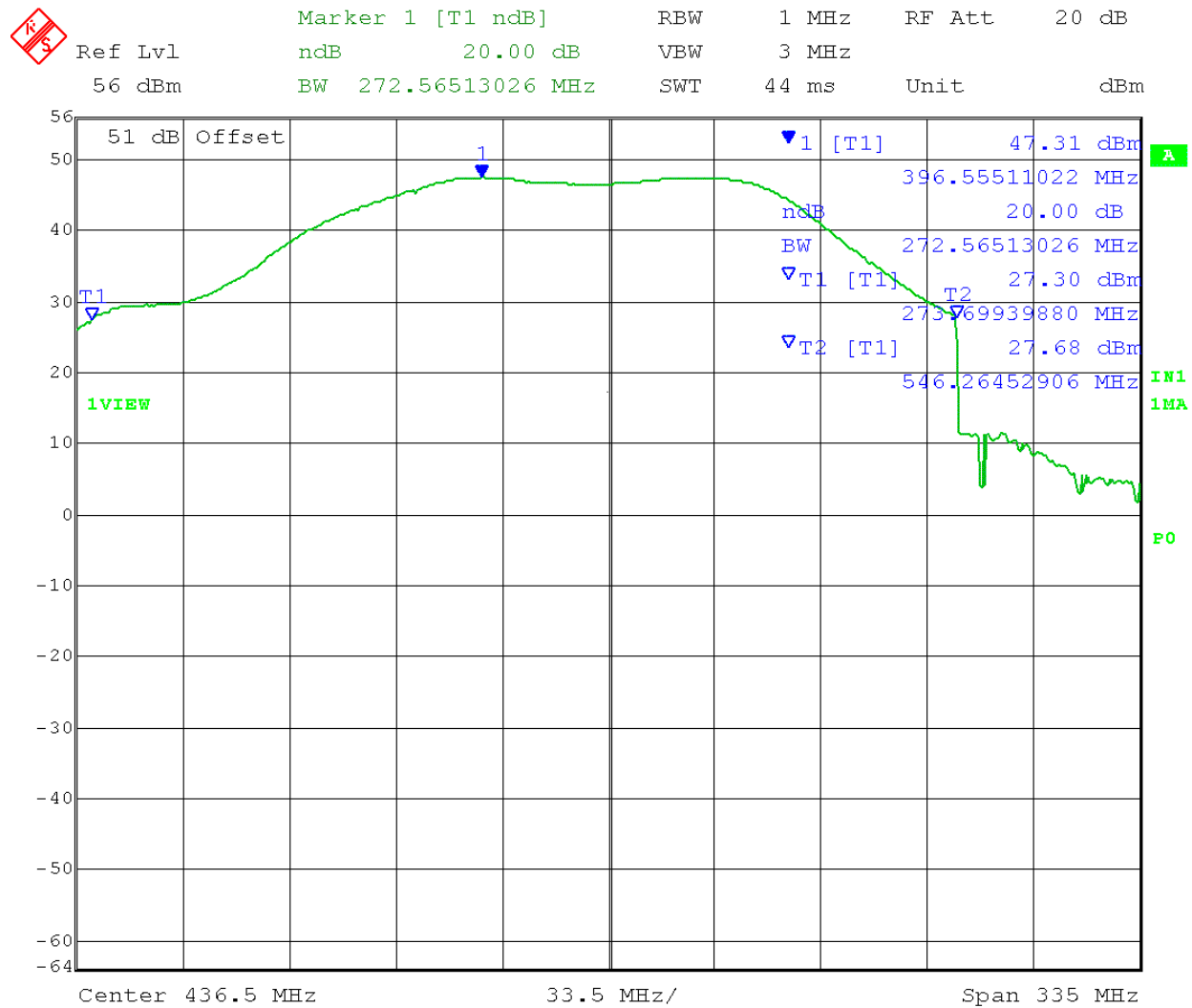

Date: 14.SEP.2017 14:10:50
PASSBAND 20 dB width = 272.57 MHz

Results: N/A. The EUT amplifies all signals which are passed to it, and does not reject signals which are out-of-band.

INPUT-VERSUS-OUTPUT SIGNAL COMPARISON §4.4

Rule Part No.: FCC Pt. 90.210
KDB 935210-D05 v01r02 §4.4
KDB 971168-D01 v03 §4
KDB 971168-D03 v01

Requirements: For devices that are classified as signal boosters under §§ 20.21 or 90.219, please refer to KDB Publication 935210 for the applicable procedures. In addition, for any devices like amplifiers, repeaters, and boosters, a comparison of the input modulated spectrum and the output modulated spectrum are required. This corresponds to the occupied bandwidth test required under § 2.1049.

A signal booster must be designed such that all signals that it retransmits meet the following requirements:

The signals are retransmitted on the same channels as received. Minor departures from the exact provider or reference frequencies of the input signals are allowed.

There is no change in the occupied bandwidth of the retransmitted signals.

The retransmitted signals continue to meet the unwanted emissions limits of §90.210 applicable to the corresponding received signals (assuming that these received signals meet the applicable unwanted emissions limits by a reasonable margin).

Procedure: KDB935210 § 4.4 - Input versus output signal comparison
KDB 971168-D01 v03 §4 - The relative OBW must be measured and reported when it is specified in the applicable rule part;
Otherwise, the 99 % OBW shall be measured and reported.

INPUT-VERSUS-OUTPUT SIGNAL COMPARISON §4.4, 454.500 MHz

Test Data: 454.500 MHz – 6.25 kHz Test Signal

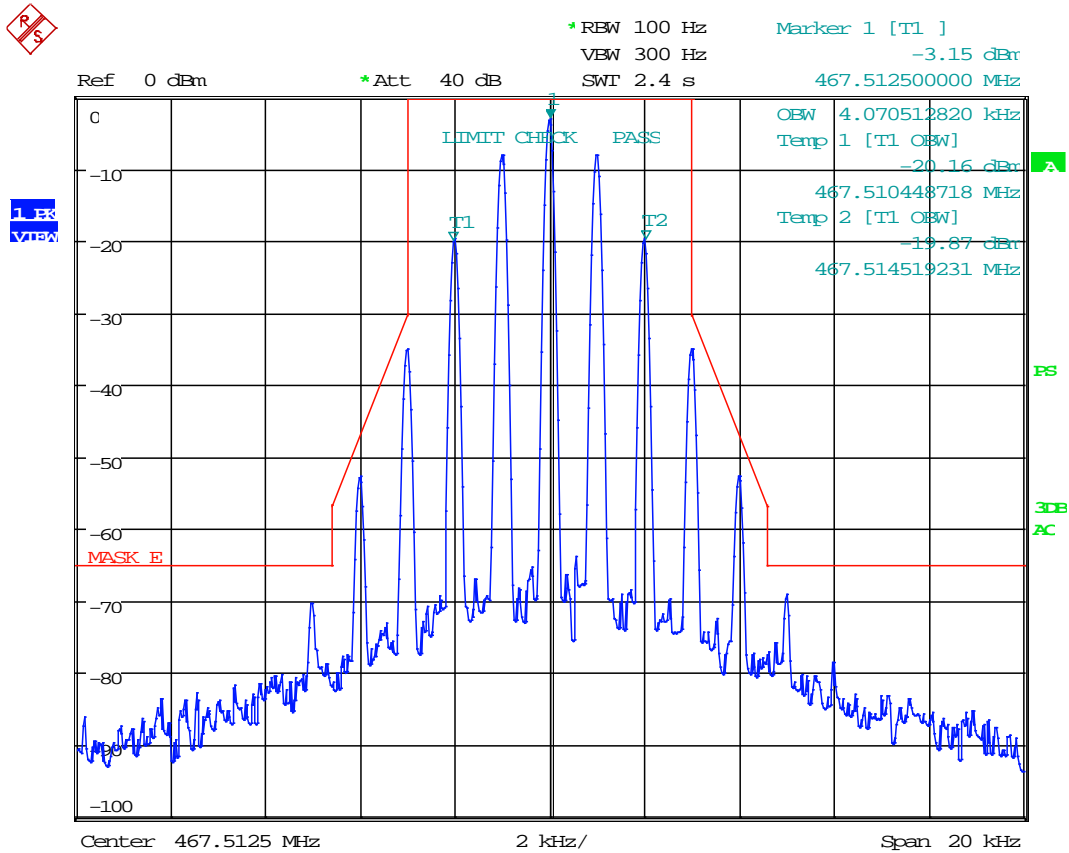

Date: 18.DEC.2017 15:10:34

INPUT-VERSUS-OUTPUT SIGNAL COMPARISON §4.4

Test Data: 454.500 MHz – 6.25 kHz Output Signal

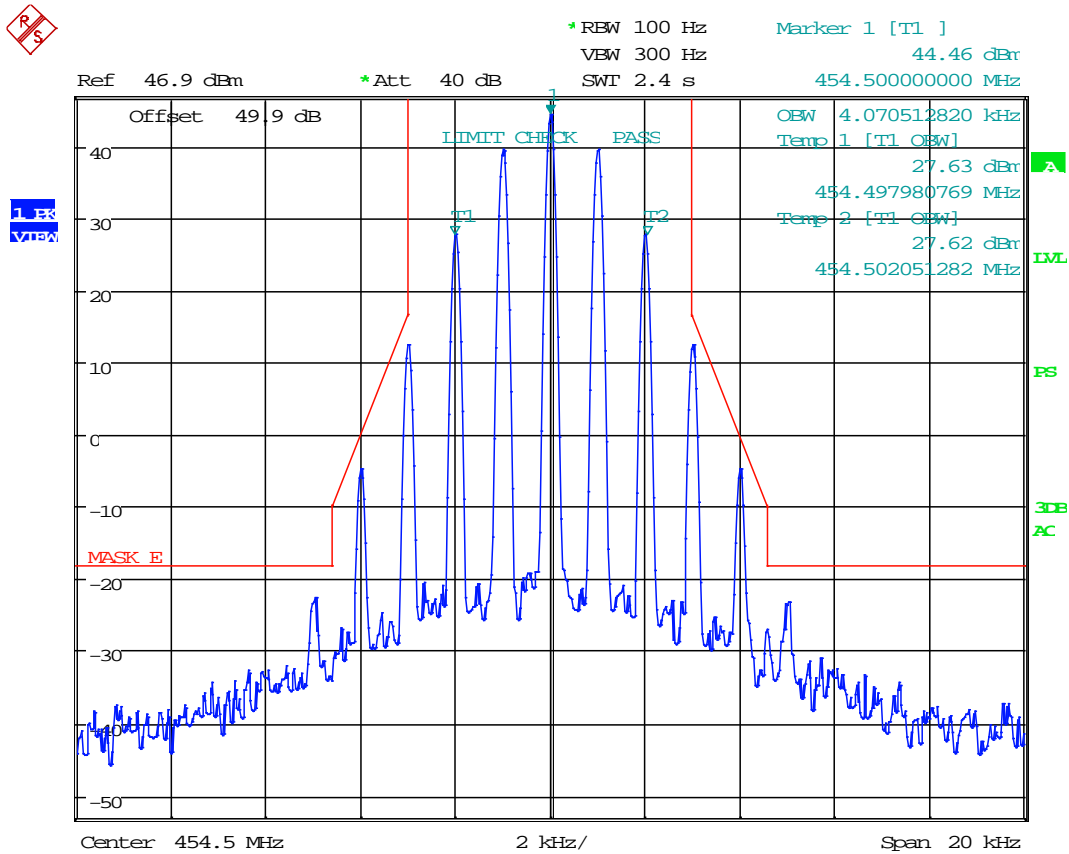

Date: 18.DEC.2017 15:48:47

INPUT-VERSUS-OUTPUT SIGNAL COMPARISON §4.4

Test Data: 454.500 MHz – 12.5 kHz Test Signal

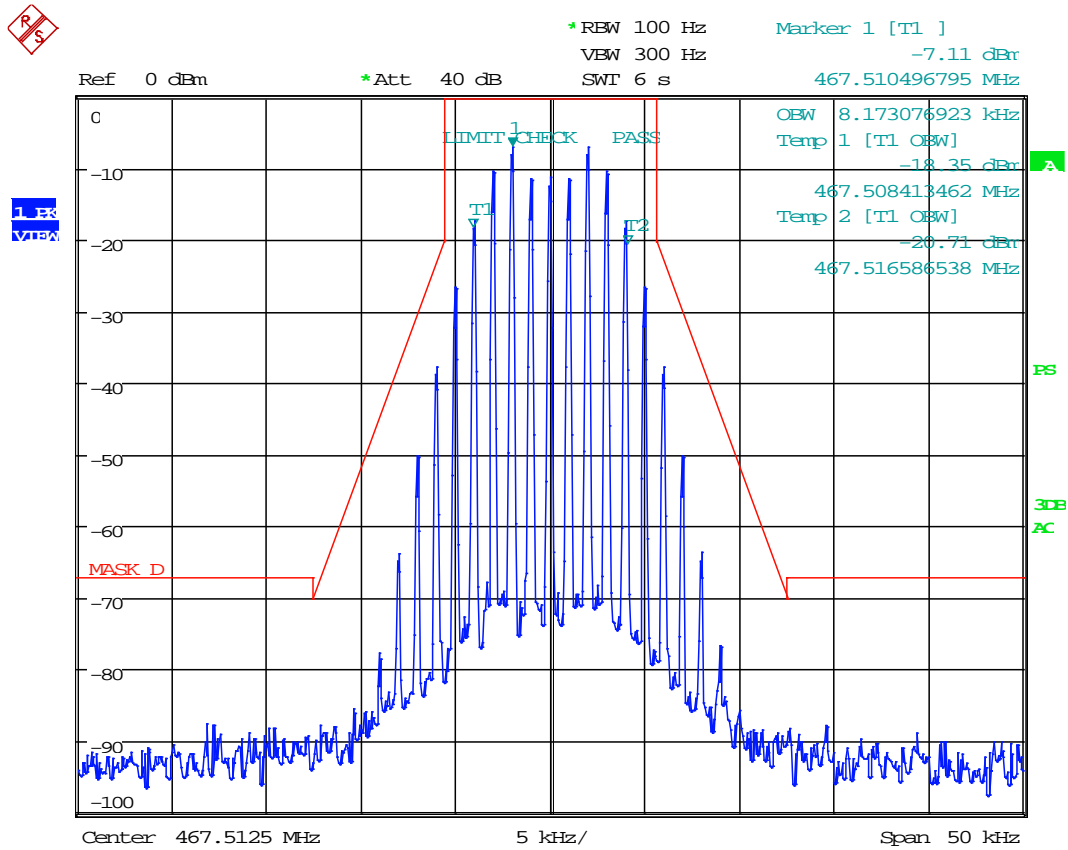

Date: 18.DEC.2017 15:12:10

INPUT-VERSUS-OUTPUT SIGNAL COMPARISON §4.4

Test Data: 454.500 MHz – 12.5 kHz Output Signal

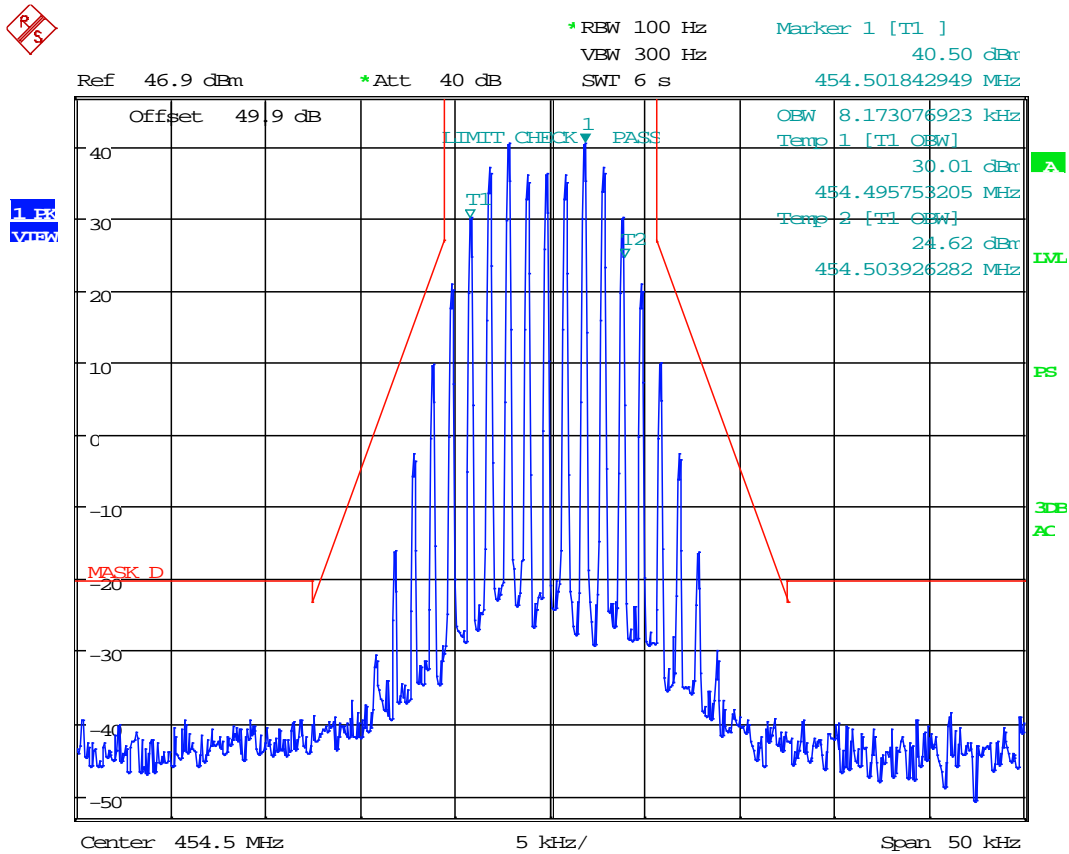

Date: 18.DEC.2017 15:30:40

INPUT-VERSUS-OUTPUT SIGNAL COMPARISON §4.4

Test Data: 454.500 MHz – 25 kHz Output Signal

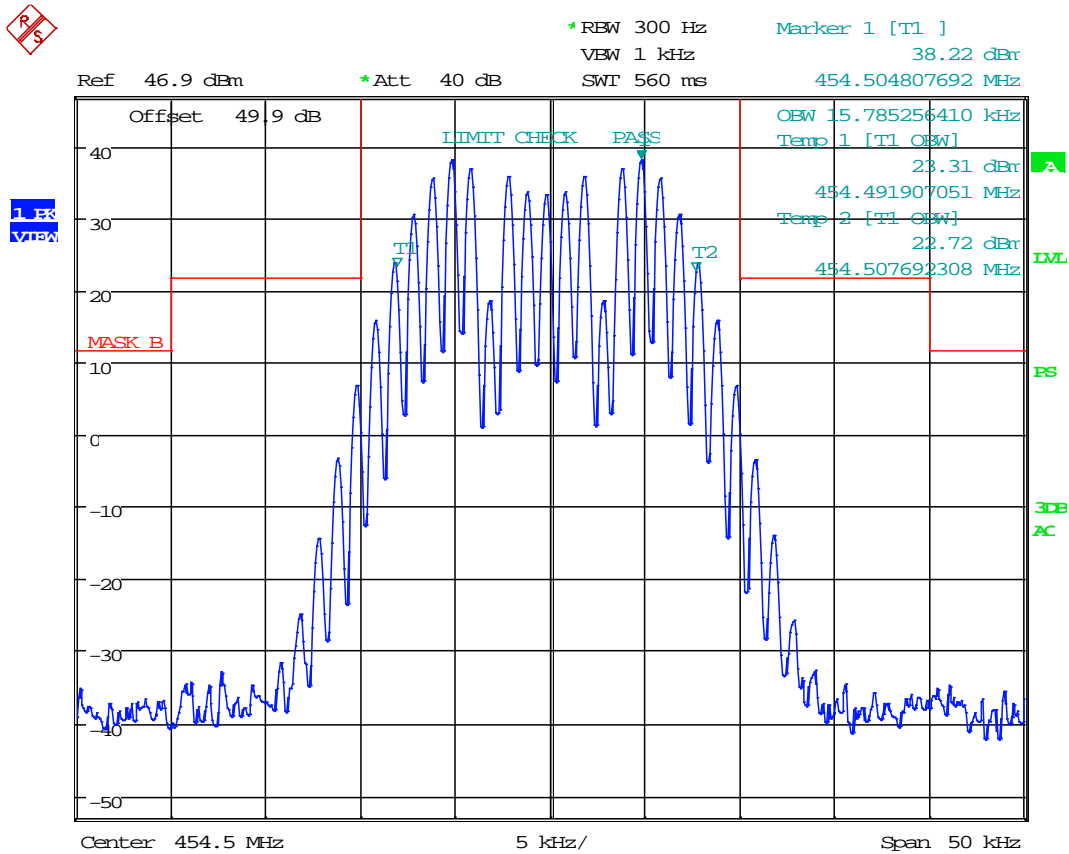

Date: 18.DEC.2017 15:38:36

INPUT-VERSUS-OUTPUT SIGNAL COMPARISON §4.4

Test Data: 454.500 MHz – P25 Phase 1 C4FM Test Signal

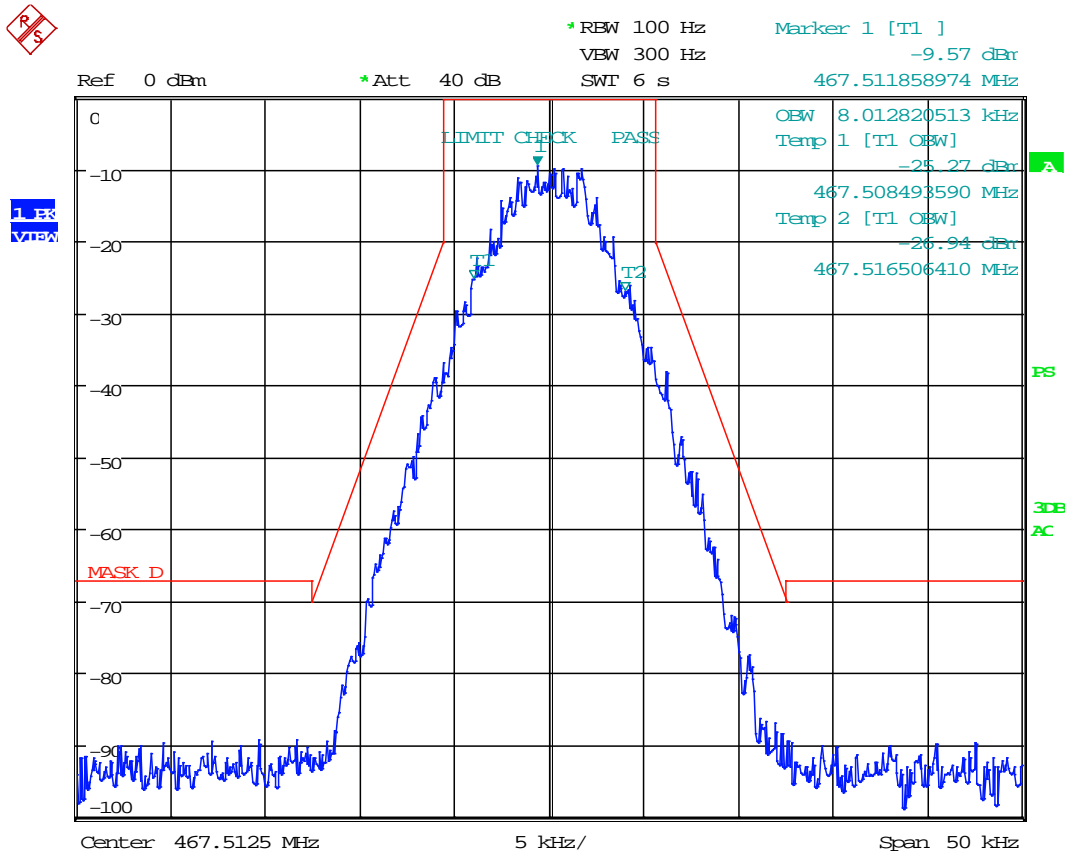

Date: 18.DEC.2017 15:14:52

INPUT-VERSUS-OUTPUT SIGNAL COMPARISON §4.4

Test Data: 454.500 MHz – P25 Phase 1 C4FM Output Signal

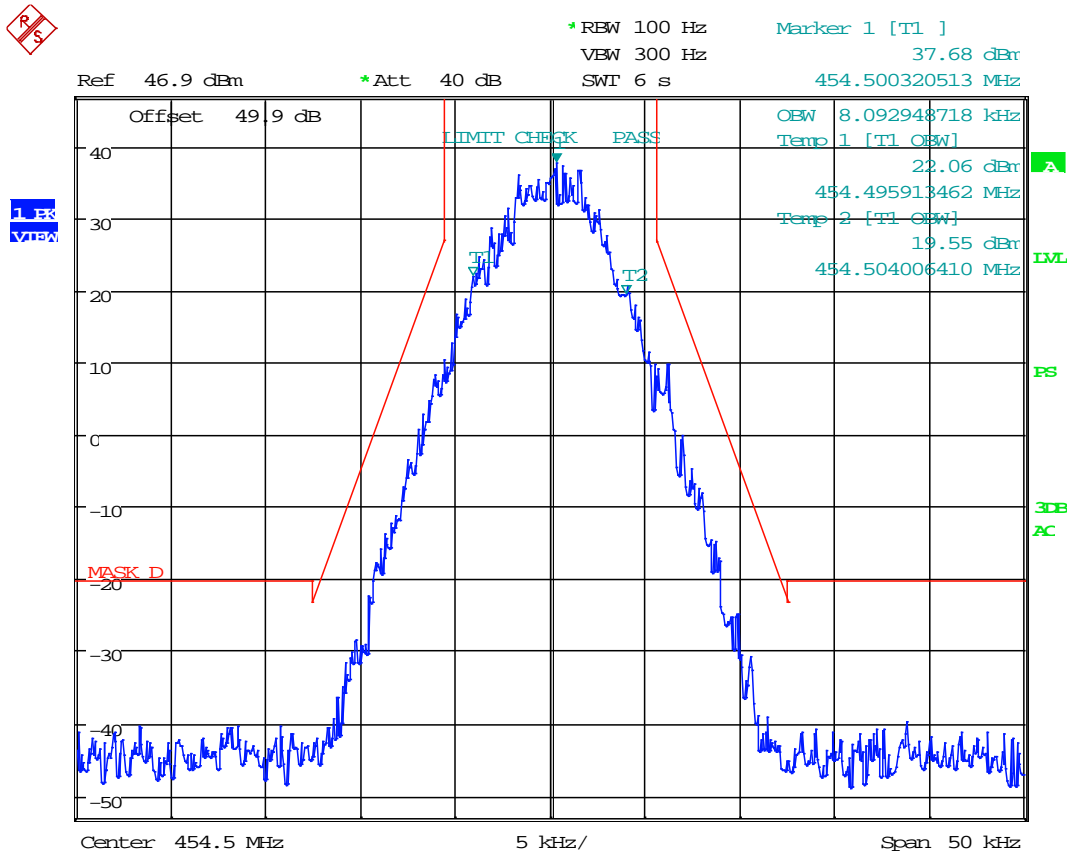

Date: 18.DEC.2017 16:21:45

INPUT-VERSUS-OUTPUT SIGNAL COMPARISON §4.4

Test Data: 454.500 MHz – P25 Phase 2 H-CPM Test Signal

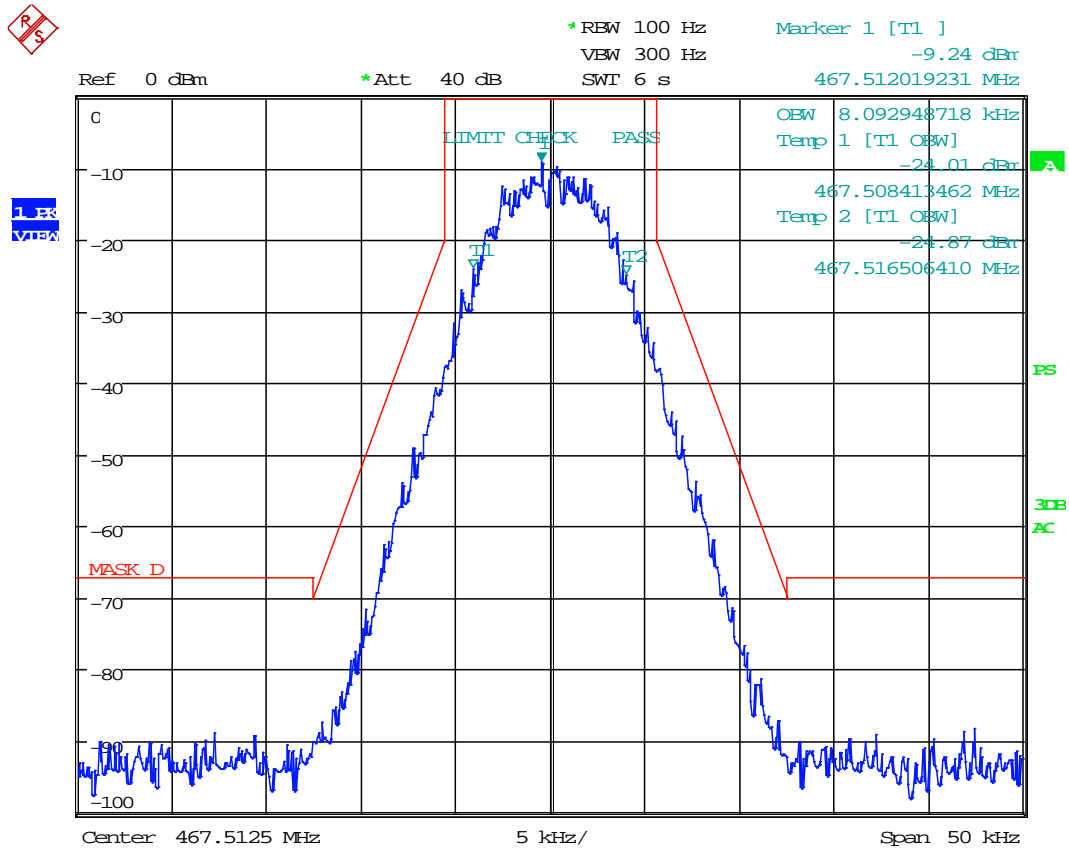

Date: 18.DEC.2017 15:19:41

INPUT-VERSUS-OUTPUT SIGNAL COMPARISON §4.4

Test Data: 454.500 MHz – P25 Phase 2 H-CPM Output Signal

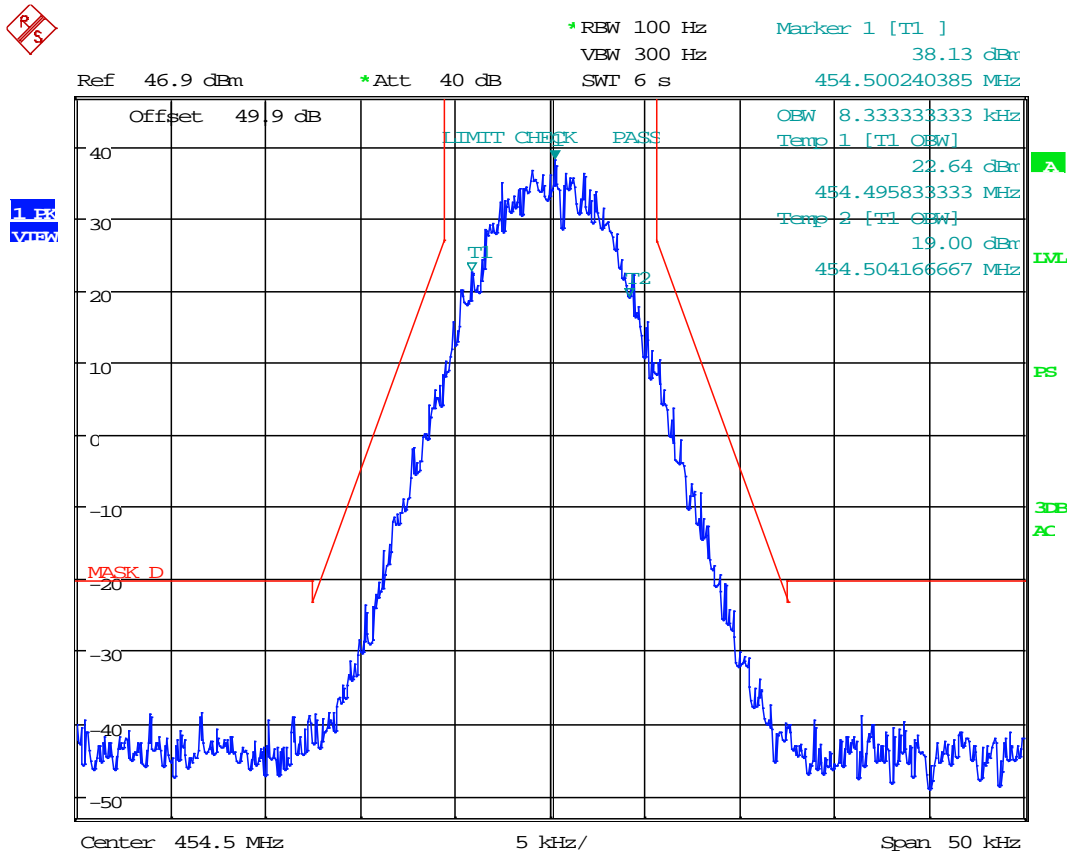

Date: 18.DEC.2017 16:17:22

INPUT-VERSUS-OUTPUT SIGNAL COMPARISON §4.4, 459.975 MHz

Test Data: 459.975 MHz – 6.25 kHz Test Signal

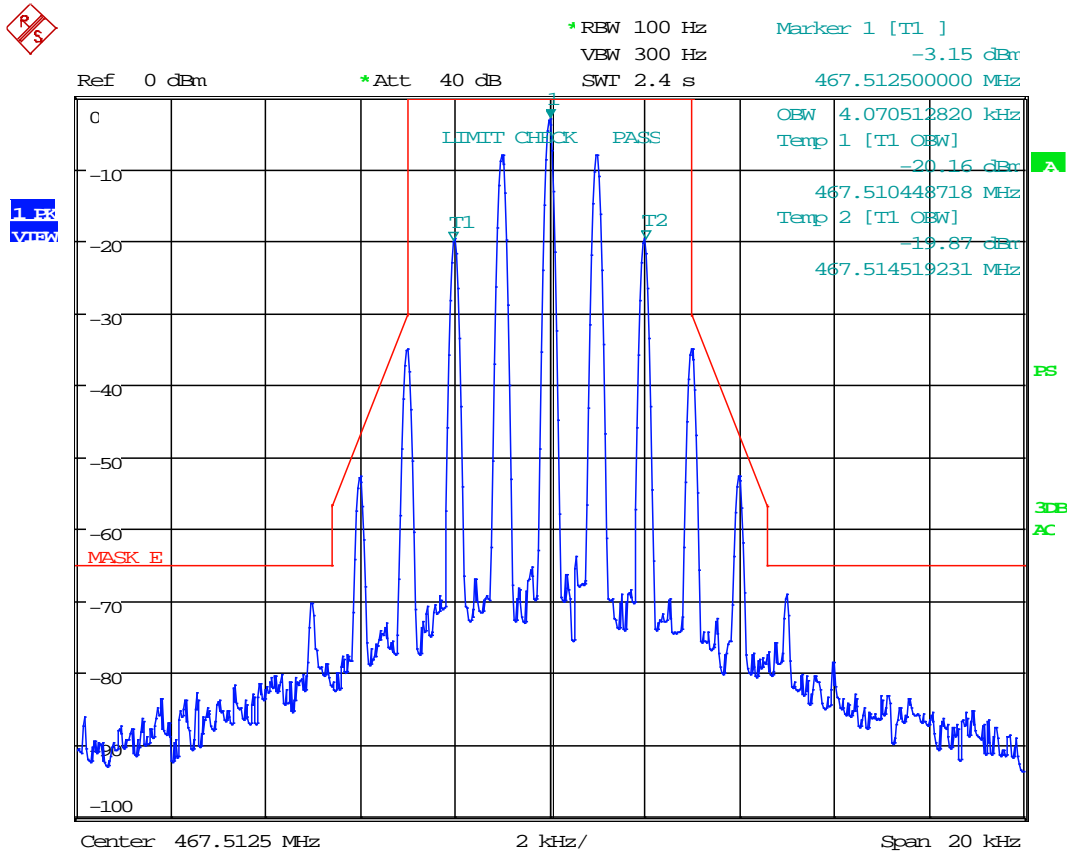

Date: 18.DEC.2017 15:10:34

INPUT-VERSUS-OUTPUT SIGNAL COMPARISON §4.4

Test Data: 459.975 MHz – 6.25 kHz Output Signal

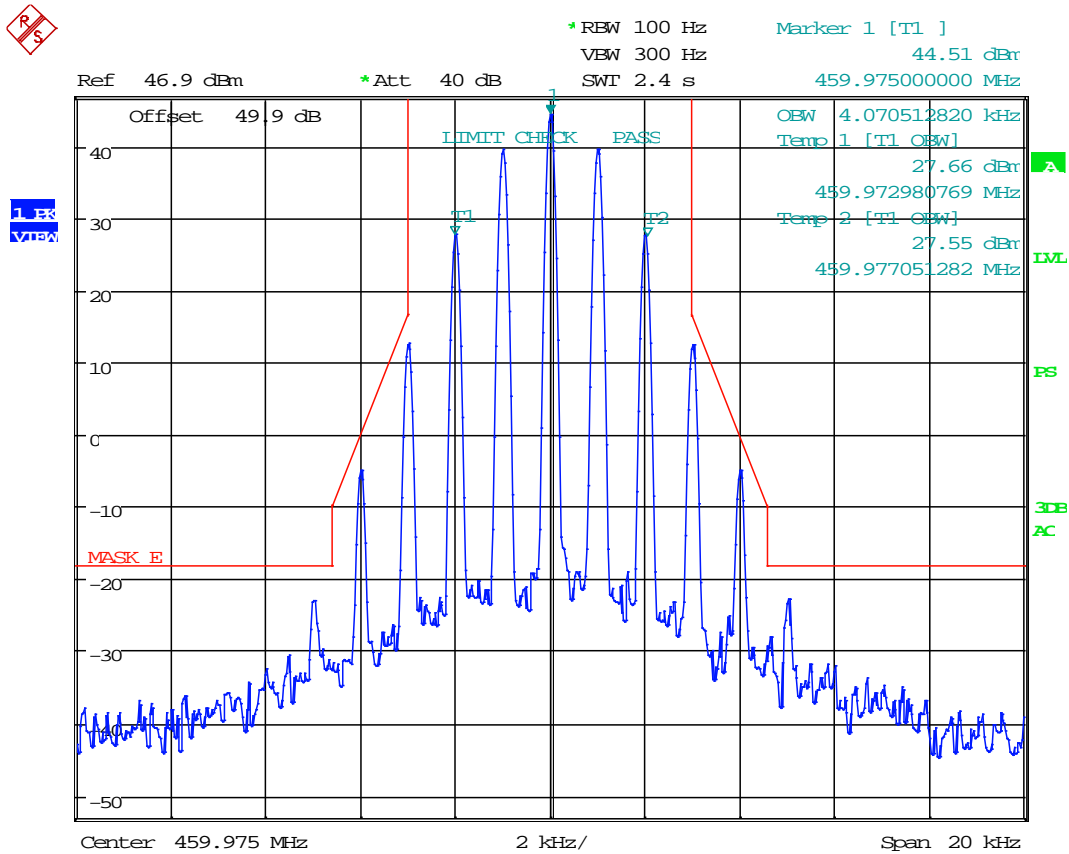

Date: 18.DEC.2017 15:49:51

INPUT-VERSUS-OUTPUT SIGNAL COMPARISON §4.4

Test Data: 459.975 MHz – 12.5 kHz Test Signal

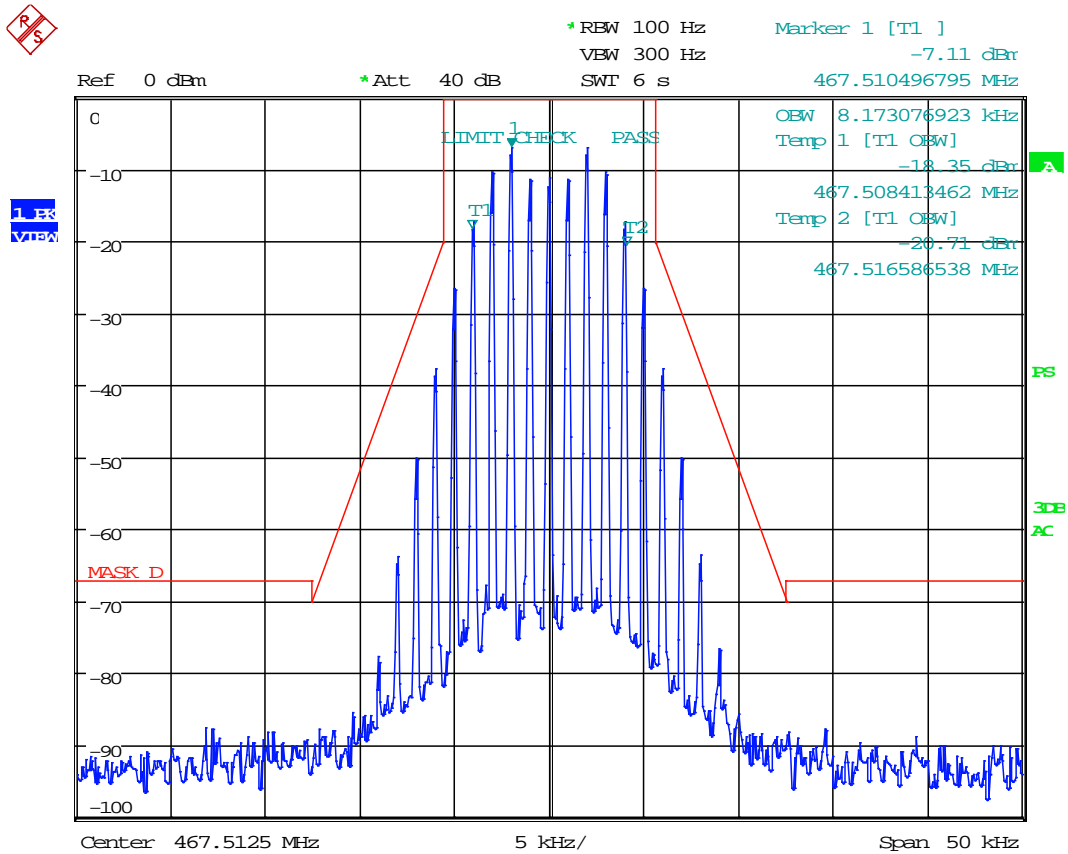

Date: 18.DEC.2017 15:12:10

INPUT-VERSUS-OUTPUT SIGNAL COMPARISON §4.4

Test Data: 459.975 MHz – 12.5 kHz Output Signal

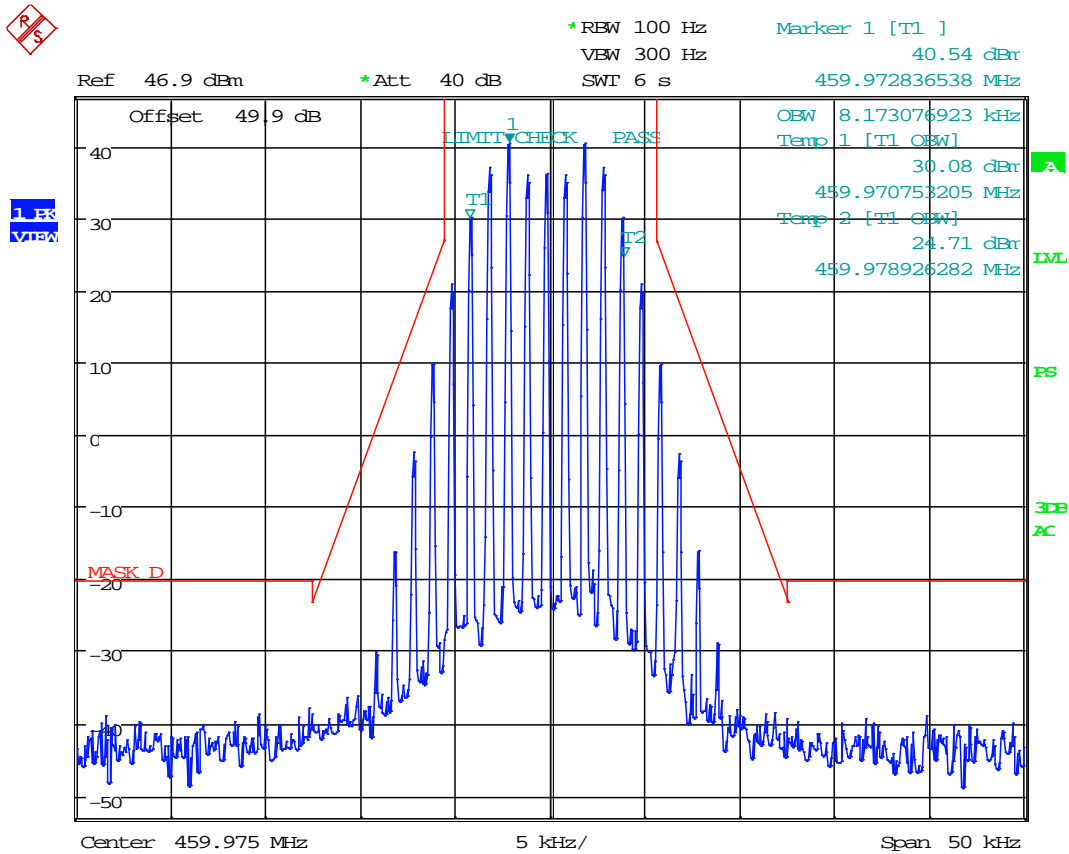

Date: 18.DEC.2017 15:32:03

INPUT-VERSUS-OUTPUT SIGNAL COMPARISON §4.4

Test Data: 459.975 MHz – 25 kHz Test Signal

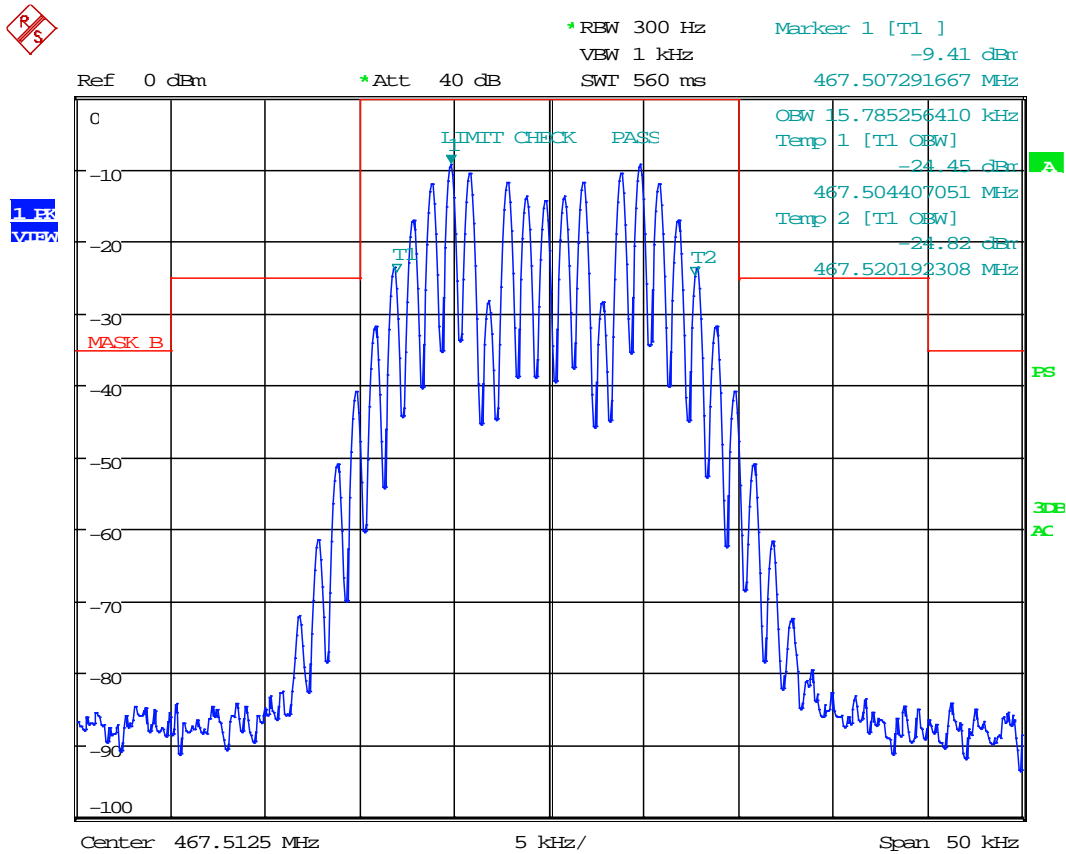

Date: 18.DEC.2017 15:03:40

INPUT-VERSUS-OUTPUT SIGNAL COMPARISON §4.4

Test Data: 459.975 MHz – 25 kHz Output Signal

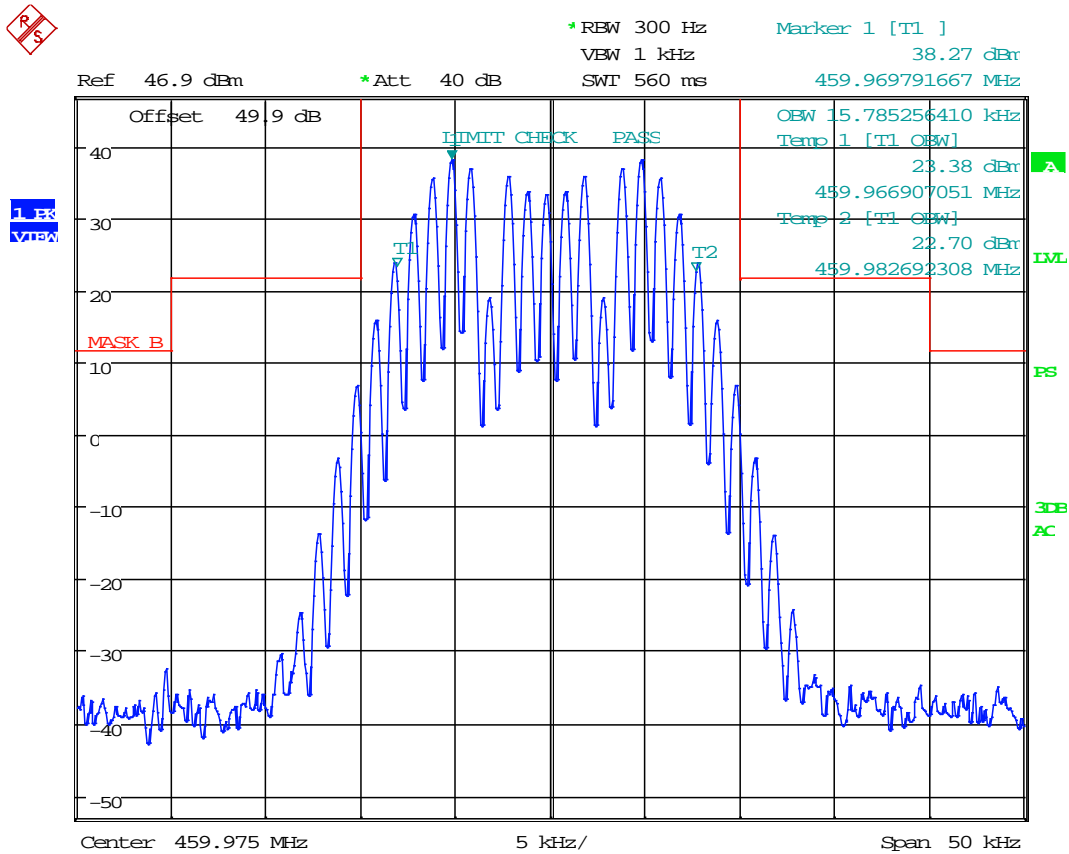

Date: 18.DEC.2017 15:40:21

INPUT-VERSUS-OUTPUT SIGNAL COMPARISON §4.4

Test Data: 459.975 MHz – P25 Phase 1 C4FM Test Signal

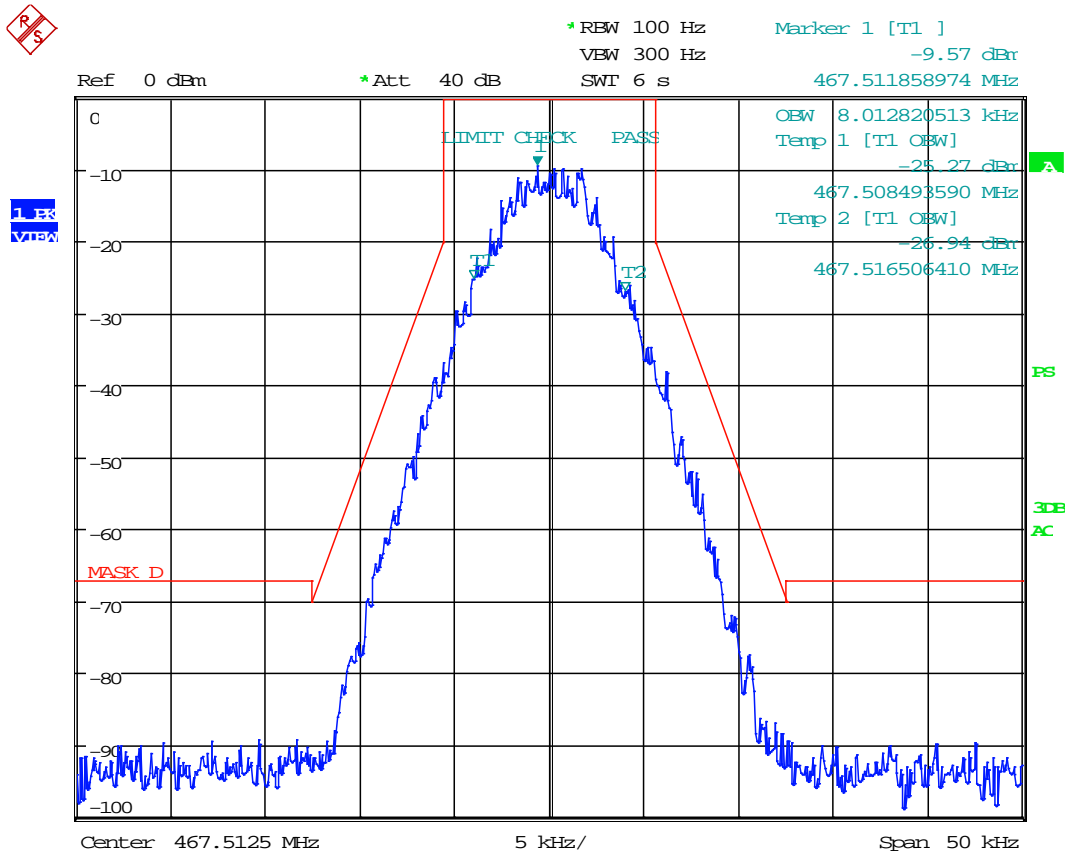

Date: 18.DEC.2017 15:14:52

INPUT-VERSUS-OUTPUT SIGNAL COMPARISON §4.4

Test Data: 459.975 MHz – P25 Phase 1 C4FM Output Signal

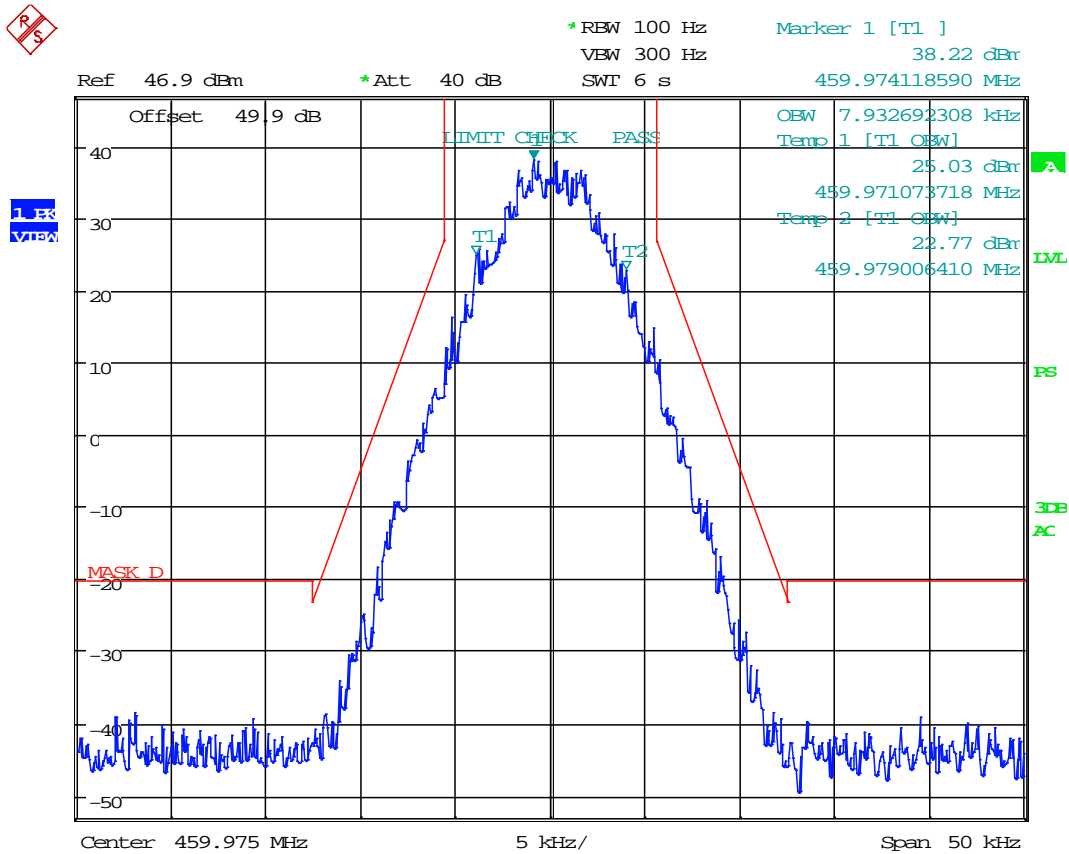

Date: 18.DEC.2017 16:13:21

INPUT-VERSUS-OUTPUT SIGNAL COMPARISON §4.4

Test Data: 459.975 MHz – P25 Phase 2 H-CPM Test Signal

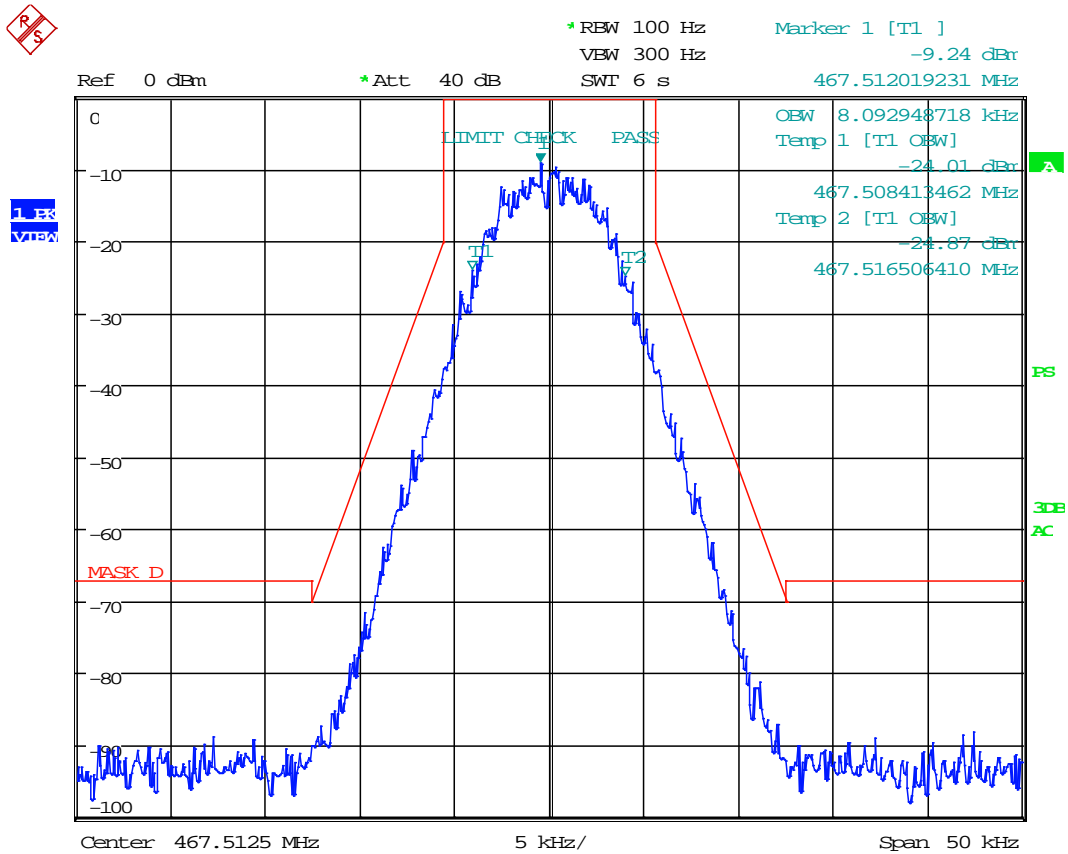

Date: 18.DEC.2017 15:19:41

INPUT-VERSUS-OUTPUT SIGNAL COMPARISON §4.4

Test Data: 459.975 MHz – P25 Phase 2 H-CPM Output Signal

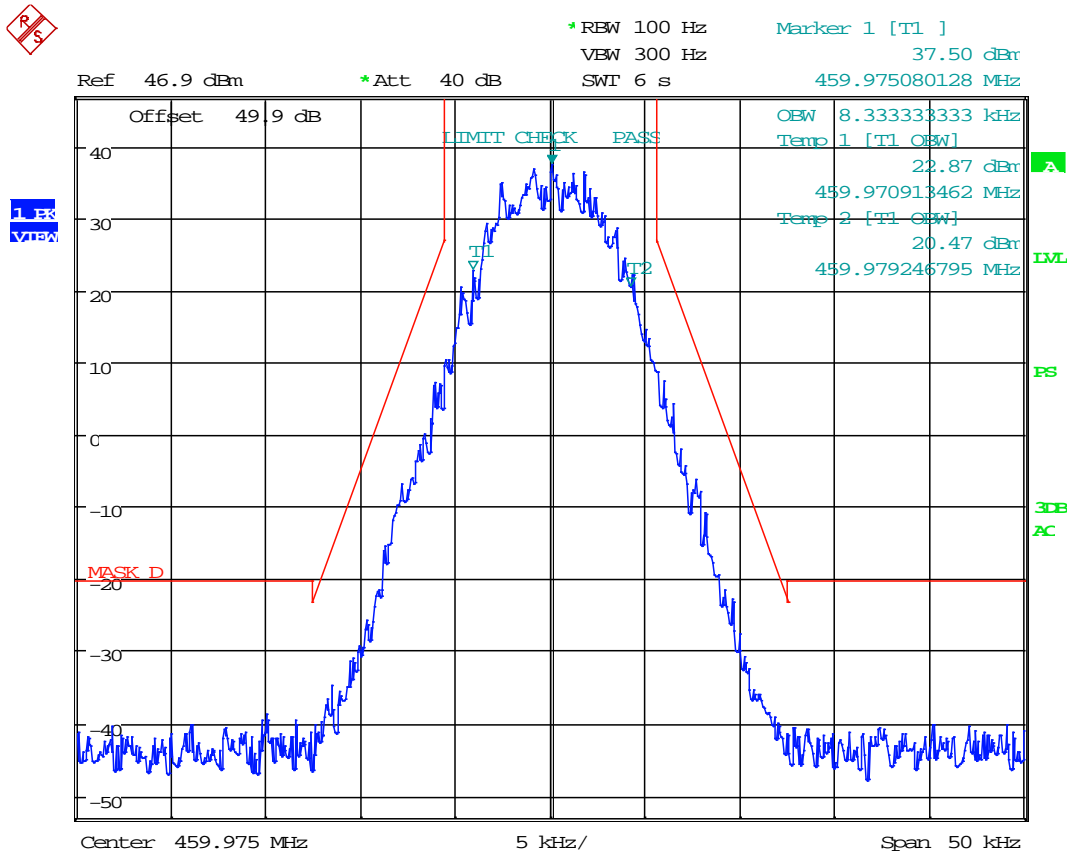

Date: 18.DEC.2017 16:12:20

NOISE FIGURE §4.6

Rule Part No.: KDB 935210-D05 v01r02 §4.6

Requirements: 9 dB

Procedure: KDB935210 Measurement Guidance for Industrial Boosters
§ 4.6 Noise Figure Measurements

1MA178_2e R&S Application Note the Y Factor Technique Noise Figure
§ 2 Background Theory and Equations
§ 3 Detailed Measurement Steps

Setup Diagram:

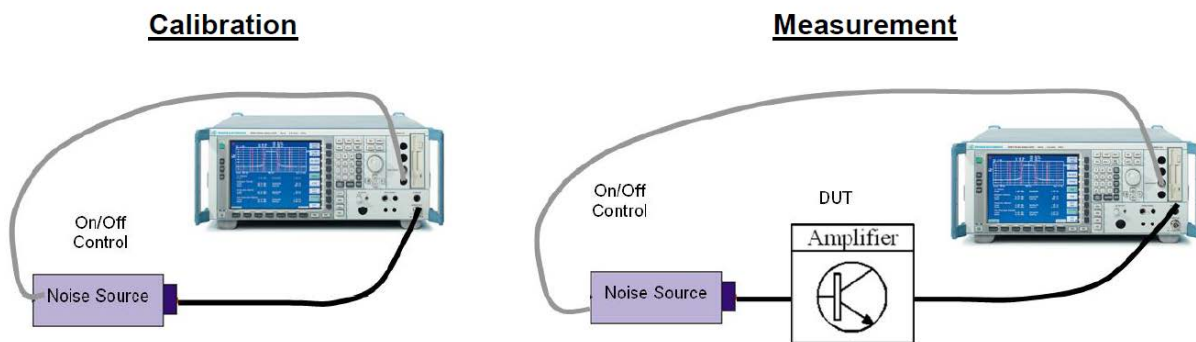

Result: Not Applicable per KDB Inquiry 925403

OUT OF BAND / OUT OF BLOCK EMISSIONS §4.7

Rule Part No.: FCC Pt. 90.210
KDB 935210-D05 v01r02 §4.7.2

Requirements: -15.45 dBm (see Note on Pg. 7)

Procedure: KDB935210 Measurement Guidance for Industrial Boosters
§ 4.7.1 General
§ 4.7.2 Out of Band/ Out of block emissions conducted measurements

Result: Not Applicable per KDB Inquiry 885618



ANTENNA CONDUCTED EMISSIONS §4.7

Rule Part No.: FCC Pt. 90.210
KDB 935210-D05 v01r02 §4.7.3

Requirements: -20.26 dBm in any 100 kHz bandwidth (see Note on Pg. 7)

Procedure: KDB935210 Measurement Guidance for Industrial Boosters
§ 4.7.1 General
§ 4.7.3 EUT Spurious emissions conducted measurements

Note: All test frequencies were transmitted while the trace was set to Peak Max Hold, and the most strict limit line was applied to the screen to show compliance while in the required Resolution Bandwidth (limit line set as per the Note found on Pg. 7).

ANTENNA CONDUCTED EMISSIONS §4.7

Test Data: All Test Frequencies (454 – 460 MHz)

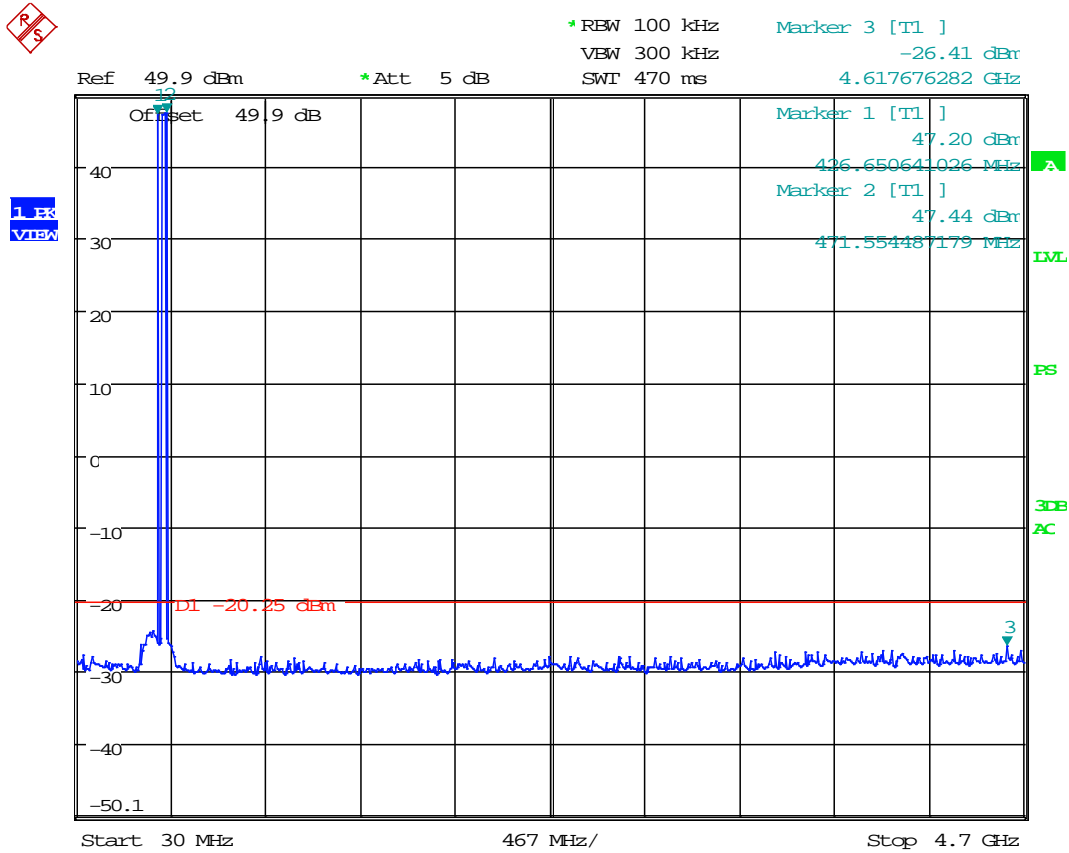

Date: 18.DEC.2017 13:28:36



FREQUENCY STABILITY MEASUREMENTS §4.8

Rule Part No.: FCC 22.355
KDB 935210-D05 v01r02 §4.9

Requirements: 2.5 ppm

Procedure: KDB935210 Measurement Guidance for Industrial Boosters
§ 4.8 Frequency Stability Measurements

FCC Part 22 states "Except as otherwise provided in this part, the carrier frequency of each transmitter in the Public Mobile Services must be maintained within the tolerances given in Table C-1 of this section."

This requirement presumes that the EUT processes an input signal in ways that can influence the output signal frequency/frequencies; however, most signal boosters do not incorporate an oscillator. If the amplifier, booster, or repeater does not alter the input signal in any way, then a frequency stability test may not be required per KDB 935210-D05 v01r02 §4.9.

Result: Not required per KDB 935210-D05 v01r02 §4.9



FIELD STRENGTH OF SPURIOUS RADIATION EMISSIONS §4.9

Rule Part No.: FCC Pt. 90.210
KDB 935210-D05 v01r02 §4.9

Requirements: -20.26 dBm in any 100 kHz bandwidth (see Note on Pg. 7)

Procedure: KDB935210 Measurement Guidance for Industrial Boosters
§ 4.7.1 General
§ 4.9 Spurious emissions radiated measurements

The tabulated data shows the results of the radiated field strength emissions test. The spectrum was scanned from 9 KHz to at least the tenth harmonic of the fundamental. The EUT was oriented in the worst-case polarity, and was scanned in the worst-case emission range as determined in prior testing. Measurements were made at the test site of **TIMCO ENGINEERING, INC. located at 849 NW State Road 45, Newberry, FL 32669.**

NOTE: The highest six (6) emissions per operating band are tabulated in the plots below. Emissions under 20 dB within the applicable limit(s) are not required to be shown.

Test Data: 454.5 MHz Radiated Emission Table

Tuned Frequency					
454.5 MHz					
Emission Frequency (MHz)	Antenna Polarity	Field Strength (dBuV/m)	ERP (dBm)	Limit (dBm)	Margin (dBm)
2272.50	V	42.26	-55.12	-20.25	34.87
4545.00	V	42.20	-55.18	-20.25	34.93
909.00	V	41.92	-55.46	-20.25	35.21
4090.50	H	41.66	-55.72	-20.25	35.47
4545.00	H	40.78	-56.60	-20.25	36.35
1818.00	V	40.32	-57.06	-20.25	36.81



FIELD STRENGTH OF SPURIOUS RADIATION EMISSIONS §4.9

Test Data: 459.975 MHz Radiated Emission Table

Tuned Frequency					
459.975 MHz					
Emission Frequency (MHz)	Antenna Polarity	Field Strength (dBuV/m)	ERP (dBm)	Limit (dBm)	Margin (dBm)
2299.88	H	45.05	-52.33	-20.25	32.08
1839.90	V	44.73	-52.65	-20.25	32.40
2299.88	V	44.56	-52.82	-20.25	32.57
919.95	H	42.41	-54.97	-20.25	34.72
4139.77	H	41.42	-55.96	-20.25	35.71
3219.82	H	40.87	-56.51	-20.25	36.26



EQUIPMENT LIST

Device	Manufacturer	Model	Serial Number	Cal/Char Date	Due Date
Coaxial Cable - BMBM-0065-01 Black DC-2G	Belden		BMBM-0065-01	07/18/16	07/18/18
Antenna: Passive Loop	EMCO	6512	9706-1211	07/26/17	07/26/19
Antenna: Biconical 1096	Eaton	94455-1	1096	08/01/17	08/01/19
Antenna: Log-Periodic 1243	Eaton	96005	1243	02/09/16	03/09/18
Coaxial Cable - Chamber 3 cable set (backup)	Micro-Coax	Chamber 3 cable set (backup)	KMKM-0244-02 ; KMKM-0670-01; KFKF-0197-00	N/A	N/A
CHAMBER	Panashield	3M	N/A	04/25/16	03/31/18
HP Signal Generator	HP	8648C	3847A04696	04/05/2017	04/05/2019
Antenna: Double-Ridged Horn/ETS Horn 2	ETS-Lindgren	3117	00041534	03/01/17	03/01/19
EMI Test Receiver R & S ESIB 40 Screen Room	Rohde & Schwarz	ESIB 40	100274	08/16/16	08/16/18
Software: Field Strength Program	Timco	N/A	Version 4.10.7.0	N/A	N/A
EMI Test Receiver R & S ESU 40 Chamber	Rohde & Schwarz	ESU 40	100320	04/01/16	04/01/18
Coaxial Cable - BMBM-0130-00 Black	Alpha Wire		BMBM-0130-00	05/24/16	05/24/18
Coaxial Cable - BMBM-0155-01 Black	BELDEN		BMBM-0155-01	06/01/16	06/01/18
Coaxial Cable - BMBM-0065-00 Black	Belden		BMBM-0065-00	06/08/16	06/08/18
Coaxial Cable - BMBM-0155-00 Black	MIYAZAKI		BMBM-0155-00	05/24/16	05/24/18
Splitter 1-1000MHz	Mini-Circuits	ZFSC-4-1-BNC+	U115700825	N/A	N/A
Signal Generator R & S SMU 200A	Rohde & Schwarz	SMU200A	103195	02/29/16	02/28/18
Non Radiating 50 OHM Load	Sierra Elec	160B-600X	1038	09/13/16	09/13/18
Attenuator N 30dB 500W DC-2.5G	Bird	8325	1761	05/18/15	05/18/18
Attenuator N 20dB 2W DC-13G	Narda	757C	30201	05/24/17	05/24/19
Attenuator N 20dB 2W DC-13G	Narda	777C	36124	05/24/17	05/23/19
Bore-sight Antenna Positioning Tower	Sunol Sciences	TLT2	N/A	N/A	N/A

*EMI RECEIVER SOFTWARE VERSION

The receiver firmware used was version 4.43 Service Pack 3

STATEMENT OF MEASUREMENT UNCERTAINTY

The data and results referenced in this document are true and accurate. The measurement uncertainty was calculated for all measurements listed in this test report according To CISPR 16-4 or ENTR 100-028 Specification for radio disturbance and immunity measuring apparatus and methods – Part 4: “Uncertainty in EMC Measurements” and is documented in the Timco Engineering, Inc. quality system according to DIN EN ISO/IEC 17025. Furthermore, component and process variability of devices similar to that tested may result in additional deviation. The manufacturer has the sole responsibility of continued compliance of the device.

Hereafter the best measurement capability for Timco Engineering, Inc. is reported:

Test Items	Measurement Uncertainty	Notes
RF Frequency Accuracy	± 49.5 Hz	(1)
RF Conducted Power	±0.93dB	(1)
Conducted spurious emission of transmitter valid up to 40GHz	±1.86dB	
Occupied Bandwidth	±2.65%	
Audio Frequency Response	±1.86dB	
Modulation limiting	±1.88%	
Radiated RF Power	±1.4dB	
Maximum frequency deviation: Within 300 Hz and 6kHz of audio freq.	±1.88%	
Within 6kHz and 25kHz of audio Freq.	±2.04%	
Rad Emissions Sub Meth up to 26.5GHz	±2.14dB	
Rad Emissions Sub Meth up to 18-40 GHz	±2.04%	
Adjacent channel power	±1.47dB	(1)
Transient Frequency Response	±1.88%	
Temperature	±1.0°C	(1)
Humidity	±5.0%	

This uncertainty represents an expanded uncertainty expressed at approximately the 95% confidence level using a coverage factor of k=1.96.

END OF REPORT