



FCC CFR 47 Part 90.219 Test Report

APPLICANT	CRESCEND TECHNOLOGIES, LLC
ADDRESS	140 E. State Parkway SCHAUMBURG IL 60173 USA
FCC ID	CWWDSDTJK50
MODEL NUMBER	DSDTJK50-01T
PRODUCT DESCRIPTION	700/800 MHZ MOBILE PA
DATE SAMPLE RECEIVED	08/23/2019
FINAL TEST DATE	08/28/2019
TESTED BY	Franklin Rose
APPROVED BY	Tim Royer
TEST RESULTS	<input checked="" type="checkbox"/> PASS <input type="checkbox"/> FAIL

Report Number	Report Version	Description	Issue Date
2233AUT19TestReport_	Rev1	Initial Issue	08/28/2019

THE ATTACHED REPORT SHALL NOT BE REPRODUCED EXCEPT IN FULL WITHOUT THE WRITTEN APPROVAL OF TIMCO ENGINEERING, INC.

TABLE OF CONTENTS

GENERAL REMARKS	2
GENERAL INFORMATION	3
SUMMARY OF RESULTS	4
EMISSION DESIGNATION	5
TEST FREQUENCIES	6
INPUT SIGNALS	7
4K00F3E (NARROWBAND ANALOG FM VOICE)	8
8K10F1E/F1D (P25 PHASE I C4FM VOICE, DATA).....	9
8K10F1W (P25 PHASE II H-CPM VOICE & DATA).....	10
11K3F3E (NARROWBAND ANALOG FM VOICE)	11
16K0F3E (WIDEBAND ANALOG FM VOICE)	12
AGC THRESHOLD	13
TEST DATA: AGC MEASUREMENT TABLE	14
TEST DATA: AGC MEASUREMENT PLOT.....	15
OUT OF BAND REJECTION	16
TEST DATA: OUT OF BAND REJECTION, OPERATIONAL BAND	17
TEST DATA: OUT OF BAND REJECTION, EQUIPMENT FUNCTIONAL BAND	18
TEST DATA: OUT OF BAND REJECTION, EQUIPMENT FUNCTIONAL BAND @ MAX POWER	19
INPUT VS OUTPUT COMPARISON	20
772 MHz	26
802 MHz	36
807.5 MHz	46
816.5 MHz	56
852.5 MHz	66
861.5 MHz	76
ADJACENT CHANNEL POWER	86
TEST DATA: N/A.....	86
RF POWER OUTPUT	87
TEST DATA: 700 BAND MEASUREMENT TABLE	88
POWER TO FINAL AMPLIFIER	89
TEST DATA: POWER TO FINAL AMPLIFIER CALCULATION	89
NOISE FIGURE	90
700 BAND NOISE FIGURE	91
INTERMODULATION SPURIOUS EMISSIONS	92
SPURIOUS EMISSIONS AT ANTENNA TERMINALS	93
TEST DATA: CONDUCTED SPURIOUS EMISSIONS BELOW 1 GHZ	94
TEST DATA: CONDUCTED SPURIOUS EMISSIONS ABOVE 1 GHZ.....	95
FREQUENCY STABILITY	96
FIELD STRENGTH OF SPURIOUS EMISSIONS	97
769.2 MHz RADIATED SPURIOUS EMISSIONS.....	99
799.0 MHz RADIATED SPURIOUS EMISSIONS.....	99
815.0 MHz RADIATED SPURIOUS EMISSIONS.....	100
860.0 MHz RADIATED SPURIOUS EMISSIONS.....	100
STATEMENT OF MEASUREMENT UNCERTAINTY	101
EMC EQUIPMENT LIST	102

GENERAL REMARKS

Summary

The device under test does:

- Fulfill the general approval requirements as identified in this test report and was selected by the customer.
- Not fulfill the general approval requirements as identified in this test report

Attestations

This equipment has been tested in accordance with the standards identified in this test report. To the best of my knowledge and belief, these tests were performed using the measurement procedures described in this report.

All instrumentation and accessories used to test products for compliance to the indicated standards are calibrated regularly in accordance with ISO 17025 requirements.

I attest that the necessary measurements were made at:

Timco Engineering Inc.
849 NW State Road 45
Newberry, FL 32669
Designation #: US1070

Tested by:



Name and Title Franklin Rose, Project Manager / EMC Specialist

Date 08/28/2019

Reviewed and Approved by:



Name and Title Tim Royer, Project Manager / EMC Engineer

Date 09/03/2019

GENERAL INFORMATION

EUT Definition: FCC 90.219(a)

Signal booster. A device or system that automatically receives, amplifies, and retransmits signals from wireless stations into and out of building interiors, tunnels, shielded outdoor areas and other locations where these signals would otherwise be too weak for reliable communications. Signal booster systems may contain both Class A and Class B signal boosters as components.

EUT Technical Specifications:

EUT Description	700/800 MHZ MOBILE PA		
EUT Details	Uni-Directional 769-869 MHz FCC Class B Amplifier for Mobile Public Safety Transceivers		
FCC ID	CWW DSDTJK50		
Model Number	DSDTJK50-01T		
Operating Frequency	Band 1: 769 – 775 MHz Band 2: 799 – 805 MHz Band 3: 806 – 824 MHz Band 4: 851 – 869 MHz		
EUT Power Source	<input type="checkbox"/> 110–120Vac, 50– 60Hz	<input checked="" type="checkbox"/> DC Power	<input type="checkbox"/> Battery Operated
Test Item	<input type="checkbox"/> Engineering Prototype	<input checked="" type="checkbox"/> Pre-Production	<input type="checkbox"/> Production
Type of Equipment	<input type="checkbox"/> Fixed	<input checked="" type="checkbox"/> Mobile	<input type="checkbox"/> Portable
Antenna Connector	External, TNC Type		
Test Conditions	The temperature was 26°C Relative humidity of 50%.		
Modification to the EUT	No Modification to EUT.		
Test Exercise	The EUT was operated in accordance with the service manual using software supplied by the manufacturer.		
Applicable Standards	TIA 603-E:2016, ANSI C63.26, FCC CFR 47 Part 2, Part 90, KDB 935210 D05 v01r02, section 4		
Deviation from Standards	<p>The testing methods for Conducted Spurious Emissions were deviated from in the following ways: The signal was swept throughout the entire operational passband of the device. This enabled the laboratory to determine the worst-case in-band frequencies to be used for Radiated Field Strength of Spurious Emissions.</p> <p>The testing methods for Conducted & Radiated Spurious Emissions were deviated from in the following ways: The signal was input at maximum power into the EUT. This was to ascertain the worst-case radiated spurious emission's field strength in normal operation.</p>		
Test Facility	Timco Engineering Inc. at 849 NW State Road 45 Newberry, FL 32669 USA. Designation #: US1070		

SUMMARY OF RESULTS

Applied Rule Part(s)	Test	Result
KDB 935210 s.4, FCC Pt. 90.531(a)	Test Frequencies	For Reporting Only
KDB 935210 s.4.1	Input Signals	For Reporting Only
KDB 935210 s.4.2	AGC Threshold	For Reporting Only
KDB 935210 s.4.3, FCC Pt. 90.219(a), FCC Pt. 90.219(d)(7)	Out-of-Band Rejection	CLASS B DEVICE
KDB 935210 s.4.4, FCC Pt. 2.1049(c), FCC Pt. 90.219(e)(4)(ii), FCC Pt. 90.210(c)	Input vs. Output Signal Comparison	PASS
KDB 935210 s.4.4, FCC Pt. 90.543(a), (c), (e)	Adjacent Channel Power	n/a
KDB 935210 s.4.5, FCC Pt. 90.219(e)(1), FCC Pt. 90.219(e)(4)(iii)	RF Power Output (and Gain)	PASS
FCC Pt. 2.1033(c)(8)	Power Input to the Final Power Amplifier	For Reporting Only
KDB 935210 s.4.6, FCC Pt. 90.219(e)(2)	Noise Figure	PASS
KDB 935210 s.4.7.2 FCC Part 2.1051(a), FCC Pt. 90.219(d)(6)(i), FCC Pt. 90.219(e)(3)	Intermodulation Spurious Emissions	n/a
KDB 935210 s.4.7.3, FCC Part 2.1051(a), FCC Pt. 90.219(e)(3)	Spurious Emissions at Antenna Terminals	PASS
KDB 935210 s.4.8, FCC Part 2.1055(a)(1), FCC Part 2.1055(b), FCC Pt. 90.219(e)(4)(i)	Frequency Stability	n/a
KDB 935210 s.4.9, FCC Part 2.1053(a), FCC Pt. 90.219(e)(3)	Field Strength of Spurious Emissions	PASS

EMISSION DESIGNATION

Rule Part No.: FCC Part 2.202(g)

Note: All signals used here are representative of the type of signals which will be passed through this EUT, as outlined in KDB 935210 s.4.1.

Analog Signals

Emission Designator	Description	Modulation Type	M (modulation Freq., kHz)	R (rate, baud)	D (deviation, kHz)	K (numeric constant)	S (symbols)	Bandwidth Calculation	Necessary Bandwidth
4K00F3E	Narrowband Analog FM Voice	FM	1.0	-	1.0	1.0	-	Bn = 2M + 2DK	4.00
11K2F3E	Narrowband Analog FM Voice	FM	3.0	-	2.5	1.0	-		11.00
16K0F3E	Wideband Analog FM Voice	FM	3.0	-	5.0	1.0	-		16.00

Digital Signals

Emission Designator	Description	Modulation Type	M (modulation Freq., kHz)	R (rate, baud)	D (deviation, kHz)	K (numeric constant)	S (symbols)	Bandwidth Calculation	Bn (necessary bandwidth, kHz)
4K00F1E	Narrow NXDN Voice	4FSK	-	4800	1.55	0.516	4	Bn = (R/log ₂ S) + 2DK	4.00
4K00F1D	Narrow NXDN Data	4FSK	-	4800	1.55	0.516	4		4.00
4K00F1W	Narrow NXDN Voice/Data	4FSK	-	4800	1.55	0.516	4		4.00
8K30F1E	Wide NXDN Voice	4FSK	-	4800	3	0.984	4		8.30
8K30F1D	Wide NXDN Data	4FSK	-	4800	3	0.984	4		8.30
8K30F1W	Wide NXDN Voice & Data	4FSK	-	4800	3	0.984	4		8.30
4K00F2D	Narrow NXDN CW ID	4FSK	0.8	4800	1.2	1.0	4	Bn = 2M + 2DK	4.00
8K30F2D	Wide NXDN CW ID	4FSK	1.15	4800	3	1	4		8.30
7K60FXE	DMR Voice	4FSK	-	9600	1.8	0.778	4	Bn = (R/log ₂ S) + 2DK	7.60
7K60FXD	DMR Data	4FSK	-	9600	1.8	0.778	4		7.60
8K10F1E	P25 Phase I C4FM Voice	4FSK	-	9600	1.8	0.916	4	Bn = (R/log ₂ S) + 2DK	8.10
8K10F1D	P25 Phase I C4FM Data	4FSK	-	9600	1.8	0.916	4		8.10
8K10F1W	P25 Phase II H-CPM Voice/Data	4FSK	-	9600	1.8	0.916	4		8.10

TEST FREQUENCIES

Rule Part No.: KDB 935210 s.4

All tests specified in KDB 935210 D05, Section 4 are intended for each band/block of operation. The bands/blocks of operation of this EUT are as follows:

EUT Operational Band(s): KDB 935210 D02, Appendix D, Table D.3

Table D.3 – Various Part 90 PLMRS band allocations, rule parts/sections, and service types for Section 90.219 purposes (for info only – see rules for details, also KDB Publication 634817 [R14])

F _L (MHz)	–	F _L (MHz)	Rule(s)	Misc. Notes
758	–	768	90-R, Public Safety (PS) Broadband (FirstNet)	B9B (LTE)
768	–	769	PS Guardband	
769	–	775	PS Narrowband	
788	–	798	90-R, Public Safety (PS) Broadband (FirstNet)	B9B (LTE)
798	–	799	PS Guardband	
799	–	805	PS Narrowband	
806	–	809	90 NPSPAC (PS) [90.617(a)(1)]	B9B/B9A
809	–	815	90 Interleaved PS; B/ILT; SMR [90.614(a); 90.613 ch. nos. 1-470] ^a	B9B/B9A
815	–	816	90 Expansion B/ILT; SMR [90.614(a); 90.613 ch. nos. 470-550] ^a	B9B/B9A
816	–	817	90 Guardband	B9B/B9A
817	–	824	CMRS 90 ESMR [90.614(b); 90.613 ch. nos. 551-830]	B2I 90-S
851	–	854	90 NPSPAC (PS) [90.617(a)(1)]	B9B/B9A
854	–	860	90 Interleaved PS; B/ILT; SMR [90.614(a); 90.613 ch. nos. 1-470] ^a	B9B/B9A
860	–	861	90 Expansion B/ILT; SMR [90.614(a); 90.613 ch. nos. 470-550] ^a	B9B/B9A
861	–	862	90 Guardband	B9B/B9A
862	–	869	CMRS 90 ESMR [90.614(b); 90.613 ch. nos. 551-830]	B2I 90-S

Frequencies for Testing: FCC Pt. 90.531(a)

This section sets forth the band plan for the 758-775 MHz and 788-805 MHz public safety bands.

(a) *Base and mobile use.* The 763-775 MHz band may be used for base, mobile or fixed (repeater) transmissions. The 793-805 MHz band may be used only for mobile or fixed (control) transmissions.

The EUT will utilize the bands:

700 Band			
Operation	Band	Test Frequency(s)	Notes
PLMRS/PSRS	769 – 775 MHz	769.4, 772 MHz	
PLMRS/PSRS	799 – 805 MHz	799, 802 MHz	

800 Band			
Operation	Band	Test Frequency(s)	Notes
PLMRS/PSRS	806 – 824 MHz	807.5, 815, 816.5 MHz	
PLMRS/PSRS	851 – 869 MHz	852.5, 860, 861.5 MHz	

INPUT SIGNALS

Rule Part No.: KDB 935210 s.4.1

The procedures in this clause are specific to EUTs intended for operating in the Private Land Mobile Radio Services (PLMRS) and Public Safety Radio Services (PSRS)⁵, which are governed under the provisions and requirements of the Part 90 rules (i.e., Section 90.219 applies).

Table 1 depicts signal types associated with PLMRS operations, which are to be considered as test signals to be used in performing compliance testing on PLMRS amplifiers, repeaters, and industrial boosters. Not all of the procedures in this clause will require using each of the signals listed in Table 1, because for many EUTs a CW tone can adequately model the narrowband signals typically encountered within these services. For EUTs supporting digitally modulated signals, the intended operating signal types should be tested (e.g., P25 Phase 1, P25 Phase 2, TETRA, etc.), especially for PSRS devices. Devices intended for use in 700 MHz Public Safety Broadband spectrum shall be tested using a representative band-limited AWGN signal (99 % OBW of 4.1 MHz) or the applicable signal type (e.g., LTE).

Table 1—Test signals for PLMRS devices

Emission Designator	Modulation	Occupied Bandwidth	Channel Bandwidth	Audio Frequency
16K0F3E	FM	16 kHz	25 kHz	1 kHz
11K3F3E	FM	11.3 kHz	12.5 kHz	1 kHz
4K00F1E	FM	4 kHz	6.25 kHz	1 kHz
N/A	CW	N/A	N/A	N/A

Note: All input signals are broadcast from an amplifier used to bring the input level to the EUT up to the rated levels. The signal was decreased to 0 dBm (CW) from the test amplifier, and modulation was applied. Actual input levels were higher. Please see RF Power Output section for details.

Input Signals

4K00F3E (Narrowband Analog FM Voice)

Substituted for signals:

4K00F1E (Narrow NXDN Voice)

4K00F1D (Narrow NXDN Data)

4K00F1W (Narrow NXDN Voice & Data)

4K00F2D (Narrow NXDN CW ID)

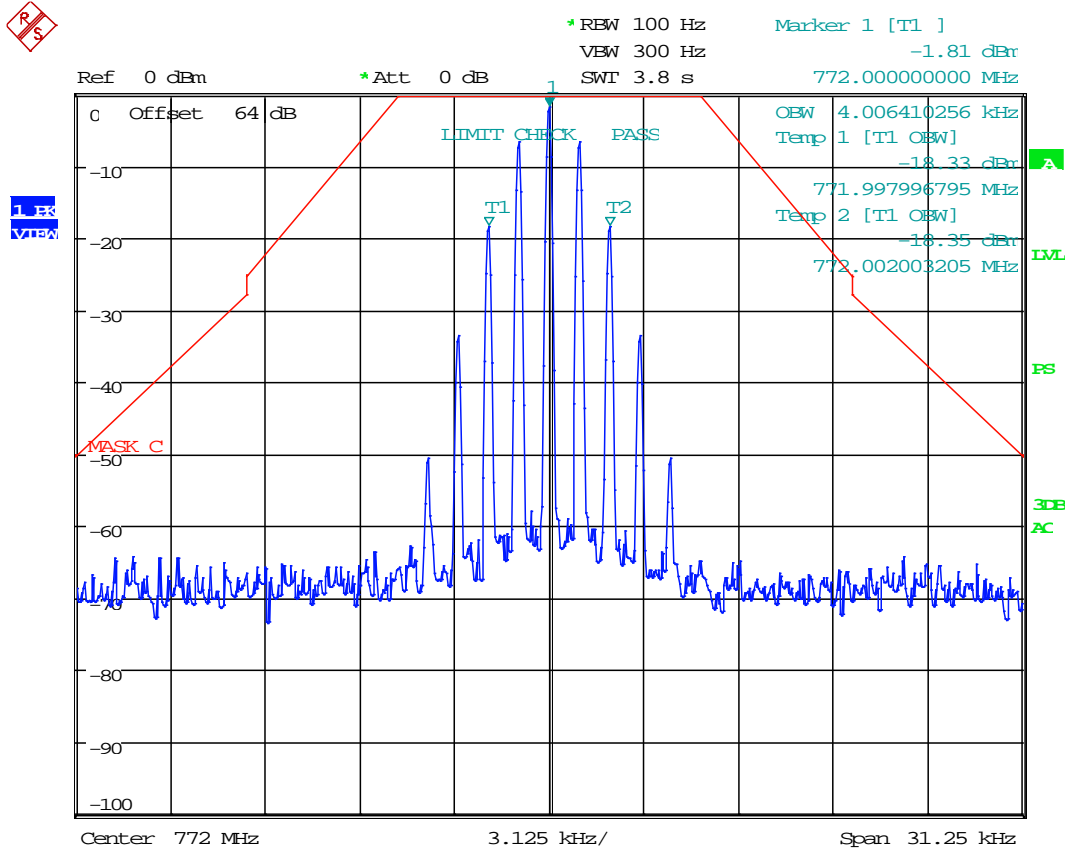

Date: 27.AUG.2019 11:13:08

Occupied Bandwidth: 4.01 kHz

Input Signals

8K10F1E/F1D (P25 Phase I C4FM Voice, Data)

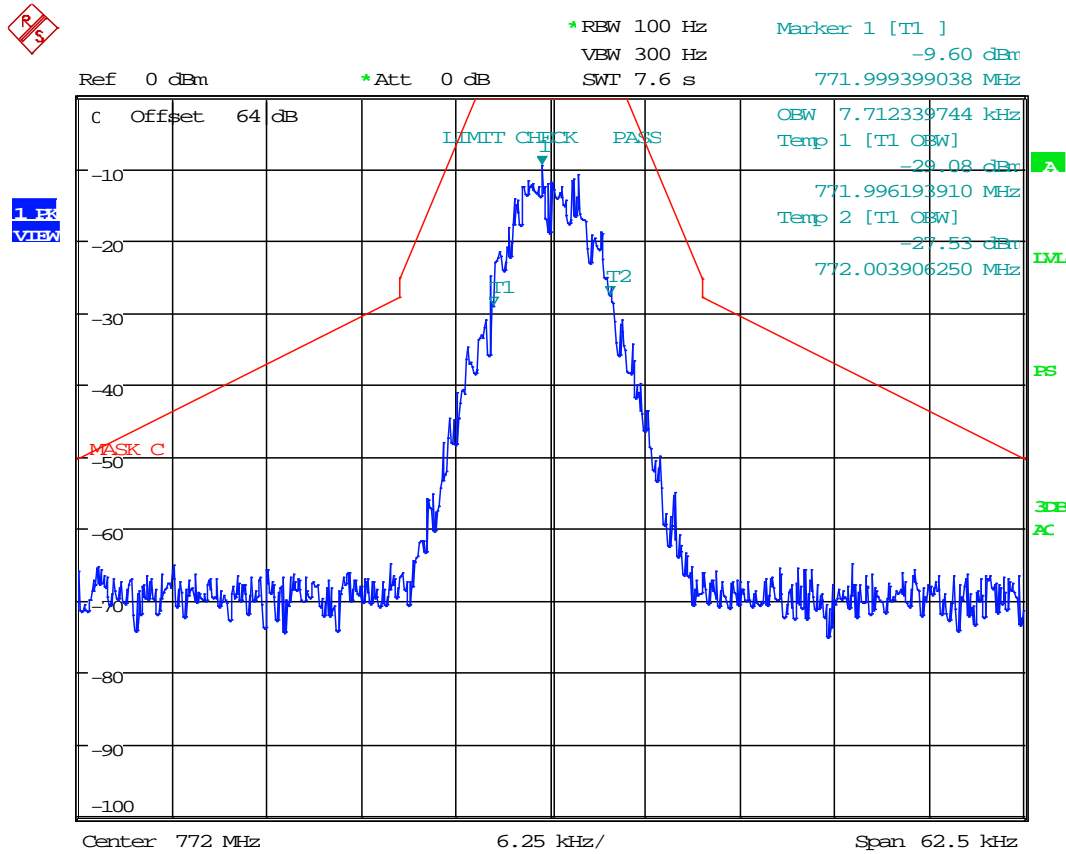

Date: 27.AUG.2019 12:53:31

Occupied Bandwidth: 7.71 kHz

Input Signals

8K10F1W (P25 Phase II H-CPM Voice & Data)

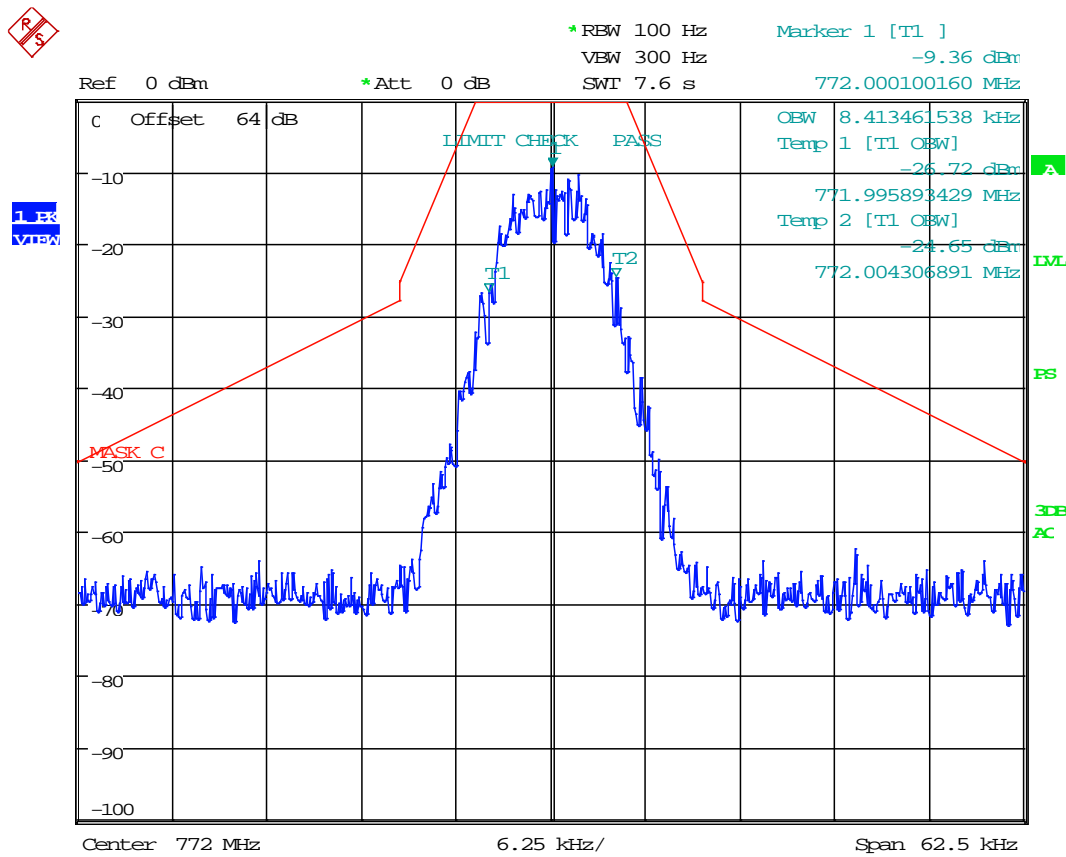

Date: 27.AUG.2019 12:57:20

Occupied Bandwidth: 8.41 kHz

Input Signals

11K3F3E (Narrowband Analog FM Voice)

Substituted for signals:

- 7K60FXE (2-Slot DMR TDMA Voice)
- 7K60FXD (2-Slot DMR TDMA Data)
- 8K30F1E (Wide NXDN Voice)
- 8K30F1D (Wide NXDN Data)
- 8K30F1W (Wide NXDN Voice & Data)
- 8K30F2D (Wide NXDN CW ID)

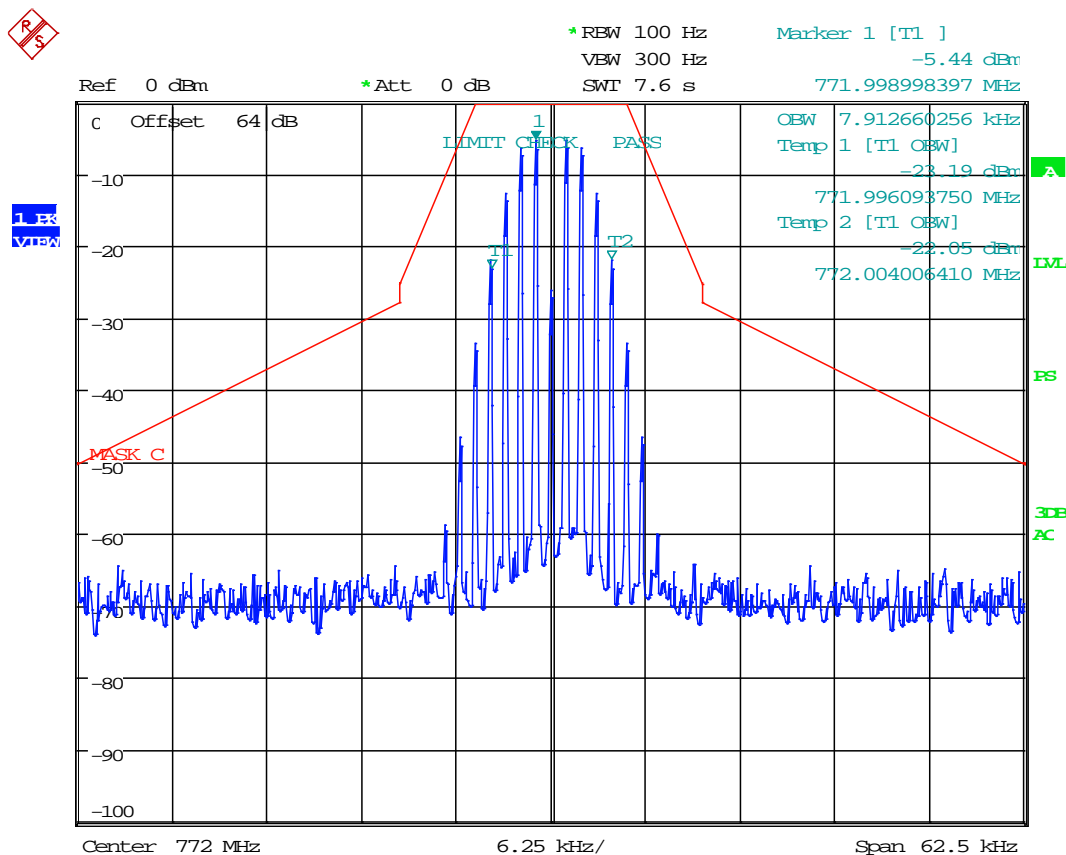

Date: 27.AUG.2019 12:30:43

Occupied Bandwidth: 7.91 kHz

Applicant: CRESCEND TECHNOLOGIES, LLC
 FCC ID: CWW DSDTJK50
 Report: 2233AUT19TestReport_Rev1

Input Signals

16K0F3E (Wideband Analog FM Voice)

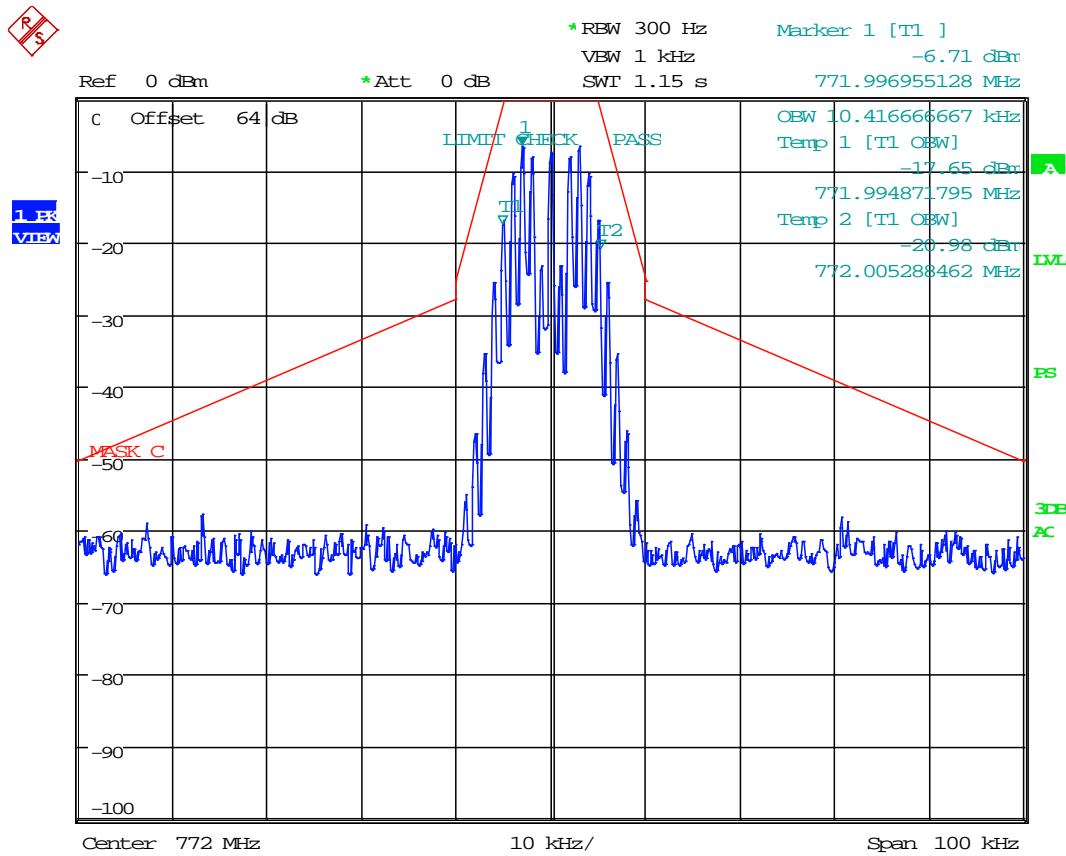

Date: 27.AUG.2019 12:37:31

Occupied Bandwidth: 10.42 kHz

AGC THRESHOLD

Rule Part No.: KDB 935210 s.4.2

Requirements:

Testing at and above the AGC threshold will be required.⁶ The AGC threshold shall be determined by applying the procedure of 3.2, but with the signal generator configured to produce a test signal defined in Table 1, a CW input signal, or a digitally modulated signal, consistent with the discussion about signal types in 4.1.

⁶ See footnote 1 about the terms and concepts AGC, ALC, OLC.

Test Procedure: KDB 935210 s.3.2

The AGC threshold is to be determined as follows.³

In the case of fiber-optic distribution systems, the RF input port of the equipment under test (EUT) refers to the RF input of the supporting equipment RF to optical convertor; see also descriptions and diagrams for typical DAS booster systems in KDB Publication 935210 D02 [R7].

Devices intended to be directly connected to an RF source (donor port) only need to be evaluated for any over-the-air transmit paths.

- a) Connect a signal generator to the input of the EUT.
- b) Connect a spectrum analyzer or power meter to the output of the EUT using appropriate attenuation as necessary.
- c) The signal generator should initially be configured to produce either of the required test signals (i.e., broadband or narrowband).
- d) Set the signal generator frequency to the center frequency of the EUT operating band.
- e) While monitoring the output power of the EUT, measured using the methods of 3.5.3 or 3.5.4, increase the input level until a 1 dB increase in the input signal power no longer causes a 1 dB increase in the output signal power.
- f) Record this level as the AGC threshold level.
- g) Repeat the procedure with the remaining test signal.

³ Consistent with for example TIA-156 [R10], for compliance testing purposes the terms automatic gain control (AGC), automatic level control (ALC), and output level control (OLC) are generally taken to be synonyms, which refer to a means by which gain or output power is electronically adjusted as a function of voltage or some other specified parameter(s).

Test Setup Block Diagram: KDB 935210 s.3.2

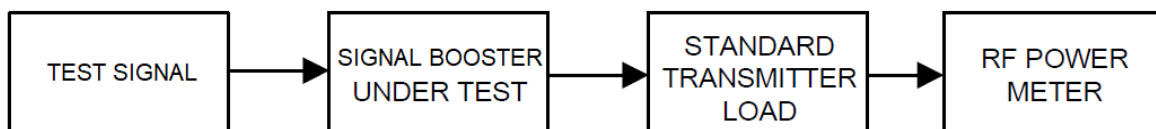

AGC THRESHOLD

Test Data: AGC Measurement Table

INPUT (dBm)	CORRECTED INPUT (dBm)	CORRECTED OUTPUT (dBm)	GAIN (dB)
-30	8.445	7.5	-0.9
-29	9.445	8.36	-1.1
-28	10.445	9.43	-1.0
-27	11.445	10.35	-1.1
-26	12.445	11.31	-1.1
-25	13.445	12.28	-1.2
-24	14.445	13.19	-1.3
-23	15.445	14.21	-1.2
-22	16.445	15.16	-1.3
-21	17.445	16.14	-1.3
-20	18.445	17.13	-1.3
-19	19.445	18.1	-1.3
-18	20.445	19.1	-1.3
-17	21.445	20.1	-1.3
-16	22.445	45.98	23.5
-15	23.445	46.61	23.2
-14	24.445	46.79	22.3
-13	25.445	46.8	21.4
-12	26.445	46.82	20.4
-11	27.445	46.82	19.4
-10	28.445	46.8	18.4
-9	29.445	46.8	17.4
-8	30.445	46.8	16.4
-7	31.445	46.81	15.4
-6	32.445	46.84	14.4
-5	33.445	46.85	13.4
-4	34.445	46.82	12.4
-3	35.445	46.87	11.4
-2	36.445	46.9	10.5

Green: AGC Level

Yellow: AGC Level +3

Orange: AGC Level +14 (Full Input Power)

AGC THRESHOLD

Test Data: AGC Measurement Plot

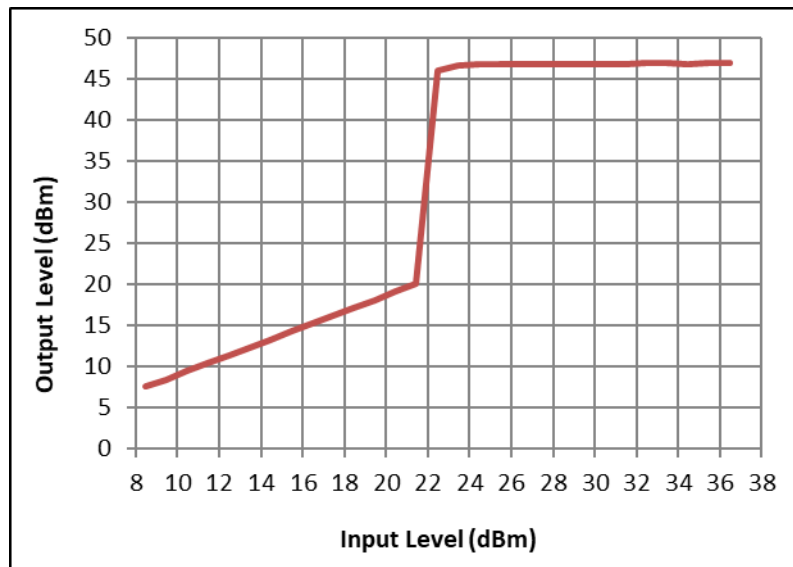

Result:

The EUT passes signals below AGC with ~ 1.0 dB of loss +/- 0.2 dB.

The EUT maintains the output level above AGC at ~ 46.50 +/- 0.5 dB.

The EUT activates AGC at 22.445 dBm*.

***Note:** This behavior was found to be frequency dependent. Please see Out Of Band Rejection section for details.

OUT OF BAND REJECTION

Rule Part No.: KDB 935210 s.4.3, FCC Pt. 90.219(a), FCC Pt. 90.219(d)(7)

(a) *Definitions.* The definitions in this paragraph apply only to the rules in this section.

Class A signal booster. A signal booster designed to retransmit signals on one or more specific channels. A signal booster is deemed to be a Class A signal booster if none of its passbands exceed 75 kHz.

Class B signal booster. A signal booster designed to retransmit any signals within a wide frequency band. A signal booster is deemed to be a Class B signal booster if it has a passband that exceeds 75 kHz.

Requirements:

(7) Signal booster passbands are limited to the service band or bands for which the operator is authorized. In general, signal boosters should utilize the minimum passband that is sufficient to accomplish the purpose. Except for distributed antenna systems (DAS) installed in buildings, the passband of a Class B booster should not encompass both commercial services (such as ESMR and Cellular Radiotelephone) and part 90 Land Mobile and Public Safety Services.

Test Procedure: KDB 935210 s.4.3

Adjust the internal gain control of the EUT to the maximum gain for which equipment certification is sought.

- a) Connect a signal generator to the input of the EUT.
- b) Configure a swept CW signal with the following parameters:
 - 1) Frequency range = $\pm 250\%$ of the manufacturer's specified pass band.
 - 2) The CW amplitude shall be 3 dB below the AGC threshold (see 4.2), and shall not activate the AGC threshold throughout the test.
 - 3) Dwell time = approximately 10 ms.
 - 4) Frequency step = 50 kHz.
- c) Connect a spectrum analyzer to the output of the EUT using appropriate attenuation.
- d) Set the RBW of the spectrum analyzer to between 1 % and 5 % of the manufacturer's rated passband, and $VBW = 3 \times RBW$.
- e) Set the detector to Peak and the trace to Max-Hold.
- f) After the trace is completely filled, place a marker at the peak amplitude, which is designated as f_0 , and with two additional markers (use the marker-delta method) at the 20 dB bandwidth (i.e., at the points where the level has fallen by 20 dB).
- g) Capture the frequency response plot for inclusion in the test report.

Test Setup Block Diagram: KDB 935210 s.4.3

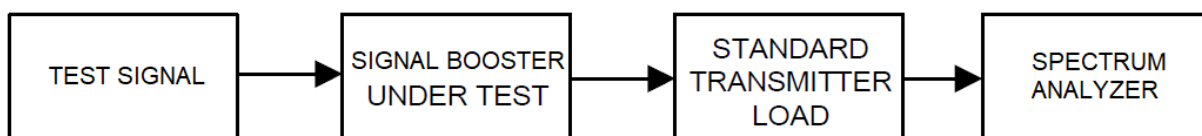

OUT OF BAND REJECTION

Test Data: Out of Band Rejection, Operational Band

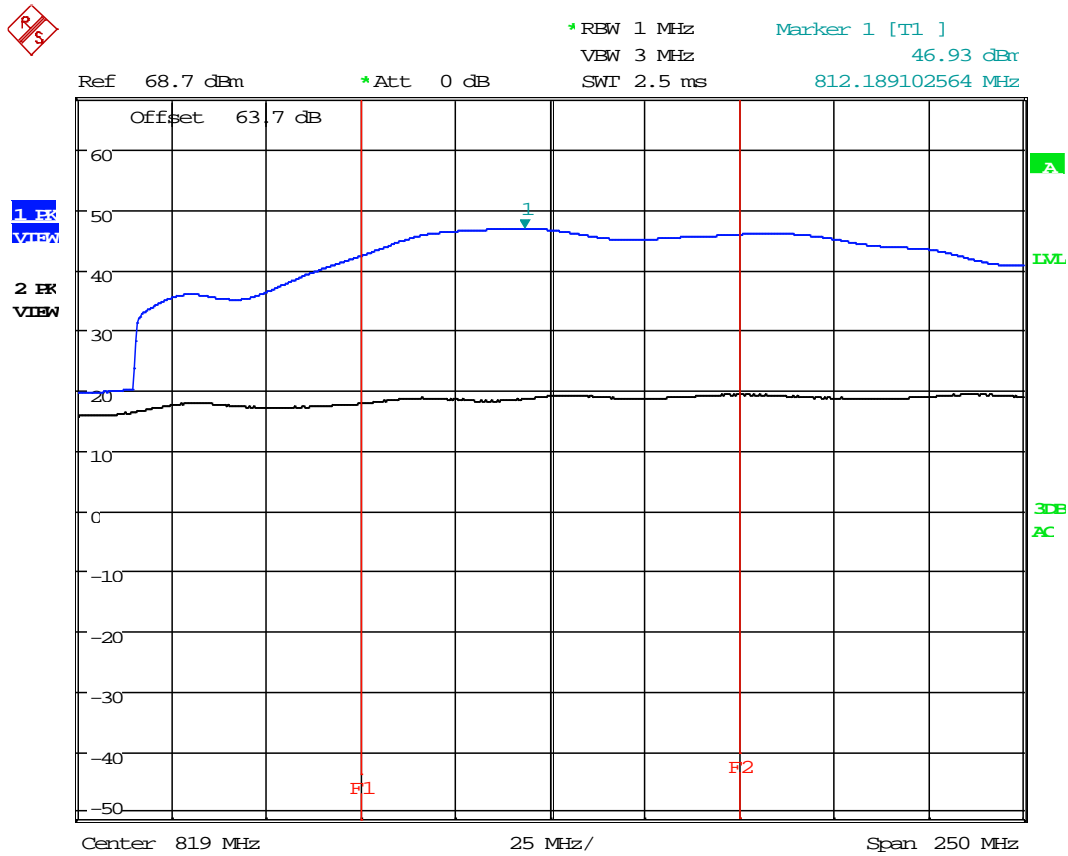

Date: 28.AUG.2019 13:21:12

Trace 1 (Blue): Public Safety Block(s) @ AGC
Trace 2 (Black): Public Safety Block(s) @ AGC -3 dB

RESULT:

FCC CLASS B SIGNAL BOOSTER DEVICE (Amplifier with ≥ 75 kHz Passband)

OPERATING FREQUENCY RANGE = 769 - 869 MHz

Note: The operating frequency range is limited to the certified licensed PLMRS/PSRS 769 – 869 MHz equipment which will be used in conjunction with this amplifier.

OUT OF BAND REJECTION

Test Data: Out of Band Rejection, Equipment Functional Band

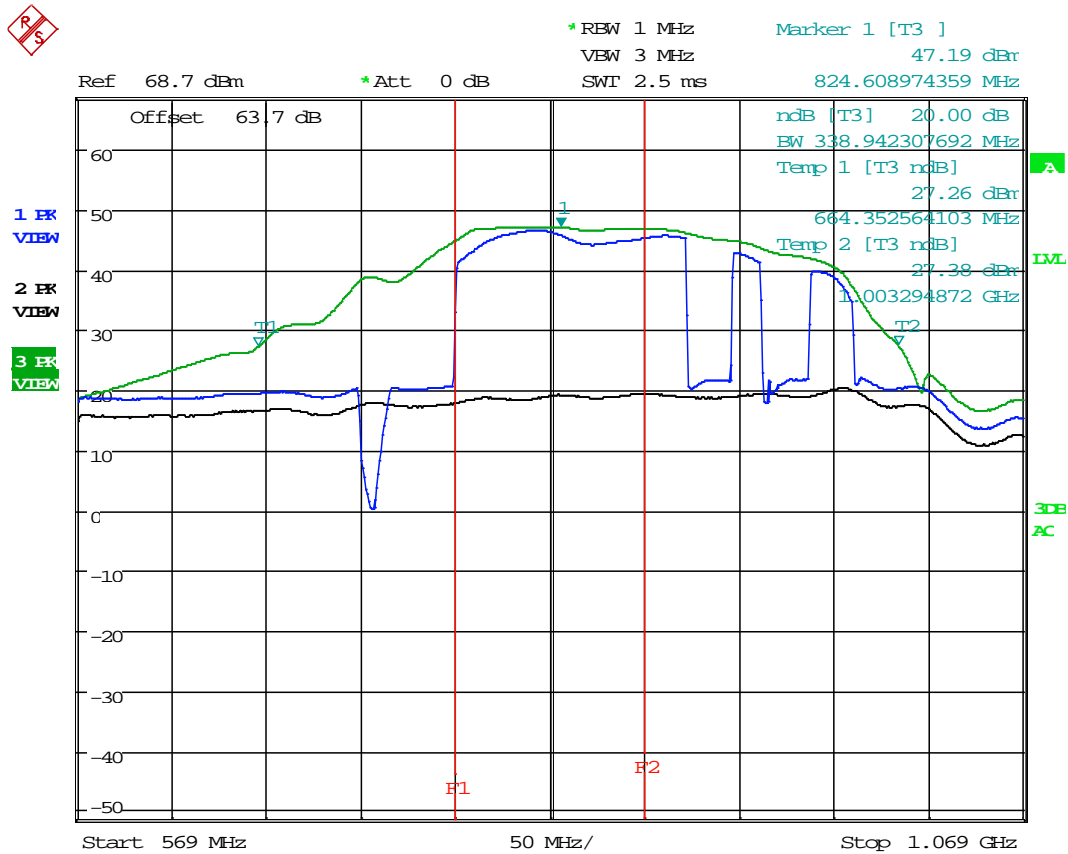

Date: 28.AUG.2019 13:32:18

Trace 3 (Green): Full sweep @ AGC +3 dB
 Trace 1 (Blue): Full sweep @ AGC
 Trace 2 (Black): Full sweep @ AGC -3 dB

RESULT:

The AGC level in the EUT operational band was consistent all throughout the band.

Outside the band, the amplifier had intermittent amplification outside the intended band.

+3 dB above AGC, the amplifier amplified all signals in the functional range.

OUT OF BAND REJECTION

Test Data: Out of Band Rejection, Equipment Functional Band @ Max Power

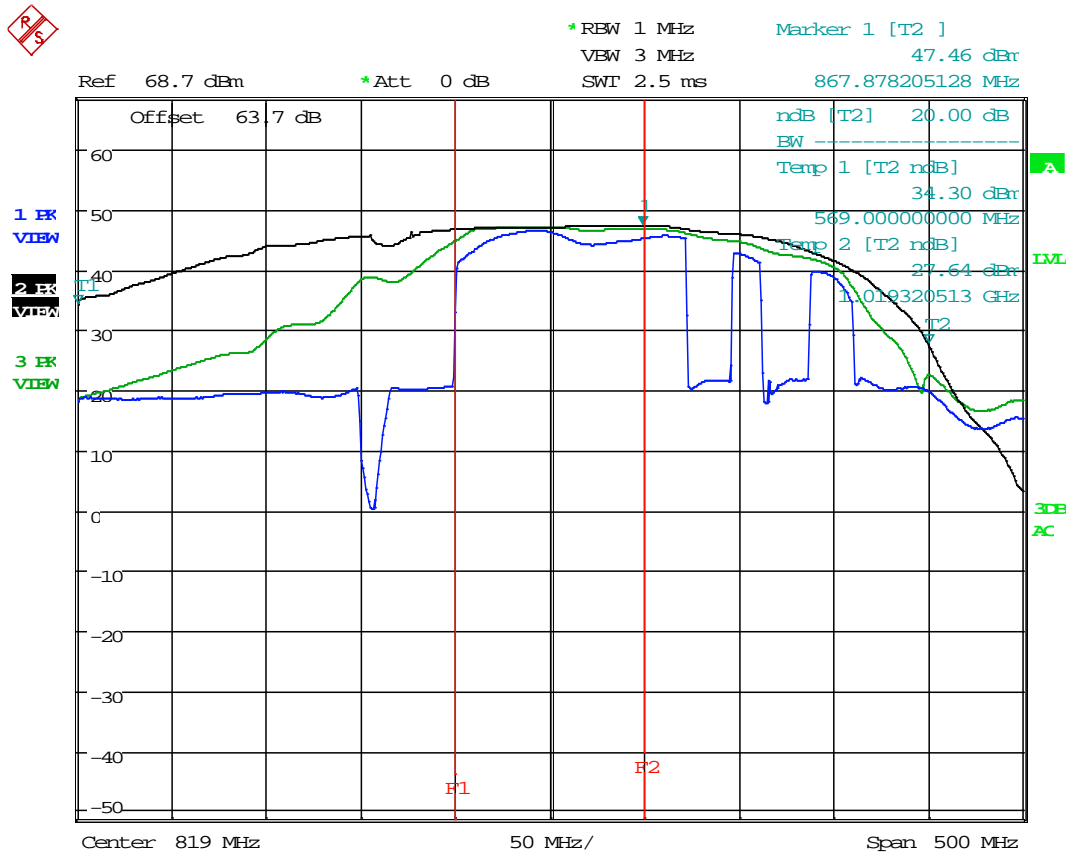

Date: 28.AUG.2019 13:36:35

Trace 2 (Black): Full sweep @ AGC +14 dB (Max Input Power)

Trace 3 (Green): Full sweep @ AGC +3 dB

Trace 1 (Blue): Full sweep @ AGC

RESULT:

The EUT was given full input power (+36 dBm) and results were taken.

Outside the band, the amplifier had a greater response, but did not exceed rated power by more than the tuning tolerance.

Peak power was still inside the Operational band, @ 867.88 MHz.

A sharp decrease was observed near 1 GHz at full power, but spurious emissions above 1 GHz were found to be greater at full power.

Applicant: CRESCEND TECHNOLOGIES, LLC
 FCC ID: CWW DSSTJK50
 Report: 2233AUT19TestReport_Rev1

INPUT VS OUTPUT COMPARISON

Rule Part No.: KDB 935210 s.4.4, FCC Pt. 2.1049(h), FCC Pt. 90.219(e)(4)(ii),
FCC Pt. 90.219(e)(4)(iii), FCC Pt. 90.210(c)

Compliance with the emission mask of the EUT output shall be measured for the public safety service signal types as specified in 4.1.

Refer to the applicable regulatory requirements (e.g., Section 90.210) for emission mask specifications.

Requirements:

(e) *Device Specifications.* In addition to the general rules for equipment certification in §90.203(a)(2) and part 2, subpart J of this chapter, a signal booster must also meet the rules in this paragraph.

(4) A signal booster must be designed such that all signals that it retransmits meet the following requirements:

(ii) There is no change in the occupied bandwidth of the retransmitted signals.

(iii) The retransmitted signals continue to meet the unwanted emissions limits of §90.210 applicable to the corresponding received signals (assuming that these received signals meet the applicable unwanted emissions limits by a reasonable margin).

FCC CFR 47 Part 90 Emission Masks						
Frequency Band (MHz)	Mask for equipment with audio low pass filter			Mask for equipment without audio low pass filter		
	6.25 kHz	12.5 kHz	25 kHz	6.25 kHz	12.5 kHz	25 kHz
806 - 809	B, 20 kHz ABW			H, 20 kHz ABW		
809 - 817	D, 11.25 kHz ABW		B, 20 kHz ABW	D, 11.25 kHz ABW		G, 20 kHz ABW
817 - 824	D, 20 kHz ABW		B, 20 kHz ABW	D, 20 kHz ABW		G, 20 kHz ABW
851 - 854	B, 20 kHz ABW			H, 20 kHz ABW		
854 - 862	D, 11.25 kHz ABW		B, 20 kHz ABW	D, 11.25 kHz ABW		G, 20 kHz ABW
862 - 869	D, 20 kHz ABW		B, 20 kHz ABW	D, 20 kHz ABW		G, 20 kHz ABW
All other bands	B			C		

The frequencies for Input Vs Output shall be as follows:

Test Frequency	Mask Band	Mask	Operating Band	Signal(s)
772 MHz	"All other Bands"	Mask C	769 – 775 MHz	All
802 MHz	"All other Bands"	Mask C	799 – 805 MHz	All
807.5 MHz	806 - 809	Mask H	806 – 824 MHz	All
816.5 MHz	809 – 824	Mask D	806 – 824 MHz	≤ 12.5 kHz
816.5 MHz	809 – 824	Mask G	806 – 824 MHz	> 12.5 kHz
852.5 MHz	851 - 854	Mask H	851 – 869 MHz	All
861.5 MHz	854 - 869	Mask D	851 – 869 MHz	≤ 12.5 kHz
861.5 MHz	854 - 869	Mask G	851 – 869 MHz	> 12.5 kHz

INPUT VS OUTPUT COMPARISON

Test Procedure: KDB 935210 s.4.4

- a) Connect a signal generator to the input of the EUT.
- b) Configure the signal generator to transmit the appropriate test signal associated with the public safety emission designation (see Table 1).
- c) Configure the signal level to be just below the AGC threshold (see results from 4.2).
- d) Connect a spectrum analyzer to the output of the EUT using appropriate attenuation as necessary.
- e) Set the spectrum analyzer center frequency to the nominal EUT channel center frequency. The span range for the spectrum analyzer shall be between 2 times to 5 times the EBW (or OBW).
- f) The nominal RBW shall be 300 Hz for 16K0F3E, and 100 Hz for all other emissions types.
- g) Set the reference level of the spectrum analyzer to accommodate the maximum input amplitude level, i.e., the level at f_0 per 4.2.
- h) Set spectrum analyzer detection mode to peak, and trace mode to max hold.
- i) Allow the trace to fully stabilize.
- j) Confirm that the signal is contained within the appropriate emissions mask.
- k) Use the marker function to determine the maximum emission level and record the associated frequency as f_0 .
- l) Capture the emissions mask plot for inclusion in the test report (output signal spectra).
- m) Measure the EUT input signal power (signal generator output signal) directly from the signal generator using power measurement guidance provided in KDB Publication 971168 [R8] (input signal spectra).
- n) Compare the spectral plot of the output signal (determined in step k), to the input signal (determined in step l) to affirm they are similar (in passband and rolloff characteristic features and relative spectral locations).
- o) Repeat steps d) to n) with the input signal amplitude set 3 dB above the AGC threshold.
- p) Repeat steps b) to o) for all authorized operational bands and emissions types (see applicable regulatory specifications, e.g., Section 90.210).
- q) Include all accumulated spectral plots depicting EUT input signal and EUT output signal in the test report, and note any observed dissimilarities.

Test Setup Block Diagram: KDB 935210 s.4.4

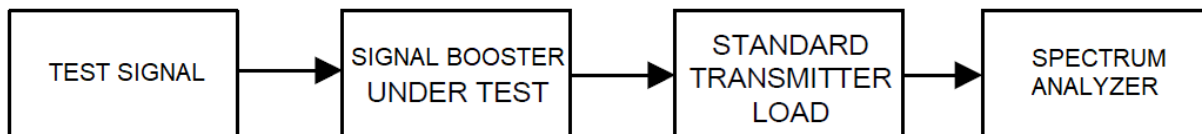

INPUT VS OUTPUT COMPARISON

Emission Mask Calculation: FCC Pt. 90.210

Calculation	Limit (dBc)	dBc	dBm
#2 (Mask C)	$83 * \text{Log}(5 / 5)$	0.00	47.00
	$83 * \text{Log}(10 / 5)$	24.99	22.01
	Min dBc of: 50 or $29 * \text{Log}(10^2 / 11)$	27.80	19.20
	Min dBc of: 50 or $29 * \text{Log}((250\% \text{ ABW})^2 / 11)$	50.00	-3.00
#3 (Mask D)	$7.27(5.625 - 2.88)$	19.96	27.04
	$7.27(12.5 - 2.88)$	69.94	-22.94
#6 (Mask G)	Min dBc of: 70 or $50 + 10 * \text{Log}(P)$ or $116 * \text{Log}(10 / 6.1)$	24.90	22.10
	Min dBc of: 70 or $50 + 10 * \text{Log}(P)$ or $116 * \text{Log}((250\% \text{ ABW}) / 6.1)$	67.00	-20.00
#7 (Mask H)	$107 * \text{Log}(4 / 4)$	0.00	47.00
	$107 * \text{Log}(8.5 / 4)$	35.03	11.97
	$40.5 * \text{Log}(8.5 / 1.16)$	35.03	11.97
	$40.5 * \text{Log}(15 / 1.16)$	45.02	1.98
	$116 * \text{Log}(15 / 6.1)$	45.33	1.67
	$116 * \text{Log}(25 / 6.1)$	71.06	-24.06

INPUT VS OUTPUT COMPARISON

Emission Mask Calculation: FCC Pt. 90.210(c)

MASK C, 6.250 kHz Authorized BW			
Requirement	f_d (kHz)	Level (dBc)	Level (dBm)
$\geq 250\%$ of ABW, see #1	≤ -15.625	60.00	-13.00
-10 kHz to -250% of ABW, see #2	-15.625	50.00	-3.00
	-10	27.80	19.20
-5 kHz to -10 kHz, see #2	-10	24.99	22.01
	-5	0.00	47.00
(Fundamental)	0		
+5 kHz to +10 kHz, see #2	+5	24.99	22.01
	+10		
+10 kHz to +250% of ABW, see #2	+10	27.80	19.20
	+15.625	50.00	-3.00
$\geq 250\%$ of ABW, see #1	$\geq +15.625$	60.00	-13.00

MASK C, 12.5 kHz Authorized BW			
Requirement	f_d (kHz)	Level (dBc)	Level (dBm)
$\geq 250\%$ of ABW, see #1	≤ -31.25	60.00	-13.00
-10 kHz to -250% of ABW, see #2	-31.25	50.00	-3.00
	-10	27.80	19.20
-5 kHz to -10 kHz, see #2	-10	24.99	22.01
	-5	0.00	47.00
(Fundamental)	0		
+5 kHz to +10 kHz, see #2	+5	24.99	22.01
	+10		
+10 kHz to +250% of ABW, see #2	+10	27.80	19.20
	+31.25	50.00	-3.00
$\geq 250\%$ of ABW, see #1	$\geq +31.25$	60.00	-13.00

MASK C, 20 kHz Authorized BW			
Requirement	f_d (kHz)	Level (dBc)	Level (dBm)
$\geq 250\%$ of ABW, see #1	≤ -50	60.00	-13.00
-10 kHz to -250% of ABW, see #2	-50	50.00	-3.00
	-10	27.80	19.20
-5 kHz to -10 kHz, see #2	-10	24.99	22.01
	-5	0.00	47.00
(Fundamental)	0		
+5 kHz to +10 kHz, see #2	+5	24.99	22.01
	+10		
+10 kHz to +250% of ABW, see #2	+10	27.80	19.20
	+50	50.00	-3.00
$\geq 250\%$ of ABW, see #1	$\geq +50$	60.00	-13.00

INPUT VS OUTPUT COMPARISON

Emission Mask Calculation: FCC Pt. 90.210(d)

MASK D, 11.25/20 kHz ABW			
Requirement	f_d (kHz)	Level (dBc)	Level (dBm)
≤ -12.5 kHz, see #3	≤ -12.5	60.00	-13.00
- 5.625 kHz to -12.5 kHz, see #3	-12.5	69.94	-22.94
	-5.625	19.96	27.04
-5.625 kHz > fundamental < +5.625 kHz, 0 dBc	-5.625	0.00	47.00
	0		
	+ 5.625		
+ 5.625 kHz to +12.5 kHz, see #3	+ 5.625	19.96	27.04
	+ 12.5	69.94	-22.94
$\geq +12.5$ kHz, see #3	$\geq + 12.5$	60.00	-13.00

Emission Mask Calculation: FCC Pt. 90.210(g)

MASK G, 20 kHz ABW			
Requirement	f_d (kHz)	Level (dBc)	Level (dBm)
$\geq 250\%$ of ABW, see #1	≤ -50	60.00	-13.00
-10 kHz to -250% of ABW, see #6	-50	67.00	-20.00
	-10	24.90	22.10
(Fundamental)	0	0.00	47.00
+10 kHz to +250% of ABW, see #6	+ 10	24.90	22.10
	+ 50	67.00	-20.00
$\geq 250\%$ of ABW, see #1	$\geq + 50$	60.00	-13.00

INPUT VS OUTPUT COMPARISON

Emission Mask Calculation: FCC Pt. 90.210(h)

MASK H, 20 kHz Authorized BW			
Requirement	f_d (kHz)	Level (dBc)	Level (dBm)
≤ -25 kHz, see #1	≤ -25	60.00	-13.00
-15 kHz to -25 kHz, see #7	-25	71.06	-24.06
	-15	45.33	1.67
-8.5 kHz to -15 kHz, see #7	-15	45.02	1.98
	-8.5	35.03	11.97
-4 kHz to -8.5 kHz, see #7	-8.5	35.03	11.97
	-4	0.00	47.00
-4 kHz > fundamental < +4 kHz, 0 dBc	-4	0.00	47.00
	0		
	+ 4		
+ 3 kHz to +4.6 kHz, see #4	+ 4	0.00	47.00
	+ 8.5	35.03	11.97
+ 3 kHz to +4.6 kHz, see #4	+ 8.5	35.03	11.97
	+ 15	45.02	1.98
+ 3 kHz to +4.6 kHz, see #4	+ 15	45.33	1.67
	+ 25	71.06	-24.06
≥ 25 kHz, see #1	$\geq + 25$	60.00	-13.00

INPUT VS OUTPUT COMPARISON

772 MHz

Test Data: 4K00F3E Output Signal, @ AGC

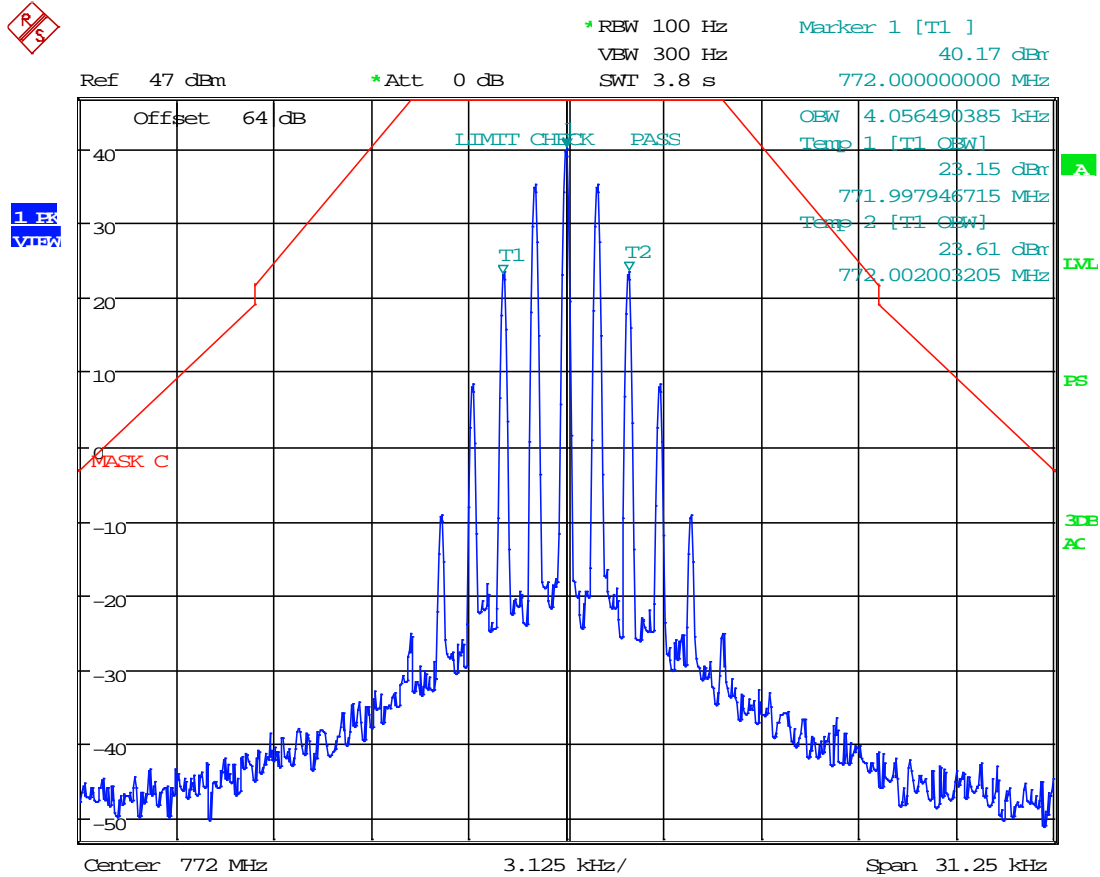

Date: 27.AUG.2019 11:08:23

RESULT: AGC Output Signal 99% OBW = 4.06 kHz

INPUT VS OUTPUT COMPARISON

Test Data: 4K00F3E Output Signal, @ AGC +14 dBm (Max Input Power)

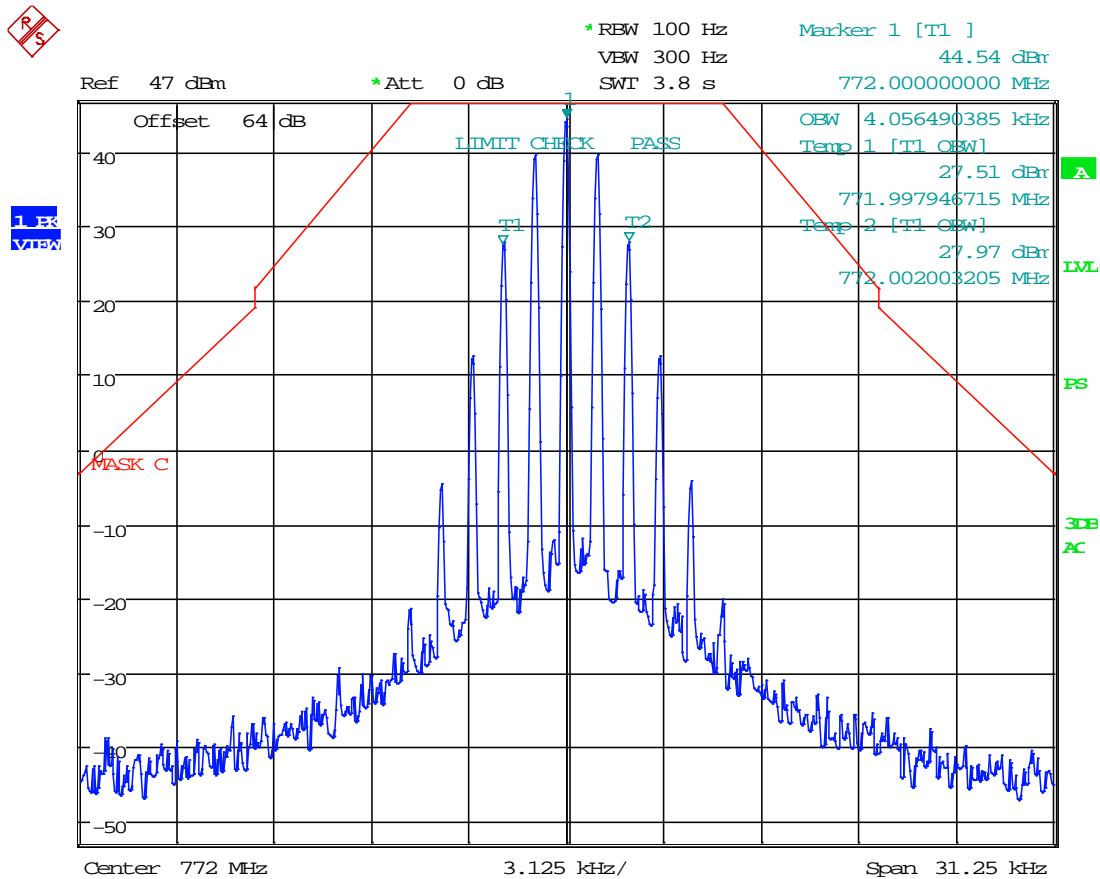

Date: 27.AUG.2019 11:09:04

RESULT: AGC+ 14 Output Signal 99% OBW = 4.06 kHz

INPUT VS OUTPUT COMPARISON

Test Data: 8K10F1E/F1D Output Signal, @ AGC

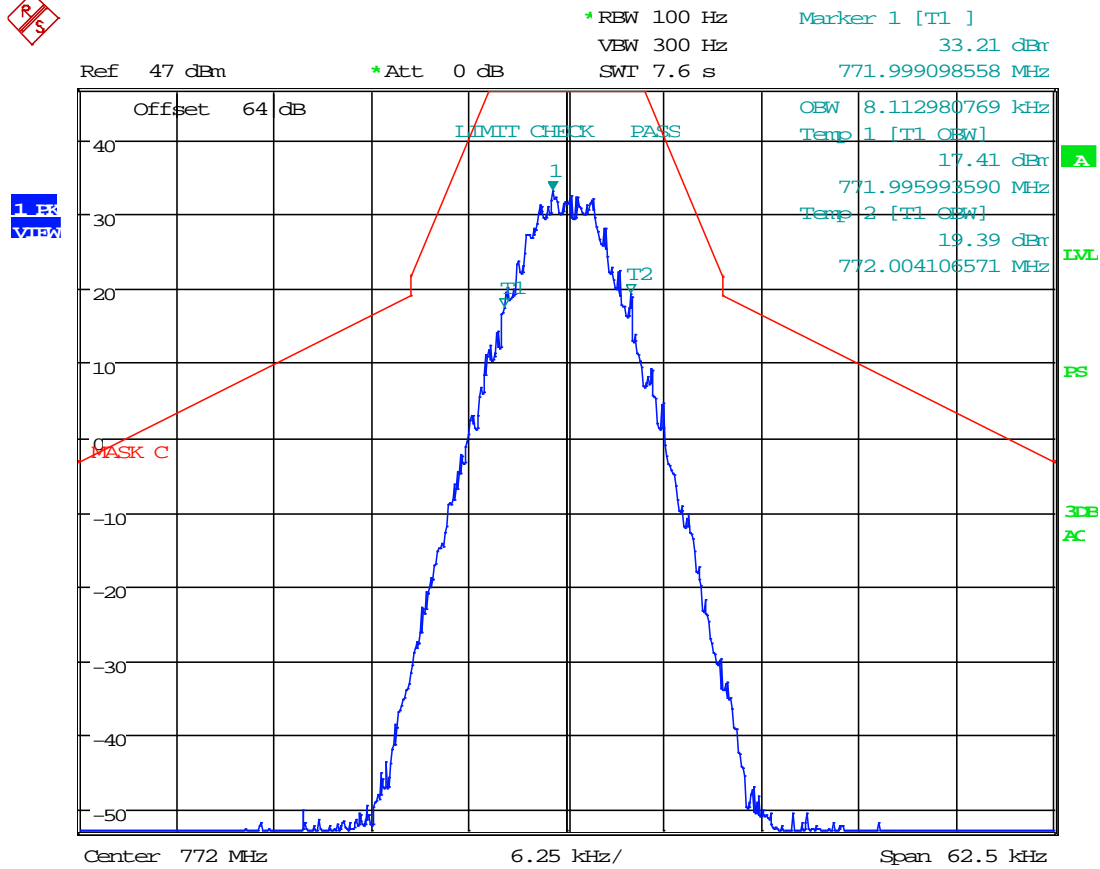

Date: 27.AUG.2019 13:45:59

RESULT: AGC Output Signal 99% OBW = 8.11 kHz

INPUT VS OUTPUT COMPARISON

Test Data: 8K10F1W Output Signal, @ AGC

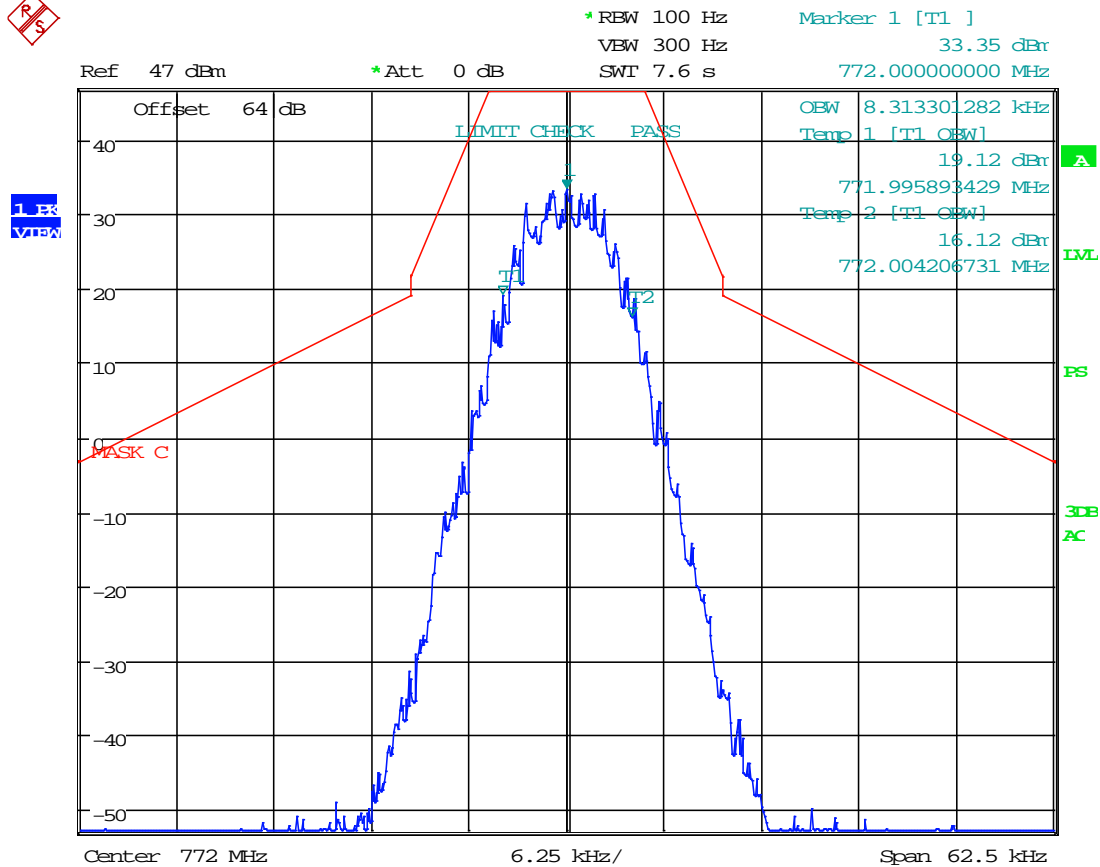

Date: 27.AUG.2019 13:36:49

RESULT: AGC Output Signal 99% OBW = 8.31 kHz

INPUT VS OUTPUT COMPARISON

Test Data: 11K3F3E Output Signal, @ AGC

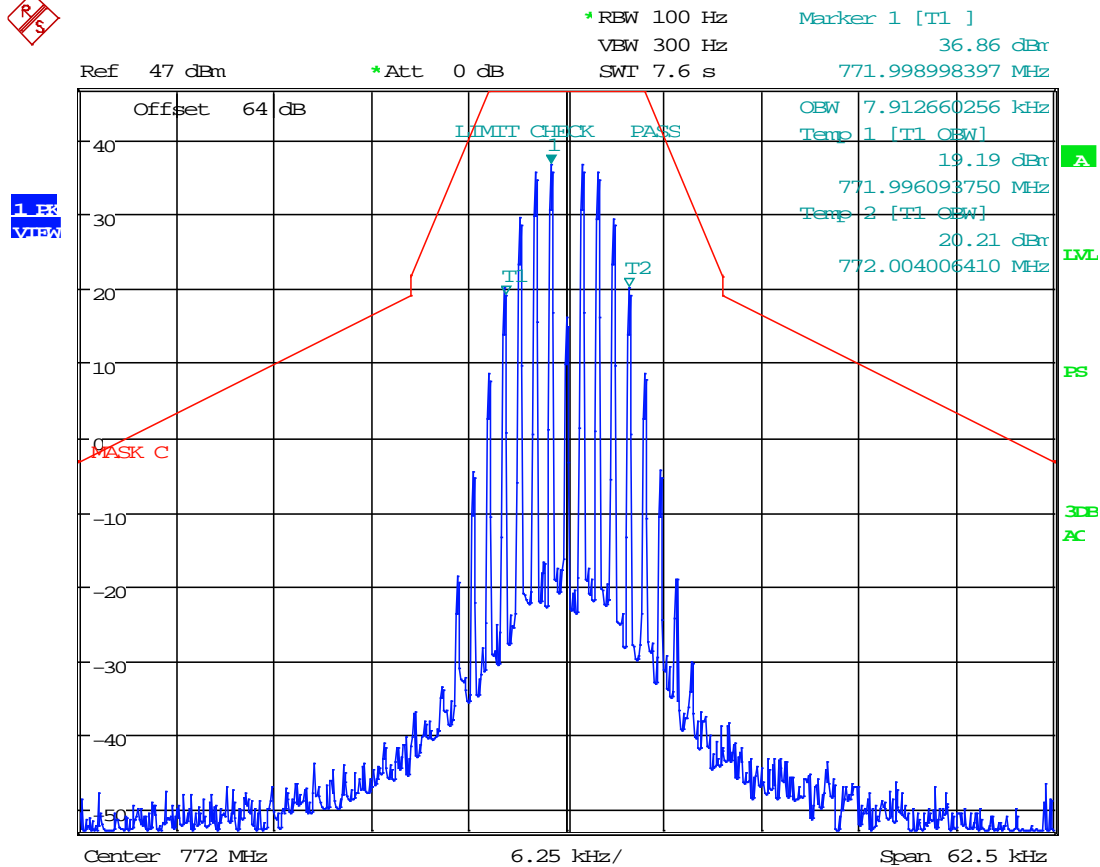

Date: 27.AUG.2019 12:18:07

RESULT: AGC Output Signal 99% OBW = 7.91 kHz

INPUT VS OUTPUT COMPARISON

Test Data: 11K3F3E Output Signal, @ AGC +14 dBm (Max Input Power)

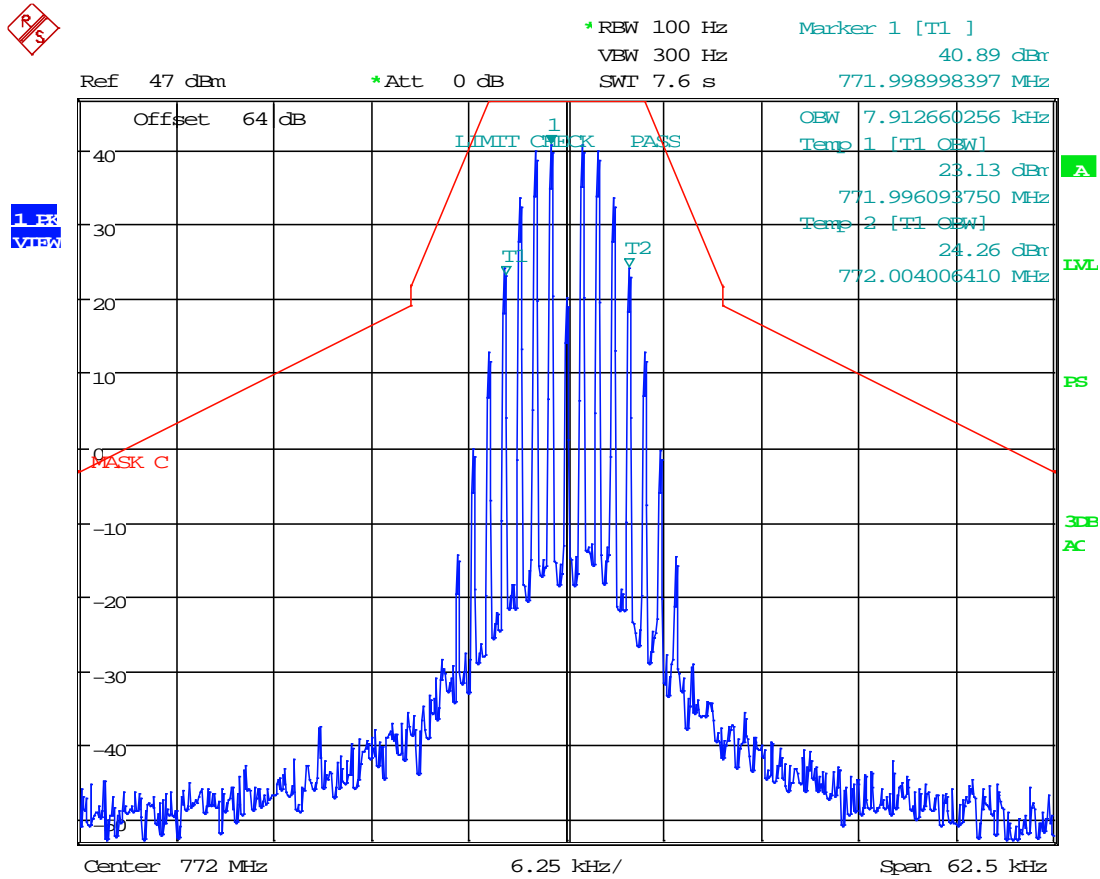

Date: 27.AUG.2019 12:29:25

RESULT: AGC+14 Output Signal 99% OBW = 7.91 kHz

INPUT VS OUTPUT COMPARISON

Test Data: 16K0F3E Output Signal, @ AGC

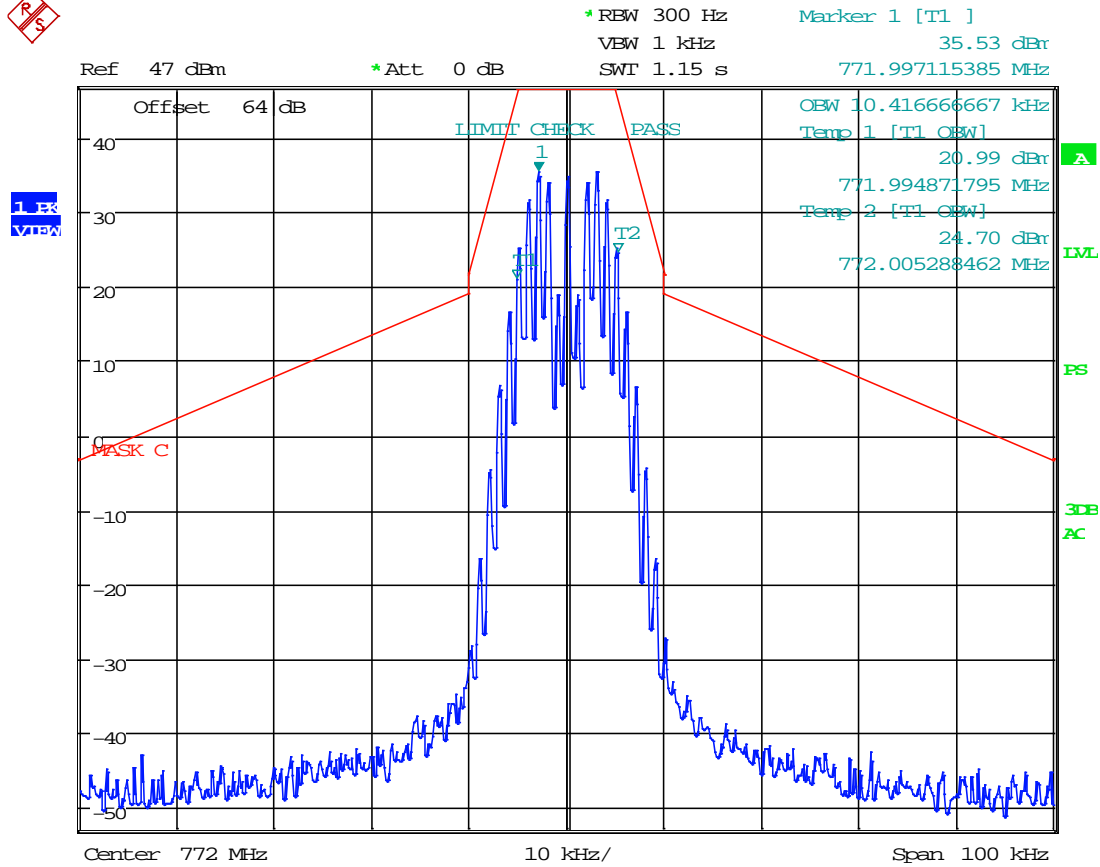

Date: 27.AUG.2019 14:57:08

RESULT: AGC Output Signal 99% OBW = 10.42 kHz

INPUT VS OUTPUT COMPARISON

Test Data: 16K0F3E Output Signal, @ AGC +14 dBm (Max Input Power)

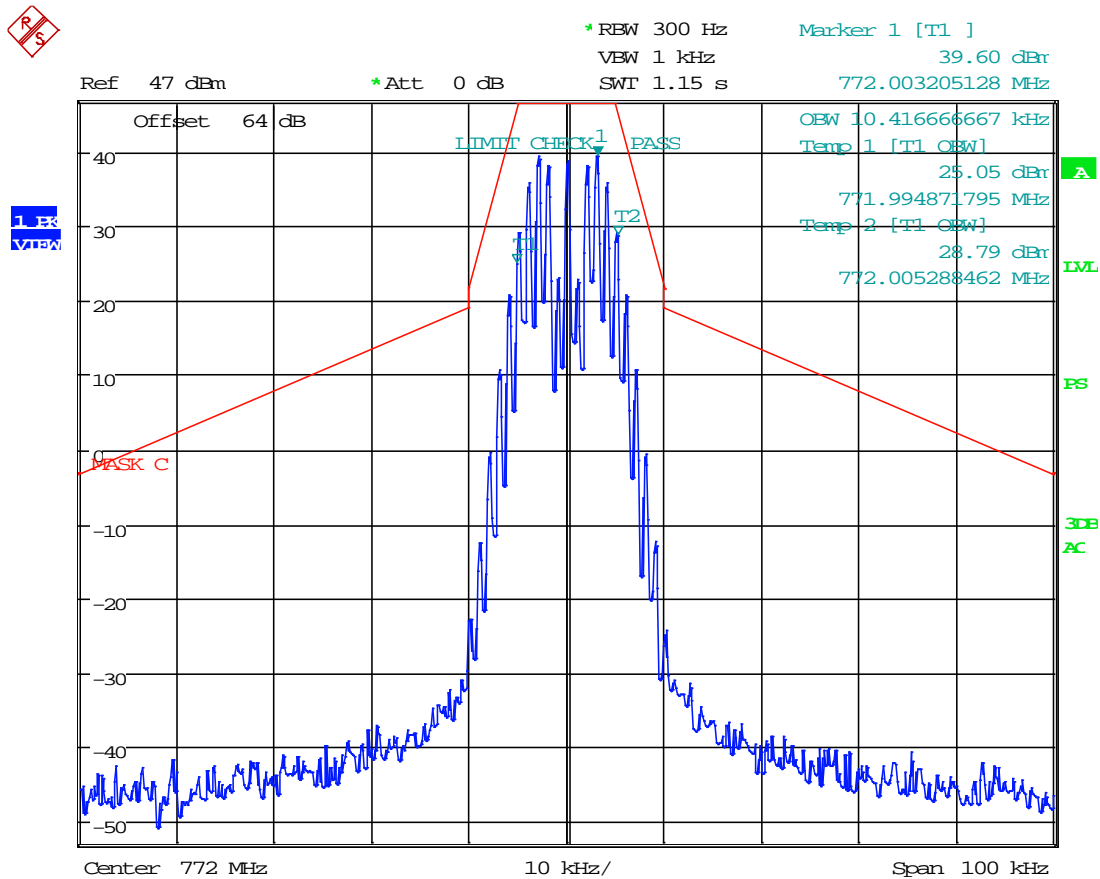

Date: 27.AUG.2019 14:57:47

RESULT: AGC+ 14 Output Signal 99% OBW = 10.42 kHz

INPUT VS OUTPUT COMPARISON

802 MHz

Test Data: 4K00F3E Output Signal, @ AGC

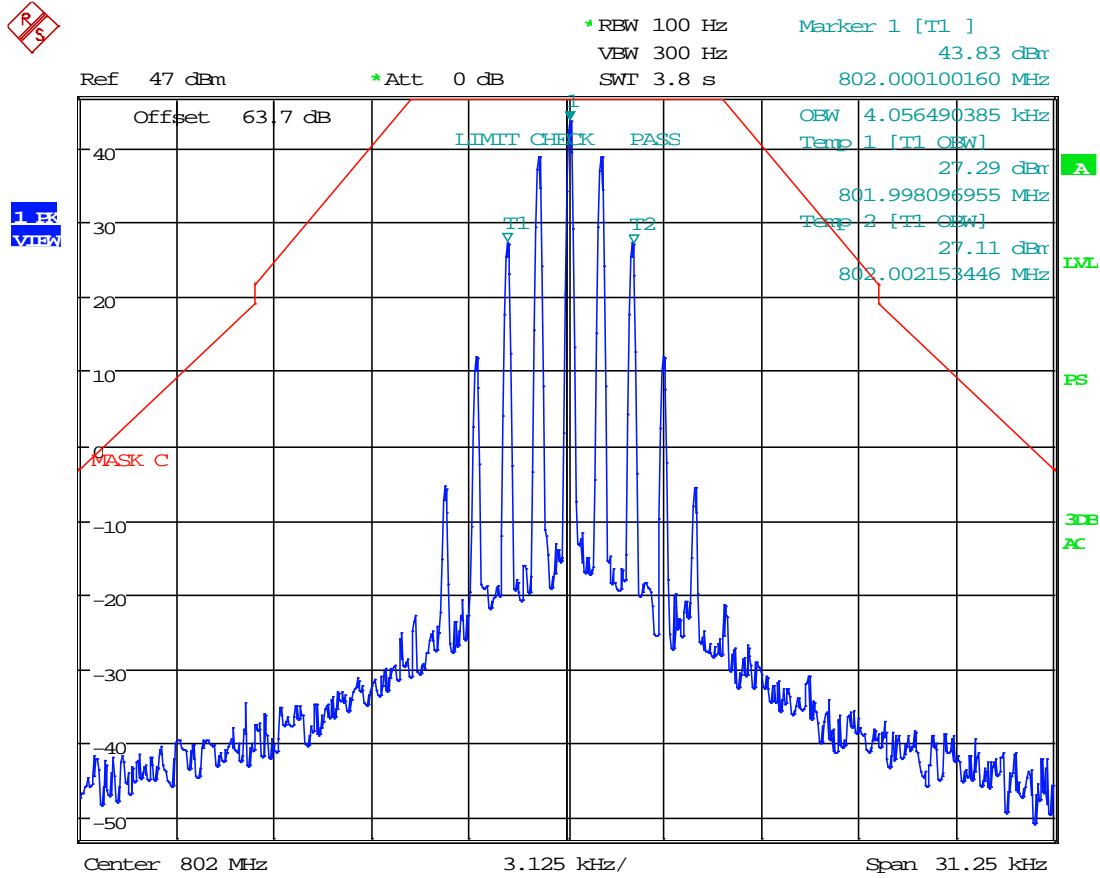

Date: 27.AUG.2019 15:19:49

RESULT: AGC Output Signal 99% OBW = 4.06 kHz

INPUT VS OUTPUT COMPARISON

Test Data: 8K10F1E/F1D Output Signal, @ AGC

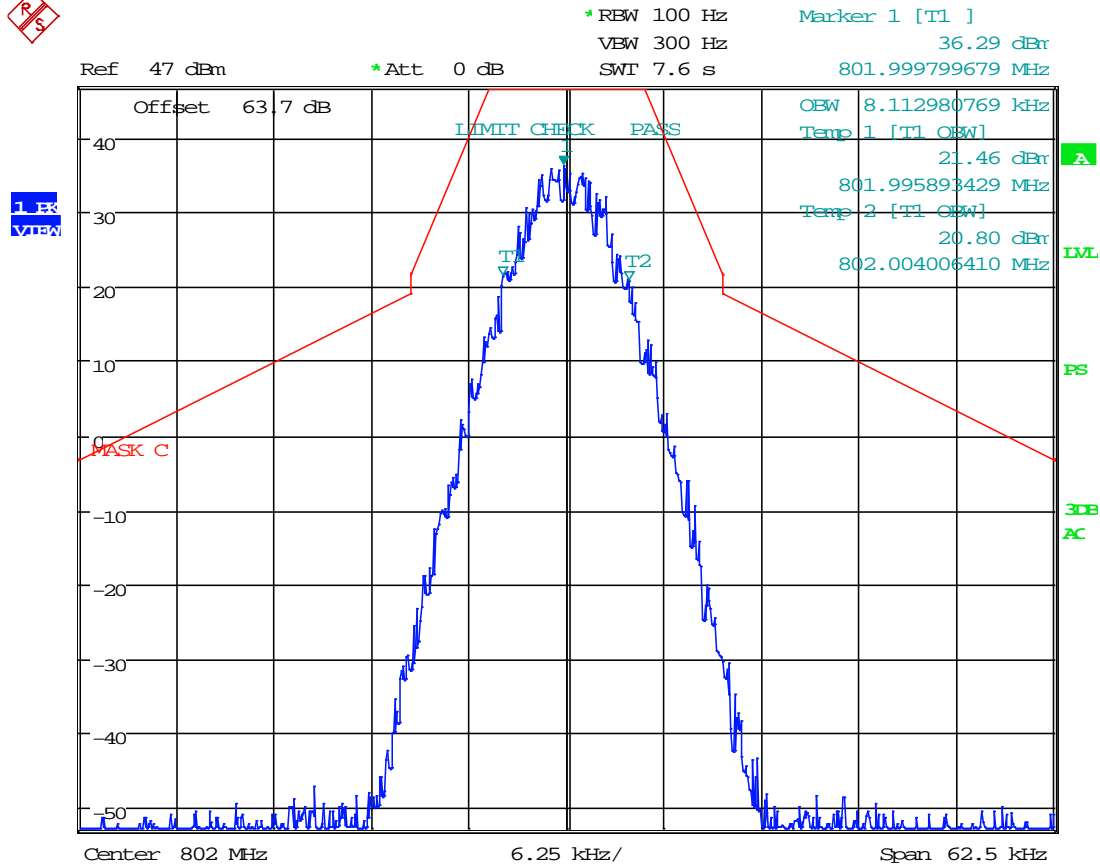

Date: 27.AUG.2019 15:05:13

RESULT: AGC Output Signal 99% OBW = 8.11 kHz

INPUT VS OUTPUT COMPARISON

Test Data: 8K10F1W Output Signal, @ AGC

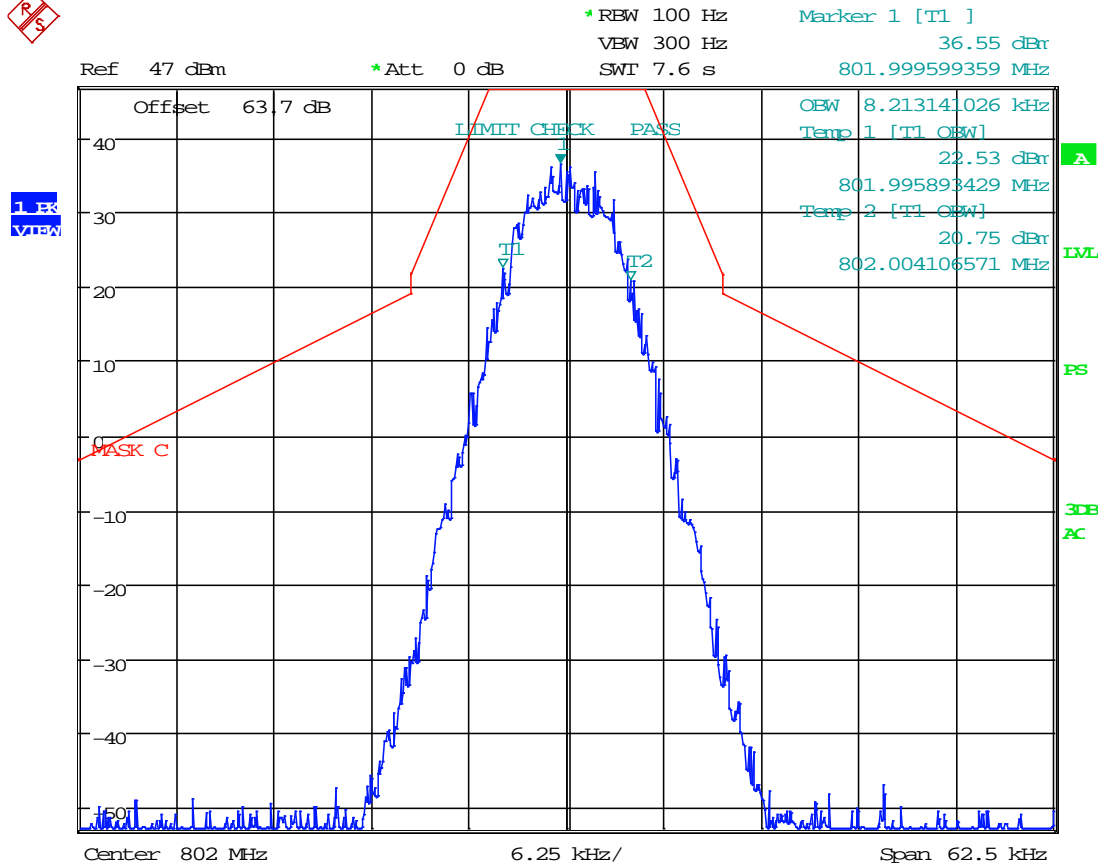

Date: 27.AUG.2019 15:14:54

RESULT: AGC Output Signal 99% OBW = 8.21 kHz

INPUT VS OUTPUT COMPARISON

Test Data: 8K10F1W Output Signal, @ AGC +14 dBm (Max Input Power)

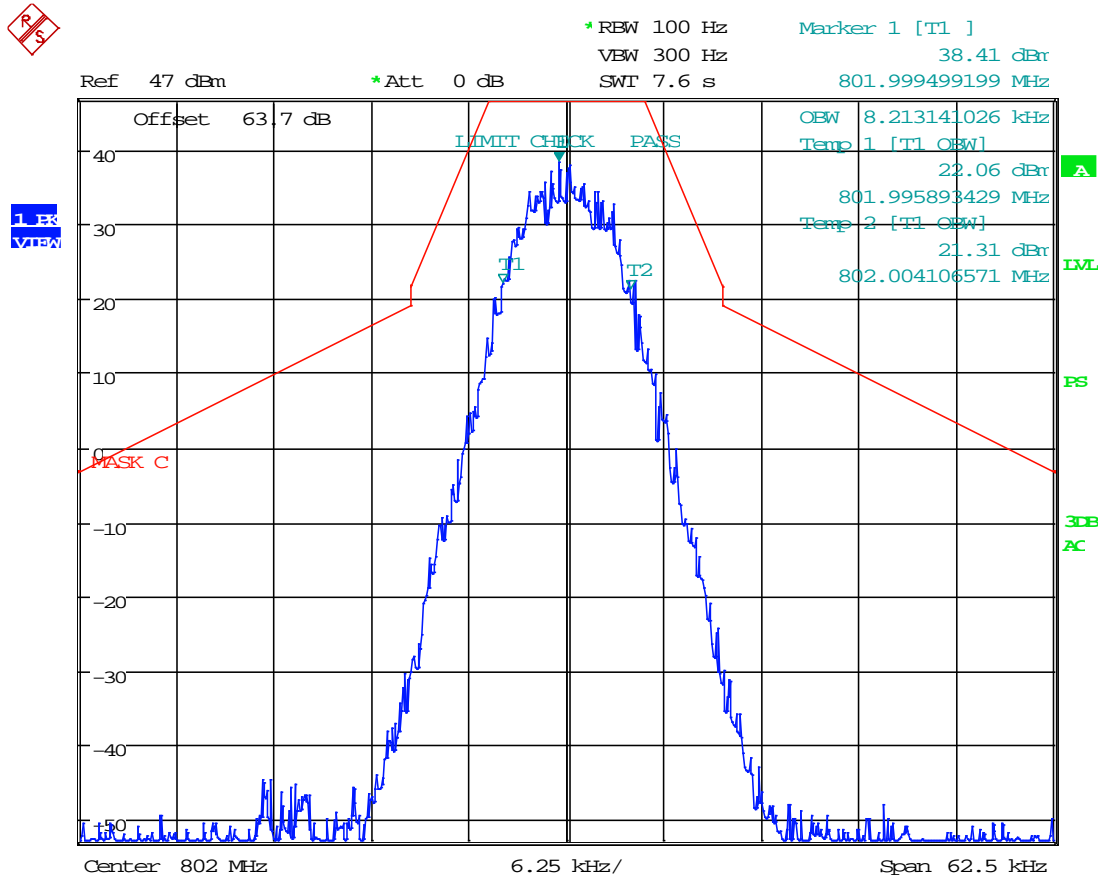

Date: 27.AUG.2019 15:14:03

RESULT: AGC+14 Output Signal 99% OBW = 8.21 kHz

INPUT VS OUTPUT COMPARISON

Test Data: 11K3F3E Output Signal, @ AGC +14 dBm (Max Input Power)

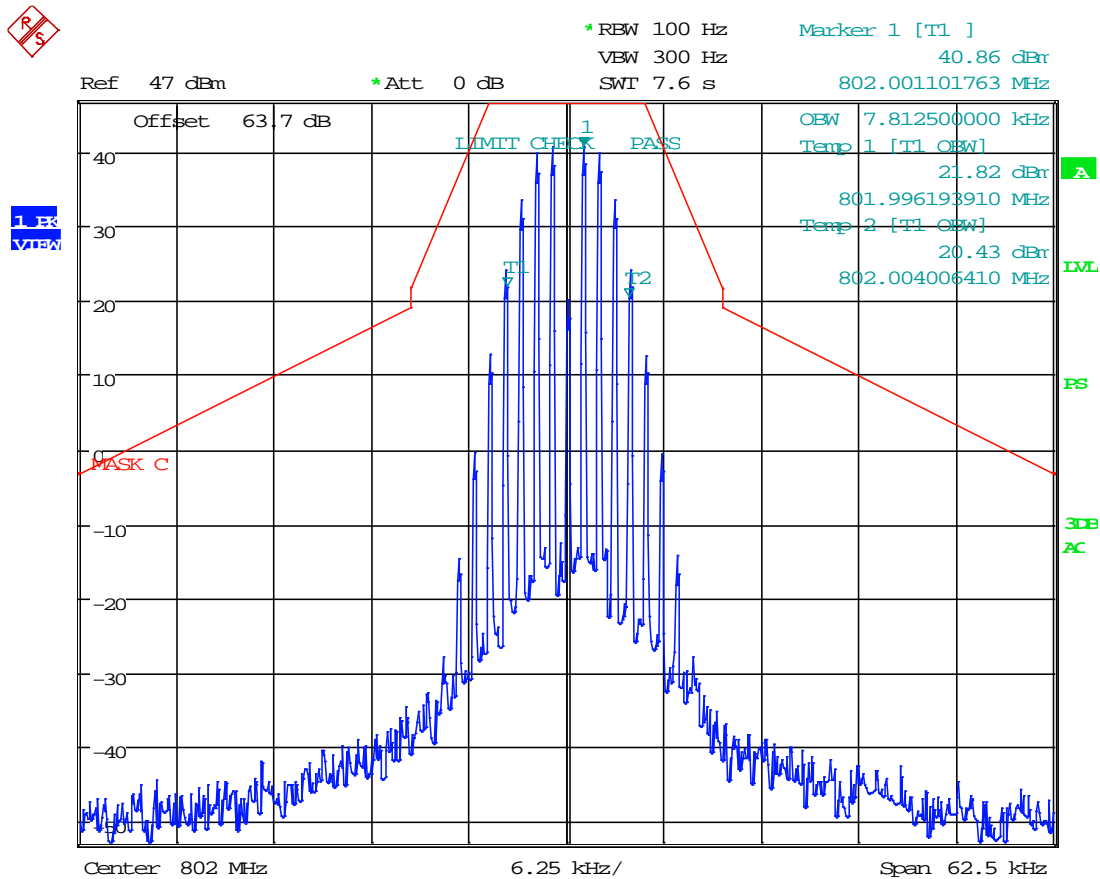

Date: 27.AUG.2019 15:03:53

RESULT: AGC+14 Output Signal 99% OBW = 7.81 kHz

INPUT VS OUTPUT COMPARISON

Test Data: 16K0F3E Output Signal, @ AGC

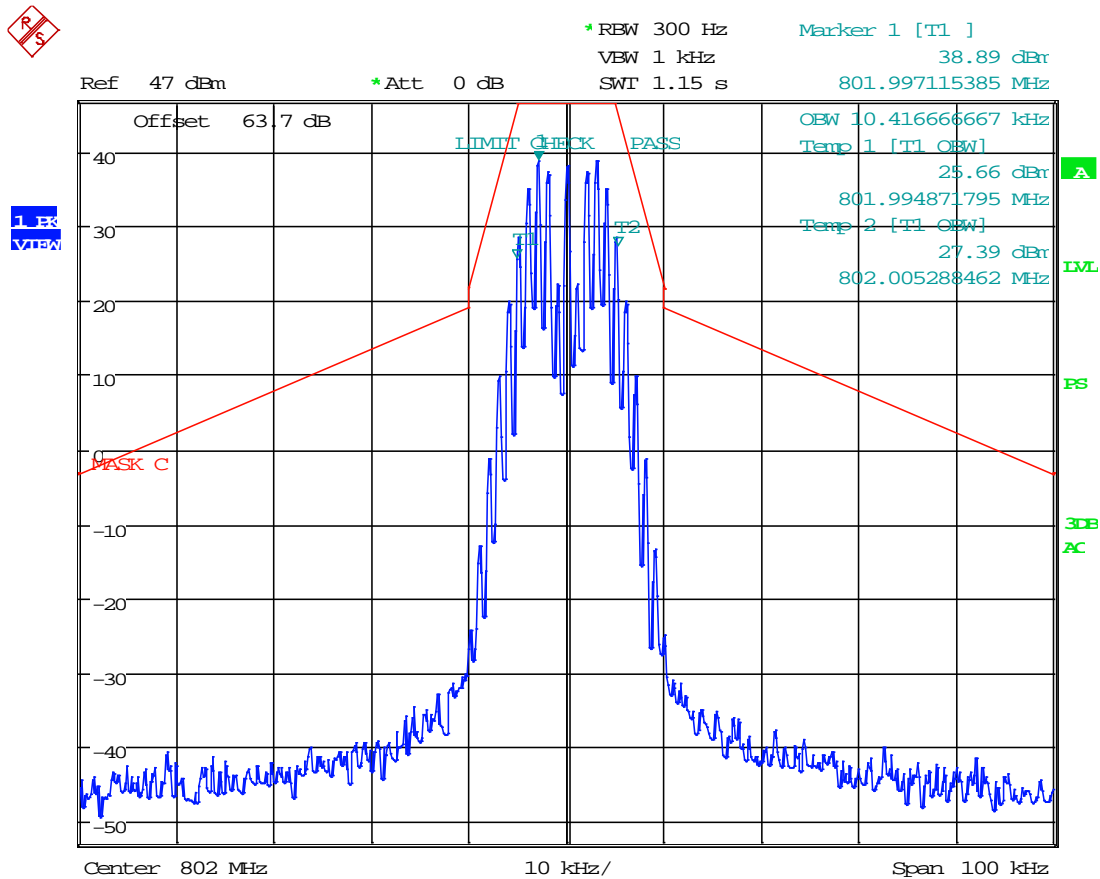

Date: 27.AUG.2019 15:01:02

RESULT: AGC Output Signal 99% OBW = 10.42 kHz

INPUT VS OUTPUT COMPARISON

807.5 MHz

Test Data: 4K00F3E Output Signal, @ AGC

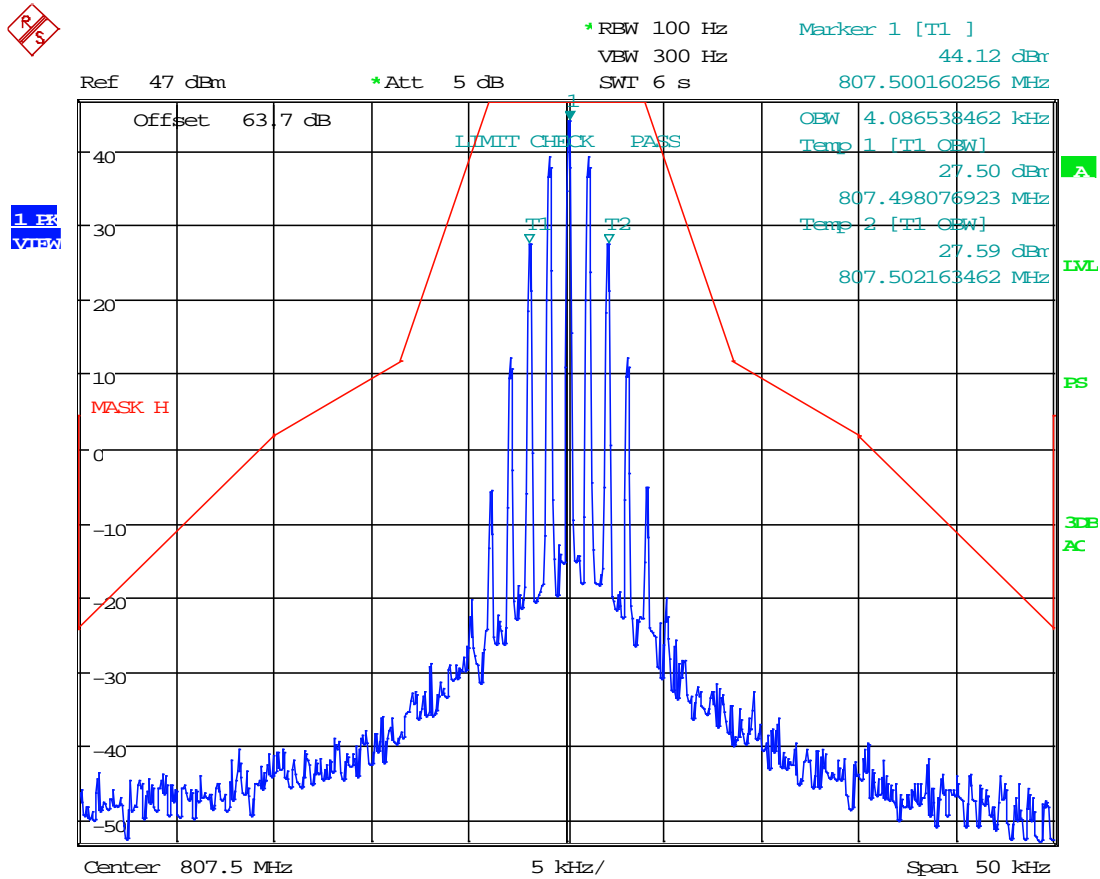

Date: 27.AUG.2019 15:58:28

RESULT: AGC Output Signal 99% OBW = 4.09 kHz

INPUT VS OUTPUT COMPARISON

Test Data: 8K10F1E/F1D Output Signal, @ AGC

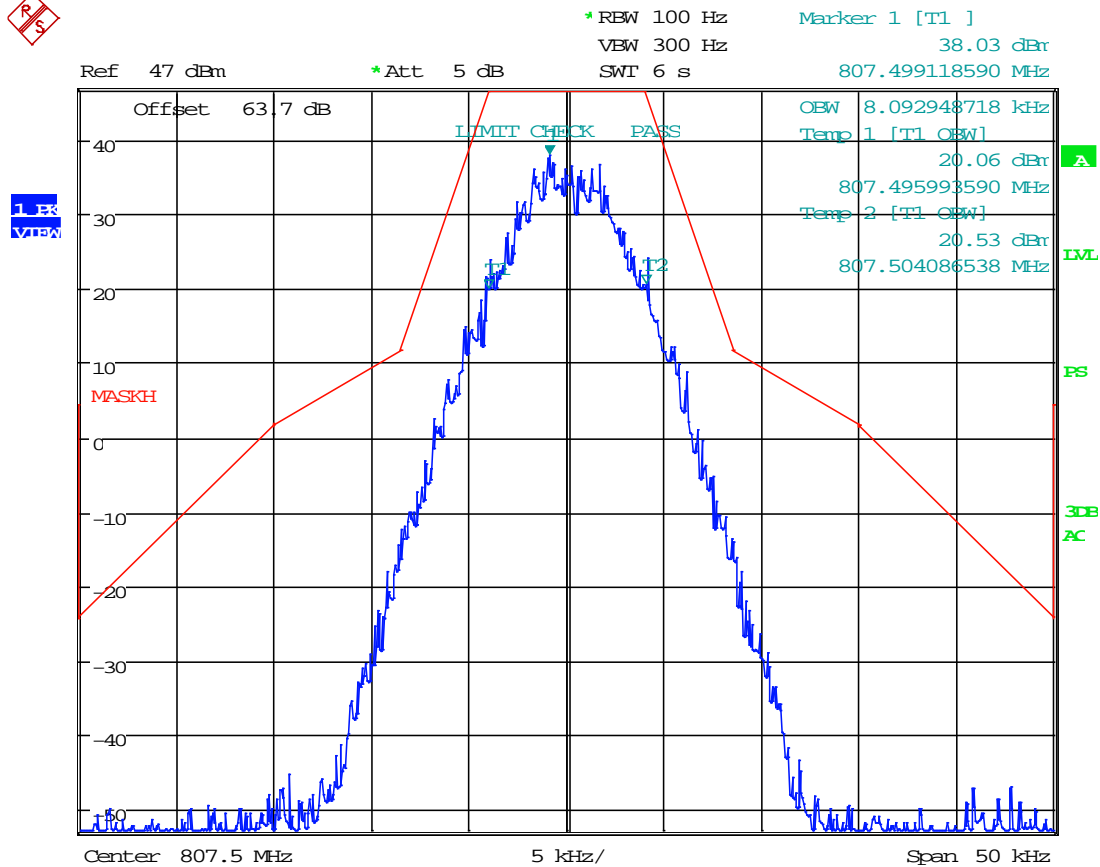

Date: 27.AUG.2019 16:27:13

RESULT: AGC Output Signal 99% OBW = 8.09 kHz

INPUT VS OUTPUT COMPARISON

Test Data: 8K10F1E/F1D Output Signal, @ AGC +14 dBm (Max Input Power)

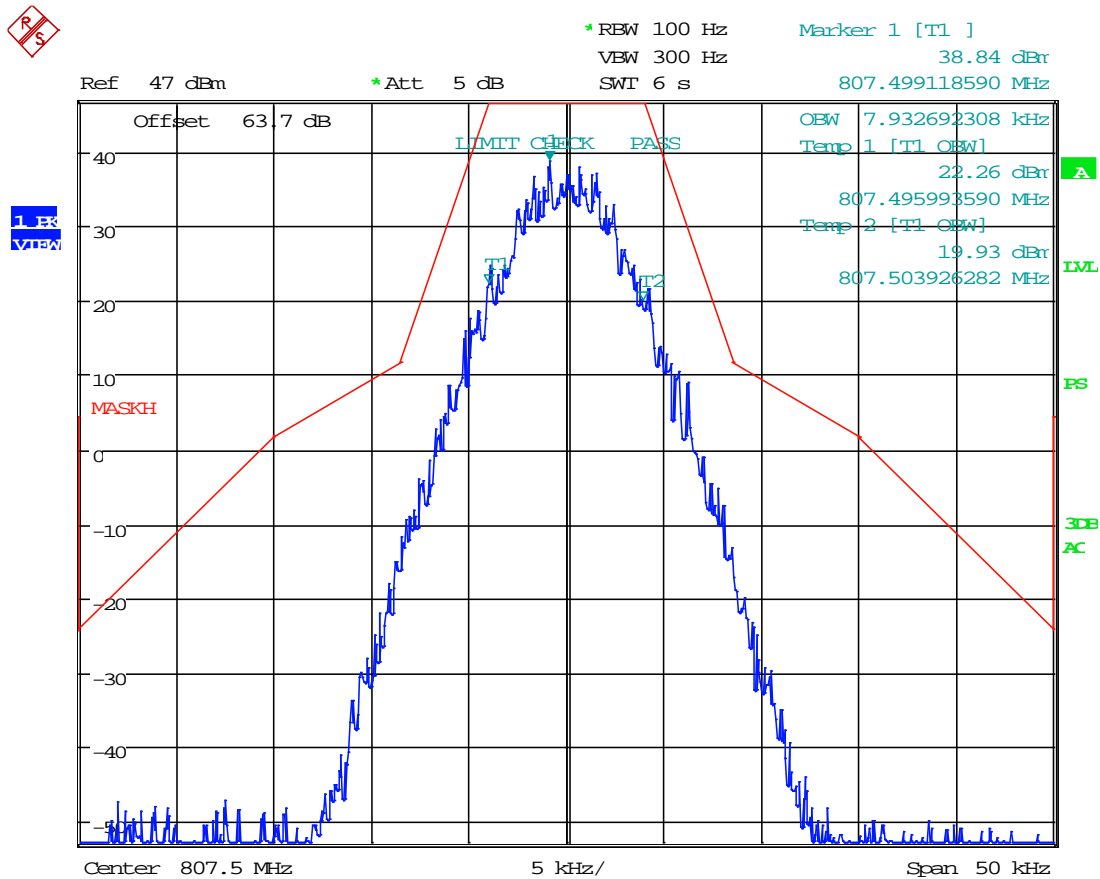

Date: 27.AUG.2019 16:26:25

RESULT: AGC+ 14 Output Signal 99% OBW = 7.93 kHz

INPUT VS OUTPUT COMPARISON

Test Data: 11K3F3E Output Signal, @ AGC

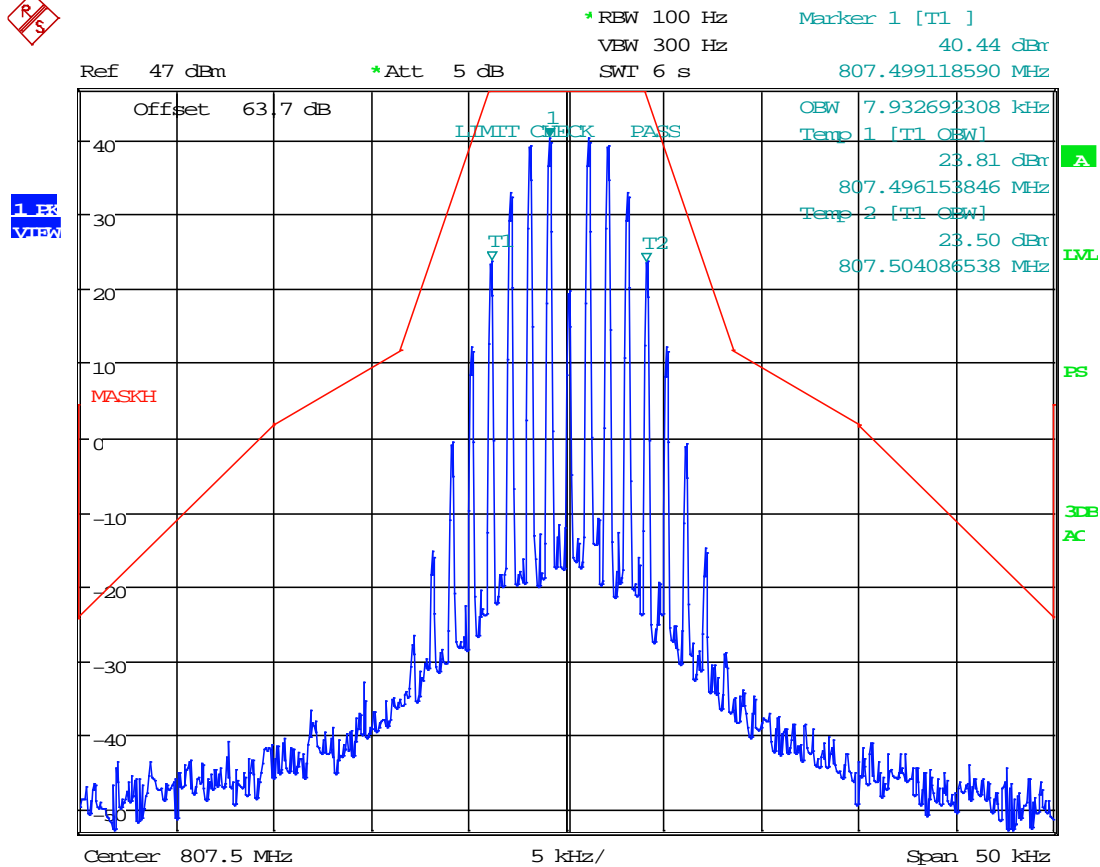

Date: 27.AUG.2019 16:21:14

RESULT: AGC Output Signal 99% OBW = 7.93 kHz

INPUT VS OUTPUT COMPARISON

Test Data: 11K3F3E Output Signal, @ AGC +14 dBm (Max Input Power)

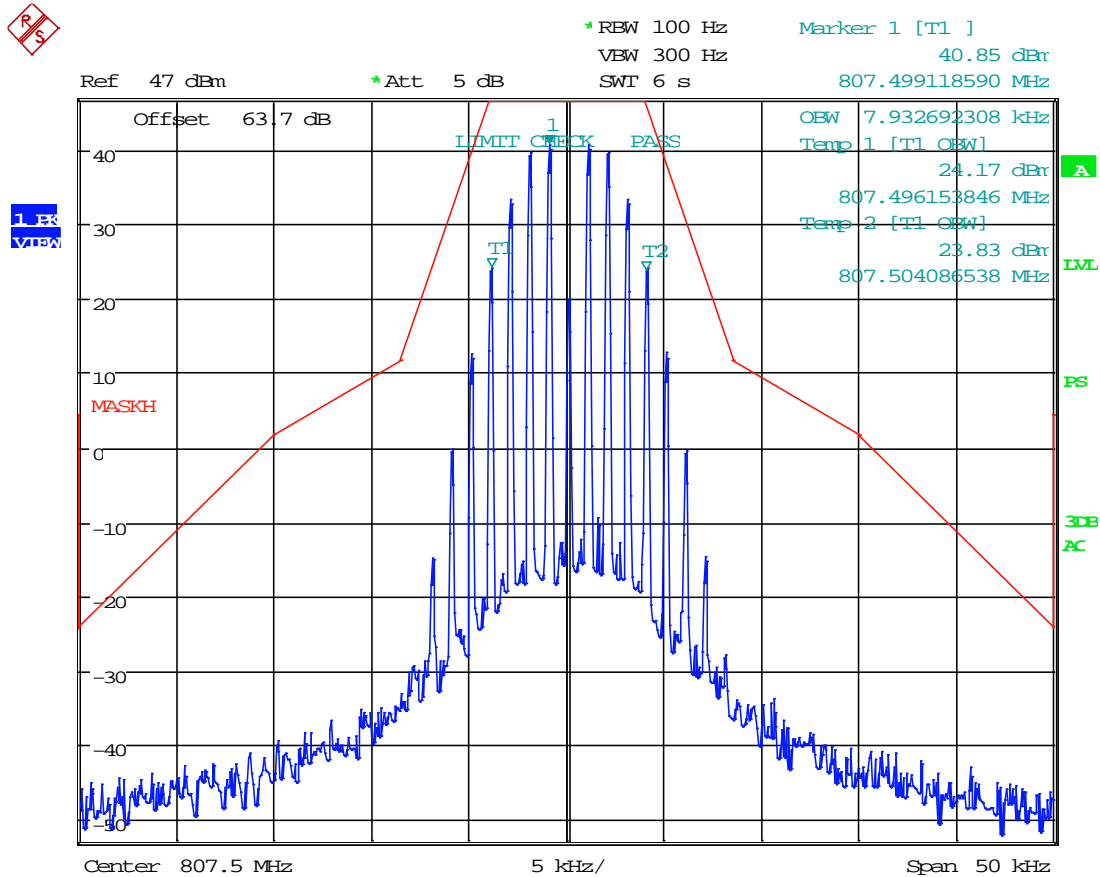

Date: 27.AUG.2019 16:22:12

RESULT: AGC+ 14 Output Signal 99% OBW = 7.93 kHz

INPUT VS OUTPUT COMPARISON

Test Data: 16K0F3E Output Signal, @ AGC

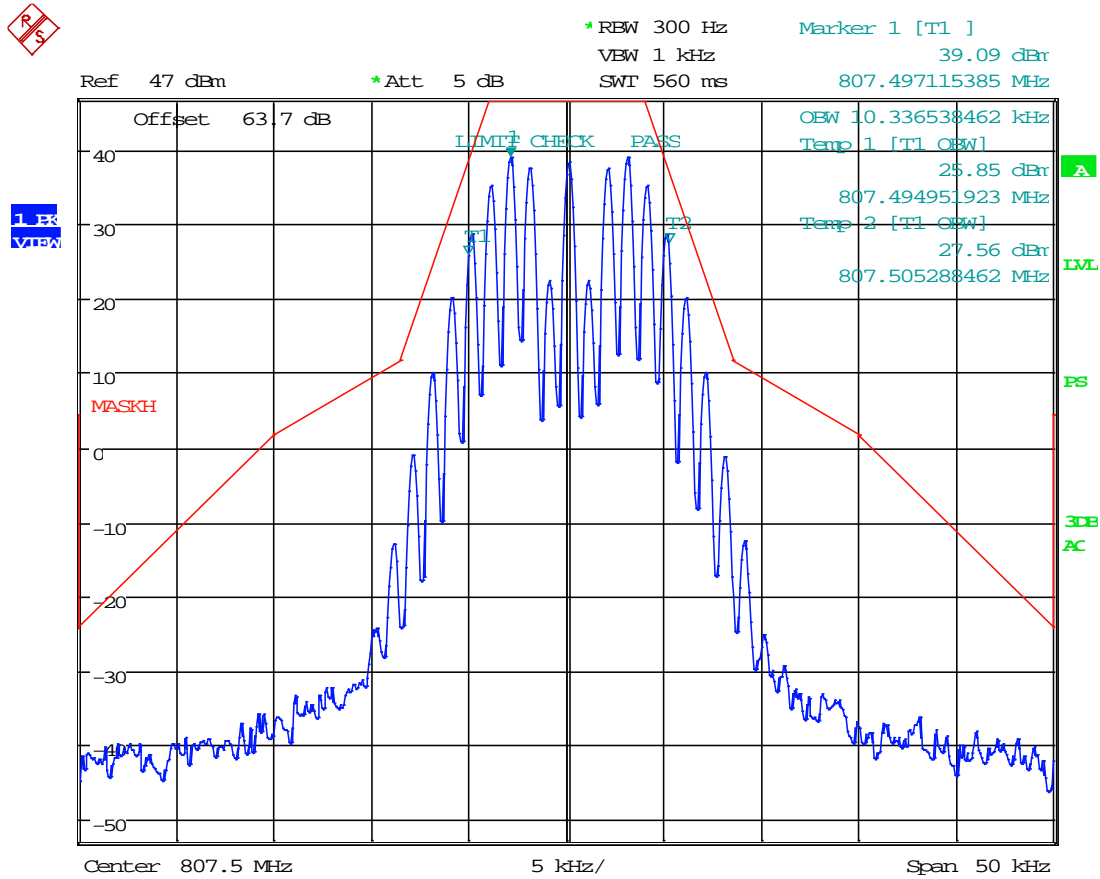

Date: 27.AUG.2019 16:44:13

RESULT: AGC Output Signal 99% OBW = 10.34 kHz

INPUT VS OUTPUT COMPARISON

Test Data: 16K0F3E Output Signal, @ AGC +14 dBm (Max Input Power)

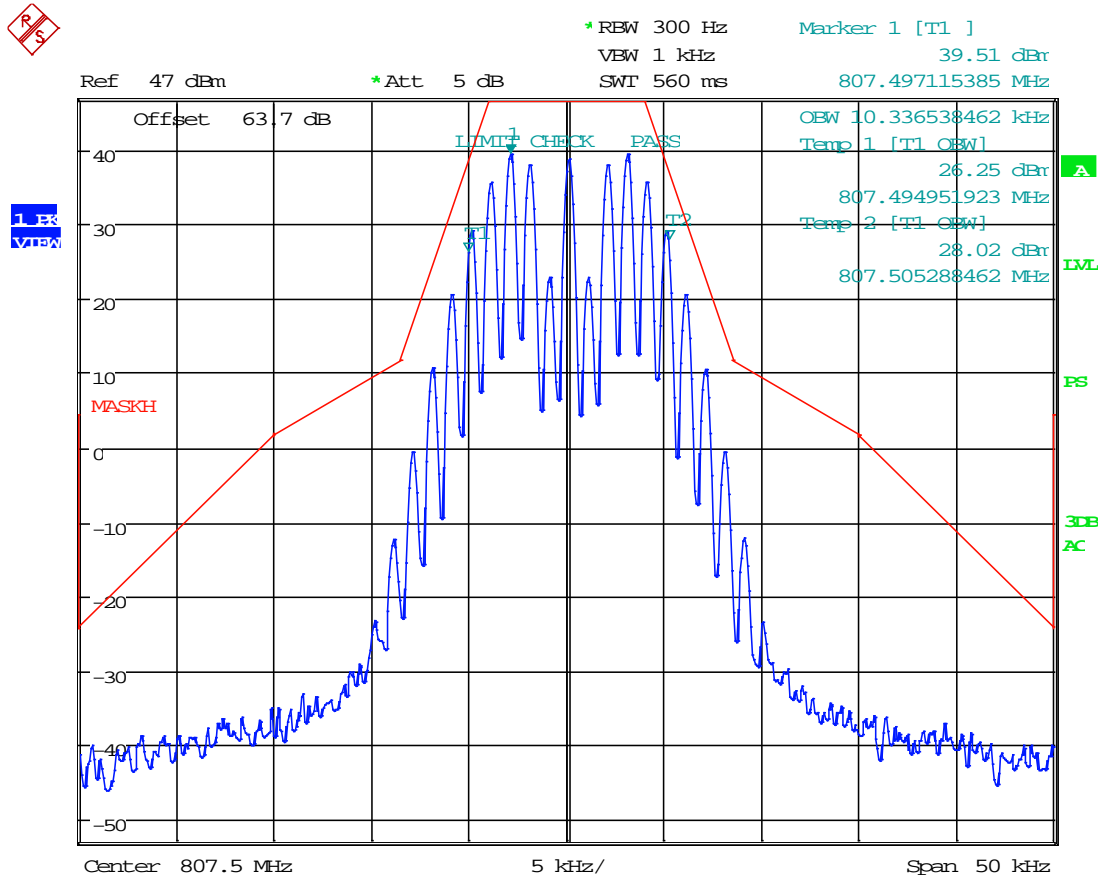

Date: 27.AUG.2019 16:43:27

RESULT: AGC+ 14 Output Signal 99% OBW = 10.34 kHz

INPUT VS OUTPUT COMPARISON

816.5 MHz

Test Data: 4K00F3E Output Signal, @ AGC

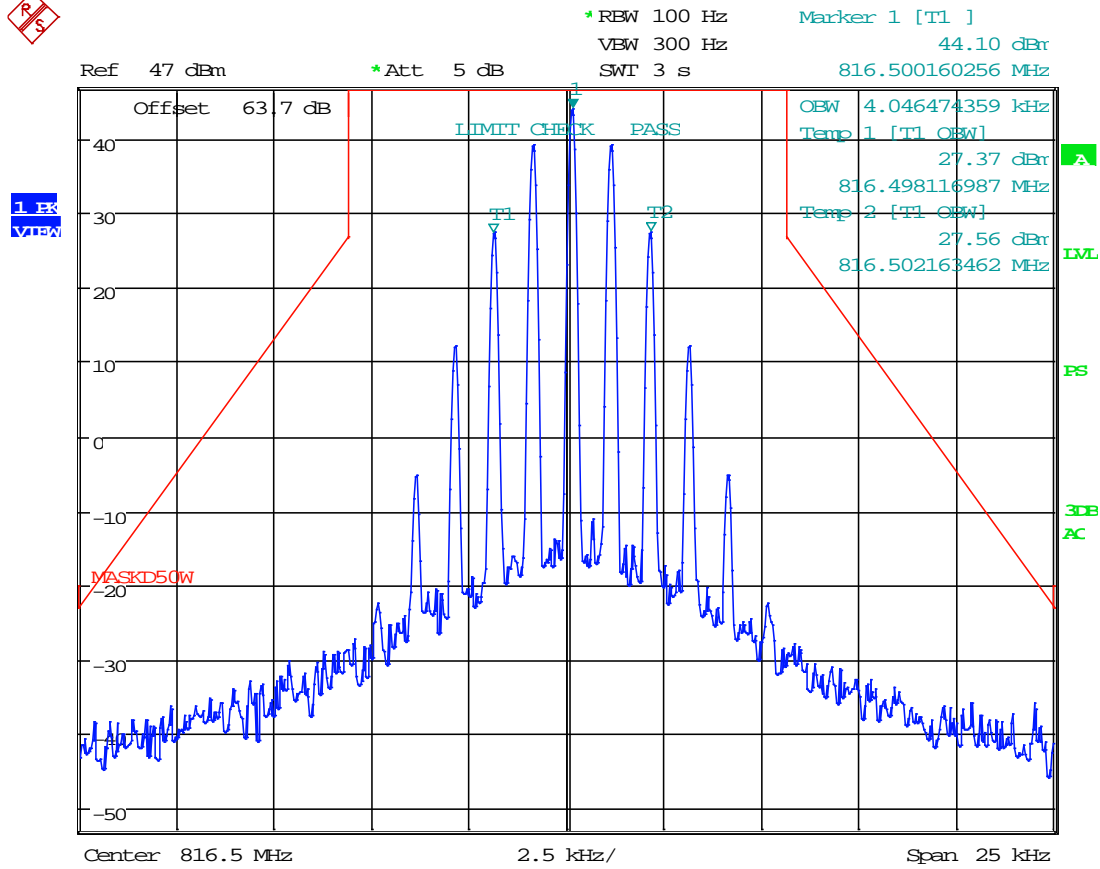

Date: 27.AUG.2019 17:11:30

RESULT: AGC Output Signal 99% OBW = 4.05 kHz

INPUT VS OUTPUT COMPARISON

Test Data: 4K00F3E Output Signal, @ AGC +14 dBm (Max Input Power)

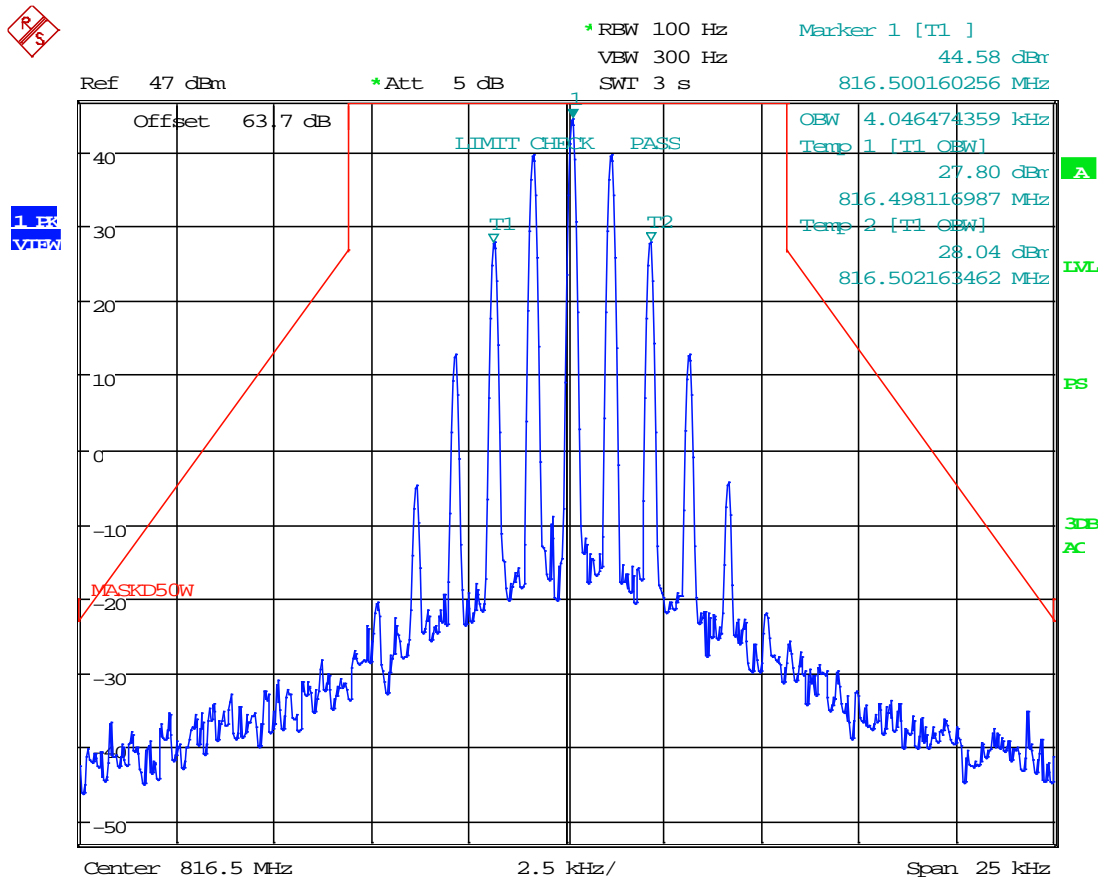

Date: 27.AUG.2019 17:12:41

RESULT: AGC+ 14 Output Signal 99% OBW = 4.05 kHz

INPUT VS OUTPUT COMPARISON

Test Data: 8K10F1E/F1D Output Signal, @ AGC

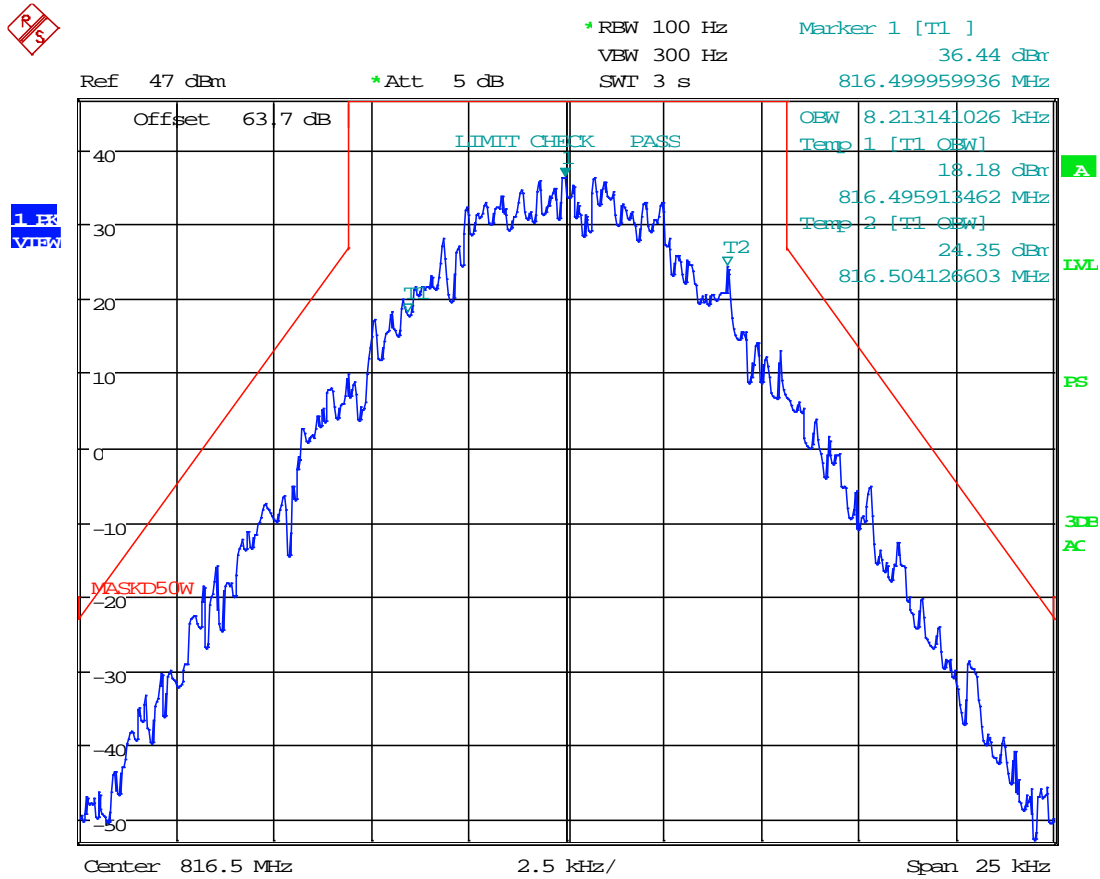

Date: 27.AUG.2019 17:22:41

RESULT: AGC Output Signal 99% OBW = 8.21 kHz

INPUT VS OUTPUT COMPARISON

Test Data: 8K10F1E/F1D Output Signal, @ AGC +14 dBm (Max Input Power)

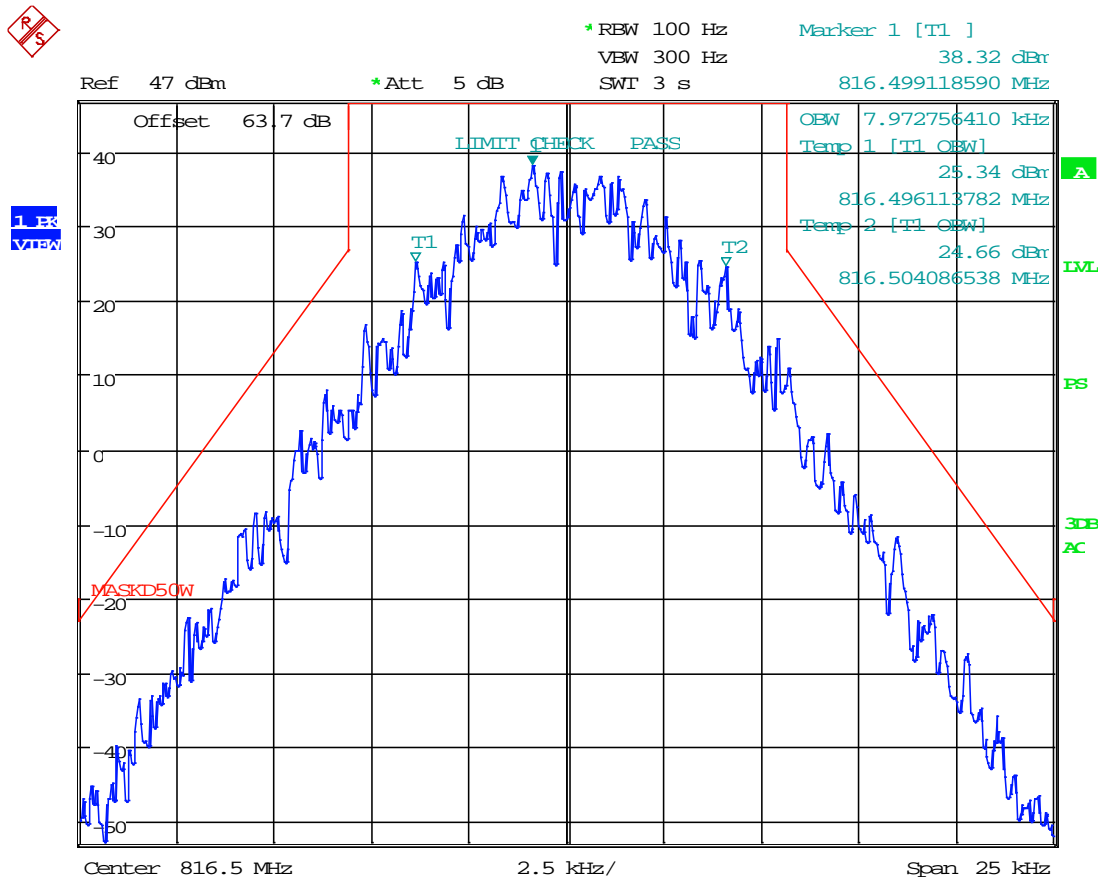

Date: 27.AUG.2019 17:23:38

RESULT: AGC+14 Output Signal 99% OBW = 7.97 kHz

INPUT VS OUTPUT COMPARISON

Test Data: 8K10F1W Output Signal, @ AGC

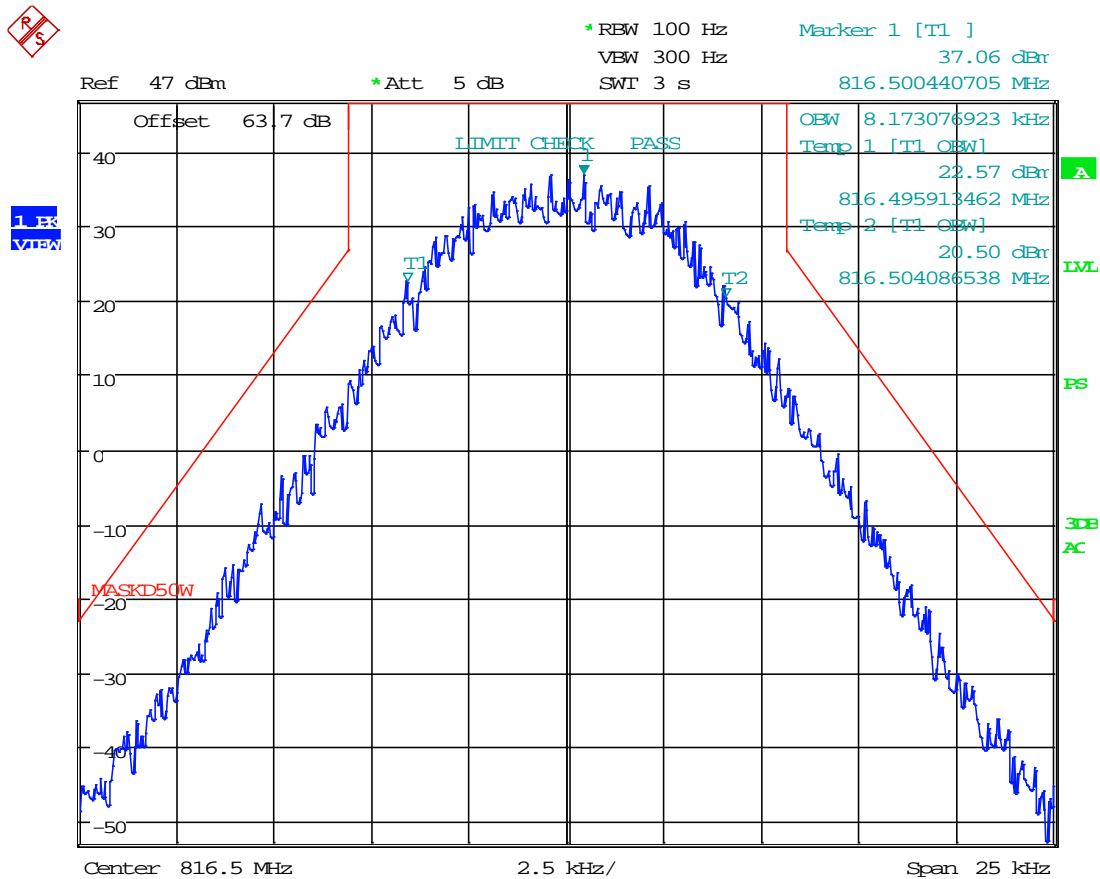

Date: 27.AUG.2019 17:25:25

RESULT: AGC Output Signal 99% OBW = 8.17 kHz

INPUT VS OUTPUT COMPARISON

Test Data: 8K10F1W Output Signal, @ AGC +14 dBm (Max Input Power)

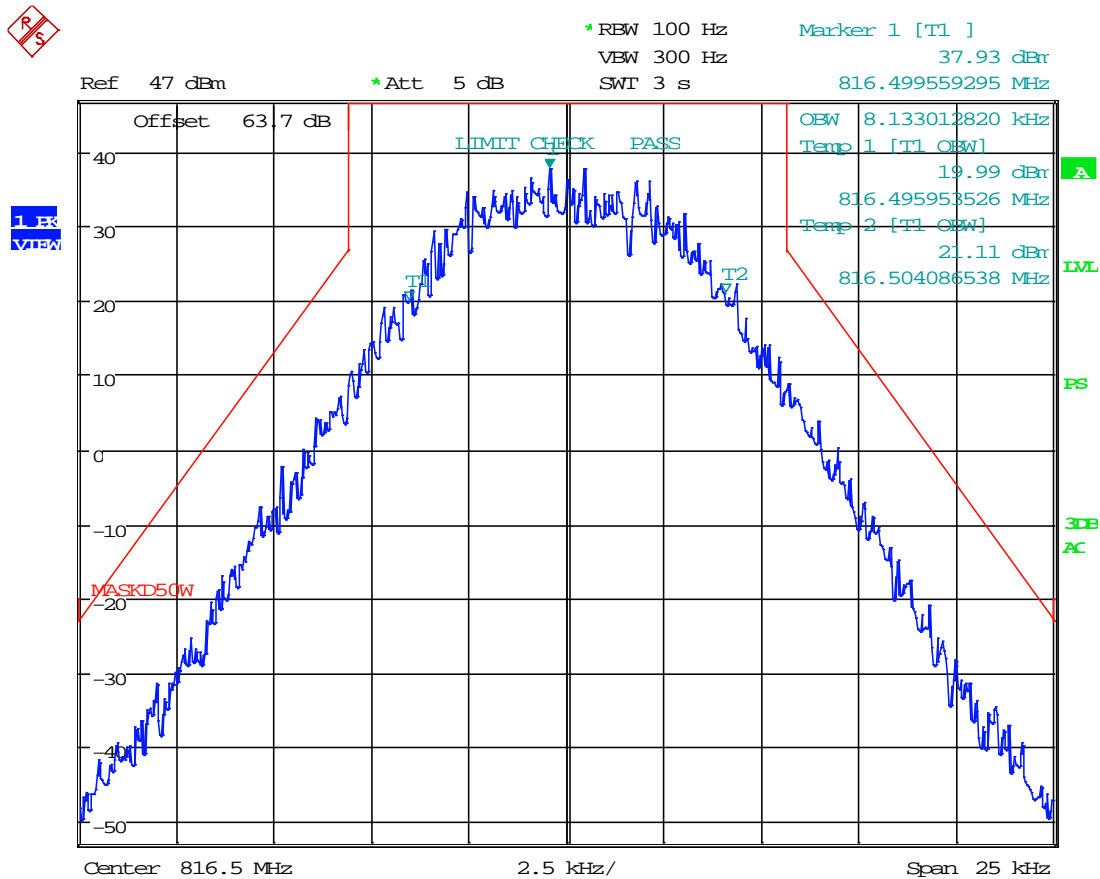

Date: 27.AUG.2019 17:24:41

RESULT: AGC+14 Output Signal 99% OBW = 8.13 kHz

INPUT VS OUTPUT COMPARISON

Test Data: 11K3F3E Output Signal, @ AGC

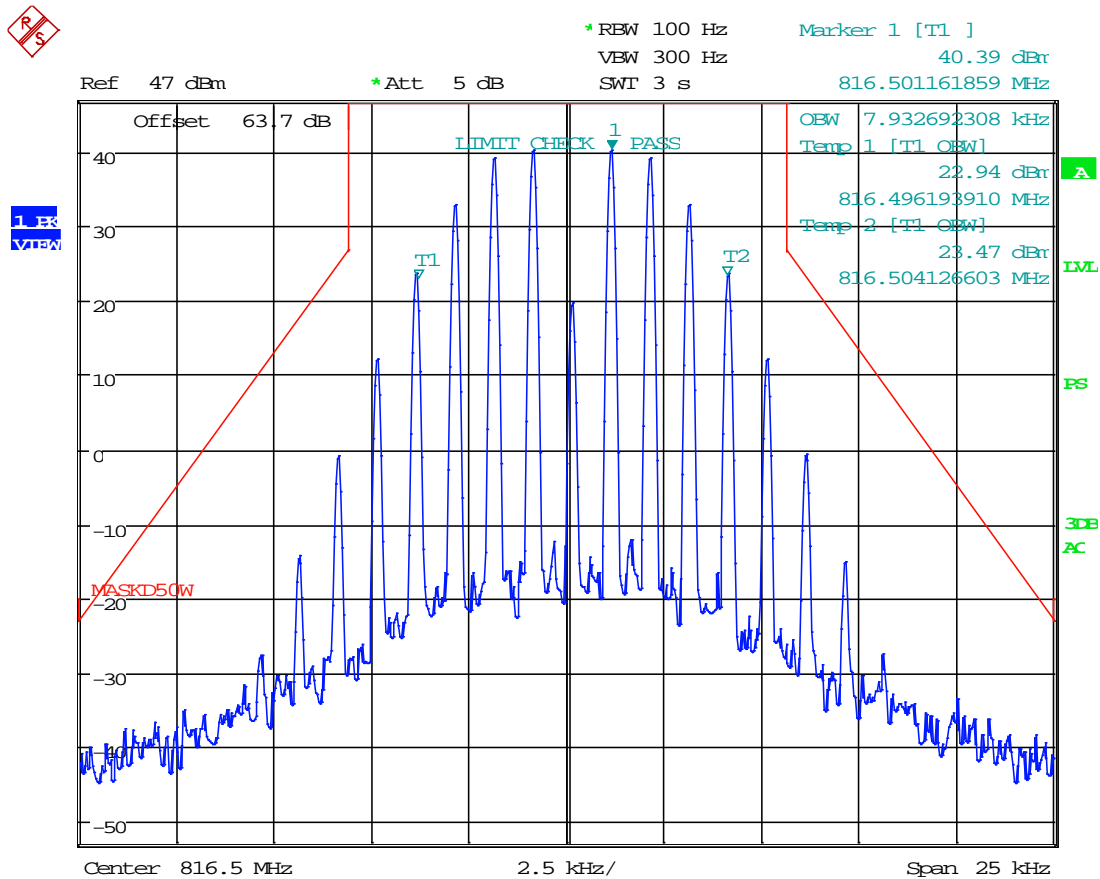

Date: 27.AUG.2019 17:21:15

RESULT: AGC Output Signal 99% OBW = 7.93 kHz

INPUT VS OUTPUT COMPARISON

Test Data: 11K3F3E Output Signal, @ AGC +14 dBm (Max Input Power)

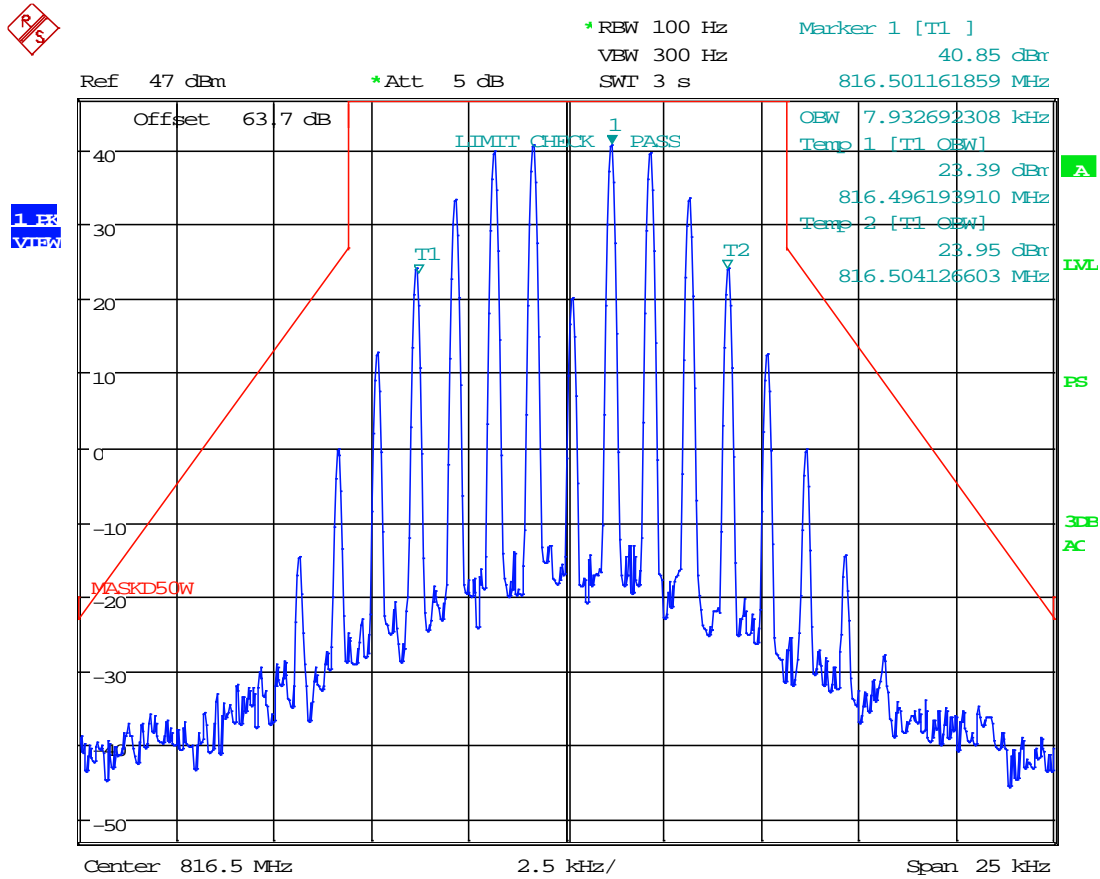

Date: 27.AUG.2019 17:20:21

RESULT: AGC+ 14 Output Signal 99% OBW = 7.93 kHz

INPUT VS OUTPUT COMPARISON

Test Data: 16K0F3E Output Signal, @ AGC

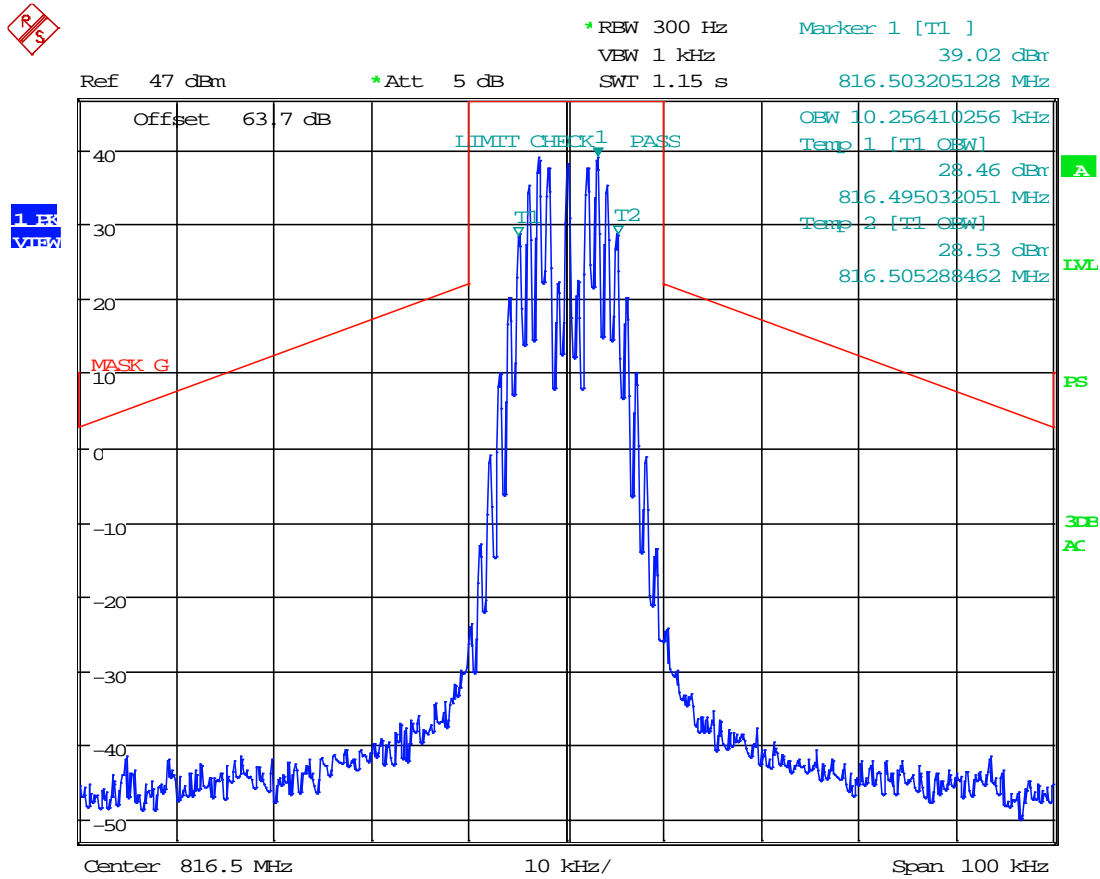

Date: 27.AUG.2019 17:34:41

RESULT: AGC Output Signal 99% OBW = 10.26 kHz

INPUT VS OUTPUT COMPARISON

852.5 MHz

Test Data: 4K00F3E Output Signal, @ AGC

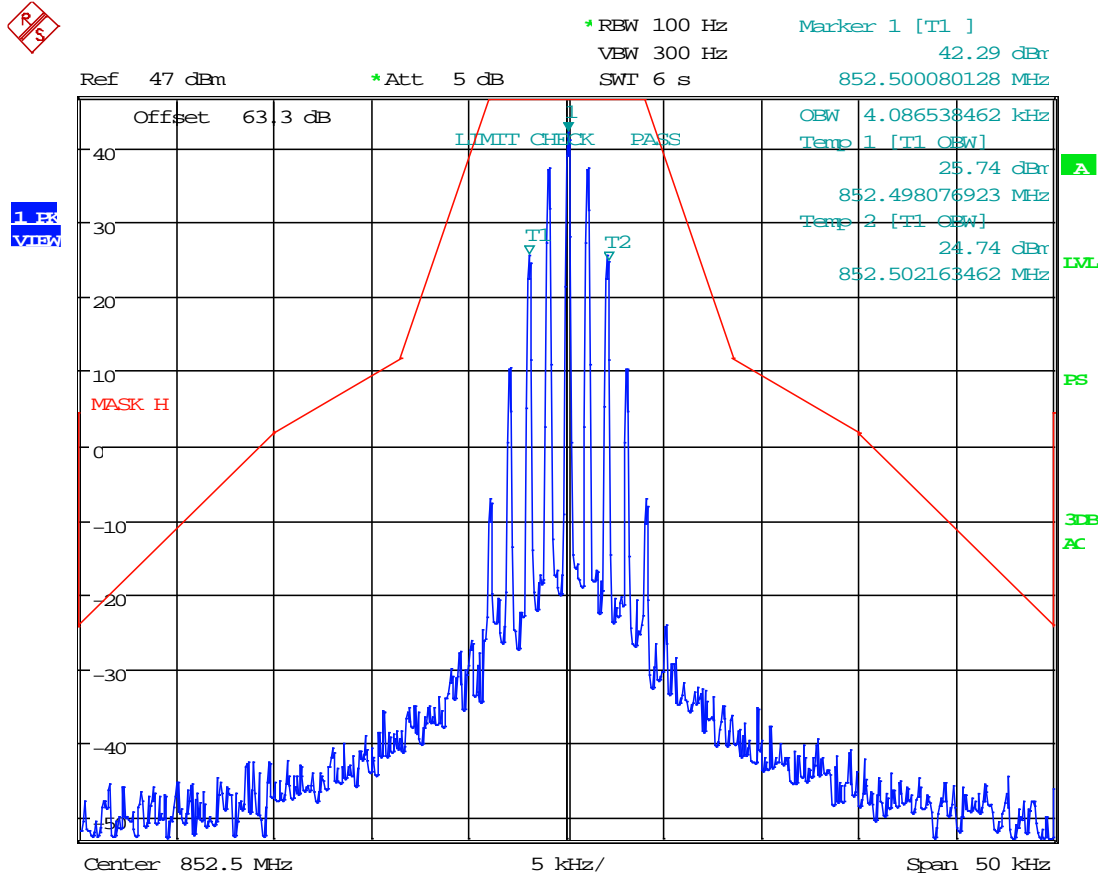

Date: 27.AUG.2019 15:55:55

RESULT: AGC Output Signal 99% OBW = 4.09 kHz

INPUT VS OUTPUT COMPARISON

Test Data: 4K00F3E Output Signal, @ AGC +14 dBm (Max Input Power)

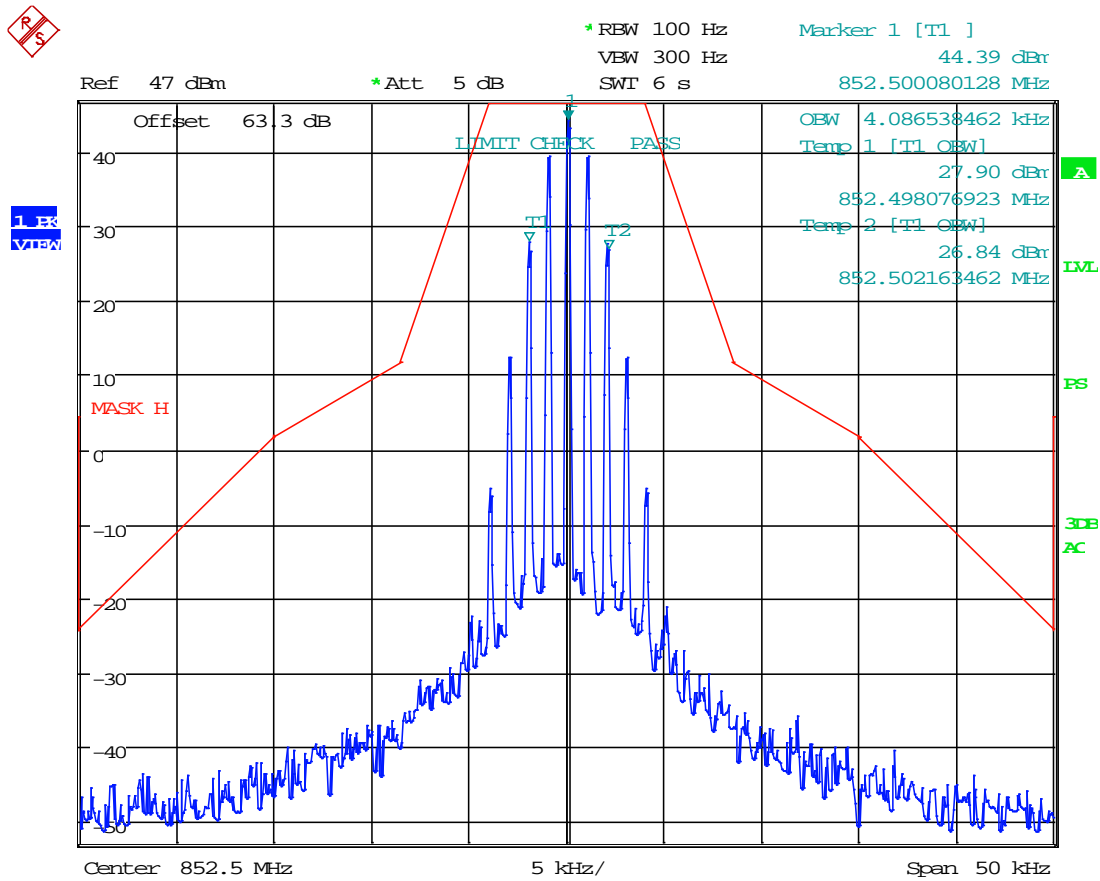

Date: 27.AUG.2019 15:56:44

RESULT: AGC+ 14 Output Signal 99% OBW = 4.09 kHz

INPUT VS OUTPUT COMPARISON

Test Data: 8K10F1E/F1D Output Signal, @ AGC

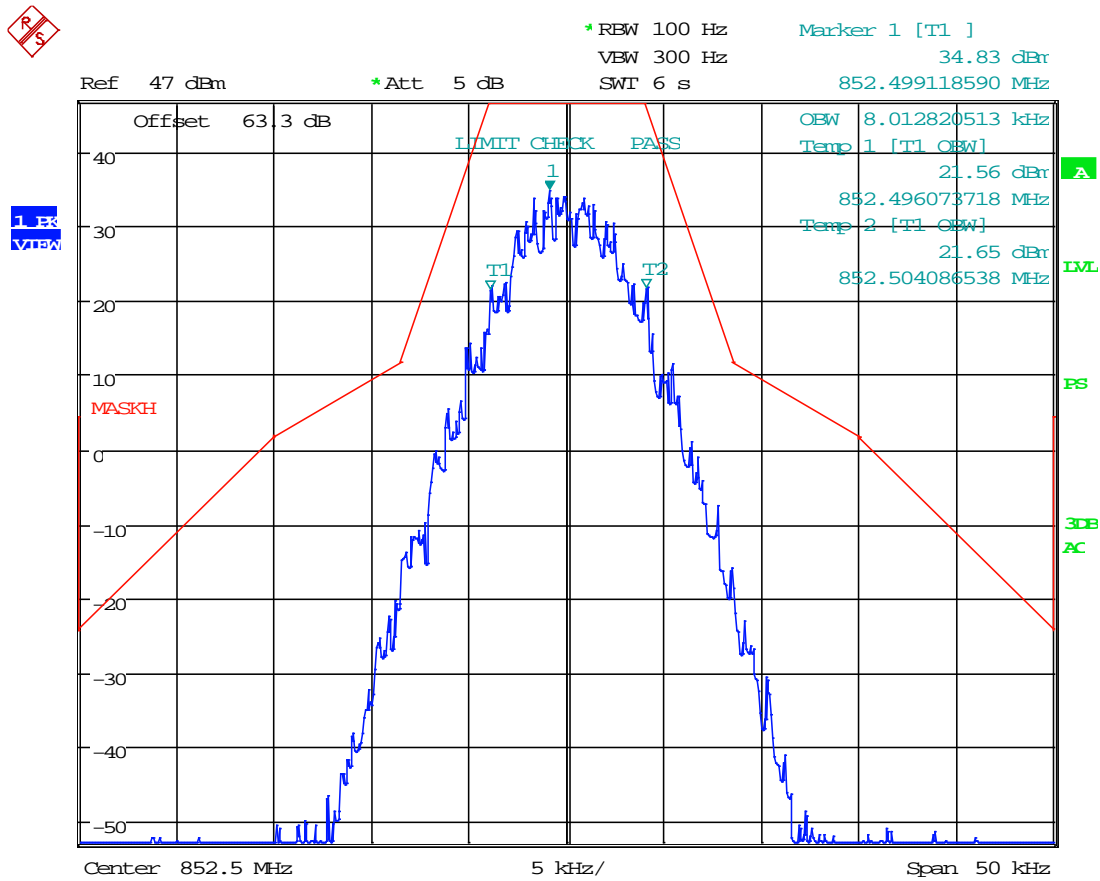

Date: 27.AUG.2019 16:28:50

RESULT: AGC Output Signal 99% OBW = 8.01 kHz

INPUT VS OUTPUT COMPARISON

Test Data: 11K3F3E Output Signal, @ AGC

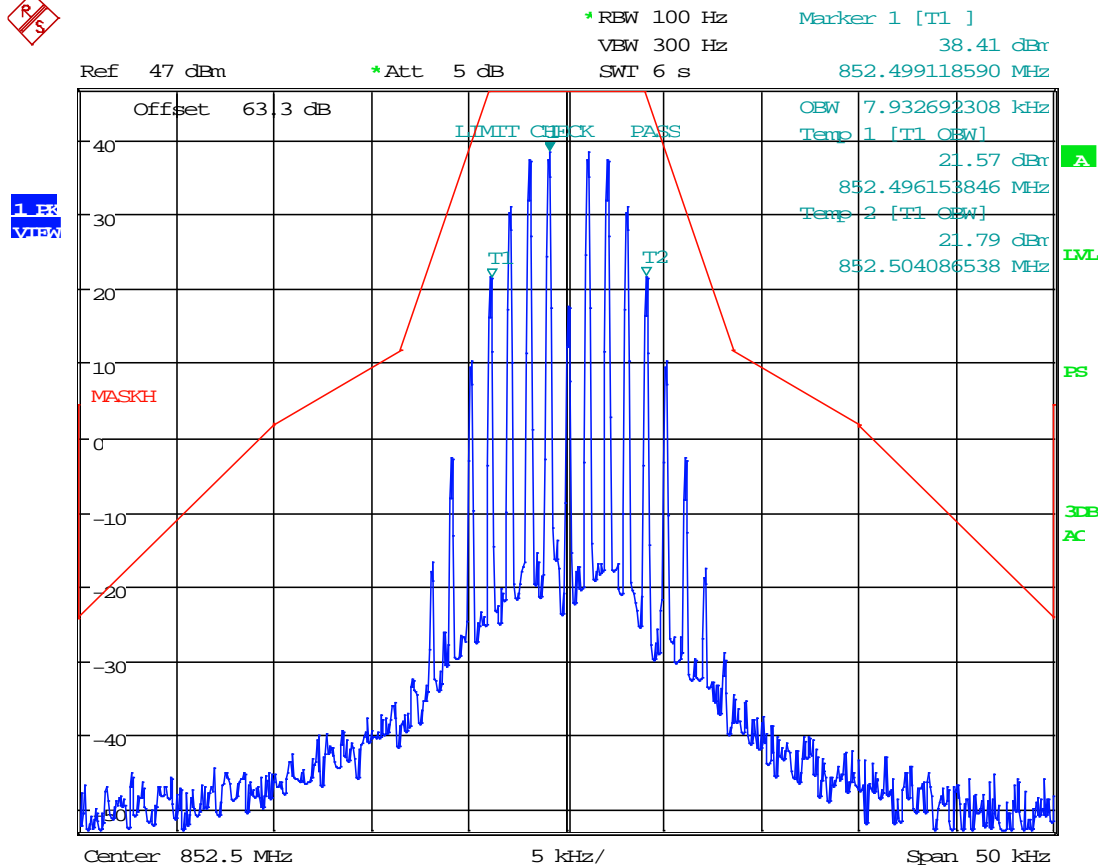

Date: 27.AUG.2019 16:37:36

RESULT: AGC Output Signal 99% OBW = 7.93 kHz

INPUT VS OUTPUT COMPARISON

Test Data: 11K3F3E Output Signal, @ AGC +14 dBm (Max Input Power)

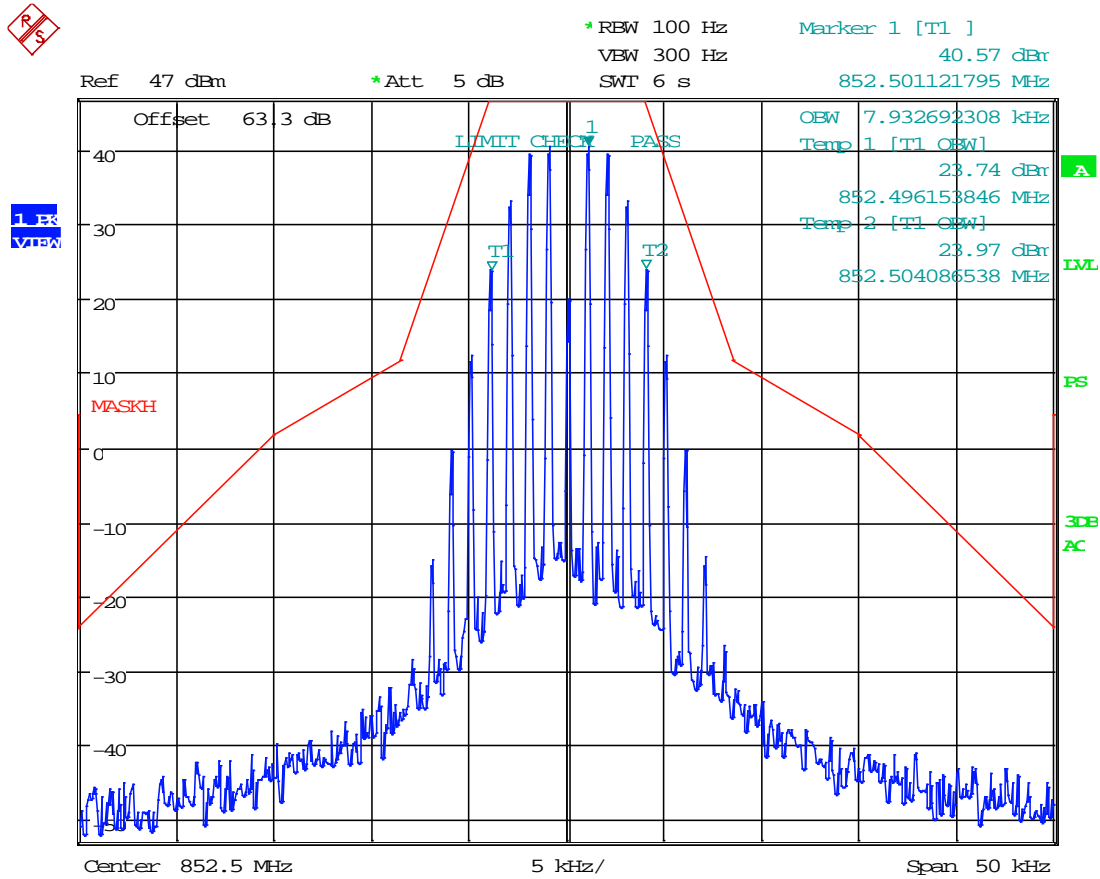

Date: 27.AUG.2019 16:36:46

RESULT: AGC+ 14 Output Signal 99% OBW = 7.93 kHz

INPUT VS OUTPUT COMPARISON

Test Data: 16K0F3E Output Signal, @ AGC

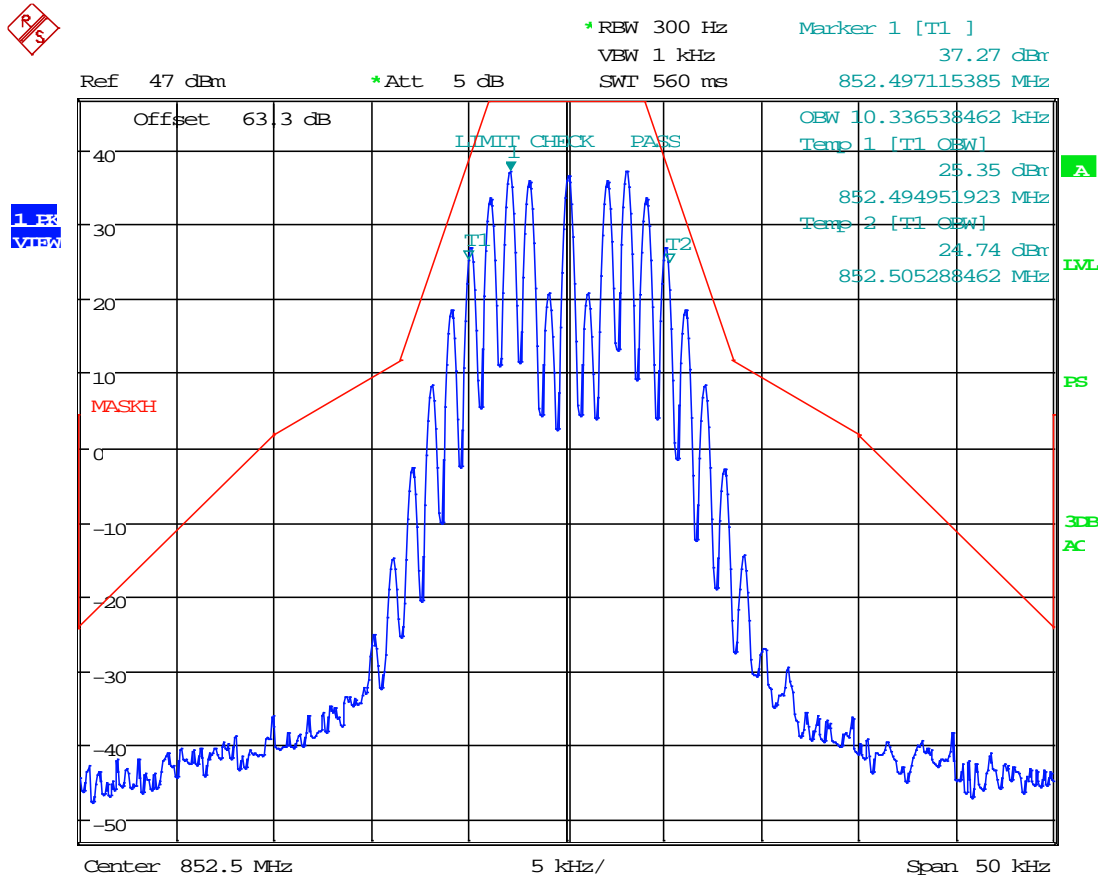

Date: 27.AUG.2019 16:41:50

RESULT: AGC Output Signal 99% OBW = 10.34 kHz

INPUT VS OUTPUT COMPARISON

Test Data: 16K0F3E Output Signal, @ AGC +14 dBm (Max Input Power)

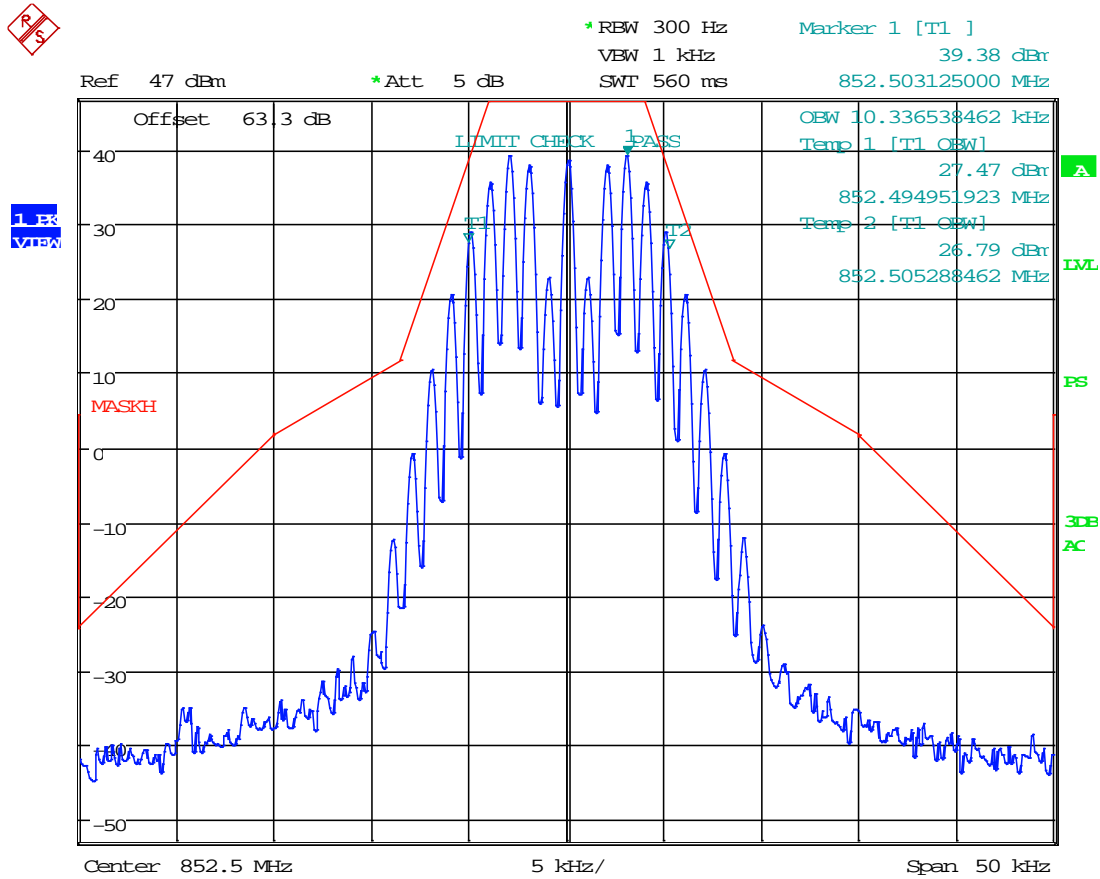

Date: 27.AUG.2019 16:42:29

RESULT: AGC+ 14 Output Signal 99% OBW = 10.34 kHz

INPUT VS OUTPUT COMPARISON

861.5 MHz

Test Data: 4K00F3E Output Signal, @ AGC

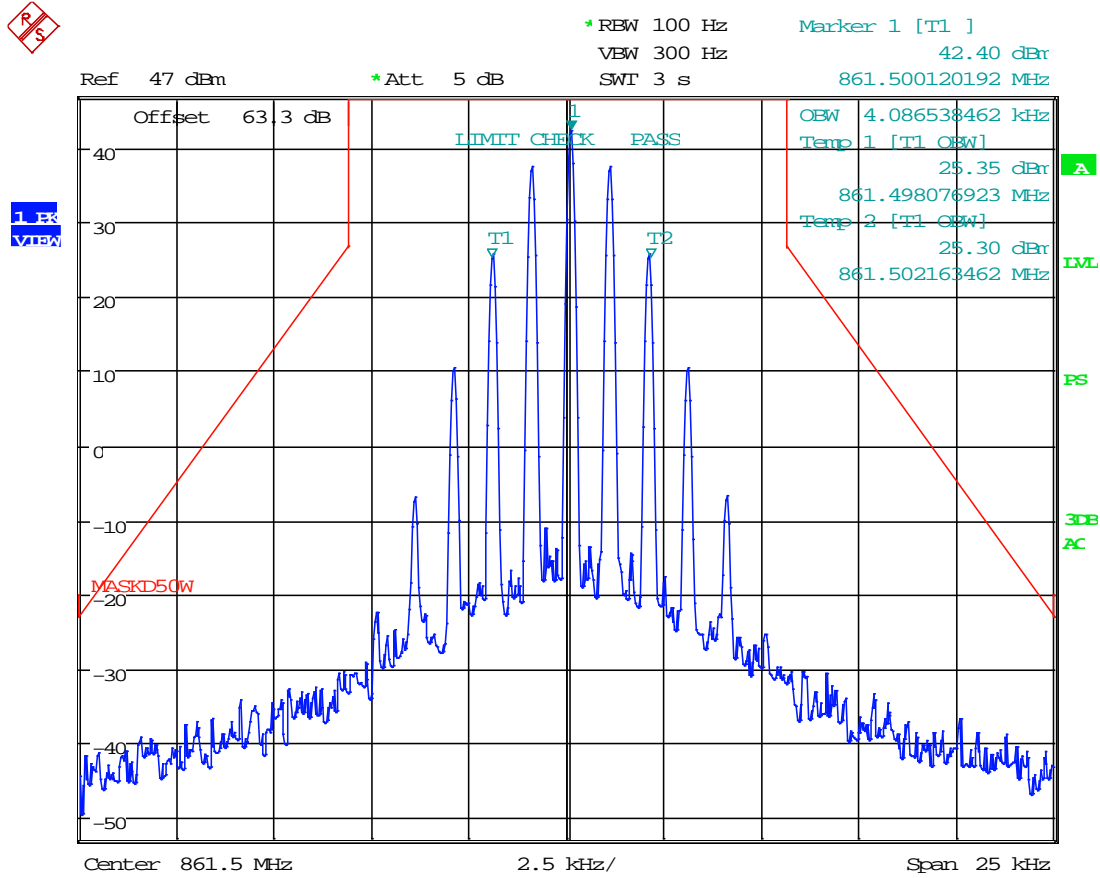

Date: 27.AUG.2019 17:15:20

RESULT: AGC Output Signal 99% OBW = 4.09 kHz

INPUT VS OUTPUT COMPARISON

Test Data: 4K00F3E Output Signal, @ AGC +14 dBm (Max Input Power)

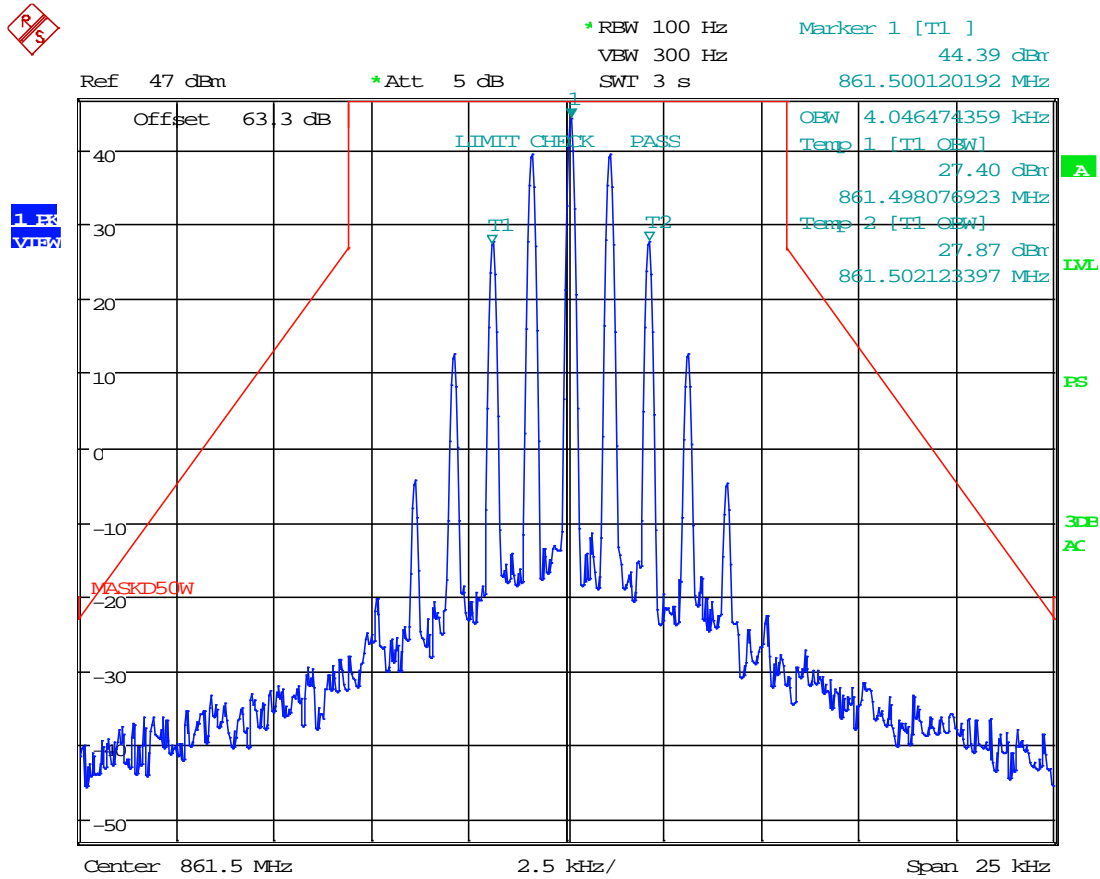

Date: 27.AUG.2019 17:14:08

RESULT: AGC+ 14 Output Signal 99% OBW = 4.05 kHz

INPUT VS OUTPUT COMPARISON

Test Data: 8K10F1E/F1D Output Signal, @ AGC

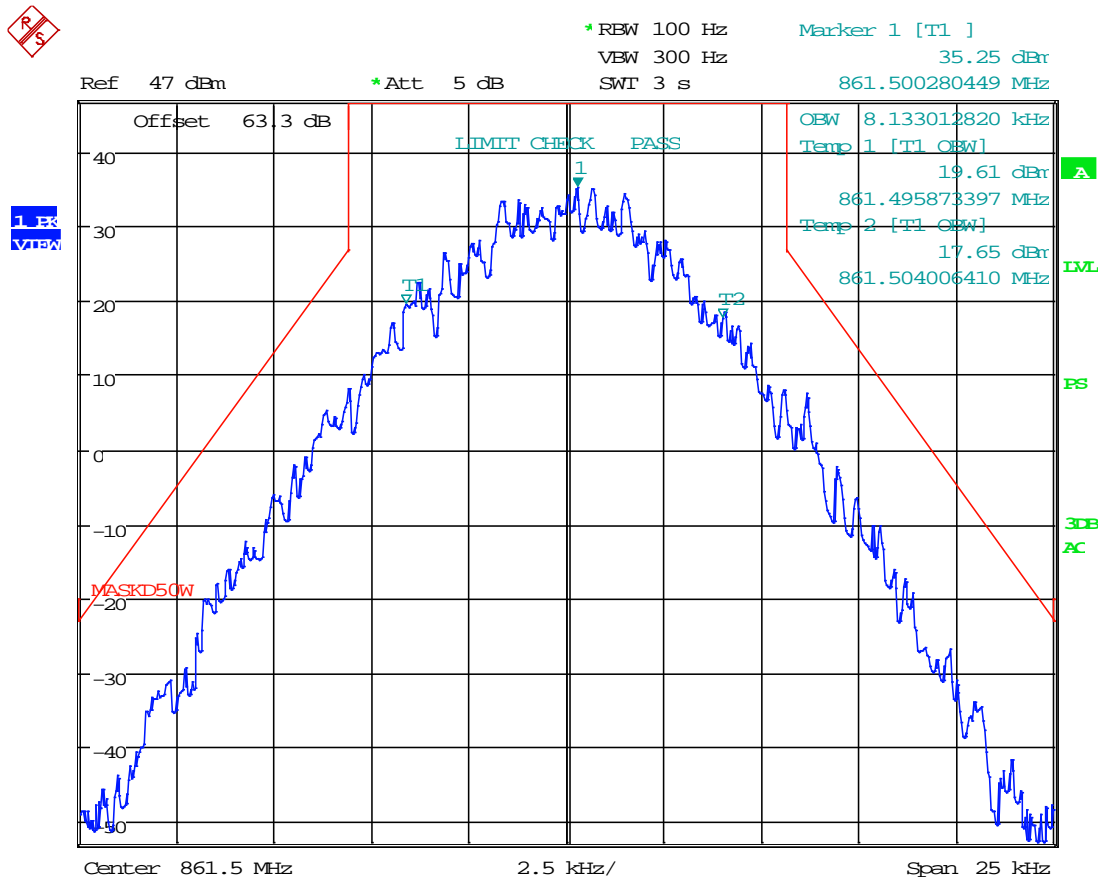

Date: 27.AUG.2019 17:29:16

RESULT: AGC Output Signal 99% OBW = 8.13 kHz

INPUT VS OUTPUT COMPARISON

Test Data: 8K10F1E/F1D Output Signal, @ AGC +14 dBm (Max Input Power)

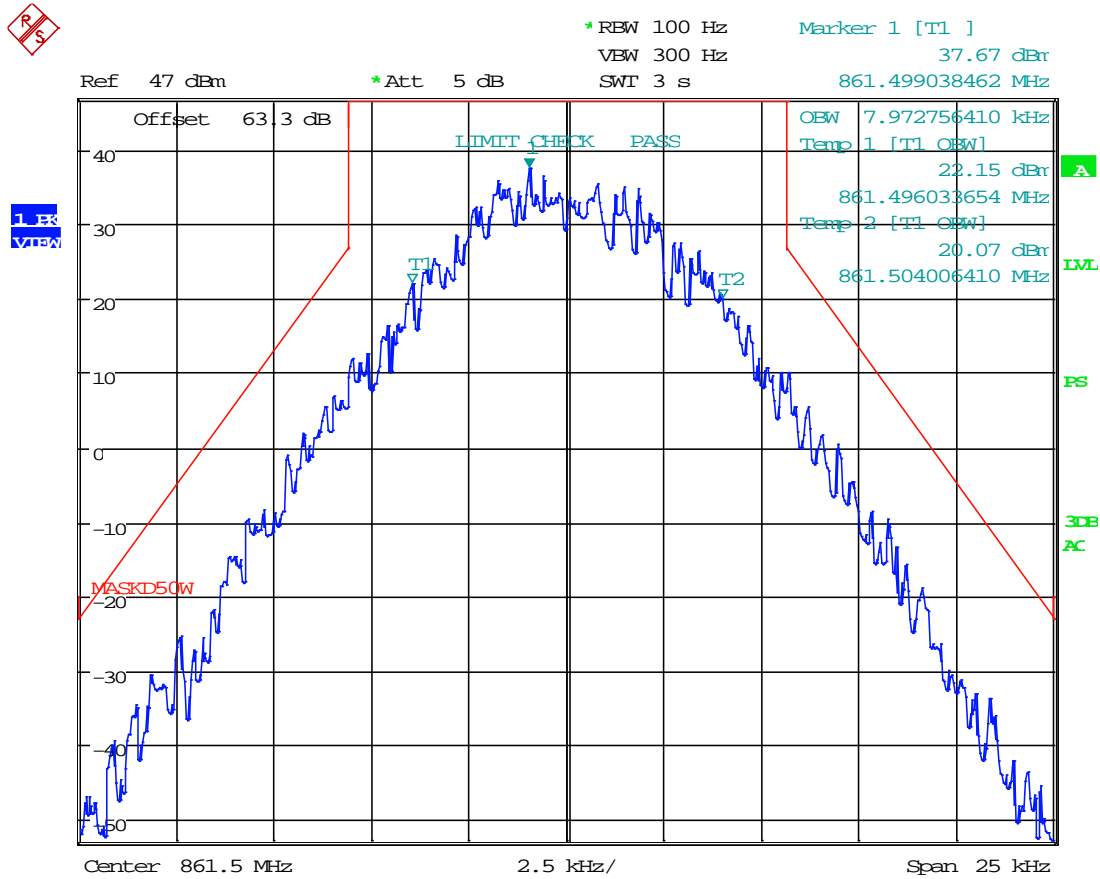

Date: 27.AUG.2019 17:28:26

RESULT: AGC+14 Output Signal 99% OBW = 7.97 kHz

INPUT VS OUTPUT COMPARISON

Test Data: 8K10F1W Output Signal, @ AGC +14 dBm (Max Input Power)

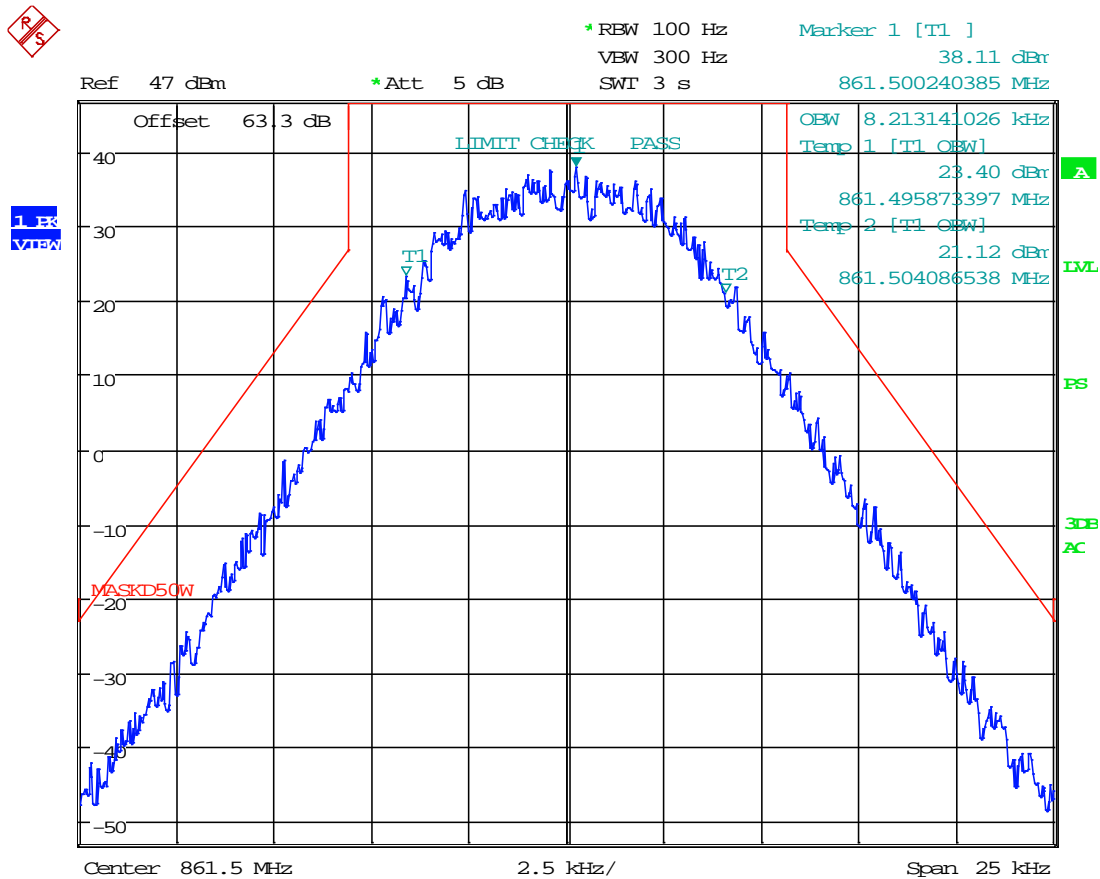

Date: 27.AUG.2019 17:27:31

RESULT: AGC+14 Output Signal 99% OBW = 8.21 kHz

INPUT VS OUTPUT COMPARISON

Test Data: 11K3F3E Output Signal, @ AGC

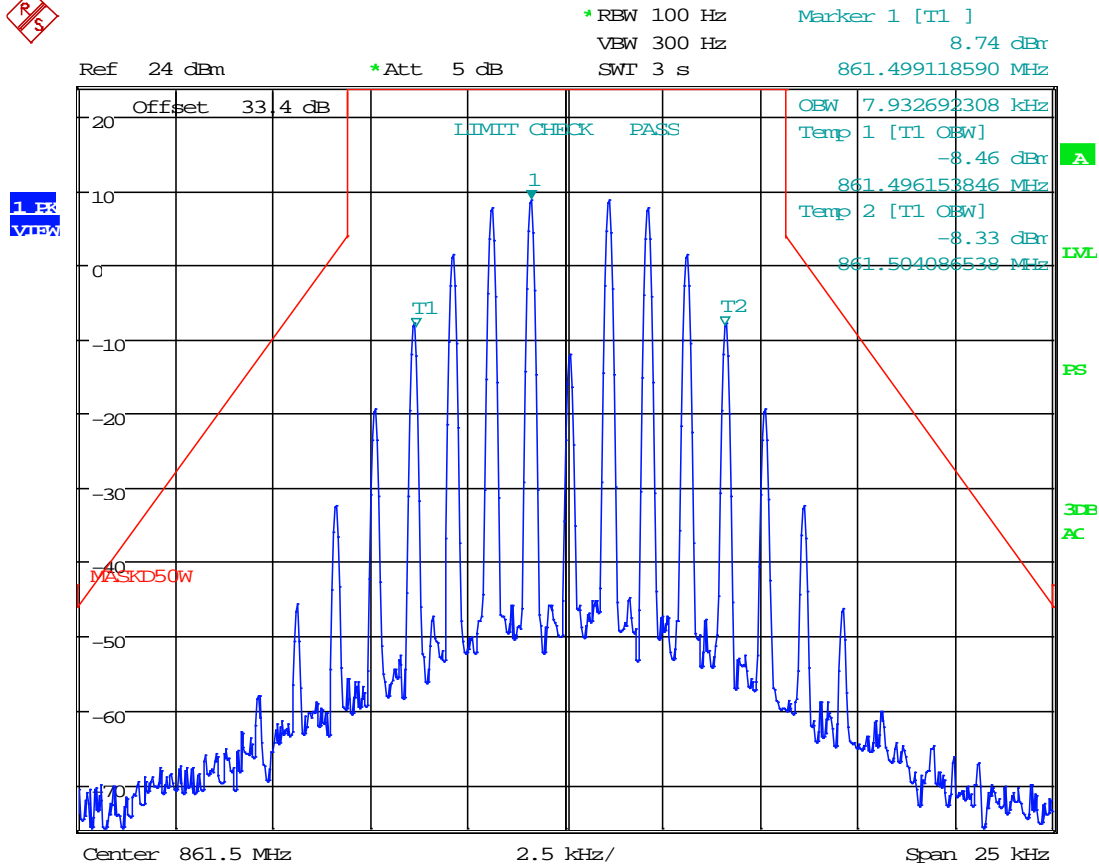

Date: 27.AUG.2019 17:17:34

RESULT: AGC Output Signal 99% OBW = 7.93 kHz

INPUT VS OUTPUT COMPARISON

Test Data: 11K3F3E Output Signal, @ AGC +14 dBm (Max Input Power)

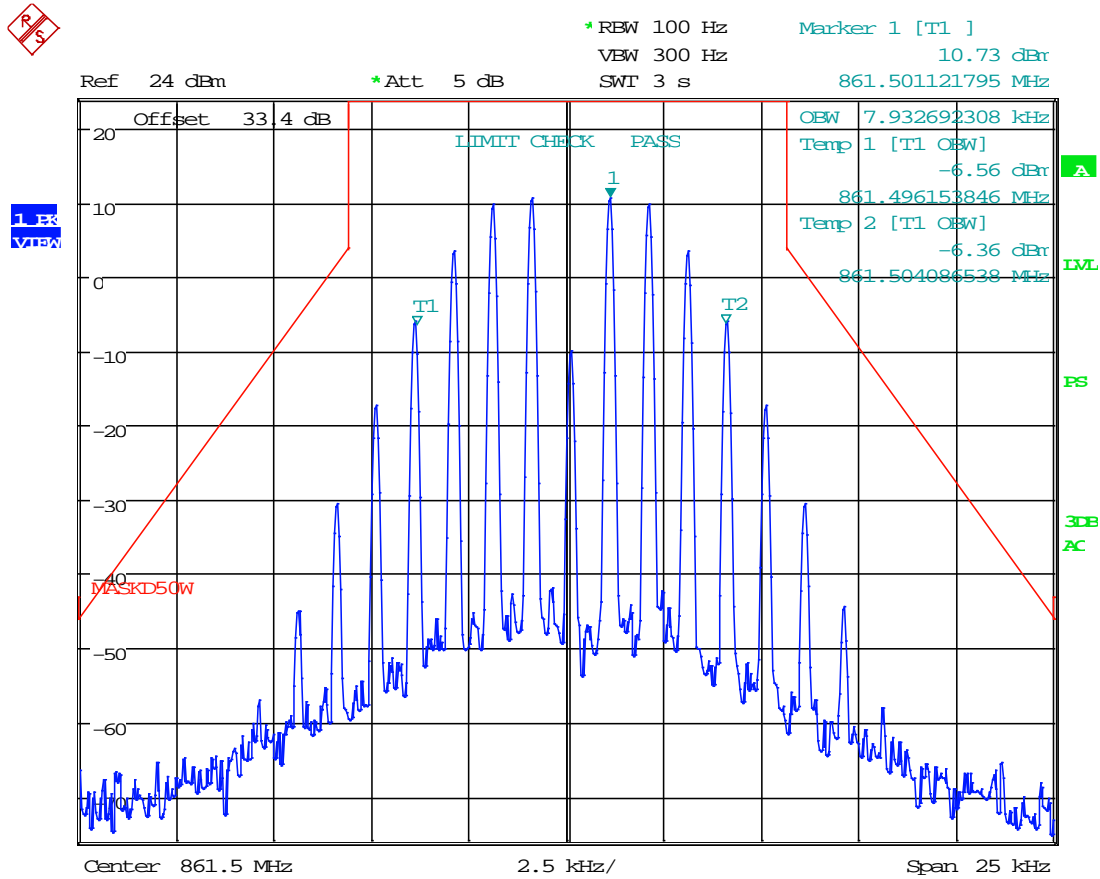

Date: 27.AUG.2019 17:18:13

RESULT: AGC+ 14 Output Signal 99% OBW = 7.93 kHz

INPUT VS OUTPUT COMPARISON

Test Data: 16K0F3E Output Signal, @ AGC

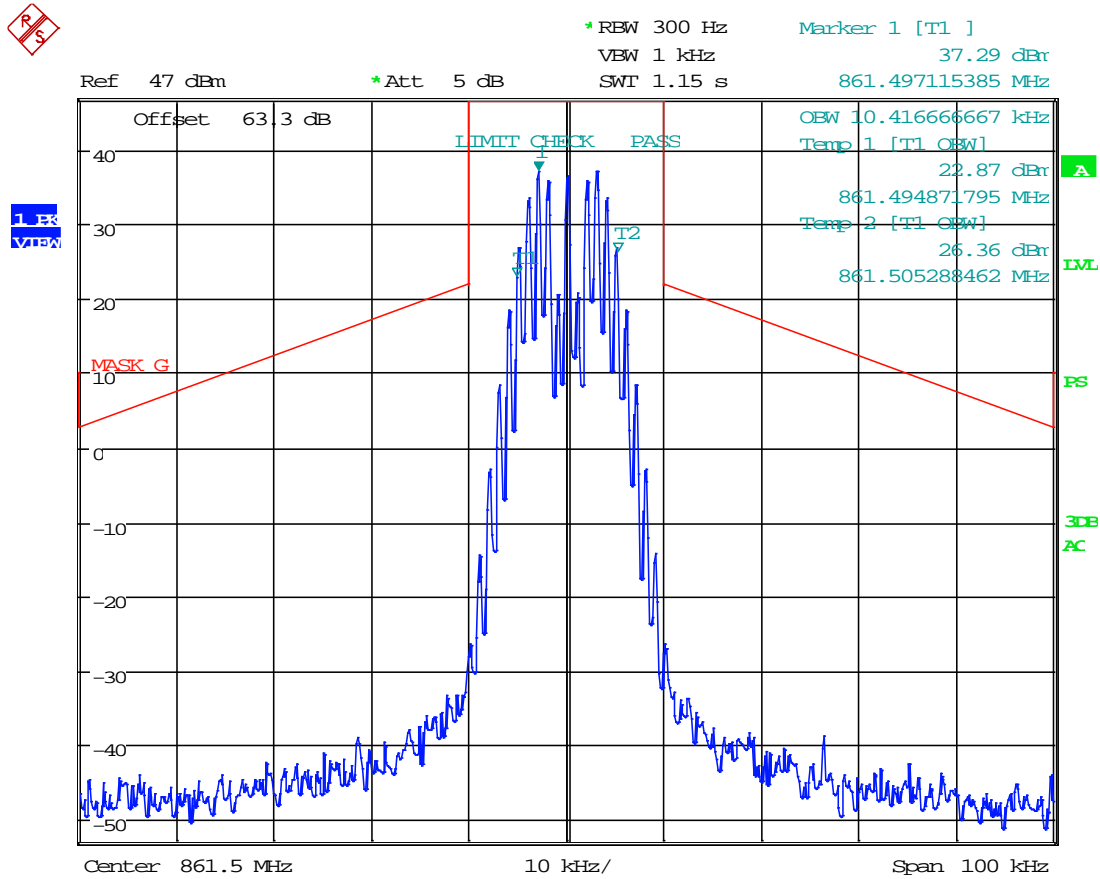

Date: 27.AUG.2019 17:32:17

RESULT: AGC Output Signal 99% OBW = 10.42 kHz

INPUT VS OUTPUT COMPARISON

Test Data: 16K0F3E Output Signal, @ AGC +14 dBm (Max Input Power)

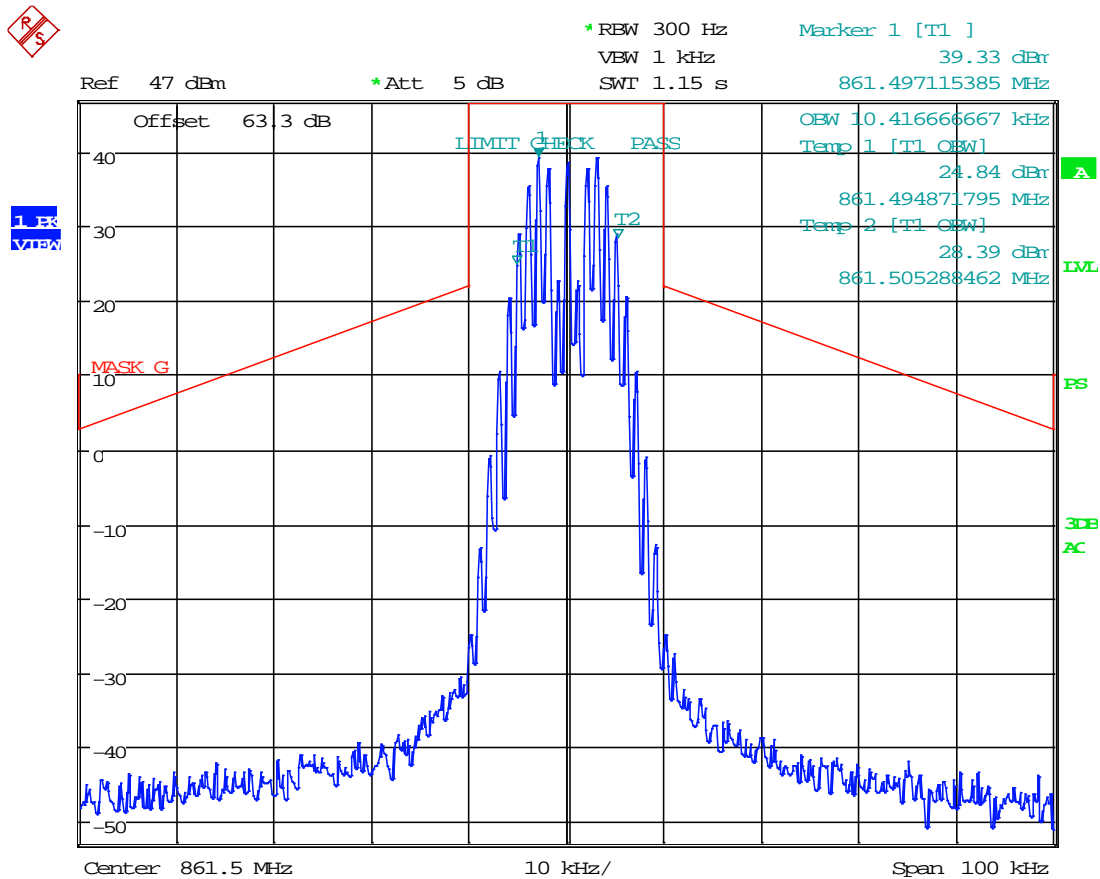

Date: 27.AUG.2019 17:33:03

RESULT: AGC+ 14 Output Signal 99% OBW = 10.42 kHz

ADJACENT CHANNEL POWER

Rule Part No.: KDB 935210 s.4.4, FCC Pt. 2.1049(h), FCC Pt. 90.543(a),(c),(e)

Compliance with the emission mask of the EUT output shall be measured for the public safety service signal types as specified in 4.1.

Refer to the applicable regulatory requirements (e.g., Section 90.210) for emission mask specifications.

Requirements: Part 90.453(a)

§90.543 Emission limitations.

Transmitters designed to operate in 769-775 MHz and 799-805 MHz frequency bands must meet the emission limitations in paragraphs (a) through (d) of this section. Class A and Class B signal boosters retransmitting signals in the 769-775 MHz and 799-805 MHz frequency bands are exempt from the limits listed in paragraph (a) of this section when simultaneously retransmitting multiple signals and instead shall be subject to the limit listed in paragraph (c) of this section when operating in this manner. Transmitters operating in 758-768 MHz and 788-798 MHz bands must meet the emission limitations in (e) of this section.

Test Data: n/a

Per Part 90.543, the device shall meet 90.543(c), equivalent to the requirement which is already in place for this EUT in 90.219(e)(3).

RF POWER OUTPUT

Rule Part No.: KDB 935210 s.4.5, 4.5.5, FCC Pt. 2.1046(a), FCC Pt. 2.1033(c)(8), FCC Pt. 90.219(d)(3), FCC Pt. 90.219(e)(1), FCC Pt. 90.219(e)(4)(iii)

Requirements:

(d) *Deployment rules.* Deployment of signal boosters must be carried out in accordance with the rules in this paragraph.

(3) Signal boosters must be deployed such that the radiated power of the each retransmitted channel, on the forward link and on the reverse link, does not exceed 5 Watts effective radiated power (ERP).

(e) *Device Specifications.* In addition to the general rules for equipment certification in §90.203(a)(2) and part 2, subpart J of this chapter, a signal booster must also meet the rules in this paragraph.

(1) The output power capability of a signal booster must be designed for deployments providing a radiated power not exceeding 5 Watts ERP for each retransmitted channel.

Test Procedure: KDB 935210 s.4.5, & 4.5.3, TIA 603-E

Adjust the internal gain control of the EUT to the maximum gain for which the equipment certification is being sought. Any EUT attenuation settings shall be set to their minimum value.

Input power levels (uplink and downlink) should be set to maximum input ratings, while confirming that the device is not capable of operating in saturation (non-linear mode) at the rated input levels, including during the performance of the input/output power measurements.

4.5.3 Power measurement Method 1: using a spectrum or signal analyzer

- a) Set the frequency span to at least 1 MHz.
- b) Set RBW = 100 kHz.
- c) Set VBW $\geq 3 \times$ RBW.
- d) Set the detector to PEAK, and trace mode to MAX HOLD.
- e) Place a marker on the peak of the signal, and record the value as the maximum power.
- f) Repeat step e) but with the EUT in place.
- g) EUT gain may be calculated as described in 4.5.5.

NOTE—Sections 90.219 and 2.1033(c) do not require gain test data; inclusion of industrial booster gain test data in test reports submitted for FCC equipment authorization is optional.

After the input and output power levels have been measured as described in the preceding subclauses, the gain of the EUT can be determined from:

$$\text{Gain (dB)} = \text{output power (dBm)} - \text{input power (dBm)}.$$

Report the gain for each authorized operating frequency band, and each test signal stimulus.

Test Setup Block Diagram: KDB 935210 s.4.5

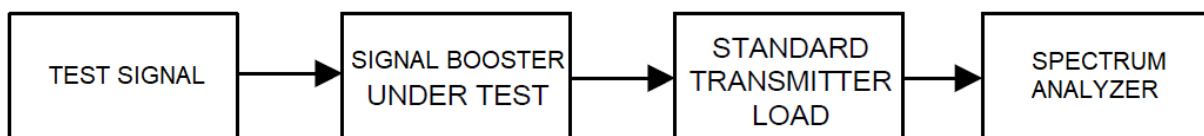

RF POWER OUTPUT

Test Data: 700 Band Measurement Table

Frequency	AGC Level	Input (dBm)	Output (dBm)	Antenna Gain (dBi)	Cable Loss (dB)	Gain (dB)	Output ERP (W)
772.0	AGC	22.45	46.86	0.00	0.00	24.4	48.53
772.0	AGC+3	25.45	47.01	0.00	0.00	21.6	50.23
772.0	Saturation	36.45	47.01	0.00	0.00	10.6	50.23
802.0	AGC	22.45	46.92	0.00	0.00	24.5	49.20
802.0	AGC+3	25.45	46.98	0.00	0.00	21.5	49.89
802.0	Saturation	36.45	46.98	0.00	0.00	10.5	49.89
815.0	AGC	22.45	46.88	0.00	0.00	24.4	48.75
815.0	AGC+3	25.45	46.93	0.00	0.00	21.5	49.32
815.0	Saturation	36.45	46.93	0.00	0.00	10.5	49.32
860.0	AGC	22.45	46.73	0.00	0.00	24.3	47.10
860.0	AGC+3	25.45	46.76	0.00	0.00	21.3	47.42
860.0	Saturation	36.45	46.76	0.00	0.00	10.3	47.42

Maximum Power Output: 47.01 dBm (50.23 W)

POWER TO FINAL AMPLIFIER

Rule Part No.: FCC Pt. 2.1033(c)(8)

Requirements:

(c) Applications for equipment other than that operating under parts 15, 11 and 18 of this chapter shall be accompanied by a technical report containing the following information:

(8) The dc voltages applied to and dc currents into the several elements of the final radio frequency amplifying device for normal operation over the power range.

Test Setup Block Diagram:

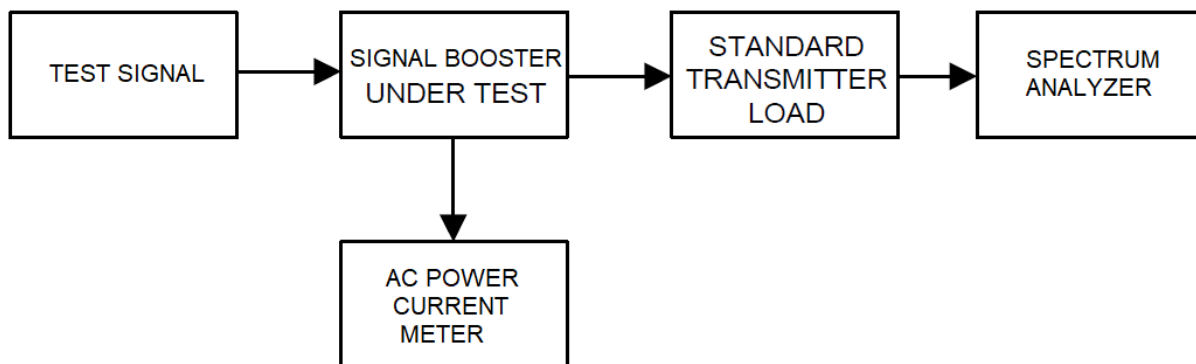

Test Data: Power to Final Amplifier Calculation

INPUT POWER: (13.8 VDC) (9.7 A) = **133.9 Watts Maximum**

NOISE FIGURE

Rule Part No.: KDB 935210 s.4.6, FCC Pt. 90.219(e)(2)

Section 90.219(e)(2) limits the noise figure of a signal booster to ≤ 9 dB in either direction. The following discussion provides guidance for demonstrating compliance with this requirement.

Several widely recognized methods for performing noise figure measurements are available. Some require the use of specialized equipment, such as a noise figure analyzer and/or an excess noise ratio (ENR) calibrated noise source, while others involve the use of conventional measurement instrumentation such as a spectrum analyzer. Methods that require use of a noise figure analyzer are generally accepted as producing the most accurate results, and are considered to be the reference method within this document, while others are considered to be acceptable alternative methods. Consult the relevant instrumentation application notes for detailed guidance regarding the selection and application of an appropriate methodology for performing noise figure measurements. Note also that noise figure measurements require that any AGC circuitry be disabled over the duration of the measurement.

Requirements:

(e) *Device Specifications.* In addition to the general rules for equipment certification in §90.203(a)(2) and part 2, subpart J of this chapter, a signal booster must also meet the rules in this paragraph.

(2) The noise figure of a signal booster must not exceed 9 dB in either direction.

Test Procedure: FCC KDB 935210 S. 4.6, ISSED RSS-131 S. 6.4 - NOISE FIGURE, per "Noise Figure Measurement Accuracy: The Y-Factor Method" (by Keysight Technologies)

Setup using an RBW of 10 kHz, VBW $\geq 3x$ RBW, Span $> 2x$ Passband, Max Hold, Peak Detector. "Noise Source off" and "Noise Source on" traces were taken.

Note: EUT's AGC method(s) and/or squelch function should be disabled for this test.

Test Setup Block Diagram:

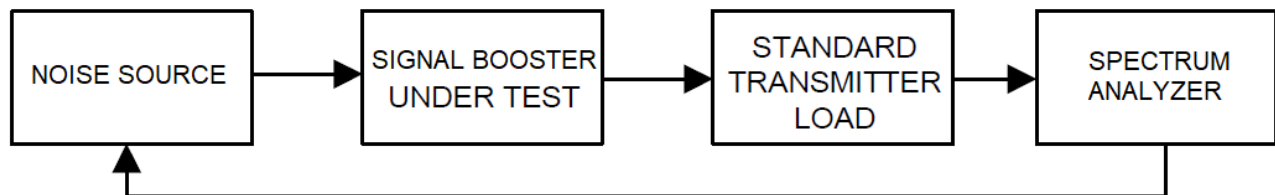

NOISE FIGURE

700 Band Noise Figure

Test Data: 700 Band Uplink Noise Calculation

802 MHz, Two-Amp Gain Method	
FCC KDB 935210 S. 4.6, ISED RSS-131 S. 6.4 - NOISE FIGURE	
Measurement Freq. (MHz)	802.00
Output at Sig Gen (dBm)	-16.000
Output at Meas. Amp (dBm)	22.445
Gain of Meas. Amp (dB)	38.445
Output at EUT Amp (dBm)	45.980
Gain of EUT Amp (dB)	23.500
Meas Bandwidth (Hz)	1000000
Meas Bandwidth (dB Hz)	60.000
Boltzmann's Const. @ 297 K	-253.32673166639
Noise Fig of Meas Path (dB)	-329.3267
Noise Fig of Meas Amp (dB)	0.000
Noise Fig of EUT Amp (dB)	0.035
Noise Figure (dB)	0.035
Limit (dB)	9.000
Margin (dB)	8.965

INTERMODULATION SPURIOUS EMISSIONS

Test Procedure: KDB 935210 s.4.7.2, TIA 603-E

Intermodulation products shall be measured using two CW signals with all available channel spacings (e.g., 12.5 kHz and 6.25 kHz) with the center between these channels being equal to the center frequency f_0 as determined from 4.4.

NOTE—Intermodulation-product spurious emission measurements are not required for single-channel boosters that cannot accommodate two simultaneous signals within the passband.

- a) Connect a signal generator to the input of the EUT.
If the signal generator is not capable of producing two independent modulated carriers simultaneously, then two discrete signal generators can be connected, with an appropriate combining network to support the two-signal test.
- b) Configure the two signal generators to produce CW on frequencies spaced consistent with 4.7.1, with amplitude levels set to just below the AGC threshold (see 4.2).
- c) Connect a spectrum analyzer to the EUT output.
- d) Set the span to 100 kHz.
- e) Set RBW = 300 Hz with VBW $\geq 3 \times$ RBW.
- f) Set the detector to power averaging (rms).
- g) Place a marker on highest intermodulation product amplitude.
- h) Capture the plot for inclusion in the test report.
- i) Repeat steps c) to h) with the composite input power level set to 3 dB above the AGC threshold.
- j) Repeat steps b) to i) for all operational bands.

Test Setup Block Diagram: KDB 935210 s.4.7.2

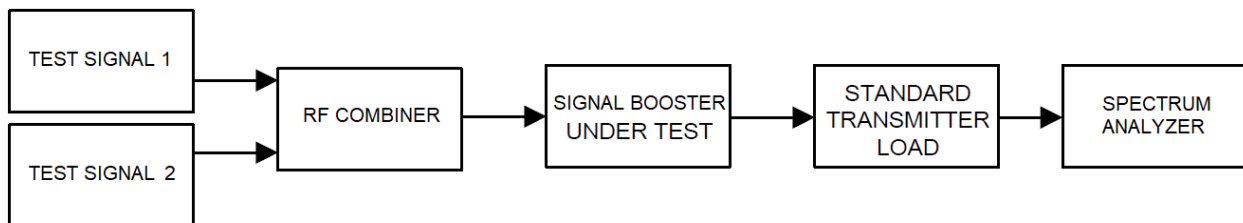

Test Data: n/a

Note: The EUT will be used exclusively by a single transmitter, and as such is considered a single channel booster which will not amplify multiple signals.

SPURIOUS EMISSIONS AT ANTENNA TERMINALS

Rule Part No.: KDB 935210 s.4.7.3, FCC Part 2.1051(a), FCC Pt. 90.219(e)(3)

Refer to the applicable rule part(s) for specified limits on unwanted (out-of-band/out-of-block and spurious) emissions (e.g., Section 90.210).

Requirements:

(e) *Device Specifications.* In addition to the general rules for equipment certification in §90.203(a)(2) and part 2, subpart J of this chapter, a signal booster must also meet the rules in this paragraph.

(3) Spurious emissions from a signal booster must not exceed -13 dBm within any 100 kHz measurement bandwidth.

Test Procedure: KDB 935210 s.4.7.3, TIA 603-E

Spurious emissions shall be measured using a single test signal sequentially tuned to the low, middle, and high channels or frequencies within each authorized frequency band of operation.

- a) Connect a signal generator to the input of the EUT.
- b) Configure the signal generator to produce a CW signal.
- c) Set the frequency of the CW signal to the center channel of the EUT passband.
- d) Set the output power level so that the resultant signal is just below the AGC threshold (see 4.2).
- e) Connect a spectrum analyzer to the output of the EUT, using appropriate attenuation as necessary.
- f) Set the RBW = 100 kHz. (i.e., for 30 MHz to 1 GHz PLMRS and/or PSRS booster devices)
- g) Set the VBW = $3 \times$ RBW.
- h) Set the Sweep time = auto-couple.
- i) Set the detector to PEAK.
- j) Set the spectrum analyzer start frequency to 30 MHz (or the lowest radio frequency signal generated in the EUT, without going below 9 kHz if the EUT has additional internal clock frequencies), and the stop frequency to 10 times the highest allowable frequency of the EUT passband.
- k) Select MAX HOLD, and use the marker peak function to find the highest emission(s) outside the passband. (This could be either at a frequency lesser or greater than the passband frequencies.)
- l) Capture a plot for inclusion in the test report.
- m) Repeat steps c) to l) for each authorized frequency band/block of operation.

Test Setup Block Diagram: KDB 935210 s.4.7.3

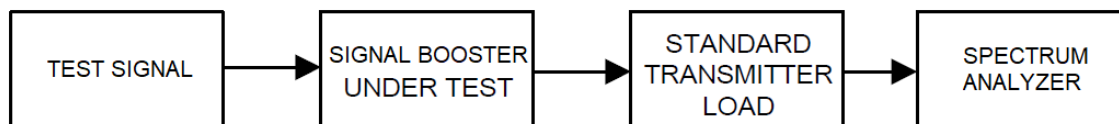

Note 1: The standard method was deviated from during testing. Instead of four discrete frequencies, the entire passband was swept from 769 – 869 MHz to generate all possible spurious emissions.

Note 2: The standard method was deviated from during testing. Instead of using an input signal at AGC level, the input signal was at the maximum power input level of the EUT (4 W).

Applicant: CRESCEND TECHNOLOGIES, LLC
 FCC ID: CWW DSDTJK50
 Report: 2233AUT19TestReport_Rev1

SPURIOUS EMISSIONS AT ANTENNA TERMINALS

Test Data: Conducted Spurious Emissions Below 1 GHz

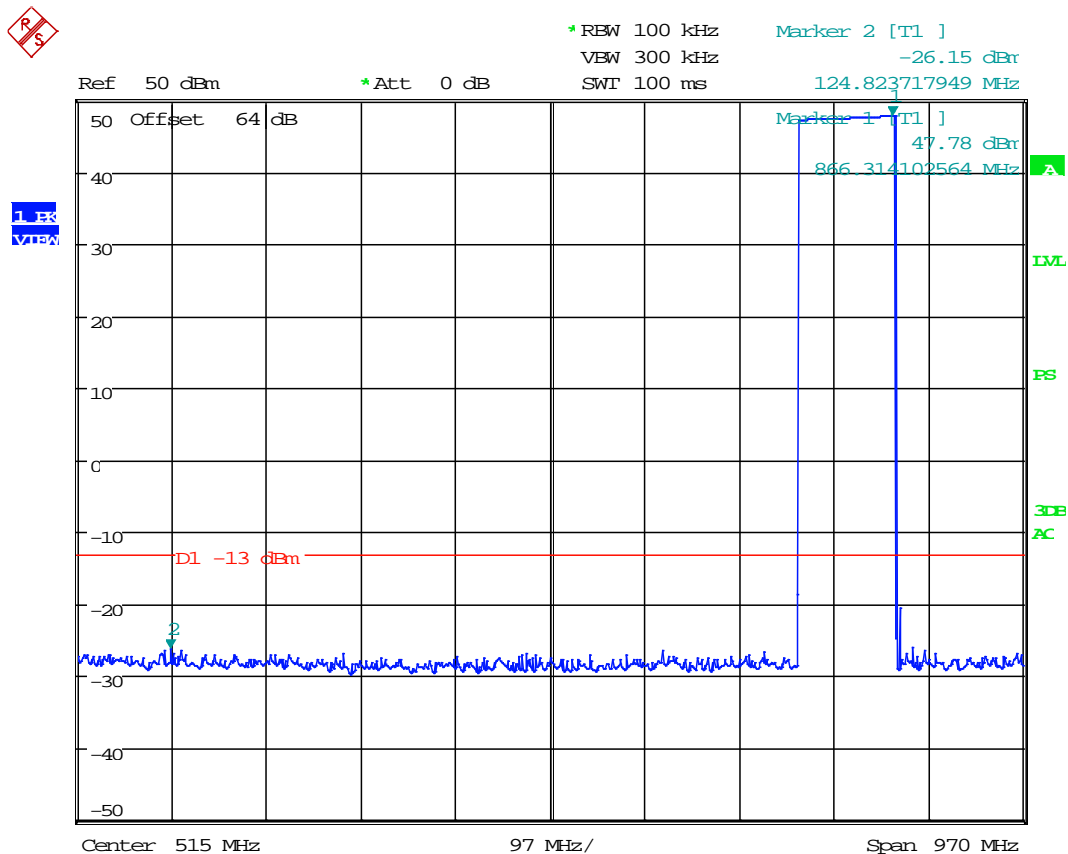

Date: 28.AUG.2019 15:12:33

SPURIOUS EMISSIONS AT ANTENNA TERMINALS

Test Data: Conducted Spurious Emissions Above 1 GHz

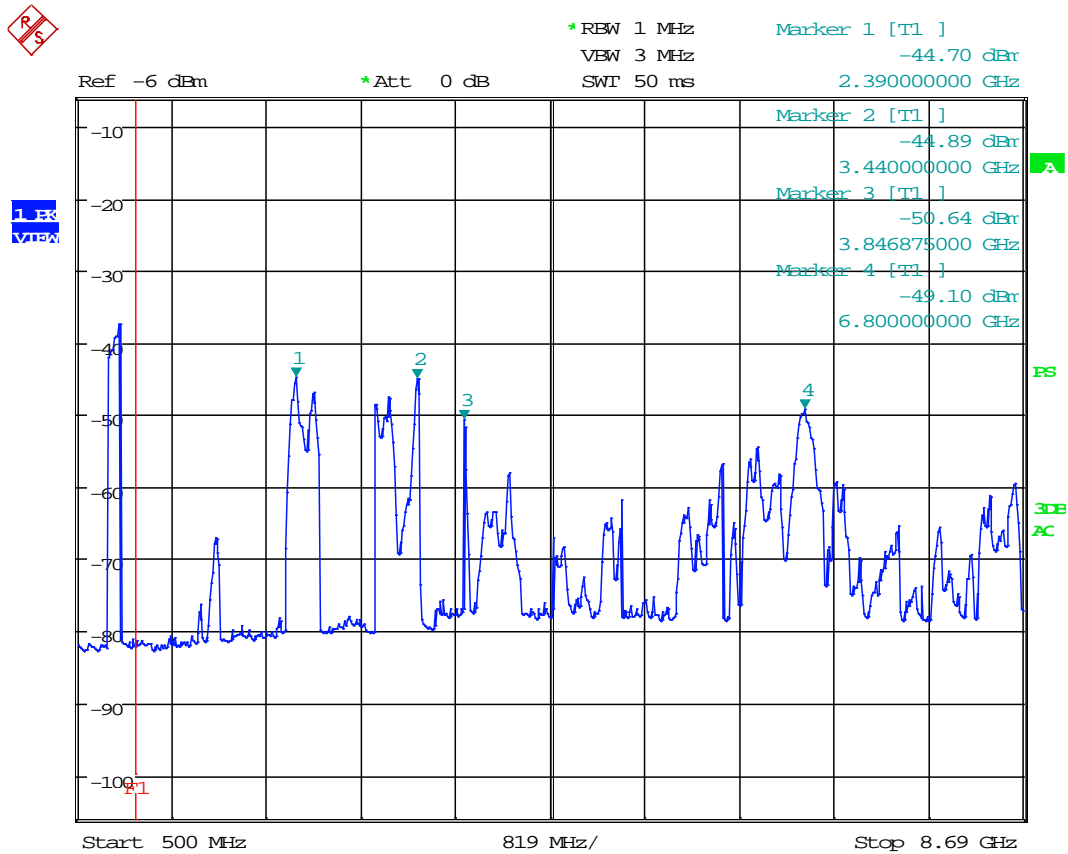

Date: 28.AUG.2019 16:18:45

Note: The Frequency Line "F1" was placed at 1 GHz. The emission below this line is the fundamental emission, swept per Note 1 at the beginning of this section, at full power per Note 2 at the beginning of this section.

Frequency	Fund. Frequency	Harmonic	Measured Level (dBm)	Loss (dB)	Output (dBm)	Limit (dBm)	Margin (W)
2390.00	796.66	3rd	-44.7	18.65	-26.05	-13.00	13.05
3440.00	860.00	4th	-44.89	20.48	-24.41	-13.00	11.41
3846.88	769.20	5th	-50.64	21.49	-29.15	-13.00	16.15
6800.00	850.00	8th	-49.10	23.68	-25.42	-13.00	12.42

FREQUENCY STABILITY

Rule Part No.: KDB 935210 s.4.8, FCC Part 2.1055(a)(1), FCC Pt. 90.219(e)(4)(i)

Section 90.219(e)(4)(i) requires that a signal being retransmitted by an amplifier, repeater, or industrial booster meets the frequency stability requirements of Section 90.213. However, this requirement presumes that the EUT processes an input signal in ways that can influence the output signal frequency/frequencies; however, most signal boosters do not incorporate an oscillator). If the amplifier, booster, or repeater does not alter the input signal in any way, then a frequency stability test may not be required.

Requirements: FCC Part 2.1055(a)(1)

(a) The frequency stability shall be measured with variation of ambient temperature as follows:

(1) From -30° to $+50^{\circ}$ centigrade for all equipment except that specified in paragraphs (a) (2) and (3) of this section.

Test Procedure: KDB 935210 s.4.8, FCC Part 2.1055(b), TIA 603-E

When performing frequency stability measurements on these types of devices, the instability associated with the EUT must be isolated from any frequency instability associated with the measurement instrumentation. One method for realizing such isolation is to connect the reference clock input of the signal generator to the reference output of the frequency counter, to confirm that any frequency instability is associated with the EUT, and is not due to differences between the reference oscillators internal to the measurement instrumentation.

(b) Frequency measurements shall be made at the extremes of the specified temperature range and at intervals of not more than 10° centigrade through the range. A period of time sufficient to stabilize all of the components of the oscillator circuit at each temperature level shall be allowed prior to frequency measurement. The short term transient effects on the frequency of the transmitter due to keying (except for broadcast transmitters) and any heating element cycling normally occurring at each ambient temperature level also shall be shown. Only the portion or portions of the transmitter containing the frequency determining and stabilizing circuitry need be subjected to the temperature variation test.

Test Setup Block Diagram:

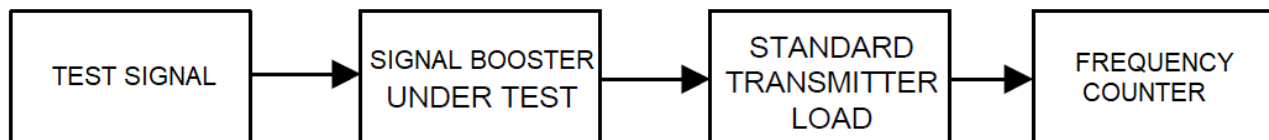

RESULT: Not Applicable to EUT.

FIELD STRENGTH OF SPURIOUS EMISSIONS

Rule Part No.: KDB 935210 s.4.9, FCC Part 2.1053(a), FCC Pt. 90.219(e)(3)

Refer to the applicable rule part(s) for specified limits on unwanted (out-of-band/out-of-block and spurious) emissions (e.g., Section 90.210).

Requirements:

(e) *Device Specifications.* In addition to the general rules for equipment certification in §90.203(a)(2) and part 2, subpart J of this chapter, a signal booster must also meet the rules in this paragraph.

(3) Spurious emissions from a signal booster must not exceed -13 dBm within any 100 kHz measurement bandwidth.

Test Procedure: KDB 935210 s.4.7.3, TIA 603-E

Spurious emissions shall be measured using a single test signal sequentially tuned to the low, middle, and high channels or frequencies within each authorized frequency band of operation.

- a) Connect a signal generator to the input of the EUT.
- b) Configure the signal generator to produce a CW signal.
- c) Set the frequency of the CW signal to the center channel of the EUT passband.
- d) Set the output power level so that the resultant signal is just below the AGC threshold (see 4.2).
- e) Connect a spectrum analyzer to the output of the EUT, using appropriate attenuation as necessary.
- f) Set the RBW = 100 kHz. (i.e., for 30 MHz to 1 GHz PLMRS and/or PSRS booster devices)
- g) Set the VBW = $3 \times$ RBW.
- h) Set the Sweep time = auto-couple.
- i) Set the detector to PEAK.
- j) Set the spectrum analyzer start frequency to 30 MHz (or the lowest radio frequency signal generated in the EUT, without going below 9 kHz if the EUT has additional internal clock frequencies), and the stop frequency to 10 times the highest allowable frequency of the EUT passband.
- k) Select MAX HOLD, and use the marker peak function to find the highest emission(s) outside the passband. (This could be either at a frequency lesser or greater than the passband frequencies.)
- l) Capture a plot for inclusion in the test report.
- m) Repeat steps c) to l) for each authorized frequency band/block of operation.

FIELD STRENGTH OF SPURIOUS EMISSIONS

Test Site Setup:

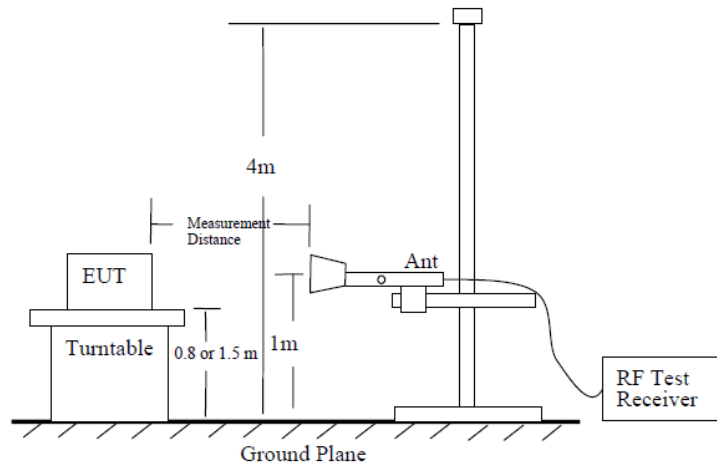

EUT Orientation(s):

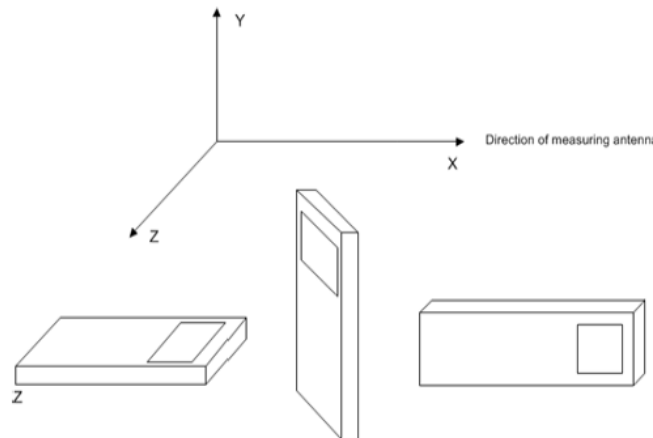

Note: The tabulated data shows the results of the radiated field strength emissions test. The spectrum was scanned from the lowest frequency generated internally to at least the tenth harmonic of the fundamental. This test was conducted in accordance with the standard listed above using the substitution method. Measurements were made at the test site of TIMCO ENGINEERING, INC. located at 849 NW State Road 45, Newberry, FL 32669. The measurements below represent the worst case of all the frequencies tested.

Note: Six (6) or more of the highest emissions of each worst-case operational mode of the EUT are represented below. Emissions 20 dB below the limit were not required to be reported.

Note: The EUT was supplied with the worst-case in-band input signals (determined in Conducted Spurious Emissions) at Maximum Input Power (4W) of the EUT.

FIELD STRENGTH OF SPURIOUS EMISSIONS

769.2 MHz Radiated Spurious Emissions

Tuned Frequency (MHz)	Emission Frequency (MHz)	Detector	Meter Reading (dBµV)	Antenna Polarity	Coax Loss (dB)	Correction Factor (dB/m)	Distance (m)	Field Strength (dBµV/m)	ERP (dBm)	Limit (dBm)	Margin (dBm)
769.20	38.02	PK	4.85	V	0.69	13.40	3.00	18.94	-78.44	-13.00	65.44
769.20	103.58	PK	6.53	V	1.17	10.64	3.00	18.34	-79.03	-13.00	66.03
769.20	224.32	PK	1.48	V	1.72	10.30	3.00	13.50	-83.88	-13.00	70.88
769.20	406.72	PK	1.61	V	2.30	14.70	3.00	18.61	-78.76	-13.00	65.76
769.20	1538.40	PK	15.96	H	4.56	27.76	3.00	48.28	-49.10	-13.00	36.10
769.20	1538.40	PK	19.33	V	4.56	27.76	3.00	51.65	-45.73	-13.00	32.73
769.20	2307.60	PK	23.76	H	5.51	31.59	3.00	60.86	-36.51	-13.00	23.51
769.20	2307.60	PK	24.49	V	5.51	31.59	3.00	61.59	-35.78	-13.00	22.78
769.20	3076.80	PK	23.14	H	6.41	32.70	3.00	62.25	-35.13	-13.00	22.13
769.20	3076.80	PK	23.38	V	6.41	32.70	3.00	62.49	-34.89	-13.00	21.89
769.20	3846.00	PK	16.17	H	7.23	33.20	3.00	56.60	-40.78	-13.00	27.78
769.20	3846.00	PK	21.87	V	7.23	33.20	3.00	62.30	-35.08	-13.00	22.08
769.20	5384.40	PK	17.12	H	8.16	34.33	3.00	59.61	-37.77	-13.00	24.77
769.20	5384.40	PK	19.60	V	8.16	34.33	3.00	62.09	-35.29	-13.00	22.29
769.20	6153.60	PK	13.46	H	8.59	35.34	3.00	57.39	-39.99	-13.00	26.99
769.20	6153.60	PK	15.42	V	8.59	35.34	3.00	59.35	-38.03	-13.00	25.03
769.20	6922.80	PK	19.49	H	9.23	36.03	3.00	64.75	-32.63	-13.00	19.63
769.20	6922.80	PK	26.29	V	9.23	36.03	3.00	71.55	-25.83	-13.00	12.83

799.0 MHz Radiated Spurious Emissions

Tuned Frequency (MHz)	Emission Frequency (MHz)	Detector	Meter Reading (dBµV)	Antenna Polarity	Coax Loss (dB)	Correction Factor (dB/m)	Distance (m)	Field Strength (dBµV/m)	ERP (dBm)	Limit (dBm)	Margin (dBm)
799.00	64.54	PK	1.71	H	0.95	6.29	3.00	8.95	-88.43	-13.00	75.43
799.00	103.71	PK	7.01	H	1.17	10.63	3.00	18.81	-78.56	-13.00	65.56
799.00	341.44	PK	1.68	V	2.12	13.70	3.00	17.50	-79.88	-13.00	66.88
799.00	502.08	PK	2.92	H	2.66	17.44	3.00	23.02	-74.36	-13.00	61.36
799.00	1598.00	PK	25.33	V	4.65	28.06	3.00	58.04	-39.33	-13.00	26.33
799.00	1598.00	PK	21.35	H	4.65	28.06	3.00	54.06	-43.31	-13.00	30.31
799.00	2397.00	PK	24.76	V	5.62	31.88	3.00	62.26	-35.12	-13.00	22.12
799.00	2397.00	PK	24.22	H	5.62	31.88	3.00	61.72	-35.66	-13.00	22.66
799.00	3196.00	PK	18.62	V	6.57	32.68	3.00	57.87	-39.51	-13.00	26.51
799.00	3196.00	PK	16.64	H	6.57	32.68	3.00	55.89	-41.49	-13.00	28.49
799.00	3995.00	PK	15.12	V	7.24	33.40	3.00	55.76	-41.62	-13.00	28.62
799.00	4794.00	PK	12.65	V	7.05	33.93	3.00	53.63	-43.74	-13.00	30.74
799.00	4794.00	PK	10.97	H	7.05	33.93	3.00	51.95	-45.42	-13.00	32.42
799.00	5593.00	PK	14.91	V	8.19	34.44	3.00	57.54	-39.84	-13.00	26.84
799.00	5593.00	PK	13.79	H	8.19	34.44	3.00	56.42	-40.96	-13.00	27.96
799.00	6392.00	PK	28.46	V	8.86	35.44	3.00	72.76	-24.62	-13.00	11.62
799.00	6392.00	PK	24.47	H	8.86	35.44	3.00	68.77	-28.61	-13.00	15.61
799.00	7191.00	PK	13.90	V	9.46	36.40	3.00	59.76	-37.61	-13.00	24.61
799.00	7990.00	PK	11.00	V	9.97	35.72	3.00	56.69	-40.69	-13.00	27.69

FIELD STRENGTH OF SPURIOUS EMISSIONS

815.0 MHz Radiated Spurious Emissions

Tuned Frequency (MHz)	Emission Frequency (MHz)	Detector	Meter Reading (dBμV)	Antenna Polarity	Coax Loss (dB)	Correction Factor (dB/m)	Distance (m)	Field Strength (dBμV/m)	ERP (dBm)	Limit (dBm)	Margin (dBm)
815.00	119.49	PK	8.71	V	1.25	10.65	3.00	20.61	-76.77	-13.00	63.77
815.00	179.87	PK	0.73	H	1.56	13.91	3.00	16.20	-81.18	-13.00	68.18
815.00	664.00	PK	3.00	H	3.01	19.72	3.00	25.73	-71.65	-13.00	58.65
815.00	781.76	PK	2.69	H	3.30	21.86	3.00	27.85	-69.53	-13.00	56.53
815.00	1630.00	PK	25.31	V	4.71	28.39	3.00	58.41	-38.97	-13.00	25.97
815.00	1630.00	PK	18.52	H	4.71	28.39	3.00	51.62	-45.76	-13.00	32.76
815.00	2445.00	PK	24.24	V	5.62	31.84	3.00	61.70	-35.68	-13.00	22.68
815.00	2445.00	PK	26.16	H	5.62	31.84	3.00	63.62	-33.76	-13.00	20.76
815.00	3260.00	PK	17.58	V	6.66	32.67	3.00	56.91	-40.47	-13.00	27.47
815.00	3260.00	PK	15.97	H	6.66	32.67	3.00	55.30	-42.08	-13.00	29.08
815.00	4075.00	PK	16.06	V	7.15	33.39	3.00	56.60	-40.78	-13.00	27.78
815.00	5705.00	PK	15.78	H	8.18	34.61	3.00	58.57	-38.81	-13.00	25.81
815.00	5705.00	PK	13.08	V	8.18	34.61	3.00	55.87	-41.51	-13.00	28.51
815.00	6520.00	PK	20.79	V	9.09	35.55	3.00	65.43	-31.94	-13.00	18.94
815.00	6520.00	PK	18.92	H	9.09	35.55	3.00	63.56	-33.81	-13.00	20.81
815.00	7335.00	PK	11.01	V	9.46	36.20	3.00	56.67	-40.71	-13.00	27.71
815.00	8150.00	PK	14.05	V	9.98	35.80	3.00	59.83	-37.55	-13.00	24.55
815.00	8150.00	PK	11.44	H	9.98	35.80	3.00	57.22	-40.16	-13.00	27.16

860.0 MHz Radiated Spurious Emissions

Tuned Frequency (MHz)	Emission Frequency (MHz)	Detector	Meter Reading (dBμV)	Antenna Polarity	Coax Loss (dB)	Correction Factor (dB/m)	Distance (m)	Field Strength (dBμV/m)	ERP (dBm)	Limit (dBm)	Margin (dBm)
860.00	131.32	PK	1.51	H	1.30	13.36	3.00	16.17	-81.21	-13.00	68.21
860.00	186.54	PK	0.97	V	1.58	13.40	3.00	15.95	-81.43	-13.00	68.43
860.00	678.08	PK	2.10	V	3.05	20.92	3.00	26.07	-71.31	-13.00	58.31
860.00	824.73	PK	1.47	V	3.40	20.89	3.00	25.76	-71.62	-13.00	58.62
860.00	946.24	PK	1.68	V	3.60	22.65	3.00	27.93	-69.44	-13.00	56.44
860.00	1720.00	PK	26.99	V	4.81	29.33	3.00	61.13	-36.25	-13.00	23.25
860.00	1720.00	PK	22.67	H	4.81	29.33	3.00	56.81	-40.57	-13.00	27.57
860.00	2580.00	PK	26.58	V	5.76	32.49	3.00	64.83	-32.55	-13.00	19.55
860.00	2580.00	PK	24.89	H	5.76	32.49	3.00	63.14	-34.24	-13.00	21.24
860.00	3440.00	PK	33.14	V	6.82	32.61	3.00	72.57	-24.80	-13.00	11.80
860.00	3440.00	PK	35.65	H	6.82	32.61	3.00	75.08	-22.29	-13.00	9.29
860.00	4300.00	PK	14.93	V	7.23	33.46	3.00	55.62	-41.76	-13.00	28.76
860.00	4300.00	PK	11.86	H	7.23	33.46	3.00	52.55	-44.83	-13.00	31.83
860.00	5160.00	PK	11.70	V	7.82	34.11	3.00	53.63	-43.75	-13.00	30.75
860.00	6020.00	PK	12.98	V	8.65	35.15	3.00	56.78	-40.60	-13.00	27.60
860.00	6020.00	PK	11.47	H	8.65	35.15	3.00	55.27	-42.11	-13.00	29.11
860.00	6880.00	PK	32.70	V	9.22	35.90	3.00	77.82	-19.56	-13.00	6.56
860.00	6880.00	PK	30.57	H	9.22	35.90	3.00	75.69	-21.69	-13.00	8.69
860.00	7740.00	PK	11.01	H	10.11	35.87	3.00	56.99	-40.39	-13.00	27.39
860.00	8600.00	PK	11.81	V	10.18	36.04	3.00	58.03	-39.35	-13.00	26.35
860.00	8600.00	PK	15.16	H	10.18	36.04	3.00	61.38	-36.00	-13.00	23.00

STATEMENT OF MEASUREMENT UNCERTAINTY

The data and results referenced in this document are true and accurate. The measurement uncertainty was calculated for all measurements listed in this test report according To CISPR 16-4 or ENTR 100-028 Specification for radio disturbance and immunity measuring apparatus and methods – Part 4: “Uncertainty in EMC Measurements” and is documented in the Timco Engineering, Inc. quality system according to DIN EN ISO/IEC 17025. Furthermore, component and process variability of devices similar to that tested may result in additional deviation. The manufacturer has the sole responsibility of continued compliance of the device.

Hereafter the best measurement capability for Timco Engineering, Inc. is reported:

Test Items	Measurement Uncertainty	Notes
RF Frequency Accuracy	± 49.5 Hz	(1)
RF Conducted Power	±0.93dB	(1)
Conducted spurious emission of transmitter valid up to 40GHz	±1.86dB	
Occupied Bandwidth	±2.65%	
Radiated RF Power	±1.4dB	
Rad Emissions Sub Meth up to 26.5GHz	±2.14dB	
Adjacent channel power	±0.93dB	(1)

Notes: (1) This uncertainty represents an expanded uncertainty expressed at approximately the 95% confidence level using a coverage factor of k=1.96.

EMC EQUIPMENT LIST

Device	Manufacturer	Model	Serial Number	Cal/Char Date	Due Date
Antenna: Biconical 1057	Eaton	94455-1	1057	12/13/17	12/13/19
Antenna: Log-Periodic 1243	Eaton	96005	1243	04/20/18	04/20/20
Coaxial Cable - Chamber 3 cable set (backup)	Micro-Coax	Chamber 3 cable set (backup)	KMKM-0244-02 KMKM-0670-01 KFKF-0197-00	02/27/19	02/27/21
CHAMBER	Panashield	3M	N/A	03/12/19	03/12/21
Antenna: Double-Ridged Horn/ETS Horn 1	ETS-Lindgren	3117	00035923	01/30/17	01/30/20
Software: Field Strength Program	Timco	N/A	Version 4.10.7.0	N/A	N/A
EMI Test Receiver R & S ESU 40	Rohde & Schwarz	ESU 40	100320	08/28/18	08/28/20
Bore-sight Antenna Positioning Tower	Sunol Sciences	TLT2	N/A	N/A	N/A
Attenuator N 30dB 100W DC-6G	Pasternack	PE7214-30	#109	08/23/19	08/23/21
Coaxial Cable - BMBM-0061-01 RG400	Pasternack	PE3582LF-24	BMBM-0061-01	08/23/19	08/23/21
Coaxial Cable - BMBM-0061-02 RG400	Pasternack	PE3582LF-24	BMBM-0061-02	08/23/19	08/23/21
Coaxial Cable - BMBM-0122-01 RG400	Pasternack	PE3582LF-48	BMBM-0122-01	08/23/19	08/23/21
Coaxial Cable - BMBM-0122-02 RG400	Pasternack	PE3582LF-48	BMBM-0122-02	08/23/19	08/23/21
Coaxial Cable - BMBM-0183-01 RG400	Pasternack	PE3582LF-72	BMBM-0183-01	08/23/19	08/23/21
Coaxial Cable - BMBM-0183-02 RG400	Pasternack	PE3582LF-72	BMBM-0183-02	08/23/19	08/23/21
Terminator N 20W DC-18G	Narda	8205	#14	N/A	N/A
10 W Amplifier	Amplifier Research	10W1000B	23117	08/23/19	08/23/21
Signal Generator R & S SMU 200A	Rohde & Schwarz	SMU200A	103195	04/23/18	04/23/20
Signal Generator HP 8648C	HP	8648C	3537A01679	03/29/19	03/29/21

*EMI RECEIVER SOFTWARE VERSION

The receiver firmware used was version 4.43 Service Pack 3

END OF TEST REPORT