



CONTENTS

- 1. PREFACE**
- 2. PASSIVE ACCESS ENTRY FUNCTIONALITY**
 - 2.1. Door Unlocking
 - 2.2. Engine Start
 - 2.3. Engine Stop
 - 2.4. Door Locking (Push switch)
- 3. ACTIVE ACCESS ENTRY FUNCTIONALITY**
 - 3.1. Door Unlocking
 - 3.2. Engine Start
 - 3.3. Engine Stop
 - 3.4. Door Locking
 - 3.5. Trunk Open
- 4. ENTRY SYSTEM OPTIONS**
 - 4.1. System Schematic
 - 4.2. Modules
 - 4.2.1. FOB ECU
 - 4.2.2. Entry System ECU
- 5. SYSTEM CHARACTERISTICS**
 - 5.1. Antenna Areas
 - 5.2. Exciter Locations
 - 5.3. Switch Input Locations (Door handle)
- 6. ELECTRICAL CHARACTERISTICS**
 - 6.1. FOB
 - 6.2. Entry System ECU

FCC WARNING

NOTICE



1. Preface

This document describes the requirements and operation of the Passive Entry System. However, this document is especially for the Entry system ECU (acronym for Electric Control Unit) and the FOB.

The FOB consists the following functionality for passive access and active access:

- Door unlocking / locking (however, only for request by means of switch operation)
- Trunk open (however, only for request by means of switch operation)
- LF decoding
- RF encoding
- Communication data encryption (cryptograph, anti-collision, rolling code and stuff)

And the entry system ECU consists of the following functionality:

- Door unlocking / locking
- Trunk open
- Engine start (/ stop)
- LF encoding
- RF encoding
- Communication data encryption (cryptograph, anti-collision, rolling code and stuff)
- LF antenna unit control
- Communication with the node ECUs connected to the body bus (e.g. CAN, J1850, customer dependent bus)

As a further function, both the FOB and the entry system ECU provides the following function:

- Learning mode for programming the manufacturing data and stuff
- Data locking and password protection
- Diagnostic (based upon ISO9141 if required)

ALPS[®]

2.Passive Access Entry Functionality

A handle sw located on, for example the door handles, mirrors and trunk lid will be used for proximity check if user is in neighborhood of the vehicle. The switch input will trigger for unlocking and open the doors and trunk.



Figure 1

2.1.Door Unlocking

- User pushes door handle sw.
- ECU sends LF-challenge via exterior antenna.
- FOB sends RF-response to the ECU.
- Door unlocking status is engaged.
- Doors are opened.



Figure 2

ALPS[®]

2.2.Engine Start

- User operates the engine start knob.
- ECU sends LF-challenge via interior antenna.
- FOB sends RF-response to the ECU.
- Immobilizer ECU receives and authorize the response.
- Engine controller ECU receives the authorization for engine strat.
- Start the engine.

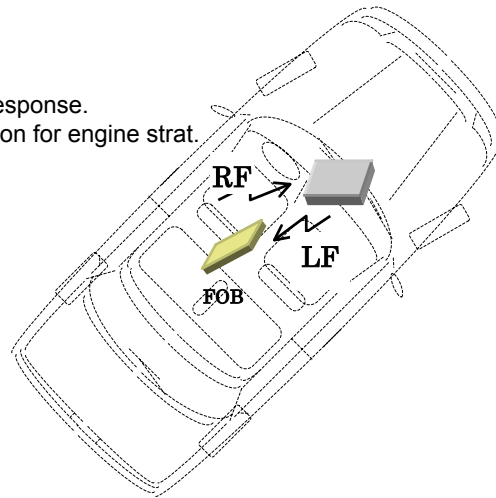

Figure 3

2.3.Engine Stop

- User operates the engine stop knob.
- ECU communicates with the other ECU for engine start request.
- Engine controller ECU receives the request.
- Stop the engine



Figure 4

ALPS[®]

2.4. Door Locking (Push switch)

- User closes the door and pushes the switch (sensing of door locking switch).
- ECU sends LF-challenge via exterior antenna.
- FOB sends RF-response to the ECU.
- Door locking status is engaged.
- Doors are locked.
- (Indicates the door locking status by means of Flasher / Buzzer or stuff)



Figure 5



3.Active Access Entry Functionality

3.1.Door Unlocking

Same functionality as the current one.

3.2.Engine Start

This function does not effect on the active entry system.

3.3.Engine Stop

This function does not have influence on the active entry system.

3.4.Door Locking

Same functionality as the current one.

3.5.Trunk Open

Same functionality as the current one.

4. Entry System Options

4.1. System Schematic

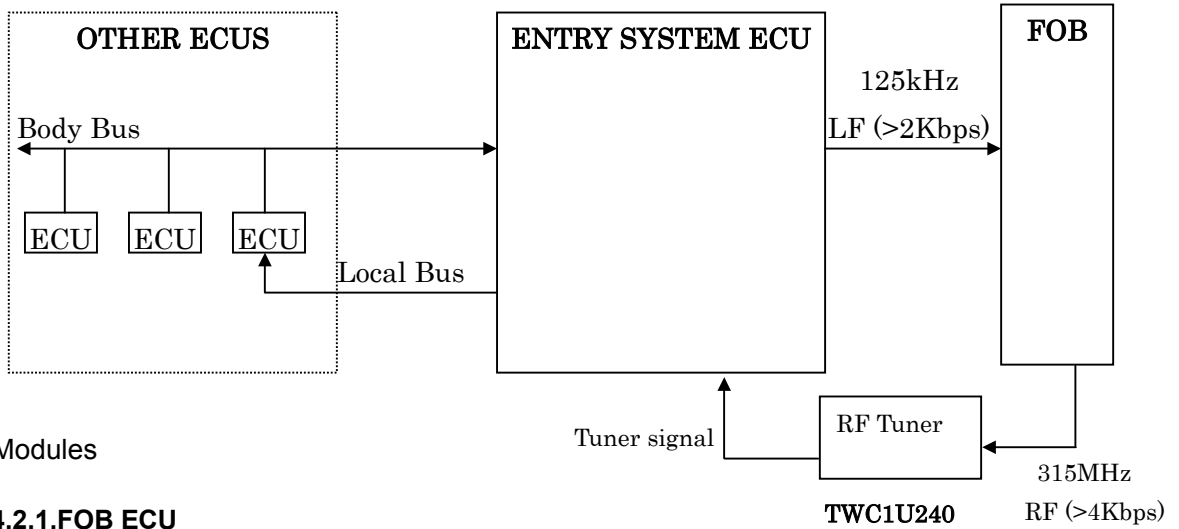

4.2. Modules

4.2.1. FOB ECU

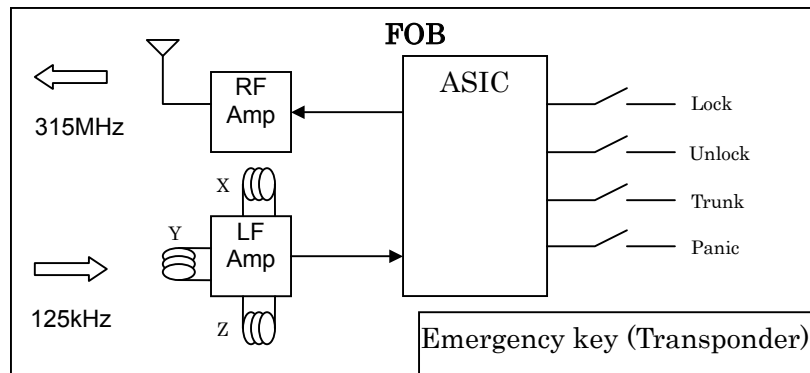

4.2.2. Entry System ECU

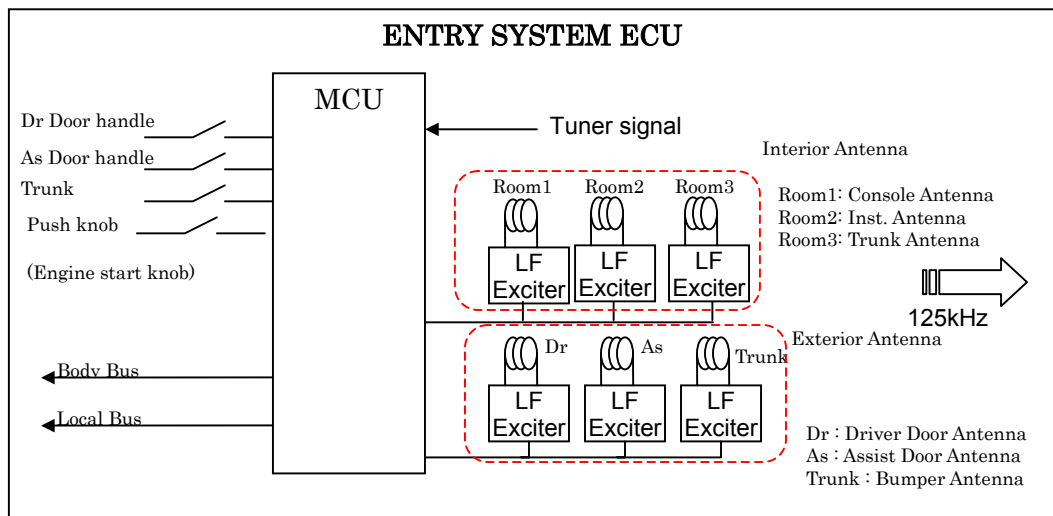

5. System Characteristics

5.1. Antenna Areas

Exterior operating range: 0.8m to 1.5m
Interior operating range: Only inside the car

Number of the exterior exciters : typ.3, however, it is depending on the type of the vehicle.
Number of the interior exciters: max.4 (min.2)

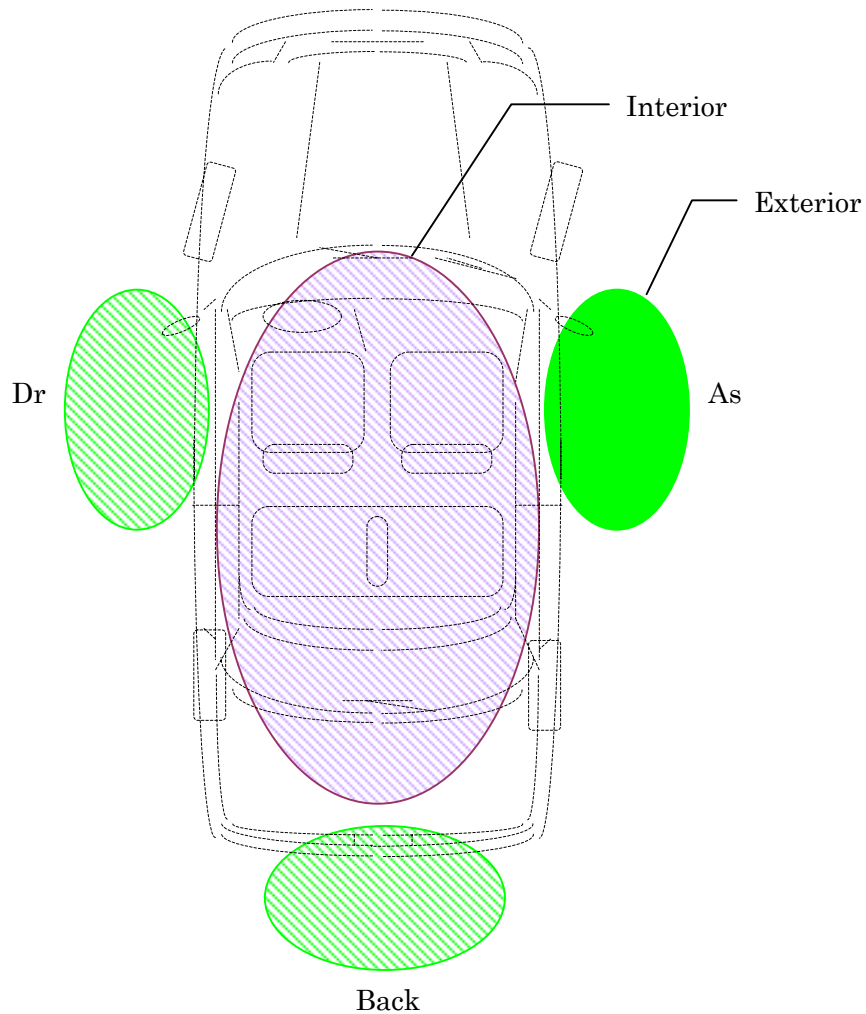

Figure 6

Exterior antenna functionality:

- Unlock / lock doors.
- Open trunk.
- Activate / deactivate alarm system.
- Activate immobilizer

Interior antenna functionality:

- Deactivate immobilizer
- Engine start

ALPS[®]

5.2. Exciter Locations

- Exterior exciters: 3 doors
- Interior exciters: 1 Center Console
- 2 Inst panel
- 3 Trunk

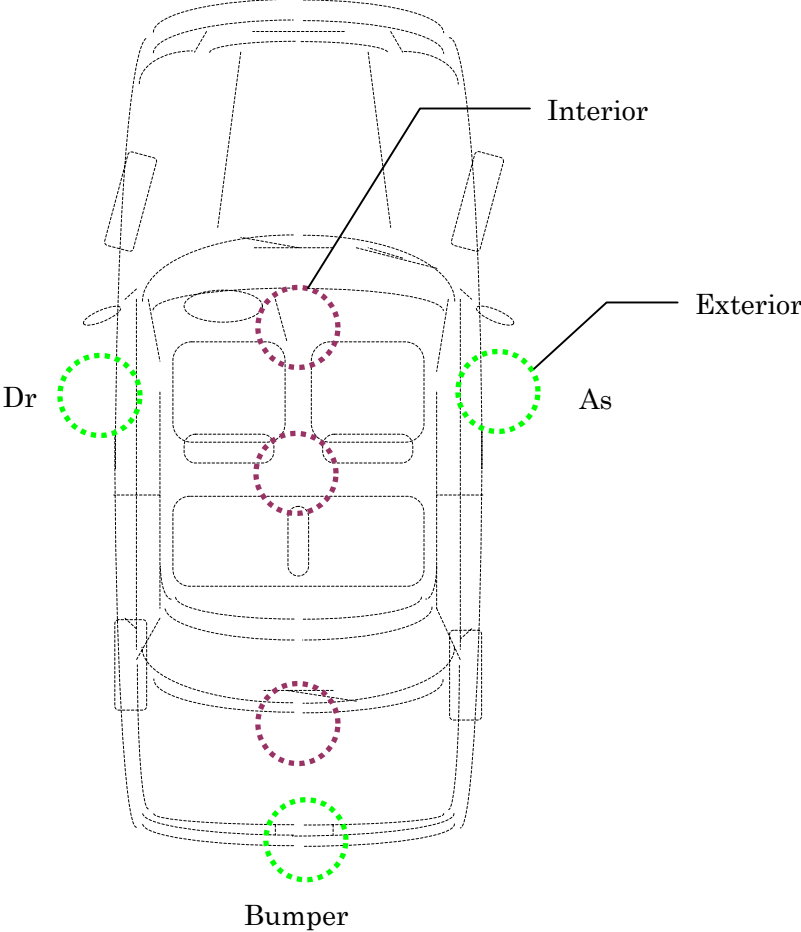

Figure 7

Antenna location can be different among of type of the vehicle (e.g. coupe, sedan, mini and stuff).

ALPS[®]

5.3. Switch Input Locations (Door handle)

There are some switches, for instance the door handle contact switch will be used as a triggering for unlocking and open the door.

Switch inputs: 3 doors

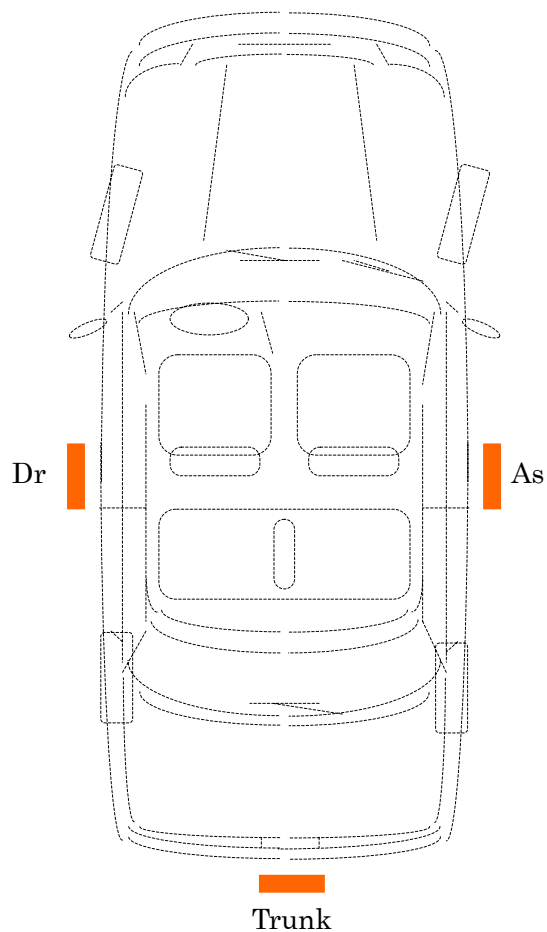

Figure 8

Switch inputs can be different among of type of the vehicle (e.g. coupe, sedan, mini and stuff).



6. Electrical Characteristics

6.1. FOB

- ASK / FSK modulation
- Operating supply voltage 2.5V ~ 3.3V (3.0V Battery)
- Operating supply current < 35mA
- Stand-by current < 10.0uA
- Operating ambient temperature -10°C to +60°C
- Antenna direction 3-Dimension (X, Y, Z), to be considered

- Battery life 1.5 Years (Low battery indication is considered)

6.2. Entry System ECU

- Operating supply voltage 9.0V ~ 16.0V
- Operating supply current < 55mA
- Stand-by current < 4.0mA
- Operating ambient temperature -30°C to +80°C
-



FCC WARNING

Changes or modifications not expressly approved by the party responsible for compliance could void the user's authority to operate the equipment.

NOTICE

This device complies with Part 15 of the FCC Rules and RSS-Gen of IC Rules.

Operation is subject to the following two conditions:

- (1) this device may not cause harmful interference, and
- (2) this device must accept any interference received, including interference that may cause undesired operation.