





EMI TEST REPORT

Test Report No. 15276765H

Customer	ALPS ALPINE CO., LTD.
Description of EUT	TPMS/KEYLESS TUNER
Model Number of EUT	TD1G316
FCC ID	CWTD1G316
Test Regulation	FCC Part 15 Subpart B
Test Result	Complied
Issue Date	June 6, 2024
Remarks	-

Representative test engineer	Approved by
	
Tetsuro Yoshida Engineer	Shinichi Miyazono Engineer
 	
CERTIFICATE 5107.02	
<input type="checkbox"/> The testing in which "Non-accreditation" is displayed is outside the accreditation scopes in UL Japan, Inc.	
<input checked="" type="checkbox"/> There is no testing item of "Non-accreditation".	

Report Cover Page - Form-ULID-003532 (DCS:13-EM-F0429) Issue# 23.0

ANNOUNCEMENT

- This test report shall not be reproduced in full or partial, without the written approval of UL Japan, Inc.
- The results in this report apply only to the sample tested. (Laboratory was not involved in sampling.)
- This sample tested is in compliance with the limits of the above regulation.
- The test results in this test report are traceable to the national or international standards.
- This test report must not be used by the customer to claim product certification, approval, or endorsement by the A2LA accreditation body.
- This test report covers EMC technical requirements. It does not cover administrative issues such as Manual or non-EMC test related Requirements. (if applicable)
- The all test items in this test report are conducted by UL Japan, Inc. Ise EMC Lab.
- The opinions and the interpretations to the result of the description in this report are outside scopes where UL Japan, Inc. has been accredited.
- The information provided by the customer for this report is identified in SECTION 1.
- The laboratory is not responsible for information provided by the customer which can impact the validity of the results.
- For test report(s) referred in this report, the latest version (including any revisions) is always referred.

REVISION HISTORY

Original Test Report No. 15276765H

Revision	Test Report No.	Date	Page Revised Contents
- (Original)	15276765H	June 6, 2024	-

Reference: Abbreviations (Including words undescribed in this report)

A2LA	The American Association for Laboratory Accreditation	Hori.	Horizontal
AAN	Asymmetric Artificial Network	ICES	Interference-Causing Equipment Standard
AC	Alternating Current	I/O	Input/Output
AE	Auxiliary equipment	IEC	International Electrotechnical Commission
AM	Amplitude Modulation	IEEE	Institute of Electrical and Electronics Engineers
AMN	Artificial Mains Network	IF	Intermediate Frequency
Amp, AMP	Amplifier	ILAC	International Laboratory Accreditation Conference
ANSI	American National Standards Institute	ISED	Innovation, Science and Economic Development Canada
Ant, ANT	Antenna	ISN	Impedance Stabilization Network
AP	Access Point	ISO	International Organization for Standardization
ASK	Amplitude Shift Keying	JAB	Japan Accreditation Board
Atten., ATT	Attenuator	LAN	Local Area Network
AV	Average	LCL	Longitudinal Conversion Loss
BPSK	Binary Phase-Shift Keying	LIMS	Laboratory Information Management System
BR	Bluetooth Basic Rate	LISN	Line Impedance Stabilization Network
BT	Bluetooth	MRA	Mutual Recognition Arrangement
BT LE	Bluetooth Low Energy	N/A	Not Applicable
BW	BandWidth	NIST	National Institute of Standards and Technology
C.F	Correction Factor	NS	No signal detect.
Cal Int	Calibration Interval	NSA	Normalized Site Attenuation
CAV	CISPR AV	OBW	Occupied BandWidth
CCK	Complementary Code Keying	OFDM	Orthogonal Frequency Division Multiplexing
CDN	Coupling Decoupling Network	PER	Packet Error Rate
Ch., CH	Channel	PK	Peak
CISPR	Comite International Special des Perturbations Radioelectriques	P _{LT}	long-term flicker severity
Corr.	Correction	POHC(A)	Partial Odd Harmonic Current
CPE	Customer premise equipment	Pol., Pola.	Polarization
CW	Continuous Wave	PR-ASK	Phase Reversal ASK
DBPSK	Differential BPSK	P _{ST}	short-term flicker severity
DC	Direct Current	QAM	Quadrature Amplitude Modulation
DET	Detector	QP	Quasi-Peak
D-factor, D.fac.	Distance factor	QPSK	Quadrature Phase Shift Keying
Dmax	maximum absolute voltage change during an observation period	r.m.s., RMS	Root Mean Square
DQPSK	Differential QPSK	RBW	Resolution BandWidth
DSSS	Direct Sequence Spread Spectrum	RE	Radio Equipment
DUT	Device Under Test	REV	Reverse
EDR	Enhanced Data Rate	RF	Radio Frequency
e.i.r.p., EIRP	Equivalent Isotropically Radiated Power	RFID	Radio Frequency Identifier
EM clamp	Electromagnetic clamp	RNSS	Radio Navigation Satellite Service
EMC	ElectroMagnetic Compatibility	RSS	Radio Standards Specifications
EMI	ElectroMagnetic Interference	Rx	Receiving
EMS	ElectroMagnetic Susceptibility	S.fac.	Site factor
EN	European Norm	SINAD	Ratio of (Signal + Noise + Distortion) to (Noise + Distortion)
e.r.p., ERP	Effective Radiated Power	S/N	Signal to Noise ratio
ETSI	European Telecommunications Standards Institute	SA, S/A	Spectrum Analyzer
EU	European Union	SABS	South African Bureau of Standards
EUT	Equipment Under Test	SANS	South African National Standards
Fac.	Factor	SG	Signal Generator
FCC	Federal Communications Commission	SVSWR	Site-Voltage Standing Wave Ratio
FHSS	Frequency Hopping Spread Spectrum	THC(A)	Total Harmonic Current
FM	Frequency Modulation	THD(%)	Total Harmonic Distortion
Freq.	Frequency	TR, T/R	Test Receiver
FSK	Frequency Shift Keying	Tx	Transmitting
Fund	Fundamental	UFA	Uniform field area
FWD	Forward	VBW	Video BandWidth
GFSK	Gaussian Frequency-Shift Keying	Vert.	Vertical
GNSS	Global Navigation Satellite System	WLAN	Wireless LAN
GPS	Global Positioning System	xDSL	Generic term for all types of DSL technology (DSL: Digital Subscriber Line)

CONTENTS	PAGE
SECTION 1: Customer information	5
SECTION 2: Equipment under test (EUT)	5
SECTION 3: Test specification, procedures & results	6
SECTION 4: Operation of EUT during testing	9
SECTION 5: Radiated Emission	11
APPENDIX 1: Test data	13
Radiated Emission	13
APPENDIX 2: Test instruments	15
APPENDIX 3: Photographs of test setup	16
Radiated Emission	16
Worst Case Position	18

SECTION 1: Customer information

Company Name	ALPS ALPINE CO., LTD.
Address	6-3-36, Nakazato, Furukawa, Osaki-city, Miyagi-pref, 989-6181, Japan
Telephone Number	+81-229-23-5111
Contact Person	Yuji Ouchi

The information provided by the customer is as follows;

- Customer, Description of EUT, Model Number of EUT, FCC ID on the cover and other relevant pages
- Operating/Test Mode(s) (Mode(s)) on all the relevant pages
- SECTION 1: Customer Information
- SECTION 2: Equipment Under Test (EUT) other than the Receipt Date and Test Date
- SECTION 4: Operation of EUT during testing

SECTION 2: Equipment under test (EUT)

2.1 Identification of EUT

Description	TPMS/KEYLESS TUNER
Model Number	TD1G316
Serial Number	Refer to SECTION 4.2
Condition	Engineering prototype (Not for Sale: This sample is equivalent to mass-produced items.)
Modification	No Modification by the test lab
Receipt Date	May 10, 2024
Test Date	May 23, 2024

2.2 Product Description

General Specification

Rating	DC 12 V
Clock frequency (ies) in the system	16 MHz, 30.32 MHz

Radio Specification

Equipment Type	Receiver
Frequency of Operation	433.92 MHz
Type of Modulation	FSK
Oscillator Frequency	16 MHz (CPU), 30.32 MHz (RF IC)
Local Oscillator Frequency	1734.56 MHz
Intermediate Frequency	280 kHz
Type of receiving system	Super heterodyne

SECTION 3: Test specification, procedures & results

3.1 Test Specification

Test Specification	FCC Part 15 Subpart B The latest version on the first day of the testing period
Title	FCC 47CFR Part15 Radio Frequency Device Subpart B Unintentional Radiators

3.2 Procedures and results

Item	Test Procedure	Limits	Worst margin	Result	Remarks
Conducted emission	FCC: ANSI C63.4: 2014 + C63.4a: 2017 7. AC power - line conducted emission measurements ISED: RSS-Gen 7.1	FCC: Part 15 Subpart B 15.107(a) ISED: RSS-Gen 7.2	-	N/A	*1)
Radiated emission	FCC: ANSI C63.4: 2014 + C63.4a: 2017 8. Radiated emission measurements ISED: RSS-Gen 7.1	FCC: Part 15 Subpart B 15.109(a) ISED: RSS-Gen 7.3	23.43 dB 30.320 MHz, Horizontal, QP	Complied	-
Antenna Terminal	FCC: ANSI C63.4: 2014 + C63.4a: 2017 12. Measurement of unintentional radiators other than ITE ISED: RSS-Gen 7.1	FCC: Part 15 Subpart B 15.111(a) ISED: RSS-Gen 7.4	-	N/A	*2)
<p>* Note: UL Japan, Inc.'s EMI Work Procedure: Work Instructions-ULID-003591. *1) The test is not applicable since the EUT is not the device that is designed to be connected to the public utility (AC) power line. *2) The receiving antenna (of this EUT) is installed inside the EUT and cannot be removed (permanently attached). Therefore, Radiated emission test was performed.</p>					

3.3 Addition to standard

No addition, exclusion nor deviation has been made from the standard.

3.4 Uncertainty

Measurement uncertainty is not taken into account when stating conformity with a specified requirement. Note: When margins obtained from test results are less than the measurement uncertainty, the test results may exceed the limit.

The following uncertainties have been calculated to provide a confidence level of 95 % using a coverage factor $k = 2$.

Radiated emission

Measurement distance	Frequency range		Unit	Calculated Uncertainty (+/-)
3 m	9 kHz to 30 MHz		dB	3.3
10 m			dB	3.1
3 m	30 MHz to 200 MHz	Horizontal	dB	4.7
		Vertical	dB	4.7
	200 MHz to 1000 MHz	Horizontal	dB	4.8
		Vertical	dB	6.0
10 m	30 MHz to 200 MHz	Horizontal	dB	5.2
		Vertical	dB	5.1
	200 MHz to 1000 MHz	Horizontal	dB	5.2
		Vertical	dB	5.2
3 m	1 GHz to 6 GHz		dB	5.0
	6 GHz to 18 GHz		dB	5.2
1 m	10 GHz to 18 GHz		dB	5.3
	18 GHz to 26.5 GHz		dB	5.2
	26.5 GHz to 40 GHz		dB	4.7
0.5 m	26.5 GHz to 40 GHz		dB	4.8

3.5 Test Location

UL Japan, Inc. Ise EMC Lab.

4383-326 Asama-cho, Ise-shi, Mie-ken 516-0021 Japan

Telephone: +81-596-24-8999

A2LA Certificate Number: 5107.02 / FCC Test Firm Registration Number: 884919

ISED Lab Company Number: 2973C / CAB identifier: JP0002

Test site	Width x Depth x Height (m)	Size of reference ground plane (m) / horizontal conducting plane	Other rooms	Maximum measurement distance
No.1 semi-anechoic chamber	19.2 x 11.2 x 7.7	7.0 x 6.0	No.1 Power source room	10 m
No.2 semi-anechoic chamber	7.5 x 5.8 x 5.2	4.0 x 4.0	-	3 m
No.3 semi-anechoic chamber	12.0 x 8.5 x 5.9	6.8 x 5.75	No.3 Preparation room	3 m
No.3 shielded room	4.0 x 6.0 x 2.7	N/A	-	-
No.4 semi-anechoic chamber	12.0 x 8.5 x 5.9	6.8 x 5.75	No.4 Preparation room	3 m
No.4 shielded room	4.0 x 6.0 x 2.7	N/A	-	-
No.5 semi-anechoic chamber	6.0 x 6.0 x 3.9	6.0 x 6.0	-	-
No.5 measurement room	6.4 x 6.4 x 3.0	6.4 x 6.4	-	-
No.6 shielded room	4.0 x 4.5 x 2.7	4.0 x 4.5	-	-
No.6 measurement room	4.75 x 5.4 x 3.0	4.75 x 4.15	-	-
No.7 shielded room	4.7 x 7.5 x 2.7	4.7 x 7.5	-	-
No.8 measurement room	3.1 x 5.0 x 2.7	3.1 x 5.0	-	-
No.9 measurement room	8.8 x 4.6 x 2.8	2.4 x 2.4	-	-
No.10 shielded room	3.8 x 2.8 x 2.8	3.8 x 2.8	-	-
No.11 measurement room	4.0 x 3.4 x 2.5	N/A	-	-
No.12 measurement room	2.6 x 3.4 x 2.5	N/A	-	-
Large Chamber	16.9 x 22.1 x 10.17	16.9 x 22.1	-	10 m
Small Chamber	5.3 x 6.69 x 3.59	5.3 x 6.69	-	-

3.6 Test data, Test instruments, and Test set up

Refer to APPENDIX.

SECTION 4: Operation of EUT during testing

4.1 Operating Mode(s)

Mode	1. Receiving mode
Software(s)	5AB-01621A

*The test signal level was confirmed to be sufficient to stabilize the local oscillator of the EUT.
* It was confirmed by using checker that the EUT receives the signal from the transmitter (pair of EUT).

4.2 Configuration and peripherals

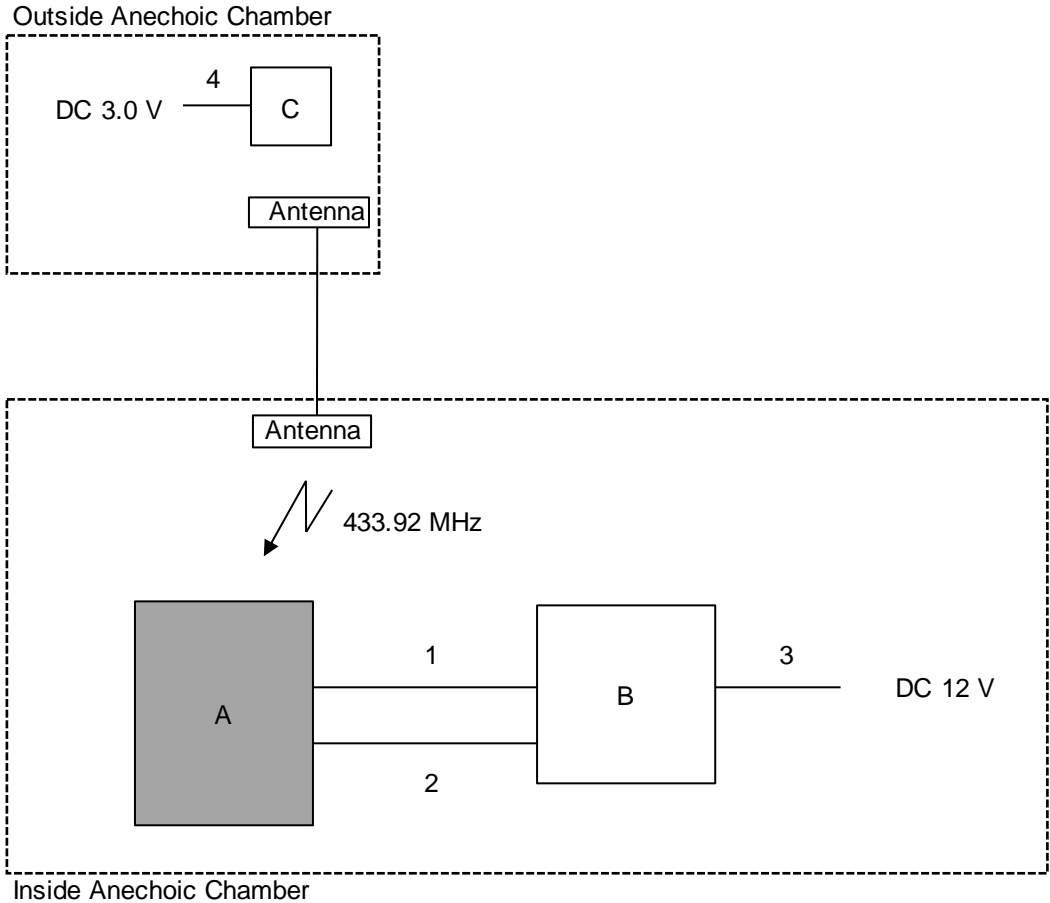

* Cabling and setup(s) were taken into consideration and test data was taken under worse case conditions.
* Item No. A includes Receiver Antenna.

Description of EUT and Support Equipment

No.	Item	Model number	Serial Number	Manufacturer	Remarks
A	TPMS/KEYLESS TUNER	TD1G316	No.24050901	ALPS ALPINE CO., LTD.	EUT
B	SW Checker BOX	-	No.7	ALPS ALPINE CO., LTD.	-
C	TPMS DUMMY TRANSMITTER	TB1G496	No.24050902	ALPS ALPINE CO., LTD.	-

List of Cables Used

No.	Name	Length (m)	Shield		Remarks
			Cable	Connector	
1	DC Cable	1.0	Unshielded	Unshielded	-
2	Signal Cable	1.0	Unshielded	Unshielded	-
3	DC Cable	0.2	Unshielded	Unshielded	-
4	DC Cable	0.2	Unshielded	Unshielded	-

SECTION 5: Radiated Emission

5.1 Operating environment

Date : See data
Test place : See data
Temperature : See data
Humidity : See data
Test engineer : See data

5.2 Test configuration

EUT was placed on a urethane platform of nominal size, 1.0 m by 1.5 m, raised 0.8 m above the conducting ground plane.

The EUT was set on the edge of the tabletop.

Test was made with the antenna positioned in both the horizontal and vertical planes of polarization. The measurement antenna was varied in height above the conducting ground plane to obtain the maximum signal strength.

Photographs of the set up are shown in APPENDIX 3.

5.3 Test conditions

Frequency range : 30 MHz to 200 MHz (Biconical antenna)
200 MHz to 1000 MHz (Logperiodic antenna)
1000 MHz to 10000 MHz (Horn antenna)
Test distance : 3 m
EUT position : Table top
EUT operation mode : See Clause 4.1

5.4 Test procedure

The height of the measuring antenna varied between 1 and 4 m and EUT was rotated a full revolution in order to obtain the maximum value of the electric field intensity.

The measurements were performed for both vertical and horizontal antenna polarization with the Test Receiver.

The radiated emission measurements were made with the following detector function of the Test Receiver. Test antenna was aimed at the emission source for receiving the maximum signal and always kept. (Above 1 GHz)

Frequency	Below 1 GHz	Above 1 GHz *1)
Instrument used	Test Receiver	Test Receiver
IF Bandwidth	QP: BW 120 kHz	PK: BW 1 MHz, CAV: BW 1 MHz

*1) The measurement data was adjusted to a 3 m distance using the following Distance Factor.
Distance Factor: See Figure 1.

Figure 2: Test Setup

Below 1 GHz

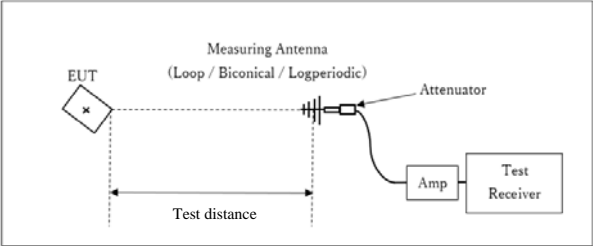

* : Center of turn table

Test Distance: 3 m

1 GHz to 10 GHz

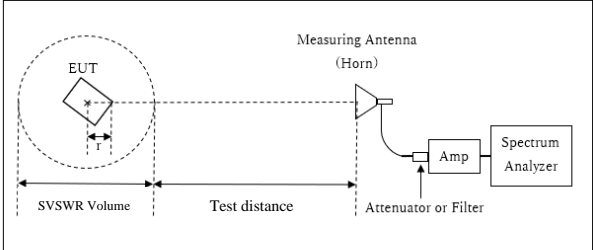

r : Radius of an outer periphery of EUT
 * : Center of turn table

Test Distance: 3 m

[1 GHz to 6 GHz]
 Distance Factor: $20 \times \log(3.75 \text{ m}^*/3.0 \text{ m}) = 1.94 \text{ dB}$
 *Test Distance: $(3 + \text{SVSWR Volume} / 2) - r = 3.75 \text{ m}$

[6 GHz to 10 GHz]
 Distance Factor: $20 \times \log(4.75 \text{ m}^*/3.0 \text{ m}) = 4.00 \text{ dB}$
 *Test Distance: $(4.3 + \text{SVSWR Volume} / 2) - r = 4.75 \text{ m}$

SVSWR Volume: 2.0 m [1 - 6 GHz]
 SVSWR Volume: 1.4 m [6 - 10 GHz]
 (SVSWR Volume has been calibrated based on CISPR 16-1-4.)

$r = 0.25 \text{ m}$

The noise levels were confirmed at each position of X, Y and Z axes of EUT to see the position of maximum noise, and the test was made at representative X-axis since no difference was found among each position.

5.5 Test result

Summary of the test results: Pass

Test results are rounded off and limit are rounded down, so some differences might be observed.

APPENDIX 1: Test data

Radiated Emission

Test place Ise EMC Lab.
Semi Anechoic Chamber No.3
Date May 23, 2024
Temperature / Humidity 23 deg. C / 53 % RH
Engineer Tetsuro Yoshida
(Below 1 GHz)
Mode Mode 1

Limit : FCC_Part 15 Subpart B(15.109)_Class B

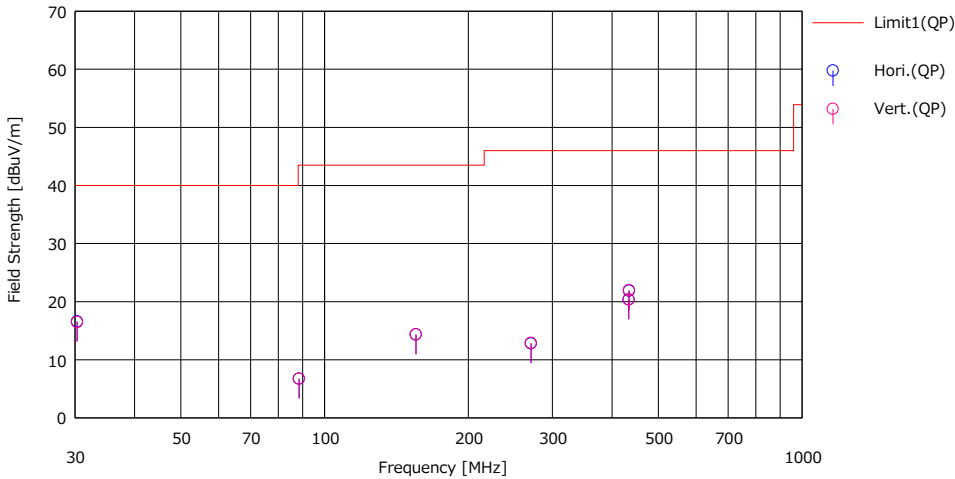

No.	Freq. [MHz]	Reading	Ant.Fac	Loss	Gain	Result	Limit	Margin	Pola.	Height	Angle	Ant. Type	Comment
		[dBuV]				[dBuV/m]	[dB]	[dB]					
1	30.320	23.40	18.47	6.91	32.21	16.57	40.00	23.43	Hori.	100	0	BA	
2	88.424	23.00	8.13	7.76	32.16	6.73	43.50	36.77	Hori.	100	0	BA	
3	155.345	22.80	15.16	8.47	32.09	14.34	43.50	29.16	Hori.	100	0	BA	
4	270.583	22.50	12.86	9.44	32.01	12.79	46.00	33.21	Hori.	100	0	LA22	
5	433.640	25.60	16.23	10.54	32.02	20.35	46.00	25.65	Hori.	100	0	LA22	
6	434.200	27.10	16.24	10.54	32.02	21.86	46.00	24.14	Hori.	100	0	LA22	
7	30.320	23.30	18.47	6.91	32.21	16.47	40.00	23.53	Vert.	100	0	BA	
8	88.424	23.00	8.13	7.76	32.16	6.73	43.50	36.77	Vert.	100	0	BA	
9	155.345	22.80	15.16	8.47	32.09	14.34	43.50	29.16	Vert.	100	0	BA	
10	270.583	22.60	12.86	9.44	32.01	12.89	46.00	33.11	Vert.	100	0	LA22	
11	433.640	25.60	16.23	10.54	32.02	20.35	46.00	25.65	Vert.	100	0	LA22	
12	434.200	27.20	16.24	10.54	32.02	21.96	46.00	24.04	Vert.	100	0	LA22	

CHART: WITH FACTOR
 ANT TYPE: - 30 MHz: LOOP, 30 MHz - 200 MHz: BICONICAL, 200 MHz - 1000 MHz: LOGPERIODIC, 1000 MHz -: HORN
 CALCULATION: RESULT = READING + ANT FACTOR + LOSS(CABLE + ATT) - GAIN(AMP)
 Except for the above table: adequate margin data below the limits.

Radiated Emission

Test place	Ise EMC Lab.
Semi Anechoic Chamber	No.3
Date	May 23, 2024
Temperature / Humidity	23 deg. C / 53 % RH
Engineer	Tetsuro Yoshida
	(Above 1 GHz)
Mode	Mode 1

Limit : FCC_Part 15 Subpart B(15.109)_Class B

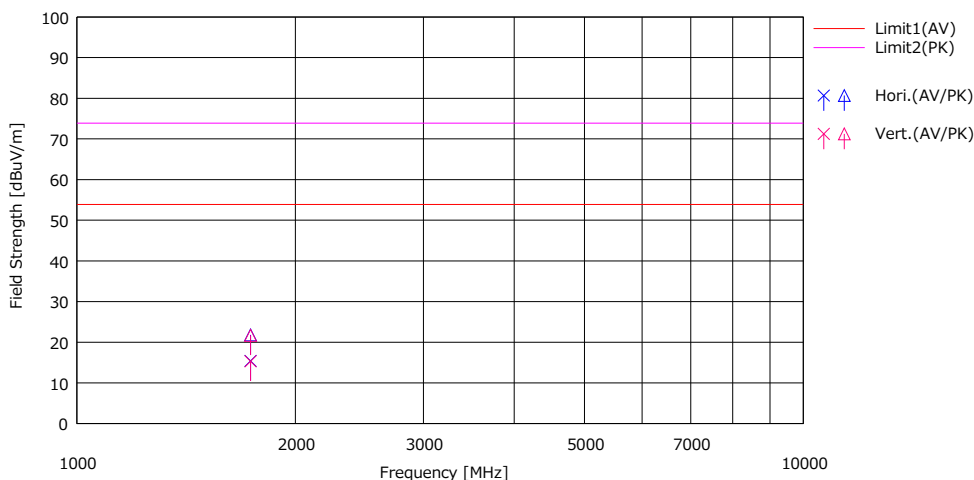

No.	Freq. [MHz]	Reading		Ant.Fac [dB/m]	Loss [dB]	Gain [dB]	Result		Limit		Margin		Pola. [H/V]	Height [cm]	Angle [deg]	Ant. Type	Comment
		(AV) [dBuV]	(PK) [dBuV]				(AV) [dBuV/m]	(PK) [dBuV/m]	(AV) [dB]	(PK) [dB]							
1	1734.500	21.20	27.60	24.92	2.27	33.00	15.39	21.79	53.90	73.90	38.51	52.11	Hori.	100	0	H20	
2	1734.500	21.10	27.50	24.92	2.27	33.00	15.29	21.69	53.90	73.90	38.61	52.21	Vert.	100	0	H20	

CHART: WITH FACTOR

ANT TYPE: - 30 MHz: LOOP, 30 MHz - 200 MHz: BICONICAL, 200 MHz - 1000 MHz: LOGPERIODIC, 1000 MHz -: HORN

CALCULATION: RESULT = READING + ANT FACTOR + LOSS(CABLE + D-factor) - GAIN(AMP)

Except for the above table: adequate margin data below the limits.

APPENDIX 2: Test instruments

Test equipment

Test Item	LIMS ID	Description	Manufacturer	Model	Serial	Last Calibration Date	Cal Int
RE	141266	Logperiodic Antenna (200-1000MHz)	Schwarzbeck Mess-Elektronik OHG	VUSLP9111B	9111B-191	08/10/2023	12
RE	141323	Coaxial cable	UL Japan	-	-	09/10/2023	12
RE	141393	Microwave Cable	Junkosha	MWX221	1604S254(1 m) / 1608S088(5 m)	08/01/2023	12
RE	141424	Biconical Antenna	Schwarzbeck Mess-Elektronik OHG	VHA9103+BBA9106	1915	03/15/2024	12
RE	141507	Horn Antenna 1-18GHz	Schwarzbeck Mess-Elektronik OHG	BBHA9120D	258	11/20/2023	12
RE	141532	DIGITAL HiTESTER	HIOKI E.E. CORPORATION	3805	051201197	01/31/2024	12
RE	141580	MicroWave System Amplifier	Keysight Technologies Inc	83017A	MY39500779	03/08/2024	12
RE	141582	Pre Amplifier	SONOMA INSTRUMENT	310	260834	02/17/2024	12
RE	141950	EMI Test Receiver	Rohde & Schwarz	ESU26	100412	11/20/2023	12
RE	142008	AC3_Semi Anechoic Chamber(NSA)	TDK	Semi Anechoic Chamber 3m	DA-10005	12/11/2023	24
RE	142013	AC3_Semi Anechoic Chamber(SVSWR)	TDK	Semi Anechoic Chamber 3m	DA-10005	10/18/2023	12
RE	142183	Measure	KOMELON	KMC-36	-	10/20/2023	12
RE	142314	Attenuator	Pasternack Enterprises	PE7390-6	D/C 1504	06/23/2023	12
RE	178648	EMI measurement program	TSJ (Techno Science Japan)	TEPTO-DV	-	-	-
RE	244709	Thermo-Hygrometer	HIOKI E.E. CORPORATION	LR5001	231202103	01/25/2024	12
RE	245787	Double Ridge Horn Antenna	Schwarzbeck Mess-Elektronik OHG	BBHA 9120 C	689	03/06/2024	12

*Hyphens for Last Calibration Date and Cal Int (month) are instruments that Calibration is not required (e.g. software), or instruments checked in advance before use.

The expiration date of the calibration is the end of the expired month.

As for some calibrations performed after the tested dates, those test equipment have been controlled by means of an unbroken chains of calibrations.

All equipment is calibrated with valid calibrations. Each measurement data is traceable to the national or international standards.

Test item:

RE: Radiated emission