

Technical Document for Type Approval

For Smart Key FOB

TYPE: FD01240

| <u>Details of contents</u> | <u>Page</u> |
|---|-------------|
| 1. Description of manufacture | 2 |
| 2. Technical description of Smart Key FOB | 3 |
| 3. Outline of Smart Key FOB | 4 |

1. Description of manufacturer

1.1 Trade mark

: N/A

1.2 Name and address of manufacturer

-Name : DENSO KOREA CORPORATION

-Address : 3, Cheomdansaneop-ro, Masanhappo-gu, Changwon-si,
Gyungsoangnam-do, Korea

1.3 Name and address of applicant

-Name : DENSO KOREA CORPORATION

-Address : 3, Cheomdansaneop-ro, Masanhappo-gu, Changwon-si,
Gyungsoangnam-do, Korea

2. Technical description of Smart Key FOB

2.1. Type

- Model : FD01240

2.2. Specifications of Electronic Key

- Nominal frequency : 433.92MHz
- Oscillator frequency (IC clock) : 16MHz
- Oscillator frequency (RF clock) : 27.6MHz
- Type of modulation : FSK/F1D
- Power Supply
 - Nominal supply voltage : 3 VDC
 - Type of Battery : One lithium battery
- Antenna : Built-in type (Fixed)

3. Outline of Smart Key FOB

Smart Key FOB is mainly used for locking or unlocking the doors of the vehicles. Smart Key FOB detects signals when it reaches the vicinity of vehicle, and sends signals using radio frequency.

Also, Smart Key FOB sends a radio wave signal while a button is pushed. When the button is released, the radio wave signal is automatically off within 0.196 seconds. When the button is depressed continuously, Smart Key FOB sends a signal for a predetermined constant time.

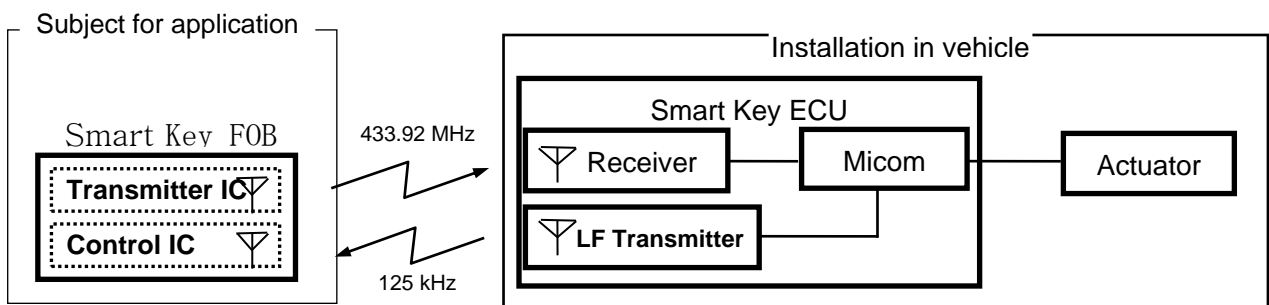

This product sends a signal when the following buttons are pushed.

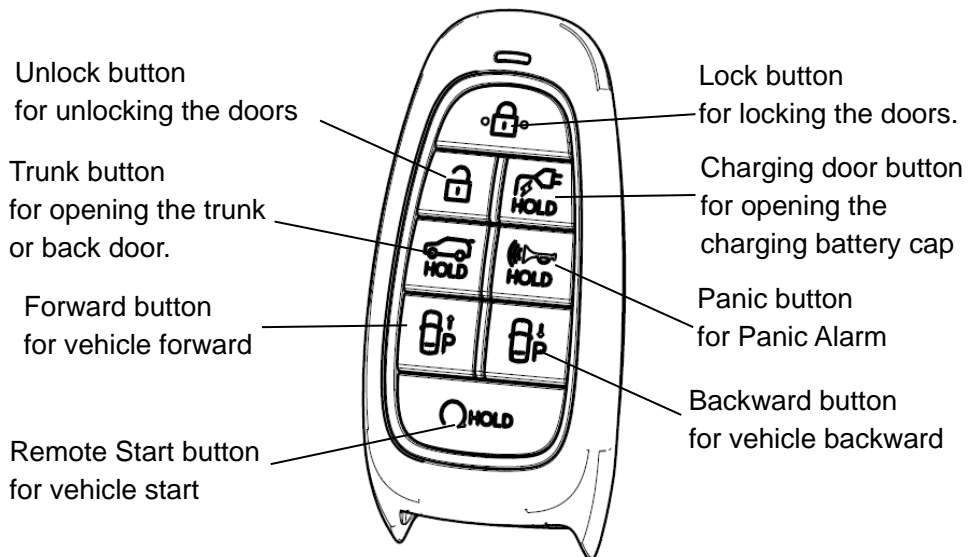

FCC Part 15.19

This device complies with part 15 of the FCC Rules. Operation is subject to the following two conditions: (1) This device may not cause harmful interference, and (2) this device must accept any interference received, including interference that may cause undesired operation.

FCC Part 15.21

Any changes or modifications (including the antennas) to this device that are not expressly approved by the manufacturer may void the user's authority to operate the equipment.

FCC and IC RF Radiation Exposure Statement: This equipment complies with FCC and IC RF Radiation exposure limits set forth for an uncontrolled environment.

This device and its antenna must not be co-located or operating in conjunction with any other antenna or transmitter.

This device contains licence-exempt transmitter(s)/receiver(s) that comply with Innovation, Science and Economic Development Canada's licence-exempt RSS(s). Operation is subject to the following two conditions:

- (1) This device may not cause interference.
- (2) This device must accept any interference, including interference that may cause undesired operation of the device.

L'émetteur/récepteur exempt de licence contenu dans le présent appareil est conforme aux CNR d'Innovation, Sciences et Développement économique Canada applicables aux appareils radio exempts de licence. L'exploitation est autorisée aux deux conditions suivantes :

- (1) L'appareil ne doit pas produire de brouillage;
- (2) L'appareil doit accepter tout brouillage radioélectrique subi, même si le brouillage est susceptible d'en compromettre le fonctionnement.

RF du FCC et IC d'exposition aux radiations: Cet équipement est conforme à l'exposition de FCC et IC rayonnements RF limites établies pour un environnement non contrôlé.

L'antenne pour ce transmetteur ne doit pas être au même endroit avec d'autres émetteur sauf conformément à FCC et IC procédures de produits Multi-émetteur.