

3. Outline of Smart Key FOB

Smart Key FOB is mainly used for locking or unlocking the doors of the vehicles. Smart Key FOB detects signals when it reaches the vicinity of vehicle, and sends signals using radio frequency.

Also, Smart Key FOB sends a radio wave signal while a button is pushed. When the button is released, the radio wave signal is automatically off within 0.392 seconds. When the button is depressed continuously, Smart Key FOB sends a signal for a predetermined constant time.

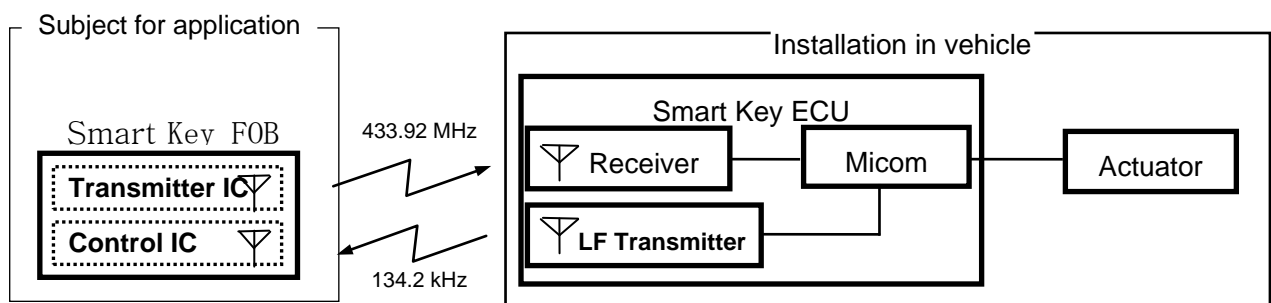

This product sends a signal when the following buttons are pushed.

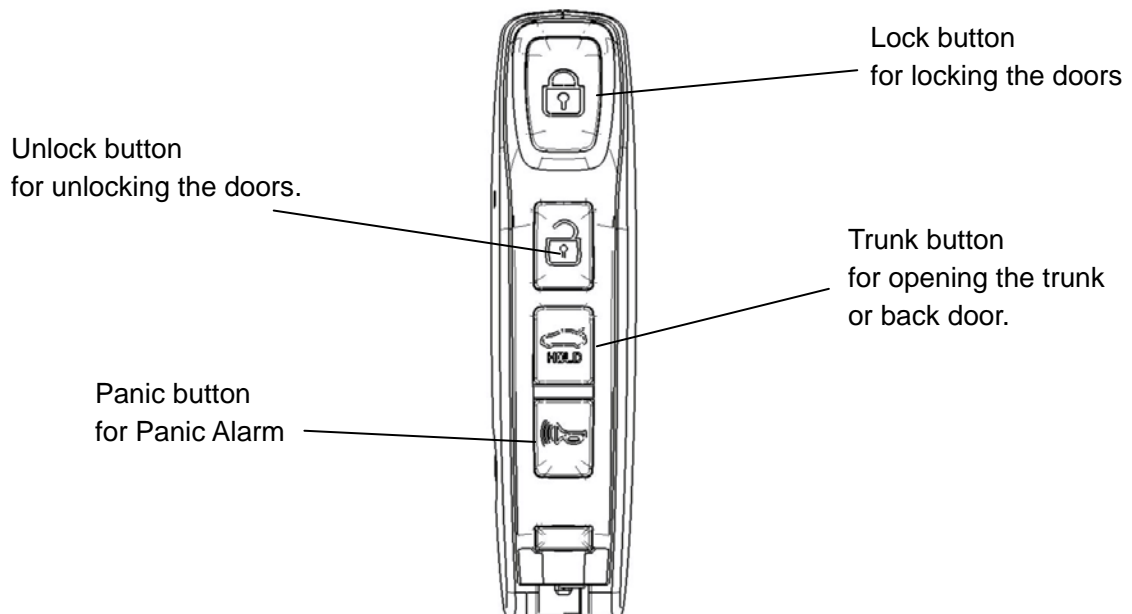

FCC Warning Statement

FCC Part 15.19

This device complies with part 15 of the FCC Rules. Operation is subject to the following two conditions: (1) this device may not cause harmful interference, and (2) this device must accept any interference received, including interference that may cause undesired operation.

FCC Part 15.21

Any changes or modifications (including the antennas) to this device that are not expressly approved by the manufacturer may void the user's authority to operate the equipment.

Industry Canada Statement:

This device complies with Industry Canada licence-exempt RSS standard(s).

Operation is subject to the following two conditions:

(1) this device may not cause interference, and (2) this device must accept any interference, including interference that may cause undesired operation of the device.

Le présent appareil est conforme aux CNR d'Industrie Canada applicables aux appareils radio exempts de licence.

L'exploitation est autorisée aux deux conditions suivantes :

(1) l'appareil ne doit pas produire de brouillage, et (2) l'utilisateur de l'appareil doit accepter tout brouillage radioélectrique subi, même si le brouillage est susceptible d'en compromettre le fonctionnement.