

DENSO KOREA CORPORATION  
OCT, 10, 2019

1. Description of manufacturer

1.1 Trade mark

: DNKR

1.2 Name and address of manufacturer

-Name : DENSO KOREA CORPORATION  
-Address : Cheomdan Industry 3, Masanhappo-gu, Changwon-si,  
Gyungsoangnam-do, Korea

1.3 Name and address of applicant

-Name : DENSO KOREA CORPORATION  
-Address : Cheomdan Industry 3, Masanhappo-gu, Changwon-si,  
Gyungsoangnam-do, Korea

## 2. Technical description of the system

### 2.1 Type number

-Smart Key ECU : EG09980

### 2.2 Specifications

- Nominal Power supply voltage : 12VDC

#### Receiver(RF)

-Nominal frequency : 433.92MHz  
-Oscillator frequency : 21.948717MHz (Crystal)  
-Type of modulation : FSK(F1D)  
-Type of receiving system : Super-heterodyne  
-Antenna : RF ANT : Internal antenna

#### Transponder

-Nominal frequency : 134.2kHz  
-Oscillator frequency : 4.00MHz (Resonator)  
-Type of modulation : OOK(A1D)  
-Antenna : TP ANT: External antenna (Built in SSB)

### 3. Outline of the system

Directly and indirectly controls various Indicator, Side mirror and Relay control related to existing BCM function, controls start of vehicle when authentication of RKE key is successful, and performs warning and notation processing of data received from TPS sensor.

#### 3.1. IBU NSMK

BCM function is a function for user convenience / warning, and it can directly or indirectly control various indicators, sensor power, hot wire and relay control through communication or switch input. It also performs Immobilizer function.

- Terminal control function: IGN1, IGN2, ACC power control
- Immobilizer function: Perform function for RKE Key authentication
- Head lamp washer relay control function - Optional function
- Indicator control function
- Auto light control function
- Puddle & Pocket Lamp control function
- Solenoid control function (ATM)
- PAS power control function
- LIN communication
- Chassis CAN communication (500kbps)
- Body CAN communication (500kbps)

#### 3.2 Transponder Antenna:

Built in the Start Stop Button to communicate with the transponder by a base station and using wireless communication :(134.2kHz)

### 3.3 Installation in vehicle

The NSMK ECU is installed inside the vehicle.

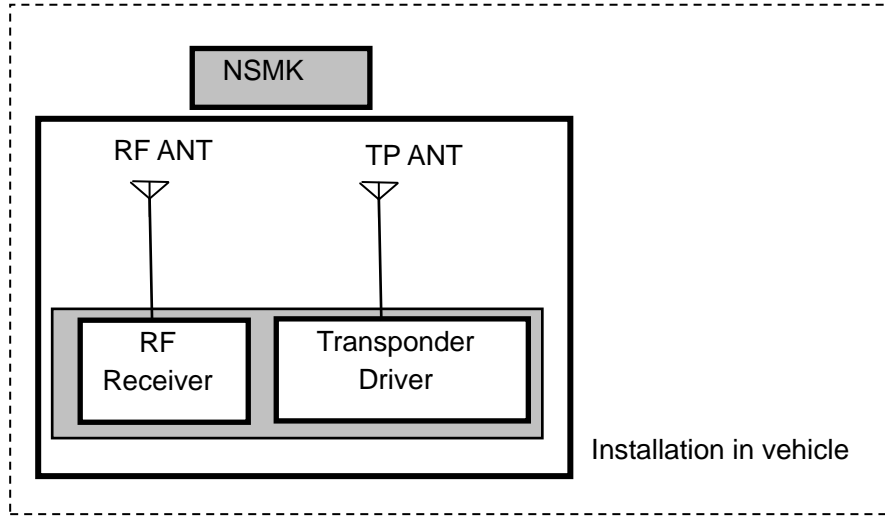

Fig. Outline of the System

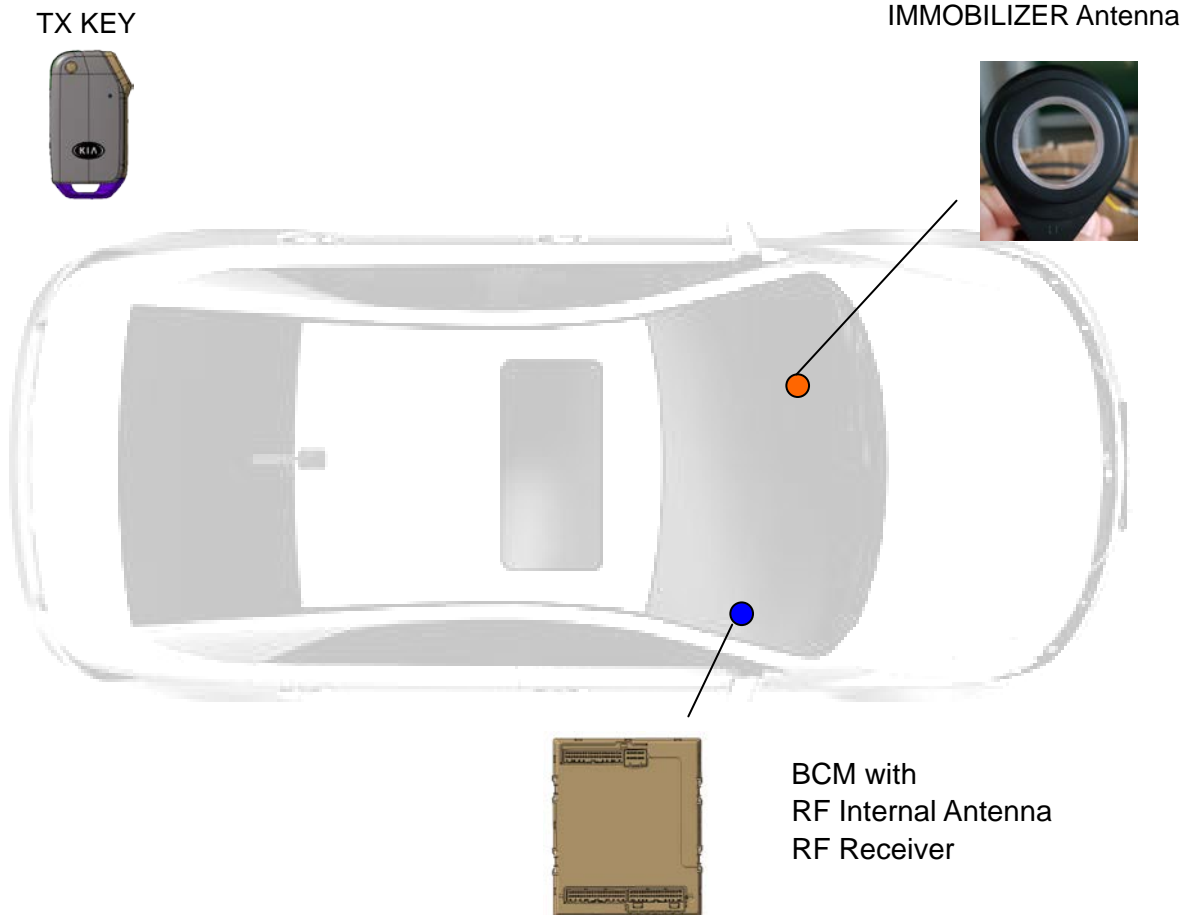

Fig. Installation of the System

FCC Part 15.19

This device complies with part 15 of the FCC Rules. Operation is subject to the following two conditions: (1) This device may not cause harmful interference, and (2) this device must accept any interference received, including interference that may cause undesired operation.

FCC Part 15.21

Any changes or modifications (including the antennas) to this device that are not expressly approved by the manufacturer may void the user's authority to operate the equipment.

FCC and IC RF Radiation Exposure Statement: This equipment complies with FCC and IC RF Radiation exposure limits set forth for an uncontrolled environment.

This device and its antenna must not be co-located or operating in conjunction with any other antenna or transmitter.

This device contains licence-exempt transmitter(s)/receiver(s) that comply with Innovation, Science and Economic Development Canada's licence-exempt RSS(s). Operation is subject to the following two conditions:

- (1) This device may not cause interference.
- (2) This device must accept any interference, including interference that may cause undesired operation of the device.

L'émetteur/récepteur exempt de licence contenu dans le présent appareil est conforme aux CNR d'Innovation, Sciences et Développement économique Canada applicables aux appareils radio exempts de licence. L'exploitation est autorisée aux deux conditions suivantes :

- (1) L'appareil ne doit pas produire de brouillage;
- (2) L'appareil doit accepter tout brouillage radioélectrique subi, même si le brouillage est susceptible d'en compromettre le fonctionnement.

RF du FCC et IC d'exposition aux radiations: Cet équipement est conforme à l'exposition de FCC et IC rayonnements RF limites établies pour un environnement non contrôlé.

L'antenne pour ce transmetteur ne doit pas être même endroit avec d'autres émetteur sauf conformément à FCC et IC procédures de produits Multi-émetteur.