

DENSO KOREA CORPORATION  
OCT, 10, 2019

1. Description of manufacturer

1.1 Trade mark

: DNKR

1.2 Name and address of manufacturer

-Name : DENSO KOREA CORPORATION  
-Address : Cheomdan Industry 3, Masanhappo-gu, Changwon-si,  
Gyungsoangnam-do, Korea

1.3 Name and address of applicant

-Name : DENSO KOREA CORPORATION  
-Address : Cheomdan Industry 3, Masanhappo-gu, Changwon-si,  
Gyungsoangnam-do, Korea

## 2. Technical description of the system

### 2.1 Type number

-Smart Key ECU : EG08220

### 2.2 Specifications

- Nominal Power supply voltage : 12VDC

#### Receiver(RF)

-Nominal frequency : 433.92MHz  
-Oscillator frequency : 21.948717MHz (Crystal)  
-Type of modulation : FSK(F1D)  
-Type of receiving system : Super-heterodyne  
-Antenna : RF ANT : Internal antenna

#### Transmitter(LF)

-Nominal frequency : 125kHz  
-Oscillator frequency : 4.026 MHz (Crystal)  
-Type of modulation : OOK(A1D)  
-Antenna : LF ANT1: External antenna (inside Cabin)  
LF ANT2: External antenna (inside Cabin)  
LF ANT3: External antenna (inside Trunk)  
LF ANT4: External antenna (inside Bumper)  
LF ANT5: External antenna (inside Bumper)  
LF ANT6: External antenna (Built in Door HDL)  
LF ANT7: External antenna (Built in Door HDL)

#### Transponder

-Nominal frequency : 125kHz  
-Oscillator frequency : 4.00MHz (Resonator)  
-Type of modulation : OOK(A1D)  
-Antenna : TP ANT: External antenna (Built in SSB)

### 3. Outline of the system

Existing BCM, SMK, TPMS receiver integrated ECU as well as smart key function. Body and TPMS related control unit (integrated PDM, RF Receiver). It controls the power operation mode (ACC, IGN1, IGN2, START) of the vehicle according to the operation of the START / STOP button when the card key / FOB is successfully authenticated. Various Lamp, Indicator, Rear Curtain, Side mirror, Relay control related to BCM function Directly and indirectly, and performs a warning and display function for processing data received from the TPS sensor.

#### 3.1. IBU RSPA

##### Smart Key System

The smart key unit controls the smart key system. When the user inputs the door handle or the start button, the smart key unit transmits the LF signal (125KHz) to the smart key FOB and receives the signal (433 MHz) from the FOB to perform a related function .

- Terminal control function: Control terminal (IGN1, IGN2, ACC) power when inputting start / stop button
- Immobilizer function: Function for emergency start or RKE key authentication when discharging FOB battery
- Start stop button LED lighting control
- Electrical steering column lock (ESCL) control function - excluding domestic / North American / Canadian specifications

##### BCM function System

BCM function is a function for user convenience / warning, and it can directly or indirectly control various indicators, sensor power, hot wire and relay control through communication or switch input. It also performs Immobilizer function.

- Terminal control function: IGN1, IGN2, ACC power control
- Immobilizer function: Perform function for RKE Key authentication
- Head lamp washer relay control function - Optional function
- Indicator control function
- Auto light control function
- Puddle & Pocket Lamp control function
- Solenoid control function (ATM)
- PAS power control function

- LIN communication
- Chassis CAN communication (500kbps)
- Body CAN communication (500kbps)

### 3.2. LF Antennas:

Inductive antennas in and at the vehicle are used to transform the current, driven by the SMK antenna driver, into a magnetic field (125 kHz), which is the carrier for the SMK challenge.

Two antenna covers the vehicle's interior. One antenna covers the interior of the Trunk. Two antennas in the Door Handles (Left side and Right side) cover the area around the doors. One antenna in the rear bumper covers the area around the trunk for access to the trunk. Those antennas are based on ferrite core and have a pair of twisted copper cables from antenna to pin header.

### 3.3. Transponder Antenna:

Built in the Start Stop Button to communicate with the transponder by a base station and using wireless communication :(125 kHz)

### 3.4 Installation in vehicle

The Smart Key ECU is installed inside the vehicle.

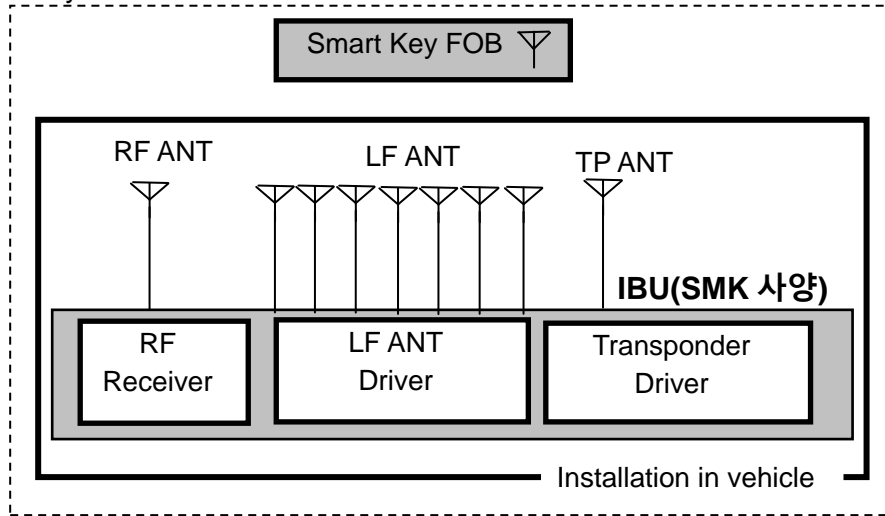

Fig. Outline of the System

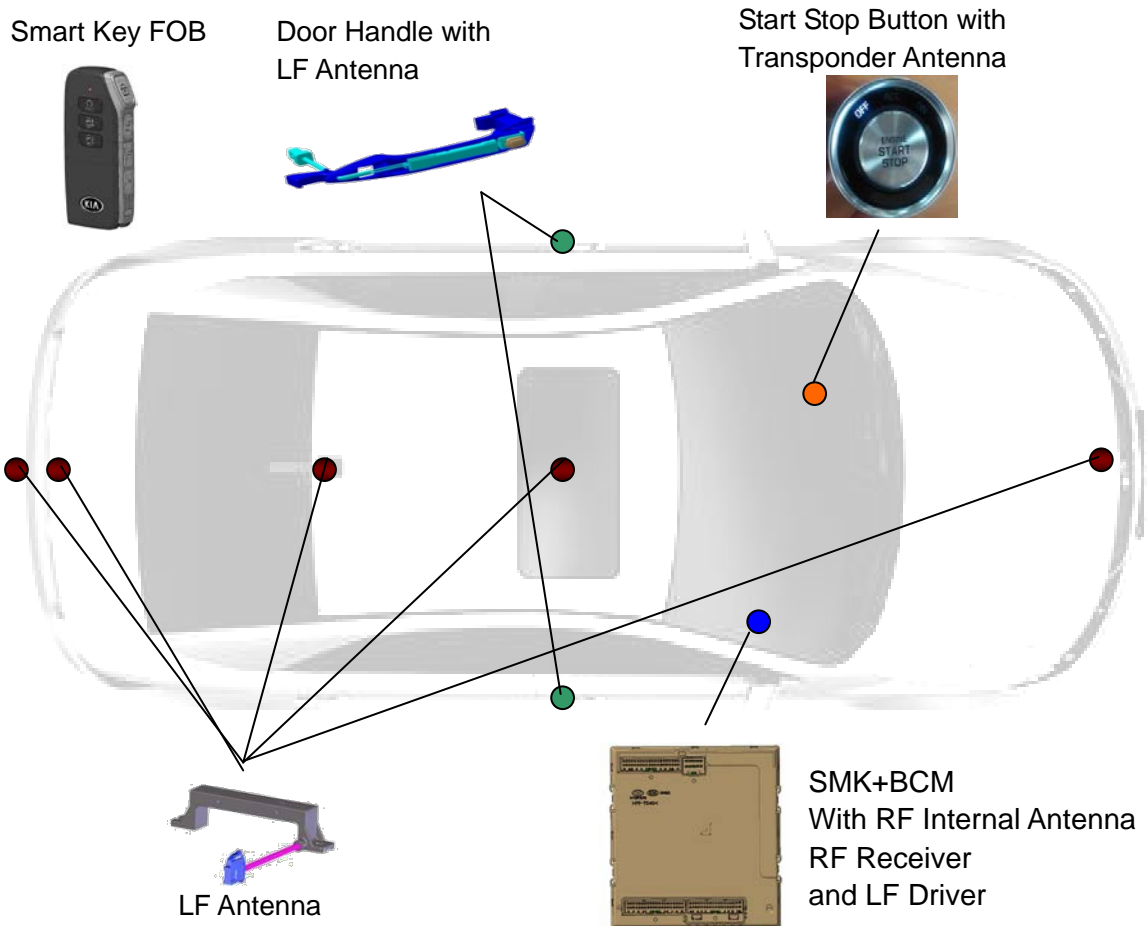

Fig. Installation of the System

FCC Part 15.19

This device complies with part 15 of the FCC Rules. Operation is subject to the following two conditions: (1) This device may not cause harmful interference, and (2) this device must accept any interference received, including interference that may cause undesired operation.

FCC Part 15.21

Any changes or modifications (including the antennas) to this device that are not expressly approved by the manufacturer may void the user's authority to operate the equipment.

FCC and IC RF Radiation Exposure Statement: This equipment complies with FCC and IC RF Radiation exposure limits set forth for an uncontrolled environment.

This device and its antenna must not be co-located or operating in conjunction with any other antenna or transmitter.

This device contains licence-exempt transmitter(s)/receiver(s) that comply with Innovation, Science and Economic Development Canada's licence-exempt RSS(s). Operation is subject to the following two conditions:

- (1) This device may not cause interference.
- (2) This device must accept any interference, including interference that may cause undesired operation of the device.

L'émetteur/récepteur exempt de licence contenu dans le présent appareil est conforme aux CNR d'Innovation, Sciences et Développement économique Canada applicables aux appareils radio exempts de licence. L'exploitation est autorisée aux deux conditions suivantes :

- (1) L'appareil ne doit pas produire de brouillage;
- (2) L'appareil doit accepter tout brouillage radioélectrique subi, même si le brouillage est susceptible d'en compromettre le fonctionnement.

RF du FCC et IC d'exposition aux radiations: Cet équipement est conforme à l'exposition de FCC et IC rayonnements RF limites établies pour un environnement non contrôlé.

L'antenne pour ce transmetteur ne doit pas être au même endroit avec d'autres émetteur sauf conformément à FCC et IC procédures de produits Multi-émetteur.