

. Manual Requirement of FCC / IC

Our product (EG00270) is one of vehicle parts incorporated into the vehicle as original equipment. Therefore, we will not supply the user's manual. However, we will ask the vehicle manufacturer to include following statements in the vehicle user's manual in accordance with FCC and IC requirements.

1. Requirement for User Manual

1.1. FCC Requirement

1.1.1. In accordance with 15.21 of FCC rule, following statement will be included in the user's manual.

FCC WARNING

Changes or modifications not expressly approved by the party responsible for compliance could void the user's authority to operate the equipment.

1.1.2. In accordance with requirement of FCC§15.19(a)(5), following statement will be included in the user's manual.

NOTE

This device complies with part 15 of the FCC Rules. Operation is subject to the following two conditions: (1) This device may not cause harmful interference, and (2) this device must accept any interference received, including interference that may cause undesired operation.

1.2. IC Requirement

1.2.1. In accordance with requirement of RSS-GEN, following statement will be included in the user's manual.

NOTE

Operation is subject to the following two conditions: (1) this device may not cause interference, and (2) this device must accept any interference, including interference that may cause undesired operation of the device.

2. Technical description of the system

2.1 Type number

-Smart Key ECU : EG00270

2.2 Specifications

- Nominal Power supply voltage : 12VDC

Receiver(RF)

-Nominal frequency : 433.92MHz
-Oscillator frequency : 21.948717MHz (Crystal)
-Type of modulation : FSK(F1D)
-Type of receiving system : Super-heterodyne
-Antenna : RF ANT : Internal antenna

Transmitter(LF)

-Nominal frequency : 134.2kHz
-Oscillator frequency : 4.026 MHz (Crystal)
-Type of modulation : OOK(A1D)
-Antenna : LF ANT1: External antenna (inside Cabin)
LF ANT2: External antenna (inside Trunk)
LF ANT3: External antenna (inside Bumper)
LF ANT4: External antenna (Built in Door HDL)
LF ANT5: External antenna (Built in Door HDL)

Transponder

-Nominal frequency : 134.2kHz
-Oscillator frequency : 4.00MHz (Resonator)
-Type of modulation : OOK(A1D)
-Antenna : TP ANT: External antenna (Built in SSB)

3. Outline of the system

A Smart Key system is a comfort feature that allows the user to lock, unlock without using a mechanical key.

Once the user has accessed into the vehicle, with his Smart Key Fob he has the possibility to switch between terminals (OFF-ACC-IGN) and to start the engine.

The user has to carry with him the Smart Key Fob as a wireless authentication is performed when toggle button or Start Stop Button inputs are triggered.

3.1. Smart Key ECU

The SMK manages all functions related to "SMK Start"

The SMK unit reads the inputs (e.g. Start Stop Button), controls the outputs (e.g. exterior and interior antennas), and communicates via the CAN network as well as a single line interface to further devices of the car.

For communication with the SMART FOB, SMK generates a request (challenge) as an encoded and modulated signal (134.2 kHz) at the inductive antenna outputs and receives the SMART key FOB's response via the internal RF ANT and internal receiver.

The LF antenna amplifier/driver generates a sinusoidal carrier signal (134.2 kHz), which is distributed to the different antennas. The signal is 100%-ASK modulated by switching on and off the carrier.

3.2. LF Antennas:

Inductive antennas in and at the vehicle are used to transform the current, driven by the SMK antenna driver, into a magnetic field (134.2 kHz), which is the carrier for the SMK challenge.

One antenna covers the vehicle's interior. One antenna covers the interior of the Trunk.

Two antenna in the Door Handles (Left side and Right side) cover the area around the doors. One antenna in the rear bumper covers the area around the trunk for access to the trunk.. Those antennas are based on ferrite core and have a pair of twisted copper cables from antenna to pin header.

3.3. Transponder Antenna:

Built in the Start Stop Button to communicate with the transponder by a base station and using wireless communication :(134.2kHz)

3.4 Installation in vehicle

The Smart Key ECU is installed inside the vehicle.

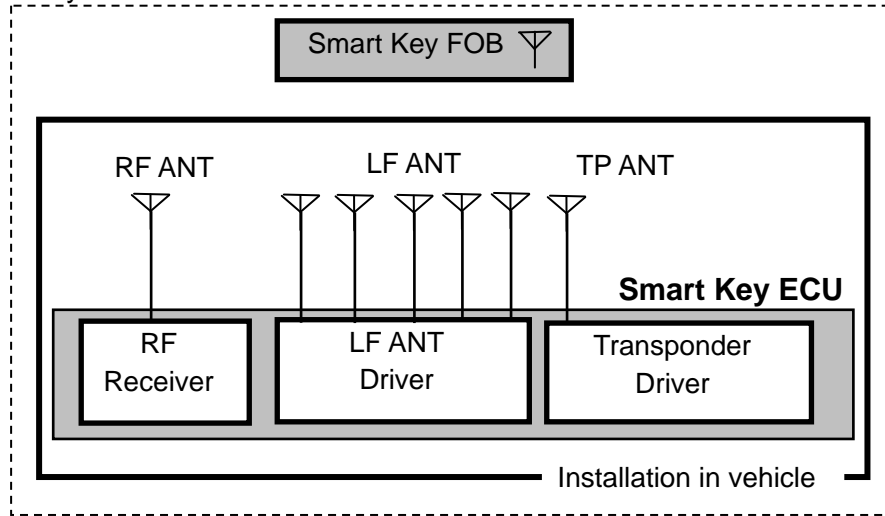

Fig. Outline of the System

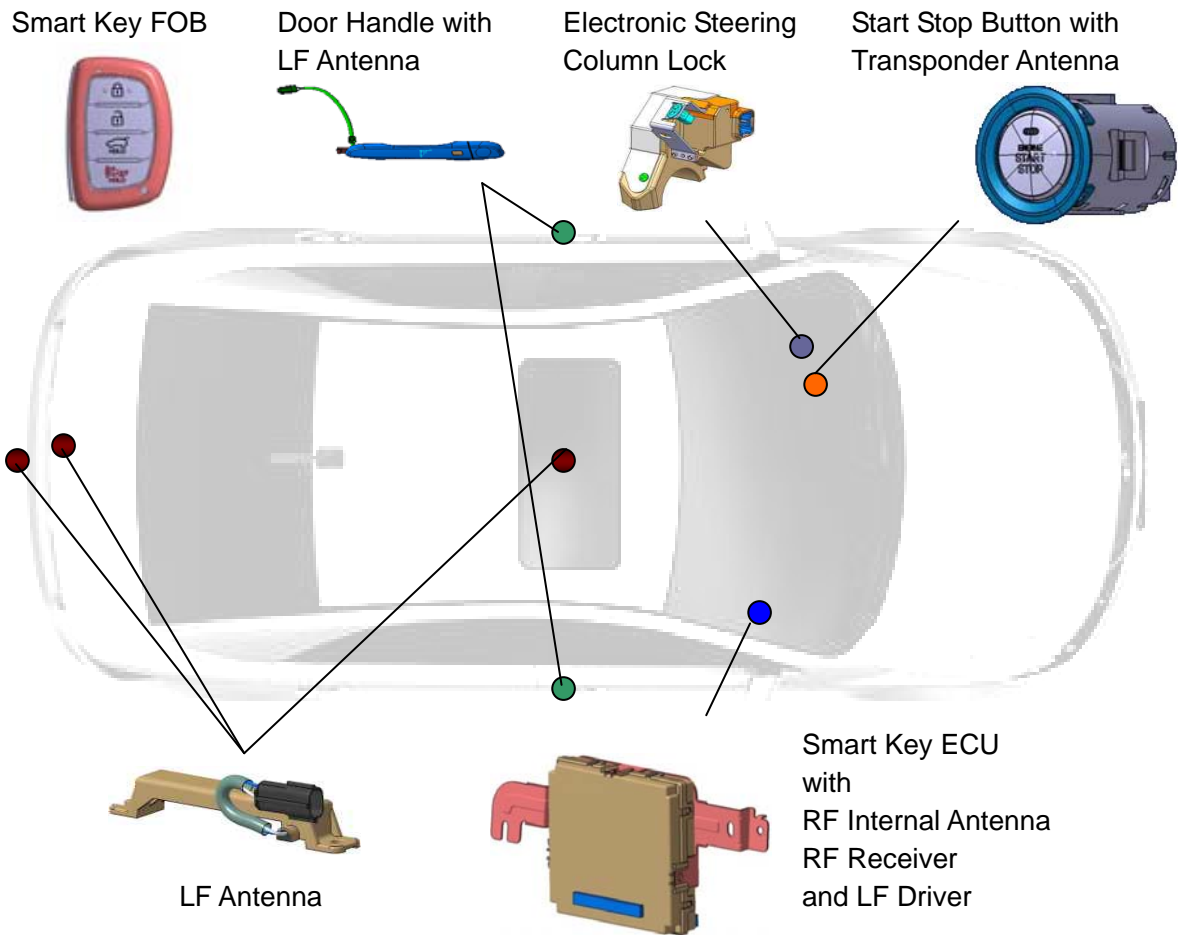

Fig. Installation of the System