



# FCC RF Test Report

**APPLICANT** : Universal Global Scientific Industrial Co., Ltd.  
**EQUIPMENT** : LTE module  
**BRAND NAME** : SEQUANS Communications  
**MODEL NAME** : VZ22Q, VZ22M  
**MARKETING NAME** : EZLinkLTE VZ22Q, EZLinkLTE VZ22M  
**FCC ID** : COFVZ22Q  
**STANDARD** : 47 CFR Part 2, 27  
**CLASSIFICATION** : Licensed Non-Broadcast Station Transmitter (TNB)

The product was received on Dec. 12, 2014 and completely tested on Jan. 14, 2015. We, SPORTON INTERNATIONAL INC., would like to declare that the tested sample has been evaluated in accordance with the test procedures given in ANSI / TIA / EIA-603-C-2004 and the testing has shown the tested sample to be in compliance with the applicable technical standards.

The test results in this report apply exclusively to the tested model / sample. Without written approval of SPORTON INTERNATIONAL INC., the test report shall not be reproduced except in full.

Reviewed by: Joseph Lin / Supervisor

Approved by: Jones Tsai / Manager



## SPORTON INTERNATIONAL INC.

No. 52, Hwa Ya 1<sup>st</sup> Rd., Hwa Ya Technology Park, Kwei-Shan Hsiang, Tao Yuan Hsien, Taiwan, R.O.C.



# TABLE OF CONTENTS

**REVISION HISTORY** ..... 4

**SUMMARY OF TEST RESULT** ..... 5

**1 GENERAL DESCRIPTION** ..... 6

    1.1 Applicant ..... 6

    1.2 Manufacturer ..... 6

    1.3 Product Feature of Equipment Under Test ..... 6

    1.4 Product Specification subjective to this standard ..... 6

    1.5 Modification of EUT ..... 6

    1.6 Emission Designator ..... 7

    1.7 Testing Location ..... 7

    1.8 Applicable Standards ..... 8

**2 TEST CONFIGURATION OF EQUIPMENT UNDER TEST** ..... 9

    2.1 Test Mode ..... 9

    2.2 Connection Diagram of Test System ..... 10

    2.3 Support Unit used in test configuration and system ..... 10

    2.4 Measurement Results Explanation Example ..... 11

**3 CONDUCTED TEST ITEMS** ..... 12

    3.1 Measuring Instruments ..... 12

    3.2 Test Setup ..... 12

    3.3 Test Result of Conducted Test ..... 13

    3.4 Conducted Output Power ..... 13

    3.5 Peak-to-Average Ratio ..... 14

    3.6 Occupied Bandwidth ..... 15

    3.7 Conducted Band Edge ..... 16

    3.8 Conducted Spurious Emission ..... 17

    3.9 Frequency Stability ..... 18

**4 RADIATED TEST ITEMS** ..... 19

    4.1 Measuring Instruments ..... 19

    4.2 Test Setup ..... 19

    4.3 Test Result of Radiated Test ..... 19

    4.4 Radiated Spurious Emission ..... 20

**5 LIST OF MEASURING EQUIPMENT** ..... 21

**6 UNCERTAINTY OF EVALUATION** ..... 22

**APPENDIX A. TEST RESULTS OF CONDUCTED TEST**

**APPENDIX B. TEST RESULTS OF RADIATED TEST**



**APPENDIX C. TEST SETUP PHOTOGRAPHS**



### REVISION HISTORY

REPORT NO.	VERSION	DESCRIPTION	ISSUED DATE
FG4D1209	Rev. 01	Initial issue of report	Jan. 28, 2015



### SUMMARY OF TEST RESULT

Report Section	FCC Rule	Description	Limit	Result	Remark
3.4	§2.1046	Conducted Output Power	Reporting Only	PASS	-
3.5	N/A	Peak-to-Average Ratio	<13 dB	PASS	-
3.6	§2.1049 §27.53(h)(3)	Occupied Bandwidth	Reporting Only	PASS	-
3.7	§2.1051 §27.53(c)(2) §27.53(c)(4) §27.53(f) §27.53(g)	Conducted Band Edge Measurement (Band 4) (Band 13)	< 43+10log <sub>10</sub> (P[Watts])	PASS	-
3.8	§2.1051 §27.53(c)(2) §27.53(f) §27.53(g)	Conducted Spurious Emission (Band 4) (Band 13)	< 43+10log <sub>10</sub> (P[Watts])	PASS	-
3.9	§2.1055 §27.54	Frequency Stability Temperature & Voltage	Within Authorized Band	PASS	-
4.4	§2.1053 §27.53(c)(2) §27.53(f) §27.53(h)	Radiated Spurious Emission (Band 4) (Band 13)	< 43+10log <sub>10</sub> (P[Watts])	PASS	Under limit 7.29 dB at 1560.000 MHz



# 1 General Description

## 1.1 Applicant

Universal Global Scientific Industrial Co., Ltd.  
141, Lane 351, Taiping Road, Tsaotuen, Nantou 54261, Taiwan

## 1.2 Manufacturer

Universal Scientific Industrial (Shanghai)  
No. 1558, Zhang Dong Road, Zhangjiang Hi-Tech Park, Shanghai, P.R. China 201203

## 1.3 Product Feature of Equipment Under Test

Product Feature	
Equipment	LTE module
Brand Name	SEQUANS Communications
Model Name	VZ22Q, VZ22M
FCC ID	COFVZ22Q
EUT supports Radios application	LTE
HW Version	V01
SW Version	17940
EUT Stage	Identical Prototype

## 1.4 Product Specification subjective to this standard

Product Specification subjective to this standard	
Tx Frequency	LTE Band 4 : 1712.5 MHz ~ 1752.5 MHz LTE Band 13 : 779.5 MHz ~ 784.5 MHz
Rx Frequency	LTE Band 4 : 2112.5 MHz ~ 2152.5 MHz LTE Band 13 : 748.5 MHz ~ 753.5 MHz
Bandwidth	LTE Band 4 : 5MHz / 10MHz / 15MHz / 20MHz LTE Band 13 : 5MHz / 10MHz
Maximum Output Power to Antenna	LTE Band 4 : 22.96 dBm LTE Band 13 : 23.44 dBm
Type of Modulation	QPSK / 16QAM / 64QAM (Downlink Only)

## 1.5 Modification of EUT

No modifications are made to the EUT during all test items.



### 1.6 Emission Designator

LTE Band 4	QPSK		16QAM	
BW(MHz)	Occupied Bandwidth (MHz)	Frequency Tolerance (ppm)	Occupied Bandwidth (MHz)	Frequency Tolerance (ppm)
5	4.56	-	4.54	-
10	9.18	0.0072	9.18	-
15	13.53	-	13.53	-
20	18.84	-	18.76	-
LTE Band 13	QPSK		16QAM	
BW(MHz)	Occupied Bandwidth (MHz)	Frequency Tolerance (ppm)	Occupied Bandwidth (MHz)	Frequency Tolerance (ppm)
5	4.54	-	4.54	-
10	9.14	0.0093	9.16	-

### 1.7 Testing Location

Sporton Lab is accredited to ISO 17025 by Taiwan Accreditation Foundation (TAF code : 1190) and the FCC designation No. TW1022 under the FCC 2.948(e) by Mutual Recognition Agreement (MRA) in FCC Test.

<b>Test Site</b>	SPORTON INTERNATIONAL INC.
<b>Test Site Location</b>	No. 52, Hwa Ya 1 <sup>st</sup> Rd., Hwa Ya Technology Park, Kwei-Shan Hsiang, Tao Yuan Hsien, Taiwan, R.O.C. TEL: +886-3-327-3456 FAX: +886-3-328-4978
<b>Test Site No.</b>	<b>Sporton Site No.</b> TH02-HY

<b>Test Site</b>	SPORTON INTERNATIONAL INC.
<b>Test Site Location</b>	No.58, Alley. 75, Lane 564, Wenhua 3 <sup>rd</sup> Rd. Kwei-Shan Hsiang, Taoyuan Hsien, Taiwan (R.O.C.) TEL: +886-3-327-0838
<b>Test Site No.</b>	<b>Sporton Site No.</b> 03CH10-HY



## 1.8 Applicable Standards

According to the specifications of the manufacturer, the EUT must comply with the requirements of the following standards:

- ♦ 47 CFR Part 2, 27
- ♦ ANSI / TIA / EIA-603-C-2004
- ♦ FCC KDB 971168 D01 Power Meas. License Digital Systems v02r02

### **Remark:**

1. All test items were verified and recorded according to the standards and without any deviation during the test.
2. This EUT has also been tested and complied with the requirements of FCC Part 15, Subpart B, recorded in a separate test report.





## 2 Test Configuration of Equipment Under Test

### 2.1 Test Mode

Antenna port conducted and radiated test items listed below are performed according to KDB 971168 D01 Power Meas. License Digital Systems v02r02 with maximum output power.

Test Items	Band	Bandwidth (MHz)						Modulation		RB #			Test Channel		
		1.4	3	5	10	15	20	QPSK	16QAM	1	Half	Full	L	M	H
Max. Output Power	4	-	-	Y	Y	Y	Y	Y	Y	Y	Y	Y	Y	Y	Y
	13	-	-	Y	Y	-	-	Y	Y	Y	Y	Y	Y	Y	Y
Peak-to-Average Ratio	4	-	-				Y	Y	Y	Y		Y	Y	Y	Y
	13	-	-		Y	-	-	Y	Y	Y		Y	Y	Y	Y
26dB and 99% Bandwidth	4	-	-	Y	Y	Y	Y	Y	Y			Y	Y	Y	Y
	13	-	-	Y	Y	-	-	Y	Y			Y	Y	Y	Y
Conducted Band Edge	4	-	-	Y	Y	Y	Y	Y	Y	Y		Y	Y		Y
	13	-	-	Y	Y	-	-	Y	Y	Y		Y	Y		Y
Conducted Spurious Emission	4	-	-	Y	Y	Y	Y	Y	Y	Y			Y	Y	Y
	13	-	-	Y	Y	-	-	Y	Y	Y			Y	Y	Y
Frequency Stability	4	-	-		Y			Y				Y		Y	
	13	-	-		Y	-	-	Y				Y		Y	
Radiated Spurious Emission	4	-	-	Y	Y	Y	Y	Y		Y			Y	Y	Y
	13	-	-	Y	Y	-	-	Y		Y			Y	Y	Y
Note	<ol style="list-style-type: none"> <li>The mark "Y" means that this configuration is chosen for testing</li> <li>The mark "-" means that this bandwidth is not supported.</li> <li>The device is investigated from 30MHz to 10 times of fundamental signal for radiated spurious emission test under different RB size/offset and modulations in exploratory test. Subsequently, only the worst case emissions are reported.</li> </ol>														

## 2.2 Connection Diagram of Test System

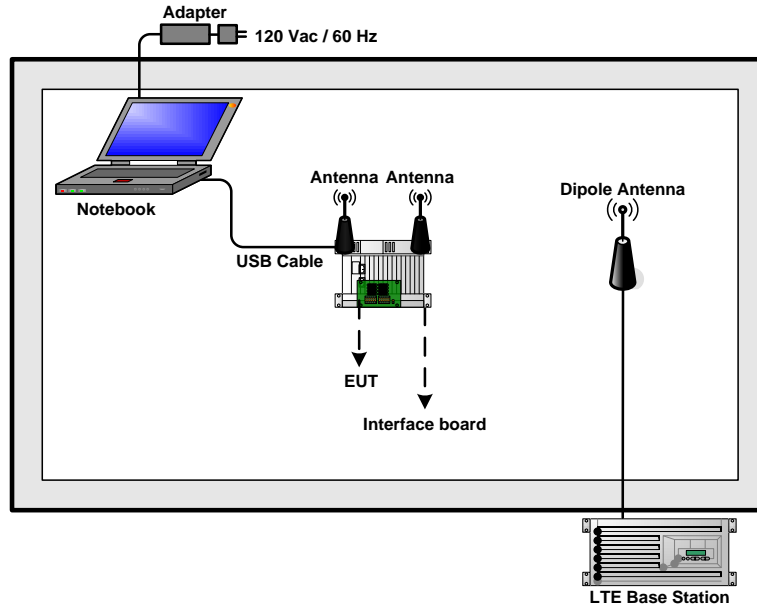

## 2.3 Support Unit used in test configuration and system

Item	Equipment	Trade Name	Model No.	FCC ID	Data Cable	Power Cord
1.	LTE Base Station	Anritsu	MT8820C	N/A	N/A	Unshielded, 1.8 m
2.	Notebook	DELL	P20G	FCC DoC/ Contains FCC ID:QDS-BRCM1051	N/A	AC I/P: Unshielded, 1.2 m DC O/P: Shielded, 1.8 m
3.	Interface board	Sequans Communications	HWPT003	N/A	N/A	N/A
4.	Dipole Antenna	N/A	N/A	N/A	N/A	N/A
5.	USB Cable	N/A	N/A	N/A	Unshielded, 1.0 m	N/A



## **2.4 Measurement Results Explanation Example**

**For all conducted test items:**

The offset level is set in the spectrum analyzer to compensate the RF cable loss and attenuator factor between EUT conducted output port and spectrum analyzer. With the offset compensation, the spectrum analyzer reading level is exactly the EUT RF output level.

The spectrum analyzer offset is derived from RF cable loss and attenuator factor.

*Offset = RF cable loss + attenuator factor.*

Following shows an offset computation example with cable loss 4.2 dB and 10dB attenuator.

Example :

$$\begin{aligned} \text{Offset(dB)} &= \text{RF cable loss(dB)} + \text{attenuator factor(dB)}. \\ &= 4.2 + 10 = 14.2 \text{ (dB)} \end{aligned}$$

### 3 Conducted Test Items

#### 3.1 Measuring Instruments

See list of measuring instruments of this test report.

#### 3.2 Test Setup

##### 3.2.1 Conducted Output Power

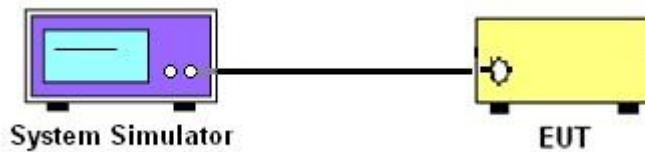

##### 3.2.2 Peak-to-Average Ratio, Occupied Bandwidth ,Conducted Band-Edge and Conducted Spurious Emission



##### 3.2.3 Frequency Stability

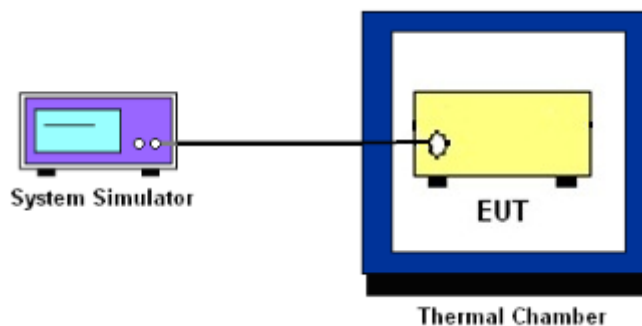



### **3.3 Test Result of Conducted Test**

Please refer to Appendix A.

### **3.4 Conducted Output Power**

#### **3.4.1 Description of the Conducted Output Power Measurement**

A system simulator was used to establish communication with the EUT. Its parameters were set to force the EUT transmitting at maximum output power. The measured power in the radio frequency on the transmitter output terminals shall be reported.

#### **3.4.2 Test Procedures**

1. The transmitter output port was connected to the system simulator.
2. Set EUT at maximum power through the system simulator.
3. Select lowest, middle, and highest channels for each band and different modulation.
4. Measure and record the power level from the system simulator.



## **3.5 Peak-to-Average Ratio**

### **3.5.1 Description of the PAR Measurement**

Power Complementary Cumulative Distribution Function (CCDF) curves provide a means for characterizing the power peaks of a digitally modulated signal on a statistical basis. A CCDF curve depicts the probability of the peak signal amplitude exceeding the average power level. Most contemporary measurement instrumentation include the capability to produce CCDF curves for an input signal provided that the instrument's resolution bandwidth can be set wide enough to accommodate the entire input signal bandwidth. In measuring transmissions in this band using an average power technique, the peak-to-average ratio (PAR) of the transmission may not exceed 13 dB.

### **3.5.2 Test Procedures**

1. The testing follows FCC KDB 971168 v02r02 Section 5.7.1.
2. The EUT was connected to spectrum and system simulator via a power divider.
3. Set the CCDF (Complementary Cumulative Distribution Function) option in spectrum analyzer.
4. The highest RF powers were measured and recorded the maximum PAPR level associated with a probability of 0.1 %.
5. Record the deviation as Peak to Average Ratio.



## **3.6 Occupied Bandwidth**

### **3.6.1 Description of Occupied Bandwidth Measurement**

The occupied bandwidth is the width of a frequency band such that, below the lower and above the upper frequency limits, the mean powers emitted are each equal to a specified percentage 0.5% of the total mean transmitted power.

The 26 dB emission bandwidth is defined as the frequency range between two points, one above and one below the carrier frequency, at which the spectral density of the emission is attenuated 26 dB below the maximum in-band spectral density of the modulated signal. Spectral density (power per unit bandwidth) is to be measured with a detector of resolution bandwidth equal to approximately 1.0% of the emission bandwidth.

### **3.6.2 Test Procedures**

1. The testing follows FCC KDB 971168 v02r02 Section 4.2.
2. The EUT was connected to spectrum analyzer and system simulator via a power divider.



### 3.7 Conducted Band Edge

#### 3.7.1 Description of Conducted Band Edge Measurement

27.53 (c) for Band 13

For operations in the 776-788 MHz band, the FCC limit is  $43 + 10\log_{10}(P[\text{Watts}])$  dB below the transmitter power P(Watts) in a 100 kHz bandwidth. However, in the 100 kHz bands immediately outside and adjacent to the frequency block, a resolution bandwidth of at least 30 kHz may be employed. In addition, the power of any unwanted emissions in any 6.25 kHz bandwidth for all frequencies between 763-775 MHz and 793-806 MHz shall be attenuated below the transmitter power, P (dBW), by at least  $65 + 10 \log_{10} p(\text{watts})$ , dB, for mobile and portable equipment.

27.53 (h) for Band 4

For operations in the 1710 – 1755 MHz band, the FCC limit is  $43 + 10\log_{10}(P[\text{Watts}])$  dB below the transmitter power P(Watts) in a 1 MHz bandwidth. However, in the 1MHz bands immediately outside and adjacent to the licensee's frequency block, a resolution bandwidth of at least one percent of the emission bandwidth of the fundamental emission of the transmitter may be employed.

#### 3.7.2 Test Procedures

1. The testing follows FCC KDB 971168 v02r02 Section 6.0.
2. The EUT was connected to spectrum analyzer and system simulator via a power divider.
3. The band edges of low and high channels for the highest RF powers were measured. Set RBW  $\geq 1\%$  EBW in the 1MHz band immediately outside and adjacent to the band edge.
4. Set spectrum analyzer with RMS detector.
5. The RF fundamental frequency should be excluded against the limit line in the operating frequency band.
6. The limit line is derived from  $43 + 10\log(P)\text{dB}$  below the transmitter power P(Watts)  
 $= P(\text{W}) - [43 + 10\log(P)] (\text{dB})$   
 $= [30 + 10\log(P)] (\text{dBm}) - [43 + 10\log(P)] (\text{dB})$   
 $= -13\text{dBm}.$





## 3.8 Conducted Spurious Emission

### 3.8.1 Description of Conducted Spurious Emission Measurement

The power of any emission outside of the authorized operating frequency ranges must be lower than the transmitter power (P) by a factor of at least  $43 + 10 \log (P)$  dB.

It is measured by means of a calibrated spectrum analyzer and scanned from 30 MHz up to a frequency including its 10<sup>th</sup> harmonic.

### 3.8.2 Test Procedures

1. The testing follows FCC KDB 971168 v02r02 Section 6.0.
2. The EUT was connected to spectrum analyzer and system simulator via a power divider.
3. The RF output of EUT was connected to the spectrum analyzer by RF cable and attenuator. The path loss was compensated to the results for each measurement.
4. The middle channel for the highest RF power within the transmitting frequency was measured.
5. The conducted spurious emission for the whole frequency range was taken.
6. Make the measurement with the spectrum analyzer's RBW = 1MHz, VBW = 3MHz, taking the record of maximum spurious emission.
7. The RF fundamental frequency should be excluded against the limit line in the operating frequency band.
8. The limit line is derived from  $43 + 10\log(P)$ dB below the transmitter power P(Watts)  
= P(W)- [43 + 10log(P)] (dB)  
= [30 + 10log(P)] (dBm) - [43 + 10log(P)] (dB)  
= -13dBm.



## 3.9 Frequency Stability

### 3.9.1 Description of Frequency Stability Measurement

The frequency stability shall be measured by variation of ambient temperature and variation of primary supply voltage to ensure that the fundamental emission stays within the authorized frequency block. The frequency stability of the transmitter shall be maintained within  $\pm 0.00025\%$  ( $\pm 2.5\text{ppm}$ ) of the center frequency.

### 3.9.2 Test Procedures for Temperature Variation

1. The EUT was set up in the thermal chamber and connected with the system simulator.
2. With power OFF, the temperature was decreased to  $-30^{\circ}\text{C}$  and the EUT was stabilized before testing. Power was applied and the maximum change in frequency was recorded within one minute.
3. With power OFF, the temperature was raised in  $10^{\circ}\text{C}$  step up to  $50^{\circ}\text{C}$ . The EUT was stabilized at each step for at least half an hour. Power was applied and the maximum frequency change was recorded within one minute.

### 3.9.3 Test Procedures for Voltage Variation

1. The testing follows FCC KDB 971168 v02r02 Section 9.0.
2. The EUT was placed in a temperature chamber at  $25\pm 5^{\circ}\text{C}$  and connected with the system simulator.
3. The power supply voltage to the EUT was varied from 85% to 115% of the nominal value measured at the input to the EUT.
4. The variation in frequency was measured for the worst case.

## 4 Radiated Test Items

### 4.1 Measuring Instruments

See list of measuring instruments of this test report.

### 4.2 Test Setup

#### 4.2.1 For radiated test from 30MHz to 1GHz

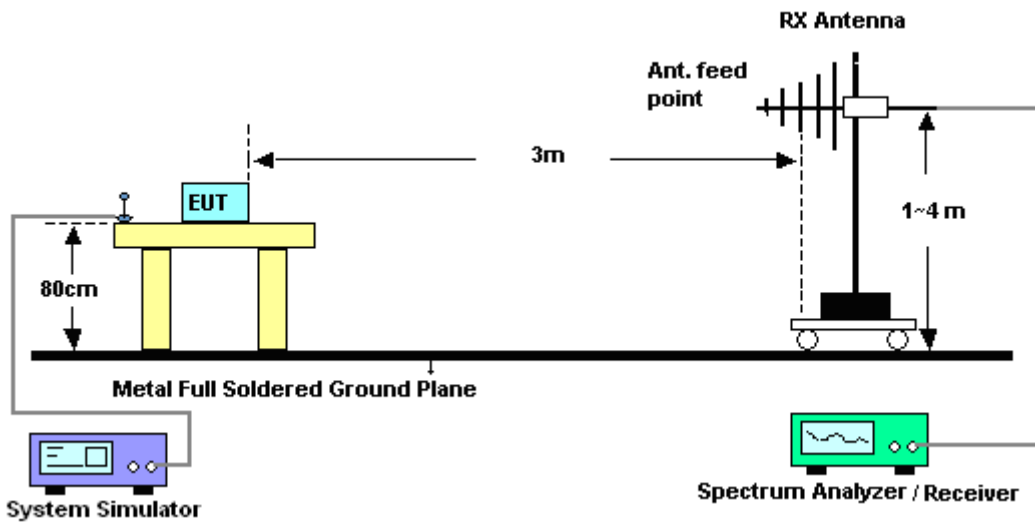

#### 4.2.2 For radiated test above 1GHz

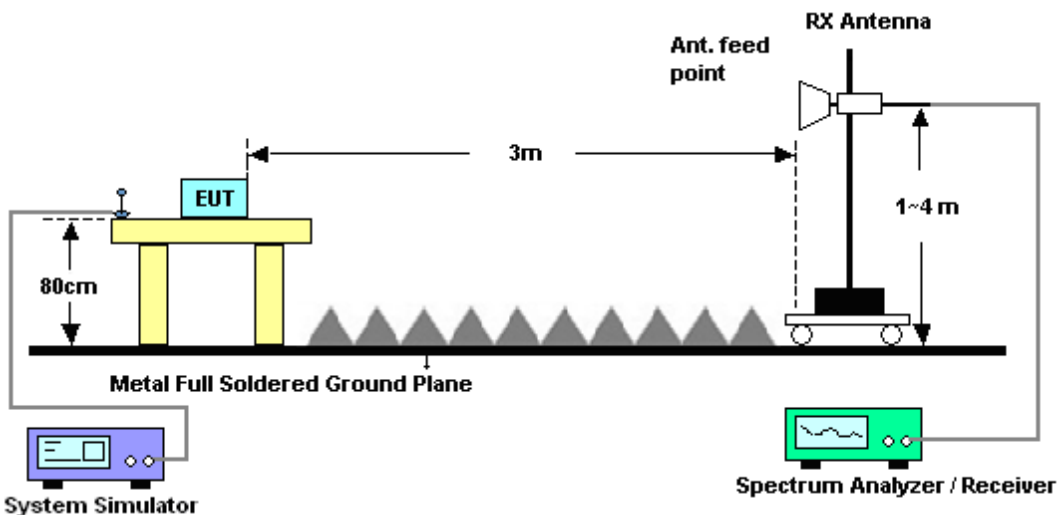

### 4.3 Test Result of Radiated Test

Please refer to Appendix B.



## 4.4 Radiated Spurious Emission

### 4.4.1 Description of Radiated Spurious Emission

The radiated spurious emission was measured by substitution method according to ANSI / TIA / EIA-603-C-2004. The power of any emission outside of the authorized operating frequency ranges must be attenuated below the transmitter power (P) by a factor of at least  $43 + 10 \log (P)$  dB.

The spectrum is scanned from 30 MHz up to a frequency including its 10th harmonic.

### 4.4.2 Test Procedures

1. The testing follows FCC KDB 971168 v02r02 Section 5.8 and ANSI / TIA-603-C-2004 Section 2.2.12.
2. The EUT was placed on a rotatable wooden table with 0.8 meter above ground.
3. The EUT was set 3 meters from the receiving antenna, which was mounted on the antenna tower.
4. The table was rotated 360 degrees to determine the position of the highest spurious emission.
5. The height of the receiving antenna is varied between one meter and four meters to search the maximum spurious emission for both horizontal and vertical polarizations.
6. Make the measurement with the spectrum analyzer's RBW = 1MHz, VBW = 3MHz, taking the record of maximum spurious emission.
7. A horn antenna was substituted in place of the EUT and was driven by a signal generator.
8. Tune the output power of signal generator to the same emission level with EUT maximum spurious emission.
9. Taking the record of output power at antenna port.
10. Repeat step 7 to step 8 for another polarization.
11. The RF fundamental frequency should be excluded against the limit line in the operating frequency band.

The limit line is derived from  $43 + 10\log(P)$ dB below the transmitter power P(Watts)  
 $= P(W) - [43 + 10\log(P)]$  (dB)  
 $= [30 + 10\log(P)]$  (dBm) -  $[43 + 10\log(P)]$  (dB)  
 $= -13$ dBm.

12. EIRP (dBm) = S.G. Power – Tx Cable Loss + Tx Antenna Gain
13. ERP (dBm) = EIRP - 2.15



## 5 List of Measuring Equipment

Instrument	Manufacturer	Model No.	Serial No.	Characteristics	Calibration Date	Test Date	Due Date	Remark
LTE Base Station	Anritsu	MT8820C	620143282 1	30MHz~2.7GHz SISO (FDD Band 1~26)	Oct. 27, 2014	Jan. 07, 2015 ~ Jan. 12, 2015	Oct. 26, 2015	Conducted (TH02-HY)
Spectrum Analyzer	Rohde & Schwarz	FSP40	100055	9kHz~40GHz	Jun. 09, 2014	Jan. 07, 2015 ~ Jan. 12, 2015	Jun. 08, 2015	Conducted (TH02-HY)
Thermal Chamber	Ten Billion	TTH-D3SP	TBN-9307 01	N/A	Jul. 17, 2014	Jan. 07, 2015 ~ Jan. 12, 2015	Jul. 16, 2015	Conducted (TH02-HY)
Spectrum Analyzer	Keysight	N9010A	MY542004 85	10Hz ~ 44GHZ	Oct. 14, 2014	Jan. 14, 2015	Oct. 13, 2015	Radiation (03CH10-HY)
Bilog Antenna	TESEQ	CBL 6111D	35413	30MHz~1GHz	Oct. 24, 2014	Jan. 14, 2015	Oct. 23, 2015	Radiation (03CH10-HY)
Double Ridged Guide Horn Antenna	SCHWARZBECK	BBHA 9120 D	9120D-132 5	1GHz ~ 18GHz	Oct. 03, 2014	Jan. 14, 2015	Oct. 02, 2015	Radiation (03CH10-HY)
Horn Antenna	SCHWARZBECK	BBHA 9170	BBHA9170 584	18GHz- 40GHz	Nov. 03, 2014	Jan. 14, 2015	Nov. 02, 2015	Radiation (03CH10-HY)
Amplifier	SONOMA	310N	187311	0.1MHz~1000M Hz	Nov. 24, 2014	Jan. 14, 2015	Nov. 23, 2015	Radiation (03CH10-HY)
Preamplifier	Keysight	83017A	MY532700 78	1GHz~26.5GHz	Nov. 20, 2014	Jan. 14, 2015	Nov. 19, 2015	Radiation (03CH10-HY)
Turn Table	EMEC	TT 2200	N/A	0-360 degree	N/A	Jan. 14, 2015	N/A	Radiation (03CH10-HY)
Antenna Mast	EMEC	AM-BS-4500- B	N/A	1~4m	N/A	Jan. 14, 2015	N/A	Radiation (03CH10-HY)



## 6 Uncertainty of Evaluation

### Uncertainty of Radiated Emission Measurement (30 MHz ~ 1000 MHz)

Measuring Uncertainty for a Level of Confidence of 95% ( $U = 2Uc(y)$ )	2.54
---	------

### Uncertainty of Radiated Emission Measurement (1 GHz ~ 40 GHz)

Measuring Uncertainty for a Level of Confidence of 95% ( $U = 2Uc(y)$ )	5.5
---	-----



# Appendix A. Test Results of Conducted Test

## Conducted Output Power(Average power)

LTE Band 4 Maximum Average Power [dBm]						
BW [MHz]	RB Size	RB Offset	Mod	Lowest	Middle	Highest
5	1	0	QPSK	21.09	22.14	21.96
5	1	12		22.40	22.86	22.94
5	1	24		21.77	21.96	22.13
5	12	0		21.37	22.23	22.22
5	12	6		21.59	22.32	22.35
5	12	11		21.74	22.24	22.38
5	25	0		21.57	22.20	22.30
5	1	0	16-QAM	21.23	22.07	22.04
5	1	12		21.79	22.33	22.31
5	1	24		21.88	21.95	22.16
5	12	0		20.46	21.37	21.36
5	12	6		20.74	21.45	21.48
5	12	11		20.89	21.38	21.51
5	25	0		20.72	21.36	21.45
10	1	0	QPSK	20.79	22.03	21.47
10	1	24		22.86	22.96	22.88
10	1	49		21.81	21.43	21.79
10	25	0		21.55	22.20	21.95
10	25	12		22.13	22.22	22.17
10	25	24		22.19	21.95	22.13
10	50	0		21.86	22.05	22.04
10	1	0	16-QAM	20.97	22.05	21.62
10	1	24		22.22	22.33	22.24
10	1	49		21.92	21.58	21.83
10	25	0		20.65	21.32	21.05
10	25	12		21.19	21.33	21.27
10	25	24		21.26	21.07	21.23
10	50	0		20.94	21.16	21.10



LTE Band 4 Maximum Average Power [dBm]						
BW [MHz]	RB Size	RB Offset	Mod	Lowest	Middle	Highest
15	1	0	QPSK	20.43	21.73	20.91
15	1	37		22.90	22.91	22.80
15	1	74		21.66	20.80	21.33
15	36	0		21.70	22.11	21.55
15	36	18		22.35	22.19	21.96
15	36	37		22.28	21.75	21.83
15	75	0		22.00	21.94	21.70
15	1	0	16-QAM	20.53	21.73	21.07
15	1	37		22.32	22.24	22.13
15	1	74		21.58	20.90	21.34
15	36	0		20.66	21.17	20.66
15	36	18		21.33	21.22	21.04
15	36	37		21.28	20.76	20.92
15	75	0		20.97	20.94	20.75
20	1	0	QPSK	21.83	22.96	22.10
20	1	49		22.96	22.83	22.54
20	1	99		22.59	22.26	22.43
20	50	0		22.39	22.47	21.93
20	50	24		22.63	22.14	21.77
20	50	49		22.67	21.96	22.03
20	100	0		22.57	22.30	21.95
20	1	0	16-QAM	21.93	22.63	22.09
20	1	49		22.51	21.95	21.78
20	1	99		22.65	21.91	22.38
20	50	0		21.03	21.50	20.80
20	50	24		21.43	21.13	20.84
20	50	49		21.52	20.96	21.00
20	100	0		21.37	21.31	20.94





LTE Band 13 Maximum Average Power [dBm]						
BW [MHz]	RB Size	RB Offset	Mod	Lowest	Middle	Highest
5	1	0	QPSK	22.86	22.56	21.90
5	1	12		23.15	23.44	22.50
5	1	24		22.65	22.33	20.93
5	12	0		22.70	22.40	21.55
5	12	6		22.55	22.38	21.48
5	12	11		22.40	22.44	21.21
5	25	0		22.58	22.49	21.32
5	1	0	16-QAM	22.84	22.65	21.73
5	1	12		22.57	22.73	21.69
5	1	24		22.62	22.44	21.19
5	12	0		21.88	21.45	20.62
5	12	6		21.56	21.46	20.50
5	12	11		21.46	21.44	20.39
5	25	0		21.57	21.46	20.41
10	1	0	QPSK		22.22	
10	1	24			23.17	
10	1	49			21.27	
10	25	0			22.52	
10	25	12			22.48	
10	25	24			22.27	
10	50	0			22.36	
10	1	0	16-QAM		22.33	
10	1	24			22.61	
10	1	49			21.38	
10	25	0			21.44	
10	25	12			21.41	
10	25	24			21.22	
10	50	0			21.25	



**Peak-to-Average Ratio**

Mode	LTE Band 4 / 20MHz				
Mod.	QPSK		16QAM		Limit: 13dB
RB Size	1RB	Full RB	1RB	Full RB	Result
Lowest CH	4.26	4.84	4.55	5.58	PASS
Middle CH	3.56	4.81	3.37	5.48	
Highest CH	3.85	4.94	3.72	5.58	

Mode	LTE Band 13 / 10MHz				
Mod.	QPSK		16QAM		Limit: 13dB
RB Size	1RB	Full RB	1RB	Full RB	Result
Lowest CH	-	-	-	-	PASS
Middle CH	4.97	5.32	4.90	6.12	
Highest CH	-	-	-	-	



LTE Band 4 / 20MHz / QPSK

Lowest Channel / 1RB

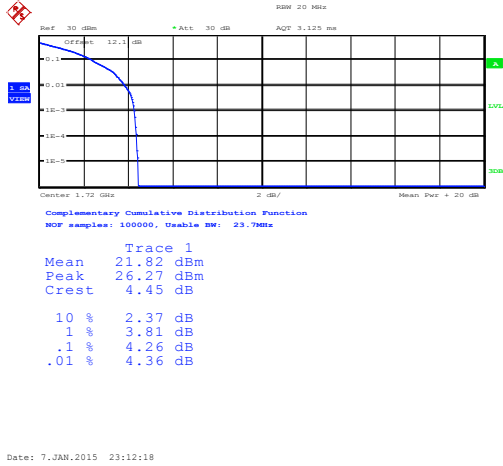

Lowest Channel / Full RB

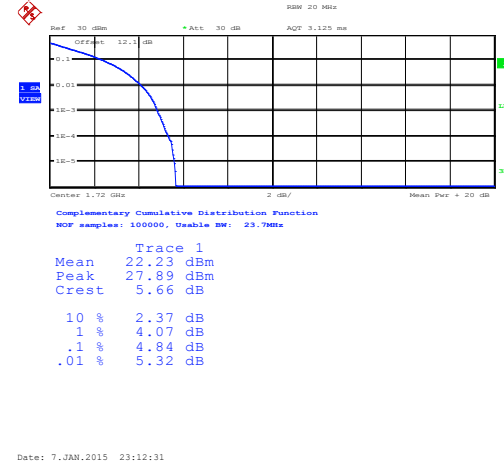

Middle Channel / 1RB

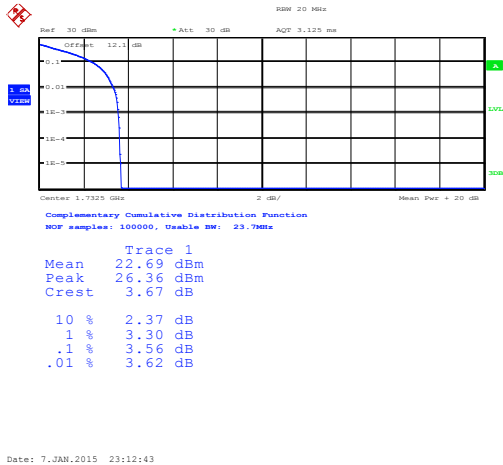

Middle Channel / Full RB

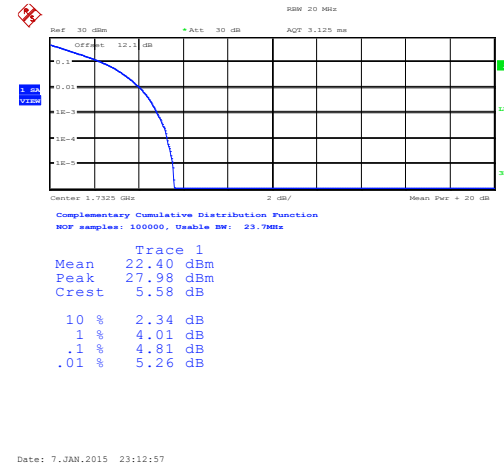

Highest Channel / 1RB

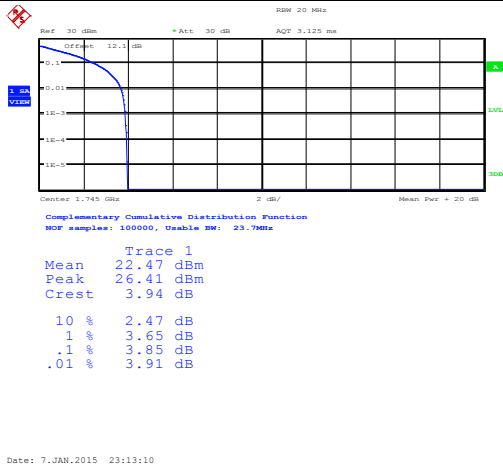

Highest Channel / Full RB

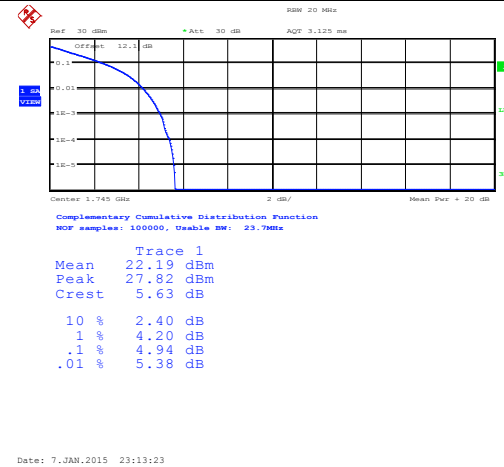



LTE Band 4 / 20MHz / 16QAM

Lowest Channel / 1RB

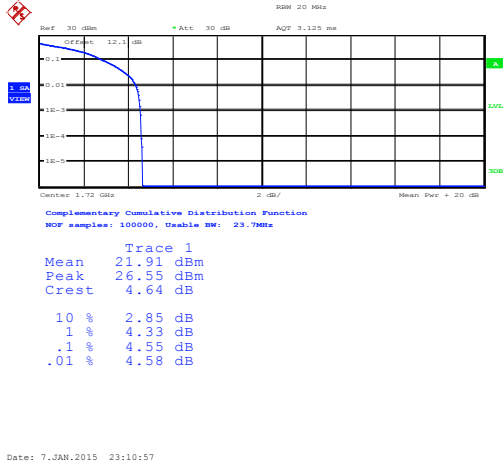

Lowest Channel / Full RB

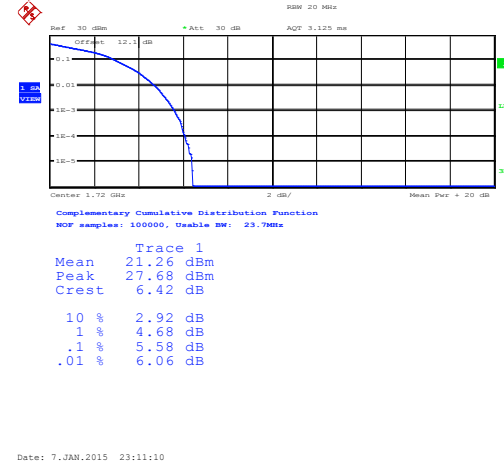

Middle Channel / 1RB

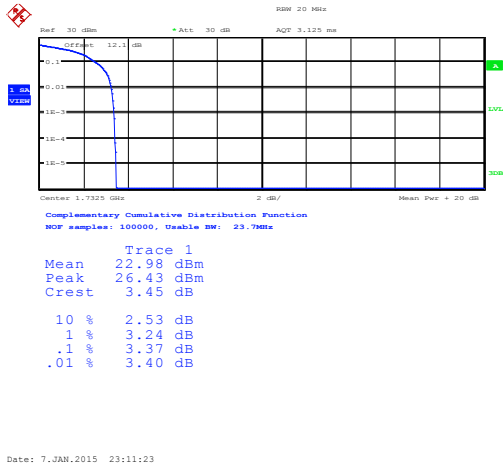

Middle Channel / Full RB

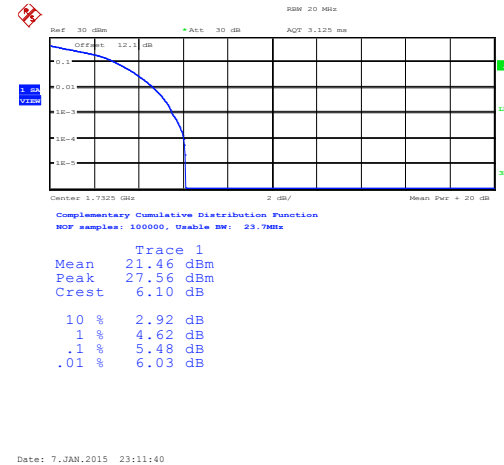

Highest Channel / 1RB

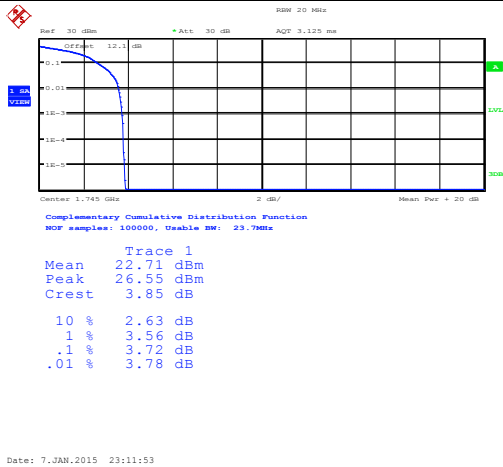

Highest Channel / Full RB

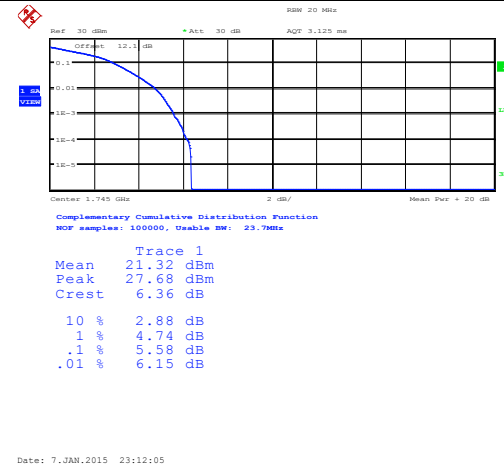



LTE Band 13 / 10MHz / QPSK

Middle Channel / 1RB

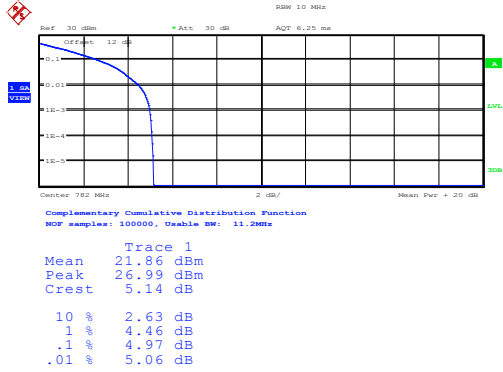

Date: 10.JAN.2015 00:54:21

Middle Channel / Full RB

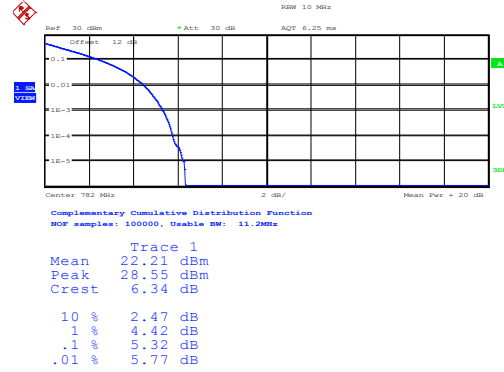

Date: 10.JAN.2015 00:54:34

LTE Band 13 / 10MHz / 16QAM

Middle Channel / 1RB

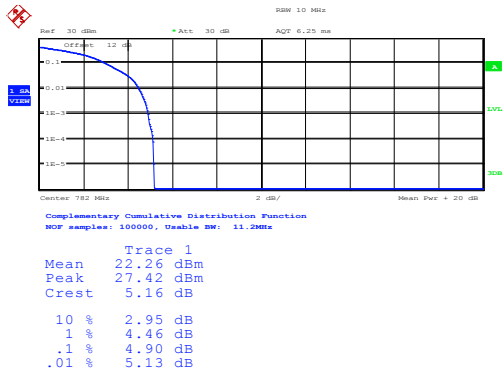

Date: 10.JAN.2015 00:53:53

Middle Channel / Full RB

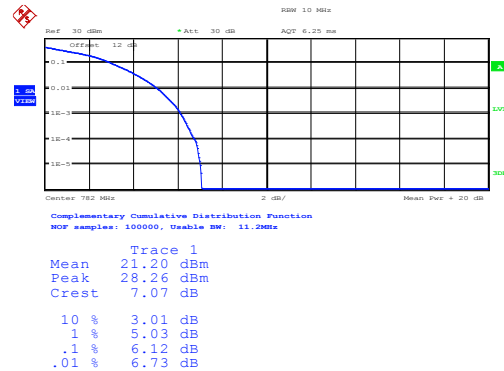

Date: 10.JAN.2015 00:54:07



**26dB Bandwidth**

Mode	LTE Band 4 : 26dB BW(MHz)											
	1.4MHz		3MHz		5MHz		10MHz		15MHz		20MHz	
Mod.	QPSK	16QAM	QPSK	16QAM	QPSK	16QAM	QPSK	16QAM	QPSK	16QAM	QPSK	16QAM
Lowest CH	-	-	-	-	5.39	5.32	11.00	11.38	15.84	15.78	21.92	21.76
Middle CH	-	-	-	-	5.50	5.55	11.22	11.28	15.75	15.60	22.00	21.92
Highest CH	-	-	-	-	5.44	5.56	11.12	11.20	16.08	15.60	21.88	21.84

Mode	LTE Band 13 : 26dB BW(MHz)											
	1.4MHz		3MHz		5MHz		10MHz		15MHz		20MHz	
Mod.	QPSK	16QAM	QPSK	16QAM	QPSK	16QAM	QPSK	16QAM	QPSK	16QAM	QPSK	16QAM
Lowest CH	-	-	-	-	5.67	5.66	-	-	-	-	-	-
Middle CH	-	-	-	-	5.41	5.45	10.90	11.12	-	-	-	-
Highest CH	-	-	-	-	5.39	5.47	-	-	-	-	-	-



LTE Band 4

Lowest Channel / 5MHz / QPSK

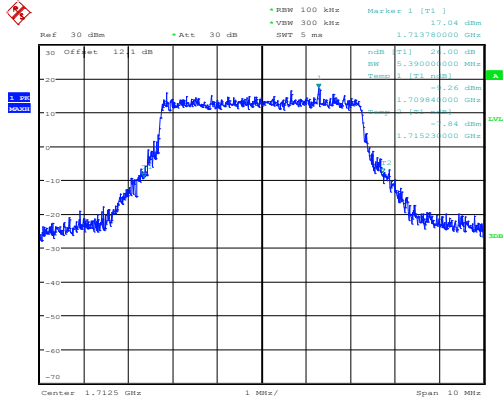

Date: 7.JAN.2015 21:52:36

Lowest Channel / 5MHz / 16QAM

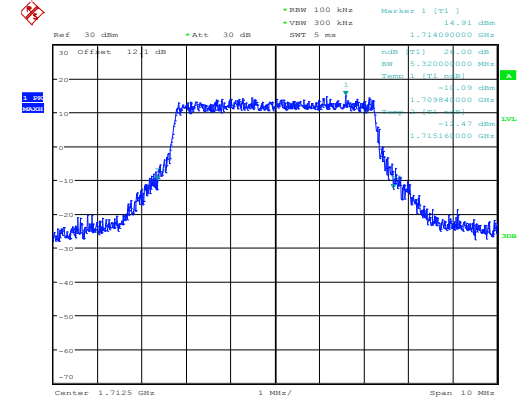

Date: 7.JAN.2015 21:52:49

Middle Channel / 5MHz / QPSK

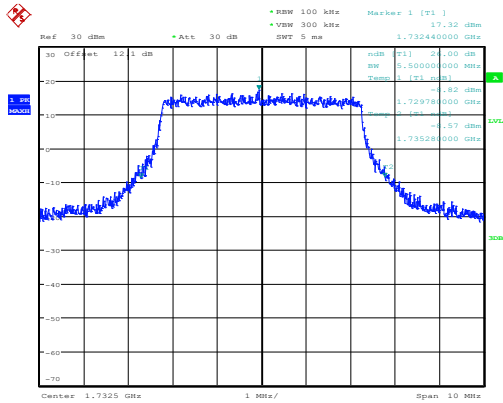

Date: 7.JAN.2015 22:00:29

Middle Channel / 5MHz / 16QAM

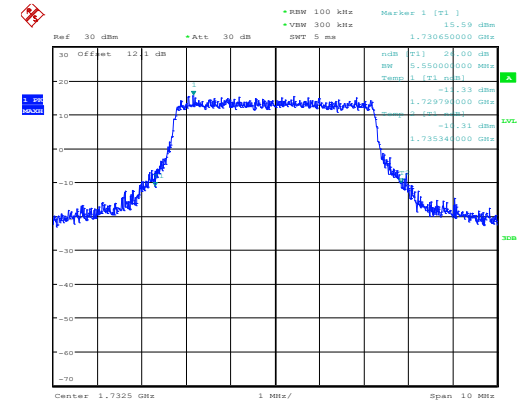

Date: 7.JAN.2015 22:00:41

Highest Channel / 5MHz / QPSK

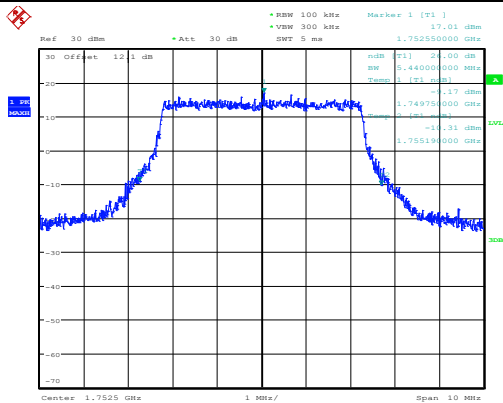

Date: 7.JAN.2015 22:03:37

Highest Channel / 5MHz / 16QAM

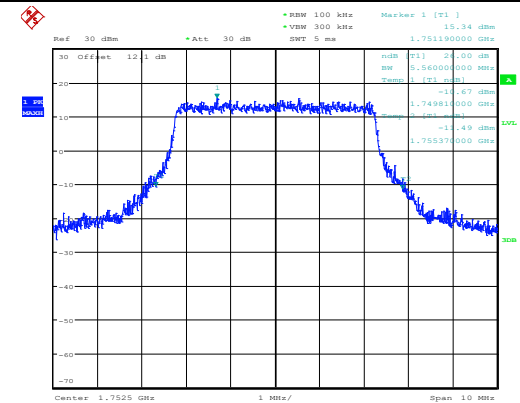

Date: 7.JAN.2015 22:03:50



LTE Band 4

Lowest Channel / 10MHz / QPSK

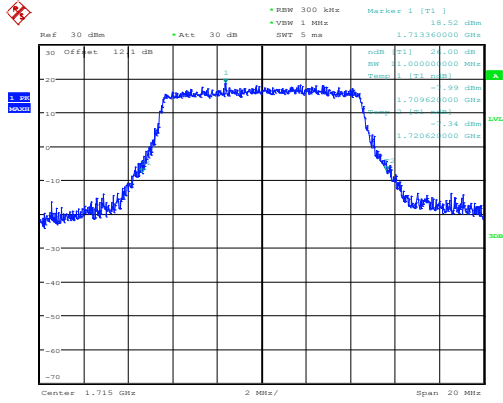

Date: 7.JAN.2015 22:13:09

Lowest Channel / 10MHz / 16QAM

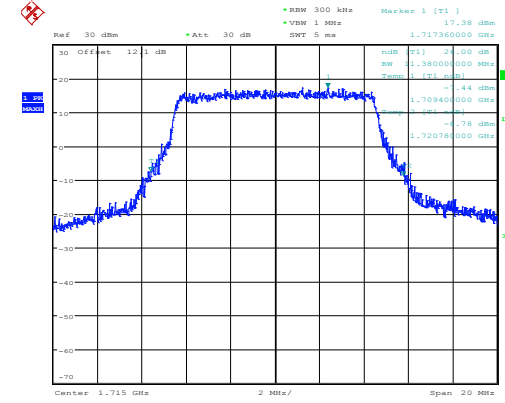

Date: 7.JAN.2015 22:13:21

Middle Channel / 10MHz / QPSK

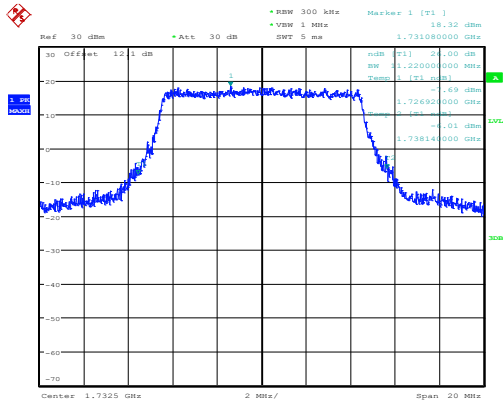

Date: 7.JAN.2015 22:20:54

Middle Channel / 10MHz / 16QAM

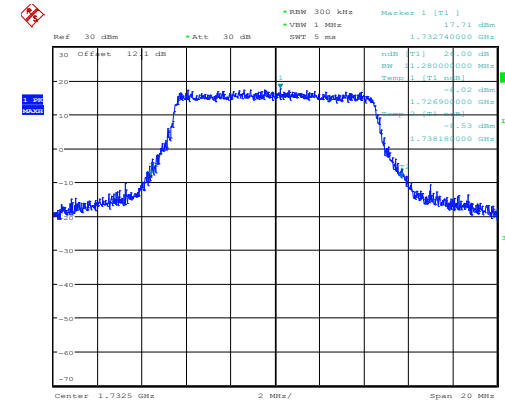

Date: 7.JAN.2015 22:21:07

Highest Channel / 10MHz / QPSK

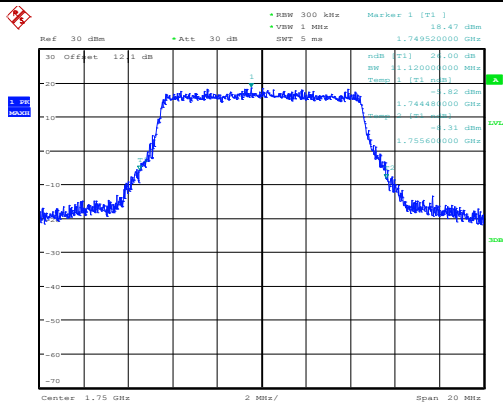

Date: 7.JAN.2015 22:23:59

Highest Channel / 10MHz / 16QAM

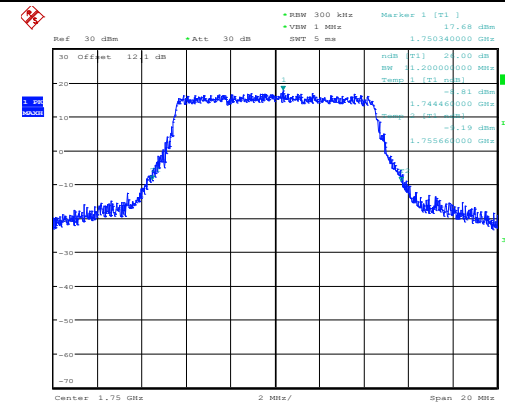

Date: 7.JAN.2015 22:24:11





LTE Band 4

Lowest Channel / 15MHz / QPSK

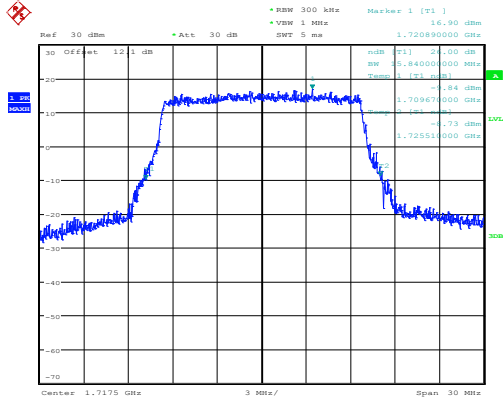

Date: 7.JAN.2015 22:32:10

Lowest Channel / 15MHz / 16QAM

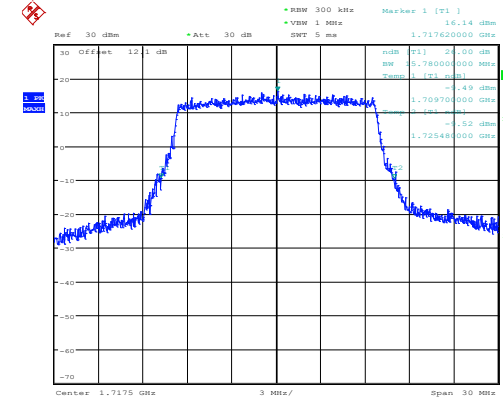

Date: 7.JAN.2015 22:32:23

Middle Channel / 15MHz / QPSK

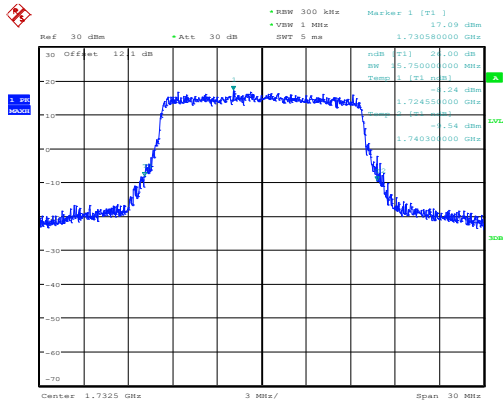

Date: 7.JAN.2015 22:40:01

Middle Channel / 15MHz / 16QAM

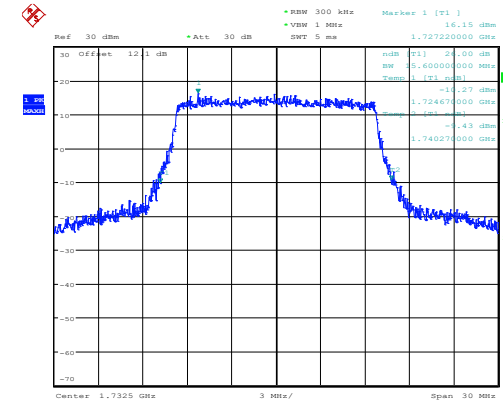

Date: 7.JAN.2015 22:40:13

Highest Channel / 15MHz / QPSK

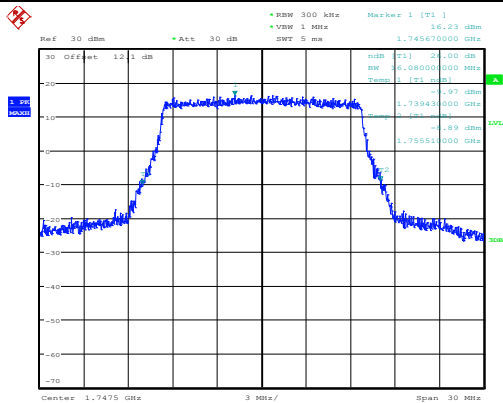

Date: 7.JAN.2015 22:43:09

Highest Channel / 15MHz / 16QAM

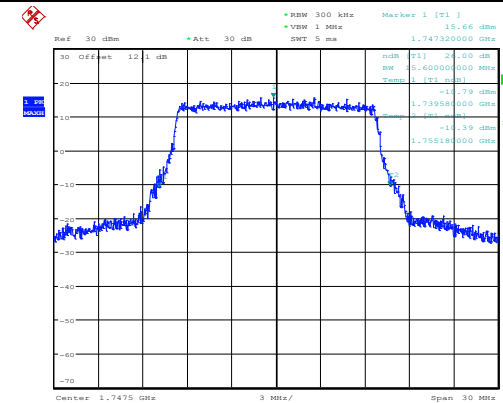

Date: 7.JAN.2015 22:43:22



LTE Band 4

Lowest Channel / 20MHz / QPSK

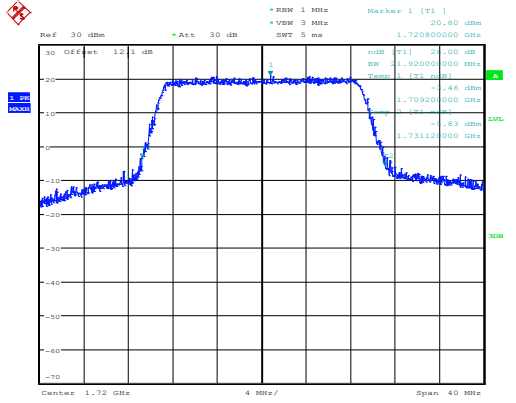

Date: 7.JAN.2015 22:51:29

Lowest Channel / 20MHz / 16QAM

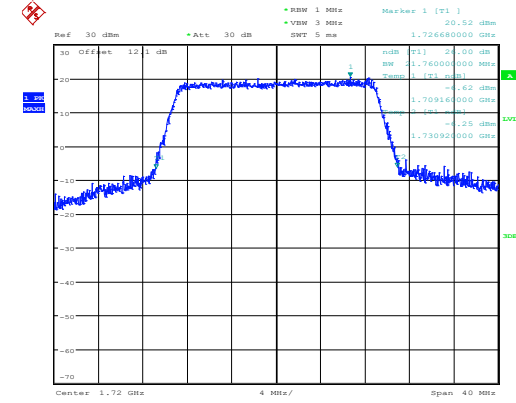

Date: 7.JAN.2015 22:51:42

Middle Channel / 20MHz / QPSK

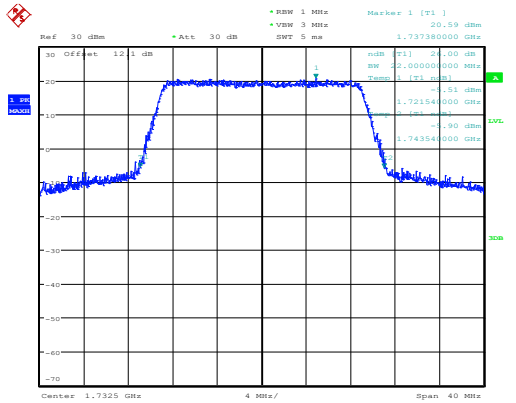

Date: 7.JAN.2015 22:59:20

Middle Channel / 20MHz / 16QAM

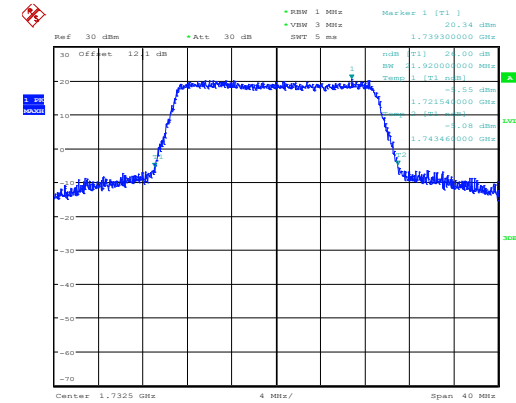

Date: 7.JAN.2015 22:59:32

Highest Channel / 20MHz / QPSK

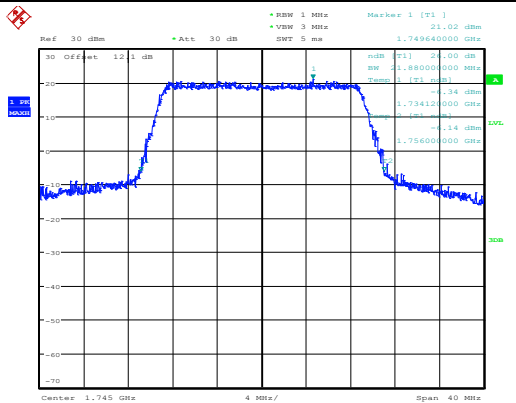

Date: 7.JAN.2015 23:02:28

Highest Channel / 20MHz / 16QAM

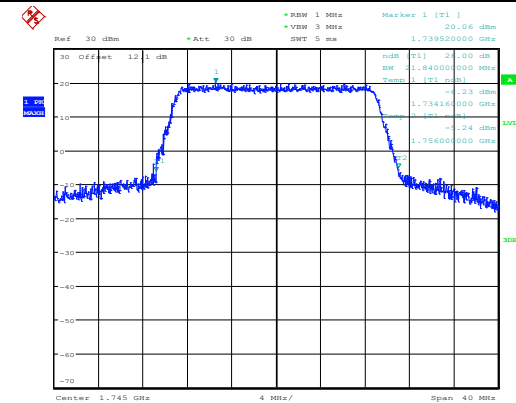

Date: 7.JAN.2015 23:02:40



LTE Band 13

Lowest Channel / 5MHz / QPSK

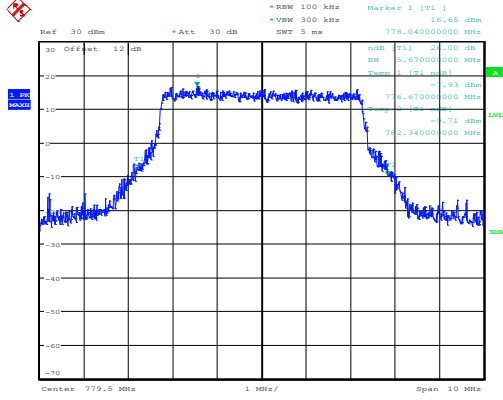

Date: 10.JAN.2015 00:45:31

Lowest Channel / 5MHz / 16QAM

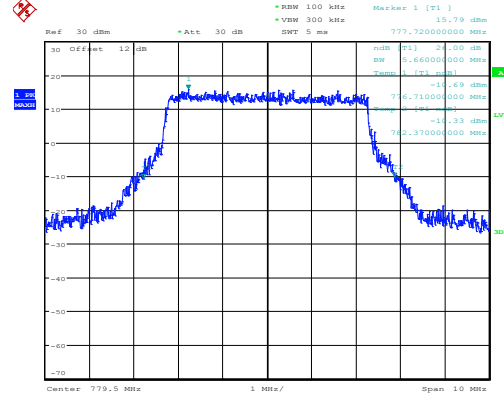

Date: 10.JAN.2015 00:45:17

Middle Channel / 5MHz / QPSK

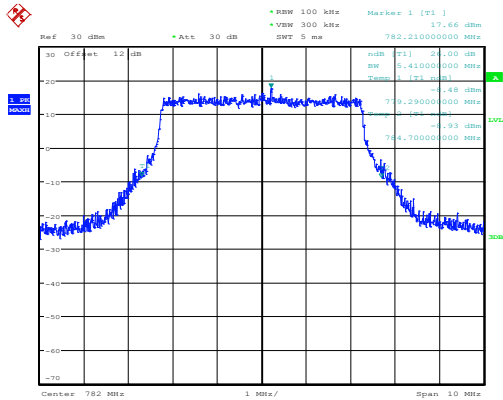

Date: 10.JAN.2015 00:45:46

Middle Channel / 5MHz / 16QAM

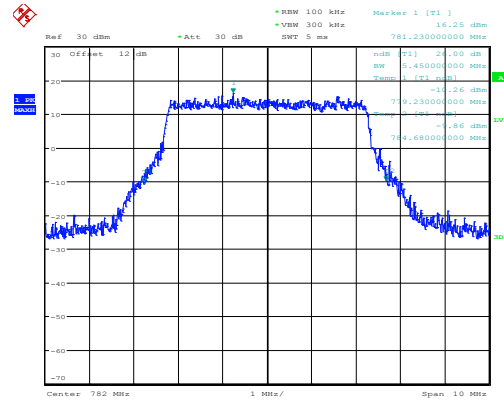

Date: 10.JAN.2015 00:46:01

Highest Channel / 5MHz / QPSK

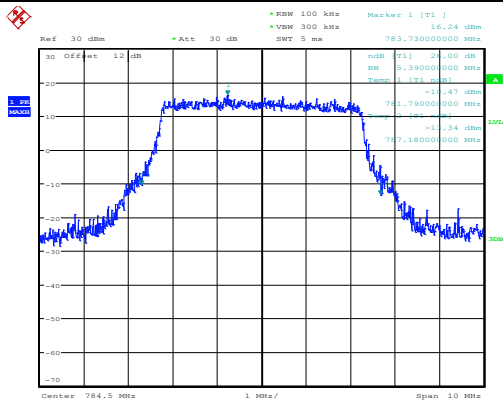

Date: 10.JAN.2015 00:47:20

Highest Channel / 5MHz / 16QAM

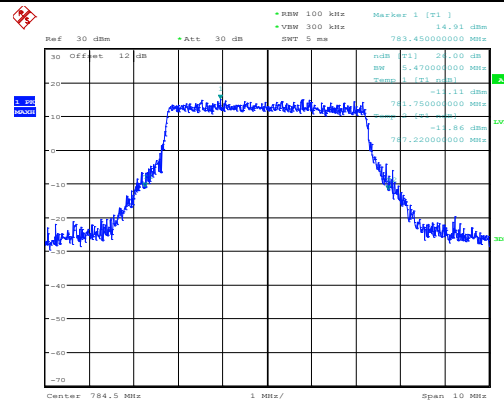

Date: 10.JAN.2015 00:47:06



LTE Band 13

Middle Channel / 10MHz / QPSK

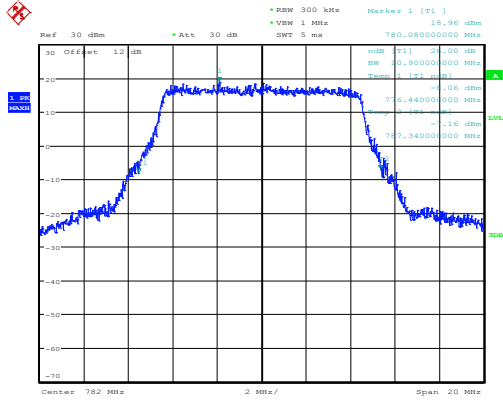

Date: 10.JAN.2015 00:53:36

Middle Channel / 10MHz / 16QAM

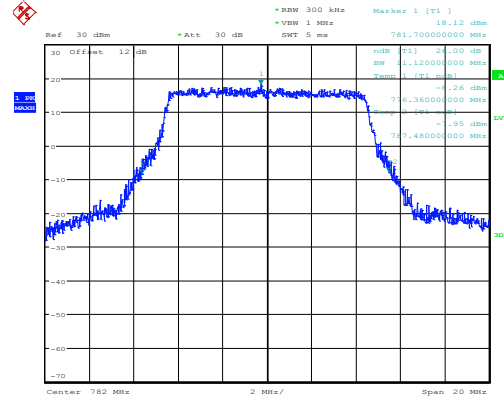

Date: 10.JAN.2015 00:53:21



Occupied Bandwidth

Mode	LTE Band 4 : 99%OBW(MHz)											
BW	1.4MHz		3MHz		5MHz		10MHz		15MHz		20MHz	
Mod.	QPSK	16QAM	QPSK	16QAM	QPSK	16QAM	QPSK	16QAM	QPSK	16QAM	QPSK	16QAM
Lowest CH	-	-	-	-	4.53	4.54	9.14	9.18	13.50	13.5	18.8	18.72
Middle CH	-	-	-	-	4.56	4.54	9.18	9.18	13.53	13.53	18.84	18.76
Highest CH	-	-	-	-	4.54	4.52	9.18	9.16	13.50	13.53	18.84	18.76

Mode	LTE Band 13 : 99%OBW(MHz)											
BW	1.4MHz		3MHz		5MHz		10MHz		15MHz		20MHz	
Mod.	QPSK	16QAM	QPSK	16QAM	QPSK	16QAM	QPSK	16QAM	QPSK	16QAM	QPSK	16QAM
Lowest CH	-	-	-	-	4.54	4.54	-	-	-	-	-	-
Middle CH	-	-	-	-	4.53	4.54	9.14	9.16	-	-	-	-
Highest CH	-	-	-	-	4.53	4.54	-	-	-	-	-	-



LTE Band 4

Lowest Channel / 5MHz / QPSK

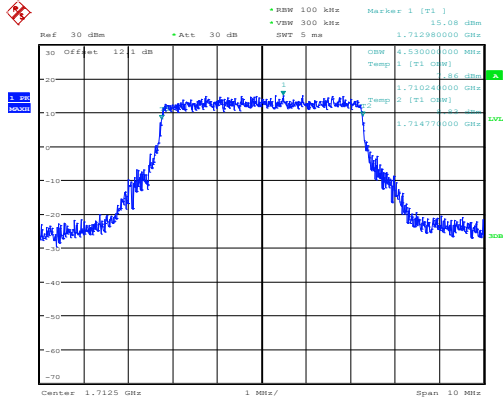

Date: 7.JAN.2015 21:52:12

Lowest Channel / 5MHz / 16QAM

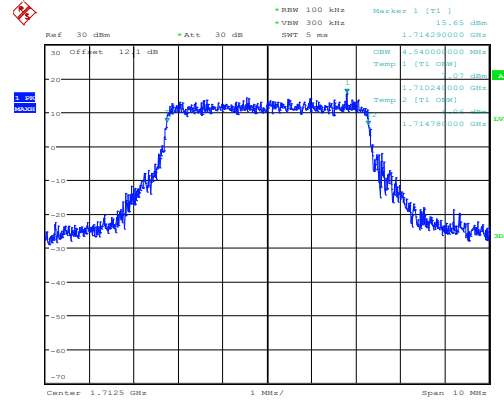

Date: 7.JAN.2015 21:52:23

Middle Channel / 5MHz / QPSK

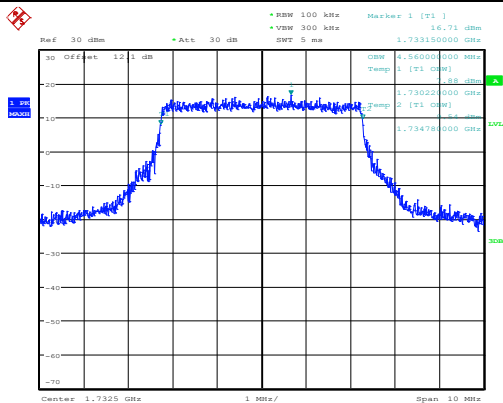

Date: 7.JAN.2015 22:00:05

Middle Channel / 5MHz / 16QAM

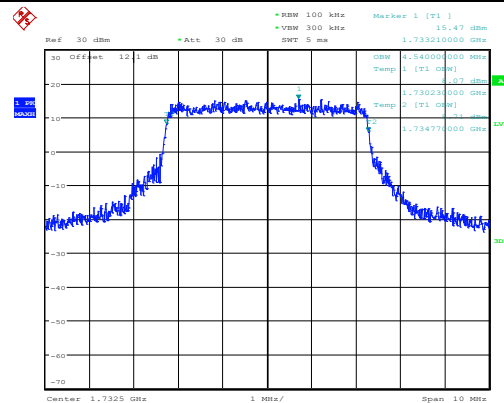

Date: 7.JAN.2015 22:00:16

Highest Channel / 5MHz / QPSK

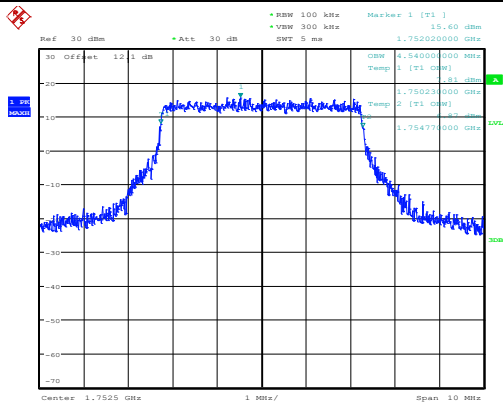

Date: 7.JAN.2015 22:03:14

Highest Channel / 5MHz / 16QAM

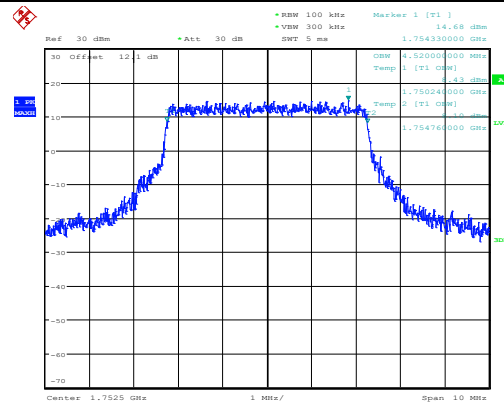

Date: 7.JAN.2015 22:03:24



LTE Band 4

Lowest Channel / 10MHz / QPSK

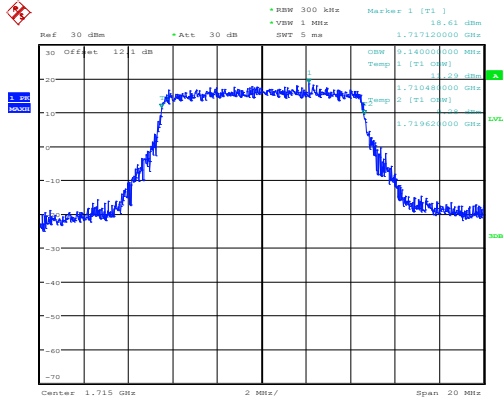

Date: 7.JAN.2015 22:11:20

Lowest Channel / 10MHz / 16QAM

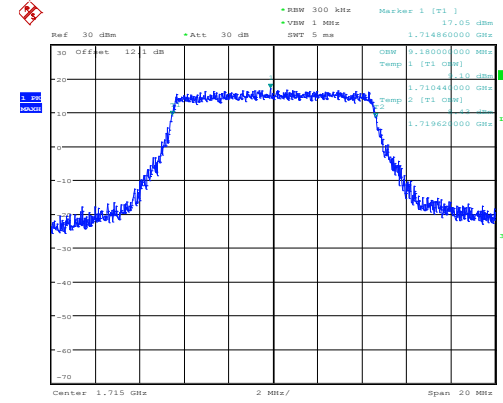

Date: 7.JAN.2015 22:12:44

Middle Channel / 10MHz / QPSK

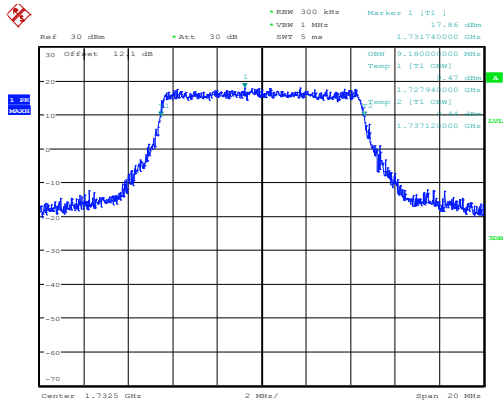

Date: 7.JAN.2015 22:20:32

Middle Channel / 10MHz / 16QAM

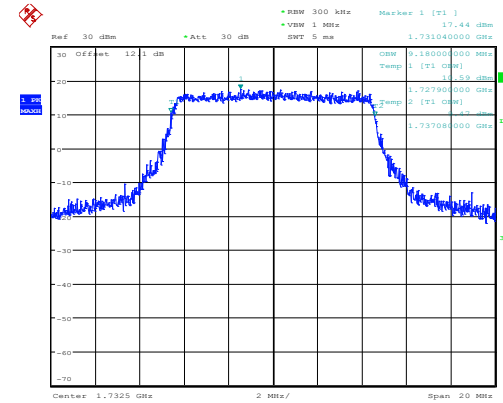

Date: 7.JAN.2015 22:20:42

Highest Channel / 10MHz / QPSK

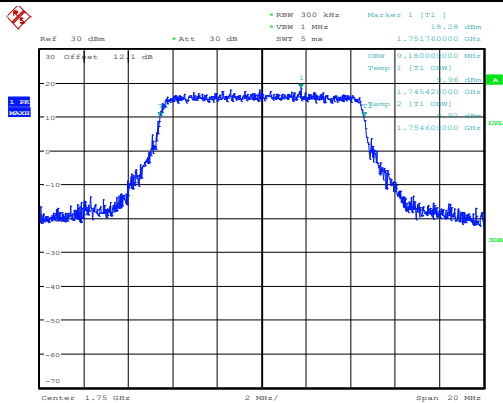

Date: 7.JAN.2015 22:23:37

Highest Channel / 10MHz / 16QAM

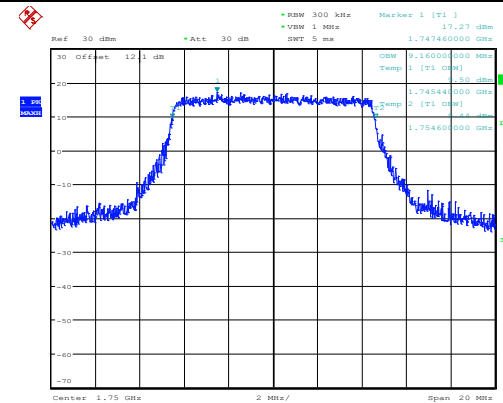

Date: 7.JAN.2015 22:23:47



LTE Band 4

Lowest Channel / 15MHz / QPSK

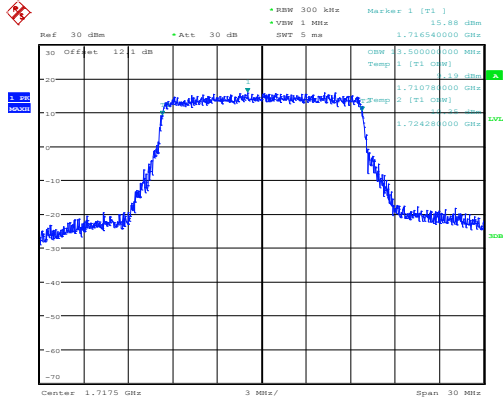

Date: 7.JAN.2015 22:31:46

Lowest Channel / 15MHz / 16QAM

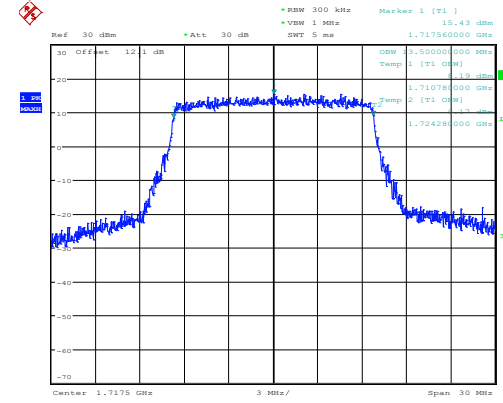

Date: 7.JAN.2015 22:31:57

Middle Channel / 15MHz / QPSK

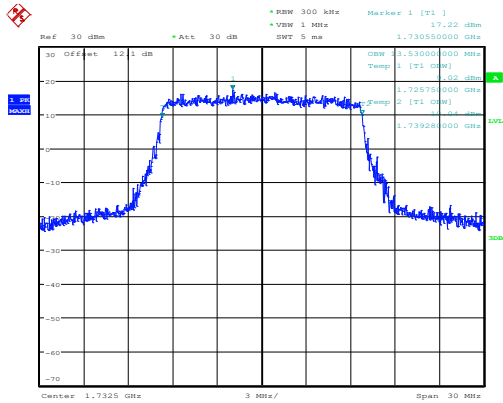

Date: 7.JAN.2015 22:39:37

Middle Channel / 15MHz / 16QAM

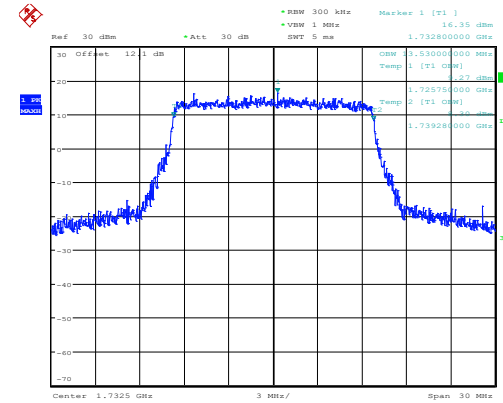

Date: 7.JAN.2015 22:39:48

Highest Channel / 15MHz / QPSK

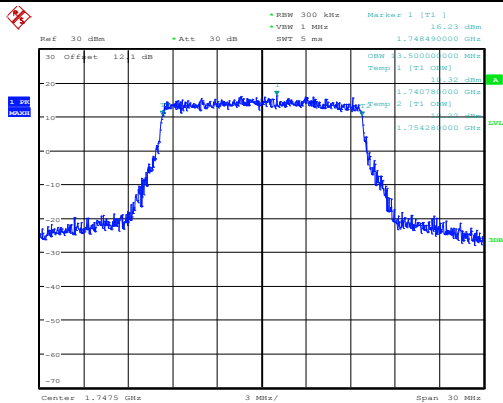

Date: 7.JAN.2015 22:42:46

Highest Channel / 15MHz / 16QAM

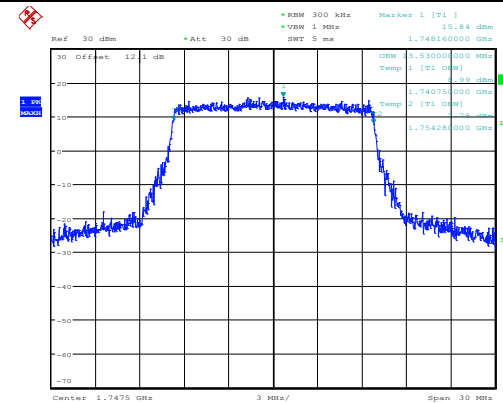

Date: 7.JAN.2015 22:42:57





LTE Band 4

Lowest Channel / 20MHz / QPSK

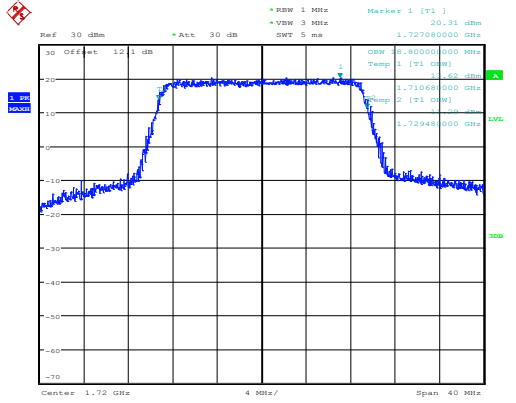

Date: 7.JAN.2015 22:51:06

Lowest Channel / 20MHz / 16QAM

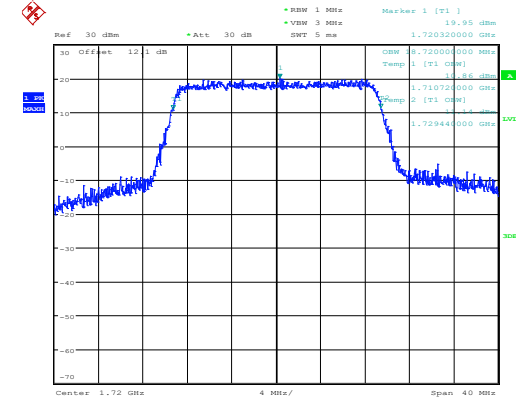

Date: 7.JAN.2015 22:51:17

Middle Channel / 20MHz / QPSK

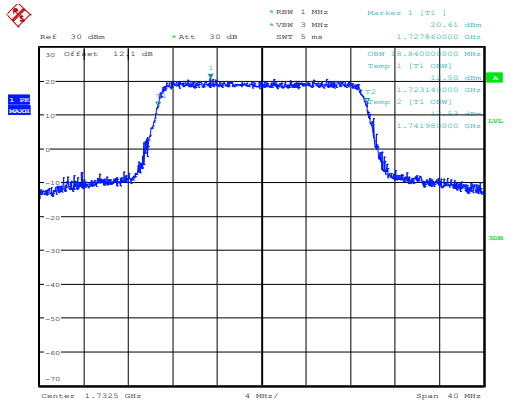

Date: 7.JAN.2015 22:58:56

Middle Channel / 20MHz / 16QAM

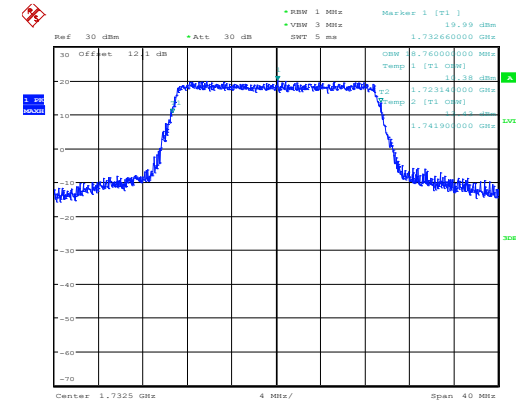

Date: 7.JAN.2015 22:59:07

Highest Channel / 20MHz / QPSK

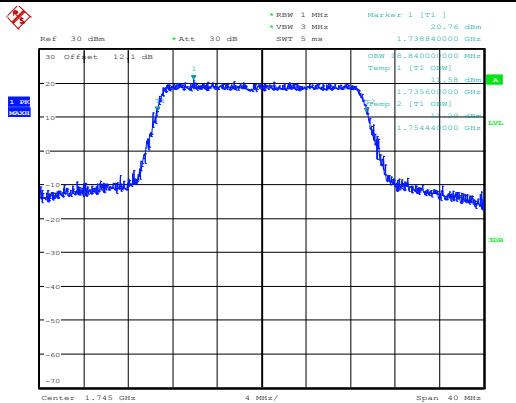

Date: 7.JAN.2015 23:02:04

Highest Channel / 20MHz / 16QAM

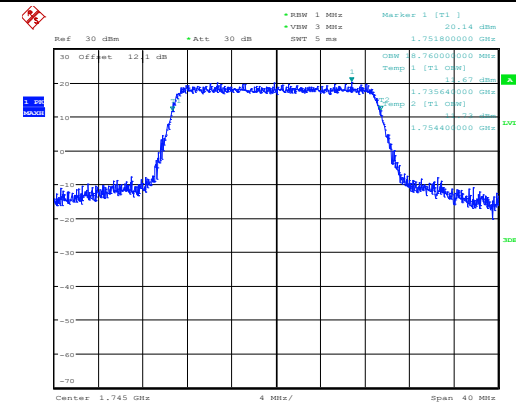

Date: 7.JAN.2015 23:02:15



LTE Band 13

Lowest Channel / 5MHz / QPSK

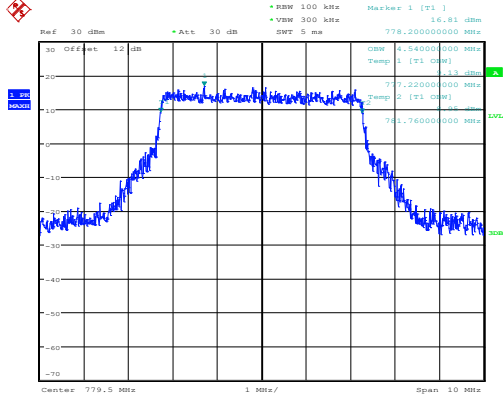

Date: 10.JAN.2015 00:44:49

Lowest Channel / 5MHz / 16QAM

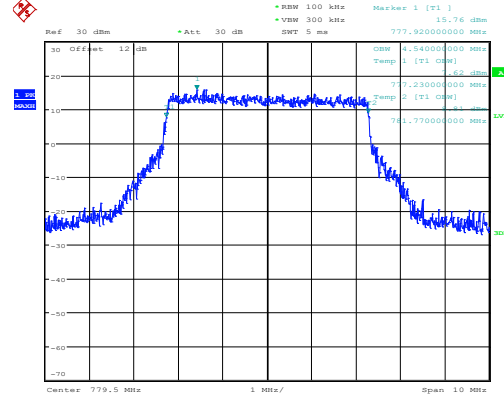

Date: 10.JAN.2015 00:45:02

Middle Channel / 5MHz / QPSK

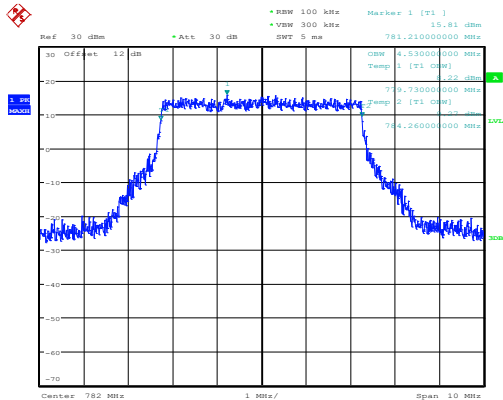

Date: 10.JAN.2015 00:46:26

Middle Channel / 5MHz / 16QAM

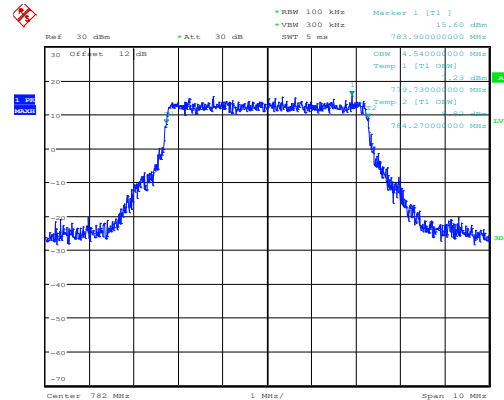

Date: 10.JAN.2015 00:46:13

Highest Channel / 5MHz / QPSK

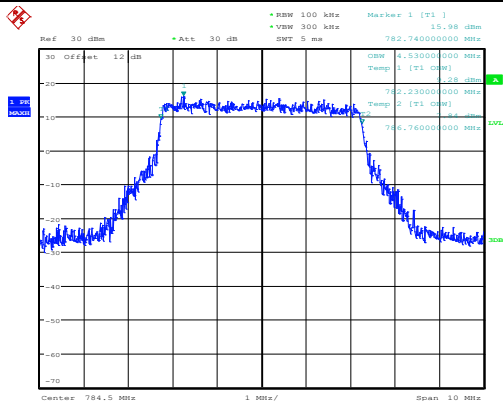

Date: 10.JAN.2015 00:46:38

Highest Channel / 5MHz / 16QAM

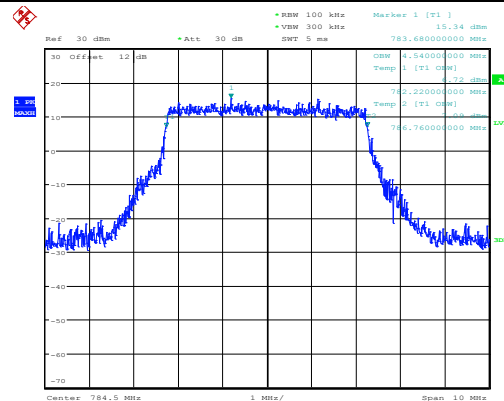

Date: 10.JAN.2015 00:46:51



LTE Band 13

Middle Channel / 10MHz / QPSK

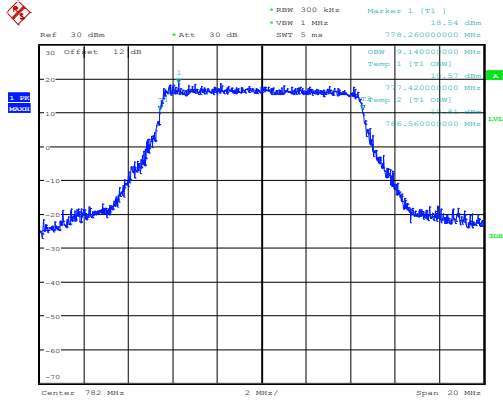

Date: 10.JAN.2015 00:55:32

Middle Channel / 10MHz / 16QAM

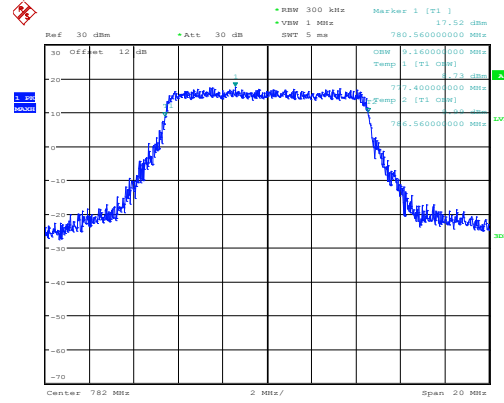

Date: 10.JAN.2015 00:53:06



# Conducted Band Edge

## LTE Band 4 / 5MHz / QPSK

### Lowest Band Edge / 1 RB

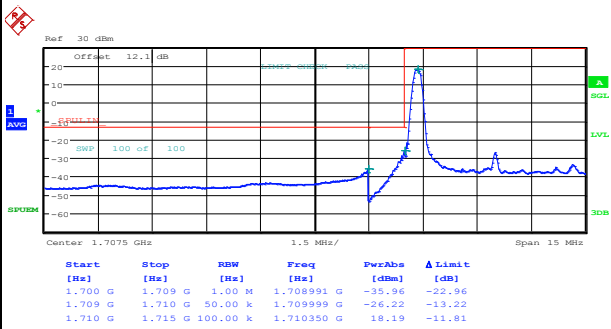

Date: 7.JAN.2015 21:53:59

### Highest Band Edge / 1 RB

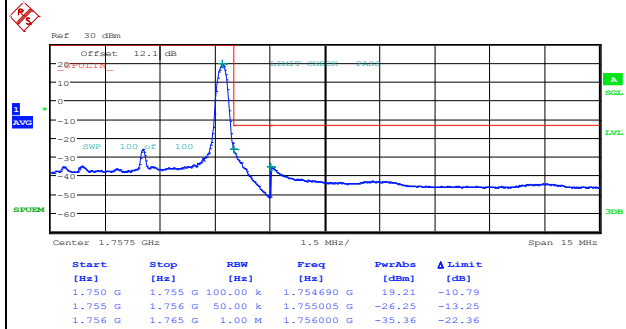

Date: 7.JAN.2015 22:05:00

### Lowest Band Edge / Full RB

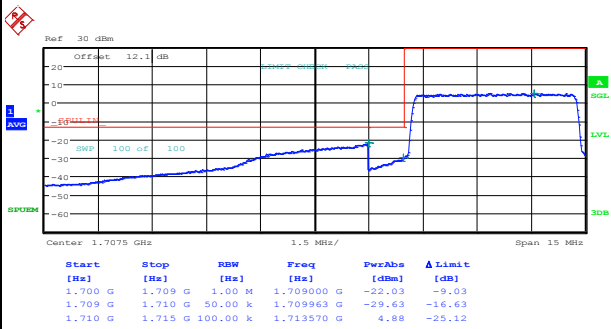

Date: 7.JAN.2015 21:56:20

### Highest Band Edge / Full RB

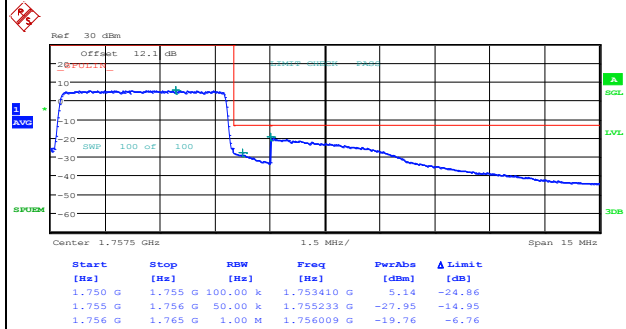

Date: 7.JAN.2015 22:07:21



LTE Band 4 / 5MHz / 16QAM

Lowest Band Edge / 1RB

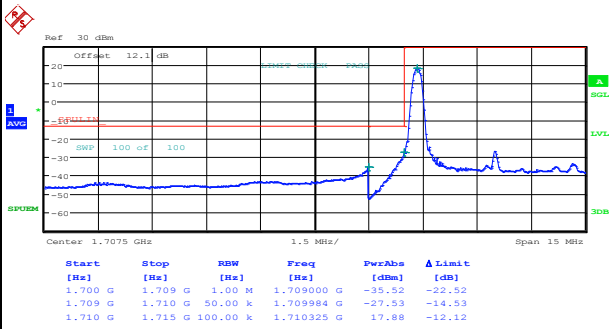

Date: 7.JAN.2015 21:55:10

Highest Band Edge / 1 RB

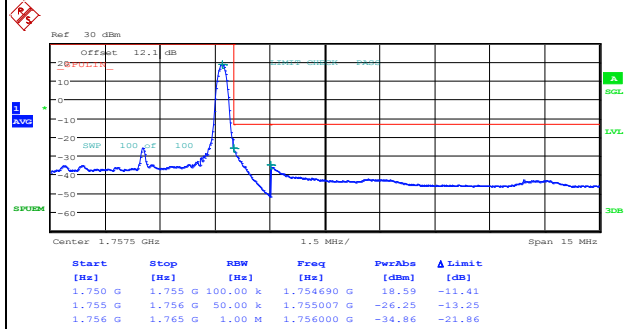

Date: 7.JAN.2015 22:06:11

Lowest Band Edge / Full RB

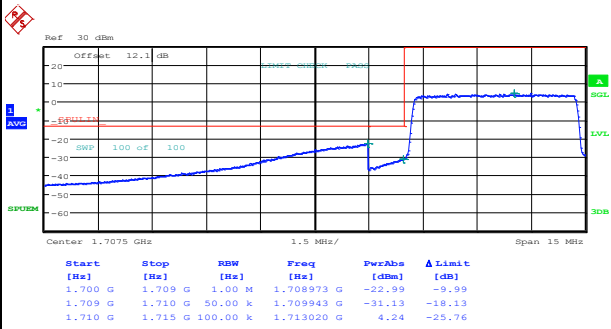

Date: 7.JAN.2015 21:57:33

Highest Band Edge / Full RB

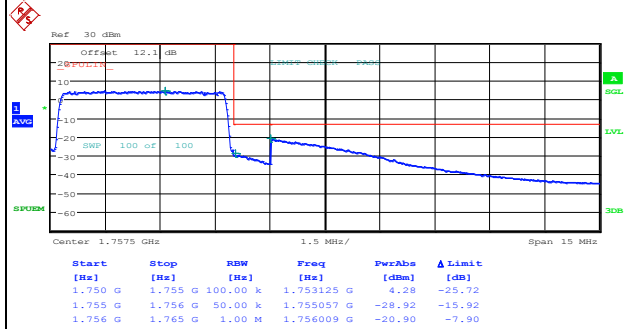

Date: 7.JAN.2015 22:08:31



LTE Band 4 / 10MHz / QPSK

Lowest Band Edge / 1 RB

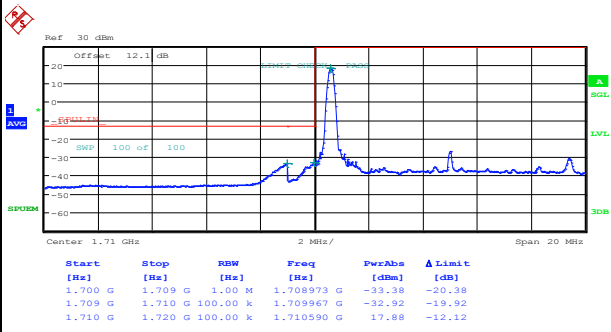

Date: 7.JAN.2015 22:14:31

Highest Band Edge / 1 RB

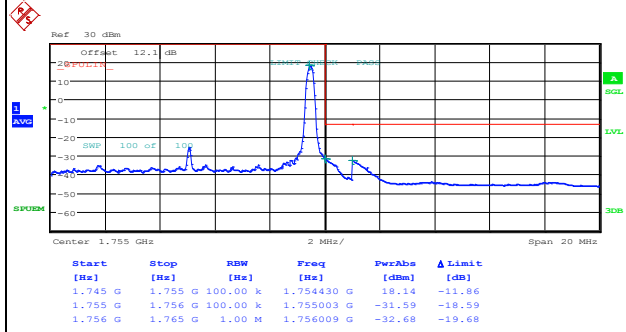

Date: 7.JAN.2015 22:25:21

Lowest Band Edge / Full RB

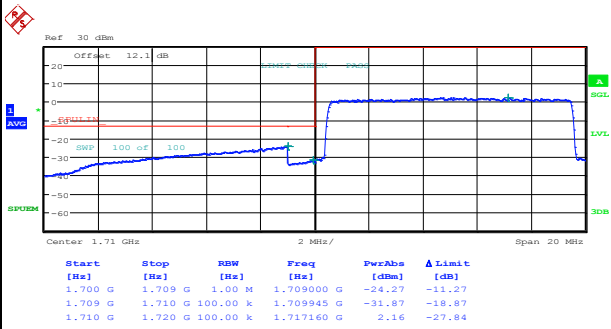

Date: 7.JAN.2015 22:16:51

Highest Band Edge / Full RB

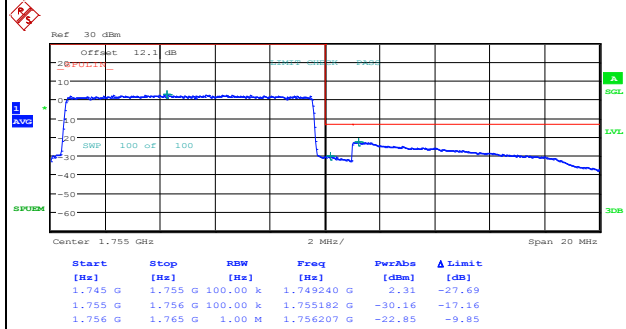

Date: 8.JAN.2015 00:00:52



LTE Band 4 / 10MHz / 16QAM

Lowest Band Edge / 1 RB

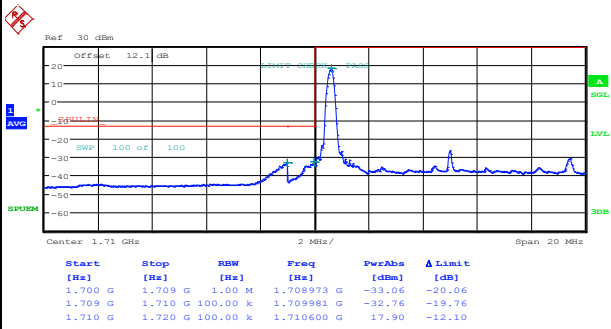

Date: 7.JAN.2015 22:15:41

Highest Band Edge / 1 RB

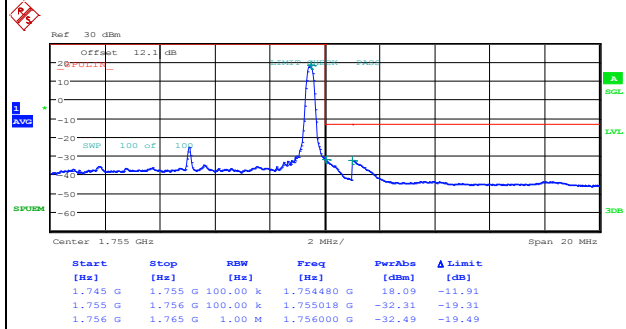

Date: 7.JAN.2015 22:16:31

Lowest Band Edge / Full RB

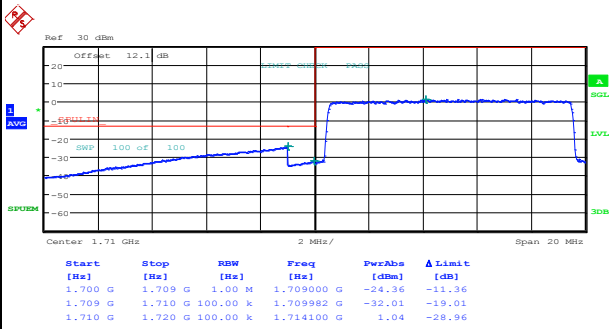

Date: 7.JAN.2015 22:18:01

Highest Band Edge / Full RB

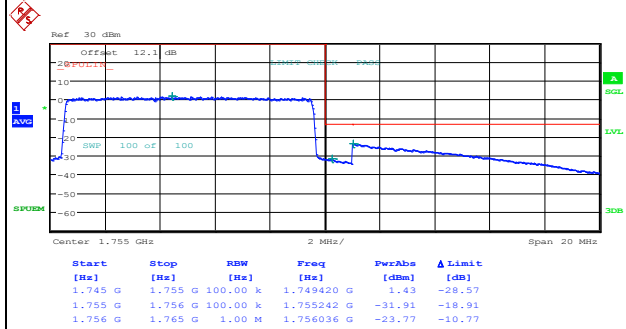

Date: 7.JAN.2015 22:18:58



LTE Band 4 / 15MHz / QPSK

Lowest Band Edge / 1 RB

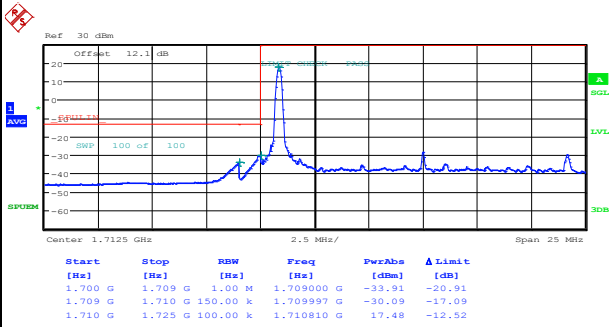

Date: 7.JAN.2015 22:33:33

Highest Band Edge / 1 RB

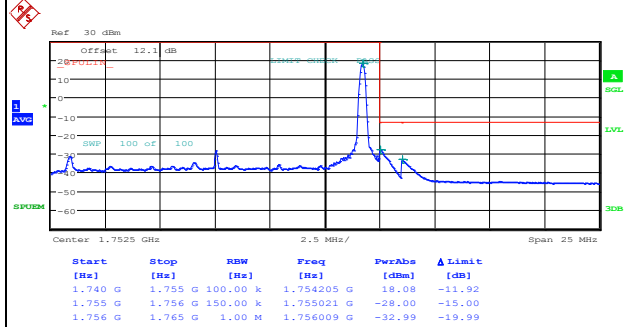

Date: 7.JAN.2015 22:44:33

Lowest Band Edge / Full RB

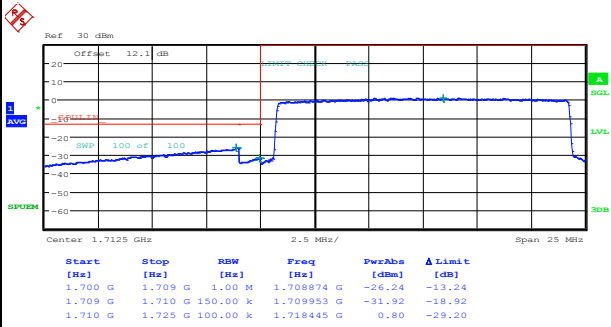

Date: 7.JAN.2015 22:35:54

Highest Band Edge / Full RB

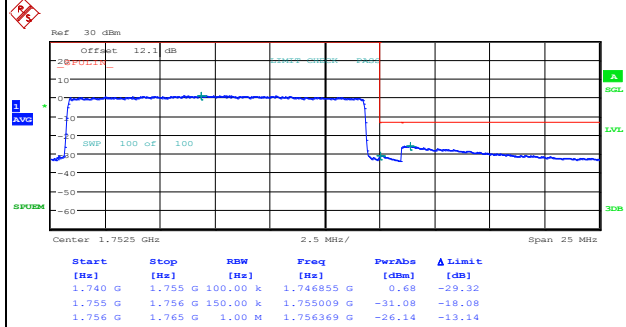

Date: 7.JAN.2015 22:46:53





LTE Band 4 / 15MHz / 16QAM

Lowest Band Edge / 1 RB

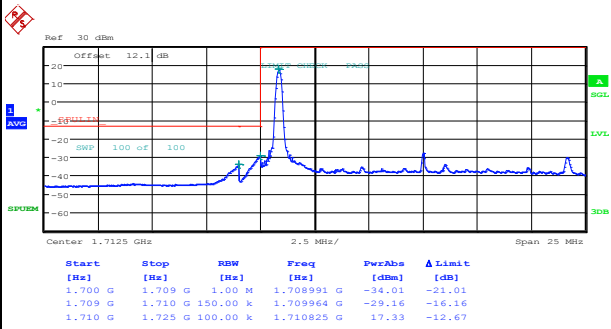

Date: 7.JAN.2015 22:34:44

Highest Band Edge / 1 RB

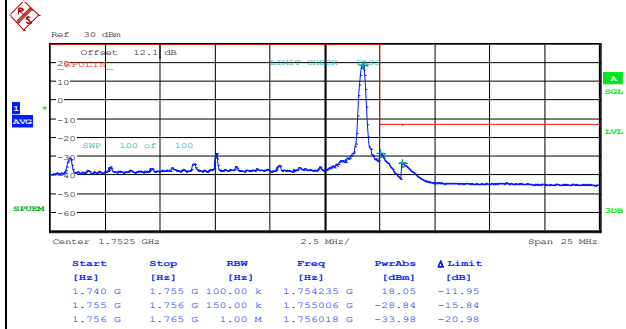

Date: 7.JAN.2015 22:45:43

Lowest Band Edge / Full RB

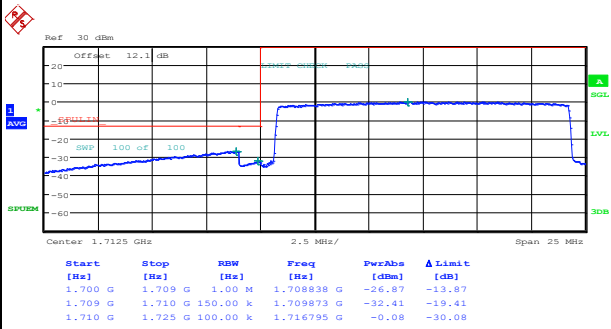

Date: 7.JAN.2015 22:37:05

Highest Band Edge / Full RB

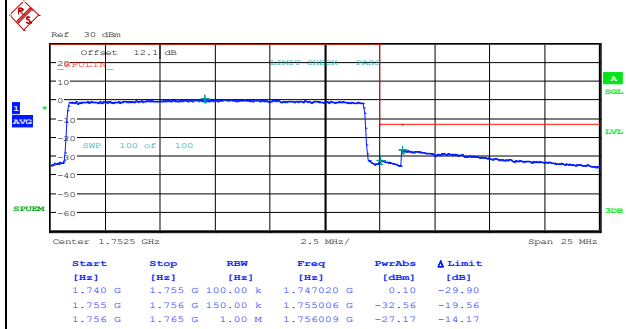

Date: 7.JAN.2015 22:48:04



LTE Band 4 / 20MHz / QPSK

Lowest Band Edge / 1 RB

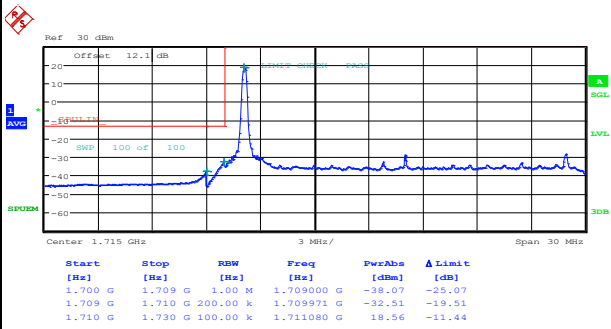

Date: 7.JAN.2015 22:52:52

Highest Band Edge / 1 RB

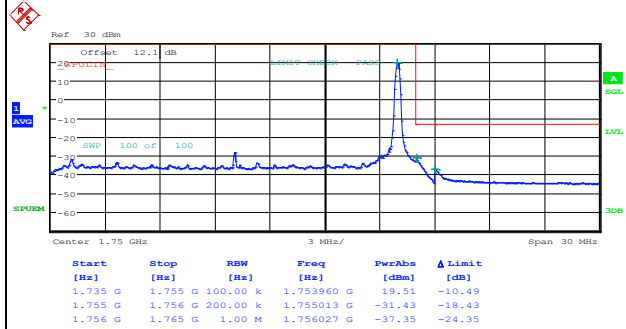

Date: 7.JAN.2015 23:03:51

Lowest Band Edge / Full RB

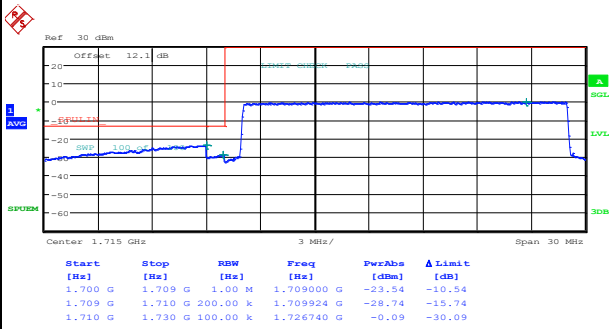

Date: 7.JAN.2015 22:55:13

Highest Band Edge / Full RB

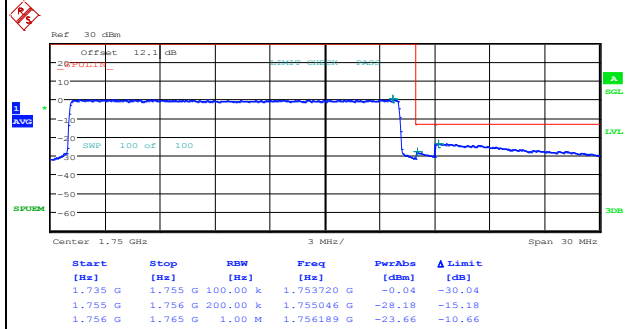

Date: 7.JAN.2015 23:06:11



LTE Band 4 / 20MHz / 16QAM

Lowest Band Edge / 1 RB

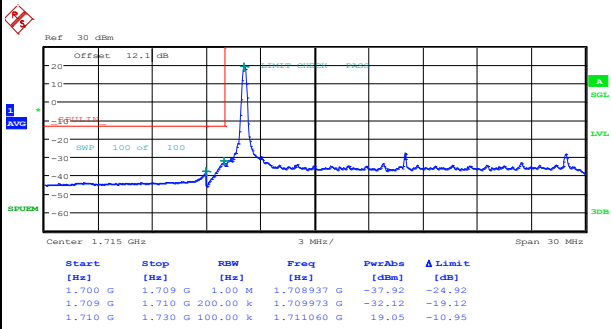

Date: 7.JAN.2015 22:54:03

Highest Band Edge / 1 RB

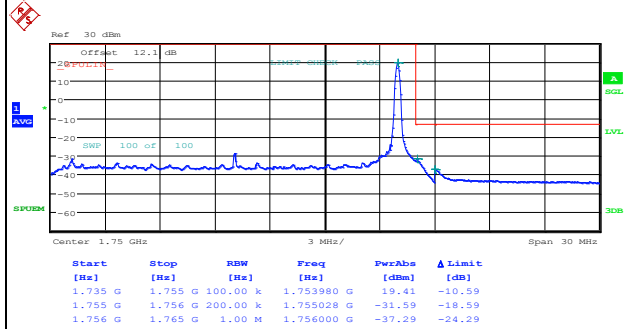

Date: 7.JAN.2015 23:05:01

Lowest Band Edge / Full RB

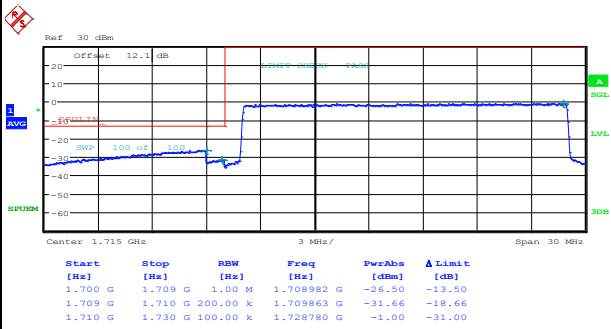

Date: 7.JAN.2015 22:56:24

Highest Band Edge / Full RB

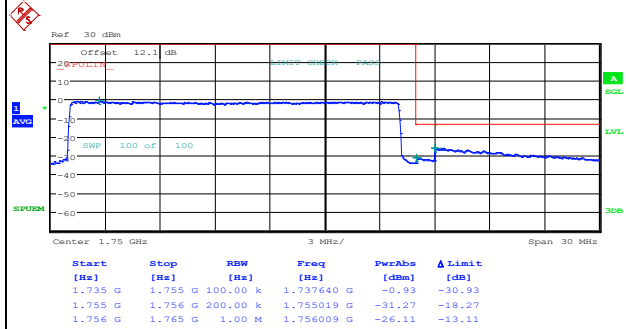

Date: 7.JAN.2015 23:07:22



LTE Band 13 / 5MHz / QPSK

Lowest Band Edge / 1 RB

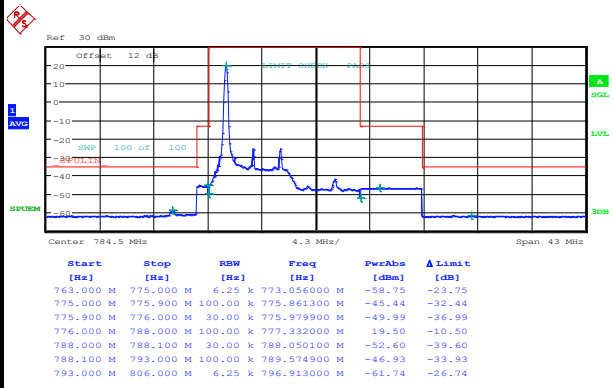

Date: 12.JAN.2015 09:35:21

Highest Band Edge / 1 RB

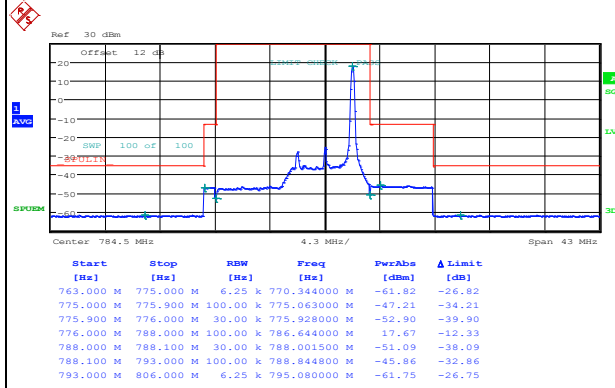

Date: 12.JAN.2015 09:51:52

Lowest Band Edge / Full RB

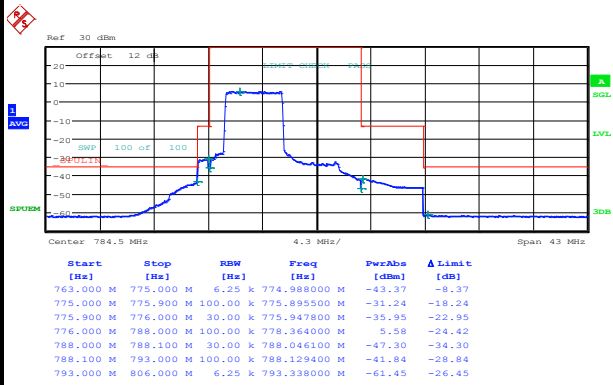

Date: 12.JAN.2015 09:42:07

Highest Band Edge / Full RB

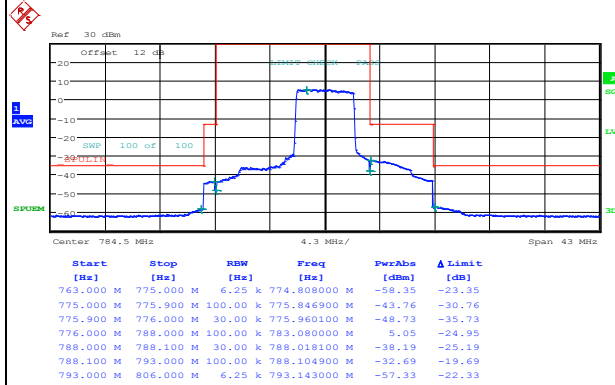

Date: 12.JAN.2015 09:44:28



LTE Band 13 / 5MHz / 16QAM

Lowest Band Edge / 1 RB

Highest Band Edge / 1 RB

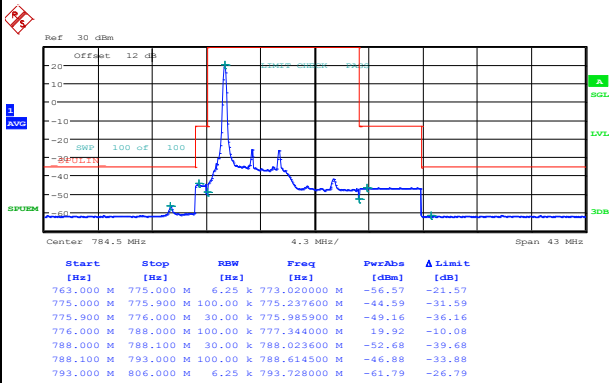

Date: 12.JAN.2015 09:37:49

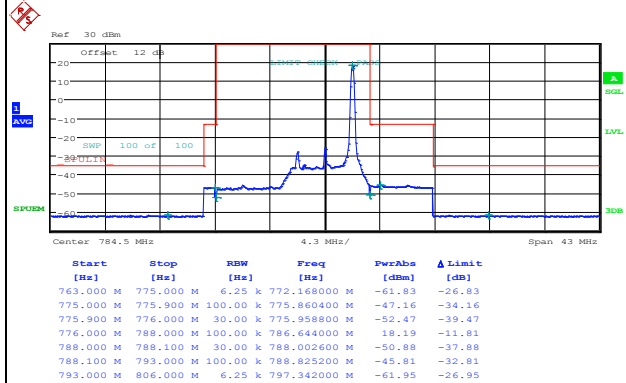

Date: 12.JAN.2015 09:49:32

Lowest Band Edge / Full RB

Highest Band Edge / Full RB

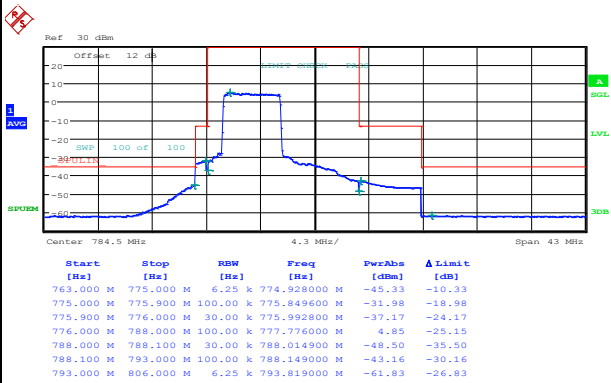

Date: 12.JAN.2015 09:40:15

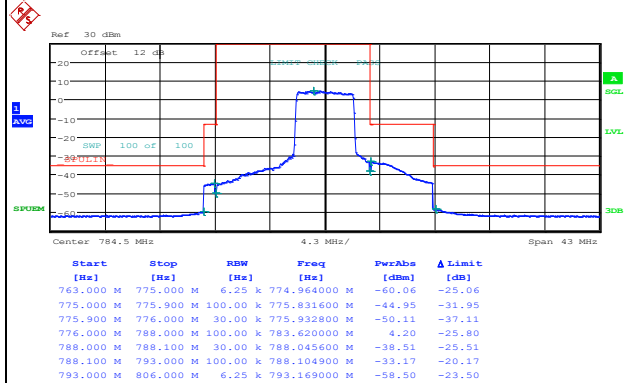

Date: 12.JAN.2015 09:47:14



LTE Band 13 / 10MHz / QPSK

Lowest Band Edge / 1 RB

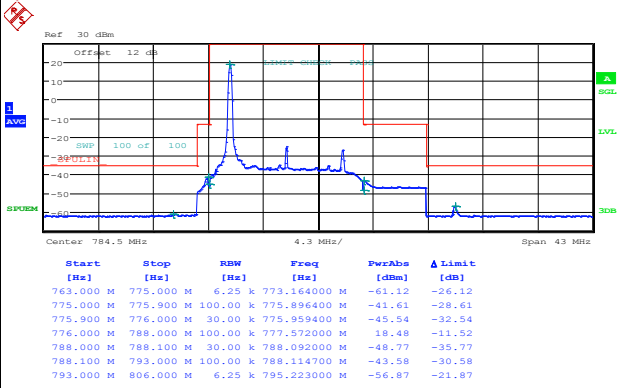

Date: 10.JAN.2015 01:19:12

Highest Band Edge / 1 RB

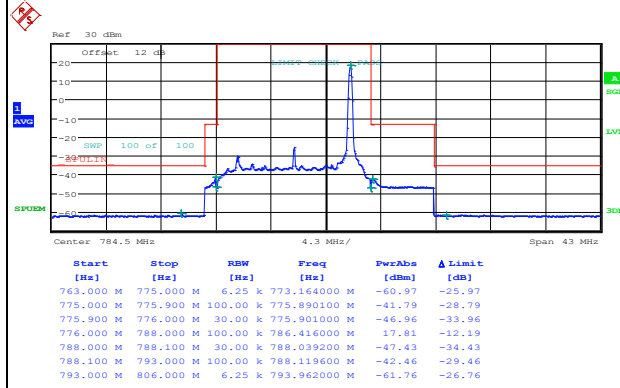

Date: 10.JAN.2015 01:26:42

Band Edge / Full RB

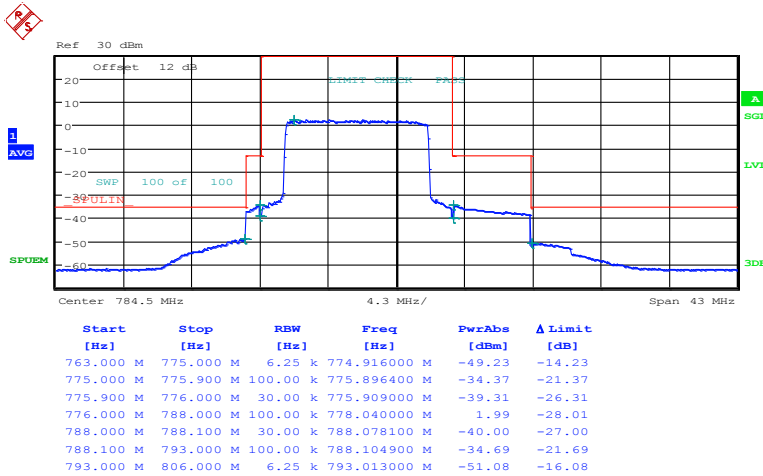

Date: 10.JAN.2015 01:16:52



LTE Band 13 / 10MHz / 16QAM

Lowest Band Edge / 1 RB

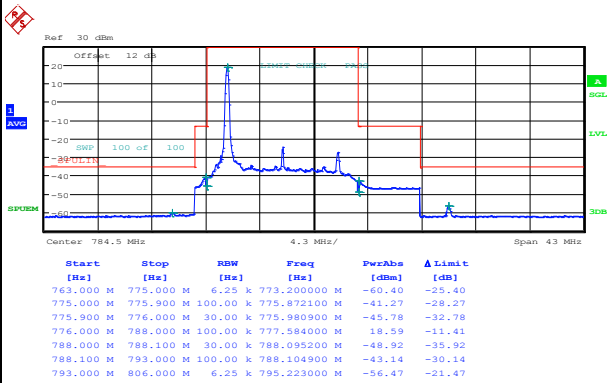

Date: 10.JAN.2015 01:21:22

Highest Band Edge / 1 RB

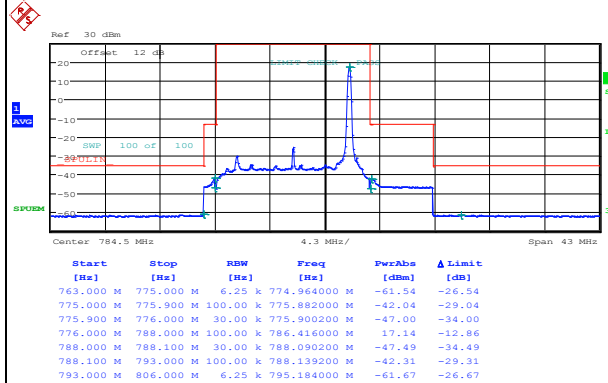

Date: 10.JAN.2015 01:24:02

Band Edge / Full RB

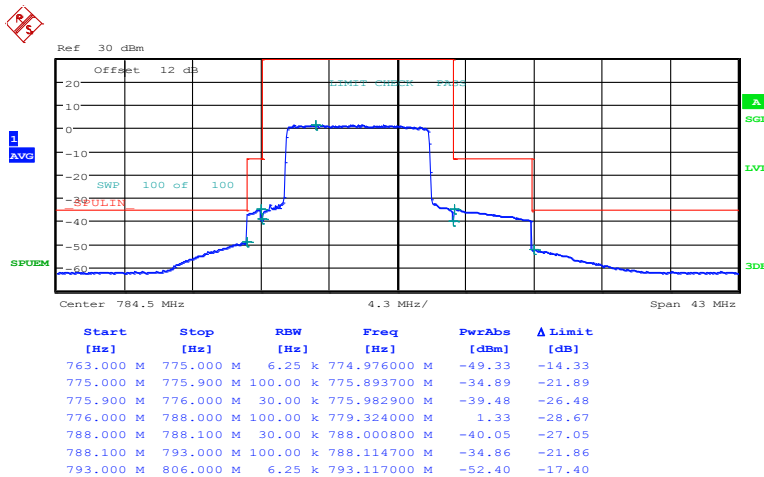

Date: 10.JAN.2015 01:14:29



# Conducted Spurious Emission

## LTE Band 4 / 5MHz

### Lowest Channel / QPSK

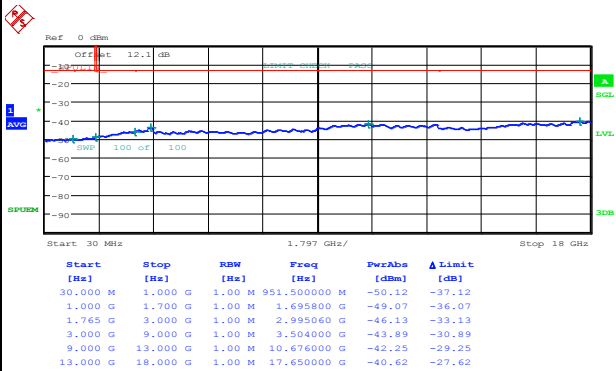

Date: 7.JAN.2015 21:58:43

### Lowest Channel / 16QAM

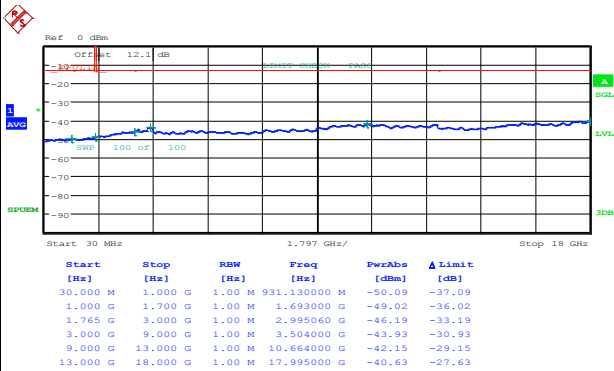

Date: 7.JAN.2015 21:59:54

### Middle Channel / QPSK

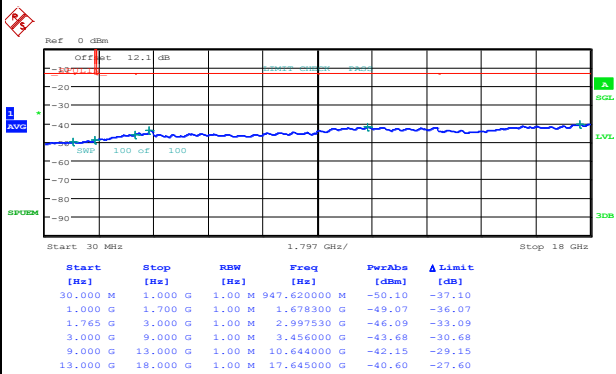

Date: 7.JAN.2015 22:01:52

### Middle Channel / 16QAM

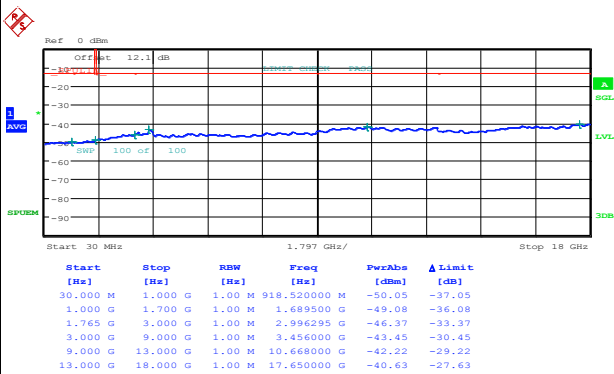

Date: 7.JAN.2015 22:03:02





LTE Band 4 / 5MHz

Highest Channel / QPSK

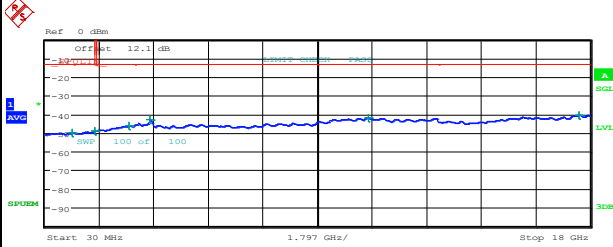

Start [Hz]	Stop [Hz]	RBW [Hz]	Freq [Hz]	PwrAbs [dBm]	Δ Limit [dB]
30.000 M	1.000 G	1.00 M	932.100000 M	-50.10	-37.10
1.000 G	1.700 G	1.00 M	1.679700 G	-49.19	-36.19
1.765 G	3.000 G	1.00 M	2.804870 G	-46.22	-33.22
3.000 G	9.000 G	1.00 M	3.498000 G	-42.74	-29.74
9.000 G	13.000 G	1.00 M	10.672000 G	-42.18	-29.18
13.000 G	18.000 G	1.00 M	17.635000 G	-40.57	-27.57

Date: 7.JAN.2015 22:09:40

Highest Channel / 16QAM

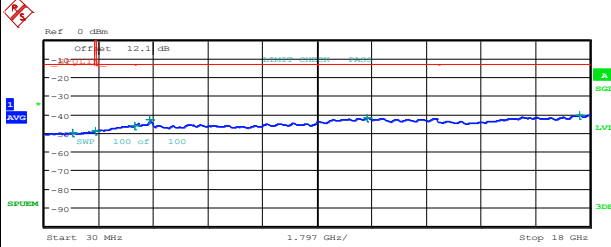

Start [Hz]	Stop [Hz]	RBW [Hz]	Freq [Hz]	PwrAbs [dBm]	Δ Limit [dB]
30.000 M	1.000 G	1.00 M	956.350000 M	-50.10	-37.10
1.000 G	1.700 G	1.00 M	1.691600 G	-49.12	-36.12
1.765 G	3.000 G	1.00 M	2.988885 G	-46.24	-33.24
3.000 G	9.000 G	1.00 M	3.498000 G	-42.86	-29.86
9.000 G	13.000 G	1.00 M	10.648000 G	-42.19	-29.19
13.000 G	18.000 G	1.00 M	17.645000 G	-40.67	-27.67

Date: 7.JAN.2015 22:10:50

LTE Band 4 / 10MHz

Lowest Channel / QPSK

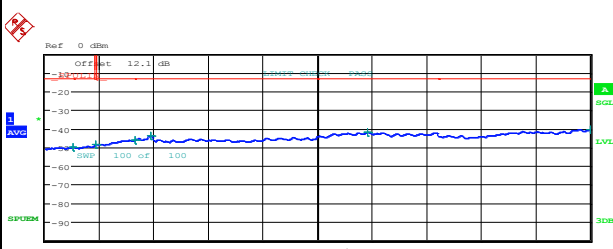

Start [Hz]	Stop [Hz]	RBW [Hz]	Freq [Hz]	PwrAbs [dBm]	Δ Limit [dB]
30.000 M	1.000 G	1.00 M	963.140000 M	-50.02	-37.02
1.000 G	1.700 G	1.00 M	1.693000 G	-48.56	-35.56
1.765 G	3.000 G	1.00 M	2.986415 G	-46.28	-33.28
3.000 G	9.000 G	1.00 M	3.504000 G	-43.95	-30.95
9.000 G	13.000 G	1.00 M	10.668000 G	-42.12	-29.12
13.000 G	18.000 G	1.00 M	17.995000 G	-40.67	-27.67

Date: 7.JAN.2015 22:19:11

Lowest Channel / 16QAM

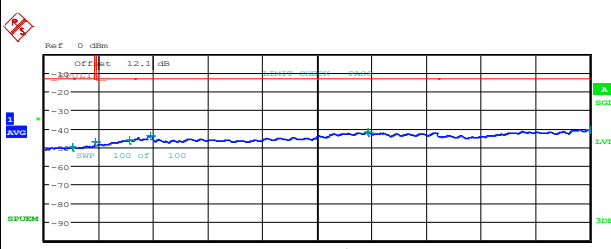

Start [Hz]	Stop [Hz]	RBW [Hz]	Freq [Hz]	PwrAbs [dBm]	Δ Limit [dB]
30.000 M	1.000 G	1.00 M	949.560000 M	-50.09	-37.09
1.000 G	1.700 G	1.00 M	1.693700 G	-47.40	-34.40
1.765 G	3.000 G	1.00 M	2.809810 G	-46.20	-33.20
3.000 G	9.000 G	1.00 M	3.516000 G	-43.93	-30.93
9.000 G	13.000 G	1.00 M	10.672000 G	-42.22	-29.22
13.000 G	18.000 G	1.00 M	17.990000 G	-40.66	-27.66

Date: 7.JAN.2015 22:20:21



LTE Band 4 / 10MHz

Middle Channel / QPSK

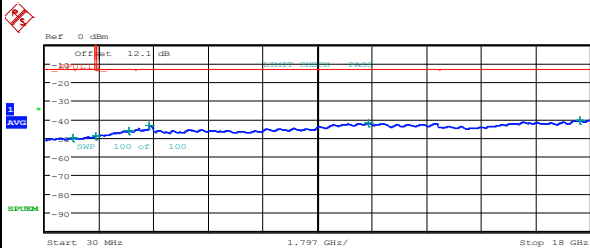

Start [Hz]	Stop [Hz]	RBW [Hz]	Freq [Hz]	PwrAbs [dBm]	Δ Limit [dB]
30.000 M	1.000 G	1.00 M	948.590000 M	-50.08	-37.08
1.000 G	1.700 G	1.00 M	1.698600 G	-49.13	-36.13
1.765 G	3.000 G	1.00 M	2.798695 G	-46.26	-33.26
3.000 G	9.000 G	1.00 M	3.456000 G	-43.33	-30.33
9.000 G	13.000 G	1.00 M	10.672000 G	-42.17	-29.17
13.000 G	18.000 G	1.00 M	17.655000 G	-40.66	-27.66

Date: 7.JAN.2015 22:22:16

Middle Channel / 16QAM

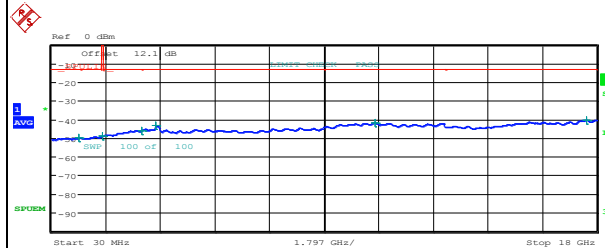

Start [Hz]	Stop [Hz]	RBW [Hz]	Freq [Hz]	PwrAbs [dBm]	Δ Limit [dB]
30.000 M	1.000 G	1.00 M	909.790000 M	-50.08	-37.08
1.000 G	1.700 G	1.00 M	1.698600 G	-48.90	-35.90
1.765 G	3.000 G	1.00 M	2.993825 G	-46.27	-33.27
3.000 G	9.000 G	1.00 M	3.456000 G	-43.23	-30.23
9.000 G	13.000 G	1.00 M	10.676000 G	-42.33	-29.33
13.000 G	18.000 G	1.00 M	17.655000 G	-40.60	-27.60

Date: 7.JAN.2015 22:23:26

Highest Channel / QPSK

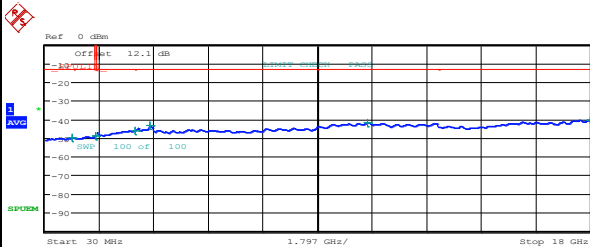

Start [Hz]	Stop [Hz]	RBW [Hz]	Freq [Hz]	PwrAbs [dBm]	Δ Limit [dB]
30.000 M	1.000 G	1.00 M	912.700000 M	-50.11	-37.11
1.000 G	1.700 G	1.00 M	1.696500 G	-49.11	-36.11
1.765 G	3.000 G	1.00 M	2.995060 G	-46.16	-33.16
3.000 G	9.000 G	1.00 M	3.492000 G	-43.57	-30.57
9.000 G	13.000 G	1.00 M	10.652000 G	-42.14	-29.14
13.000 G	18.000 G	1.00 M	17.995000 G	-40.65	-27.65

Date: 7.JAN.2015 22:30:08

Highest Channel / 16QAM

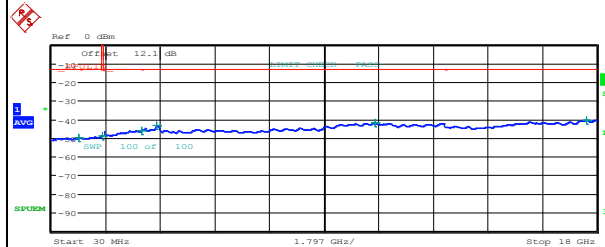

Start [Hz]	Stop [Hz]	RBW [Hz]	Freq [Hz]	PwrAbs [dBm]	Δ Limit [dB]
30.000 M	1.000 G	1.00 M	927.250000 M	-50.00	-37.00
1.000 G	1.700 G	1.00 M	1.698600 G	-49.06	-36.06
1.765 G	3.000 G	1.00 M	2.998765 G	-46.30	-33.30
3.000 G	9.000 G	1.00 M	3.492000 G	-43.56	-30.56
9.000 G	13.000 G	1.00 M	10.676000 G	-42.20	-29.20
13.000 G	18.000 G	1.00 M	17.655000 G	-40.70	-27.70

Date: 7.JAN.2015 22:31:19



LTE Band 4 / 15MHz

Lowest Channel / QPSK

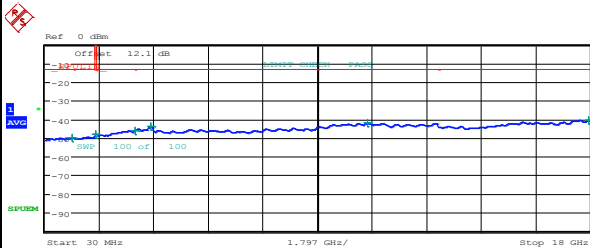

Start [Hz]	Stop [Hz]	RBW [Hz]	Freq [Hz]	PwrAbs [dBm]	Δ Limit [dB]
30.000 M	1.000 G	1.00 M	916.580000 M	-50.10	-37.10
1.000 G	1.700 G	1.00 M	1.697900 G	-48.01	-35.01
1.765 G	3.000 G	1.00 M	2.992590 G	-46.34	-33.34
3.000 G	9.000 G	1.00 M	3.504000 G	-43.95	-30.95
9.000 G	13.000 G	1.00 M	10.668000 G	-42.19	-29.19
13.000 G	18.000 G	1.00 M	17.940000 G	-40.69	-27.69

Date: 7.JAN.2015 22:38:15

Lowest Channel / 16QAM

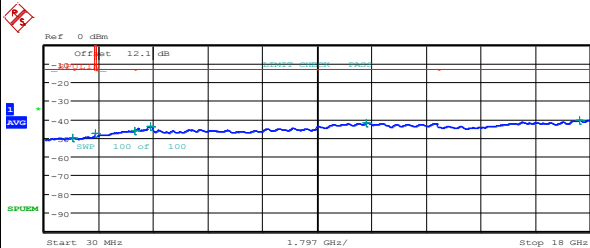

Start [Hz]	Stop [Hz]	RBW [Hz]	Freq [Hz]	PwrAbs [dBm]	Δ Limit [dB]
30.000 M	1.000 G	1.00 M	938.890000 M	-50.02	-37.02
1.000 G	1.700 G	1.00 M	1.697900 G	-47.55	-34.55
1.765 G	3.000 G	1.00 M	2.997530 G	-46.28	-33.28
3.000 G	9.000 G	1.00 M	3.522000 G	-43.94	-30.94
9.000 G	13.000 G	1.00 M	10.640000 G	-42.17	-29.17
13.000 G	18.000 G	1.00 M	17.665000 G	-40.62	-27.62

Date: 7.JAN.2015 22:39:26

Middle Channel / QPSK

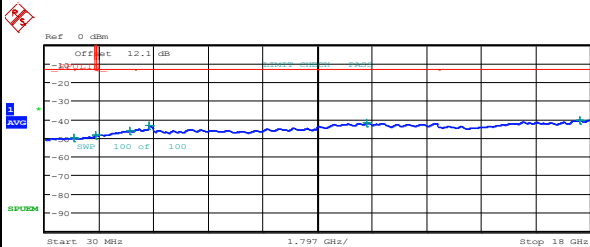

Start [Hz]	Stop [Hz]	RBW [Hz]	Freq [Hz]	PwrAbs [dBm]	Δ Limit [dB]
30.000 M	1.000 G	1.00 M	969.930000 M	-50.10	-37.10
1.000 G	1.700 G	1.00 M	1.699300 G	-48.67	-35.67
1.765 G	3.000 G	1.00 M	2.812280 G	-46.12	-33.12
3.000 G	9.000 G	1.00 M	3.450000 G	-43.34	-30.34
9.000 G	13.000 G	1.00 M	10.636000 G	-42.21	-29.21
13.000 G	18.000 G	1.00 M	17.665000 G	-40.66	-27.66

Date: 7.JAN.2015 22:41:24

Middle Channel / 16QAM

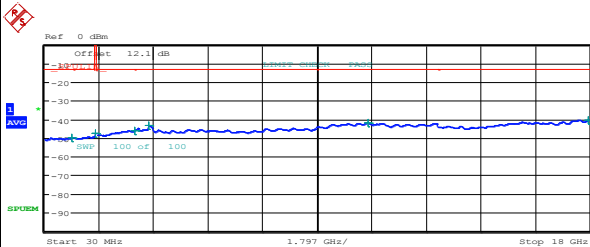

Start [Hz]	Stop [Hz]	RBW [Hz]	Freq [Hz]	PwrAbs [dBm]	Δ Limit [dB]
30.000 M	1.000 G	1.00 M	926.280000 M	-50.08	-37.08
1.000 G	1.700 G	1.00 M	1.699300 G	-47.87	-34.87
1.765 G	3.000 G	1.00 M	2.992590 G	-46.30	-33.30
3.000 G	9.000 G	1.00 M	3.450000 G	-43.32	-30.32
9.000 G	13.000 G	1.00 M	10.676000 G	-42.15	-29.15
13.000 G	18.000 G	1.00 M	17.930000 G	-40.67	-27.67

Date: 7.JAN.2015 22:42:35



LTE Band 4 / 15MHz

Highest Channel / QPSK

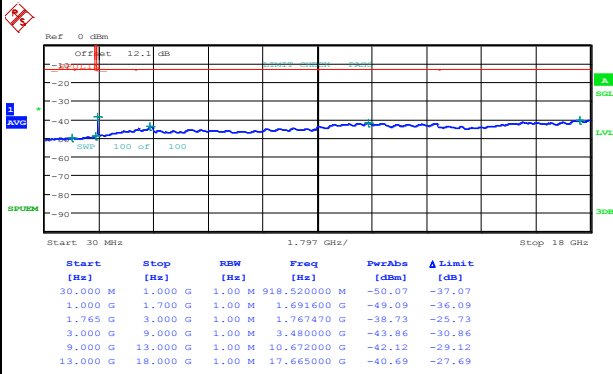

Date: 7.JAN.2015 22:49:14

Highest Channel / 16QAM

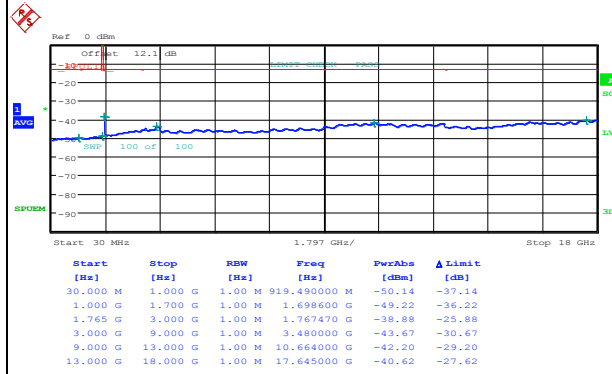

Date: 7.JAN.2015 22:50:25

LTE Band 4 / 20MHz

Lowest Channel / QPSK

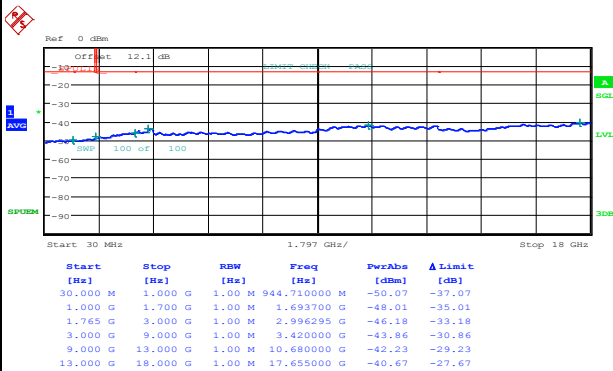

Date: 7.JAN.2015 22:57:34

Lowest Channel / 16QAM

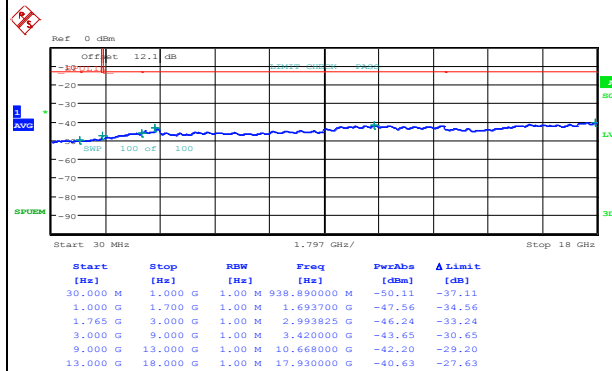

Date: 7.JAN.2015 22:58:45



LTE Band 4 / 20MHz

Middle Channel / QPSK

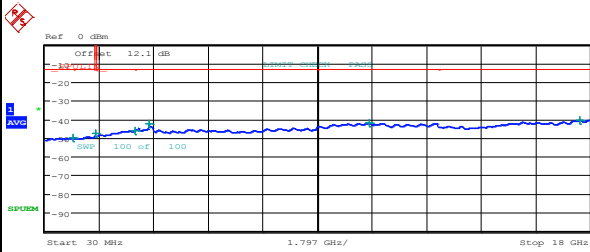

Start [Hz]	Stop [Hz]	RBW [Hz]	Freq [Hz]	PwrAbs [dBm]	Δ Limit [dB]
30.000 M	1.000 G	1.00 M	960.230000 M	-50.16	-37.16
1.000 G	1.700 G	1.00 M	1.688800 G	-47.71	-34.71
1.765 G	3.000 G	1.00 M	2.997530 G	-46.34	-33.34
3.000 G	9.000 G	1.00 M	3.444000 G	-42.47	-29.47
9.000 G	13.000 G	1.00 M	10.700000 G	-42.23	-29.23
13.000 G	18.000 G	1.00 M	17.655000 G	-40.61	-27.61

Date: 7.JAN.2015 23:00:43

Middle Channel / 16QAM

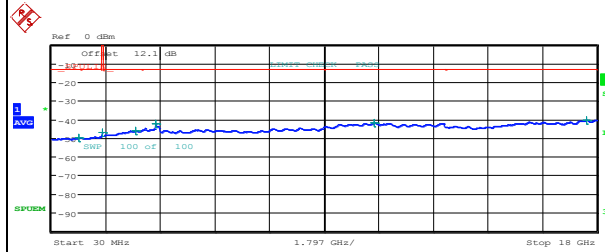

Start [Hz]	Stop [Hz]	RBW [Hz]	Freq [Hz]	PwrAbs [dBm]	Δ Limit [dB]
30.000 M	1.000 G	1.00 M	933.070000 M	-50.12	-37.12
1.000 G	1.700 G	1.00 M	1.688100 G	-47.16	-34.16
1.765 G	3.000 G	1.00 M	2.807340 G	-46.10	-33.10
3.000 G	9.000 G	1.00 M	3.444000 G	-42.28	-29.28
9.000 G	13.000 G	1.00 M	10.664000 G	-42.22	-29.22
13.000 G	18.000 G	1.00 M	17.655000 G	-40.57	-27.57

Date: 7.JAN.2015 23:01:53

Highest Channel / QPSK

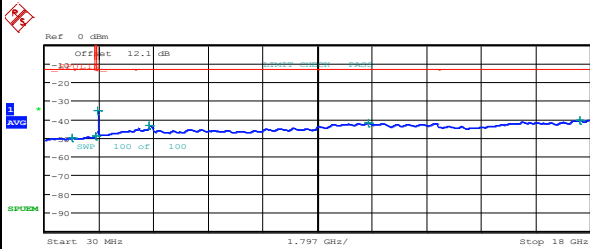

Start [Hz]	Stop [Hz]	RBW [Hz]	Freq [Hz]	PwrAbs [dBm]	Δ Limit [dB]
30.000 M	1.000 G	1.00 M	922.400000 M	-50.04	-37.04
1.000 G	1.700 G	1.00 M	1.698600 G	-49.07	-36.07
1.765 G	3.000 G	1.00 M	1.771175 G	-35.23	-22.23
3.000 G	9.000 G	1.00 M	3.468000 G	-43.37	-30.37
9.000 G	13.000 G	1.00 M	10.672000 G	-42.12	-29.12
13.000 G	18.000 G	1.00 M	17.665000 G	-40.71	-27.71

Date: 7.JAN.2015 23:08:32

Highest Channel / 16QAM

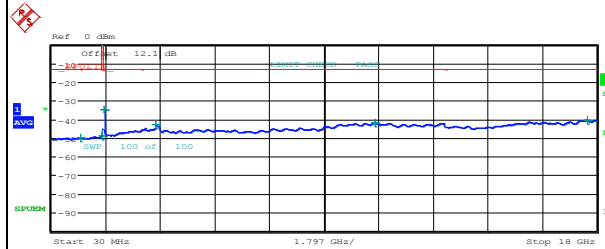

Start [Hz]	Stop [Hz]	RBW [Hz]	Freq [Hz]	PwrAbs [dBm]	Δ Limit [dB]
30.000 M	1.000 G	1.00 M	967.020000 M	-50.13	-37.13
1.000 G	1.700 G	1.00 M	1.699300 G	-48.92	-35.92
1.765 G	3.000 G	1.00 M	1.771175 G	-34.82	-21.82
3.000 G	9.000 G	1.00 M	3.468000 G	-43.09	-30.09
9.000 G	13.000 G	1.00 M	10.672000 G	-42.12	-29.12
13.000 G	18.000 G	1.00 M	17.670000 G	-40.63	-27.63

Date: 7.JAN.2015 23:09:43



LTE Band 13 / 5MHz

Lowest Channel / QPSK

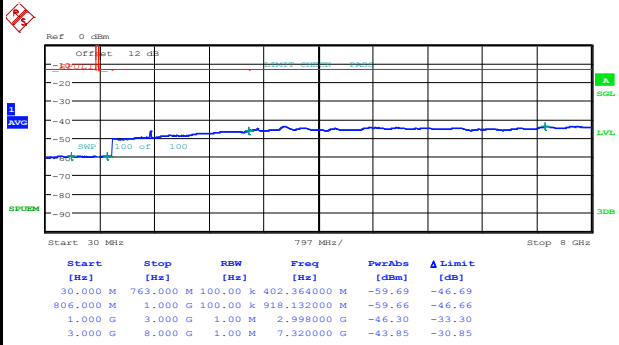

Date: 10.JAN.2015 00:15:11

Lowest Channel / 16QAM

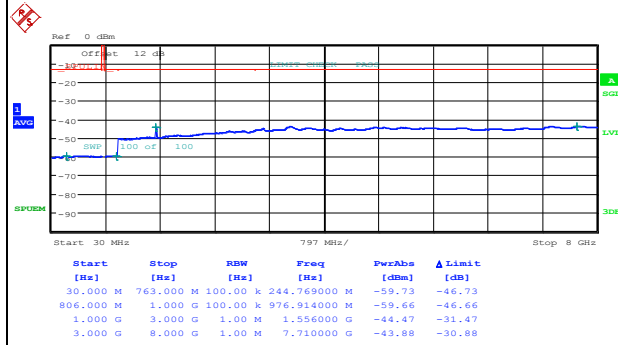

Date: 10.JAN.2015 00:22:03

Middle Channel / QPSK

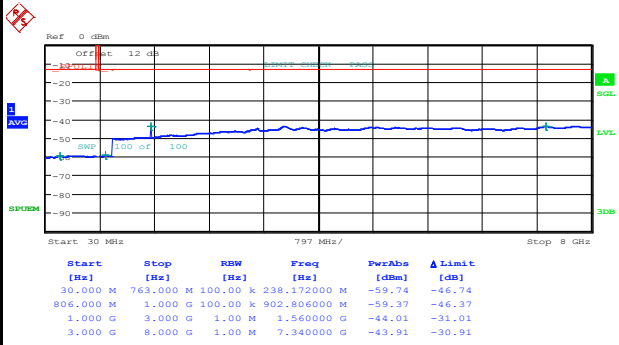

Date: 10.JAN.2015 00:24:25

Middle Channel / 16QAM

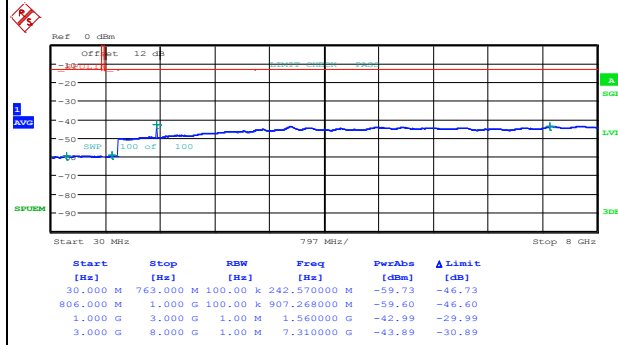

Date: 10.JAN.2015 00:23:14



LTE Band 13 / 5MHz

Highest Channel / QPSK

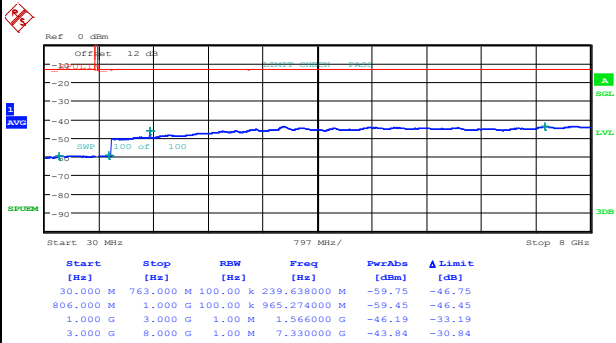

Date: 10.JAN.2015 00:25:36

Highest Channel / 16QAM

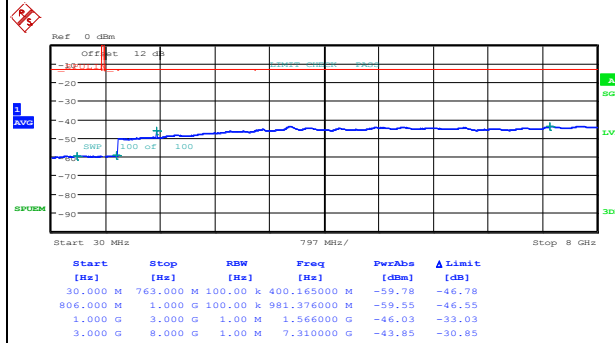

Date: 10.JAN.2015 00:26:47

LTE Band 13 / 10MHz

Middle Channel / QPSK

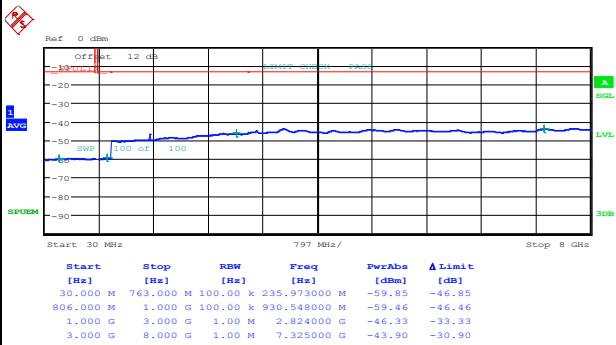

Date: 10.JAN.2015 00:34:10

Middle Channel / 16QAM

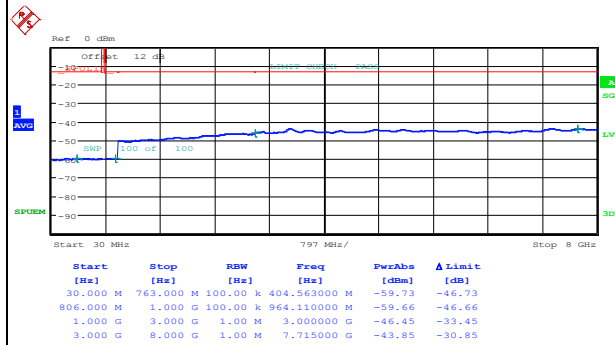

Date: 10.JAN.2015 00:28:03



Frequency Stability

Test Conditions		LTE Band 4 (QPSK) / Middle Channel	Limit
Temperature (°C)	Voltage (Volt)	BW 10MHz	Note 2.
		Deviation (ppm)	Result
50	Normal Voltage	0.0036	PASS
40	Normal Voltage	0.0021	
30	Normal Voltage	0.0024	
20(Ref.)	Normal Voltage	0.0000	
10	Normal Voltage	0.0060	
0	Normal Voltage	0.0072	
-10	Normal Voltage	0.0003	
-20	Normal Voltage	0.0017	
-30	Normal Voltage	0.0003	
20	Maximum Voltage	0.0069	
20	Normal Voltage	0.0033	
20	Battery End Point	0.0025	

Note:

1. Normal Voltage = 3.8V. ; Battery End Point (BEP) = 3.3 V. ; Maximum Voltage = 4.4 V
2. Note: The frequency fundamental emissions stay within the authorized frequency block based on the frequency deviation measured is small.





Test Conditions		LTE Band 13 (QPSK) / Middle Channel	Limit
Temperature (°C)	Voltage (Volt)	BW 10MHz	Note 2.
		Deviation (ppm)	Result
50	Normal Voltage	0.0063	PASS
40	Normal Voltage	0.0079	
30	Normal Voltage	0.0045	
20(Ref.)	Normal Voltage	0.0000	
10	Normal Voltage	0.0045	
0	Normal Voltage	0.0004	
-10	Normal Voltage	0.0069	
-20	Normal Voltage	0.0056	
-30	Normal Voltage	0.0052	
20	Maximum Voltage	0.0081	
20	Normal Voltage	0.0093	
20	Battery End Point	0.0019	

**Note:**

1. Normal Voltage = 3.8V. ; Battery End Point (BEP) = 3.3 V. ; Maximum Voltage =4.4 V
2. Note: The frequency fundamental emissions stay within the authorized frequency block based on the frequency deviation measured is small.



## Appendix B. Test Results of Radiated Test

### Radiated Spurious Emission

LTE Band 4 / 5MHz / QPSK / RB Size 1 Offset 0									
Channel	Frequency ( MHz )	EIRP ( dBm )	Limit ( dBm )	Over Limit ( dB )	SPA Reading (dBm)	S.G. Power ( dBm )	TX Cable loss ( dB )	TX Antenna Gain (dBi)	Polarization (H/V)
Lowest	3424	-48.59	-13	-35.59	-65.35	-54.68	1.58	7.67	H
	5136	-49.06	-13	-36.06	-71.89	-56.34	2.42	9.70	H
	6844	-45.44	-13	-32.44	-72.7	-53.41	2.64	10.61	H
	3424	-44.64	-13	-31.64	-61.21	-50.73	1.58	7.67	V
	5136	-44.20	-13	-31.20	-66.68	-51.48	2.42	9.70	V
	6844	-40.32	-13	-27.32	-66.78	-48.29	2.64	10.61	V
Middle	3464	-50.45	-13	-37.45	-67.06	-56.7	1.59	7.84	H
	5196	-45.35	-13	-32.35	-68.57	-52.6	2.45	9.70	H
	6924	-49.59	-13	-36.59	-76.6	-57.68	2.62	10.71	H
	3464	-47.59	-13	-34.59	-64.35	-53.84	1.59	7.84	V
	5196	-40.34	-13	-27.34	-62.51	-47.59	2.45	9.70	V
	6924	-45.38	-13	-32.38	-72.44	-53.47	2.62	10.71	V
Highest	3504	-46.49	-13	-33.49	-64.04	-52.89	1.61	8.00	H
	5256	-45.16	-13	-32.16	-67.78	-52.38	2.48	9.70	H
	7004	-48.26	-13	-35.26	-75.68	-56.48	2.59	10.81	H
	3504	-43.18	-13	-30.18	-60.8	-49.58	1.61	8.00	V
	5256	-42.30	-13	-29.30	-64.92	-49.52	2.48	9.70	V
	7004	-43.38	-13	-30.38	-70.79	-51.6	2.59	10.81	V

Remark: Spurious emissions within 30-1000MHz were found more than 20dB below limit line.



LTE Band 4 / 10MHz / QPSK / RB Size 1 Offset 0									
Channel	Frequency ( MHz )	EIRP ( dBm )	Limit ( dBm )	Over Limit ( dB )	SPA Reading (dBm)	S.G. Power ( dBm )	TX Cable loss ( dB )	TX Antenna Gain (dBi)	Polarization (H/V)
Lowest	3424	-48.45	-13	-35.45	-65.17	-54.54	1.58	7.67	H
	5136	-48.20	-13	-35.20	-71.16	-55.48	2.42	9.70	H
	6848	-47.40	-13	-34.40	-74.01	-55.38	2.64	10.62	H
	3424	-43.49	-13	-30.49	-60.04	-49.58	1.58	7.67	V
	5136	-45.50	-13	-32.50	-67.24	-52.78	2.42	9.70	V
	6848	-43.44	-13	-30.44	-69.94	-51.42	2.64	10.62	V
Middle	3460	-44.17	-13	-31.17	-61.79	-50.4	1.59	7.82	H
	5188	-42.53	-13	-29.53	-65.11	-49.78	2.45	9.70	H
	5916	-48.93	-13	-35.93	-76.36	-55.93	2.86	9.87	H
	3460	-39.07	-13	-26.07	-56.93	-45.3	1.59	7.82	V
	5188	-38.43	-13	-25.43	-60.5	-45.68	2.45	9.70	V
	5916	-46.78	-13	-33.78	-73.76	-53.78	2.86	9.87	V
Highest	3496	-47.29	-13	-34.29	-64.56	-53.67	1.60	7.98	H
	5240	-48.66	-13	-35.66	-71.18	-55.88	2.48	9.70	H
	6988	-47.61	-13	-34.61	-75.3	-55.8	2.59	10.79	H
	3496	-43.82	-13	-30.82	-60.88	-50.2	1.60	7.98	V
	5240	-42.96	-13	-29.96	-65.62	-50.18	2.48	9.70	V
	6988	-43.21	-13	-30.21	-70.61	-51.4	2.59	10.79	V

Remark: Spurious emissions within 30-1000MHz were found more than 20dB below limit line.

LTE Band 4 / 15MHz / QPSK / RB Size 1 Offset 0									
Channel	Frequency ( MHz )	EIRP ( dBm )	Limit ( dBm )	Over Limit ( dB )	SPA Reading (dBm)	S.G. Power ( dBm )	TX Cable loss ( dB )	TX Antenna Gain (dBi)	Polarization (H/V)
Lowest	3424	-50.21	-13	-37.21	-67.05	-56.3	1.58	7.67	H
	5136	-49.20	-13	-36.20	-71.94	-56.48	2.42	9.70	H
	6848	-48.33	-13	-35.33	-75.14	-56.31	2.64	10.62	H
	3424	-46.31	-13	-33.31	-62.76	-52.4	1.58	7.67	V
	5136	-48.39	-13	-35.39	-70.17	-55.67	2.42	9.70	V
	6848	-44.76	-13	-31.76	-71.33	-52.74	2.64	10.62	V
Middle	3456	-47.46	-13	-34.46	-64.24	-53.68	1.59	7.81	H
	5180	-38.34	-13	-25.34	-61.32	-45.6	2.44	9.70	H
	6908	-48.42	-13	-35.42	-76.01	-56.49	2.62	10.69	H
	3456	-44.58	-13	-31.58	-61.63	-50.8	1.59	7.81	V
	5180	-43.64	-13	-30.64	-65.83	-50.9	2.44	9.70	V
	6908	-45.62	-13	-32.62	-72.75	-53.69	2.62	10.69	V
Highest	3484	-50.36	-13	-37.36	-67.57	-56.69	1.60	7.93	H
	5228	-50.26	-13	-37.26	-73.45	-57.49	2.47	9.70	H
	6968	-49.31	-13	-36.31	-76.88	-57.47	2.60	10.76	H
	3484	-46.15	-13	-33.15	-63.36	-52.48	1.60	7.93	V
	5228	-47.38	-13	-34.38	-70.27	-54.61	2.47	9.70	V
	6968	-47.26	-13	-34.26	-74.38	-55.42	2.60	10.76	V

Remark: Spurious emissions within 30-1000MHz were found more than 20dB below limit line.



LTE Band 4 / 20MHz / QPSK / RB Size 1 Offset 0									
Channel	Frequency ( MHz )	EIRP ( dBm )	Limit ( dBm )	Over Limit ( dB )	SPA Reading (dBm)	S.G. Power ( dBm )	TX Cable loss ( dB )	TX Antenna Gain (dBi)	Polarization (H/V)
Lowest	3428	-50.48	-13	-37.48	-67.15	-56.58	1.58	7.68	H
	5136	-48.59	-13	-35.59	-71.75	-55.87	2.42	9.70	H
	6848	-47.34	-13	-34.34	-74.59	-55.32	2.64	10.62	H
	3428	-44.58	-13	-31.58	-61.01	-50.68	1.58	7.68	V
	5136	-46.21	-13	-33.21	-68.08	-53.49	2.42	9.70	V
	6848	-44.88	-13	-31.88	-71.51	-52.86	2.64	10.62	V
Middle	3452	-48.17	-13	-35.17	-65.26	-54.37	1.59	7.79	H
	5176	-47.41	-13	-34.41	-70.08	-54.67	2.44	9.70	H
	6900	-49.49	-13	-36.49	-76.54	-57.55	2.62	10.68	H
	3452	-42.55	-13	-29.55	-59.1	-48.75	1.59	7.79	V
	5176	-43.11	-13	-30.11	-65.37	-50.37	2.44	9.70	V
	6900	-47.39	-13	-34.39	-73.93	-55.45	2.62	10.68	V
Highest	3476	-51.17	-13	-38.17	-68.34	-57.47	1.60	7.89	H
	5212	-49.16	-13	-36.16	-72.01	-56.4	2.46	9.70	H
	6948	-49.48	-13	-36.48	-77.03	-57.61	2.61	10.74	H
	3476	-44.34	-13	-31.34	-62.13	-50.64	1.60	7.89	V
	5212	-44.24	-13	-31.24	-66.77	-51.48	2.46	9.70	V
	6948	-48.19	-13	-35.19	-75.38	-56.32	2.61	10.74	V

Remark: Spurious emissions within 30-1000MHz were found more than 20dB below limit line.



LTE Band 13 / 5MHz / QPSK / RB Size 1 Offset 0									
Channel	Frequency ( MHz )	ERP ( dBm )	Limit ( dBm )	Over Limit ( dB )	SPA Reading (dBm)	S.G. Power ( dBm )	TX Cable loss ( dB )	TX Antenna Gain (dBi)	Polarization (H/V)
Lowest	1552	-51.60	-13	-38.60	-61.71	-53.67	0.94	5.15	H
	2336	-55.63	-13	-42.63	-68.66	-57.15	1.24	4.91	H
	3112	-58.34	-13	-45.34	-75.32	-61.00	1.48	6.29	H
	3888	-53.51	-13	-40.51	-73.53	-58.10	1.73	8.47	H
	4664	-52.16	-13	-39.16	-74.64	-56.89	2.14	9.03	H
	1552	-51.51	-13	-38.51	-59.38	-53.58	0.94	5.15	V
	2336	-50.22	-13	-37.22	-64.93	-51.74	1.24	4.91	V
	3112	-56.23	-13	-43.23	-71.83	-58.89	1.48	6.29	V
	3888	-54.21	-13	-41.21	-73.51	-58.80	1.73	8.47	V
	4664	-50.47	-13	-37.47	-71.54	-55.20	2.14	9.03	V
Middle	1560	-49.44	-42.15	-7.29	-60.05	-51.48	0.94	5.13	H
	2336	-58.29	-13	-45.29	-71.75	-59.81	1.24	4.91	H
	3120	-57.31	-13	-44.31	-74.25	-60.00	1.49	6.33	H
	3896	-49.55	-13	-36.55	-69.58	-54.15	1.73	8.48	H
	1560	-51.45	-42.15	-9.30	-59.55	-53.49	0.94	5.13	V
	2336	-53.46	-13	-40.46	-67.90	-54.98	1.24	4.91	V
	3120	-55.30	-13	-42.30	-71.63	-57.99	1.49	6.33	V
	3896	-51.09	-13	-38.09	-70.34	-55.69	1.73	8.48	V
Highest	1568	-53.26	-42.15	-11.11	-63.24	-55.28	0.94	5.11	H
	2344	-58.94	-13	-45.94	-72.22	-60.48	1.24	4.93	H
	3128	-55.75	-13	-42.75	-72.99	-58.48	1.49	6.36	H
	3912	-46.69	-13	-33.69	-67.34	-51.30	1.73	8.49	H
	4696	-53.22	-13	-40.22	-75.59	-58.00	2.16	9.09	H
	1568	-54.46	-42.15	-12.31	-62.88	-56.48	0.94	5.11	V
	2344	-54.76	-13	-41.76	-69.68	-56.30	1.24	4.93	V
	3128	-53.79	-13	-40.79	-69.77	-56.52	1.49	6.36	V
	3912	-44.18	-13	-31.18	-64.27	-48.79	1.73	8.49	V
	4696	-51.36	-13	-38.36	-72.17	-56.14	2.16	9.09	V

Remark: Spurious emissions within 30-1000MHz were found more than 20dB below limit line.



LTE Band 13 / 10MHz / QPSK / RB Size 1 Offset 0									
Channel	Frequency ( MHz )	ERP ( dBm )	Limit ( dBm )	Over Limit ( dB )	SPA Reading (dBm)	S.G. Power ( dBm )	TX Cable loss ( dB )	TX Antenna Gain (dBi)	Polarization (H/V)
Middle	1560	-52.27	-42.15	-10.12	-62.24	-54.31	0.94	5.13	H
	2336	-57.26	-13	-44.26	-70.86	-58.78	1.24	4.91	H
	3112	-57.82	-13	-44.82	-75.01	-60.48	1.48	6.29	H
	3888	-52.17	-13	-39.17	-72.74	-56.76	1.73	8.47	H
	4664	-51.14	-13	-38.14	-73.88	-55.87	2.14	9.03	H
	1560	-50.27	-42.15	-8.12	-58.32	-52.31	0.94	5.13	V
	2336	-52.27	-13	-39.27	-67.44	-53.79	1.24	4.91	V
	3112	-56.92	-13	-43.92	-72.76	-59.58	1.48	6.29	V
	3888	-53.27	-13	-40.27	-72.83	-57.86	1.73	8.47	V
4664	-50.39	-13	-37.39	-71.28	-55.12	2.14	9.03	V	

Remark: Spurious emissions within 30-1000MHz were found more than 20dB below limit line.