

DATA SHEET

WIRELESS COMPONENTS

Ceramic Chip Antenna

ANT3216LL11R2400A

2.4 – 2.5GHz

3216 Series



Manufacturer: Yageo
Company Address: 3F, 233-1, Baoqiao Rd.
Xindian Dist., New Taipei City 23145 Taiwan

YAGEO
Phycomp

Product Specification – March 27, 2013 V.0



FEATURES

- Compact size
- Omni-directional radiation
- Tape & reel automatic mounting
- Reflow process compatible
- RoHS compliant

APPLICATIONS

- 2.4 GHz WiFi device
- Bluetooth gadget
- Zigbee device
- ISM band equipment

ORDERING INFORMATION

All part numbers are identified by the series, packing type, material, size, antenna type, working frequency and packing quantity.

PART NUMBER

ANT 3216 L L11 R 2400A
 (1) (2) (3) (4) (5) (6)

(1) PRODUCT

ANT = Antenna

(2) SIZE

3216 = 3.2 × 1.6 mm

(3) ANTENNA TYPE

L,F,A = Chip Antenna

(4) SERIAL NO.

L11

(5) PACKING TYPE

R = Tape and Reel

(6) WORKING FREQUENCY

2400 = 2.4GHz

PHYCOMP CTC

CAN431171211245K

I2NC

431171211245

SPECIFICATION

Table 1

DESCRIPTION	VALUE
Centre Frequency	2.45 GHz
Bandwidth	230 MHz (Typ.)
Return Loss	6.5 dB Min
Polarization	Linear
Azimuth Beamwidth	Omni-directional
Peak Gain	3.68 dBi (Typ.)
Impedance	50 Ω
Operating Temperature	- 40 °C ~ 105 °C
Maximum Power	1 W
Termination	Ag (Environmentally-Friendly Leadless)
Resistance to Soldering Heats	260°C , 10sec.

NOTE

I. The specification is defined on Yageo evaluation board

DIMENSIONS

Table 2 Machinical Dimension

	DIMENSION
L (mm)	3.2 ±0.10
W (mm)	1.6 ±0.10
T (mm)	1.2 ±0.10

OUTLINES

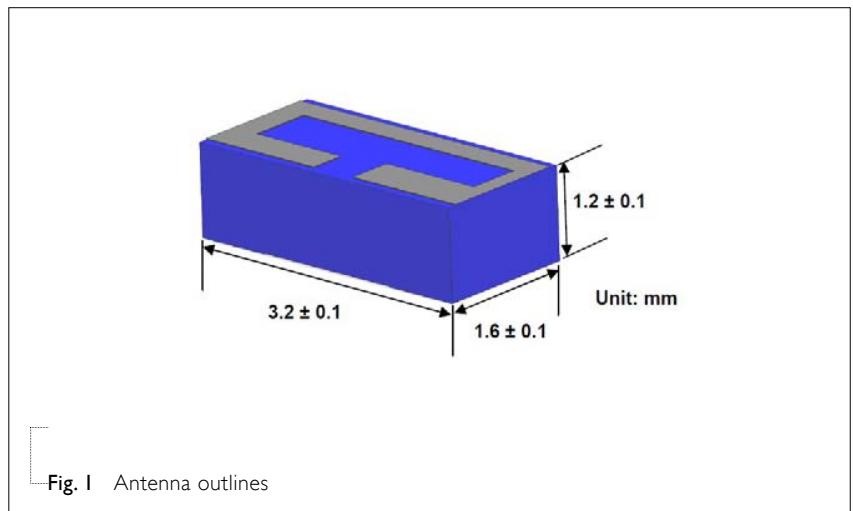

REFERENCE DESIGN OF EVALUATION BOARD

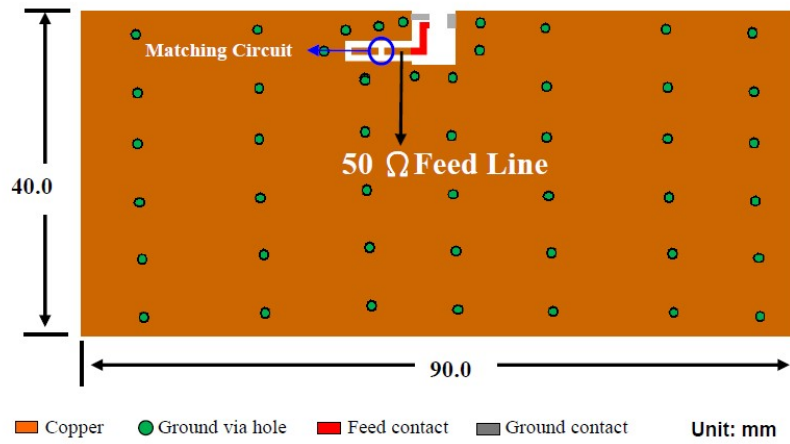

Fig. 2 Outlook and dimension of evaluation board

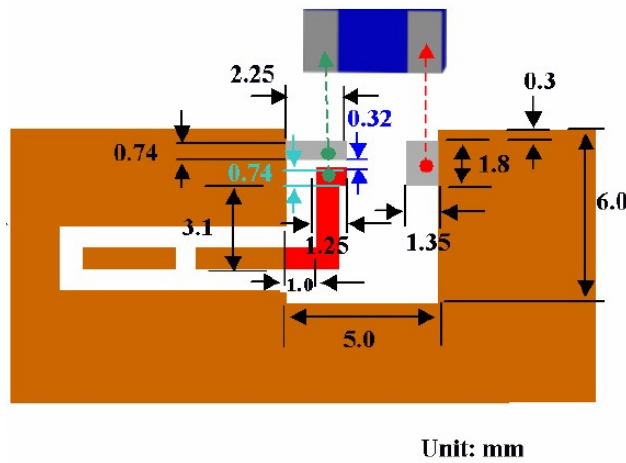

Fig. 3 Details of soldering Pad

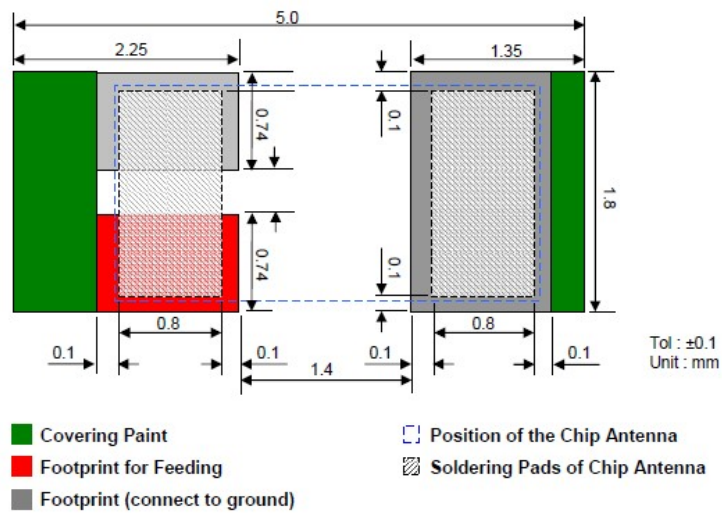
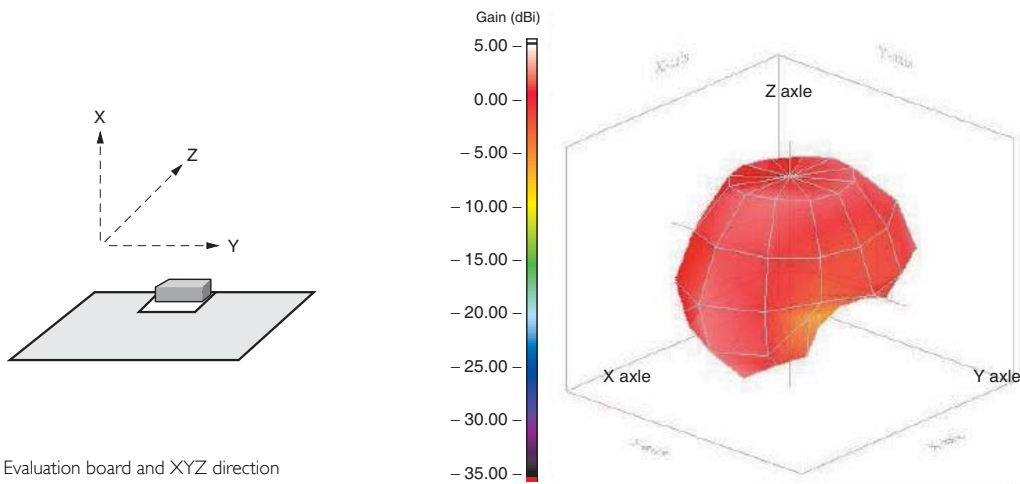

Fig. 4 Soldering Pads Dimension and Footprint

ELECTRICAL PERFORMANCES



Fig. 5 Return loss



YNH00161

Frequency= 2.45 GHz
 Max gain = 3.68 dBi, at (120,180)
 MEG (mean effective gain)= -0.47 dBi
 Directivity (dB) = 4.29
 Efficiency = -0.61 dB, 86.89 %

Fig. 6 Radiation pattern

REVISION HISTORY

REVISION	DATE	CHANGE NOTIFICATION	DESCRIPTION
Version 0	Mar. 27, 2013	-	- New data sheet for Ceramic Chip Antenna, 2.4-2.5GHz application, 3216 series