

FCC Test Report (BT-EDR)

Report No.: RF160819E01G-1

FCC ID: COF-WMBNBM26A

Test Model: WM-BN-BM-26_A_FF4

Series Model: Refer to section 3.1 for more details

Received Date: Aug. 26, 2019

Test Date: Aug. 31 to Sep. 11, 2019

Issued Date: Sep. 23, 2019

Applicant: UNIVERSAL GLOBAL SCIENTIFIC INDUSTRIAL CO., LTD.

Address: 141, Lane 351, Sec. 1, Taiping Road., Tsautuen, Nantou 54261, Taiwan

Issued By: Bureau Veritas Consumer Products Services (H.K.) Ltd., Taoyuan Branch
Hsin Chu Laboratory

Lab Address: E-2, No.1, Li Hsin 1st Road, Hsinchu Science Park, Hsinchu City 300,
Taiwan.

Test Location : E-2, No.1, Li Hsin 1st Road, Hsinchu Science Park, Hsinchu City 300,
Taiwan.

**FCC Registration /
Designation Number:** 723255 / TW2022



This report is for your exclusive use. Any copying or replication of this report to or for any other person or entity, or use of our name or trademark, is permitted only with our prior written permission. This report sets forth our findings solely with respect to the test samples identified herein. The results set forth in this report are not indicative or representative of the quality or characteristics of the lot from which a test sample was taken or any similar or identical product unless specifically and expressly noted. Our report includes all of the tests requested by you and the results thereof based upon the information that you provided to us. You have 60 days from date of issuance of this report to notify us of any material error or omission caused by our negligence, provided, however, that such notice shall be in writing and shall specifically address the issue you wish to raise. A failure to raise such issue within the prescribed time shall constitute your unqualified acceptance of the completeness of this report, the tests conducted and the correctness of the report contents. Unless specific mention, the uncertainty of measurement has been explicitly taken into account to declare the compliance or non-compliance to the specification. The report must not be used by the client to claim product certification, approval, or endorsement by TAF or any government agencies.

Table of Contents

Release Control Record	3
1 Certificate of Conformity	4
2 Summary of Test Results	5
2.1 Measurement Uncertainty	5
2.2 Modification Record	5
3 General Information	6
3.1 General Description of EUT (BT-EDR)	6
3.2 Description of Test Modes	8
3.2.1 Test Mode Applicability and Tested Channel Detail	9
3.3 Duty Cycle of Test Signal	10
3.4 Description of Support Units	11
3.4.1 Configuration of System under Test	11
3.5 General Description of Applied Standards	12
4 Test Types and Results	13
4.1 Radiated Emission and Bandedge Measurement	13
4.1.1 Limits of Radiated Emission and Bandedge Measurement	13
4.1.2 Test Instruments	14
4.1.3 Test Procedures	15
4.1.4 Deviation from Test Standard	16
4.1.5 Test Setup	16
4.1.6 EUT Operating Conditions	17
4.1.7 Test Results	18
4.2 Maximum Output Power	26
4.2.1 Limits of Maximum Output Power Measurement	26
4.2.2 Test Setup	26
4.2.3 Test Instruments	26
4.2.4 Test Procedure	26
4.2.5 Deviation from Test Standard	26
4.2.6 EUT Operating Condition	26
4.2.7 Test Results	27
5 Pictures of Test Arrangements	28
Appendix – Information of the Testing Laboratories	29

Release Control Record

Issue No.	Description	Date Issued
RF160819E01G-1	Original release.	Sep. 23, 2019

1 Certificate of Conformity

Product: 802.11b/g/n + BT Wireless LAN Module

Brand: USI

Test Model: WM-BN-BM-26_A_FF4

Series Model: Refer to section 3.1 for more details

Sample Status: ENGINEERING SAMPLE

Applicant: UNIVERSAL GLOBAL SCIENTIFIC INDUSTRIAL CO., LTD.

Test Date: Aug. 31 to Sep. 11, 2019

Standards: 47 CFR FCC Part 15, Subpart C (Section 15.247)
ANSI C63.10: 2013

The above equipment has been tested by **Bureau Veritas Consumer Products Services (H.K.) Ltd., Taoyuan Branch**, and found compliance with the requirement of the above standards. The test record, data evaluation & Equipment Under Test (EUT) configurations represented herein are true and accurate accounts of the measurements of the sample's EMC characteristics under the conditions specified in this report.

Prepared by : Wendy Wu, **Date:** Sep. 23, 2019
Wendy Wu / Specialist

Approved by : May Chen, **Date:** Sep. 23, 2019
May Chen / Manager

2 Summary of Test Results

47 CFR FCC Part 15, Subpart C (SECTION 15.247)

FCC Clause	Test Item	Result	Remarks
15.247(b)	Maximum Peak Output Power	PASS	Meet the requirement of limit.
15.205 & 209 & 15.247(d)	Radiated Emissions & Band Edge Measurement	PASS	Meet the requirement of limit. Minimum passing margin is -9.7dB at 31.18MHz.

NOTE:

1. Determining compliance based on the results of the compliance measurement, not taking into account measurement instrumentation uncertainty.
2. This report is supplementary report.

2.1 Measurement Uncertainty

Where relevant, the following measurement uncertainty levels have been estimated for tests performed on the EUT as specified in CISPR 16-4-2:

Measurement	Frequency	Expanded Uncertainty (k=2) (±)
Radiated Emissions up to 1 GHz	9kHz ~ 30MHz	3.0 dB
	30MHz ~ 1GHz	5.1 dB
Radiated Emissions above 1 GHz	1GHz ~ 6GHz	5.1 dB
	6GHz ~ 18GHz	5.0 dB
	18GHz ~ 40GHz	5.2 dB

2.2 Modification Record

There were no modifications required for compliance.

3 General Information

3.1 General Description of EUT (BT-EDR)

Product	802.11b/g/n + BT Wireless LAN Module
Brand	USI
Test Model	WM-BN-BM-26_A_FF4
Series Model	Refer to Note
Status of EUT	ENGINEERING SAMPLE
Power Supply Rating	3.6Vdc from host equipment
Modulation Type	GFSK, $\pi/4$ -DQPSK, 8DPSK
Modulation Technology	FHSS
Transfer Rate	Up to 3Mbps
Operating Frequency	2402MHz ~ 2480MHz
Number of Channel	79
Output Power	5.534mW
Antenna Type	Refer to Note
Antenna Connector	Refer to Note
Accessory Device	NA
Data Cable Supplied	NA

Note:

1. This report is prepared for FCC class II permissive change. The difference compared with the Report No.: RF160819E01D-1 as the following:

- ◆ Added the one new model name to change the RF matching and layout is same as following table:

Original		
Brand	Model	Diffenence
USI	WM-BN-BM-26_A	-
	WM-BN-BM-26_A_FF2	1. R30 capacitor 1.8pF change to 2.7pF belongs to part of antenna matching circuit. 2. C46 inductor remove
	WM-BN-BM-26_A_FF3	1. R30 resistor 0 Ohm change to 3.3nH inductor belongs to part of antenna matching circuit 2. Add 27pF capacitor on C172

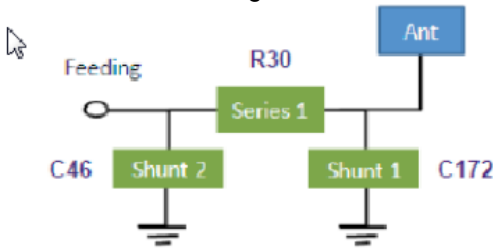
Newly																		
Brand	Model	Diffenence																
USI	WM-BN-BM-26_A_FF4	<p>1. C172 change to Open 2. R30's Capacitor change to 2.2pf 3. C46's Inductor change to 1.0nH</p>  <table border="1" style="margin-top: 10px;"> <thead> <tr> <th>Name</th> <th>Component</th> <th>Supplier</th> <th>Value</th> </tr> </thead> <tbody> <tr> <td>C172</td> <td>Shunt 1</td> <td>Open</td> <td></td> </tr> <tr> <td>R30</td> <td>Series 1</td> <td>Capacitor Yageo</td> <td>2.2pF</td> </tr> <tr> <td>C46</td> <td>Shunt 2</td> <td>Inductor Chillisin</td> <td>1.0nH</td> </tr> </tbody> </table>	Name	Component	Supplier	Value	C172	Shunt 1	Open		R30	Series 1	Capacitor Yageo	2.2pF	C46	Shunt 2	Inductor Chillisin	1.0nH
Name	Component	Supplier	Value															
C172	Shunt 1	Open																
R30	Series 1	Capacitor Yageo	2.2pF															
C46	Shunt 2	Inductor Chillisin	1.0nH															

From the above models, new model: WM-BN-BM-26_A_FF4 was selected as representative model for the test and its data was recorded in this report.

2. According to above conditions, only Conducted power and Radiated Emissions need to be performed. And all data were verified to meet the requirements.
3. There are WLAN, BT technology used for the EUT.
4. The antenna provided to the EUT, please refer to the following table:

Brand	Model	Antenna Net Gain(dBi)	Frequency range (GHz to GHz)	Antenna Type	Connector Type
YAGEO	ANT3216LL11R2400A	3.68	2.4~2.4835	Chip	NA

5. WLAN and BT technology cannot transmit at same time.
6. The above EUT information is declared by manufacturer and for more detailed features description, please refer to the manufacturer's specifications or user's manual.

3.2 Description of Test Modes

79 channels are provided for BT-EDR mode:

Channel	Freq. (MHz)	Channel	Freq. (MHz)	Channel	Freq. (MHz)	Channel	Freq. (MHz)
0	2402	20	2422	40	2442	60	2462
1	2403	21	2423	41	2443	61	2463
2	2404	22	2424	42	2444	62	2464
3	2405	23	2425	43	2445	63	2465
4	2406	24	2426	44	2446	64	2466
5	2407	25	2427	45	2447	65	2467
6	2408	26	2428	46	2448	66	2468
7	2409	27	2429	47	2449	67	2469
8	2410	28	2430	48	2450	68	2470
9	2411	29	2431	49	2451	69	2471
10	2412	30	2432	50	2452	70	2472
11	2413	31	2433	51	2453	71	2473
12	2414	32	2434	52	2454	72	2474
13	2415	33	2435	53	2455	73	2475
14	2416	34	2436	54	2456	74	2476
15	2417	35	2437	55	2457	75	2477
16	2418	36	2438	56	2458	76	2478
17	2419	37	2439	57	2459	77	2479
18	2420	38	2440	58	2460	78	2480
19	2421	39	2441	59	2461		

3.2.1 Test Mode Applicability and Tested Channel Detail

EUT CONFIGURE MODE	APPLICABLE TO			DESCRIPTION
	RE \geq 1G	RE<1G	APCM	
-	√	√	√	

Where **RE \geq 1G**: Radiated Emission above 1GHz **RE<1G**: Radiated Emission below 1GHz
APCM: Antenna Port Conducted Measurement

NOTE:

- In the original report, the EUT had been pre-tested on the positioned of each 3 axis. The worst case was found when positioned on **X-plane**.

Radiated Emission Test (Above 1GHz):

- Pre-Scan has been conducted to determine the worst-case mode from all possible combinations between available modulations, data rates and antenna ports (if EUT with antenna diversity architecture).
- Following channel(s) was (were) selected for the final test as listed below.

AVAILABLE CHANNEL	TESTED CHANNEL	MODULATION TECHNOLOGY	MODULATION TYPE	PACKET TYPE
0 to 78	0, 39, 78	FHSS	GFSK	DH5
0 to 78	0, 39, 78	FHSS	8DPSK	3DH5

Radiated Emission Test (Below 1GHz):

- Pre-Scan has been conducted to determine the worst-case mode from all possible combinations between available modulations, data rates and antenna ports (if EUT with antenna diversity architecture).
- Following channel(s) was (were) selected for the final test as listed below.

AVAILABLE CHANNEL	TESTED CHANNEL	MODULATION TECHNOLOGY	MODULATION TYPE	PACKET TYPE
0 to 78	78	FHSS	8DPSK	3DH5

Antenna Port Conducted Measurement:

- Pre-Scan has been conducted to determine the worst-case mode from all possible combinations between available modulations, data rates and antenna ports (if EUT with antenna diversity architecture).
- Following channel(s) was (were) selected for the final test as listed below.

AVAILABLE CHANNEL	TESTED CHANNEL	MODULATION TECHNOLOGY	MODULATION TYPE	PACKET TYPE
0 to 78	0, 39, 78	FHSS	GFSK	DH5
0 to 78	0, 39, 78	FHSS	8DPSK	3DH5

Test Condition:

APPLICABLE TO	ENVIRONMENTAL CONDITIONS	INPUT POWER (SYSTEM)	TESTED BY
RE \geq 1G	22deg. C, 67%RH	120Vac, 60Hz	Ryan Du
RE<1G	23deg. C, 67%RH	120Vac, 60Hz	Ryan Du
APCM	25deg. C, 60%RH	120Vac, 60Hz	Ryan Du

3.3 Duty Cycle of Test Signal

GFSK: Duty cycle = 2.884 ms/3.75 ms = 0.769, Duty factor = $10 * \log (1/ \text{Duty cycle}) = 1.14$

8DPSK: Duty cycle = 2.885 ms/3.75 ms = 0.769, Duty factor = $10 * \log (1/ \text{Duty cycle}) = 1.14$

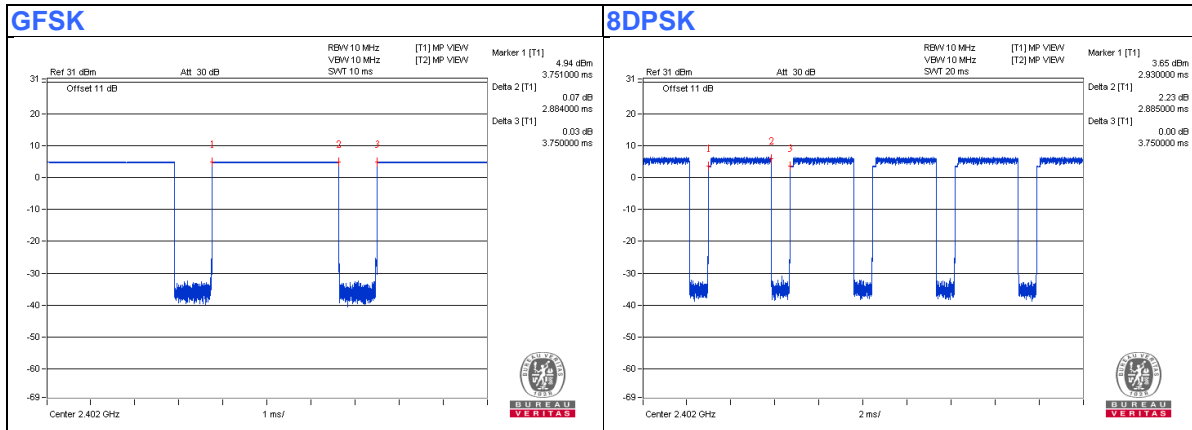

3.4 Description of Support Units

The EUT has been tested as an independent unit together with other necessary accessories or support units. The following support units or accessories were used to form a representative test configuration during the tests.

ID	Product	Brand	Model No.	Serial No.	FCC ID	Remarks
A.	Test Tool	NA	NA	NA	NA	Supplied by client
B.	DC Power Supply	Topward	6603D	795558	NA	Provided by Lab

Note:

1. All power cords of the above support units are non-shielded (1.8m).

ID	Descriptions	Qty.	Length (m)	Shielding (Yes/No)	Cores (Qty.)	Remarks
1.	DC Cable	1	1.8	No	0	Provided by Lab

3.4.1 Configuration of System under Test

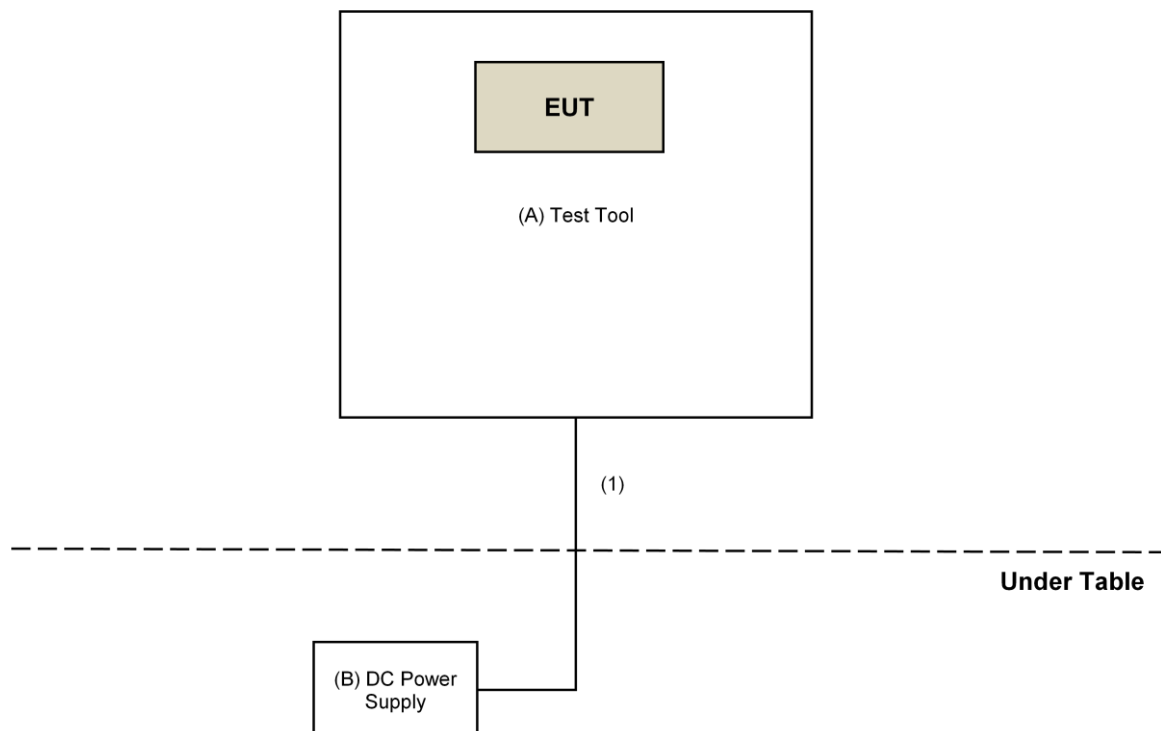

3.5 General Description of Applied Standards

The EUT is a RF Product. According to the specifications of the manufacturer, it must comply with the requirements of the following standards:

FCC Part 15, Subpart C (15.247)

KDB 558074 D01 15.247 Meas Guidance v05r02

ANSI C63.10-2013

All test items have been performed and recorded as per the above standards.

4 Test Types and Results

4.1 Radiated Emission and Bandedge Measurement

4.1.1 Limits of Radiated Emission and Bandedge Measurement

Radiated emissions which fall in the restricted bands must comply with the radiated emission limits specified as below table. Other emissions shall be at least 20dB below the highest level of the desired power:

Frequencies (MHz)	Field Strength (microvolts/meter)	Measurement Distance (meters)
0.009 ~ 0.490	2400/F(kHz)	300
0.490 ~ 1.705	24000/F(kHz)	30
1.705 ~ 30.0	30	30
30 ~ 88	100	3
88 ~ 216	150	3
216 ~ 960	200	3
Above 960	500	3

NOTE:

1. The lower limit shall apply at the transition frequencies.
2. Emission level (dBuV/m) = 20 log Emission level (uV/m).
3. For frequencies above 1000MHz, the field strength limits are based on average detector, however, the peak field strength of any emission shall not exceed the maximum permitted average limits, specified above by more than 20dB under any condition of modulation.

4.1.2 Test Instruments

DESCRIPTION & MANUFACTURER	MODEL NO.	SERIAL NO.	CALIBRATED DATE	CALIBRATED UNTIL
Test Receiver Agilent	N9038A	MY50010156	July 17, 2019	July 16, 2020
Pre-Amplifier EMCI	EMC001340	980142	May 30, 2019	May 29, 2020
Loop Antenna Electro-Metrics	EM-6879	264	Jan. 22, 2019	Jan. 21, 2020
RF Cable	NA	LOOPCAB-001	Jan. 14, 2019	Jan. 13, 2020
RF Cable	NA	LOOPCAB-002	Jan. 14, 2019	Jan. 13, 2020
Pre-Amplifier Mini-Circuits	ZFL-1000VH2B	AMP-ZFL-05	Apr. 30, 2019	Apr. 29, 2020
Trilog Broadband Antenna SCHWARZBECK	VULB 9168	9168-361	Nov. 22, 2018	Nov. 21, 2019
RF Cable	8D	966-3-1	Mar. 18, 2019	Mar. 17, 2020
RF Cable	8D	966-3-2	Mar. 18, 2019	Mar. 17, 2020
RF Cable	8D	966-3-3	Mar. 18, 2019	Mar. 17, 2020
Fixed attenuator Mini-Circuits	UNAT-5+	PAD-3m-3-01	Sep. 27, 2018	Sep. 26, 2019
Horn_Antenna SCHWARZBECK	BBHA9120-D	9120D-406	Nov. 25, 2018	Nov. 24, 2019
Pre-Amplifier EMCI	EMC12630SE	980384	Jan. 28, 2019	Jan. 27, 2020
RF Cable	EMC104-SM-SM-1200	160922	Jan. 28, 2019	Jan. 27, 2020
RF Cable	EMC104-SM-SM-2000	180601	June 10, 2019	June 09, 2020
RF Cable	EMC104-SM-SM-6000	180602	June 10, 2019	June 09, 2020
Spectrum Analyzer Keysight	N9030A	MY54490679	July 17, 2019	July 16, 2020
Pre-Amplifier EMCI	EMC184045SE	980387	Jan. 28, 2019	Jan. 27, 2020
Horn_Antenna SCHWARZBECK	BBHA 9170	BBHA9170519	Nov. 25, 2018	Nov. 24, 2019
RF Cable	EMC102-KM-KM-1200	160924	Jan. 28, 2019	Jan. 27, 2020
RF Cable	EMC102-KM-KM-1200	160925	Jan. 28, 2019	Jan. 27, 2020
Software	ADT_Radiated_V8.7.08	NA	NA	NA
Antenna Tower & Turn Table Max-Full	MF-7802	MF780208406	NA	NA
Boresight Antenna Fixture	FBA-01	FBA-SIP01	NA	NA

Note:

1. The calibration interval of the above test instruments is 12 months and the calibrations are traceable to NML/ROC and NIST/USA.
2. The test was performed in 966 Chamber No. 3.
3. Loop antenna was used for all emissions below 30 MHz.
4. Tested Date: Aug. 31 to Sep. 11, 2019

4.1.3 Test Procedures

For Radiated emission below 30MHz

- a. The EUT was placed on the top of a rotating table 0.8 meters above the ground at a 3 meter chamber room. The table was rotated 360 degrees to determine the position of the highest radiation.
- b. The EUT was set 3 meters away from the interference-receiving antenna, which was mounted on the top of a variable-height antenna tower.
- c. Parallel, perpendicular, and ground-parallel orientations of the antenna are set to make the measurement.
- d. For each suspected emission, the EUT was arranged to its worst case and the rotatable table was turned from 0 degrees to 360 degrees to find the maximum reading.
- e. The test-receiver system was set to Quasi-Peak Detect Function and Specified Bandwidth with Maximum Hold Mode.

NOTE:

1. The resolution bandwidth and video bandwidth of test receiver/spectrum analyzer is 9kHz at frequency below 30MHz.

For Radiated emission above 30MHz

- a. The EUT was placed on the top of a rotating table 0.8 meters (for 30MHz ~ 1GHz) / 1.5 meters (for above 1GHz) above the ground at 3 meter chamber room for test. The table was rotated 360 degrees to determine the position of the highest radiation.
- b. The EUT was set 3 meters away from the interference-receiving antenna, which was mounted on the top of a variable-height antenna tower.
- c. The height of antenna is varied from one meter to four meters above the ground to determine the maximum value of the field strength. Both horizontal and vertical polarizations of the antenna are set to make the measurement.
- d. For each suspected emission, the EUT was arranged to its worst case and then the antenna was tuned to heights from 1 meter to 4 meters and the rotatable table was turned from 0 degrees to 360 degrees to find the maximum reading.
- e. The test-receiver system was set to quasi-peak detect function and specified bandwidth with maximum hold mode when the test frequency is below 1 GHz.
- f. The test-receiver system was set to peak and average detect function and specified bandwidth with maximum hold mode when the test frequency is above 1 GHz. If the peak reading value also meets average limit, measurement with the average detector is unnecessary.

Note:

1. The resolution bandwidth and video bandwidth of test receiver/spectrum analyzer is 120kHz for Quasi-peak detection (QP) at frequency below 1GHz.
2. The resolution bandwidth of test receiver/spectrum analyzer is 1 MHz and the video bandwidth is 3 MHz for Peak detection (PK) at frequency above 1GHz.
3. The resolution bandwidth of test receiver/spectrum analyzer is 1MHz and the video bandwidth is $\geq 1/T$ (Duty cycle < 98%) or 10Hz (Duty cycle $\geq 98\%$) for Average detection (AV) at frequency above 1GHz.
4. All modes of operation were investigated and the worst-case emissions are reported.

4.1.4 Deviation from Test Standard

No deviation.

4.1.5 Test Setup

For Radiated emission below 30MHz

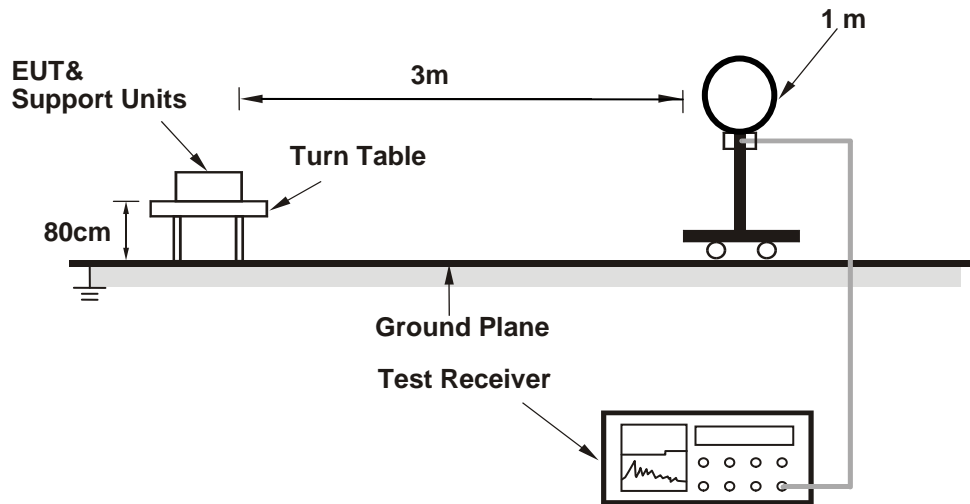

For Radiated emission 30MHz to 1GHz

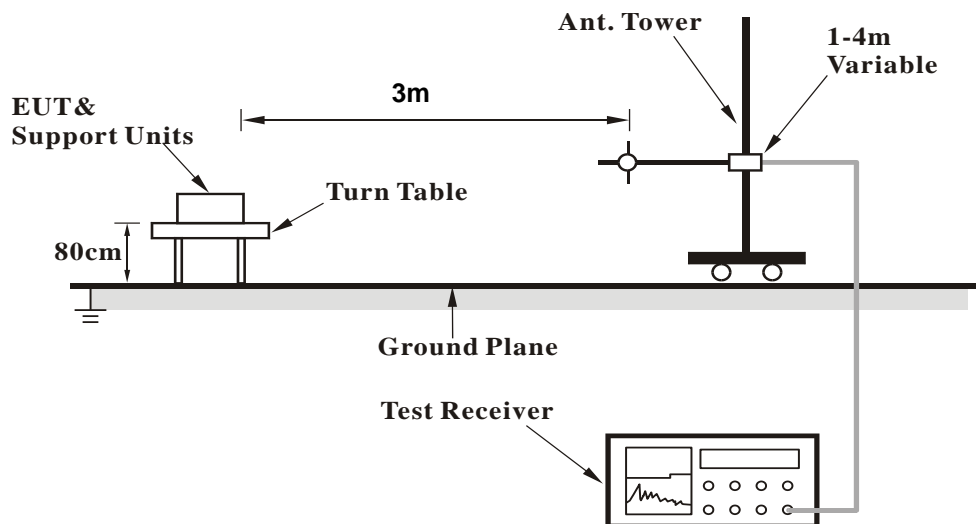

For Radiated emission above 1GHz

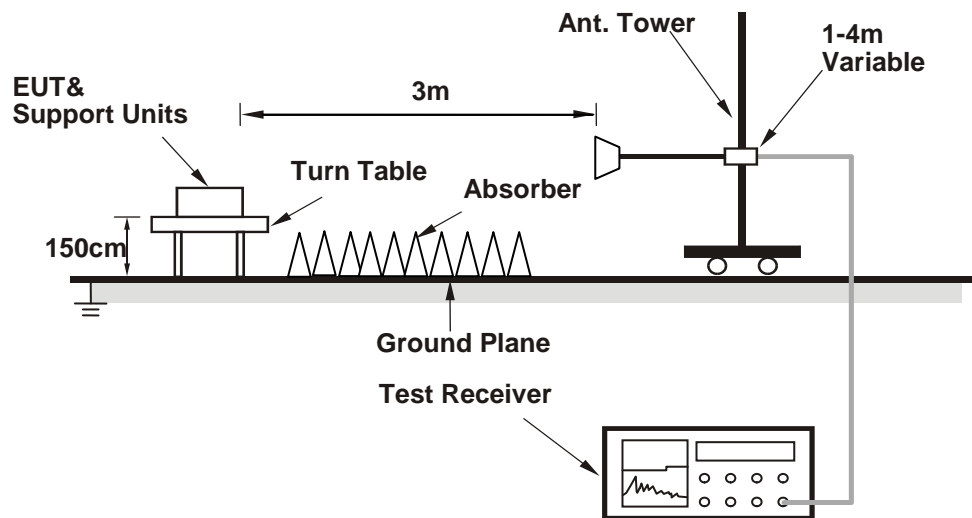

For the actual test configuration, please refer to the attached file (Test Setup Photo).

4.1.6 EUT Operating Conditions

- a. Placed the EUT on the testing table.
- b. Controlling software (sh use Test scripts.sh) has been activated to set the EUT under transmission condition continuously at specific channel frequency.

4.1.7 Test Results

Above 1GHz Data:

BT_GFSK

CHANNEL	TX Channel 0	DETECTOR FUNCTION	Peak (PK)
FREQUENCY RANGE	1GHz ~ 25GHz		Average (AV)

ANTENNA POLARITY & TEST DISTANCE: HORIZONTAL AT 3 M								
NO.	FREQ. (MHz)	EMISSION LEVEL (dBuV/m)	LIMIT (dBuV/m)	MARGIN (dB)	ANTENNA HEIGHT (m)	TABLE ANGLE (Degree)	RAW VALUE (dBuV)	CORRECTION FACTOR (dB/m)
1	2390.00	53.5 PK	74.0	-20.5	1.22 H	9	55.5	-2.0
2	2390.00	38.6 AV	54.0	-15.4	1.22 H	9	40.6	-2.0
3	*2402.00	100.8 PK			1.22 H	9	102.8	-2.0
4	*2402.00	100.2 AV			1.22 H	9	102.2	-2.0
5	4804.00	40.7 PK	74.0	-33.3	1.71 H	103	38.4	2.3
6	4804.00	28.6 AV	54.0	-25.4	1.71 H	103	26.3	2.3
ANTENNA POLARITY & TEST DISTANCE: VERTICAL AT 3 M								
NO.	FREQ. (MHz)	EMISSION LEVEL (dBuV/m)	LIMIT (dBuV/m)	MARGIN (dB)	ANTENNA HEIGHT (m)	TABLE ANGLE (Degree)	RAW VALUE (dBuV)	CORRECTION FACTOR (dB/m)
1	2390.00	54.3 PK	74.0	-19.7	2.91 V	317	56.3	-2.0
2	2390.00	39.1 AV	54.0	-14.9	2.91 V	317	41.1	-2.0
3	*2402.00	87.2 PK			2.91 V	317	89.2	-2.0
4	*2402.00	86.7 AV			2.91 V	317	88.7	-2.0
5	4804.00	40.0 PK	74.0	-34.0	3.31 V	59	37.7	2.3
6	4804.00	27.9 AV	54.0	-26.1	3.31 V	59	25.6	2.3

REMARKS:

1. Emission Level(dBuV/m) = Raw Value(dBuV) + Correction Factor(dB/m)
2. Correction Factor(dB/m) = Antenna Factor(dB/m) + Cable Factor(dB) – Pre-Amplifier Factor(dB)
3. Margin value = Emission Level – Limit value
4. The other emission levels were very low against the limit.
5. " * ": Fundamental frequency.

CHANNEL	TX Channel 39	DETECTOR FUNCTION	Peak (PK)
FREQUENCY RANGE	1GHz ~ 25GHz		Average (AV)

ANTENNA POLARITY & TEST DISTANCE: HORIZONTAL AT 3 M								
NO.	FREQ. (MHz)	EMISSION LEVEL (dBuV/m)	LIMIT (dBuV/m)	MARGIN (dB)	ANTENNA HEIGHT (m)	TABLE ANGLE (Degree)	RAW VALUE (dBuV)	CORRECTION FACTOR (dB/m)
1	*2441.00	101.1 PK			1.24 H	6	103.2	-2.1
2	*2441.00	100.5 AV			1.24 H	6	102.6	-2.1
3	4882.00	40.1 PK	74.0	-33.9	1.70 H	102	37.8	2.3
4	4882.00	28.1 AV	54.0	-25.9	1.70 H	102	25.8	2.3
5	7323.00	46.0 PK	74.0	-28.0	1.47 H	138	37.8	8.2
6	7323.00	34.8 AV	54.0	-19.2	1.47 H	138	26.6	8.2

ANTENNA POLARITY & TEST DISTANCE: VERTICAL AT 3 M								
NO.	FREQ. (MHz)	EMISSION LEVEL (dBuV/m)	LIMIT (dBuV/m)	MARGIN (dB)	ANTENNA HEIGHT (m)	TABLE ANGLE (Degree)	RAW VALUE (dBuV)	CORRECTION FACTOR (dB/m)
1	*2441.00	87.5 PK			2.97 V	319	89.6	-2.1
2	*2441.00	87.0 AV			2.97 V	319	89.1	-2.1
3	4882.00	40.4 PK	74.0	-33.6	3.32 V	49	38.1	2.3
4	4882.00	28.4 AV	54.0	-25.6	3.32 V	49	26.1	2.3
5	7323.00	44.9 PK	74.0	-29.1	2.39 V	33	36.7	8.2
6	7323.00	33.8 AV	54.0	-20.2	2.39 V	33	25.6	8.2

REMARKS:

1. Emission Level(dBuV/m) = Raw Value(dBuV) + Correction Factor(dB/m)
2. Correction Factor(dB/m) = Antenna Factor(dB/m) + Cable Factor(dB) – Pre-Amplifier Factor(dB)
3. Margin value = Emission Level – Limit value
4. The other emission levels were very low against the limit.
5. " * ": Fundamental frequency.

CHANNEL	TX Channel 78	DETECTOR FUNCTION	Peak (PK)
FREQUENCY RANGE	1GHz ~ 25GHz		Average (AV)

ANTENNA POLARITY & TEST DISTANCE: HORIZONTAL AT 3 M								
NO.	FREQ. (MHz)	EMISSION LEVEL (dBuV/m)	LIMIT (dBuV/m)	MARGIN (dB)	ANTENNA HEIGHT (m)	TABLE ANGLE (Degree)	RAW VALUE (dBuV)	CORRECTION FACTOR (dB/m)
1	*2480.00	102.6 PK			1.15 H	31	104.8	-2.2
2	*2480.00	102.0 AV			1.15 H	31	104.2	-2.2
3	2483.50	54.3 PK	74.0	-19.7	1.15 H	31	56.5	-2.2
4	2483.50	39.5 AV	54.0	-14.5	1.15 H	31	41.7	-2.2
5	4960.00	40.5 PK	74.0	-33.5	1.77 H	101	38.0	2.5
6	4960.00	28.1 AV	54.0	-25.9	1.77 H	101	25.6	2.5
7	7440.00	46.2 PK	74.0	-27.8	1.40 H	121	37.8	8.4
8	7440.00	35.0 AV	54.0	-19.0	1.40 H	121	26.6	8.4

ANTENNA POLARITY & TEST DISTANCE: VERTICAL AT 3 M								
NO.	FREQ. (MHz)	EMISSION LEVEL (dBuV/m)	LIMIT (dBuV/m)	MARGIN (dB)	ANTENNA HEIGHT (m)	TABLE ANGLE (Degree)	RAW VALUE (dBuV)	CORRECTION FACTOR (dB/m)
1	*2480.00	88.9 PK			2.92 V	302	91.1	-2.2
2	*2480.00	88.4 AV			2.92 V	302	90.6	-2.2
3	2483.50	54.0 PK	74.0	-20.0	1.00 V	0	56.2	-2.2
4	2483.50	39.1 AV	54.0	-14.9	1.00 V	0	41.3	-2.2
5	4960.00	39.9 PK	74.0	-34.1	3.25 V	40	37.4	2.5
6	4960.00	27.8 AV	54.0	-26.2	3.25 V	40	25.3	2.5
7	7440.00	45.6 PK	74.0	-28.4	2.40 V	30	37.2	8.4
8	7440.00	34.4 AV	54.0	-19.6	2.40 V	30	26.0	8.4

REMARKS:

1. Emission Level(dBuV/m) = Raw Value(dBuV) + Correction Factor(dB/m)
2. Correction Factor(dB/m) = Antenna Factor(dB/m) + Cable Factor(dB) – Pre-Amplifier Factor(dB)
3. Margin value = Emission Level – Limit value
4. The other emission levels were very low against the limit.
5. " * ": Fundamental frequency.

BT_8DPSK

CHANNEL	TX Channel 0	DETECTOR FUNCTION	Peak (PK)
FREQUENCY RANGE	1GHz ~ 25GHz		Average (AV)

ANTENNA POLARITY & TEST DISTANCE: HORIZONTAL AT 3 M								
NO.	FREQ. (MHz)	EMISSION LEVEL (dBuV/m)	LIMIT (dBuV/m)	MARGIN (dB)	ANTENNA HEIGHT (m)	TABLE ANGLE (Degree)	RAW VALUE (dBuV)	CORRECTION FACTOR (dB/m)
1	2390.00	54.3 PK	74.0	-19.7	1.22 H	10	56.3	-2.0
2	2390.00	39.2 AV	54.0	-14.8	1.22 H	10	41.2	-2.0
3	*2402.00	103.6 PK			1.22 H	10	105.6	-2.0
4	*2402.00	103.0 AV			1.22 H	10	105.0	-2.0
5	4804.00	40.5 PK	74.0	-33.5	1.75 H	99	38.2	2.3
6	4804.00	28.4 AV	54.0	-25.6	1.75 H	99	26.1	2.3

ANTENNA POLARITY & TEST DISTANCE: VERTICAL AT 3 M								
NO.	FREQ. (MHz)	EMISSION LEVEL (dBuV/m)	LIMIT (dBuV/m)	MARGIN (dB)	ANTENNA HEIGHT (m)	TABLE ANGLE (Degree)	RAW VALUE (dBuV)	CORRECTION FACTOR (dB/m)
1	2390.00	54.0 PK	74.0	-20.0	2.93 V	303	56.0	-2.0
2	2390.00	39.0 AV	54.0	-15.0	2.93 V	303	41.0	-2.0
3	*2402.00	89.8 PK			2.93 V	303	91.8	-2.0
4	*2402.00	89.3 AV			2.93 V	303	91.3	-2.0
5	4804.00	40.6 PK	74.0	-33.4	3.26 V	39	38.3	2.3
6	4804.00	28.7 AV	54.0	-25.3	3.26 V	39	26.4	2.3

REMARKS:

1. Emission Level(dBuV/m) = Raw Value(dBuV) + Correction Factor(dB/m)
2. Correction Factor(dB/m) = Antenna Factor(dB/m) + Cable Factor(dB) – Pre-Amplifier Factor(dB)
3. Margin value = Emission Level – Limit value
4. The other emission levels were very low against the limit.
5. " * ": Fundamental frequency.

CHANNEL	TX Channel 39	DETECTOR FUNCTION	Peak (PK)
FREQUENCY RANGE	1GHz ~ 25GHz		Average (AV)

ANTENNA POLARITY & TEST DISTANCE: HORIZONTAL AT 3 M								
NO.	FREQ. (MHz)	EMISSION LEVEL (dBuV/m)	LIMIT (dBuV/m)	MARGIN (dB)	ANTENNA HEIGHT (m)	TABLE ANGLE (Degree)	RAW VALUE (dBuV)	CORRECTION FACTOR (dB/m)
1	*2441.00	104.3 PK			1.15 H	19	106.4	-2.1
2	*2441.00	103.7 AV			1.15 H	19	105.8	-2.1
3	4882.00	39.9 PK	74.0	-34.1	1.82 H	119	37.6	2.3
4	4882.00	28.1 AV	54.0	-25.9	1.82 H	119	25.8	2.3
5	7323.00	46.5 PK	74.0	-27.5	1.47 H	136	38.3	8.2
6	7323.00	35.3 AV	54.0	-18.7	1.47 H	136	27.1	8.2

ANTENNA POLARITY & TEST DISTANCE: VERTICAL AT 3 M								
NO.	FREQ. (MHz)	EMISSION LEVEL (dBuV/m)	LIMIT (dBuV/m)	MARGIN (dB)	ANTENNA HEIGHT (m)	TABLE ANGLE (Degree)	RAW VALUE (dBuV)	CORRECTION FACTOR (dB/m)
1	*2441.00	90.5 PK			2.87 V	300	92.6	-2.1
2	*2441.00	90.0 AV			2.87 V	300	92.1	-2.1
3	4882.00	40.5 PK	74.0	-33.5	3.31 V	47	38.2	2.3
4	4882.00	28.3 AV	54.0	-25.7	3.31 V	47	26.0	2.3
5	7323.00	45.5 PK	74.0	-28.5	2.39 V	30	37.3	8.2
6	7323.00	34.1 AV	54.0	-19.9	2.39 V	30	25.9	8.2

REMARKS:

1. Emission Level(dBuV/m) = Raw Value(dBuV) + Correction Factor(dB/m)
2. Correction Factor(dB/m) = Antenna Factor(dB/m) + Cable Factor(dB) – Pre-Amplifier Factor(dB)
3. Margin value = Emission Level – Limit value
4. The other emission levels were very low against the limit.
5. " * ": Fundamental frequency.

CHANNEL	TX Channel 78	DETECTOR FUNCTION	Peak (PK)
FREQUENCY RANGE	1GHz ~ 25GHz		Average (AV)

ANTENNA POLARITY & TEST DISTANCE: HORIZONTAL AT 3 M								
NO.	FREQ. (MHz)	EMISSION LEVEL (dBuV/m)	LIMIT (dBuV/m)	MARGIN (dB)	ANTENNA HEIGHT (m)	TABLE ANGLE (Degree)	RAW VALUE (dBuV)	CORRECTION FACTOR (dB/m)
1	*2480.00	105.6 PK			1.20 H	17	107.8	-2.2
2	*2480.00	105.1 AV			1.20 H	17	107.3	-2.2
3	2483.50	54.3 PK	74.0	-19.7	1.20 H	17	56.5	-2.2
4	2483.50	40.0 AV	54.0	-14.0	1.20 H	17	42.2	-2.2
5	4960.00	40.5 PK	74.0	-33.5	1.76 H	112	38.0	2.5
6	4960.00	28.4 AV	54.0	-25.6	1.76 H	112	25.9	2.5
7	7440.00	46.2 PK	74.0	-27.8	1.42 H	136	37.8	8.4
8	7440.00	34.9 AV	54.0	-19.1	1.42 H	136	26.5	8.4

ANTENNA POLARITY & TEST DISTANCE: VERTICAL AT 3 M								
NO.	FREQ. (MHz)	EMISSION LEVEL (dBuV/m)	LIMIT (dBuV/m)	MARGIN (dB)	ANTENNA HEIGHT (m)	TABLE ANGLE (Degree)	RAW VALUE (dBuV)	CORRECTION FACTOR (dB/m)
1	*2480.00	91.9 PK			2.90 V	296	94.1	-2.2
2	*2480.00	91.4 AV			2.90 V	296	93.6	-2.2
3	2483.50	54.4 PK	74.0	-19.6	2.90 V	296	56.6	-2.2
4	2483.50	39.1 AV	54.0	-14.9	2.90 V	296	41.3	-2.2
5	4960.00	40.0 PK	74.0	-34.0	3.26 V	48	37.5	2.5
6	4960.00	28.1 AV	54.0	-25.9	3.26 V	48	25.6	2.5
7	7440.00	45.5 PK	74.0	-28.5	2.39 V	46	37.1	8.4
8	7440.00	34.2 AV	54.0	-19.8	2.39 V	46	25.8	8.4

REMARKS:

1. Emission Level(dBuV/m) = Raw Value(dBuV) + Correction Factor(dB/m)
2. Correction Factor(dB/m) = Antenna Factor(dB/m) + Cable Factor(dB) – Pre-Amplifier Factor(dB)
3. Margin value = Emission Level – Limit value
4. The other emission levels were very low against the limit.
5. " * ": Fundamental frequency.

Below 1GHz Data:

BT_8DPSK

CHANNEL	TX Channel 78	DETECTOR FUNCTION	Quasi-Peak (QP)
FREQUENCY RANGE	9kHz ~ 1GHz		

ANTENNA POLARITY & TEST DISTANCE: HORIZONTAL AT 3 M								
NO.	FREQ. (MHz)	EMISSION LEVEL (dBuV/m)	LIMIT (dBuV/m)	MARGIN (dB)	ANTENNA HEIGHT (m)	TABLE ANGLE (Degree)	RAW VALUE (dBuV)	CORRECTION FACTOR (dB/m)
1	31.74	30.0 QP	40.0	-10.0	2.00 H	132	39.4	-9.4
2	56.12	27.2 QP	40.0	-12.8	1.50 H	141	35.8	-8.6
3	116.86	26.3 QP	43.5	-17.2	1.50 H	61	36.4	-10.1
4	198.71	24.9 QP	43.5	-18.6	1.50 H	277	35.0	-10.1
5	290.10	25.3 QP	46.0	-20.7	2.00 H	103	32.2	-6.9
6	499.82	27.0 QP	46.0	-19.0	1.50 H	162	28.4	-1.4

REMARKS:

1. Emission Level(dBuV/m) = Raw Value(dBuV) + Correction Factor(dB/m)
2. Correction Factor(dB/m) = Antenna Factor(dB/m) + Cable Factor(dB) – Pre-Amplifier Factor(dB)
3. Margin value = Emission Level – Limit value
4. The other emission levels were very low against the limit of frequency range 30MHz~1000MHz.
5. The emission levels were very low against the limit of frequency range 9kHz~30MHz: the amplitude of spurious emissions attenuated more than 20 dB below the permissible value to be report.

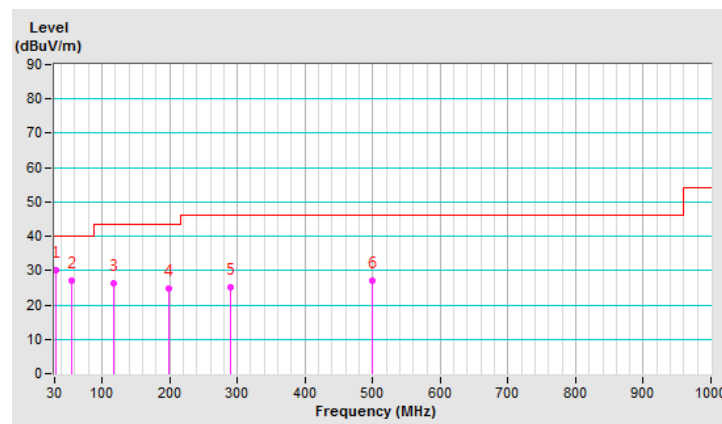

CHANNEL	TX Channel 78	DETECTOR FUNCTION	Quasi-Peak (QP)
FREQUENCY RANGE	9kHz ~ 1GHz		

ANTENNA POLARITY & TEST DISTANCE: VERTICAL AT 3 M								
NO.	FREQ. (MHz)	EMISSION LEVEL (dBuV/m)	LIMIT (dBuV/m)	MARGIN (dB)	ANTENNA HEIGHT (m)	TABLE ANGLE (Degree)	RAW VALUE (dBuV)	CORRECTION FACTOR (dB/m)
1	31.18	30.3 QP	40.0	-9.7	1.50 V	199	39.8	-9.5
2	145.83	29.0 QP	43.5	-14.5	2.00 V	173	36.7	-7.7
3	189.00	28.2 QP	43.5	-15.3	1.00 V	182	38.0	-9.8
4	329.99	24.9 QP	46.0	-21.1	1.00 V	89	30.4	-5.5
5	500.09	34.2 QP	46.0	-11.8	1.00 V	68	35.6	-1.4
6	521.13	29.4 QP	46.0	-16.6	1.50 V	79	30.5	-1.1

REMARKS:

1. Emission Level(dBuV/m) = Raw Value(dBuV) + Correction Factor(dB/m)
2. Correction Factor(dB/m) = Antenna Factor(dB/m) + Cable Factor(dB) – Pre-Amplifier Factor(dB)
3. Margin value = Emission Level – Limit value
4. The other emission levels were very low against the limit of frequency range 30MHz~1000MHz.
5. The emission levels were very low against the limit of frequency range 9kHz~30MHz: the amplitude of spurious emissions attenuated more than 20 dB below the permissible value to be report.

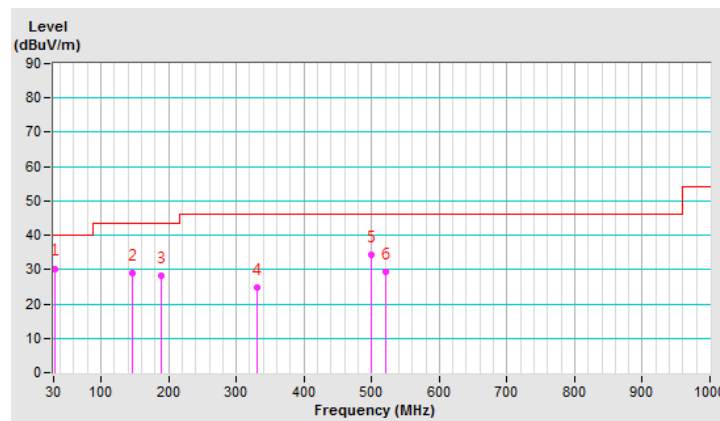

4.2 Maximum Output Power

4.2.1 Limits of Maximum Output Power Measurement

The Maximum Output Power Measurement is 125mW.

4.2.2 Test Setup

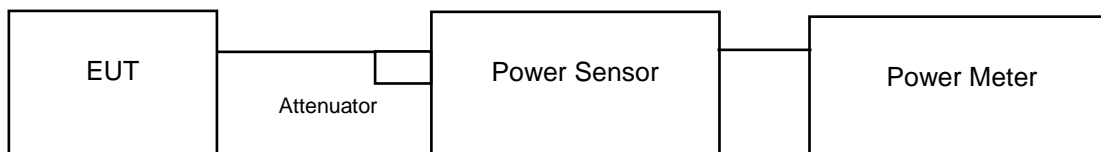

4.2.3 Test Instruments

Refer to section 4.1.2 to get information of above instrument.

4.2.4 Test Procedure

A peak power sensor was used on the output port of the EUT. A power meter was used to read the response of the peak power sensor. Record the power level.

Average power sensor was used to perform output power measurement, trigger and gating function of wide band power meter is enabled to measure max output power of TX on burst. Duty factor is not added to measured value.

4.2.5 Deviation from Test Standard

No deviation.

4.2.6 EUT Operating Condition

The software provided by client enabled the EUT to transmit and receive data at lowest, middle and highest channel frequencies individually.

4.2.7 Test Results

FOR PEAK POWER

Channel	Frequency (MHZ)	GFSK		8DPSK		Power Limit (mW)	Pass / Fail
		Output Power (mW)	Output Power (dBm)	Output Power (mW)	Output Power (dBm)		
0	2402	1.888	2.76	4.656	6.68	125	Pass
39	2441	1.995	3.00	5.534	7.43	125	Pass
78	2480	1.879	2.74	5.521	7.42	125	Pass

FOR AVERAGE POWER

Channel	Frequency (MHZ)	GFSK		8DPSK	
		Average Power (mW)	Average Power (dBm)	Average Power (mW)	Average Power (dBm)
0	2402	1.866	2.71	2.825	4.51
39	2441	1.959	2.92	3.048	4.84
78	2480	1.845	2.66	3.097	4.91

5 Pictures of Test Arrangements

Please refer to the attached file (Test Setup Photo).

Appendix – Information of the Testing Laboratories

We, Bureau Veritas Consumer Products Services (H.K.) Ltd., Taoyuan Branch, were founded in 1988 to provide our best service in EMC, Radio, Telecom and Safety consultation. Our laboratories are FCC recognized accredited test firms and accredited according to ISO/IEC 17025.

If you have any comments, please feel free to contact us at the following:

Lin Kou EMC/RF Lab

Tel: 886-2-26052180

Fax: 886-2-26051924

Hsin Chu EMC/RF/Telecom Lab

Tel: 886-3-6668565

Fax: 886-3-6668323

Hwa Ya EMC/RF/Safety Lab

Tel: 886-3-3183232

Fax: 886-3-3270892

Email: service.adt@tw.bureauveritas.com

Web Site: www.bureauveritas-adt.com

The address and road map of all our labs can be found in our web site also.

--- END ---