

Photographs of test setup

1-1: Photograph of platform and antenna position

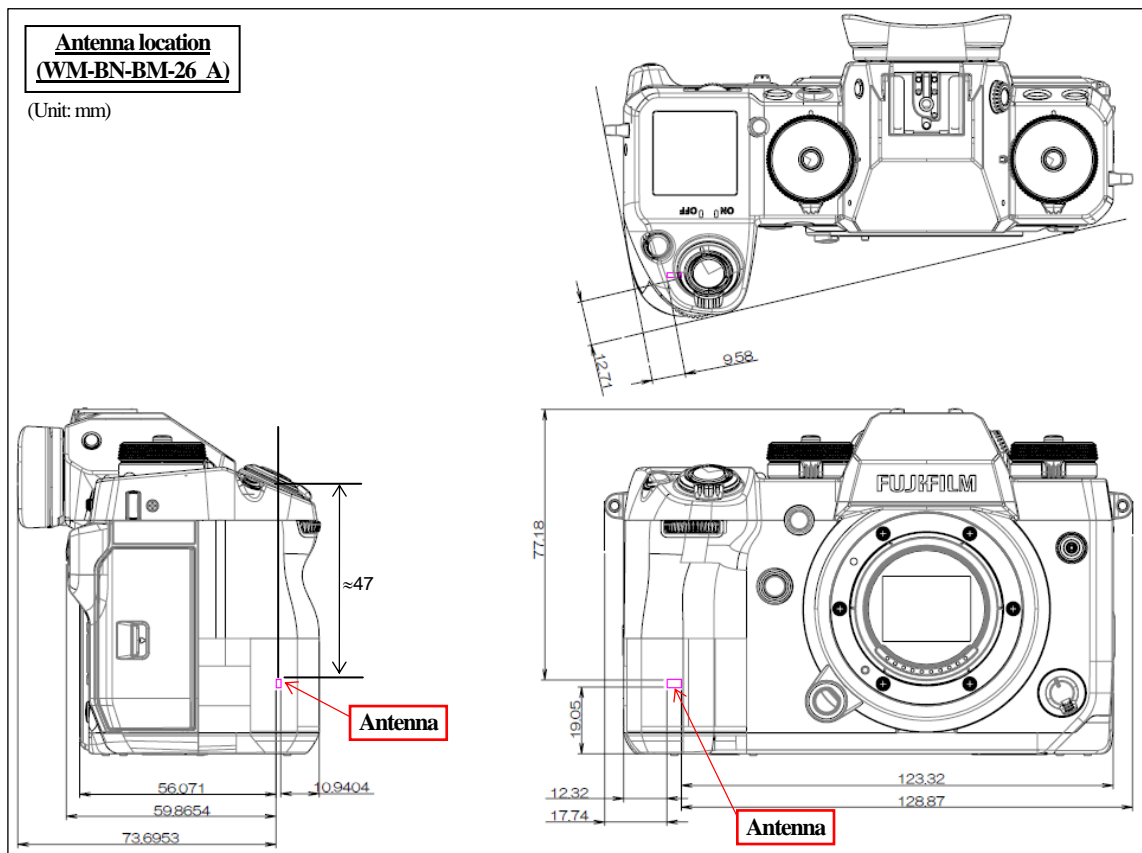

1-2: EUT and support equipment

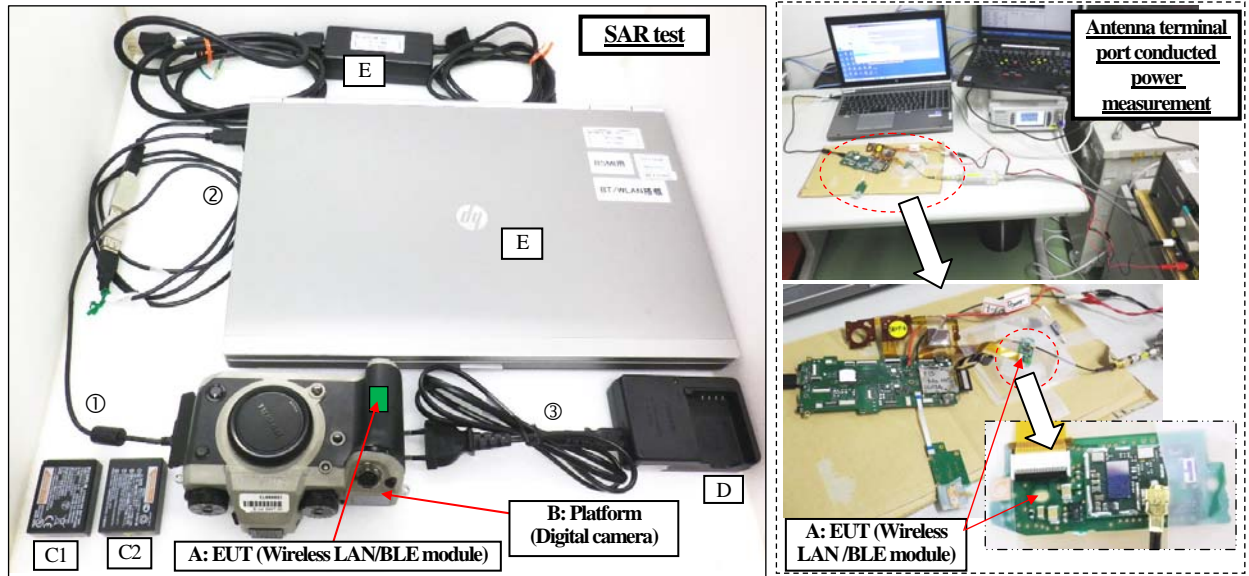

Description of EUT and Support Equipment

No.	Item	Model number	Serial number	Manufacturer	Remark
A	802.11b/g/n + BT Wireless LAN Module	WM-BN-BM-26_A	E04F43433059	Universal Global Scientific Industrial Co., Ltd.	EUT
B	Digital Camera	FF170002	15000073	Fujifilm Corporation	Platform
C1	Lithium Ion Battery (DC 7.2V, typ.1260 mAh, 8.7 Wh)	NP-W126S	01	Fujifilm Corporation	*. Accessory of EUT. Battery ID: #1.
C2			02		*. Accessory of EUT. Battery ID: #2.
D	Battery Charger	BC-W126	01	Fujifilm Corporation	Support equipment.
E	Notebook PC (#SRE-111)	E1Q57PA#ABJ	L3-NHT3R_05/07	Hewlett Packard	Support equipment.
	AC Adaptor	M/N: PPP009L-E	3453442403	Hewlett Packard	DC cable: 1.7m, Unshielded. AC cable: 1.7m, Unshielded.

List of cables used





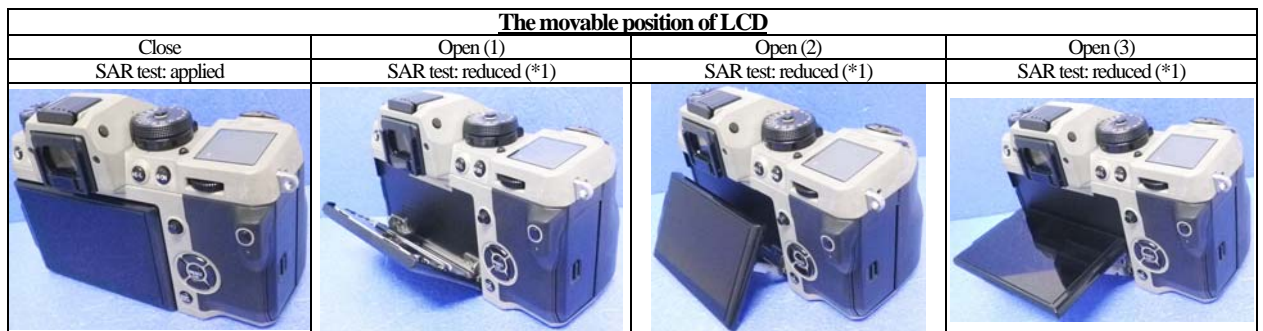







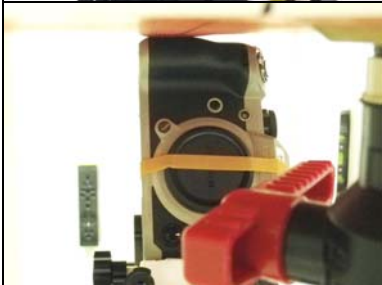

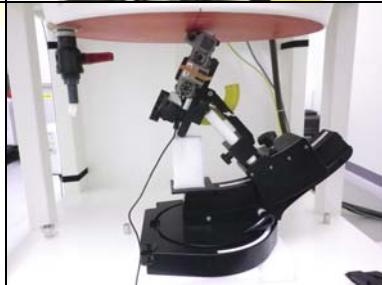

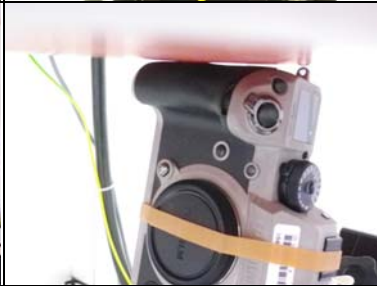
No.	Name	Length (m)	Shield
①	USB cable (*. Accessory of digital camera)	0.55	Shielded
②	USB extension cable	1.4	Shielded

No.	Name	Length (m)	Shield
③	AC cable (For item #D)	0.8	Unshielded















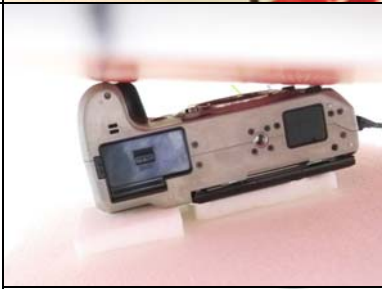

*1. An antenna is located in a point of a right hand grip. Therefore SAR inspection by the location of the LCD was reduced because an antenna was away from the LCD enough.

1-3: Photograph of test setup

Position	Setup photographs		
Right-front (Touch)			
			
Right (Touch)			
			
Front-right (Touch)			
			

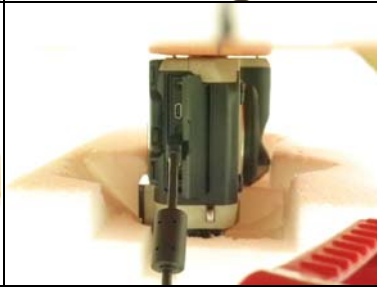
1-3: Photograph of test setup (cont'd)

Position	Setup photographs		
Front (Touch)			
			
Front-lens (Touch)			
			
Bottom (Touch)			
		(No photograph)	(No photograph)