

UNLESS OTHERWISE SPECIFIED:

1. ALL DIMENSIONS ARE IN MILLIMETERS.
2. DO NOT SCALE; ARTWORK 1:1.

Requirements for the North American/EU/Aus/NZ. (Label #1):

| REV | ECO/DESCRIPTION | DATE | APPROVED |
|-----|---|------------|---------------|
| A | Preliminary Certification mark for NA/EU/Aus/NZ | 2016-06-28 | SENKA BERGMAN |
| B | Preliminary Certification mark for NA/EU/Aus/NZ | 2016-07-29 | SENKA BERGMAN |

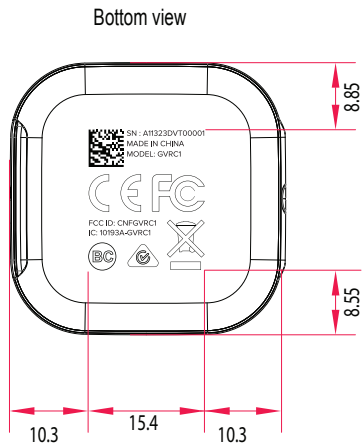

ARTWORK
100%

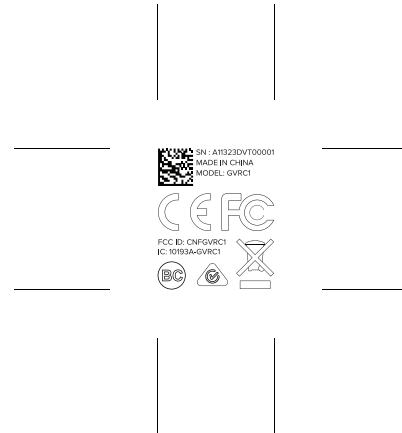

| Compliance icons/Laser Etching Color | |
|--------------------------------------|-------------------|
| Label/ICONS | PMS COOL GRAY 11C |

| TOLERANCE TABLE 1.0 | | |
|---------------------|--------------|--------------|
| DIMENSION RANGE | DECIMAL X.X | DECIMAL X.XX |
| 0.00 to 6.35 | +/- 0.3 | +/- 0.13 |
| 6.36 to 38.10 | +/- 0.3 | +/- 0.13 |
| ANGULAR | +/- 1 DEGREE | +/- 1 DEGREE |

| | |
|------------------------------|--------------------|
| PREPARED BY SENKA BERGMAN | DATE 2016-07-29 |
| CHECKED BY | DATE |
| PROJ FILENAME | |

PARTS MUST BE RoHS COMPLIANT

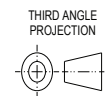

ALL DIMENSIONS ARE MILLIMETERS

| | | |
|--|------------------------------|--------------|
| | | |
| PART DESCRIPTION ARTWORK, LABEL, COMPLIANCE, SNIPER | | |
| SIZE A3 | DRAWING NUM 448-19166-000 | REV B |
| DO NOT SCALE DRAWING | | SHEET 1 OF 1 |

THIS ENGINEERING DRAWING AND SPECIFICATION CONTAINS CONFIDENTIAL, TRADE SECRET, AND OTHER PROPRIETARY INFORMATION OF GoPro. THIS DOCUMENT MAY NOT BE TRANSFERRED OR COPIED WITHOUT THE EXPRESS WRITTEN AUTHORIZATION OF GoPro. IN ADDITION, NEITHER THIS SHEET NOR THE INFORMATION IT CONTAINS MAY BE USED BY OR DISCLOSED TO ANY THIRD PARTY WITHOUT GoPro's EXPRESS WRITTEN CONSENT.

UNLESS OTHERWISE SPECIFIED:

1. ALL DIMENSIONS ARE IN MILLIMETERS.
2. DO NOT SCALE; ARTWORK 1:1.

Requirements for the Asian Label (Label #2):

| REV | ECO/DESCRIPTION | DATE | APPROVED |
|-----|---|------------|---------------|
| A | Preliminary Certification mark for Asia | 2016-07-01 | SENKA BERGMAN |
| B | Preliminary Certification mark for Asia | 2016-07-29 | SENKA BERGMAN |

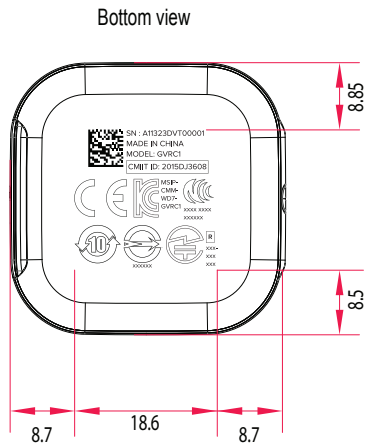

ARTWORK
100%



| Compliance icons/Laser Etching Color | |
|--------------------------------------|-------------------|
| Label/ICONS | PMS COOL GRAY 11C |

| TOLERANCE TABLE 1.0 | | |
|---------------------|--------------|--------------|
| DIMENSION RANGE | DECIMAL X.X | DECIMAL X.XX |
| 0.00 to 6.35 | +/- 0.3 | +/- 0.13 |
| 6.36 to 38.10 | +/- 0.3 | +/- 0.13 |
| ANGULAR | +/- 1 DEGREE | +/- 1 DEGREE |

| | |
|--------------------------------|------------------------|
| PREPARED BY SENKA BERGMAN | DATE 2016-07-29 |
| CHECKED BY | DATE |
| PROJ. FILENAME | |
| PARTS MUST BE RoHS COMPLIANT | THIRD ANGLE PROJECTION |
| ALL DIMENSIONS ARE MILLIMETERS | |

| | | |
|--|------------------------------|--------------|
| | | |
| PART DESCRIPTION ARTWORK, LABEL, COMPLIANCE, SNIPER | | |
| SIZE A3 | DRAWING NUM 448-19166-000 | REV B |
| DO NOT SCALE DRAWING | | SHEET 1 OF 2 |

THIS ENGINEERING DRAWING AND SPECIFICATION CONTAINS CONFIDENTIAL, TRADE SECRET, AND OTHER PROPRIETARY INFORMATION OF GoPro. THIS DOCUMENT MAY NOT BE TRANSFERRED OR COPIED WITHOUT THE EXPRESS WRITTEN AUTHORIZATION OF GoPro. IN ADDITION, NEITHER THIS SHEET NOR THE INFORMATION IT CONTAINS MAY BE USED BY OR DISCLOSED TO ANY THIRD PARTY WITHOUT GoPro's EXPRESS WRITTEN CONSENT.

UNLESS OTHERWISE SPECIFIED:

1. ALL DIMENSIONS ARE IN MILLIMETERS.
2. DO NOT SCALE; ARTWORK 1:1.

Requirements for the Latin America Label (Label #3):

| REV | ECO/DESCRIPTION | DATE | APPROVED |
|-----|--|------------|---------------|
| A | Preliminary Certification mark for Latin America | 2016-07-01 | SENKA BERGMAN |
| B | Preliminary Certification mark for Latin America | 2016-07-29 | SENKA BERGMAN |

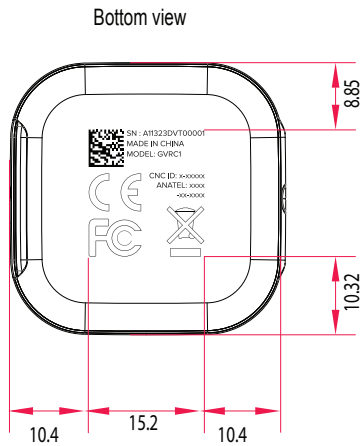

ARTWORK
100%

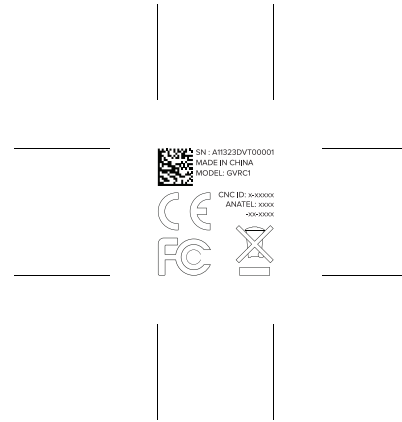

| Compliance icons/Laser Etching Color | |
|--------------------------------------|-------------------|
| Label/ICONS | PMS COOL GRAY 11C |

| TOLERANCE TABLE 1.0 | | |
|---------------------|--------------|--------------|
| DIMENSION RANGE | DECIMAL X.X | DECIMAL X.XX |
| 0.00 to 6.35 | +/- 0.3 | +/- 0.13 |
| 6.36 to 38.10 | +/- 0.3 | +/- 0.13 |
| ANGULAR | +/- 1 DEGREE | +/- 1 DEGREE |

| | |
|------------------------------|--------------------|
| PREPARED BY SENKA BERGMAN | DATE 2016-07-29 |
| CHECKED BY | DATE |
| PROJ FILENAME | |

PARTS MUST BE RoHS
COMPLIANT

THIRD ANGLE
PROJECTION



PART DESCRIPTION
ARTWORK, LABEL, COMPLIANCE, SNIPER

| | | |
|------------|------------------------------|----------|
| SIZE A3 | DRAWING NUM 448-19166-000 | REV B |
|------------|------------------------------|----------|

DO NOT SCALE DRAWING SHEET 1 OF 3

THIS ENGINEERING DRAWING AND SPECIFICATION CONTAINS CONFIDENTIAL, TRADE SECRET, AND OTHER PROPRIETARY INFORMATION OF GoPro. THIS DOCUMENT MAY NOT BE TRANSFERRED OR COPIED WITHOUT THE EXPRESS WRITTEN AUTHORIZATION OF GoPro. IN ADDITION, NEITHER THIS SHEET NOR THE INFORMATION IT CONTAINS MAY BE USED BY OR DISCLOSED TO ANY THIRD PARTY WITHOUT GoPro's EXPRESS WRITTEN CONSENT.

UNLESS OTHERWISE SPECIFIED:

1. ALL DIMENSIONS ARE IN MILLIMETERS.
2. DO NOT SCALE; ARTWORK 1:1.

Requirements for the Rest of World Label (Label #4):

ARTWORK
100%

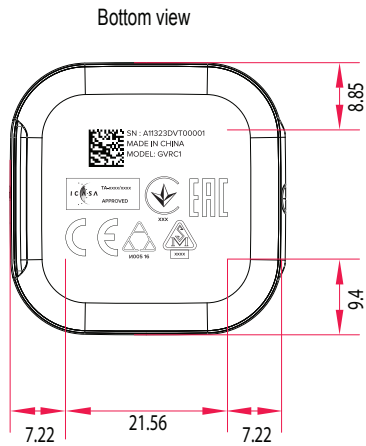

| Compliance icons/Laser Etching Color | |
|--------------------------------------|-------------------|
| Label/ICONS | PMS COOL GRAY 11C |

| TOLERANCE TABLE 1.0 | | |
|---------------------|--------------|--------------|
| DIMENSION RANGE | DECIMAL X.X | DECIMAL X.XX |
| 0.00 to 6.35 | +/- 0.3 | +/- 0.13 |
| 6.36 to 38.10 | +/- 0.3 | +/- 0.13 |
| ANGULAR | +/- 1 DEGREE | +/- 1 DEGREE |

| | |
|--------------------------------|------------------------|
| PREPARED BY SENKA BERGMAN | DATE 2016-07-29 |
| CHECKED BY | DATE |
| PROJ. FILENAME | |
| PARTS MUST BE RoHS COMPLIANT | THIRD ANGLE PROJECTION |
| ALL DIMENSIONS ARE MILLIMETERS | |

| | | |
|--|------------------------------|--------------|
| | | |
| PART DESCRIPTION ARTWORK, LABEL, COMPLIANCE, SNIPER | | |
| SIZE A3 | DRAWING NUM 448-19166-000 | REV B |
| DO NOT SCALE DRAWING | | SHEET 1 OF 4 |

THIS ENGINEERING DRAWING AND SPECIFICATION CONTAINS CONFIDENTIAL, TRADE SECRET, AND OTHER PROPRIETARY INFORMATION OF GoPro. THIS DOCUMENT MAY NOT BE TRANSFERRED OR COPIED WITHOUT THE EXPRESS WRITTEN AUTHORIZATION OF GoPro. IN ADDITION, NEITHER THIS SHEET NOR THE INFORMATION IT CONTAINS MAY BE USED BY OR DISCLOSED TO ANY THIRD PARTY WITHOUT GoPro's EXPRESS WRITTEN CONSENT.