







UNLESS OTHERWISE SPECIFIED:

1. INTERPRET DIMENSIONS PER ASME Y14.5M-1994.
2. ALL DIMENSIONS ARE IN MILLIMETERS.
3. DO NOT SCALE; ARTWORK 1:1.

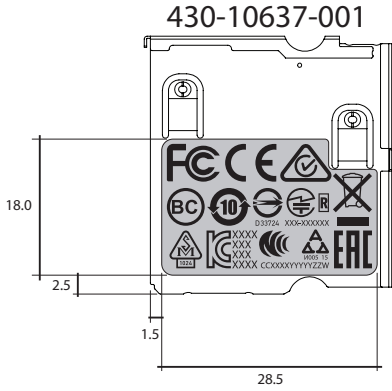
REV	ECO/DESCRIPTION	DATE	APPROVED
1	DVT	2016-2-17	S.LEE
2	Serbia Mark added  Change Taiwan BSMI  to 	2016-2-22	S.LEE
3	Change Label Dimensions	2016-2-22	S.LEE



ARTWORK
100%

Graphic	Color
	 PANTONE® BLACK C
	 PANTONE® 877 C

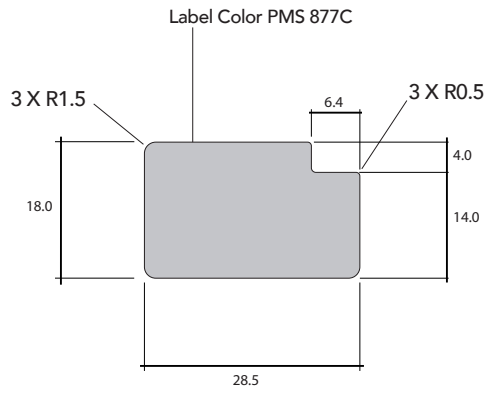

LABEL
100%

TOLERANCE TABLE 1.0		
DIMENSION RANGE	DECIMAL X.X	DECIMAL X.XX
0.00 to 6.35	+/- 0.3	+/- 0.13
6.36 to 38.10	+/- 0.3	+/- 0.13
ANGULAR	+/- 1 DEGREE	+/- 1 DEGREE

PREPARED BY S.Lee	DATE 2016-2-22
CHECKED BY S.Lee	DATE 2016-2-22
PROJ. FILENAME N/A	
PARTS MUST BE RoHS COMPLIANT	THIRD ANGLE PROJECTION 
ALL DIMENSIONS ARE MILLIMETERS	





GoPro Be a HERO. 		
PART DESCRIPTION ARTWORK, LABEL, REGULATORY, COMPARTMENT, TOP, BATTERY, AUSTRALIA		
SIZE A3	DRAWING NUM 448-16869-000	REV 3
DO NOT SCALE DRAWING		SHEET 1 OF 1

THIS ENGINEERING DRAWING AND SPECIFICATION CONTAINS CONFIDENTIAL, TRADE SECRET, AND OTHER PROPRIETARY INFORMATION OF GoPro. THIS DOCUMENT MAY NOT BE TRANSFERRED OR COPIED WITHOUT THE EXPRESS WRITTEN AUTHORIZATION OF GoPro. IN ADDITION, NEITHER THIS SHEET NOR THE INFORMATION IT CONTAINS MAY BE USED BY OR DISCLOSED TO ANY THIRD PARTY WITHOUT GoPro's EXPRESS WRITTEN CONSENT.

UNLESS OTHERWISE SPECIFIED:

1. INTERPRET DIMENSIONS PER ASME Y14.5M-1994.
2. ALL DIMENSIONS ARE IN MILLIMETERS.
3. DO NOT SCALE; ARTWORK 1:1.

REV	ECO/DESCRIPTION	DATE	APPROVED
1	DVT	2016-2-17	S.LEE
2	Add 型號 中國製造	2016-2-22	S.LEE
3	DVT S/N, Bar code added.	2016-5-26	S.LEE
4	Bar Code Maximum Size Changed. Artwork Name Changed from "REGULATORY" to "SERIAL"	2016-6-2	S.LEE

Graphic	Color
<p>GoPro</p> <p>FCC ID:CNFASST1 REG#型號:ASST1 IC:10193A-ASST1 CNC ID:C-XXXXX CMT ID:XXXXYZNNNN ANATEL:XXXX-YY-XXXX Made in China 中國製造</p>	 <p>PANTONE® BLACK C</p>
	 <p>PANTONE® 877 C</p>
<p>C123110 0000000</p> 	 <p>PANTONE® BLACK C</p>

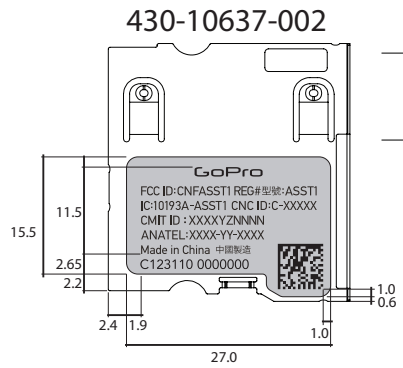

GoPro
FCC ID:CNFASST1 REG#型號:ASST1
IC:10193A-ASST1 CNC ID:C-XXXXX
CMT ID:XXXXYZNNNN
ANATEL:XXXX-YY-XXXX
Made in China 中國製造

C123110 0000000



ARTWORK
100%

ARTWORK
100%

C123110 0000000



< 6.5mm

< 6.5mm

Label Color PMS 877C

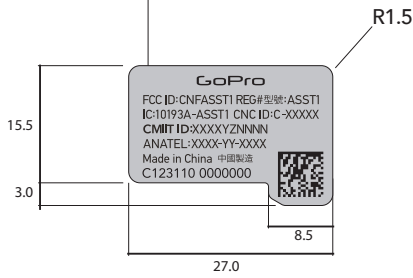

LABEL
100%

C123110 0000000



- BARCODE NOTES:
- Must be 2D Data Matrix ECC200 code
 - Contain only the serial number
 - Printed at minimum of 300 dpi
 - Must meet a verification score of A

- SERIAL NUMBER NOTES:
- Font should be San Serif-
Recommend Avenir or Arial Regular

BARCODE/SERIAL NO. ARE NOT GENERATED FROM ARTWORK.
This is serialized and needs to be created from thermal printing system. Color should be darker than base color of label. Minimum contrast for barcode scanning. Refer to 970-10723-000

TOLERANCE TABLE 1.0		
DIMENSION RANGE	DECIMAL X.X	DECIMAL X.XX
0.00 to 6.35	+/- 0.3	+/- 0.13
6.36 to 38.10	+/- 0.3	+/- 0.13
ANGULAR	+/- 1 DEGREE	+/- 1 DEGREE

PREPARED BY S.Lee	DATE 2016-6-2
CHECKED BY S.Lee	DATE 2016-6-2
PROJ FILENAME N/A	



PARTS MUST BE RoHS COMPLIANT

THIRD ANGLE PROJECTION



PART DESCRIPTION
ARTWORK,LABEL,SERIAL,COMPARTMENT, BOTTOM, BATTERY, AUSTRALIA

ALL DIMENSIONS ARE MILLIMETERS

SIZE A3	DRAWING NUM 448-16871-000	REV 4
------------	------------------------------	----------

THIS ENGINEERING DRAWING AND SPECIFICATION CONTAINS CONFIDENTIAL, TRADE SECRET, AND OTHER PROPRIETARY INFORMATION OF GoPro. THIS DOCUMENT MAY NOT BE TRANSFERRED OR COPIED WITHOUT THE EXPRESS WRITTEN AUTHORIZATION OF GoPro. IN ADDITION, NEITHER THIS SHEET NOR THE INFORMATION IT CONTAINS MAY BE USED BY OR DISCLOSED TO ANY THIRD PARTY WITHOUT GoPro's EXPRESS WRITTEN CONSENT.

DO NOT SCALE DRAWING SHEET 1 OF 1