



## Product Development

### *IR LRM2 Radio Module*

**Document p/n: 9S02-9027-A002 Rev.A**

#### CONFIDENTIALITY NOTICE

This correspondence and all information contained within are the exclusive, confidential and proprietary property of Cattron North America Inc. it is not to be reproduced, nor is it or any portion of it to be used by or disclosed to any other individual or legal entity, without the prior, written approval of Cattron North America Inc. Furthermore, the information contained within this correspondence is also to be handled in accordance with any and all confidentiality agreements between Cattron North America Inc. and the receiver or user of this information.

© 2020 Cattron North America Inc.

## Revision History

Date	Revision	Description	Signature / Date	
2020-05-10	A	Initial draft	Prepared	H. Lin
			Verified	
			Approved	
			Prepared	
			Verified	
			Approved	
			Prepared	
			Verified	
			Approved	
			Prepared	
			Verified	
			Approved	

# Table of Contents

<b>1. INTRODUCTION .....</b>	<b>1-6</b>
1.1 PURPOSE.....	1-6
1.2 SCOPE.....	1-6
1.3 APPLICABILITY .....	1-6
1.4 DEFINITIONS, ACRONYMS .....	1-6
1.4.1 Definitions .....	1-6
1.4.2 Acronyms.....	1-6
1.5 REFERENCES.....	1-6
<b>2. FEATURES SUMMARY .....</b>	<b>2-1</b>
<b>3. HOST INTERFACE DEFINITION.....</b>	<b>3-2</b>
3.1 PINS ASSIGNMENT .....	3-2
3.2 SIGNALS DESCRIPTION .....	3-3
<b>4. FUNCTIONAL DESCRIPTION.....</b>	<b>4-5</b>
4.1 OVERVIEW.....	4-5
4.1.1 IR LRM2 Radio .....	4-5
4.1.2 Data Communication Model & Definitions.....	4-5
4.2 TELEGRAM TRANSMISSION.....	4-6
4.3 TELEGRAM RECEPTION .....	4-6
<b>5. IR LRM2 CONFIGURATION CONCEPT .....</b>	<b>5-8</b>
5.1 CONSOLE INTERFACE .....	5-8
5.1.1 “Write” command.....	5-8
5.1.2 “Read” command.....	5-8
5.1.3 “Help” command .....	5-8
5.2 STAND-ALONE TEST MODE.....	5-8

90273 TRX module meets Part 15 of the FCC rules and regulations. Compliance with the labeling requirements, FCC notices is required. In order to comply with FCC Certification requirements, the Original Equipment Manufacturer (OEM) must fulfill the following requirements.

1. The system integrator must place an exterior label on the outside of the final product housing the 90273 TRX Module. The figure below shows the contents that must be included in this label.
2. 90273TRX modules may only be used with the antennas that have been tested and approved for use with the module.

### Labeling Requirements

The OEM must make sure that FCC labeling requirements are met. This includes a clearly visible exterior label on the outside of the final product housing that displays the contents shown in below.

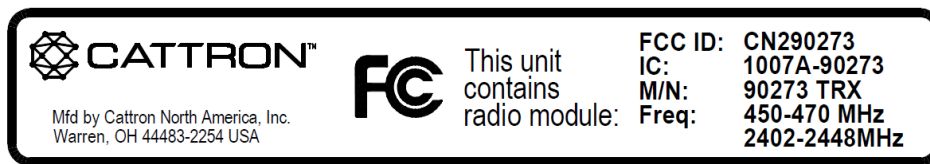

**WARNING:** The 90273 TRX modules have been tested by the FCC for use with other products without further certification (as per FCC Section 2.1091). Changes or modifications to this device not expressly approved by Cattron North America Inc. could void the user's authority to operate the equipment.

**NOTICE:** OEM's must verify the final product complies with unintentional radiators (FCC Section 15.107 and 15.109) before providing a declaration of conformity for their final product to Part 15 of the FCC Rules.

**NOTICE:** The 90273TRX modules have been certified for mobile and fixed radio applications. If the module will be used for portable applications, the device must undergo SAR testing.

**RF Exposure WARNING:** This equipment complies with FCC radiation exposure limits set forth for an uncontrolled environment. This equipment should be installed and operated with minimum distance 20 cm between the radiator and your body. This transmitter must not be co-located or operating in conjunction with any other antenna or transmitter.

**NOTICE:** The preceding statement must be included as a CAUTION statement in OEM product manuals in order to alert users of FCC RF Exposure compliance.

90275TRX is designed for use in countless wireless applications requiring long range communications with low energy consumption. To ensure that the final product complies with the all of the regulatory requirements for the Modular Grant the following integration instructions should be followed.

90275TRX is limited to OEM installation ONLY. The OEM integrator is responsible for ensuring that the end-user has no manual instructions to remove or install the module.

**FCC Part 15.19 Warning Statement**

THIS DEVICE COMPLIES WITH PART 15 OF THE FCC RULES. OPERATION IS SUBJECT TO THE FOLLOWING TWO CONDITIONS: (1) THIS DEVICE MAY NOT CAUSE HARMFUL INTERFERENCE, AND (2) THIS DEVICE MUST ACCEPT ANY INTERFERENCE RECEIVED, INCLUDING INTERFERENCE THAT MAY CAUSE UNDESIRE OPERATION.

**FCC Part 15.21 Warning Statement**

NOTE: THE **GRANTEE** IS NOT RESPONSIBLE FOR ANY CHANGES OR MODIFICATIONS NOT EXPRESSLY APPROVED BY THE PARTY RESPONSIBLE FOR COMPLIANCE. SUCH MODIFICATIONS COULD VOID THE USER'S AUTHORITY TO OPERATE THE EQUIPMENT.

**FCC Part 15.105(b) Warning Statement- (ONLY Required for 15.109-JBP devices)**

NOTE: This equipment has been tested and found to comply with the limits for a Class B digital device, pursuant to part 15 of the FCC Rules. These limits are designed to provide reasonable protection against harmful interference in a residential installation. This equipment generates uses and can radiate radio frequency energy and, if not installed and used in accordance with the instructions, may cause harmful interference to radio communications. However, there is no guarantee that interference will not occur in a particular installation. If this equipment does cause harmful interference to radio or television reception, which can be determined by turning the equipment off and on, the user is encouraged to try to correct the interference by one or more of the following measures:

- Reorient or relocate the receiving antenna.
- Increase the separation between the equipment and receiver.
- Connect the equipment into an outlet on a circuit different from that to which the receiver is connected.
- Consult the dealer or an experienced radio/TV technician for help.

**IC RSS-GEN, Sec 8.4 Warning Statement**

**ENGLISH:**

This device complies with Industry Canada license-exempt RSS standard(s). Operation is subject to the following two conditions: (1) this device may not cause interference, and (2) this device must accept any interference, including interference that may cause undesired operation of the device.

**FRENCH:**

Le présent appareil est conforme aux CNR d'Industrie Canada applicables aux appareils radio exempts de licence. L'exploitation est autorisée aux deux conditions suivantes : (1) l'appareil ne doit pas produire de brouillage, et (2) l'utilisateur de l'appareil doit accepter tout brouillage radioélectrique subi, même si le brouillage est susceptible d'en compromettre le fonctionnement.

Only the following authorized antennas or the antenna gain less than highest gain antenna for each band may be used with the equipment:

- 460MHz Splat patch antenna (50 Ohm, ANT-458-SP or equivalent),
- 460MHz ¼ wave whip antenna (50 Ohm, EXD450BNX or equivalent),
- 460MHz ½ wave mag Antenna (50 Ohm, B4505CS or equivalent);
- 2400MHz ½ wave dipole antenna (FW.24.SMA.M, GW.71.5153)

# 1. Introduction

## 1.1 Purpose

A new family of RF module, the LRM2 family, is being developed by Cattron North America Inc. This family is employing Silicon Labs EFR32FG13 Flex Gecko SoC (System On Chip), which is including a high performance Radio transceiver and a high performance Micro-Controller Unit.

## 1.2 Scope

This document describes the host interface signal definitions, timings, operation mode, available functionalities, and provide details about its integration to Unity products. This document does not cover RF specifications or power supply specifications.

## 1.3 Applicability

Applies to IR LRM2 family members, P/N 2PCA-9027-xxxx

## 1.4 Definitions, Acronyms

### 1.4.1 Definitions

### 1.4.2 Acronyms

IR LRM2	Radio Module
MCU	Machine Control Unit
SoC	System-On-Chip
OCU	Operator Control Unit

## 1.5 References

- [1] “Schematic Drawing for LRM2”, Cattron P/N 9D02-9027-X001
- [2] “Unity RF Telegrams Format”, Cattron P/N 9S01-7640-X101
- [3] “LRM2 Radio Module – Configuration Registers Specifications”, Cattron P/N 9S02-8969-A002

## 2. Features Summary

The IR LRM2 is designed to replace Remtron products with less cost and improved performance. Its host interface is compatible with previous LRM(2PCA-7954-xxxx) series.

- Direct electrical compatibility to LRM (2PCA-7954-xxxx) interface
- On-board wireless SoC– The interface is controlled by an on-board Silicon Labs EFR32FG13 SoC. The EFR32FG13 Flex Gecko SoC includes both a high-performance radio transceiver and a high performance, low power Micro-Controller.
- Minimum buffers/Minimum Delay – IR LRM2 firmware is implemented to provide a “almost transparent” operation; transmission and reception delays are kept to a minimum
- Support for different Modulation modes– The IR LRM2 family is designed to support multiple different RF Modulations (2FSK and 4FSK), which is transparent to Host firmware.

These different aspects are covered in the rest of this document.

## 3. Host Interface Definition

### 3.1 Pins Assignment

Board to board connector Pin Details			
J1			
Pin number	Signal name	Pin number	Signal name
1	GND	2	GND
3	TDI-RF	4	nRESET-RF
5	MASTER-CTRL-US1-RX-M	6	RFIO-2-M
7	GND	8	MASTER-DATA-US0-TX-M
9	I2C0-SDA-RF	10	RFIO-3-M
11	I2C0-SCL-RF	12	TDO-RF
13	GND	14	MASTER-DATA-US0-RX-M
15	RFIO-1-M	16	TMS/SWDIO-RF
17	BOOT-EN/RFIO-0-M	18	TCK/SWDCLK-RF
19	GND	20	MASTER-CTRL-US1-TX-M

J5			
Pin number	Signal name	Pin number	Signal name
1	GND	2	GND
3	nRESET-M	4	3.3V
5	nRESET-S	6	3.3V
7	BOOT-EN/RFIO-0-S	8	GND
9	SLAVE-DATA-US0-RX-S	10	REV_AN
11	SLAVE-CTRL-US1-RX-S	12	RFIO-1-S
13	SLAVE-DATA-US0-TX-S	14	ANT_SEL
15	SLAVE-CTRL-US1-TX-S	16	FWD_AN
17	READY	18	READY (For PA_EN)
19	GND	20	GND

Table 3.1 – Host Interface pins assignment



### 3.2 Signals Description

Net Name	General Description
TCK/SWDCLK-RF	GPIO (5V)
TMS/SWDIO-RF	GPIO (5V)
TDO-RF	GPIO (5V)
TDI-RF	GPIO (5V)
MASTER-DATA-US0-TX-M	GPIO (5V),UART_RX for Master data signals
MASTER-DATA-US0-RX-M	GPIO (5V), UART_TX for Master data signals
RFIO-2-M	GPIO (5V), RFIO-2_Master
RFIO-3-M	GPIO (5V), RFIO-3_Master
3.3V	Radio Power Supply
38.4MHz crystal Oscillator	High Frequency Crystal input, 38.4MHz crystal Oscillator
	High Frequency Crystal output, 38.4MHz crystal Oscillator
nRESET-RF	Reset input, active low, nReset_Radio (Input from JTAG connector)
Sub GHz RF Output	Sub GHz Differential RF output, positive path
	Sub GHz Differential RF output, negative path
Sub GHz RF Input	Sub GHz Differential RF input, positive path
	Sub GHz Differential RF input, negative path
GND	Radio Ground
GND	Power Amplifier (PA) voltage regulator VSS
GND	2.4 GHz Differential RF input/output, negative path
2G4RF_IOP	2.4 GHz Differential RF input/output, positive path
PAVDD	Power Amplifier (PA) voltage regulator VDD input
nRESET-M	nRESET_M (Reset output for Master controller)
nRESET-S	nRESET_S (Reset output for Slave controller)
BOOT-EN/RFIO-0-S	RFIO-0_Slave
SLAVE-DATA-US0-RX-S	UART_TX for slave data signals
SLAVE-DATA-US0-TX-S	UART_RX for slave data signals
SLAVE-CTRL-US1-RX-S	UART_TX for Slave control signals
SLAVE-CTRL-US1-TX-S	UART_RX for Slave control signals
TCXO_EN	GPIO for TCXO_EN
TX/nRX	GPIO (5V), TX/nRX (GPIO to enable RF switch#01 & 02)
READY	GPIO for GREEN LED. Multiplexed with READY (GPIO output)
REV_AN	REV_AN
RFIO-1-S	RFIO-1_Slave
3.3V	Analog power supply
ANT_SEL	ANT_SEL (GPIO to enable RF switch#03 which will be located on MCU board)
FWD_AN	GPIO for RED LED. Multiplexed with FWD_AN (For power amplifier. It is not required in our design. Just provision for cattron team)

GND	Voltage regulator VSS
NC	Kept it NC
3.3V	3.3V Supply
3.3V	3.3V Supply
GND with decoupling cap	Decouple output for on-chip voltage regulator
3.3V	3.3V Supply
BOOT-EN/RFIO-0-M	
RFIO-1-M	RFIO-1_Master
I2C0-SCL-RF	I2C0_SCL
I2C0-SDA-RF	I2C0_SDA
MASTER-CTRL-US1-RX-M	UART_TX for Master control signals
MASTER-CTRL-US1-TX-M	UART_RX for Master control signals

**Table 3.2 - Host Interface signals description**

## 4. Functional Description

### 4.1 Overview

#### 4.1.1 IR LRM2 Radio

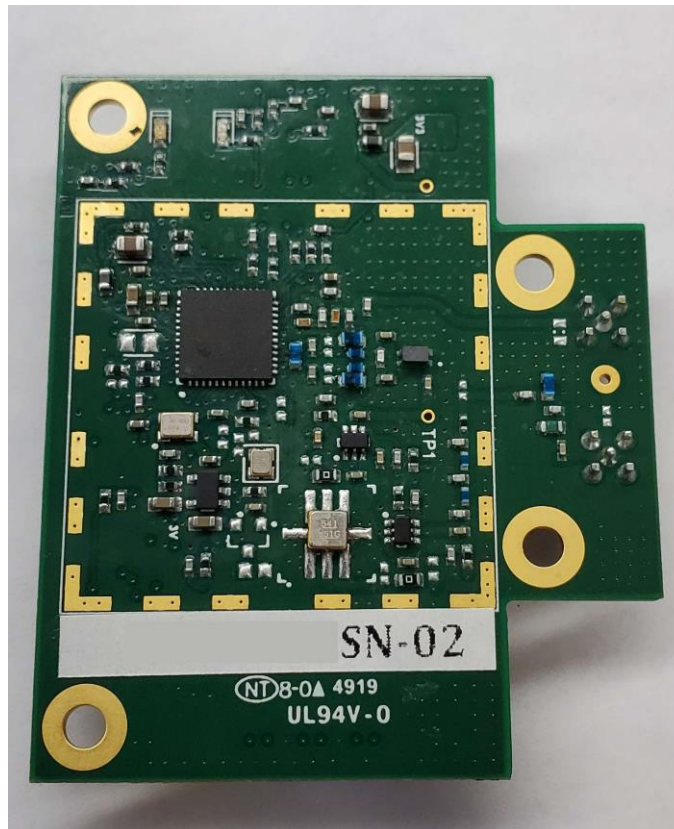

Figure 4.1 – IR LRM2 Design

The Silicon Labs ERF32FG13 SoC is located between the host interface and the RF interface, providing decoupling between host and RF interface. The ERF32FG13 SoC has sufficient buffer space for one telegram.

As shown later, telegram processing is defined to minimize delays, so to provide a “transparent-like” behavior.

Sub-GHz will support different frequency bands to support different regions & supported frequency bands are mentioned below:

- Propriety Sub-GHz protocol:
  - 433MHz
  - 460MHz
  - 868MHz
  - 915MHz

#### 4.1.2 Data Communication Model & Definitions

The communication model defines some of the terminology used in the rest of this document.

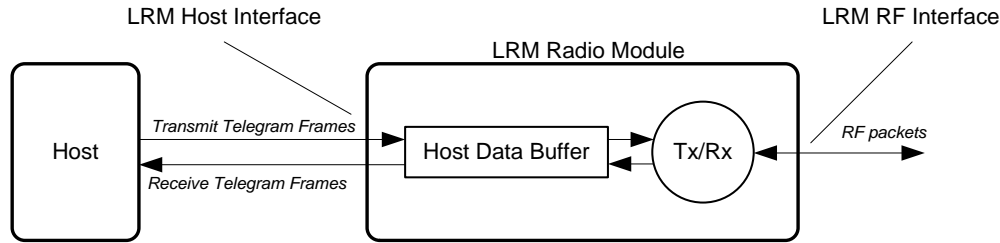

Figure 4.2 - Data communication model

- The IR LRM2 Radio Module is used to communicate telegrams between **hosts**. In Unity context, hosts are OCU and MCU CPU boards. The IR LRM2 has two interfaces: a **Host Interface** and a **RF Interface**.
- Transmit and Received Telegrams are relayed through the IR LRM2 **Host Data Buffer**. This buffer is capable to hold only one telegram at a time. The purpose of this buffer is to relax host timings requirements, and to allow decoupling between Host Interface and RF Interface data rates.
- Telegrams sent/received on the Host Interface and RF interface are encapsulated into **frames** to improve synchronization.
- The IR LRM2 does not perform any processing on the telegrams content; it controls only the frames overhead.

## 4.2 Telegram Transmission

Transmit frames have two fields:

- Telegram length (number of bytes). The length is used by the CPU to control the transmission process.
- Telegram (maximum 254 bytes). The content of the telegram is defined by the application. For Unity application, this is the Unity Telegram beginning with the Scrambling byte, the TID and terminated with the 16bits CRC, as defined in ref [2].



Figure 4.3 - Transmit Telegram frame format

## 4.3 Telegram Reception

Each RF packet received by the LRM2 is sent to the host interface, followed by its RSSI. Also, in order to ensure receive telegram frame synchronization (i.e. unambiguous detection of the start of the frame), the frame is encapsulated according to SLIP framing. SLIP framing is very simple to decode. It is described in section **Error! Reference source not found.**

Receive frame fields are:

- SOF (Start-of-Frame character). This is part of SLIP encapsulation.
- Length of the Telegram field (number of bytes), not counting RSSI fields and any additional control characters introduced for SLIP encapsulation.
- Telegram (maximum 254 bytes). The content of the telegram is defined by the application.

- RSSI: Received signal strength for this frame. RSSI is an 8 bits integer value, expressed in dBm. Range;-128 to +127 dBm.

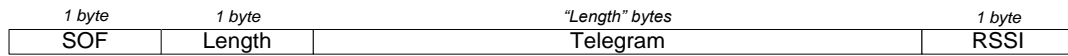

**Figure 4.4 - Receive Telegram frame format**

## 5. IR LRM2 Configuration Concept

All IR LRM2 configuration and status parameters are accessible through addressable registers.

- All parameters can be read and written only in CONFIG mode.

The definition of the configuration registers is given in reference [3]. This section addresses the basic description of all these three methods.

### 5.1 Console Interface

The Sub-GHz serial interface configuration port is enabled by asserting !CONFIG signal; the serial interface is automatically reconfigured in asynchronous mode, running at 38400bps, 8N1. All ASCII strings received are interpreted as configuration commands. This mode is particularly useful for stand-alone testing, when the unit can be controlled from a PC or by an operator/tester using a terminal emulation program.

#### 5.1.1 “Write” command

**wrCmd register value** , where:

- wrCmd = write command. “w” or “wr” can be used and are equivalent
- register = register identification. Can use the register name or register address
- value = value to be written, in decimal or hexadecimal format. Hexadecimal values are preceded by ‘0x’

#### 5.1.2 “Read” command

**rdCmd reg** where:

- rdCmd= read command. **r** or **rd** can be used and are equivalent
- reg = register identification. Can use the register name or register address

#### 5.1.3 “Help” command

**helpCmd** where:

- helpCmd= help command. **h**, **help** or **?** can be used and are equivalent.

The IR LRM2 responds with the list off all available configuration registers.

### 5.2 Stand-Alone Test Mode

The IR LRM2 can be operated in stand-alone mode for production/service tests. In this case, only a 3.3VDC supply is needed, and a RS232/TTL transceiver (like Cattron FLASHBOX) to connect to a PC serial port.

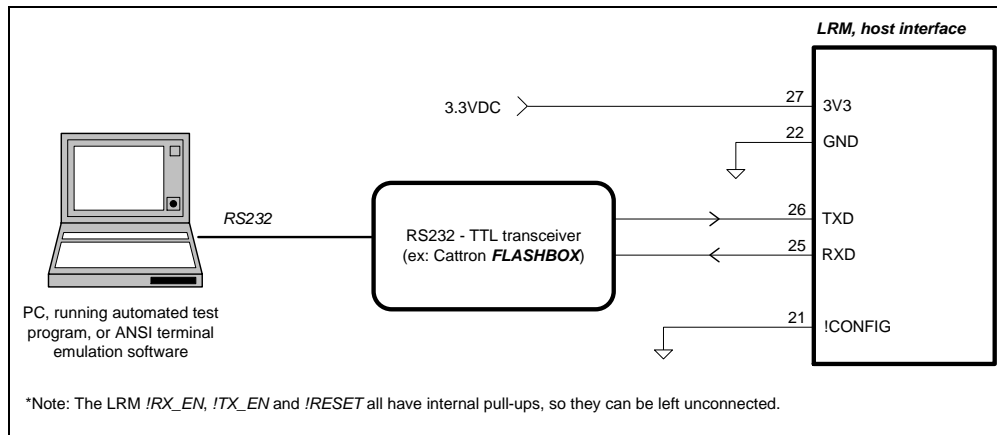

**Figure 5.1 - LRM2 connection for stand-alone operation**

The IR LRM2 will support several built-in test modes to ease testing from a PC. For example

**a. Sub-GHz Transmission Tests**

- Generation of different type of carrier: unmodulated (CW), or modulated with “101010..” or pseudo-random sequence
- Automatic generation of test RF frames with predefined content

**b. Sub-GHz Reception Tests**

- Measure PER (packet error rate) when receiving the predefined test RF frames
- Measure RF input level

**c. Bluetooth Tests**

- By using Silicon Labs application, “Wireless Gecko”, the Bluetooth channel, transmit power level, data speed could be adjusted.