



2PCA-8694-Dxxx Radio Module

9S02-8694-D001

Revision: A
Status: Approved
Date: March 20, 2023
Author: H. Lin
Filename: 9S02-8694-D001

This document and all information contained within are the exclusive, confidential and proprietary property of Cattron North America Inc (hereafter, "Cattron"). It is not to be reproduced, nor is it or any portion of it to be used by or disclosed to any other individual or legal entity, without the prior, written approval of Cattron. Furthermore, the information contained within this document is also to be handled in accordance with any and all confidentiality agreements between Cattron and the receiver or user of this document. © Copyright 2023, Cattron. All rights reserved.

REVISION HISTORY

Revision	Date	Name	Notes
A	March 20 th , 2023	H. Lin	Initial Release

TABLE OF CONTENTS

1	INTRODUCTION.....	8
1.1	PURPOSE.....	8
1.2	SCOPE.....	8
1.3	APPLICABILITY.....	8
1.4	ACRONYMS, ABBREVIATIONS.....	8
2	FEATURES SUMMARY.....	9
2.1	GENERAL ARCHITECTURE.....	9
2.2	POWER SUPPLIES AND REGULATORS.....	10
2.3	DATA COMMUNICATION MODEL & DEFINITIONS.....	10
2.4	FREQUENCY REFERENCE AND PHASE LOCKED LOOP:.....	11
2.5	RECEIVER SECTION:.....	11
3	HOST INTERFACE DEFINITION.....	13
3.1	PINS ASSIGNMENT.....	13
4	TECHNICAL DATA AND SPECIFICATIONS.....	14
	CATTRON SUPPORT.....	15

86942TRX module meets Part 90 of the FCC rules and regulations. Compliance with the labeling requirements, FCC notices is required. In order to comply with FCC Certification requirements, the Original Equipment Manufacturer (OEM) must fulfill the following requirements.

1. The system integrator must place an exterior label on the outside of the final product housing the 8694D2TRX Module. The figure below shows the contents that must be included in this label.
2. 86942TRX modules may only be used with the antennas that have been tested and approved for use with the module.

LABELING REQUIREMENTS

The OEM must make sure that FCC labeling requirements are met. This includes a clearly visible exterior label on the outside of the final product housing that displays the contents shown in below.

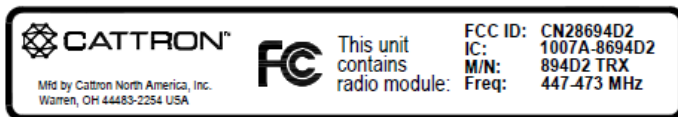

WARNING: The 8694D2TRX modules have been tested by the FCC for use with other products without further certification (as per FCC Section 2.1091). Changes or modifications to this device not expressly approved by Cattron-Theimeg could void the user’s authority to operate the equipment.

NOTICE: OEM’s must verify the final end product complies with unintentional radiators (FCC Section 15.107 and 15.109) before providing a declaration of conformity for their final product to Part 15 of the FCC Rules.

NOTICE: The 86942TRX modules have been certified for mobile and fixed radio applications. If the module will be used for portable applications, the device must undergo SAR testing.

RF Exposure WARNING: This equipment complies with FCC radiation exposure limits set forth for an uncontrolled environment. This equipment should be installed and operated with minimum distance 20 cm between the radiator and your body. This transmitter must not be co-located or operating in conjunction with any other antenna or transmitter.

NOTICE: The preceding statement must be included as a CAUTION statement in OEM product manuals in order to alert users of FCC RF Exposure compliance.

8694D2TRX is designed for use in countless wireless applications requiring long range communications with low energy consumption. To ensure that the final product complies with all of the regulatory requirements for the Modular Grant the following integration instructions should be followed. 8694D2TRX is limited to OEM installation ONLY. The OEM integrator is responsible for ensuring that the end-user has no manual instructions to remove or install the module.

FCC Part 15.105(b) Warning Statement

NOTE: This equipment has been tested and found to comply with the limits for a Class B digital device, pursuant to part 15 of the FCC Rules. These limits are designed to provide reasonable protection against harmful interference in a residential installation. This equipment generates, uses and can radiate radio frequency energy and, if not installed and used in accordance with the instructions, may cause harmful interference to radio communications. However, there is no guarantee that interference will not occur in a particular installation. If this equipment does cause harmful interference to radio or television reception, which can be determined by turning the equipment off and on, the user is encouraged to try to correct the interference by one or more of the following measures:

- Reorient or relocate the receiving antenna.
- Increase the separation between the equipment and receiver.
- Connect the equipment into an outlet on a circuit different from that to which the receiver is connected.
- Consult the dealer or an experienced radio/TV technician for help.

IC RSS-GEN, Sec 7.1.2 Warning Statement- (Required for Transmitters)

ENGLISH:

Under Industry Canada regulations, this radio transmitter may only operate using an antenna of a type and maximum (or lesser) gain approved for the transmitter by Industry Canada. To reduce potential radio interference to other users, the antenna type and its gain should be so chosen that the equivalent isotropically radiated power (e.i.r.p.) is not more than that necessary for successful communication.

FRENCH:

Conformément à la réglementation d'Industrie Canada, le présent émetteur radio peut fonctionner avec une antenne d'un type et d'un gain maximal (ou inférieur) approuvé pour l'émetteur par Industrie Canada. Dans le but de réduire les risques de brouillage radioélectrique à l'intention des autres utilisateurs, il faut choisir le type d'antenne et son gain de sorte que la puissance isotrope rayonnée équivalente (p.i.r.e.) ne dépasse pas l'intensité nécessaire à l'établissement d'une communication satisfaisante.

**IC RSS-GEN, Sec 7.1.2 Warning Statement-
(Required for Transmitters w/ detachable antennas)**

<p>ENGLISH:</p> <p>This radio transmitter (IC: 1007A-8694D2, Model Number: 8694D2TRX) has been approved by Industry Canada to operate with the antenna types listed below with the maximum permissible gain and required antenna impedance for each antenna type indicated. Antenna types not included in this list, having a gain greater than the maximum gain indicated for that type, are strictly prohibited for use with this device.</p>
<p>FRENCH:</p> <p>Le présent émetteur radio (IC:1007A-8694D2, Numéro de modèle: 8694D2TRX) a été approuvé par Industrie Canada pour fonctionner avec les types d'antennes énumérés ci-dessous ayant un gain admissible maximal et l'impédance requise pour chaque type d'antenne. Les types d'antennes non inclus dans cette liste, ou dont le gain est supérieur au gain maximal indiqué, sont strictement interdits pour l'exploitation de l'émetteur.</p>
<p>IC RSS-102</p>
<p>ENGLISH:</p> <p>The equipment using the radio transmitter (IC: 1007A-8694D2, Model Number: 8694D2TRX) should be installed and operated with a minimum distance of 24cm between the radiator and any part of your body.</p>
<p>FRENCH:</p> <p>L'équipement utilisant l'émetteur radio (IC:1007A-8694D2, Numéro de modèle: 8694D2TRX) doit être installé et utilisé avec une distance minimale de 24 centimètres entre le radiateur et n'importe quelle partie de votre corps.</p>
<p>IC RSS-GEN</p>
<p>ENGLISH:</p> <p>This device complies with Industry Canada's license-exempt RSSs. Operation is subject to the following two conditions: (1) This device may not cause interference; and (2) This device must accept any interference, including interference that may cause undesired operation of the device.</p>
<p>FRENCH:</p> <p>Le présent appareil est conforme aux CNR d'Industrie Canada applicables aux appareils radio exempts de licence. L'exploitation est autorisée aux deux conditions suivantes : (1) l'appareil ne doit pas produire de brouillage, et (2) l'utilisateur de l'appareil doit accepter tout brouillage radioélectrique subi, même si le brouillage est susceptible d'en compromettre le fonctionnement.</p>

Only the following authorized antennas may be used with the equipment:

Only the antenna gain less than 4.15dBi may be used with the equipment.

2PCA-7839-A001, 500hm, Gain:-0dBi

2PCA-8694-Dxxx Radio Module
9S02-8694-D001

2PCA-8339-X301, 50Ohm, Gain:-5.0dBi
PRT-0000430 (EXD-450-BN), 50Ohm, Gain:-0dBi
2PCA-8430-X001, 50Ohm, Gain: 2.0dBi
½ wave Omni antenna (SUB-4302), 4.15dBi

1 INTRODUCTION

1.1 PURPOSE

A new family of RF module is being developed by Cattron. This family includes high performance radios covering several RF bands used world-wide for remote control applications. They are built around a common architecture, and present a uniform host interface definition. The host interface is used for data communication and radio configuration.

1.2 SCOPE

This document describes the host interface signal definitions, timings, operation mode, available functionalities, and provide details about its integration to Unity products. This document does not cover RF specifications or power supply specifications.

1.3 APPLICABILITY

This description applies to all 2PCA-8694-Dxxx.

1.4 ACRONYMS, ABBREVIATIONS

Acronyms

CTS - Clear to Send. RS-232 control signal
RTS - Request to Send. RS-232 control signal
DTR - Data Terminal Ready. RS-232 control signal
DSR - Data Set Ready. RS-232 control signal
TX - Transmit data. RS-232 data signal
RX - Receive data. RS-232 data signal
LED- Light emitting diode
UART- Universal Asynchronous Receiver Transmitter

Abbreviations

MIPS - Million Instructions Per Second
SPI – Serial peripheral interface
USB- Universal serial bus
uP - Micro Processor
P.C. Printed Circuit
PC (Personal) Computer – Desktop or Laptop

2 FEATURES SUMMARY

2.1 GENERAL ARCHITECTURE

The Cattron Transceiver consists of a UHF Receiver as well as a UHF Transmitter section that is controlled by a digital subsection providing and processing protocol and control functions for the overall radio requirements.

The figure below shows a high-level block diagram of the radio.

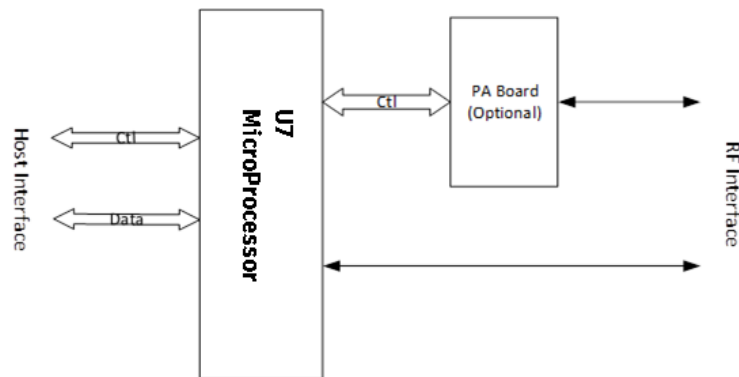

Figure 2.1 – LRM2 high-level block diagram

The U7 is located between the host interface and the RF interface, providing decoupling between host and RF interface. The microprocess has sufficient buffer space for one telegram.

As shown later, telegram processing is defined to minimize delays, so to provide a “transparent-like” behavior.

The transceiver is intended to be powered using an externally provided 12VDC supply.

The overall current consumption @ 12VDC in RX mode is about 110mA.

The Transmit section was designed to provide a nominal output power of +27dBm into a 50 ohm load.

The overall current consumption for TX is an additional 450mA, resulting in a total current during TX of about 560mA.

The RF section is contained in a shielded enclosure that has openings for four 50ohm SMB connections:

1. ANT1 --- RX input 1
2. ANT2 --- RX input 2
3. ANT3 --- RX input 3
4. TX OUT

In addition to these there are openings for visual observation of the PLL Lock status, as well as two alignment points, one adjusting the 2nd RX LO frequency and adjusting the RX Quadrature detector.

There is no need to trim the TX and the RX front end sections,

The following sections will contain a detailed description of the different circuit blocks pertaining to the transceiver.

2.2 POWER SUPPLIES AND REGULATORS

A nominal external 12VDC is supplied to the assembly using P101 pin 7 (positive) and pin 10 (negative).

This input is directly fed to U113 (LT1961EMS8-5#PBF) and to U5004 (KA7809). These two LDOs could accept 12VDC+/-15% .

The +5VDC output of U113 is used to supply the digital section as well as the RX DATA buffer and shaping amplifiers and the modulation active filter chain, this +5V supply voltage feeds also a 2.7V voltage regulator to supply the ADC reference voltage for the CPU (U6001 – ADP160AUJZ-2.7).

The +9VDC output is used to feed the RF RX regulator MIC5216-5.0 (U4) which provides +5V to the synthesizer and RX chain.

The +9V output is also used to supply regulator U52002 (KA7805) which is powering the TX Driver and PA stages.

2.3 DATA COMMUNICATION MODEL & DEFINITIONS

The communication model defines some of the terminology used in the radio.

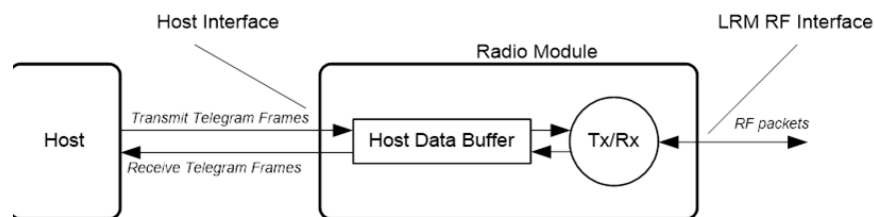

Figure 2.2 - Data communication model

- The Radio Module is used to communicate telegrams between **hosts**. In Unity context, hosts are OCU and MCU CPU boards. The radio has two interfaces: a **Host Interface** and a **RF Interface**.
- Transmit and Received Telegrams are relayed through the radio **Host Data Buffer**. This buffer is capable to hold only one telegram at a time. The purpose of this buffer is to relax host timings requirements, and to allow decoupling between Host Interface and RF Interface data rates.

- Telegrams sent/received on the Host Interface and RF interface are encapsulated into **frames** to improve synchronization.
- The radio does not perform any processing on the telegrams content; it controls only the frames overhead.

2.4 Frequency Reference and Phase Locked Loop:

The overall RF system frequency reference is provided by a 14.4 MHz VCTCXO (designator Y4).

The synthesizer uses an external VCO (designator U6) that is tunable from 425 to 475 MHz.

The nominal RF output level of the VCO is nominally between +2 and +6 dBm into 50 ohms.

The RF output of the VCO is subsequently split using resistive dividers into:

1. RF Sample input for the PLL
2. 1st RX Mixer LO input
3. TX signal input to the TX Amplifier chain.

2.5 Receiver Section:

The RF input to the Receive section is provide using one of the existing ANT1, 2, 3 input, these are selected using signals provided by the Microcontroller (designator U5).

The received signal is the routed to a UHF SAW filter FL1 that has a width of about 20MHz and is centered in one of the designated RX bands:

Low Band – 406 to 425 MHz

Mid Band – 425 to 447 MHz

High Band – 447 to 475 MHz

These filters are installed depending on the RX Band variants that are being used.

The Local Oscillator input is supplied by an output of the splitter mentioned above referring to the VCO.

The 21.4MHz mixer signal output is filtered using a crystal Filter (designator Y1), the BW of this filter is selected depending on the product variant built (either a narrow or a wide band version).

After filtering the 21.4 MHz signal is routed to an FM IC that performs an additional frequency down-conversion to 455kHz and provides a second mixer and 2nd LO oscillator using and externally supplied crystal (designator Y2).

2PCA-8694-Dxxx Radio Module
9S02-8694-D001

The FM IC SA605 (designator U2) additionally provides limiting IF gain and quadrature detection as well as having outputs for RSSI monitoring besides the demodulated signal.

The second IF Filtering is provided using two 455kHz Ceramic Filters 455FU (455DU) (designators FL3 and FL4).

3 HOST INTERFACE DEFINITION

3.1 PINS ASSIGNMENT

Description	IO	Signal	P101	P102	Signal	IO	Description
Range limit		RNGLMT	1	1	Chassis		Shielding
RS232 Rx Data	I	RXD	2	2	TXD	O	RS232 TX data
RS232 TX data	O	TXD	3	3	RXD	I	RS232 Rx Data
Programe enable	I	PROGn	4	4	RTSD	O	RS232 request to send data
Receiver common ground		GND	5	5	CTSD	I	RS232 clear to send data
		NC	6	6	+12V		
		+12V	7	7	GND		
Clock	I	/CLK	8	8	AUX/RDATA	I	Auxillary line
Reset	I	/STB	9				
		GND	10				

Table 3.1 – Host Interface pins assignment

4 TECHNICAL DATA AND SPECIFICATIONS

Model	2PCA-8694-X201
Dimensions (W x L x H)	90 x 120 x 20 mm
Weight	130g
Operating Temperature	-30° C – 80° C
Storage Temperature	-45° C – 85° C
Power Supply Input	12V 0.3A (max)
Specified frequency range	447-473MHz
Channel spacing	12.5KHz
Data rate / Modulation	4.8kbps / GFSK 2.4KHz deviation
RX Sensitivity	-114dBm +/-2dB
RX Saturation	>-10dBm
TX conducted power	480mW
TX harmonic	-50dBc
RoHS	Compliant

2PCA-8694-Dxxx Radio Module
9S02-8694-D001



CATTRON SUPPORT

For Remote & Communication Control Systems Support, Parts & Repair, or Technical Support, visit us online at:
<https://www.cattron.com/contact/>

Due to continuous product improvement, specifications may change without notice.

This product is manufactured at the following locations:

Cattron North America Inc. 655 N River Rd NW, Suite A, Warren, OH 44483