



F² Engineering Testing Laboratory

FCC Certification Test Report

Prepared on behalf of:

Mitsumi Electric Co., Ltd.
8-8-2 Kokuryo-cho, Chofu-shi
Tokyo 182, Japan

for

Keyboard
Model: KFK-ESY**

Equipment Received	December 28, 1998
Test Completed	December 30, 1998
Report Date	December 30, 1998

FCC ID: CMYKFK8065

I hereby state that: The measurements shown in this application were made in accordance with the procedures indicated and the energy emitted by this equipment was found to be within the limits applicable. I assume full responsibility for the accuracy and completeness of these measurements.

I further state that: On the basis of the measurements made, the equipment tested is capable of operation in accordance with the requirements of Part 15 of the FCC Rules under normal use and maintenance.

I confirm that all the information in this application that has been transferred is correct.

Certified by: Francis Chau
Francis Chau, Senior EMC Engineer

This report shall not be duplicated except in full without the written approval of F² Engineering

Total Pages	14
-------------	----

10880 Moxley Rd., Damascus, MD 20872 301-253-4500 fax 301-253-5179

December 30, 1998

Dear Sirs:

The following Application for Certification is being submitted on behalf of Mitsumi Electric Co., Ltd. with the Exhibits listed below for the following:

FCC ID: CMYKFK8065

List of Exhibits

Exhibit A	<i>Engineering Statement</i>
Exhibit B	<i>Measurement Instrumentation List</i>
Exhibit C	<i>EUT Information</i>
Exhibit D	<i>Block Diagram</i>
Exhibit E	<i>EUT Configuration</i>
Exhibit F	<i>Conducted Test Data</i>
Exhibit G	<i>Radiated Test Data</i>
Exhibit H	<i>Modification Letter</i>



F² Engineering Testing Laboratory

Exhibit A

ENGINEERING STATEMENT

This report has been prepared on behalf of Mitsumi Electric Co., Ltd. to support the attached Application for Equipment Authorization. The test and application are submitted for a Class B Computing Device under Part 15 of the FCC Rules and Regulations. The test results found in this test report relate only to the items tested.

EQUIPMENT UNDER TEST: *Keyboard*

FCC ID: CMYKFK8065

APPLICABLE RULES: 2.1033; 15.101-109

MEASUREMENT LOCATION: F² Engineering in Damascus, MD. Site description and attenuation data are on file with the FCC's Sampling and Measurement Branch at the FCC Laboratory in Columbia, MD.

MEASUREMENT PROCEDURE: All measurements were performed according to the 1992 version of ANSI C63.4. A list of the measurement equipment can be found in Exhibit B.

A2LA STATEMENT: This laboratory is accredited by the American Association for Laboratory Accreditation (A2LA) and the results shown in this test report have been determined in accordance with the laboratory's terms of accreditation unless stated otherwise in the report.

A2LA CERTIFICATE NUMBER: 793.01



F² Engineering Testing Laboratory

Engineering Statement, continued

UNCERTAINTY BUDGET:

- Radiated Emission
Combined Uncertainty (+ or -) 2.24 dB
Expanded Uncertainty (+ or -) 4.48 dB
- Conducted Emission
Combined Uncertainty (+ or -) 1.13 dB
Expanded Uncertainty (+ or -) 2.26 dB

Exhibit B

LIST OF MEASUREMENT INSTRUMENTATION:

- **Rohde and Schwarz ESMI Receiver**
- **Compliance Design Biconical Antenna Set**
- **Compliance Design Non-Magnetic Tripod**
- **Compliance Design Antenna Mount Adaptor**
- **Compliance Design Dual Phase L.I.S.N., Qty. 2**
- **Compliance Design 4 Meter Mast**
- **Compliance Design Amplifier P2000**
- **Antenna Research Associates Horn Antenna**

Exhibit C

Equipment Under Test Information and Data

TEST ITEM CONDITION: The equipment to be tested was received in good condition.

TESTING ALGORITHM: A basic program was written to send a continuous stream of "H's" to the video port and I/O ports of the computer. The system was tested in all modes of operation and clock speeds. Worst case emissions are recorded in the data tables.

CONDUCTED EMISSION TESTING: The EUT was placed on a .8 meter high, 1 X 1.5 meter non-conductive table. Power was provided to the EUT through a LISN bonded to a 3 X 2 meter ground plane. The LISN and peripherals were supplied power through a filtered AC power source. The output of the LISN was connected to the input of the receiver and emissions in the range 150kHz to 30 MHz were measured. The measurements were recorded using the quasi-peak values, and the resolution bandwidth during testing was 9kHz. All data for conducted emissions are found in Exhibit F.

RADIATED EMISSION TESTING: The EUT was tested at a distance of 3 meters. The emissions were maximized by rotating the table and raising/lowering the antenna mounted on a 4-meter mast. Cable and peripheral positions were also varied to produce maximum emissions. Both horizontal and vertical field components were measured. The output of the antenna was connected, through a pre-amplifier, to the input of the receiver and emissions were measured in the range 30MHz to 2GHz. The values under 1GHz with a resolution bandwidth of 120KHz are quasi-peak reading made at 3 meters. The measurements above 1GHz with a resolution bandwidth of 1MHz are peak reading at a distance of 3 meters. All data for radiated emissions are found in Exhibit G.

CALCULATION OF DATA: RADIATED EMISSIONS - The antenna factors(including cable losses) of the biconical antennas used, and the pre-amplifier gain, are input into the memory of the receiver. The receiver then corrects the reading for amplitude automatically. The field strength reading can then be taken directly from the receiver and compared to the FCC limits in dBuV/m. The following equation is used to convert to uV/m:

$$E_{uV/m} = \text{antilog}(E_{dBuV/m} / 20)$$

Equipment Under Test Information, continued

SAMPLE OF FIELD STRENGTH CALCULATION:

$$E_a = V_a + AF + A_e + (-AG)$$

Where E_a = Field Strength(dBuV/m)
 $V_a = 20 \times \log_{10}$ (Measure RF voltage, uV)
 A_e = Cable Loss Factor, dB
 AG = Amplifier Gain, dB
 AF = Antenna Factor dB(m-1)

i.e. If the reading is 57.0 dBuV, the antenna factor 8.0 dB, cable loss factor 1.0 dB and Amplifier gain is 25.0 dB, so the field strength will be:

$$\begin{aligned} E_a(\text{dBuV/m}) &= 57 + 8 + 1 + (-25) \\ &= 41 \text{ dBuV/m} \end{aligned}$$

or

$$\begin{aligned} E_a(\text{uV/m}) &= 10^{(41/20)} \\ &= 112.20 \text{ uV/m} \end{aligned}$$

Exhibit D

B l o c k D i a g r a m

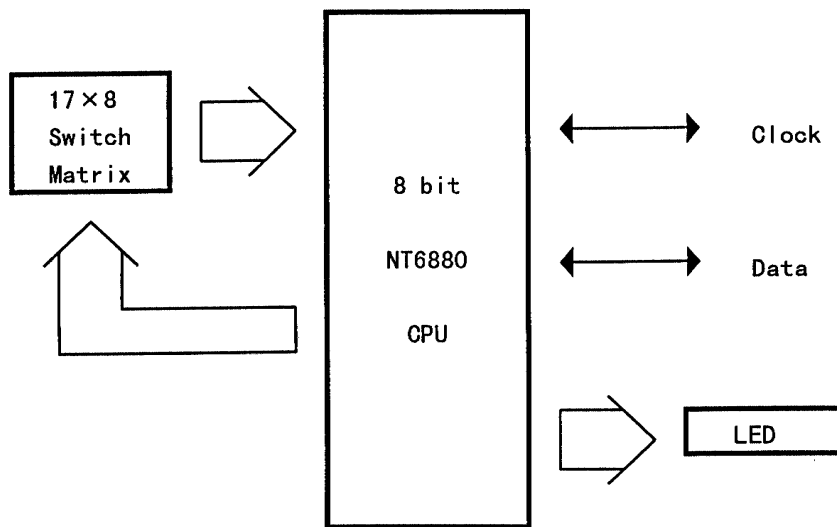

Exhibit E**EUT Configuration and Cables****EUT:**

Device	Manufacturer	Model #	FCC ID
Keyboard	Mitsumi Electric Co., Ltd.	KFK-E**SY	CMYKFK8065

Peripherals:

Device	Manufacturer	Model # / Serial #	FCC ID
Computer	Compaq	XL5120	CNT75MD16
Monitor	Philips Electronics	CM2099D201	A3KM043
Printer	Matsushita Electronic	KX-2-23	ACJ5Z6KX-P2023
Modem	US Robotics	0459	FCC DoC

Remarks:

Cable: All one meter or greater in length – bundled according to **ANSI C63.4 – 1992**

Monitor: Power - shielded
Data - shielded with plastic hoods

Printer: Power - unshielded supplied with printer
Data - shielded with plastic hoods

Modem: Power - unshielded supplied with modem
Data - shielded with metal hoods

Computer: Power - shielded

Internal Device:

Device	Manufacturer	Model #	FCC ID
PCI VGA Card	Compaq	X033	CNT75MXZ21

Exhibit F

CONDUCTED DATA

Conducted Test Line: Phase

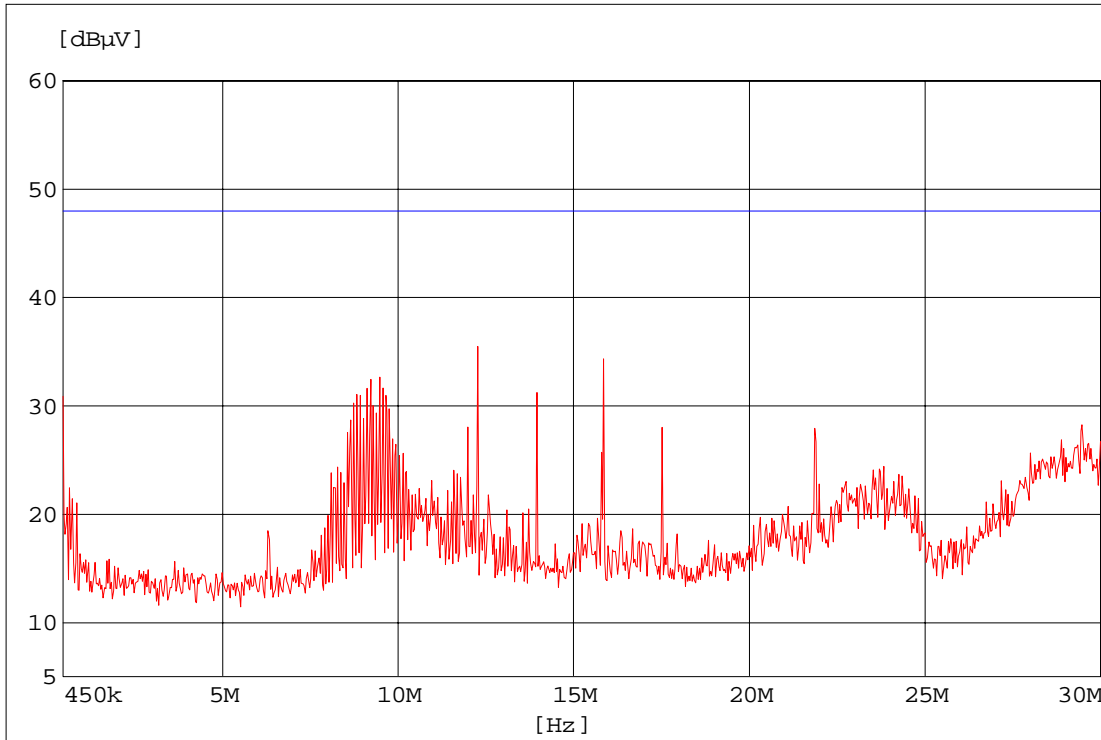

Frequency MHz	Level dBµV
0.450000	30.85
8.822500	31.03
9.216500	32.43
9.479167	32.65
9.741833	29.72
12.270000	35.46
13.944500	31.21
15.848833	34.33

Conducted Test Line: Neutral

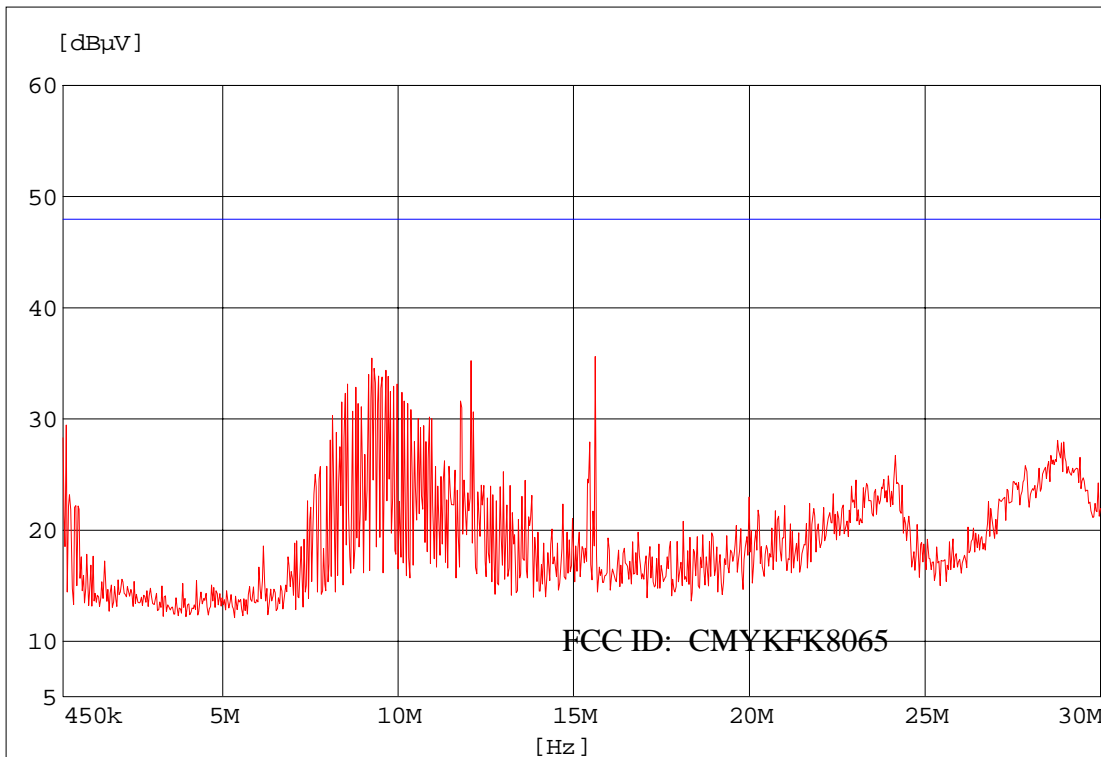

Frequency MHz	Level dBµV
8.559833	33.14
8.789667	32.83
9.249333	35.49
9.315000	34.54
9.709000	33.80
10.103000	32.36
12.073000	35.26
15.619000	35.60

FCC ID: CMYKFK8065

Exhibit G

RADIATED TEST DATA

Frequency (MHz)	Reading (dBuV)		Emission(uV)		FCC Limits	
	Horizontal	Vertical	Horizontal	Vertical	(dBuV/m)	(uV/m)
138.23	28.97	27.85	28.09	24.69	43.50	149.62
158.93	29.72	30.03	30.62	31.73	43.50	149.62
166.22	34.10	32.00	50.70	39.81	43.50	149.62
215.03	32.62	30.71	42.76	34.32	43.50	149.62
230.38	36.17	36.40	64.34	66.07	46.00	199.53
243.91	36.71	38.50	68.47	84.14	46.00	199.53
368.63	37.28	34.95	73.11	55.91	46.00	199.53
416.60	36.30	37.14	65.31	71.94	46.00	199.53
481.09	37.60	38.61	75.86	85.21	46.00	199.53

Remarks:

PASS

 FAIL

Exhibit H
Modifications

EUT COMPLIES
WITHOUT MODIFICATIONS BY F² ENGINEERING TESTING LAB.

