

FCC TEST REPORT

FOR

Embed International Pty Ltd

Insert Card Reader Color Glo

Model No.: ICR-001

Prepared for : Embed International Pty Ltd
Address : 2 Neil Street, Osborne Park, Perth, Western Australia 6017 Australia

Prepared by : Shenzhen LCS Compliance Testing Laboratory Ltd.
Address : 1/F., Xingyuan Industrial Park, Tongda Road, Bao'an Avenue, Bao'an District, Shenzhen, Guangdong, China

Date of receipt of test sample : October 29, 2014
Number of tested samples : 1
Serial number : Prototype
Date of Test : October 29, 2014 - November 13, 2014
Date of Report : November 13, 2014

FCC TEST REPORT
FCC CFR 47 PART 15 C(15.225): 2013

Report Reference No. : **LCS1410290934E**
Date of Issue : November 13, 2014

Testing Laboratory Name..... : **Shenzhen LCS Compliance Testing Laboratory Ltd.**
Address : 1/F., Xingyuan Industrial Park, Tongda Road, Bao'an Avenue,
Bao'an District, Shenzhen, Guangdong, China
Testing Location/ Procedure..... : Full application of Harmonised standards
Partial application of Harmonised standards
Other standard testing method

Applicant's Name : **Embed International Pty Ltd**
Address : 2 Neil Street, Osborne Park, Perth, Western Australia 6017
Australia

Test Specification
Standard : FCC CFR 47 PART 15 C(15.225): 2013
Test Report Form No..... : LCSEMC-1.0
TRF Originator : Shenzhen LCS Compliance Testing Laboratory Ltd.
Master TRF..... : Dated 2011-03

Shenzhen LCS Compliance Testing Laboratory Ltd. All rights reserved.
This publication may be reproduced in whole or in part for non-commercial purposes as long as the Shenzhen LCS Compliance Testing Laboratory Ltd. is acknowledged as copyright owner and source of the material. Shenzhen LCS Compliance Testing Laboratory Ltd. takes no responsibility for and will not assume liability for damages resulting from the reader's interpretation of the reproduced material due to its placement and context.

Test Item Description. : **Insert Card Reader Color Glo**
Trade Mark : N/A
Model/ Type reference..... : ICR-001
Ratings : DC12V,1A
Result : **Positive**

Compiled by:

Supervised by:

Approved by:

Jacky Li/ File administrators

Danny Huang/ Technique principal

Gavin Liang/ Manager

FCC -- TEST REPORT

Test Report No. : LCS1410290934E	<u>November 13, 2014</u> Date of issue
---	---

Type / Model..... : ICR-001 EUT..... : Insert Card Reader Color Glo
Applicant..... : Embed International Pty Ltd Address..... : 2 Neil Street, Osborne Park, Perth, Western Australia 6017 Australia Telephone..... : / Fax..... : /
Manufacturer..... : Embed International Pty Ltd Address..... : 2 Neil Street, Osborne Park, Perth, Western Australia 6017 Australia Telephone..... : / Fax..... : /
Factory..... : Embed International Pty Ltd Address..... : 2 Neil Street, Osborne Park, Perth, Western Australia 6017 Australia Telephone..... : / Fax..... : /

Test Result	Positive
--------------------	-----------------

The test report merely corresponds to the test sample.
It is not permitted to copy extracts of these test result without the written permission of the test laboratory.

TABLE OF CONTENTS

Description	Page
1. GENERAL INFORMATION	5
1.1 Description of Device (EUT)	5
1.2 Support equipment List	5
1.3 External I/O Cable	5
1.4 Description of Test Facility	5
1.5 Statement of The Measurement Uncertainty	6
1.6 Measurement Uncertainty	6
1.7 Description Of Test Modes	6
2. TEST METHODOLOGY	7
2.1 EUT Configuration	7
2.2 EUT Exercise	7
2.3 General Test Procedures	7
3. SYSTEM TEST CONFIGURATION	8
3.1 Justification	8
3.2 EUT Exercise Software	8
3.3 Special Accessories	8
3.4 Block Diagram/Schematics	8
3.5 Equipment Modifications	8
3.6 Test Setup	8
4.FREQUENCY TOLERANCE	9
5. RADIATED MEASUREMENT	11
5.1 Test Equipment	11
5.2 Block Diagram of Test Setup	11
5.3 Radiated Emission Limit	12
5.4 Instruments Setting	13
5.5 Test Procedures	14
5.6 Results for Radiated Emissions	14
6. 20DB BANDWIDTH	17
6.1 Standard Applicable	17
6.2 Test Equipment	17
6.3 Block Diagram of Test Setup	17
6.4 Test Procedure	17
6.5 Test result	18
7. LINE CONDUCTED EMISSIONS	19
7.1 Standard Applicable	19
7.2 Test Equipment	19
7.3 Block Diagram of Test Setup	19
7.4 Test Results	19
8. ANTENNA REQUIREMENT	21
8.1 Standard Applicable	21
8.2 Antenna Connected Construction	21
9. MANUFACTURER/ APPROVAL HOLDER DECLARATION	22

1. GENERAL INFORMATION

1.1 Description of Device (EUT)

EUT	Insert Card Reader Color Glo
Model No.	ICR-001
Channel frequency	13.56MHz
Channel Number	1
Modulation Type	ASK
Antenna Gain	PCB antenna, 33.0dBi(Max.)
Input Voltage	: DC12V,1A

1.2 Support equipment List

Manufacturer	Description	Model	Serial Number	Certificate
--	--	--	--	--

1.3 External I/O Cable

I/O Port Description	Quantity	Cable
--	--	--

1.4 Description of Test Facility

Site Description

EMC Lab.

: Accredited by CNAS, June 04, 2010
 The Certificate Registration Number. is L4595.
 Accredited by FCC, July 14, 2011
 The Certificate Registration Number. is 899208.
 Accredited by Industry Canada, May. 02, 2011
 The Certificate Registration Number. is 9642A-1
 Accredited by VCCI, Japan January 30, 2012
 The Certificate Registration Number. is C-4260 and R-3804
 Accredited by ESMD, April 24, 2012
 The Certificate Registration Number. is ARCB0108.
 Accredited by UL, June 11, 2012
 The Certificate Registration Number. is 100571-492.
 Accredited by TUV, November 21, 2012
 The Certificate Registration Number. is SCN1081
 Accredited by Intertek, December 21, 2012
 The Certificate Registration Number. is 2011-RTL-L1-50.

1.5 Statement of The Measurement Uncertainty

The data and results referenced in this document are true and accurate. The reader is cautioned that there may be errors within the calibration limits of the equipment and facilities. The measurement uncertainty was calculated for all measurements listed in this test report acc. To CISPR 16 – 4 “Specification for radio disturbance and immunity measuring apparatus and methods – Part 4: Uncertainty in EMC Measurements” and is documented in the LCS quality system acc. To DIN EN ISO/IEC 17025. Furthermore, component and process variability of devices similar to that tested may result in additional deviation. The manufacturer has the sole responsibility of continued compliance of the device.

1.6 Measurement Uncertainty

Test Item	Frequency Range	Uncertainty	Note
Radiation Uncertainty	9KHz~30MHz	$\pm 3.10\text{dB}$	(1)
	30MHz~200MHz	$\pm 2.96\text{dB}$	(1)
	200MHz~1000MHz	$\pm 3.10\text{dB}$	(1)
	1GHz~26.5GHz	$\pm 3.80\text{dB}$	(1)
	26.5GHz~40GHz	$\pm 3.90\text{dB}$	(1)
Conduction Uncertainty	150kHz~30MHz	$\pm 1.63\text{dB}$	(1)
Power disturbance	30MHz~300MHz	$\pm 1.60\text{dB}$	(1)

(1). This uncertainty represents an expanded uncertainty expressed at approximately the 95% confidence level using a coverage factor of $k=2$.

1.7 Description Of Test Modes

Transmitting mode: Keep the EUT in transmitting mode with worst case data rate.

The sample was placed 0.8m above the ground plane of 3m chamber*. Measurements in both horizontal and vertical polarities were performed. During the test, each emission was maximized by: having the EUT continuously working, investigated all operating modes, rotated about all 3 axis (X, Y & Z) and considered typical configuration to obtain worst position, manipulating interconnecting cables, rotating the turntable, varying antenna height from 1m to 4m in both horizontal and vertical polarizations. The emissions worst-case are shown in Test Results of the following pages.

2. TEST METHODOLOGY

The tests documented in this report were performed in accordance with ANSI C63.10-2009, RSS-210, FCC CFR PART 15C 15.207, 15.209, 15.215, 15.225.

2.1 EUT Configuration

The EUT configuration for testing is installed on RF field strength measurement to meet the Commissions requirement and operating in a manner that intends to maximize its emission characteristics in a continuous normal application.

2.2 EUT Exercise

The EUT was operated in the engineering mode to fix the TX frequency that was for the purpose of the measurements.

According to its specifications, the EUT must comply with the requirements of the Section 15.207, 15.209, 15.215, 15.225 under the FCC Rules Part 15 Subpart C and RSS-210.

2.3 General Test Procedures

2.3.1 Conducted Emissions

The EUT is placed on the turntable, which is 0.8 m above ground plane. According to the requirements in Section 13.1.4.1 of ANSI C63.10-2009 Conducted emissions from the EUT measured in the frequency range between 0.15 MHz and 30MHz using Quasi-peak and average detector modes.

2.3.2 Radiated Emissions

The EUT is placed on a turn table, which is 0.8 m above ground plane. The turntable shall rotate 360 degrees to determine the position of maximum emission level. EUT is set 3m away from the receiving antenna, which varied from 1m to 4m to find out the highest emission. And also, each emission was to be maximized by changing the polarization of receiving antenna both horizontal and vertical. In order to find out the maximum emissions, exploratory radiated emission measurements were made according to the requirements in Section 13.1.4.1 of ANSI C63.10-2009

3. SYSTEM TEST CONFIGURATION

3.1 Justification

The system was configured for testing in a continuous transmit condition.

3.2 EUT Exercise Software

N/A.

3.3 Special Accessories

N/A.

3.4 Block Diagram/Schematics

Please refer to the related document.

3.5 Equipment Modifications

Shenzhen LCS Compliance Testing Laboratory Ltd. has not done any modification on the EUT.

3.6 Test Setup

Please refer to the test setup photo.

4.FREQUENCY TOLERANCE

4.1 Test Equipment

Item	Equipment	Manufacturer	Model No.	Serial No.	Last Cal.	Next Cal.
1	Spectrum Analyzer	Agilent	E4407B	MY41440292	2014-06-18	2015-06-17
2	DC Filter	MPE	23872C	N/A	2014-06-18	2015-06-17

4.2 Block Diagram of Test Setup

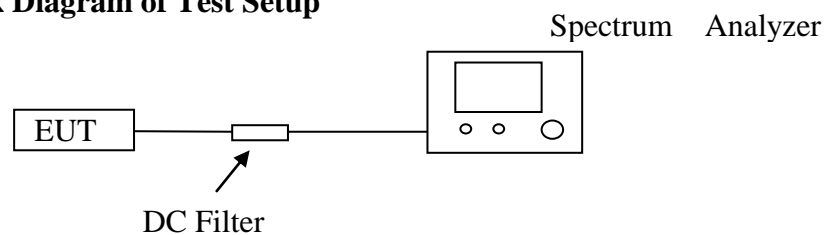

4.3 Limit

According to §15.225(e), The frequency tolerance of the carrier signal shall be maintained within +/- 0.01% of the over a temperature variation of -20 degrees to +50 degrees C at normal supply voltage, and for a variation in the primary supply voltage from 85% to 115% of the rated supply voltage at a temperature of 20 degrees C. For battery operated equipment, the equipment tests shall be performed using a new battery.

4.4 Test Procedure

The transmitter output is near to the Power Meter.

4.5 Test Results

Test Mode: Transmitting

Test condition		Frequency tolerance			
		Test result		Limit	Result
		KHz			
TEMP(20°C)	Vmin (10.2V)	+1.2	+0.0088%	+/- 0.01%	Pass
	Vnom (12.0V)	+1.1	+0.0081%	+/- 0.01%	Pass
	Vmax (13.8V)	+1.2	+0.0088%	+/- 0.01%	Pass
TEMP (60°C)	Vnom (12.0)	+1.3	+0.0096%	+/- 0.01%	Pass
TEMP (50°C)		+1.1	+0.0081%		
TEMP (40°C)		+1.1	+0.0081%		
TEMP (30°C)		+1.2	+0.0088%		
TEMP (20°C)		+1.3	+0.0096%		
TEMP (10°C)		+1.1	+0.0081%		
TEMP (0°C)		+1.2	+0.0088%		
TEMP (-10°C)		+1.0	-0.0074%		
TEMP (-20°C)		+1.3	+0.0096%		
TEMP (-30°C)		+1.1	+0.0081%		

Remark: Only record the worst result.

5. RADIATED MEASUREMENT

5.1 Test Equipment

Item	Equipment	Manufacturer	Model No.	Serial No.	Last Cal.	Next Cal.
1	3m Semi Anechoic Chamber	SIDT FRANKONIA	SAC-3M	03CH03-HY	2014-06-18	2015-06-17
2	Amplifier	SCHAFFNER	COA9231A	18667	2014-06-18	2015-06-17
3	Amplifier	Agilent	8449B	3008A02120	2014-06-16	2015-06-15
4	Amplifier	MITEQ	AMF-6F-260 400	9121372	2014-06-16	2015-06-15
5	Spectrum Analyzer	Agilent	E4407B	MY41440292	2014-06-16	2015-06-15
6	Signal analyzer	Agilent	E4448A(External mixers to 40GHz)	US44300469	2014-06-16	2015-06-15
7	Loop Antenna	R&S	HFH2-Z2	860004/001	2014-06-18	2015-06-17
8	By-log Antenna	SCHWARZBECK	VULB9163	9163-470	2014-06-10	2015-06-09
9	Double -ridged waveguide horn	SCHWARZBECK	BBHA9120D	3654-574	2014-06-10	2015-06-09
10	Horn Antenna	EMCO	3115	6741	2014-06-10	2015-06-09
11	Horn Antenna	SCHWARZBECK	BBHA9170	BBHA91701 54	2014-06-10	2015-06-09
12	RF Cable-R03m	Jye Bao	RG142	CB021	2014-06-18	2015-06-17
13	RF Cable-HIGH	SUHNER	SUCOFLEX 106	03CH03-HY	2014-06-18	2015-06-17

5.2 Block Diagram of Test Setup

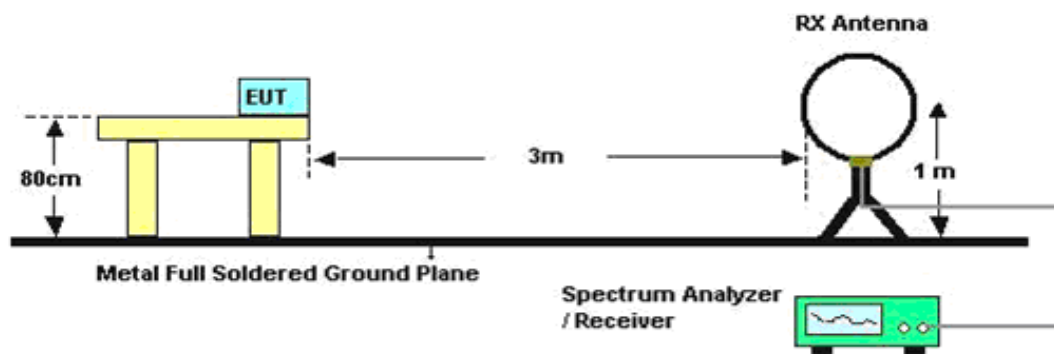

Below 30MHz

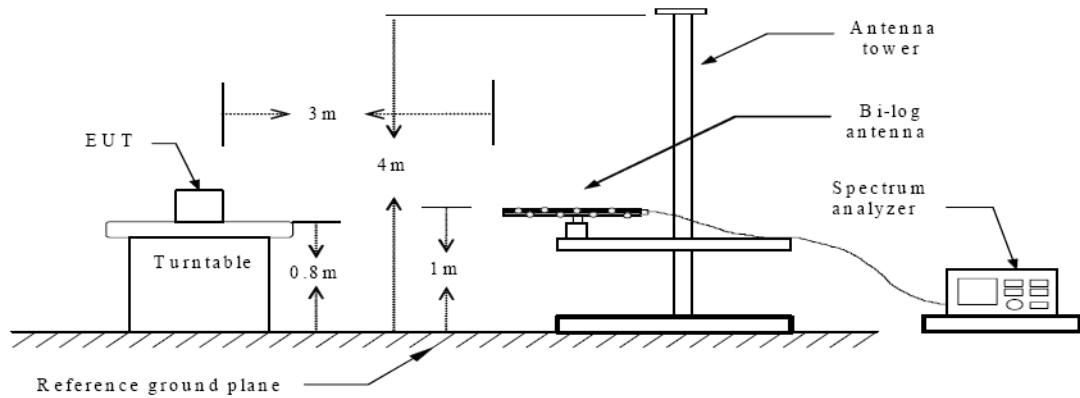

Below 1 GHz

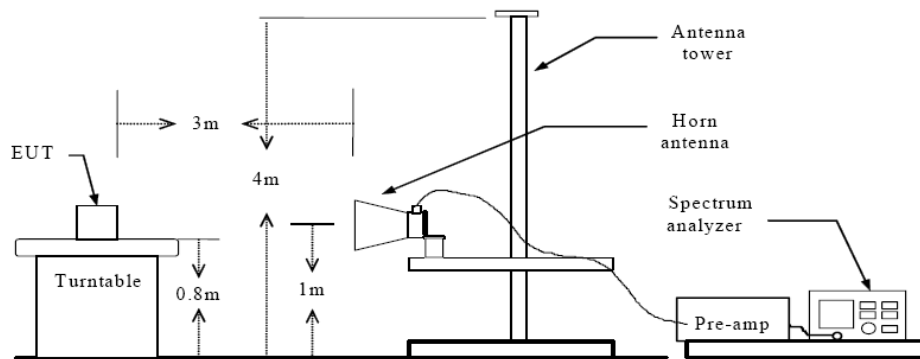

Above 1 GHz

5.3 Radiated Emission Limit

15.205 (a) Except as shown in paragraph (d) of this section, only spurious emissions are permitted in any of the frequency bands listed below:

MHz	MHz	MHz	GHz
0.090-0.110	16.42-16.423	399.9-410	4.5-5.15
\1\ 0.495-0.505	16.69475-16.69525	608-614	5.35-5.46
2.1735-2.1905	16.80425-16.80475	960-1240	7.25-7.75
4.125-4.128	25.5-25.67	1300-1427	8.025-8.5
4.17725-4.17775	37.5-38.25	1435-1626.5	9.0-9.2
4.20725-4.20775	73-74.6	1645.5-1646.5	9.3-9.5
6.215-6.218	74.8-75.2	1660-1710	10.6-12.7
6.26775-6.26825	108-121.94	1718.8-1722.2	13.25-13.4
6.31175-6.31225	123-138	2200-2300	14.47-14.5
8.291-8.294	149.9-150.05	2310-2390	15.35-16.2
8.362-8.366	156.52475-156.52525	2483.5-2500	17.7-21.4
8.37625-8.38675	156.7-156.9	2690-2900	22.01-23.12
8.41425-8.41475	162.0125-167.17	3260-3267	23.6-24.0
12.29-12.293.	167.72-173.2	3332-3339	31.2-31.8
12.51975-12.52025	240-285	3345.8-3358	36.43-36.5
12.57675-12.57725	322-335.4	3600-4400	(\2)
13.36-13.41			

\1\ Until February 1, 1999, this restricted band shall be 0.490-0.510 MHz.

\2\ Above 38.6

Part 15.205 (b) Except as provided in paragraphs (d) and (e), the field strength of emissions appearing within these frequency bands shall not exceed the limits shown in Section 15.209. At frequencies equal to or less than 1000 MHz, compliance with the limits in Section 15.209 shall be demonstrated using measurement instrumentation employing a CISPR quasi-peak detector.

Above 1000 MHz, compliance with the emission limits in Section 15.209 shall be demonstrated based on the average value of the measured emissions. The provisions in Section 15.35 apply to these measurements.

Part 15.209 (a) Except as provided elsewhere in this Subpart, the emissions from an intentional radiator shall not exceed the field strength levels specified in the following table:

Frequency (MHz)	Field strength (microvolts/meter)	Measurement distance (meters)
0.009–0.490	2400/F(kHz)	300
0.490–1.705	24000/F(kHz)	30
1.705–30.0	30	30
30–88	100**	3
88–216	150**	3
216–960	200**	3
Above 960	500	3

5.4 Instruments Setting

The following table is the setting of spectrum analyzer and receiver.

Spectrum Parameter	Setting
Attenuation	Auto
Start Frequency	1000 MHz
Stop Frequency	6000 MHz
RB / VB (Emission in restricted band)	1MHz / 1MHz for Peak, 1 MHz / 10Hz for Average
RB / VB (Emission in non-restricted band)	1MHz / 1MHz for Peak, 1 MHz / 10Hz for Average

Receiver Parameter	Setting
Attenuation	Auto
Start ~ Stop Frequency	9kHz~150kHz / RB 200Hz for QP
Start ~ Stop Frequency	150kHz~30MHz / RB 9kHz for QP
Start ~ Stop Frequency	30MHz~1000MHz / RB 100kHz for QP

5.5 Test Procedures

1. Configure the EUT according to ANSI C63.4. The EUT was placed on the top of the turntable 0.8 meter above ground. The phase center of the receiving antenna mounted on the top of a height-variable antenna tower was placed 3 meters far away from the turntable.
2. Power on the EUT and all the supporting units. The turntable was rotated by 360 degrees to determine the position of the highest radiation.
3. The height of the broadband receiving antenna was varied between one meter and four meters above ground to find the maximum emissions field strength of both horizontal and vertical polarization.
4. For each suspected emissions, the antenna tower was scan (from 1 m to 4 m) and then the turntable was rotated (from 0 degree to 360 degrees) to find the maximum reading
5. Set the test-receiver system to Peak or CISPR quasi-peak Detect Function with specified bandwidth under Maximum Hold Mode.
6. For emissions above 1GHz, use 1MHz VBW and RBW for peak reading. Then 1MHz RBW and 10Hz VBW for average reading in spectrum analyzer.
7. When the radiated emissions limits are expressed in terms of the average value of the emissions, and pulsed operation is employed, the measurement field strength shall be determined by averaging over one complete pulse train, including blanking intervals, as long as the pulse train does not exceed 0.1 seconds. As an alternative (provided the transmitter operates for longer than 0.1 seconds) or in cases where the pulse train exceeds 0.1 seconds, the measured field strength shall be determined from the average absolute voltage during a 0.1 second interval during which the field strength is at its maximum value.
8. If the emissions level of the EUT in peak mode was 3 dB lower than the average limit specified, then testing will be stopped and peak values of EUT will be reported, otherwise, the emissions which do not have 3 dB margin will be repeated one by one using the quasi-peak method for below 1GHz.
9. For testing above 1GHz, the emissions level of the EUT in peak mode was lower than average limit (that means the emissions level in peak mode also complies with the limit in average mode), then testing will be stopped and peak values of EUT will be reported, otherwise, the emissions will be measured in average mode again and reported.
10. In case the emission is lower than 30MHz, loop antenna has to be used for measurement and the recorded data should be QP measured by receiver. High – Low scan is not required in this case.

5.6 Results for Radiated Emissions

PASS.

Only record the worst test result in this report.

The test data please refer to following page:

Below 30MH

Freq. MHz	Antenna Pol.	Reading dBuV	Factor dB	Measured dBuV	Limit dBuV/m	Margin dB	Remark
0.350	H	--	--	--	65	--	--
1.000	H	--			65		--
3.57	H	36.87	11.71	48.58	69.5	-20.92	Peak
10.76	H	17.13	11.04	28.17	69.5	-41.33	Peak
13.56	H	56.34	10.86	67.20	124	-56.80	Peak
17.69	H	14.16	10.54	24.70	69.5	-44.80	Peak
25.11	H	15.74	9.60	25.34	69.5	-44.16	Peak
28.63	H	11.95	8.91	20.86	69.5	-48.64	Peak
0.350	V	--			65		--
0.860	V	--			65		--
3.60	V	37.01	11.69	48.70	69.5	-20.80	Peak
10.75	V	17.68	11.01	28.69	69.5	-40.81	Peak
13.56	V	56.55	10.86	67.41	124	-56.59	Peak
17.71	V	14.79	10.57	25.36	69.5	-44.14	Peak
25.13	V	15.88	9.59	25.47	69.5	-44.03	Peak
28.61	V	12.14	8.93	21.07	69.5	-48.43	Peak

*Note: Factor= Antenna Gain + Cable Loss – Amplifier Gain;

“--” means noise floor.

Below 1GHz

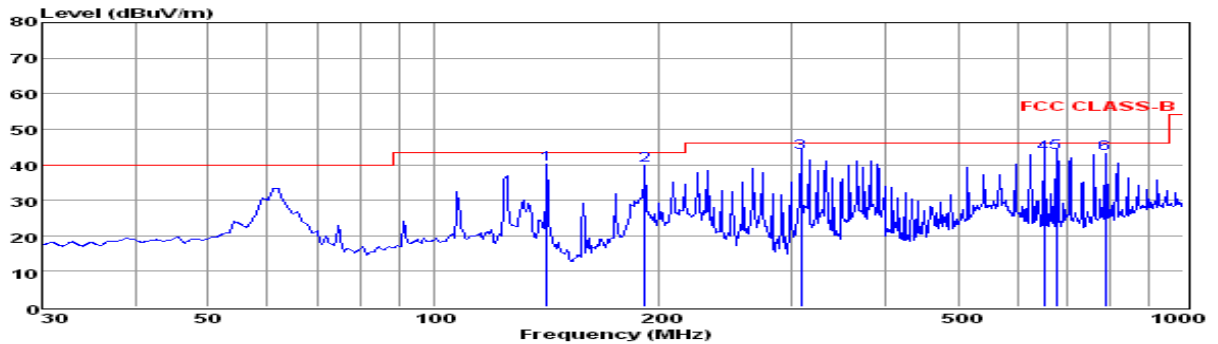

Env./Ins: 24°C/56%
 EUT: Insert card read color glo
 M/N: ICR-001
 Power Rating: DC 12V
 Test Mode: Transmitting
 Operator: Jacky
 Memo:
 pol: HORIZONTAL

	Freq MHz	Reading dBuV	CabLos dB	Antfac dB/m	Measured dBuV/m	Limit dBuV/m	Over dB	Remark
1	141.33	31.09	0.75	8.20	40.04	43.50	-3.46	QP
2	191.07	28.41	0.86	10.56	39.83	43.50	-3.67	QP
3	308.91	29.15	1.08	13.18	43.41	46.00	-2.59	QP
4	651.94	22.93	1.58	18.64	43.15	46.00	-2.85	QP
5	677.58	22.88	1.73	18.73	43.34	46.00	-2.66	QP
6	787.85	21.52	1.72	19.91	43.15	46.00	-2.85	QP

Note: 1. All readings are Quasi-peak values.
 2. Measured= Reading + Antenna Factor + Cable Loss
 3. The emission that ate 20db blow the official limit are not reported

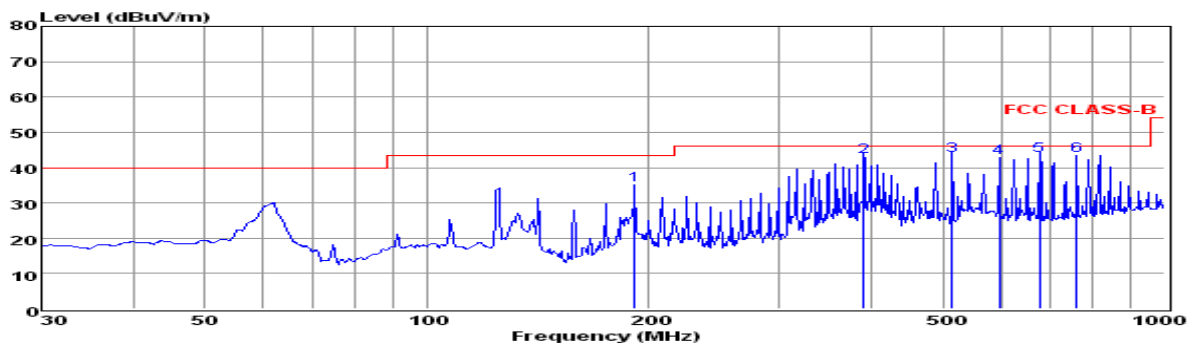

Env./Ins: 24°C/56%
 EUT: Insert card read color glo
 M/N: ICR-001
 Power Rating: DC 12V
 Test Mode: Transmitting
 Operator: Jacky
 Memo:
 pol: VERTICAL

	Freq MHz	Reading dBuV	CabLos dB	Antfac dB/m	Measured dBuV/m	Limit dBuV/m	Over dB	Remark
1	191.07	23.72	0.86	10.56	35.14	43.50	-8.36	QP
2	390.72	27.14	1.17	14.84	43.15	46.00	-2.85	QP
3	515.44	25.12	1.30	16.87	43.29	46.00	-2.71	QP
4	597.22	23.03	1.50	18.40	42.93	46.00	-3.07	QP
5	677.58	23.08	1.73	18.73	43.54	46.00	-2.46	QP
6	760.70	22.16	1.77	19.57	43.50	46.00	-2.50	QP

Note: 1. All readings are Quasi-peak values.
 2. Measured= Reading + Antenna Factor + Cable Loss
 3. The emission that ate 20db blow the official limit are not reported

Remark : The test data of transmitting mode above 1GHz is too lower than the limit, so not show in this report.

6. 20DB BANDWIDTH

6.1 Standard Applicable

According to §15.215 Intentional radiators operating under the alternative provisions to the general emission limits, as contained in §§ 15.217 through 15.257 and in Subpart E of this part, must be designed to ensure that the 20 dB bandwidth of the emission, or whatever bandwidth may otherwise be specified in the specific rule section under which the equipment operates, is contained within the frequency band designated in the rule section under which the equipment is operated.

6.2 Test Equipment

Item	Equipment	Manufacturer	Model No.	Serial No.	Last Cal.	Next Cal.
1	Spectrum Analyzer	Agilent	E4407B	MY41440292	2013-06-16	2014-06-15
2	Signal analyzer	Agilent	E4448A(External mixers to 40GHz)	US44300469	2013-06-16	2014-06-15
4	DC Filter	MPE	23872C	N/A	2013-06-18	2014-06-17

6.3 Block Diagram of Test Setup

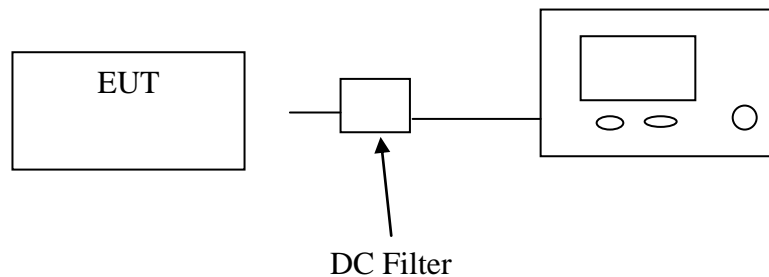

6.4 Test Procedure

The bandwidth of the fundamental frequency was measured by spectrum analyzer with 1kHz RBW and 3kHz VBW. The 20dB bandwidth is defined as the total spectrum the power of which is higher than peak power minus 20dB.

6.5 Test result

RBW/ VBW	1KHz/3KHz
SPAN	20KHz
Carrier Freq. (MHz)	20dB Bandwidth (KHz)
13.56	3.491

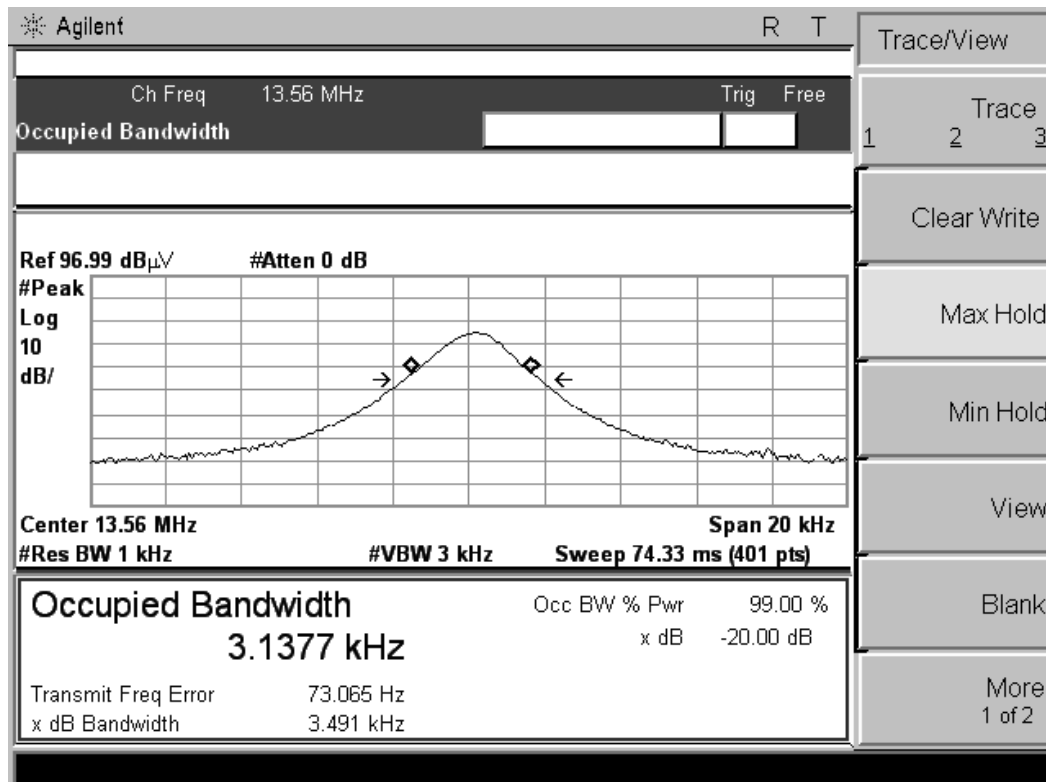

7. LINE CONDUCTED EMISSIONS

7.1 Standard Applicable

According to §15.207 (a) or RSS-GEN: For an intentional radiator which is designed to be connected to the public utility (AC) power line, the radio frequency voltage that is conducted back onto the AC power line on any frequency or frequencies within the band 150 kHz to 30 MHz shall not exceed 250 microvolt (The limit decreases linearly with the logarithm of the frequency in the range 0.15 MHz to 0.50 MHz). The limits at specific frequency range are listed as follows:

Frequency Range(MHz)	Limits (dBμV)	
	Quasi-peak	Average
0.15 to 0.50	66 to 56	56 to 46
0.50 to 5	56	46
5 to 30	60	50

7.2 Test Equipment

Item	Equipment	Manufacturer	Model No.	Serial No.	Last Cal.	Next Cal.
1	EMC Receiver	R&S	ESCS30	100174	2014-06-18	2015-06-17
2	L.I.S.N	MESS Tec	NNB-2/16Z	99079	2014-06-18	2015-06-17
3	50ΩCoaxial Switch	R&S	MP59B	M20531	2014-06-18	2015-06-17
4	Pulse Limiter	Anritsu	ESH3-Z2	100006	2014-06-18	2015-06-17
5	Voltage Probe	Rohde & Schwarz	TK9416	N/A	2014-06-18	2015-06-17

7.3 Block Diagram of Test Setup

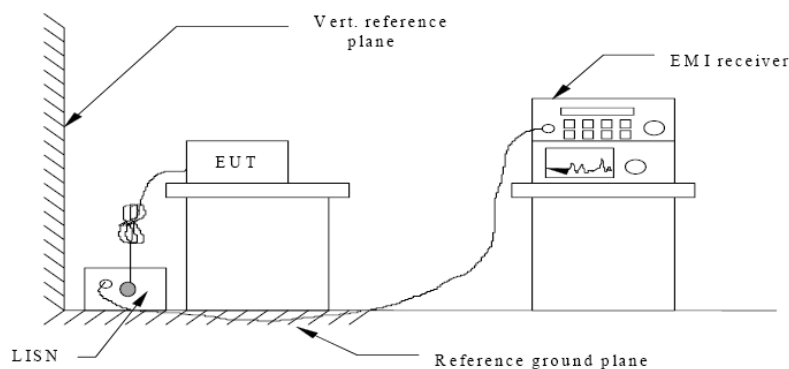

7.4 Test Results

PASS.

The test data please refer to following page.

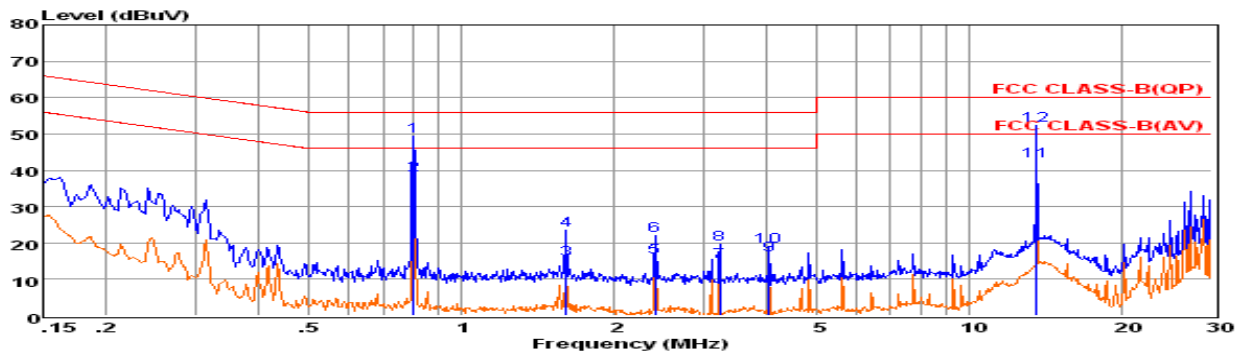

Env. Ins: 24*/56%
 EUT: Insert Card Reader Color Glo
 M/N: ICR-001
 Power Rating: DC 12V
 Test Mode: Transmitting
 Operator: Jacky
 Memo:
 Pol: LINE

Freq	Reading	LisnFac	CabLos	Atten_Fac	Measured	Limit	Over	Remark
MHz	dBuV	dB	dB	dB	dBuV	dBuV	dB	
1 0.80448	29.72	9.64	0.04	10.00	49.40	56.00	-6.60	QP
2 0.80449	19.00	9.64	0.04	10.00	38.68	46.00	-7.32	Average
3 1.61048	-4.21	9.64	0.05	10.00	15.48	46.00	-30.52	Average
4 1.61047	3.68	9.64	0.05	10.00	23.37	56.00	-32.63	QP
5 2.40898	-3.74	9.64	0.05	10.00	15.95	46.00	-30.05	Average
6 2.40897	2.24	9.64	0.05	10.00	21.93	56.00	-34.07	QP
7 3.22396	-4.96	9.65	0.06	10.00	14.75	46.00	-31.25	Average
8 3.22395	0.05	9.65	0.06	10.00	19.76	56.00	-36.24	QP
9 4.02747	-3.13	9.65	0.06	10.00	16.58	46.00	-29.42	Average
10 4.02746	-0.79	9.65	0.06	10.00	18.92	56.00	-37.08	QP
1113.55096	22.83	9.71	0.10	10.00	42.64	50.00	-7.36	Average
1213.55086	32.65	9.71	0.10	10.00	52.46	60.00	-7.54	QP

Remarks: 1. Measured = Reading + Lisn Factor +Cable Loss+Atten_Fac.
 2. The emission levels that are 20dB below the official limit are not reported.

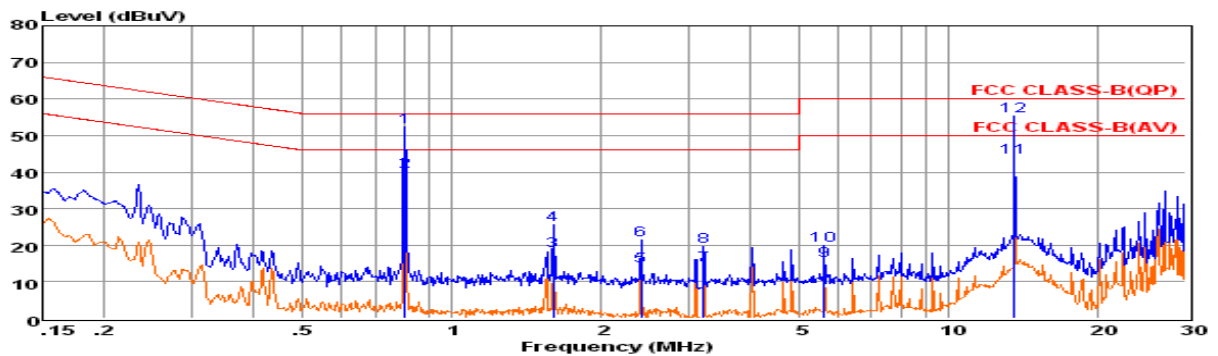

Env. Ins: 24*/56%
 EUT: Insert Card Reader Color Glo
 M/N: ICR-001
 Power Rating: DC 12V
 Test Mode: Transmitting
 Operator: Jacky
 Memo:
 Pol: NEUTRAL

Freq	Reading	LisnFac	CabLos	Atten_Fac	Measured	Limit	Over	Remark
MHz	dBuV	dB	dB	dB	dBuV	dBuV	dB	
1 0.80448	32.68	9.63	0.04	10.00	52.35	56.00	-3.65	QP
2 0.80449	20.40	9.63	0.04	10.00	40.07	46.00	-5.93	Average
3 1.60197	-1.23	9.63	0.05	10.00	18.45	46.00	-27.55	Average
4 1.60196	5.86	9.63	0.05	10.00	25.54	56.00	-30.46	QP
5 2.40898	-5.28	9.64	0.05	10.00	14.41	46.00	-31.59	Average
6 2.40897	1.77	9.64	0.05	10.00	21.46	56.00	-34.54	QP
7 3.20692	-5.03	9.65	0.06	10.00	14.68	46.00	-31.32	Average
8 3.20691	-0.23	9.65	0.06	10.00	19.48	56.00	-36.52	QP
9 5.62346	-3.89	9.67	0.06	10.00	15.84	50.00	-34.16	Average
10 5.62336	0.19	9.67	0.06	10.00	19.92	60.00	-40.08	QP
1113.55096	24.18	9.74	0.10	10.00	44.02	50.00	-5.98	Average
1213.55086	35.36	9.74	0.10	10.00	55.20	60.00	-4.80	QP

Remarks: 1. Measured = Reading + Lisn Factor +Cable Loss+Atten_Fac.
 2. The emission levels that are 20dB below the official limit are not reported.

Note: Pre-scan all modes and recorded the worst case results in this report.

8. ANTENNA REQUIREMENT

8.1 Standard Applicable

According to antenna requirement of §15.203.

An intentional radiator shall be designed to ensure that no antenna other than that furnished by the responsible party shall be used with the device. The use of a permanently attached antenna or of an antenna that uses a unique coupling to the intentional radiator shall be considered sufficient to comply with the provisions of this Section. The manufacturer may design the unit so that a broken antenna can be re-placed by the user, but the use of a standard antenna jack or electrical connector is prohibited. This requirement does not apply to carrier current devices or to devices operated under the provisions of Sections 15.211, 15.213, 15.217, 15.219, or 15.221. Further, this requirement does not apply to intentional radiators that must be professionally installed, such as perimeter protection systems and some field disturbance sensors, or to other intentional radiators which, in accordance with Section 15.31(d), must be measured at the installation site. However, the installer shall be responsible for ensuring that the proper antenna is employed so that the limits in this Part are not exceeded.

And according to §15.247(4)(1), system operating in the 2400-2483.5MHz bands that are used exclusively for fixed, point-to-point operations may employ transmitting antennas with directional gain greater than 6dBi provided the maximum peak output power of the intentional radiator is reduced by 1 dB for every 3 dB that the directional gain of the antenna exceeds 6dBi.

8.2 Antenna Connected Construction

8.2.1. Standard Applicable

According to § 15.203 & RSS-Gen, an intentional radiator shall be designed to ensure that no antenna other than that furnished by the responsible party shall be used with the device.

8.2.2. Antenna Connector Construction

The directional gains of antenna used for transmitting is 33.0dBi, and the antenna is on PCB board and no consideration of replacement. Please see EUT photo for details.

8.2.3. Results: Compliance.

.

9. MANUFACTURER/ APPROVAL HOLDER DECLARATION

The following series model(s):

--	--	--	--
----	----	----	----

Belong to the tested device:

Product description : Insert Card Reader Color Glo

Model name : ICR-001

Remark: No additional models were tested.

-----THE END OF REPORT-----