



America

---

**Choose certainty.  
Add value.**

# Report On

Application for Grant of Equipment Authorization of the  
Japan Radio Co., Ltd.  
JMR-7282-SH Marine Radar Equipment

FCC CFR 47 Part 2 and Part 80  
RSS-Gen Issue 4, November 2014  
RSS-238 Issue 1, July 2013

Report No. SD72108813-0815

October 2015





**REPORT ON** Radio Testing of the  
Japan Radio Co., Ltd.  
Marine Radar Equipment

**TEST REPORT NUMBER** SD72108813-0815

**PREPARED FOR** Japan Radio Co., Ltd.  
1011 SW Klickitat Way, Suite 201B  
Seattle, WA 98134 U.S.A.

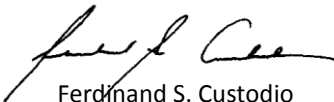
**CONTACT PERSON** Ian Bowles  
Regional Sales Manager  
(206) 465-8645  
ibowles@jrcamerica.com

**PREPARED BY**   
Ferdinand S. Custodio  
**Name**  
Authorized Signatory  
Title: EMC/Senior Wireless Test Engineer

**APPROVED BY**   
Chip R. Fleury  
**Name**  
Authorized Signatory  
Title: EMC West General Manager

**DATED** October 22, 2015



**Revision History**

SD72108813-0815 Japan Radio Co., Ltd. JMR-7282-SH Marine Radar Equipment					
DATE	OLD REVISION	NEW REVISION	REASON	PAGES AFFECTED	APPROVED BY
10/22/15	Initial Release				Chip R. Fleury



**CONTENTS**

<b>Section</b>	<b>Page No</b>
<b>1</b>	<b>REPORT SUMMARY ..... 5</b>
1.1	Introduction ..... 6
1.2	Brief Summary Of Results ..... 7
1.3	Product Information ..... 8
1.4	EUT Test Configuration ..... 13
1.5	Deviations From The Standard ..... 15
1.6	Modification Record ..... 15
1.7	Test Methodology ..... 15
1.8	Test Facility ..... 15
1.9	Sample Calculations ..... 16
<b>2</b>	<b>TEST DETAILS ..... 17</b>
2.1	RF Power Output..... 18
2.2	Frequency Stability ..... 28
2.3	Occupied Bandwidth..... 35
2.4	99% Emission Bandwidth ..... 43
2.5	Modulation Characteristics..... 50
2.6	Spurious Emissions At Antenna Port..... 52
2.7	Field Strength Of Spurious Radiation..... 59
<b>3</b>	<b>TEST EQUIPMENT USED ..... 69</b>
3.1	Test Equipment Used..... 70
3.2	Measurement Uncertainty ..... 71
<b>4</b>	<b>DIAGRAM OF TEST SETUP ..... 72</b>
4.1	Test Setup Diagram..... 73
<b>5</b>	<b>ACCREDITATION, DISCLAIMERS AND COPYRIGHT ..... 77</b>
5.1	Accreditation, Disclaimers and Copyright..... 78



## **SECTION 1**

### **REPORT SUMMARY**

Radio Testing of the  
Japan Radio Co., Ltd.  
Marine Radar Equipment



## 1.1 INTRODUCTION

The information contained in this report is intended to show verification of the Japan Radio Co., Ltd. Marine Radar Equipment to the requirements of the following standards:

- FCC CFR 47 Part 2 and Part 80
- RSS-Gen Issue 4, November 2014
- RSS-238 Issue 1, July 2013

Objective	To perform Radio Testing to determine the Equipment Under Test's (EUT's) compliance with the Test Specification, for the series of tests carried out.
Manufacturer	Japan Radio Co., Ltd.
Model Number(s)	JMR-7282-SH
FCC ID Number	CKENKE2632
IC Number	768F-NKE2632
Serial Number(s)	LC60577
Number of Samples Tested	1 system
Test Specification/Issue/Date	FCC CFR 47 Part 2 and Part 80 (October 1, 2014) RSS-Gen Issue 4, November 2014 RSS-238 Issue 1, July 2013
Start of Test	September 21, 2015
Finish of Test	September 29, 2015
Name of Engineer(s)	Ferdie Custodio
Related Document(s)	<ul style="list-style-type: none"><li>• ANSI/TIA-603-C-2004 – Land Mobile FM or PM – Communications Equipment – Measurement and Performance Standards.</li><li>• Supporting documents for EUT certification are separate exhibits.</li></ul>



1.2 **BRIEF SUMMARY OF RESULTS**

A brief summary of the tests carried out in accordance to FCC CFR 47 Part 2 and Part 80 with cross-reference to the corresponding IC RSS standard is shown below.

Section	FCC Part Sections(s)	RSS	Test Description	Result
2.1	Part 2.1046 (a) and 80.215	RSS-238 4.2	RF Power Output	Compliant
2.2	Part 2.1055 and Part 80.209 (b)	RSS-238 4.1	Frequency Stability	Compliant
-		RSS-Gen 7.2.4	Conducted Emissions	N/A
2.3	Part 2.1049 and Part 80.211(f)	RSS-238 3.2	Occupied Bandwidth	Compliant
2.4		RSS-Gen 4.6.1	99% Emission Bandwidth	Compliant
2.5	Part 2.1047 (d) and Part 80.213 (g)	RSS-238 3.2	Modulation Characteristics	Compliant
2.6	Part 2.1051 and Part 80.211 (f)	RSS-238 4.3	Spurious Emissions at Antenna Port	Compliant
2.7	2.1053 and 80.211 (f)	RSS-238 4.3	Field Strength Of Spurious Radiation	Compliant
-		RSS-Gen 6.0	Receiver Spurious Emissions	N/A <sub>1</sub>

NA Not required. EUT is not equipped to operate from the public utility AC power supply, either directly or indirectly.

NA<sub>1</sub> Not required. EUT does not fall under the classification of a Receiver by RSS-Gen.

### 1.3 PRODUCT INFORMATION

#### 1.3.1 Technical Description

The Equipment Under Test (EUT) was a Japan Radio Co., Ltd. JMR-7282-SH Marine Radar Equipment system as shown in the following photographs.



**Scanner Unit (NKE-2632-H)**



**Central Control Unit (NDC-1590/NCM-928)**





**Power Supply Unit (NBD-913)**



**Junction Box (NQE-1143)**





1.3.2 **EUT General Description**

EUT Description	Marine Radar Equipment
Model Name	JMR-7282-SH
Model Number(s)	JMR-7282-SH
Rated Voltage	120V 60Hz (Test Input Voltage)
Power Output	250 watts ±50% (335.74 watts measured)
Operating Frequency	P0N (3035 MHz) and Q0N (3065 MHz) in the 2900 MHz to 3100 MHz Band
Type of Emissions	P0N and Q0N
Primary Unit (EUT)	<input checked="" type="checkbox"/> Production <input type="checkbox"/> Pre-Production
Type of Equipment	<input checked="" type="checkbox"/> Fixed <input type="checkbox"/> Mobile <input type="checkbox"/> Portable
Emission Designator/s	5M97P0N to 35M4P0N 7M53Q0N to 8M16Q0N
Temperature Range	-25°C to 55°C (operating) -25°C to 70°C (storage)
Relative Humidity	Up to 93% (operating)

1.3.3 **System Configuration (as tested)**

JMR-7282-SH	
NKE-2632-H	Scanner Unit S/N SR00006
NWZ-207	Monitor Unit S/N ME5A130035
NDC-1590/ NCM-928	Central Control Unit S/N LC60577
	Processing Unit S/N LC60577
NBD-913	Power Supply Unit S/N 5521L050
NQE-1143/CWB-1592	Junction Box/JB Frame
NCE-5625	Keyboard Operation Unit



1.3.4 Antenna Specification

Scanner Type			NKE-1632	NKE-2632	NKE-2632-H
Size: Dimension (Height x Swing Circle)			791mm x 4000mm	720mm x 2770mm	
Mass			160kg	85kg	90kg
Type(Polarization)			Horizontal		
Antenna Directional Characteristics	Gain		27dBi	26dBi	
	Beam width	Horizontal	1.9°	2.7°	
		Vertical	25°		
	Side lobe Level	within +/-10°	below -26dB		
		outside +/-10°	below -30dB		
Revolution			Approx.24rpm	Approx.48rpm	



1.4 **EUT TEST CONFIGURATION**

1.4.1 **Test Configuration Description**

Test Configuration	Description
Default	TX Mode. Transmitting at PON (3035 MHz) and QON (3065 MHz) using operating modes SP1, MP1, MP2, LP1 or LP2.

1.4.2 **EUT Exercise Software**

None. No special test software was used during evaluation. The production software was utilized to configure the EUT in TX mode.

1.4.3 **EUT I/O cables**

Simplified Test Configuration Diagram Code (Section 1.4.5)	Cable Connection	Manufacturer Part/Reference Number	Description
A	Scanner Unit and Junction Box	2695110056	30 meters 14-core shielded composite cable.
B	Junction Box and Central Control Unit	W842	5 meters, shielded, J831 of Radar I/F Circuit Board to J4203 of Central Control Unit
C	Central Control Unit and Keyboard Operation Unit	W62	5 meters, shielded, J4201 to Trackball Operation Unit
D	Power Supply Unit and Central Control Unit	W52	5 meters, shielded, J53 of Power Supply Unit to J4204 of Central Control Unit
E	Power Supply Unit and Junction Box	W852	5 meters, unshielded, 5 conductors for AC and 48VDC
F	Central Control Unit and 19 inch Monitor Unit	W72	5 meters, shielded DVI cable, J4101 of Central Control Unit to DVI port of 19 inch Monitor Unit
G	Power Supply Unit and Central Control Unit	W54	5 meters, shielded, J52 of Power Supply Unit to J4301 of Central Control Unit
H	Power Supply Unit and 19 inch Monitor Unit	W74	5 meters, shielded, J52 of Power Supply Unit to 24VDC + Gnd ports of 19 inch Monitor Unit
I	Power Supply Unit to Power Source	-	2 meters, unshielded, 14 AWG x 3 conductors, IEC connector

1.4.4 Support Equipment for Scanner Unit (Load and directional coupler for direct measurements)

Manufacturer	Manufacturer Part/Reference Number	Description
Shimadarakougyou	42109	High power dummy load
Shimadarakougyou	R4372	30dB Directional Coupler
JRC	-	Join Scannar Unit to Waveguide I
JRC	-	Join Scannar Unit to Waveguide II
Hewlett Packard	S281A	Transducer

1.4.5 Simplified Test Configuration Diagram

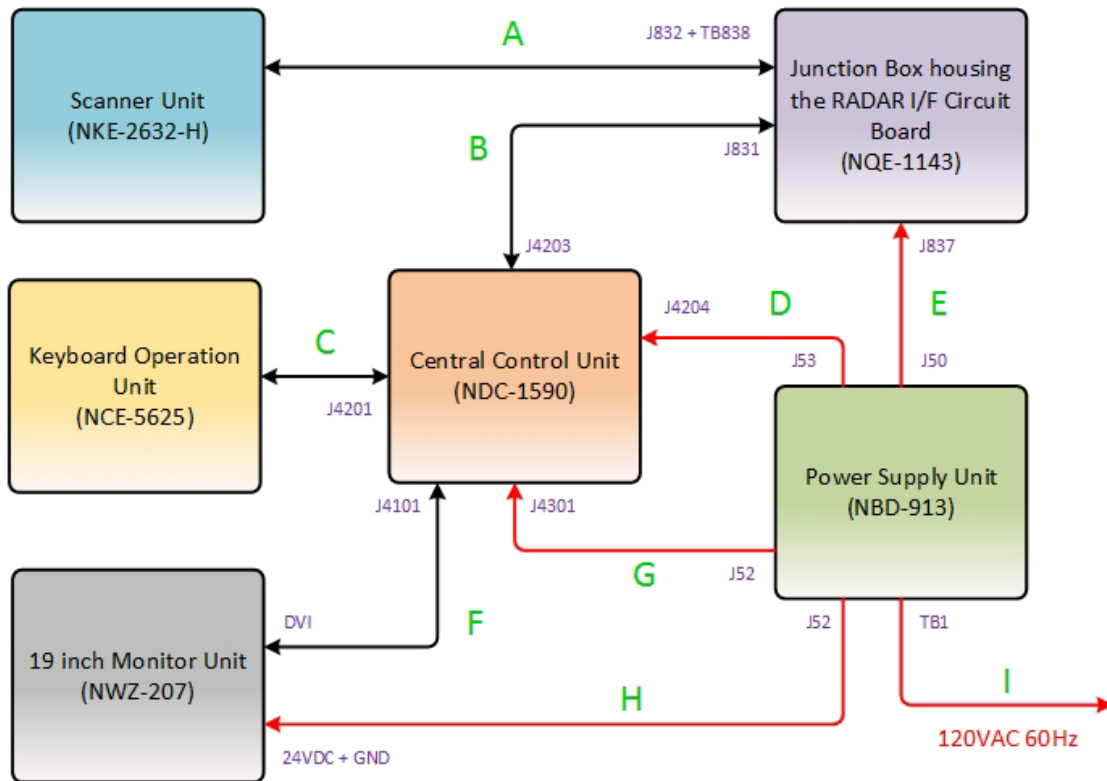



**1.5 DEVIATIONS FROM THE STANDARD**

No deviations from the applicable test standards or test plan were made during testing.

**1.6 MODIFICATION RECORD**

Description of Modification	Modification Fitted By	Date Modification Fitted
Serial Number LC60577		
N/A		

The table above details modifications made to the EUT during the test programme. The modifications incorporated during each test (if relevant) are recorded on the appropriate test pages.

**1.7 TEST METHODOLOGY**

All measurements contained in this report were conducted with ANSI C63.4-2009, American National Standard for Methods of Measurement of Radio-Noise Emissions from Low-Voltage Electrical and Electronic Equipment in the range of 9 kHz to 40 GHz.

For conducted (if applicable) and radiated emissions the equipment under test (EUT) was configured to measure its highest possible emission level. This level was based on the maximized cable configuration from exploratory testing per ANSI C63.4-2009. The test modes were adapted according to the Operating Instructions provided by the manufacturer/client.

**1.8 TEST FACILITY**

**1.8.1 FCC – Registration No.: US1146**

TUV SUD America Inc. (San Diego), is an accredited test facility with the site description report on file and has met all the requirements specified in §2.498 of the FCC rules. The acceptance letter from the FCC is maintained in our files and the Registration is US1146.

**1.8.2 Industry Canada (IC) Registration No.: 3067A**

The 10m Semi-anechoic chamber of TUV SUD America Inc. (San Diego) has been registered by Certification and Engineering Bureau of Industry Canada for radio equipment testing with Registration No. 3067A.



1.9 **SAMPLE CALCULATIONS**

1.9.1 **EUT Emission Designator**

Emission Designator = 6M00P0N  
 6M00 = 6 MHz Bandwidth Designator  
 P = Sequence of un-modulated pulses  
 0 = No modulating signal  
 N = No information transmitted

Emission Designator = 8M00Q0N  
 8M00 = 6 MHz Bandwidth Designator  
 Q = A sequence of pulses in which the carrier is angle-modulated during the period of the pulse  
 0 = No modulating signal  
 N = No information transmitted

1.9.2 **Spurious Radiated Emission (below 1GHz)**

Measuring equipment raw measurement (dBµV/m) @ 30 MHz		24.4
Correction Factor (dB)	Asset# 1066 (cable)	0.3
	Asset# 1172 (cable)	0.3
	Asset# 1016 (preamplifier)	-30.7
	Asset# 1175(cable)	0.3
	Asset# 1002 (antenna)	17.2
Reported QuasiPeak Final Measurement (dBµV/m) @ 30MHz		<b>11.8</b>

1.9.3 **Spurious Radiated Emission – Substitution Method**

Example = 84dBµV/m @ 1413 MHz (numerical sample only)

The field strength reading of 84dBµV/m @ 1413 MHz (2<sup>nd</sup> Harmonic of 706.5 MHz) is the maximized measurement when the EUT is on the turntable measured at 3 meters. The gain of the substituted antenna is 7.8dBi while the transmit cable loss is 1.0 dB (cable between signal generator and the substituted antenna). The signal generator level is adjusted until the 84dBµV/m level at the receiving end is replicated (identical test setup, i.e. same antenna, cable/s and preamp). If the adjusted signal generator level is -18dBm, then we have the following for both EIRP and ERP as required:

$$\begin{aligned}
 P_{EIRP} &= -18 \text{ dBm} + 7.8 \text{ dBi} - 1 \text{ dB} \\
 &= 11.2 \text{ dBm} \\
 P_{ERP} &= P_{EIRP} - 2.15 \text{ dB} \\
 &= 11.2 \text{ dBm} - 2.15 \text{ dB} \\
 &= 9.05 \text{ dBm}
 \end{aligned}$$





## **SECTION 2**

### **TEST DETAILS**

Radio Testing of the  
Japan Radio Co., Ltd.  
Marine Radar Equipment



## 2.1 RF POWER OUTPUT

### 2.1.1 Specification Reference

Part 2.1046 (a), Part 80.215 and RSS-238 4.2

### 2.1.2 Standard Applicable

(a) For transmitters other than single sideband, independent sideband and controlled carrier radiotelephone, power output shall be measured at the RF output terminals when the transmitter is adjusted in accordance with the tune-up procedure to give the values of current and voltage on the circuit elements specified in §2.1033(c)(8). The electrical characteristics of the radio frequency load attached to the output terminals when this test is made shall be stated.

(a) Transmitter power shown on the radio station authorization is the maximum power the licensee is authorized to use. Power is expressed in the following terms: For PON and F3N emission: Mean power.

The transmitter output power shall not exceed 60 kW and the antenna gain shall not exceed 35 dBi.

### 2.1.3 Equipment Under Test and Modification State

Serial No: LC60577 / Default Test Configuration

### 2.1.4 Date of Test/Initial of test personnel who performed the test

September 23, 2015/FSC

### 2.1.5 Test Equipment Used

The major items of test equipment used for the above tests are identified in Section 3.1.

### 2.1.6 Environmental Conditions

Test performed at TÜV SÜD America Inc. Rancho Bernardo facility.

Ambient Temperature	25.3 °C
Relative Humidity	44.3 %
ATM Pressure	99.5 kPa

### 2.1.7 Additional Observations

- This is a conducted test using a spectrum analyzer.
- For average power measurement, a 52.4 dB offset was used for the High Power Directional Coupler, external attenuator and cables correction factor.
- Pulse Rise Time was measured from the 10% to the 90% amplitude (voltage) points on the leading edge of the pulse.



- P.R.F was calculated from the measured period between pulses using the following formula:

$$PRF = \frac{1}{T_{sec}}$$

- Pulse Width was measured as the width of the pulse at 50% amplitude (voltage points).
- Duty Cycle was calculated as the product of P.R.F and Pulse Width (in seconds).
- Average Power was measured using measurement bandwidth  $\geq$  99% OBW. All other settings were set to auto.
- Peak power was calculated from the formula:

$$Peak\ Power\ (W) = \frac{Average\ Power\ (W)}{Duty\ Cycle}$$

2.1.8 Test Results

P0N						
Operating Mode	Pulse Rise Time ( $\mu$ s)	P.R.F (Hz)	Pulse Width ( $\mu$ s)	Duty Cycle (%)	Average Power (mW)	Peak Power (dBm)
SP1	0.059	2194.5	0.09855	0.0216	4.61	43.29
MP1	0.076	2194.5	0.16667	0.0366	14.12	45.87
MP2	0.076	2194.5	0.31304	0.0687	58.02	49.27
LP1	0.078	1297.1	0.60290	0.0782	174.54	53.49
LP2	0.090	643.87	1.17536	0.0757	254.01	55.26
Limit (60 kW/77.8 dBm)		Complies				
Antenna Gain (<35 dBi gain)		Complies (27 dBi EUT antenna gain – worst case)				

Q0N						
Operating Mode	Pulse Rise Time ( $\mu$ s)	P.R.F (Hz)	Pulse Width ( $\mu$ s)	Duty Cycle (%)	Average Power (mW)	Peak Power (dBm)
SP1	0.798	2198.3	4.7116	1.0358	204.29	42.95
MP1	1.578	2198.3	9.3493	2.0553	375.21	42.61
MP2	1.608	2198.3	9.2317	2.0294	430.2	43.26
LP1	1.798	1295.7	9.2517	1.1987	442.88	45.68
LP2	2.698	643.95	16.393	1.0556	852.26	49.07
Limit (60 kW/77.8 dBm)		Complies				
Antenna Gain (<35 dBi gain)		Complies (27 dBi EUT antenna gain – worst case)				

### 2.1.9 Sample Test Plot

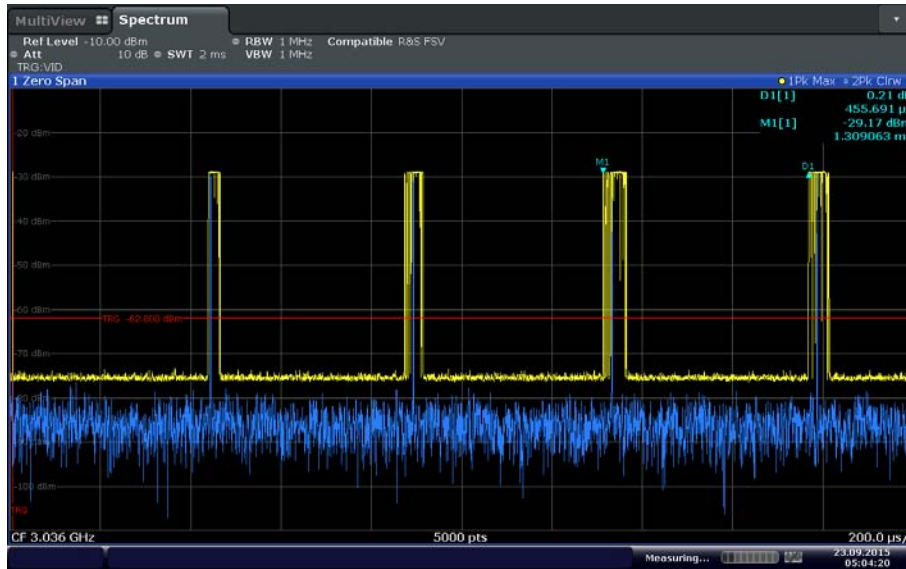

Date: 23\_SEP\_2015 05:04:21

### PON SP1 PRF

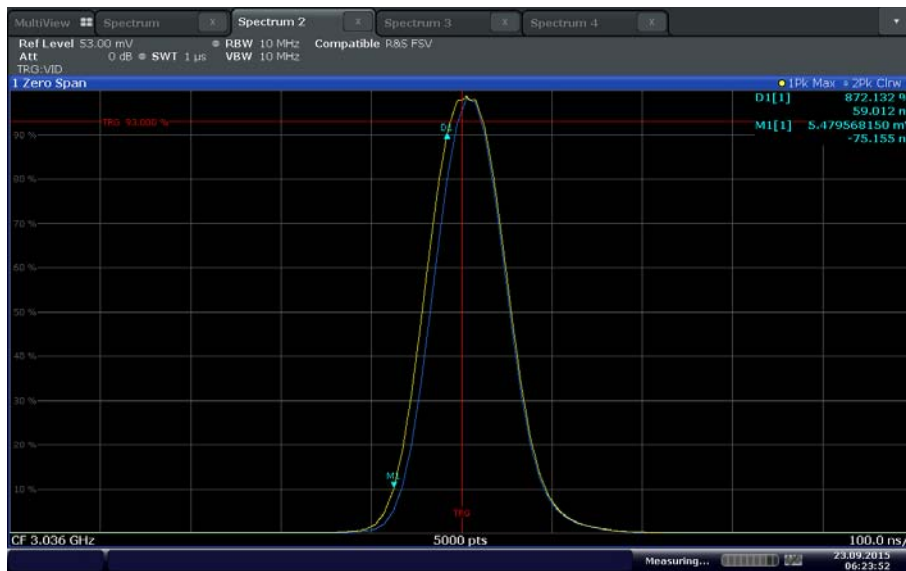

Date: 23\_SEP\_2015 06:23:52

### PON SP1 Pulse Rise Time

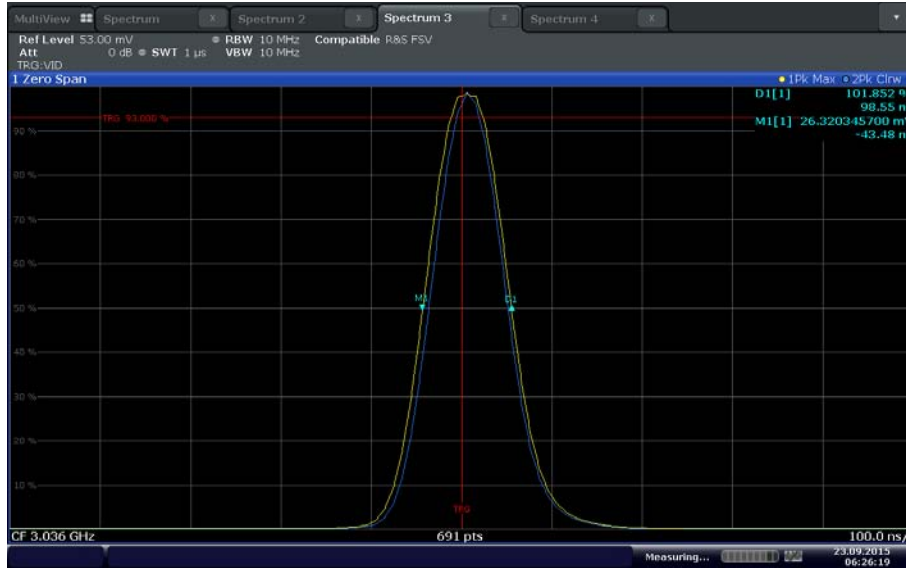

Date: 23\_SEP\_2015 06:26:19

**PON SP1 Pulse Width**

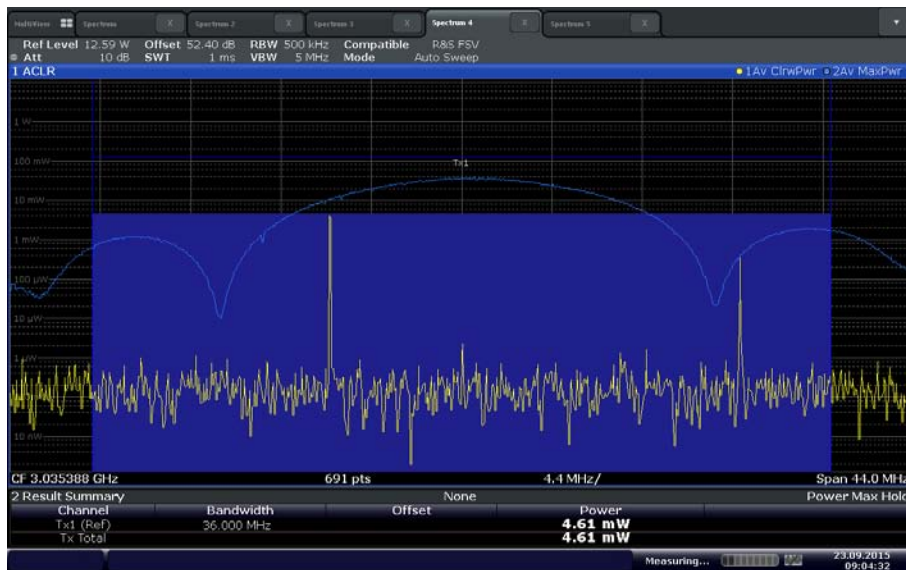

Date: 23\_SEP\_2015 09:04:32

**PON SP1 Average Power**

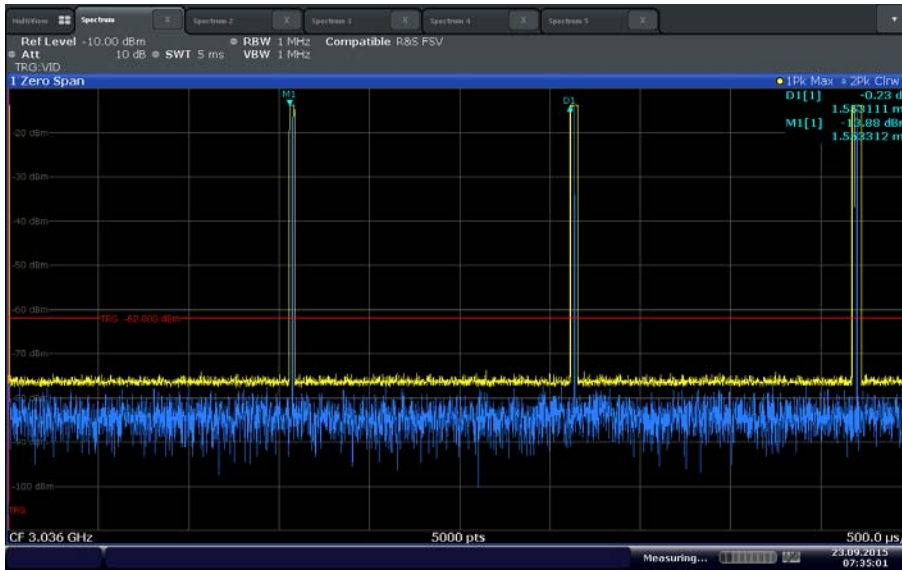

Date: 23\_SEP\_2015 07:35:01

### PON LP2 PRF

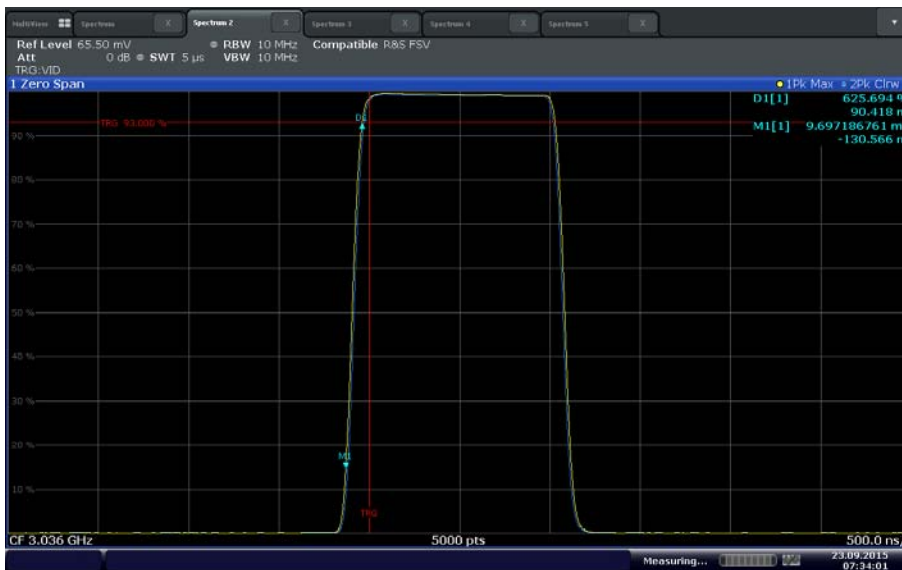

Date: 23\_SEP\_2015 07:34:01

### PON LP2 Pulse Rise Time

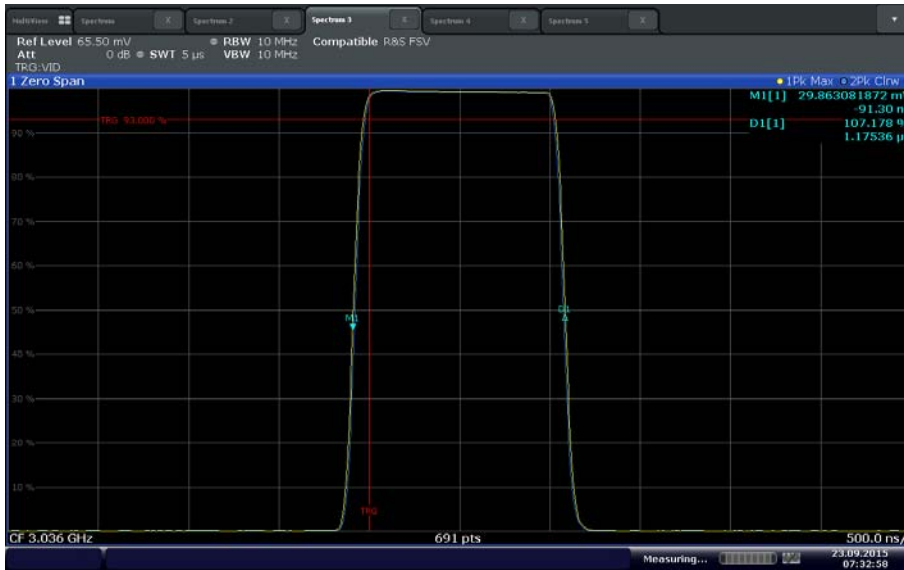

Date: 23\_SEP\_2015 07:32:58

**PON LP2 Pulse Width**

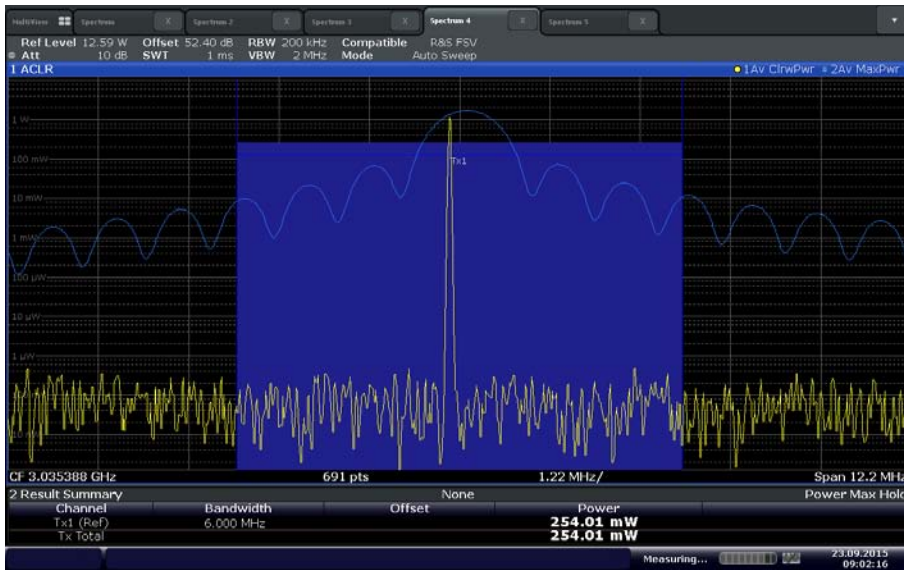

Date: 23\_SEP\_2015 09:02:16

**PON LP2 Average Power**

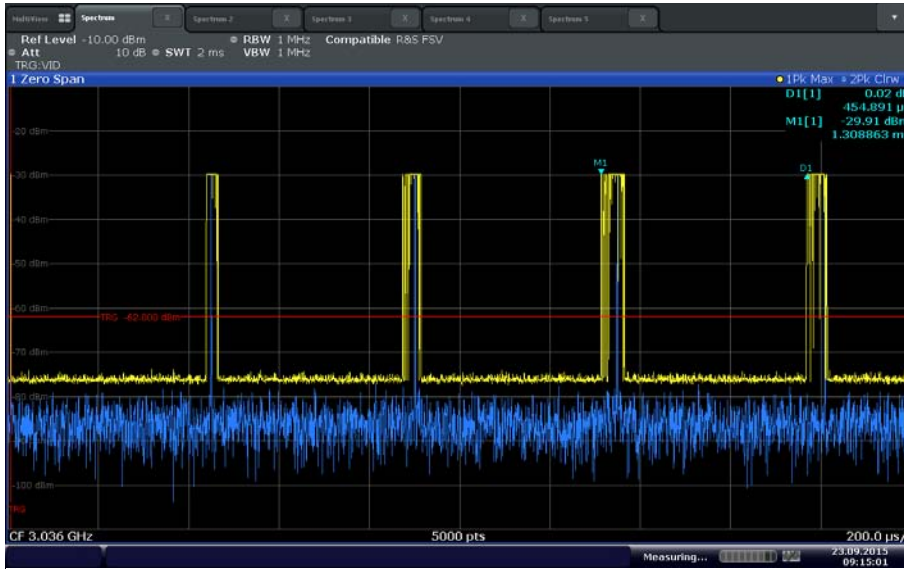

Date: 23.SEP.2015 09:15:01

### Q0N SP1 PRF

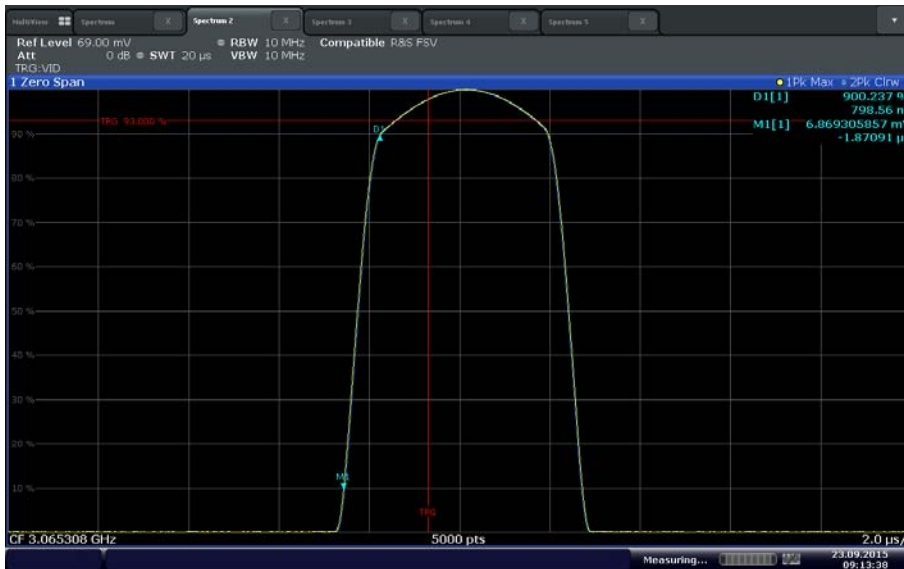

Date: 23.SEP.2015 09:13:37

### Q0N SP1 Pulse Rise Time



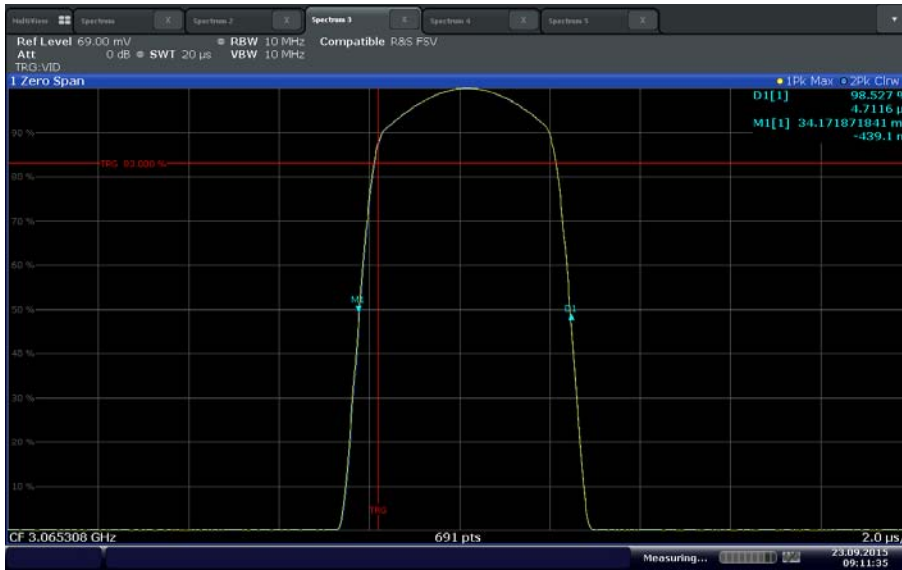

Date: 23\_SEP.2015 09:11:35

**QON SP1 Pulse Width**

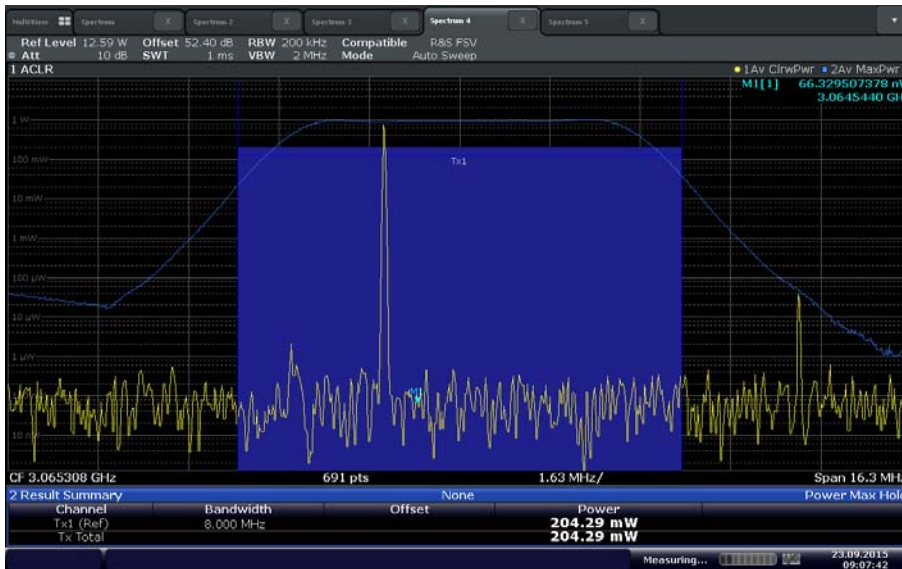

Date: 23\_SEP.2015 09:07:42

**QON SP1 Average Power**

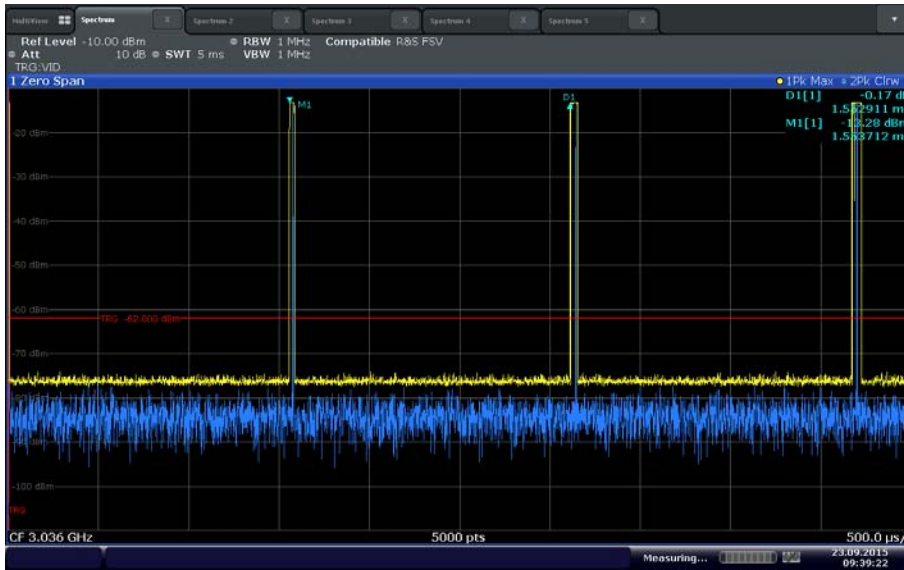

Date: 23.SEP.2015 09:39:22

**Q0N LP2 PRF**

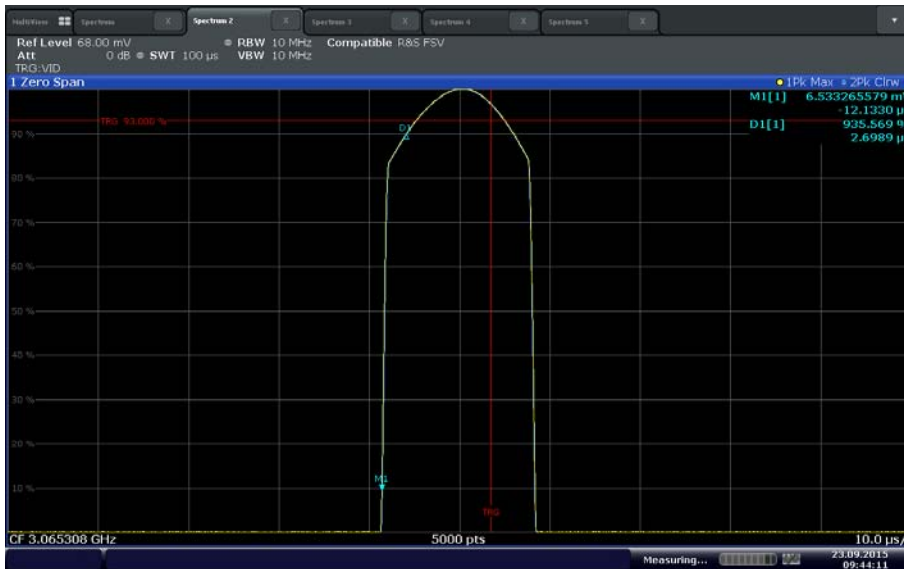

Date: 23.SEP.2015 09:44:11

**Q0N LP2 Pulse Rise Time**

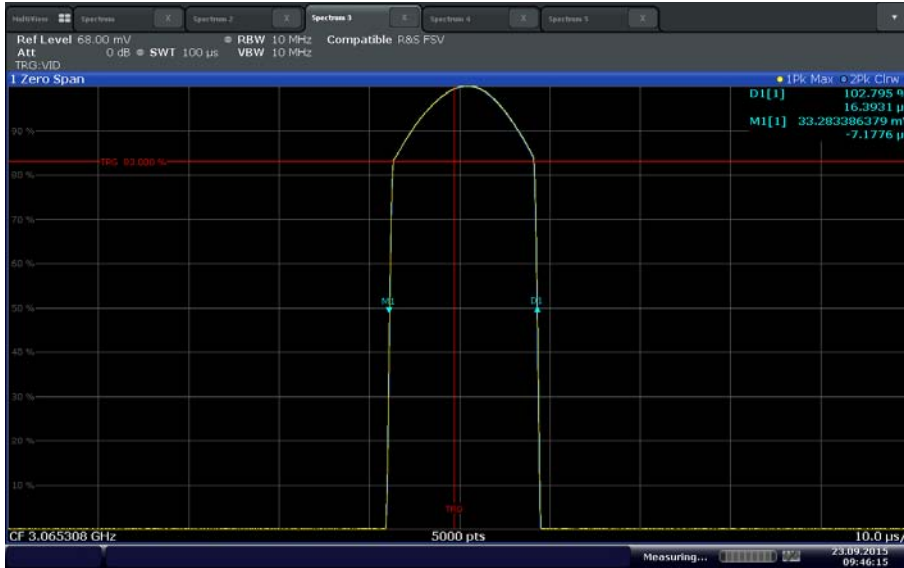

Date: 23 SEP 2015 09:46:15

**Q0N LP2 Pulse Width**

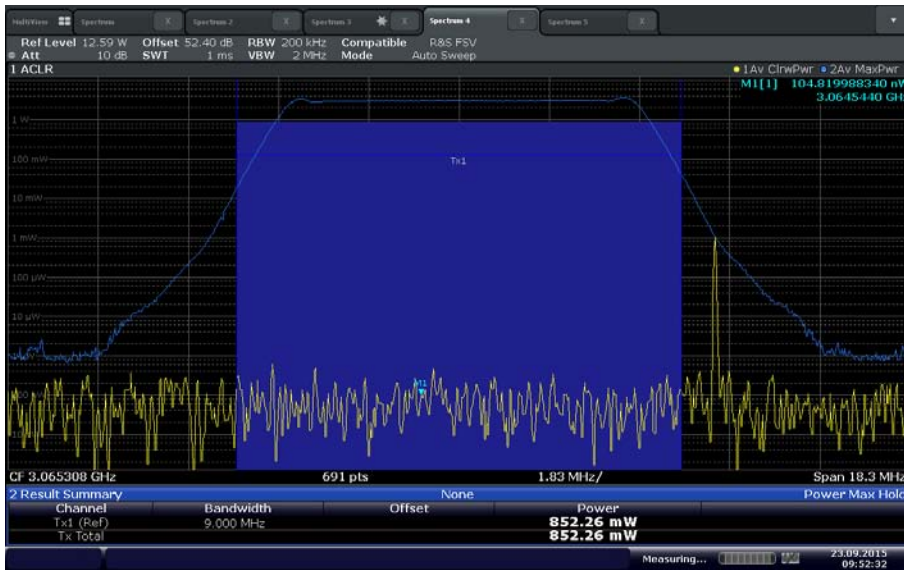

Date: 23 SEP 2015 09:52:31

**Q0N LP2 Average Power**



## 2.2 FREQUENCY STABILITY

### 2.2.1 Specification Reference

Part 2.1055, Part 80.209 (b) and RSS-238 4.1

### 2.2.2 Standard Applicable

(b) When pulse modulation is used in land and ship radar stations operating in the bands above 2.4 GHz the frequency at which maximum emission occurs must be within the authorized bandwidth and must not be closer than  $1.5/T$  MHz to the upper and lower limits of the authorized bandwidth where "T" is the pulse duration in microseconds. In the band 14.00-14.05 GHz the center frequency must not vary more than 10 MHz from 14.025 GHz.

The carrier frequency shall not depart from the reference frequency in excess of 800 ppm for equipment which operates in the band 2900-3100 MHz nor in excess of 1250 ppm for equipment which operates in the band 9225-9500 MHz.

### 2.2.3 Equipment Under Test and Modification State

Serial No: LC60577 / Default Test Configuration

### 2.2.4 Date of Test/Initial of test personnel who performed the test

September 24 and 25, 2015/FSC

### 2.2.5 Test Equipment Used

The major items of test equipment used for the above tests are identified in Section 3.1.

### 2.2.6 Environmental Conditions

Test performed at TÜV SÜD America Inc. Mira Mesa facility.

Ambient Temperature	26.7 °C
Relative Humidity	47.5 %
ATM Pressure	99.6 kPa

### 2.2.7 Additional Observations

- This is a conducted test. Only the Scanner Unit was verified in this test.
- The Temperature was reduced to -30°C and allowed to sit for 1 hour to allow the equipment and chamber temperature to stabilize. The EUT is then powered with the operating mode set to MP2. This mode represents the highest power with the least pulse duration which is considered worst case considering FCC limit factor of  $1.5/T$  where T is the pulse duration in microseconds.



- EUT operates in single channels only (P0N and Q0N). The temperature was then increased by 10°C steps and allowed to settle before taking the next set of measurements. EUT is “on” only during actual measurement time.
- Voltage variation was also performed at 85% and 115% of the nominal voltage.
- Since the Maritime Service Radar frequency band is from 2900 MHz to 3100 MHz, the FCC limit would be from 2900 MHz + 1.5/T to 3100 MHz – 1.5/T. This equates to 2900.0033 MHz to 3099.9967 MHz frequency band where the EUT can only transmit. However the EUT only transmits at 3035 MHz (P0N) and 3065 MHz (Q0N), therefore presented data will be based from the RSS-238 limit of 800 ppm.
- “n” dB down function of the spectrum analyzer was used for this test. Using the 6 dB bandwidth measurement reference points for both upper and lower edges (T1 and T2), the center frequency was calculated using the formula  $F_{\text{CENTER}} = (T1 + T2)/2$ .

2.2.8 Test Results

P0N (3035 MHz)					
Voltage (%)	Power (VAC)	Temp (°C)	Frequency (GHz)	Max. Frequency Deviation (ppm)	RSS-238 Limit (ppm)
100	120.0	-30	3.0347275645	576.92	800
100		-20	3.0347115385	592.95	
100		-10	3.0348397435	464.74	
100		0	3.0349839745	320.51	
100		+10	3.0351282050	176.28	
100		+20	3.0353044875	Reference	
100		+30	3.0354006410	-96.15	
100		+40	3.0354647435	-160.26	
100		+50	3.0355282050	-223.72	
115		138.0	+20	3.0353057896	
85	102.0	+20	3.0353049876	-0.50	
EUT stayed within 2900.0033 MHz to 3099.9967 MHz, EUT complies with FCC requirement					



Q0N (3065 MHz)					
Voltage (%)	Power (VAC)	Temp (°C)	Frequency (GHz)	Max. Frequency Deviation (ppm)	Limit (ppm)
100	120.0	-30	3.0649198720	352.56	800
100		-20	3.0649198720	352.56	
100		-10	3.0649679490	304.49	
100		0	3.0650641025	208.33	
100		+10	3.0651602565	112.18	
100		+20	3.0652724360	Reference	
100		+30	3.0653365385	-64.10	
100		+40	3.0653685900	-96.15	
100		+50	3.0653685900	-96.15	
115		138.0	+20	3.0652724360	
85	102.0	+20	3.0652727455	-0.31	
EUT stayed within 2900.0033 MHz to 3099.9967 MHz, EUT complies with FCC requirement					



2.2.9 Sample Test Plots

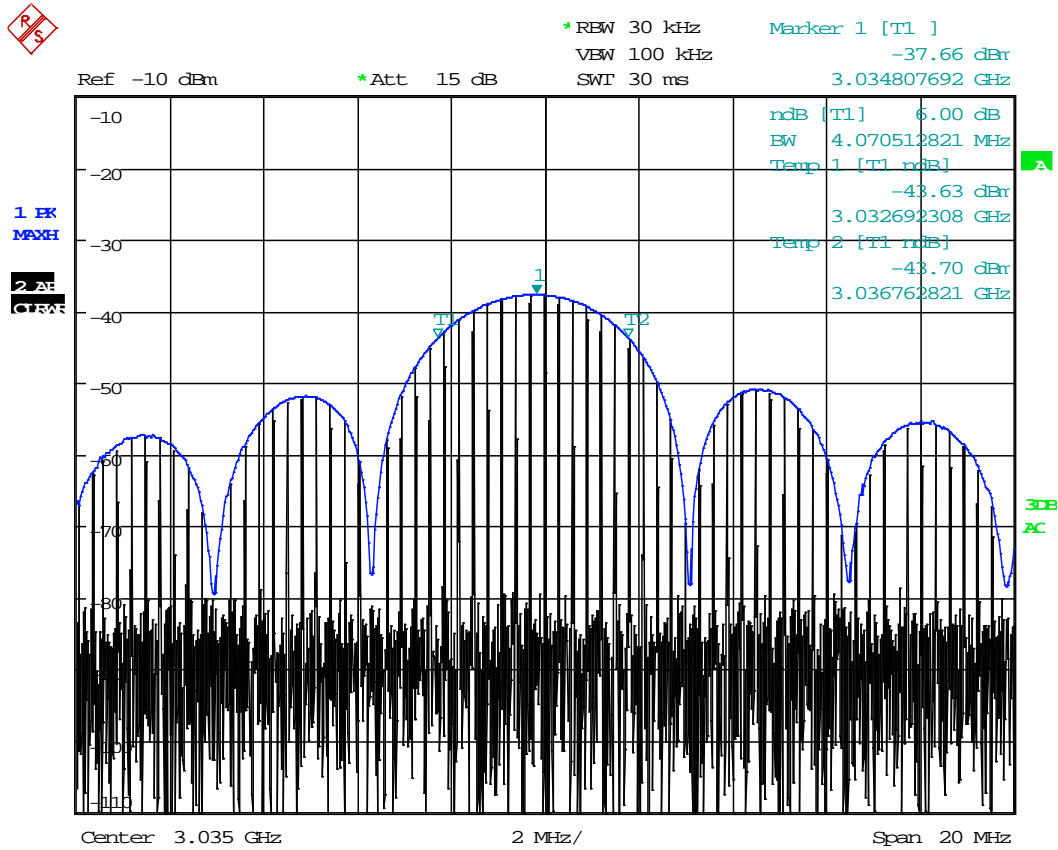

Date: 24.SEP.2015 11:14:47

**P0N @-30°C (Nominal Voltage)**

Center Frequency = (T1 + T2)/2  
 = (3.032692308 GHz + 3.036762821 GHz) / 2  
 = 6.069455129 / 2  
 = 3.0347275645 GHz

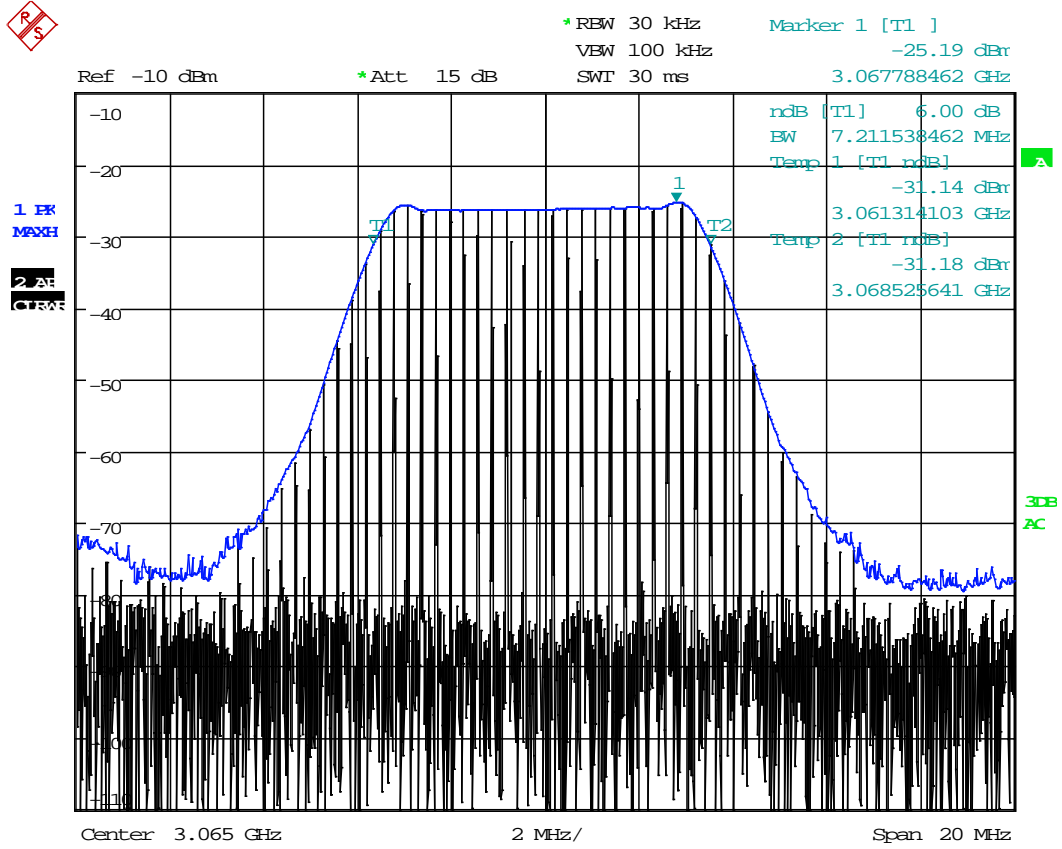

Date: 24.SEP.2015 11:13:50

**Q0N @-30°C (Nominal Voltage)**

Center Frequency =  $(T1 + T2)/2$   
 =  $(3.061314103 \text{ GHz} + 3.068525641 \text{ GHz}) / 2$   
 =  $6.129839744 / 2$   
 =  $3.064919872 \text{ GHz}$



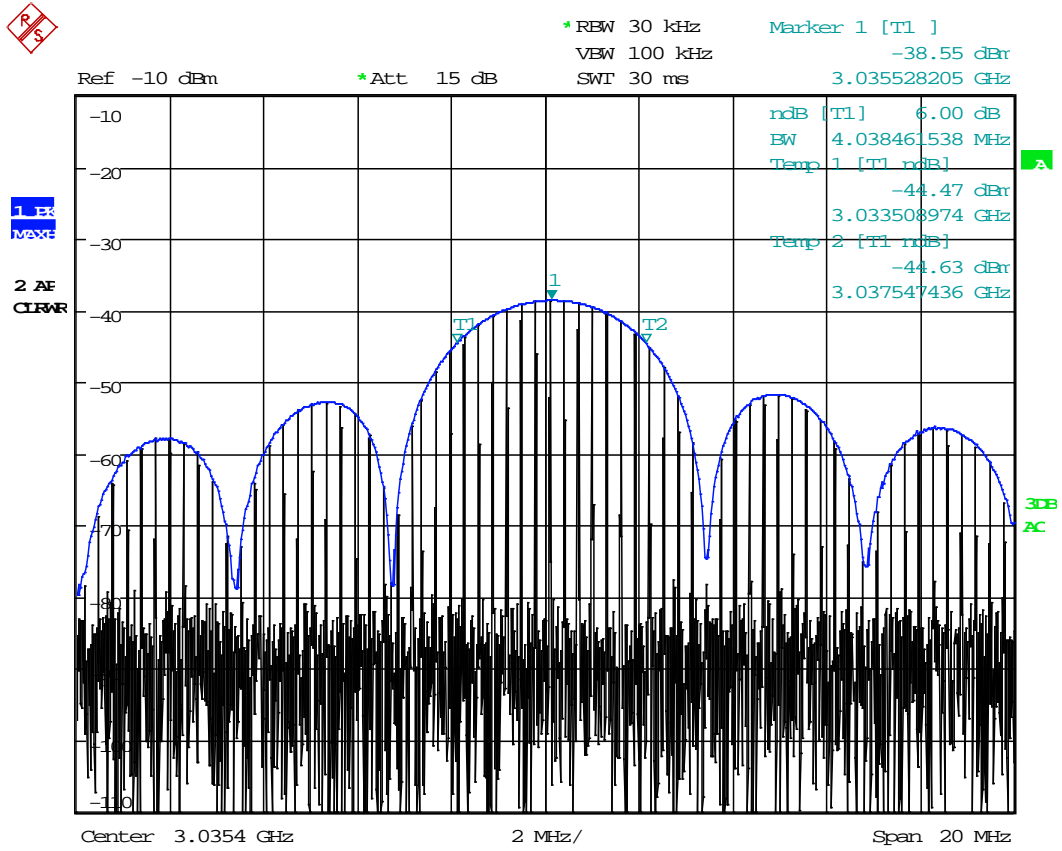

Date: 25.SEP.2015 06:52:01

**P0N @ 50°C (Nominal Voltage)**

Center Frequency = (T1 + T2)/2  
 = (3.033508974 GHz + 3.037547436 GHz) / 2  
 = 6.07105641 / 2  
 = 3.035528205 GHz

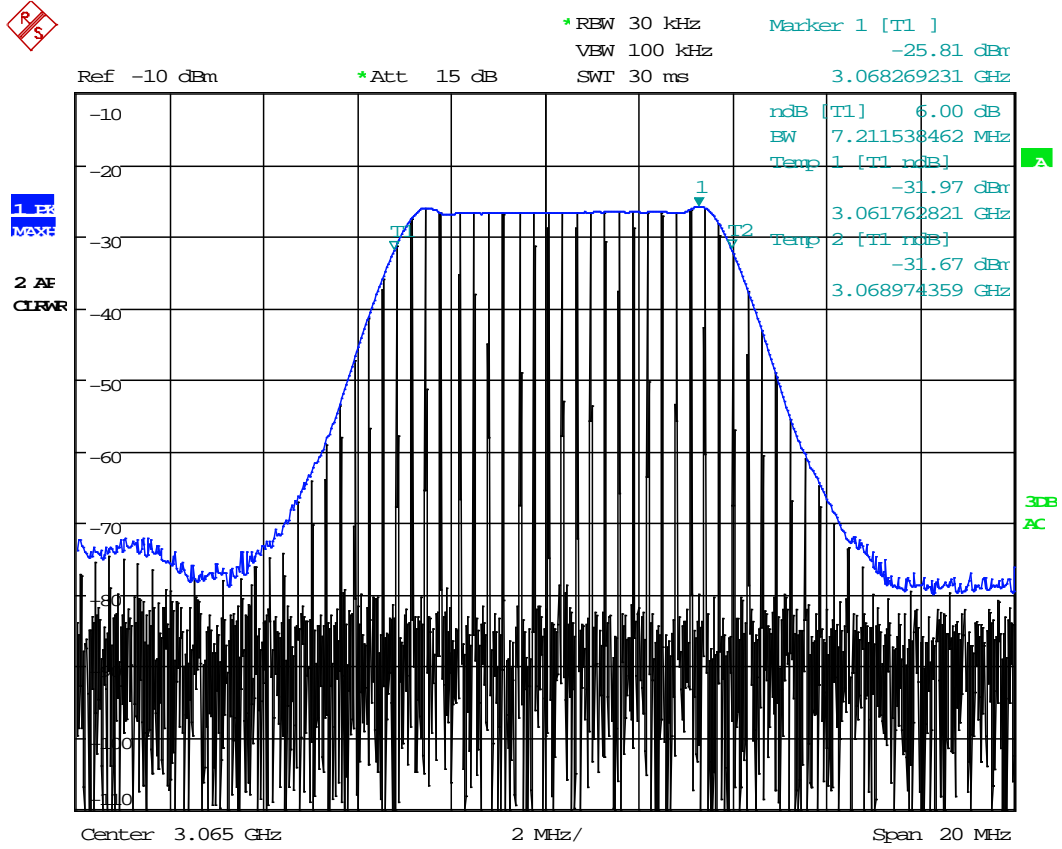

Date: 25.SEP.2015 06:51:10

**Q0N @ 50°C (Nominal Voltage)**

Center Frequency = (T1 + T2)/2  
 = (3.061762821 GHz + 3.068974359 GHz) / 2  
 = 6.13073718 / 2  
 = 3.06536859 GHz



## 2.3 OCCUPIED BANDWIDTH

### 2.3.1 Specification Reference

Part 2.1049 and 80.211(f) / RSS-238 3.2

### 2.3.2 Standard Applicable

(f) The mean power when using emissions other than those in paragraphs (a), (b), (c) and (d) of this section:

- (1) On any frequency removed from the assigned frequency by more than 50 percent up to and including 100 percent of the authorized bandwidth: At least 25 dB;
- (2) On any frequency removed from the assigned frequency by more than 100 percent up to and including 250 percent of the authorized bandwidth: At least 35 dB; and
- (3) On any frequency removed from the assigned frequency by more than 250 percent of the authorized bandwidth: At least 43 plus  $10\log_{10}$  (mean power in watts) dB.

In addition to the required information and measurements specified in RSS-Gen, the test report submitted with the application shall contain the 40 dB bandwidth. 40 dB bandwidth is the width of a frequency band, such that below the lower and above the upper frequency limits, the spectral power density is 40 dB down related to the maximum inband spectral power density.

### 2.3.3 Equipment Under Test and Modification State

Serial No: LC60577 / Default Test Configuration

### 2.3.4 Date of Test/Initial of test personnel who performed the test

September 29, 2015 / FSC

### 2.3.5 Test Equipment Used

The major items of test equipment used for the above tests are identified in Section 3.1.

### 2.3.6 Environmental Conditions/ Test Location

Test performed at TÜV SÜD America Inc. Rancho Bernardo facility

Ambient Temperature	23.4°C
Relative Humidity	33.5%
ATM Pressure	99.8 kPa

### 2.3.7 Additional Observations

- This is a conducted test.
- 40 dB bandwidth is not presented since the spectral power density below the lower and above the upper frequency limits are more than 40dB down related to the maximum inband spectral power density. See supporting test plots for details.



- Mask was drawn for each operating mode based from the measured authorized bandwidth.
- Emission Mask Mode of the spectrum analyzer was used for this test. Measurement mode set to Channel Power and not Peak Power.
- A correction factor of 52.4 dB was used to compensate for the high power directional coupler, external attenuator and cable used.
- P0N and Q0N are configured to transmit at the same time. Measurement bandwidth was adjusted accordingly to show the frequency of interest with the exception of P0N SP1 where Q0N was included to show compliance with frequency removed from the assigned frequency by more than 250 percent of the authorized bandwidth.

### 2.3.8 Test Results

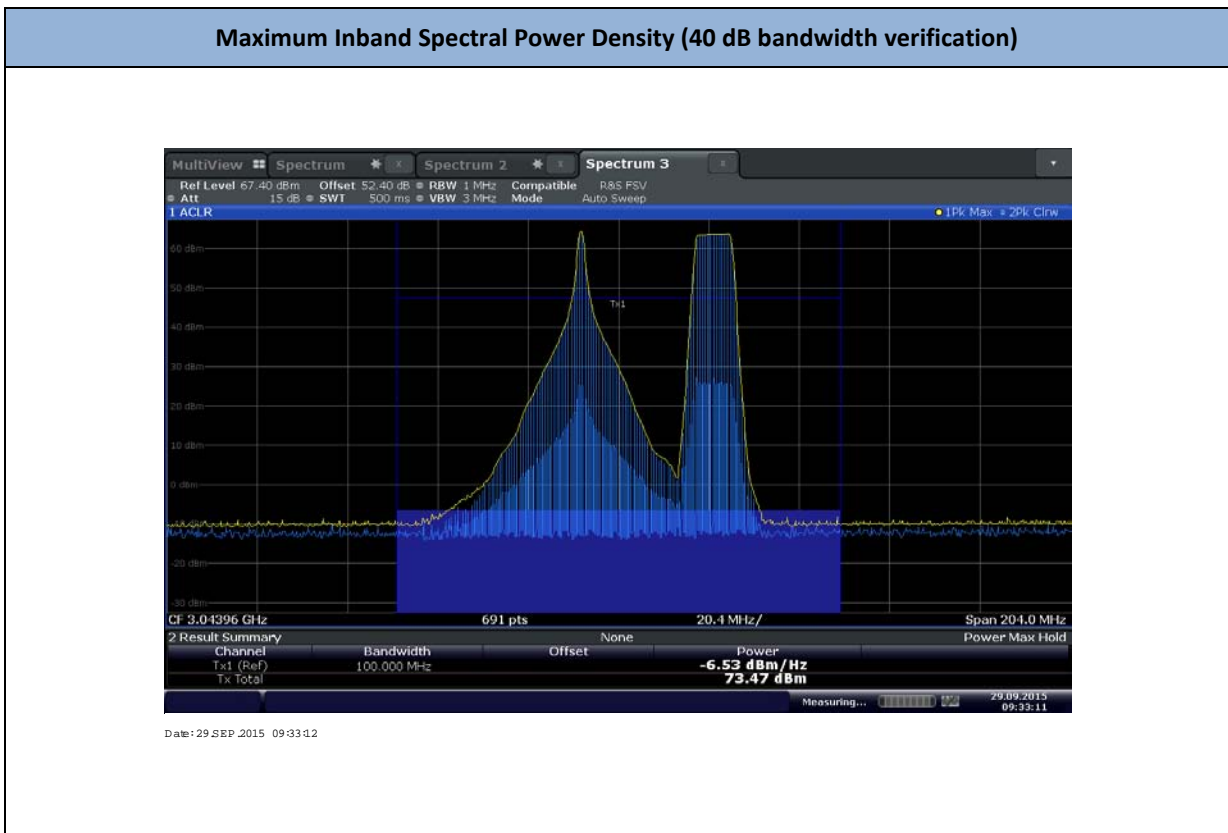



**Spectral Power Density @ below the lower frequency limit (2900 MHz)**



Date: 29 SEP 2015 09:57:58

**Spectral Power Density @ above the upper frequency limit (3100 MHz)**

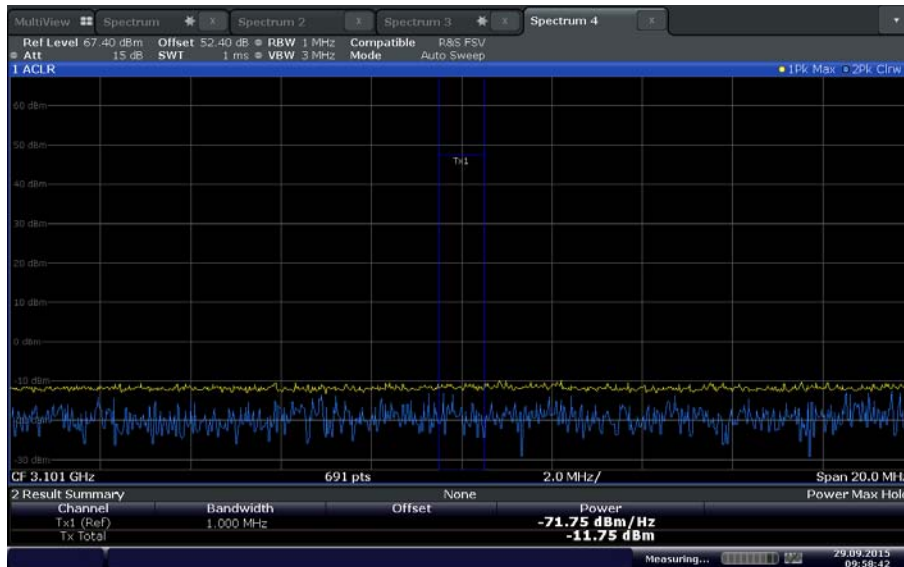

Date: 29 SEP 2015 09:58:43



**PON SP1**

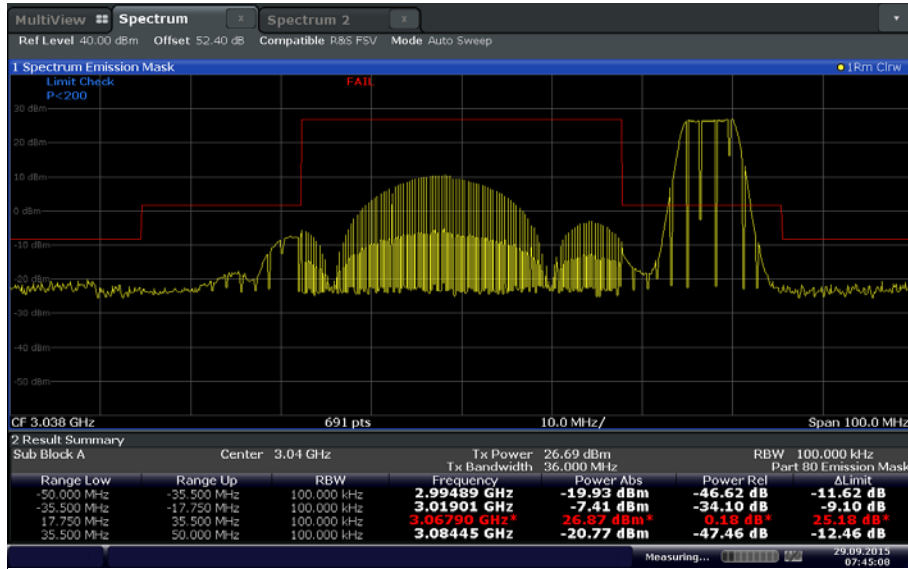

Date: 29 SEP 2015 07:45:07

Failing data is due to adjacent QON transmission. PON SP1 complies with the mask requirement of the Rule Part

**PON MP1**

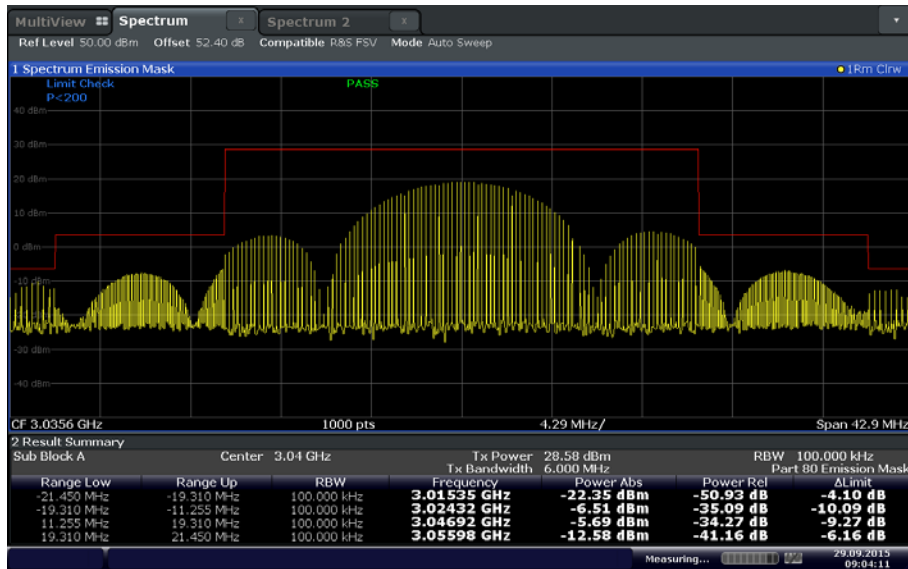

Date: 29 SEP 2015 09:04:11



PON MP2

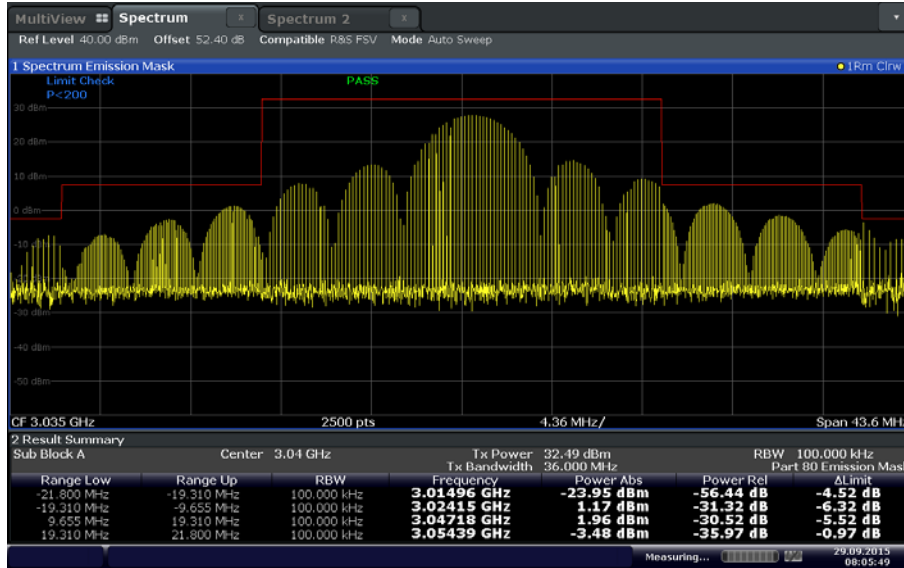

Date: 29 SEP 2015 08:05:49

PON LP1

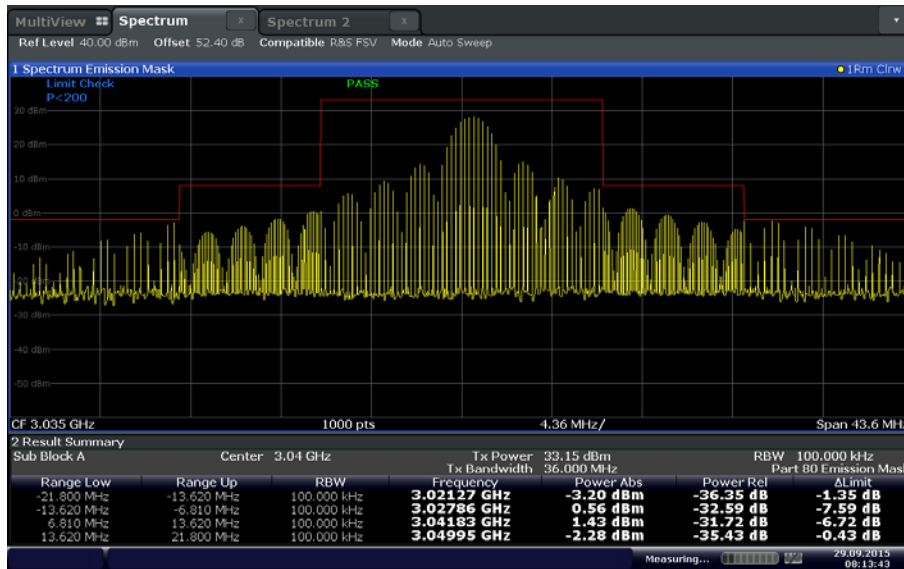

Date: 29 SEP 2015 08:13:43



**P0N LP2**

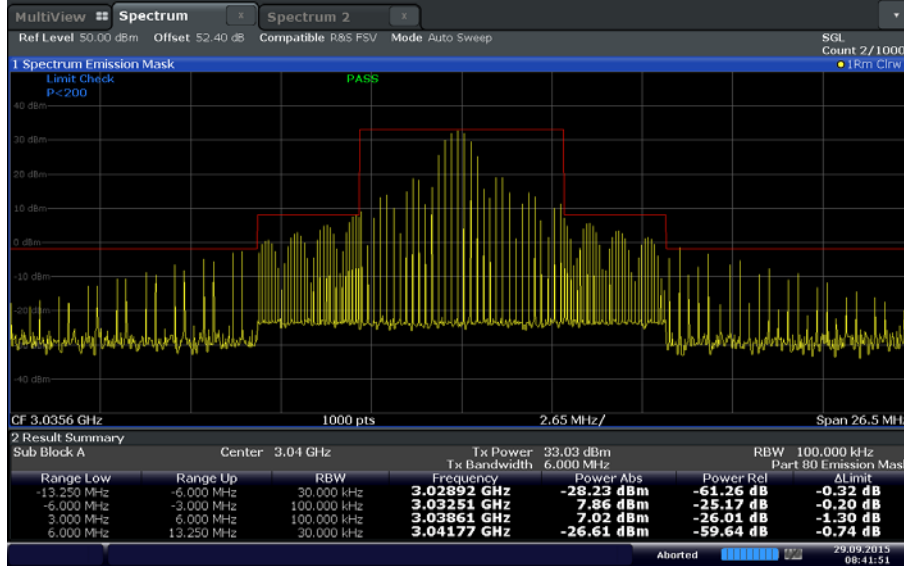

Date: 29.SEP.2015 08:41:51

**Q0N SP1**

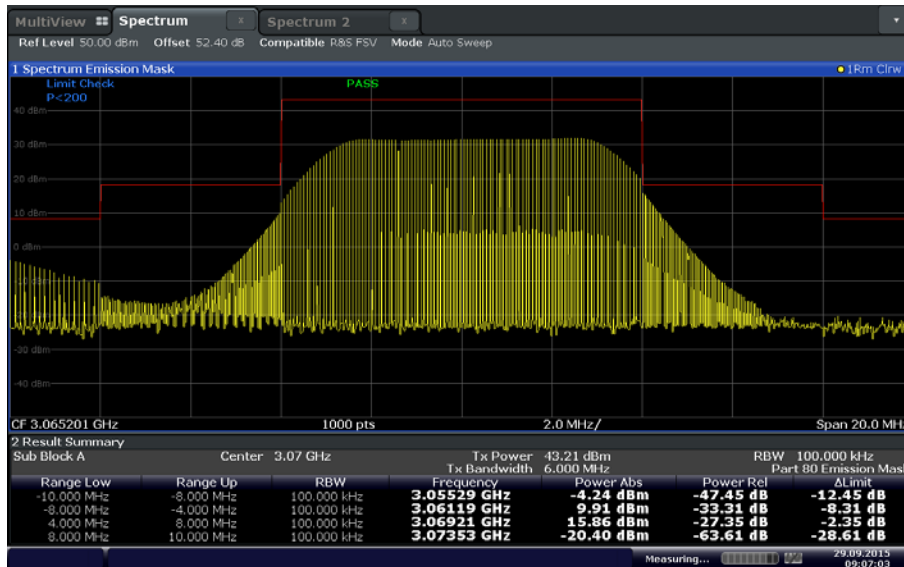

Date: 29.SEP.2015 09:07:04





**Q0N MP1**

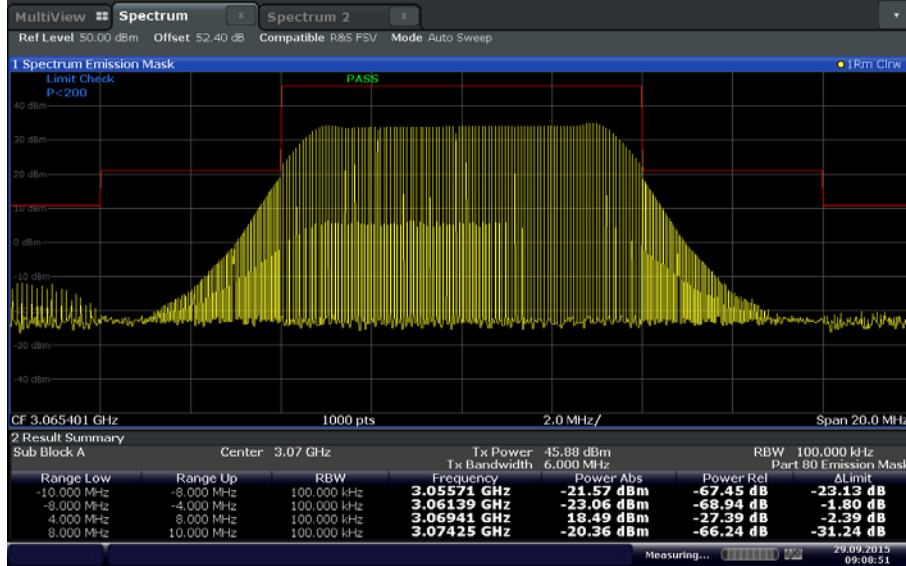

**Q0N MP2**

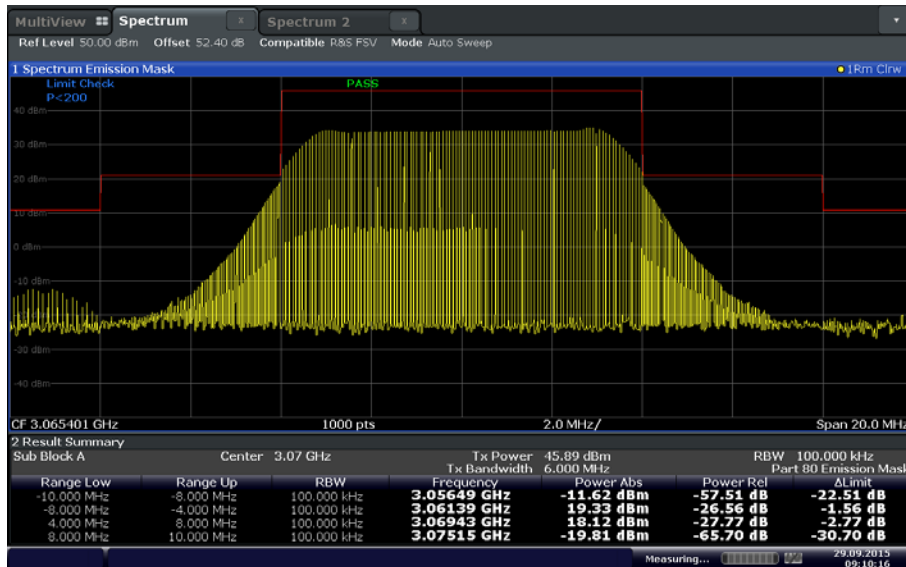



### Q0N LP1

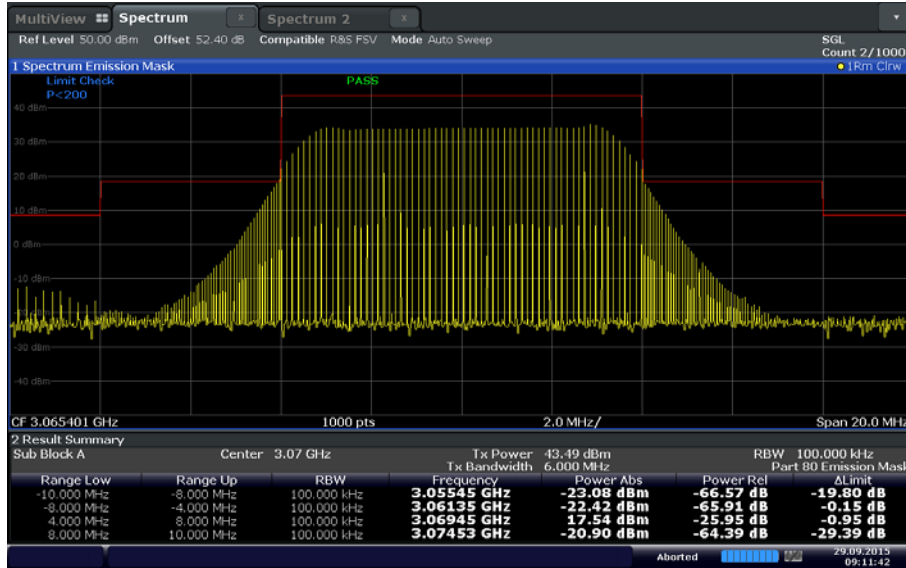

Date: 29.SEP.2015 09:11:42

### Q0N LP2

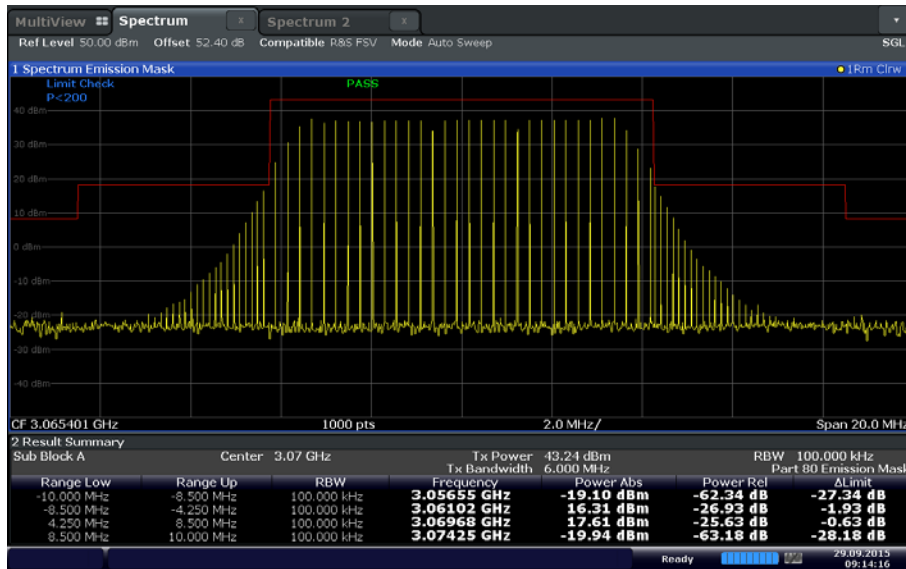

Date: 29.SEP.2015 09:14:17



## 2.4 99% EMISSION BANDWIDTH

### 2.4.1 Specification Reference

RSS-Gen Clause 4.6.1

### 2.4.2 Standard Applicable

When an occupied bandwidth value is not specified in the applicable RSS, the transmitted signal bandwidth to be reported is to be its 99% emission bandwidth, as calculated or measured.

The transmitter shall be operated at its maximum carrier power measured under normal test conditions. The span of the analyzer shall be set to capture all products of the modulation process, including the emission skirts. The resolution bandwidth shall be set to as close to 1% of the selected span as is possible without being below 1%. The video bandwidth shall be set to 3 times the resolution bandwidth. Video averaging is not permitted. Where practical, a sampling detector shall be used given that a peak or peak hold may produce a wider bandwidth than actual.

The trace data points are recovered and directly summed in linear terms. The recovered amplitude data points, beginning at the lowest frequency, are placed in a running sum until 0.5% of the total is reached and that frequency recorded. The process is repeated for the highest frequency data points. This frequency is recorded. The span between the two recorded frequencies is the occupied bandwidth.

### 2.4.3 Equipment Under Test and Modification State

Serial No: LC60577 / Default Test Configuration

### 2.4.4 Date of Test/Initial of test personnel who performed the test

September 29, 2015 / FSC

### 2.4.5 Test Equipment Used

The major items of test equipment used for the above tests are identified in Section 3.1.

### 2.4.6 Environmental Conditions/ Test Location

Test performed at TÜV SÜD America Inc. Rancho Bernardo facility

Ambient Temperature	23.4°C
Relative Humidity	33.5%
ATM Pressure	99.8 kPa

### 2.4.7 Additional Observations

- This is a conducted test.
- A correction factor of 52.4 dB was used to compensate for the high power directional coupler, external attenuator and cable used.
- Span is wide enough to capture the channel transmission.
- RBW was set to auto (approx. 1% of the span).



- VBW is always > RBW.
- Sweep is auto.
- Detector is peak.
- The % Power Bandwidth setting in the spectrum analyzer was set to 99% (default).
- The Channel Bandwidth measurement function of the spectrum analyzer was used for this test.

2.4.8 **Test Results**

Operating Mode	P0N 99% Occupied Bandwidth (MHz)	Q0N 99% Occupied Bandwidth (MHz)
<i>SP1</i>	35.43	7.53
<i>MP1</i>	22.51	7.87
<i>MP2</i>	19.31	7.87
<i>LP1</i>	13.62	7.87
<i>LP2</i>	5.974	8.16

*See actual test plots on the following pages.*

**P0N SP1**

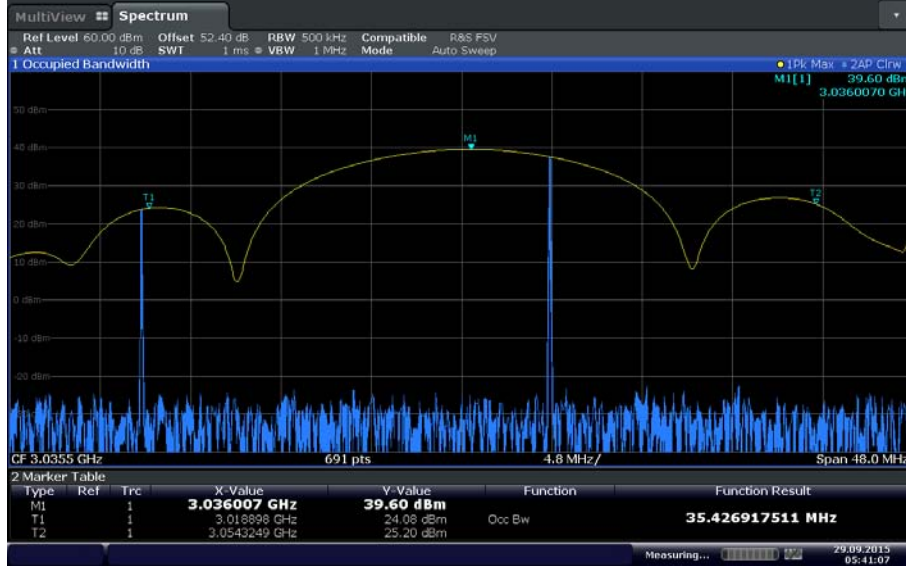

Date: 29.SEP.2015 05:41:07

**P0N MP1**

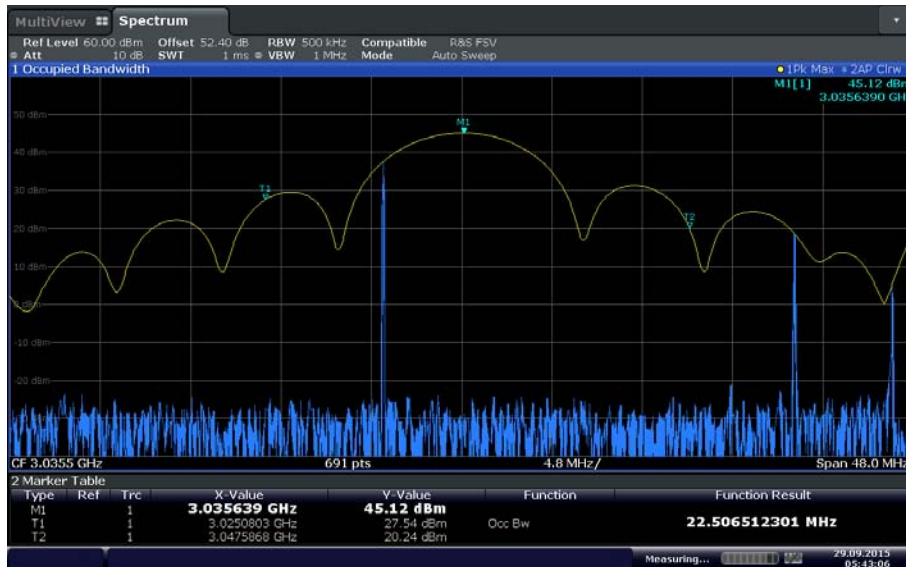

Date: 29.SEP.2015 05:43:07



PON MP2

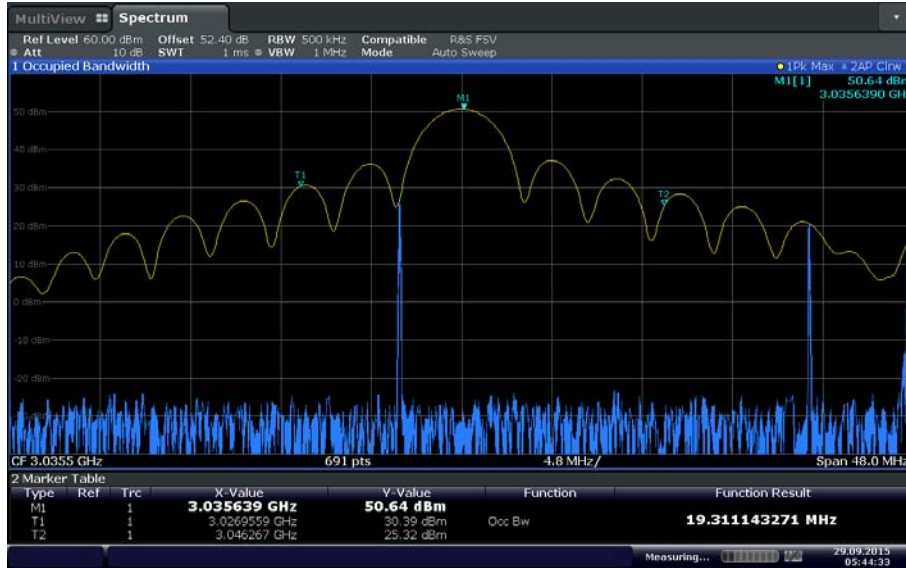

Date: 29.SEP.2015 05:44:33

PON LP1

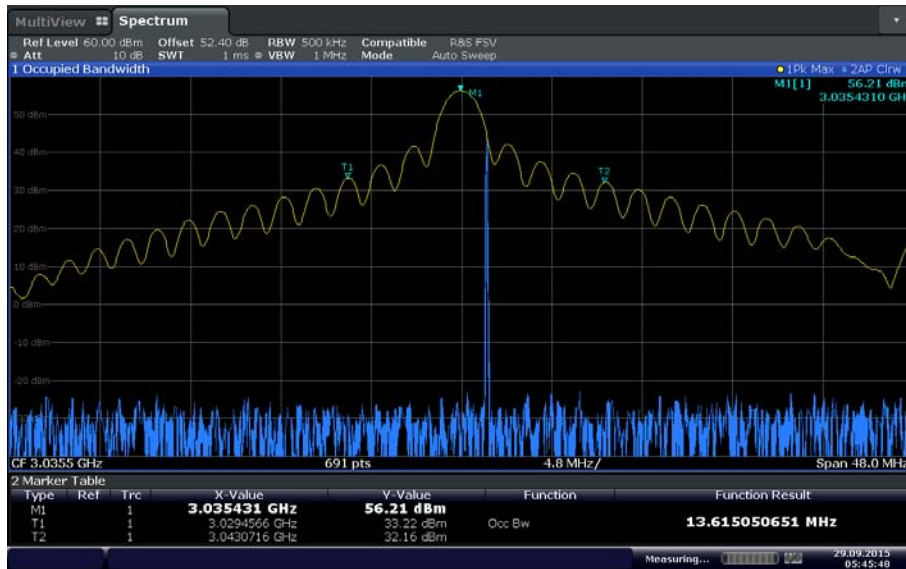

Date: 29.SEP.2015 05:45:48



**P0N LP2**

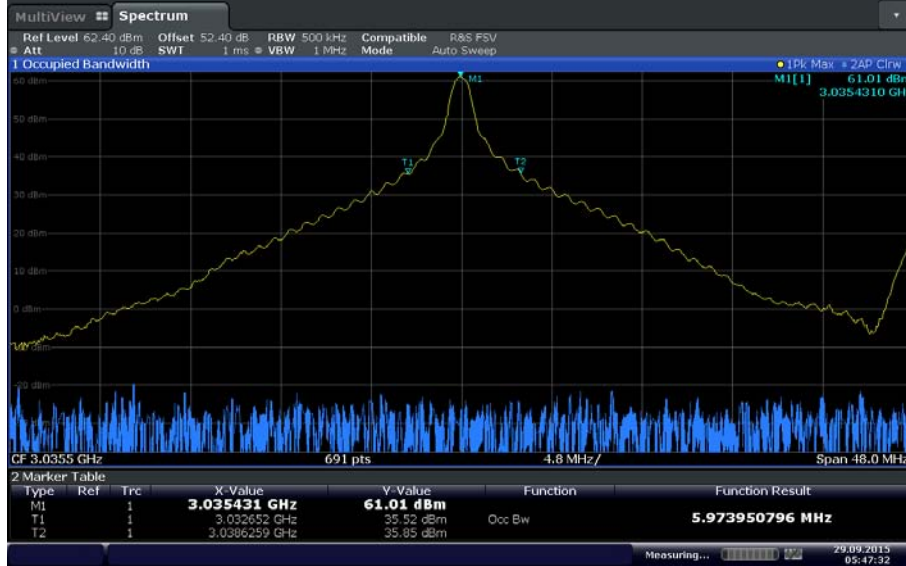

Date: 29 SEP 2015 05:47:32

**Q0N SP1**

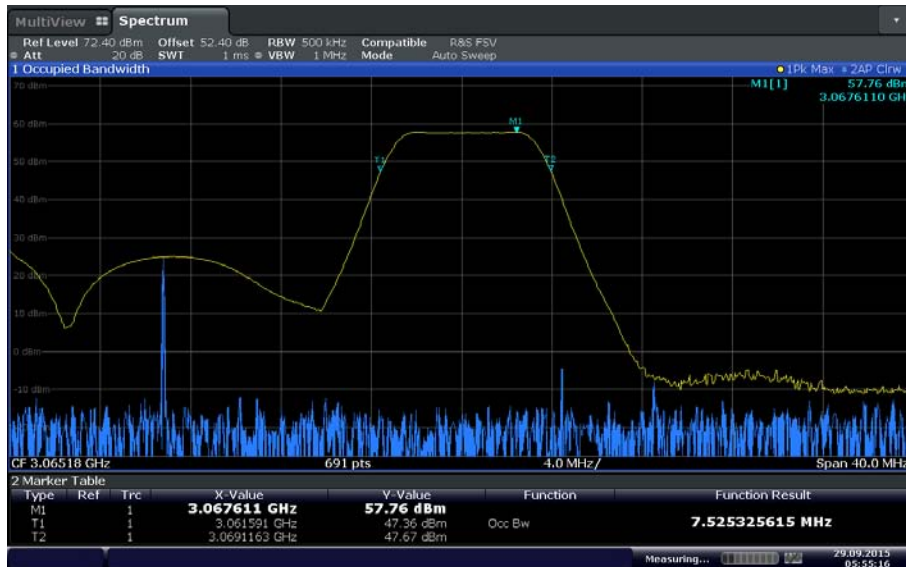

Date: 29 SEP 2015 05:55:16



Q0N MP1

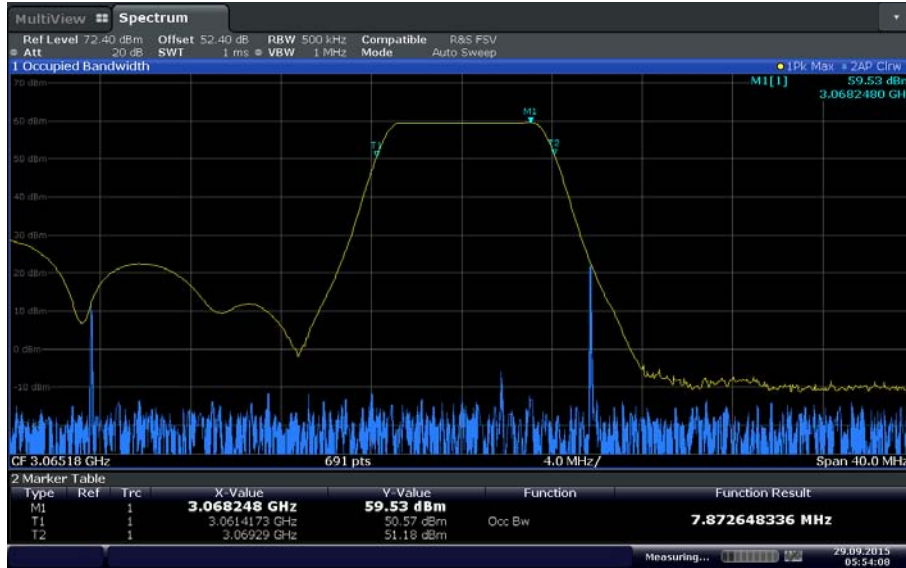

Date: 29.SEP.2015 05:54:08

Q0N MP2

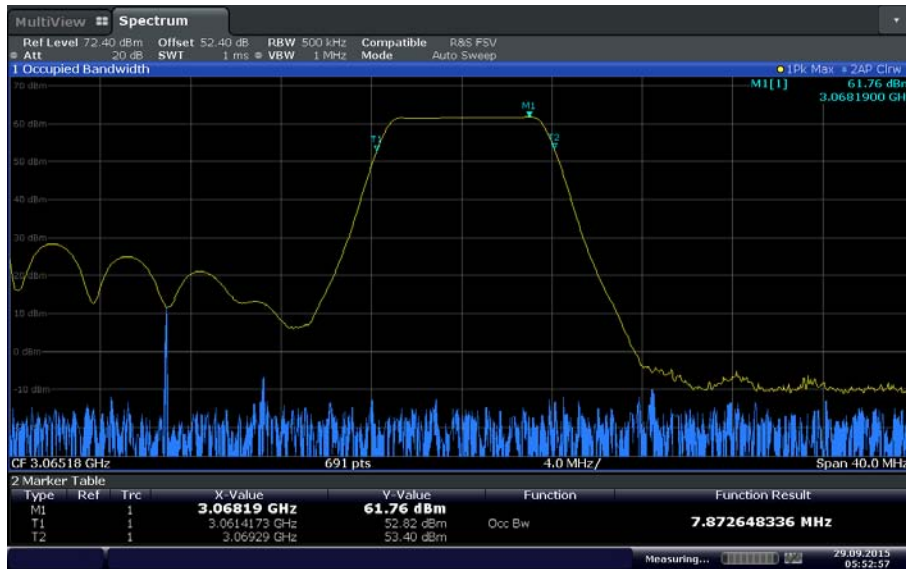

Date: 29.SEP.2015 05:52:57





**Q0N LP1**

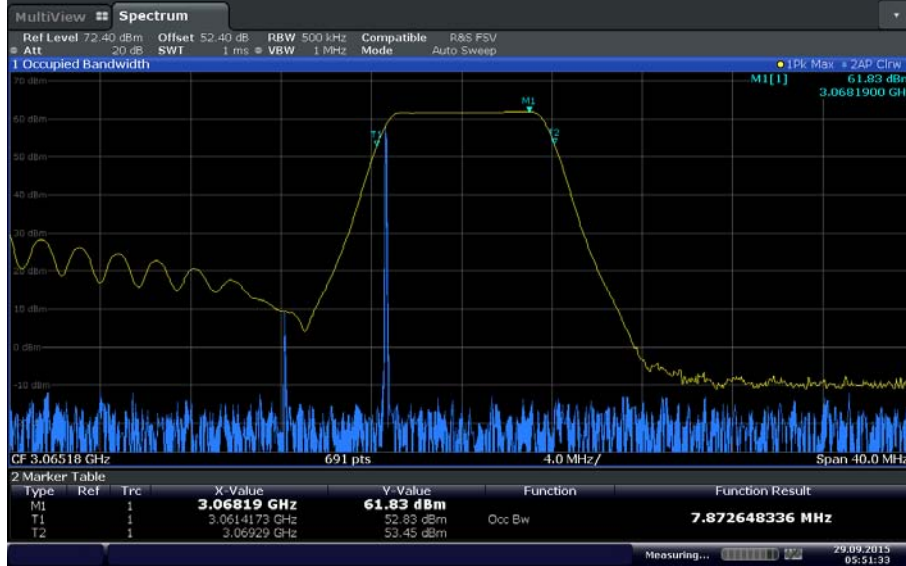

Date: 29.SEP.2015 05:51:34

**Q0N LP2**

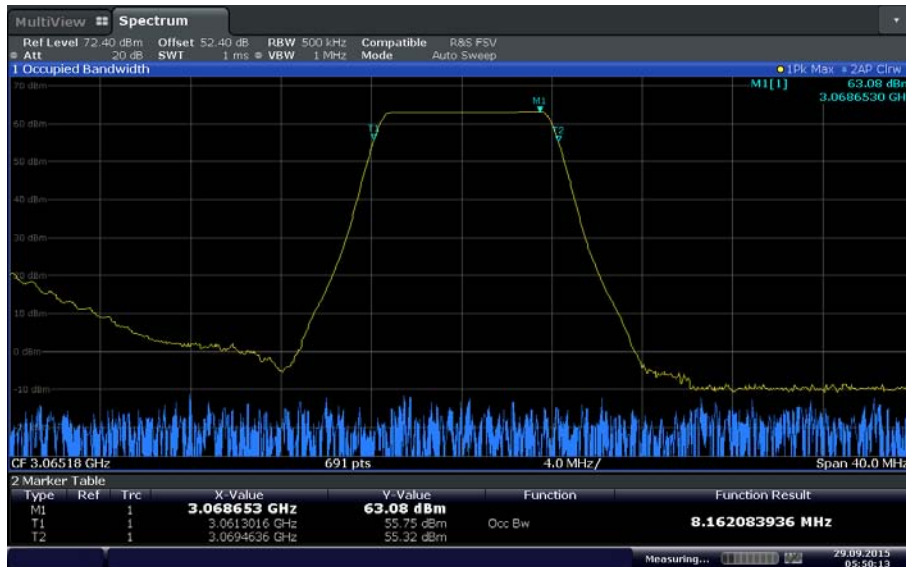

Date: 29.SEP.2015 05:50:13



**2.5 MODULATION CHARACTERISTICS**

**2.5.1 Specification Reference**

Part 2.1047 (d) and Part 80.213 (g) / RSS-238 3.2

**2.5.2 Standard Applicable**

(d) Other types of equipment. A curve or equivalent data which shows that the equipment will meet the modulation requirements of the rules under which the equipment is to be licensed.

(g) Radar stations operating in the bands above 2.4 GHz may use any type of modulation consistent with the bandwidth requirements in §80.209(b).

**2.5.3 Equipment Under Test and Modification State**

Serial No: LC60577 / Default Test Configuration

**2.5.4 Date of Test/Initial of test personnel who performed the test**

September 23, 2015/FSC

**2.5.5 Test Equipment Used**

The major items of test equipment used for the above tests are identified in Section 3.1.

**2.5.6 Environmental Conditions**

Test performed at TÜV SÜD America Inc. Rancho Bernardo facility.

Ambient Temperature	25.3 °C
Relative Humidity	44.3 %
ATM Pressure	99.5 kPa

**2.5.7 Test Results**

See Section 2.1.8 of this test report. Pulse Rise Time, PRF and Pulse Width of all operating modes of both PON and QON were measured in order to calculate Peak Power (dBm). Only plots for lowest power operating mode (SP1) and highest power operating mode (LP2) were presented. Methodology specified in RSS-238 was used to determine Pulse Width (t) and Pulse Rise Time (t<sub>r</sub>).

The maximum emission for each mode was verified to occur within the authorized bandwidth and was not closer than 1.5/T MHz to the upper and lower limits of the authorized bandwidth where "T" is the pulse duration in microseconds

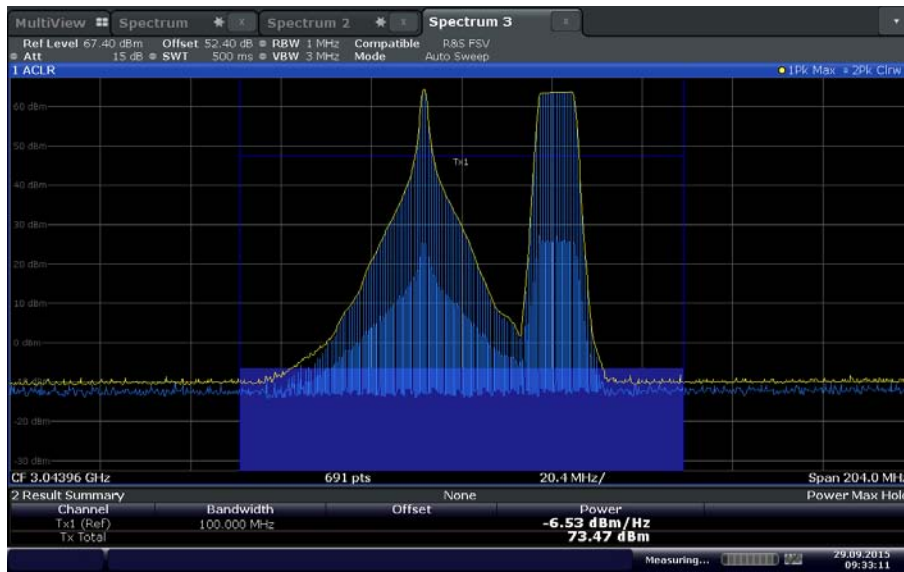

Date: 29\_SEP\_2015 09:33:12

**Plot showing maximum emissions of the EUT occurring well within the calculated band limit using worst case pulse duration (2900.0033 MHz to 3099.9967 MHz frequency band).**



**2.6 SPURIOUS EMISSIONS AT ANTENNA PORT**

**2.6.1 Specification Reference**

Part 2.1051 and Part 80.211 (f) / RSS-238 4.3

**2.6.2 Standard Applicable**

(f) The mean power when using emissions other than those in paragraphs (a), (b), (c) and (d) of this section:

- (1) On any frequency removed from the assigned frequency by more than 50 percent up to and including 100 percent of the authorized bandwidth: At least 25 dB;
- (2) On any frequency removed from the assigned frequency by more than 100 percent up to and including 250 percent of the authorized bandwidth: At least 35 dB; and
- (3) On any frequency removed from the assigned frequency by more than 250 percent of the authorized bandwidth: At least 43 plus  $10\log_{10}$  (mean power in watts) dB.

The unwanted emission and the transmitter power shall be measured using a peak detector.

The unwanted emission power in any 1 MHz bandwidth shall be attenuated below the transmitter peak power by at least 20 dB per decade from the edge of the 40 dB bandwidth and beyond.

The unwanted emissions power shall not need to be attenuated more than 60 dB below the transmitter peak power.

**2.6.3 Equipment Under Test and Modification State**

Serial No: LC60577 / Default Test Configuration

**2.6.4 Date of Test/Initial of test personnel who performed the test**

September 29, 2015 / FSC

**2.6.5 Test Equipment Used**

The major items of test equipment used for the above tests are identified in Section 3.1.

**2.6.6 Environmental Conditions/ Test Location**

Test performed at TÜV SÜD America Inc. Rancho Bernardo facility

Ambient Temperature	23.4°C
Relative Humidity	33.5%
ATM Pressure	99.8 kPa

**2.6.7 Additional Observations**

- This is a conducted test.
- A transducer factor (TDF) was used to compensate for the high power directional coupler, external attenuator and cable used.



- Sweep points were set to maximum.
- Detector is peak.
- RBW is 1MHz while VBW was set to 3x RBW.
- Only showing frequencies removed from the assigned frequency by more than 250 percent of the authorized bandwidth. Frequencies removed less than 250 percent are covered under Section 2.3 of this test report.
- Limit used was fundamental power (dBW) less 43 plus  $10\log_{10}$  (mean power in watts) dB.
- There were no emissions observed other than the fundamental. EUT complies with the RSS-238 requirement.
- There were no emissions observed above 26.5 GHz, only up to 26.5 GHz plots presented.

2.6.8 **Results**

Complies. See attached plots.

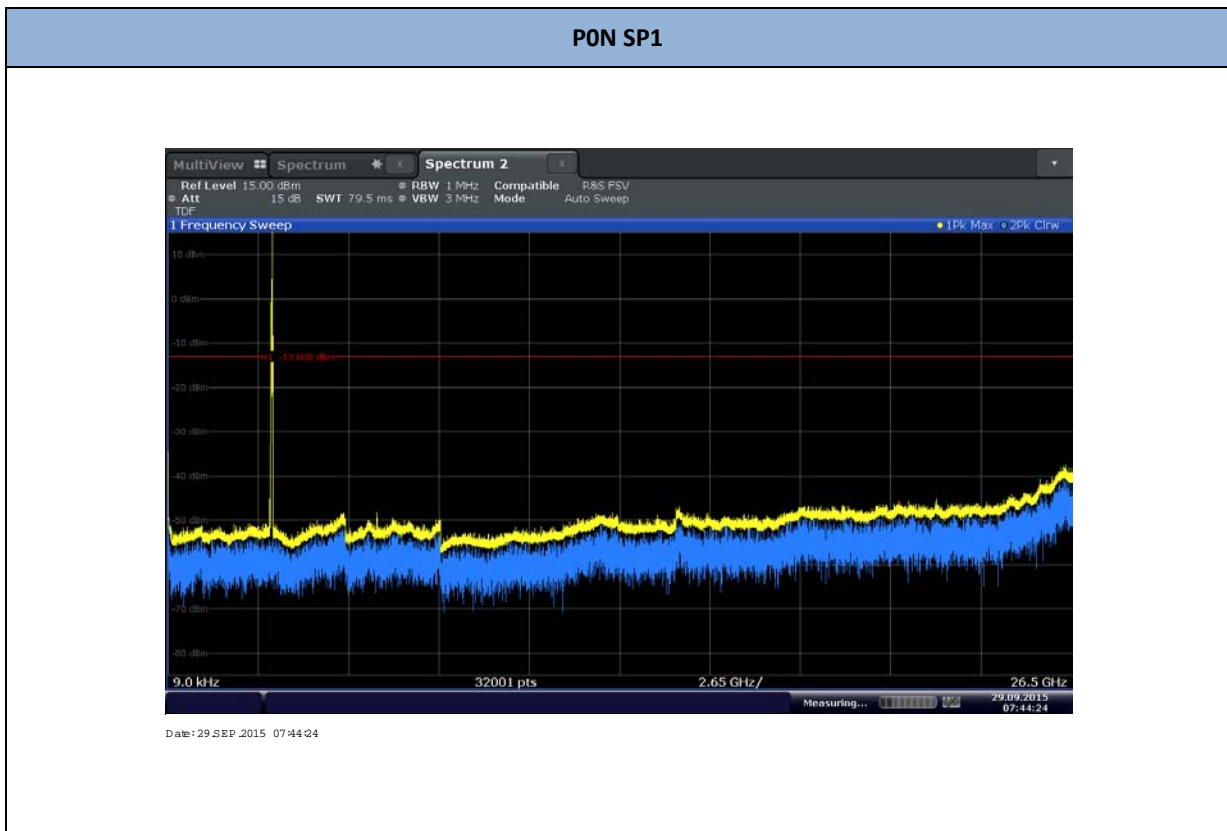

PON MP1

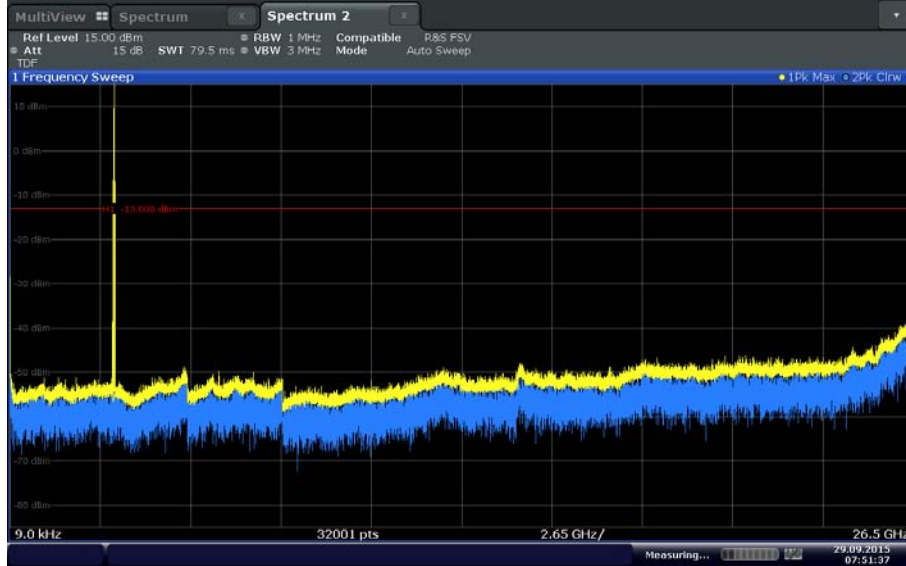

Date: 29.SEP.2015 07:51:37

PON MP2

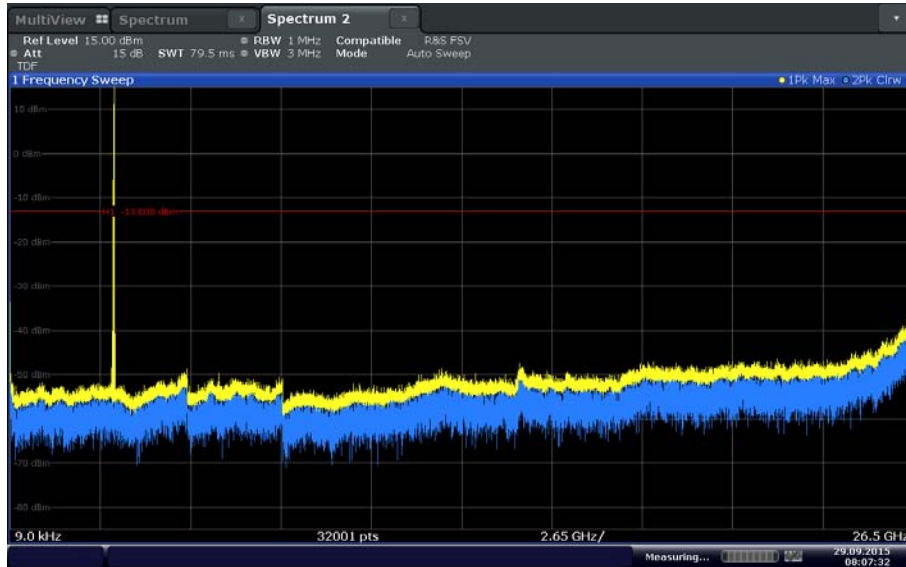

Date: 29.SEP.2015 08:07:32



America

P0N LP1

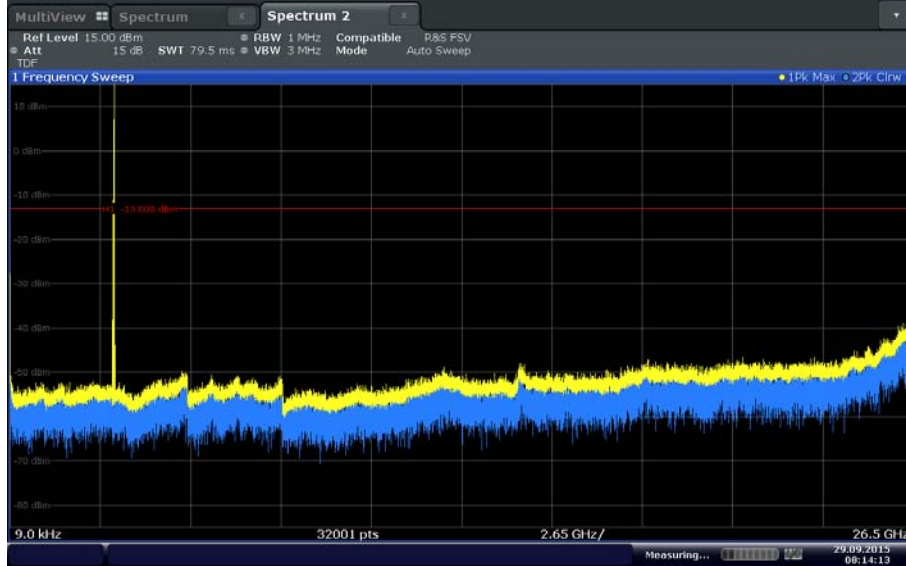

Date: 29 SEP 2015 08:14:13

P0N LP2

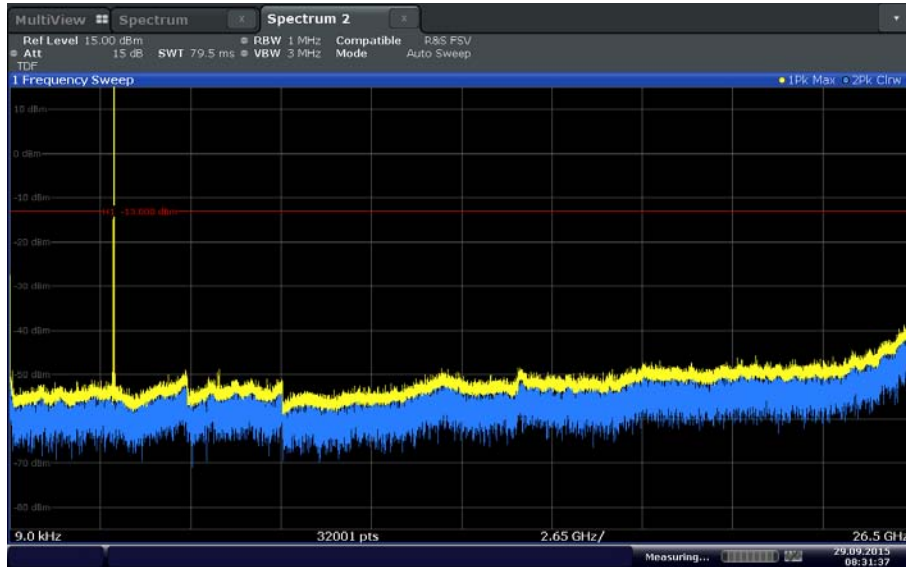

Date: 29 SEP 2015 08:31:37



America

**Q0N SP1**

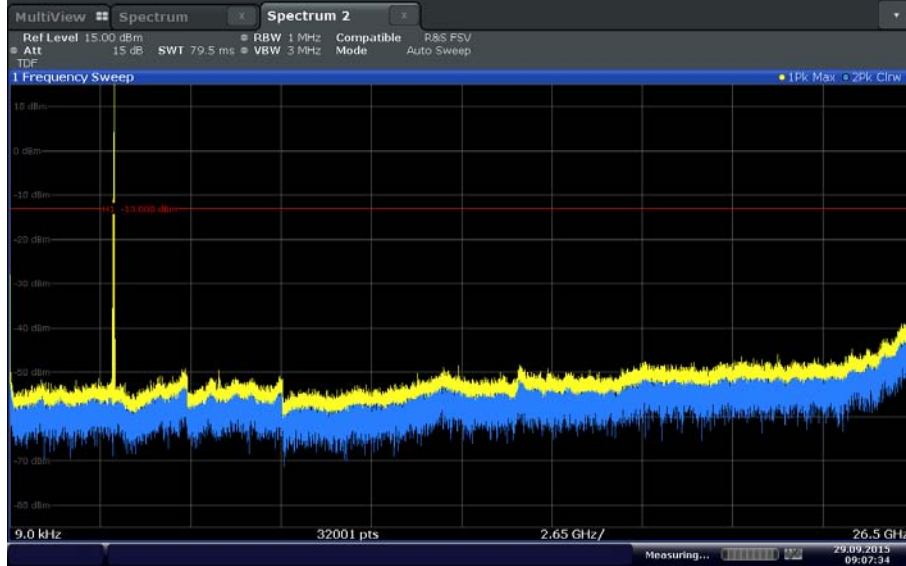

Date: 29.SEP.2015 09:07:34

**Q0N MP1**

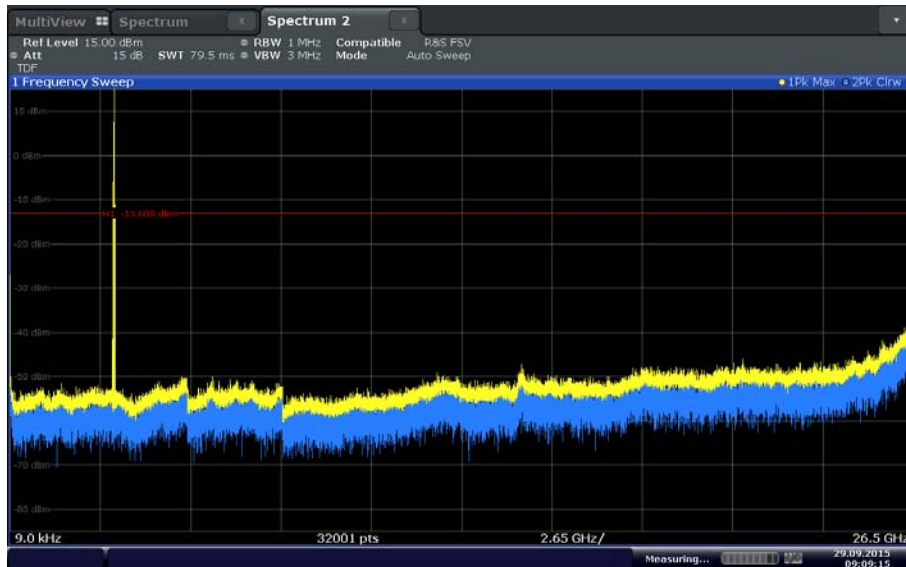

Date: 29.SEP.2015 09:09:16



Q0N MP2

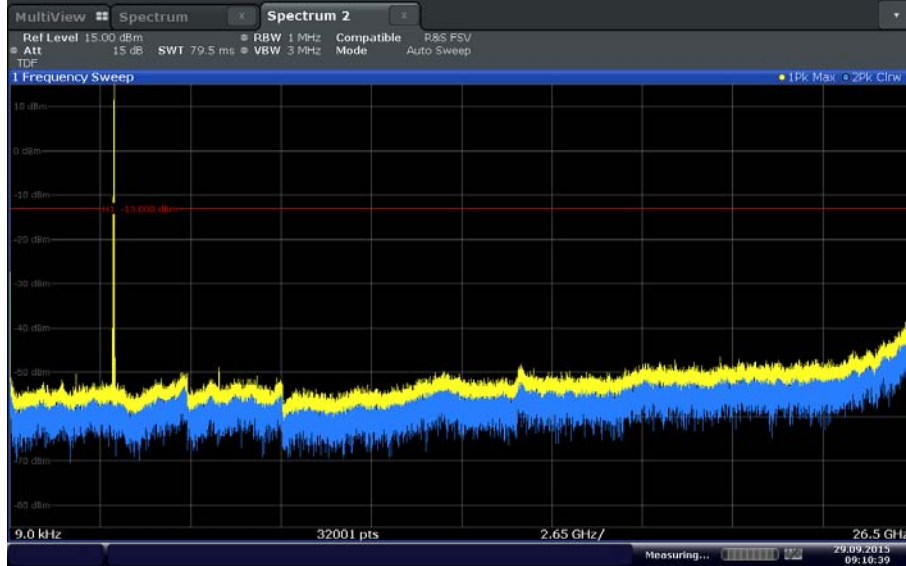

Q0N LP1

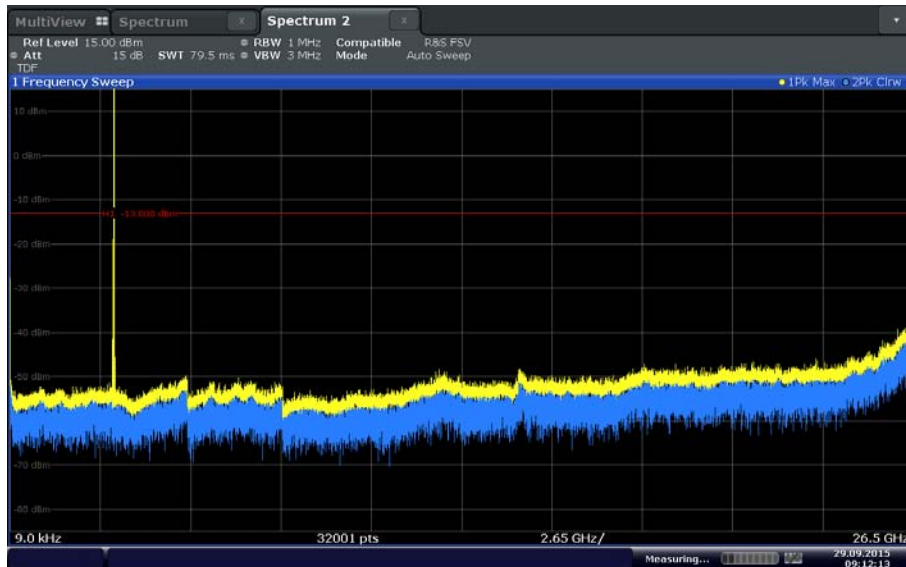

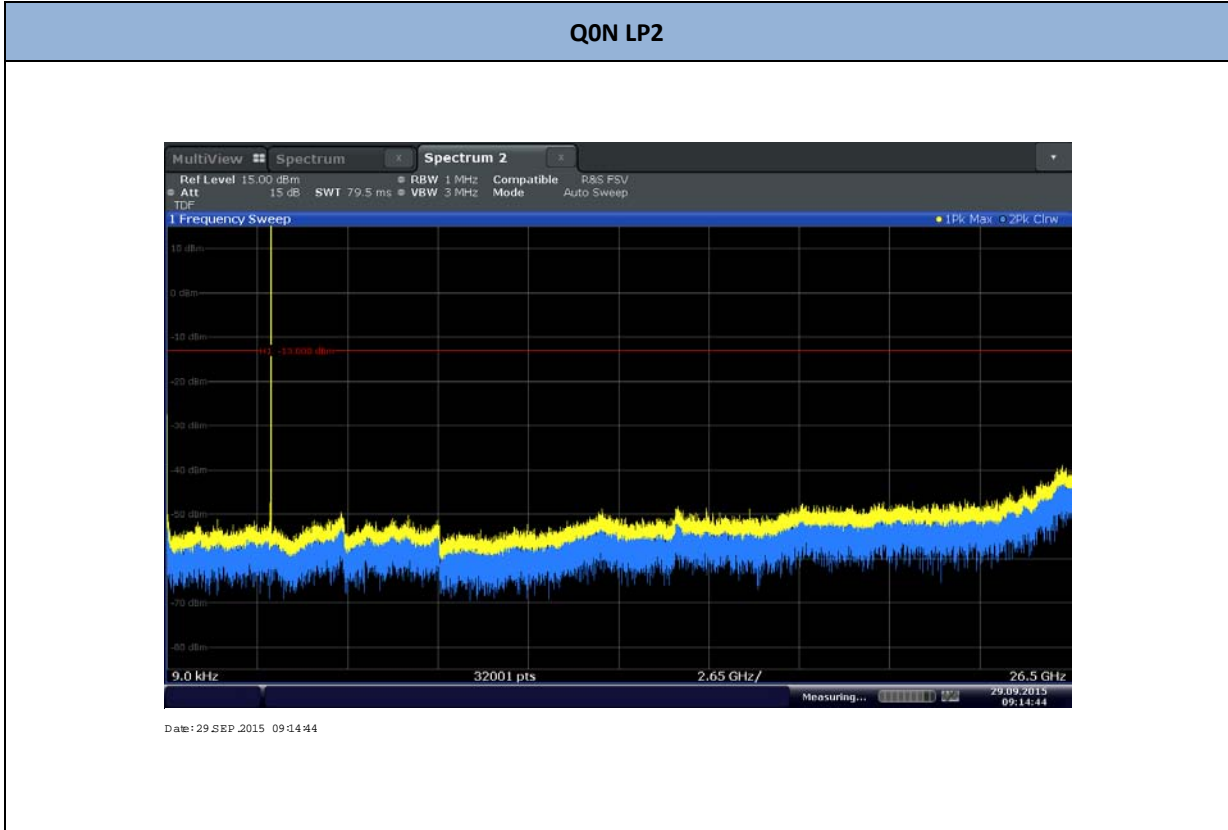



## 2.7 FIELD STRENGTH OF SPURIOUS RADIATION

### 2.7.1 Specification Reference

Part 2.1053, Part 80.211 (f) / RSS-238 4.3

### 2.7.2 Standard Applicable

(a) Measurements shall be made to detect spurious emissions that may be radiated directly from the cabinet, control circuits, power leads, or intermediate circuit elements under normal conditions of installation and operation. Curves or equivalent data shall be supplied showing the magnitude of each harmonic and other spurious emission. For this test, single sideband, independent sideband, and controlled carrier transmitters shall be modulated under the conditions specified in paragraph (c) of §2.1049, as appropriate. For equipment operating on frequencies below 890 MHz, an open field test is normally required, with the measuring instrument antenna located in the far-field at all test frequencies. In the event it is either impractical or impossible to make open field measurements (e.g. a broadcast transmitter installed in a building) measurements will be accepted of the equipment as installed. Such measurements must be accompanied by a description of the site where the measurements were made showing the location of any possible source of reflections which might distort the field strength measurements. Information submitted shall include the relative radiated power of each spurious emission with reference to the rated power output of the transmitter, assuming all emissions are radiated from halfwave dipole antennas.

The unwanted emission and the transmitter power shall be measured using a peak detector.

The unwanted emissions power shall not need to be attenuated more than 60 dB below the transmitter peak power.

### 2.7.3 Equipment Under Test and Modification State

Serial No: LC60577 / Default Test Configuration + Standby Mode

### 2.7.4 Date of Test/Initial of test personnel who performed the test

September 21 and 28, 2015/FSC

### 2.7.5 Test Equipment Used

The major items of test equipment used for the above tests are identified in Section 3.1.

### 2.7.6 Environmental Conditions

Test performed at TÜV SÜD America Inc. Rancho Bernardo facility.

Ambient Temperature	23.6 to 24.6 °C
Relative Humidity	44.4 % to 47.8 %
ATM Pressure	99.5 to 99.8kPa



#### 2.7.7 Additional Observations

- This is a radiated test using substitution method as per Unwanted Emissions: Radiated Spurious method of measurement of ANSI/TIA/EIA-603-C 2004, August 17, 2004.
- There were no emissions observed within 60 dB in reference to the rated power output of the transmitter. Substitution method verification not required. **EUT complies.**
- EUT RF output was terminated to a high power dummy load for this test.
- Measurement was done using EMC32 V8.53 automated software. Reported level is the actual level with all the correction factors factored in. Correction Factor column is for informational purposes only.

#### 2.7.8 Test Results

See attached plots.



2.7.9 Standby Mode (below 30 MHz)

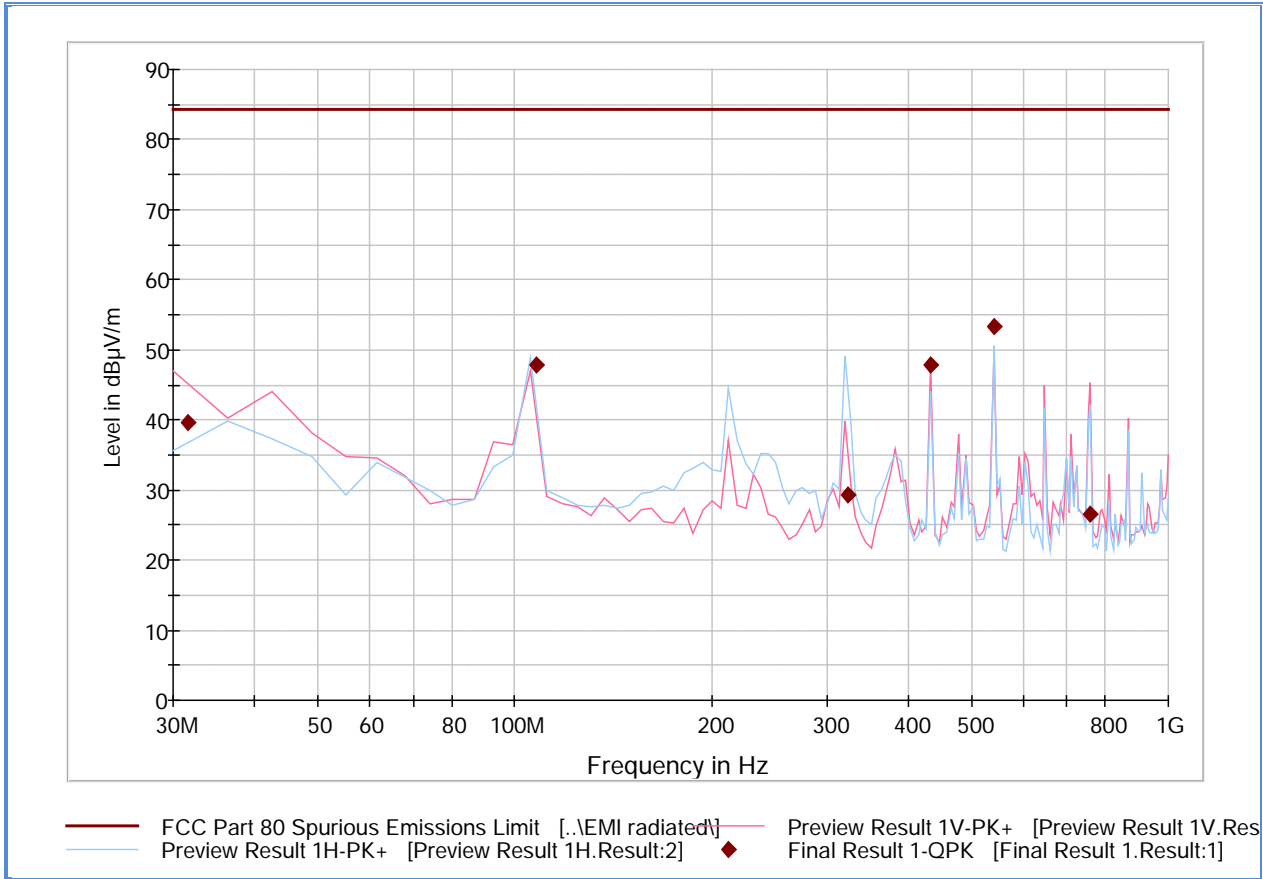

Quasi Peak Data

Frequency (MHz)	QuasiPeak (dBµV/m)	Meas. Time (ms)	Bandwidth (kHz)	Height (cm)	Polarization	Azimuth (deg)	Corr. (dB)	Margin (dB)	Limit (dBµV/m)
31.600000	39.6	1000.0	120.000	100.0	V	157.0	-12.3	44.8	84.4
107.984416	47.9	1000.0	120.000	198.0	H	272.0	-19.8	36.5	84.4
323.260260	29.2	1000.0	120.000	100.0	H	135.0	-11.8	55.2	84.4
431.956883	47.8	1000.0	120.000	100.0	V	152.0	-8.9	36.6	84.4
539.954805	53.4	1000.0	120.000	100.0	H	286.0	-5.9	31.0	84.4
757.289351	26.6	1000.0	120.000	100.0	V	175.0	-2.1	57.8	84.4

Test Notes:



2.7.10 Test Results Below 30 MHz (Worst Case Configuration – TX using LP2)

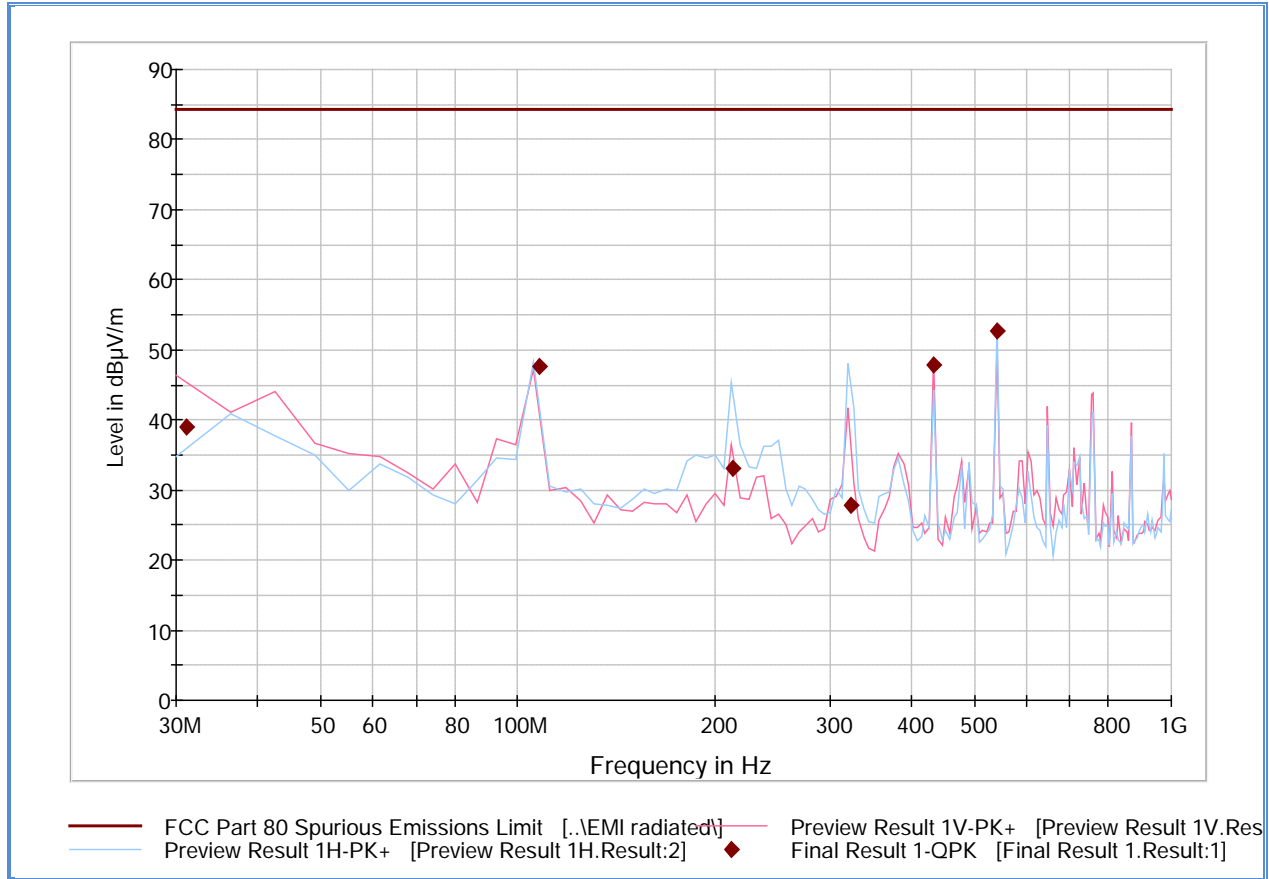

Quasi Peak Data

Frequency (MHz)	QuasiPeak (dBµV/m)	Meas. Time (ms)	Bandwidth (kHz)	Height (cm)	Polarization	Azimuth (deg)	Corr. (dB)	Margin (dB)	Limit (dBµV/m)
31.040000	38.9	1000.0	120.000	100.0	V	165.0	-12.0	45.5	84.4
107.984416	47.6	1000.0	120.000	200.0	H	267.0	-19.8	36.8	84.4
213.022338	33.2	1000.0	120.000	105.0	H	178.0	-16.0	51.2	84.4
322.700260	27.8	1000.0	120.000	100.0	H	138.0	-11.8	56.6	84.4
431.956883	47.9	1000.0	120.000	100.0	V	142.0	-8.9	36.5	84.4
539.954805	52.6	1000.0	120.000	100.0	H	279.0	-5.9	31.8	84.4

Test Notes: EUT transmitting to a load.



2.7.11 Standby Mode (above 30 MHz)

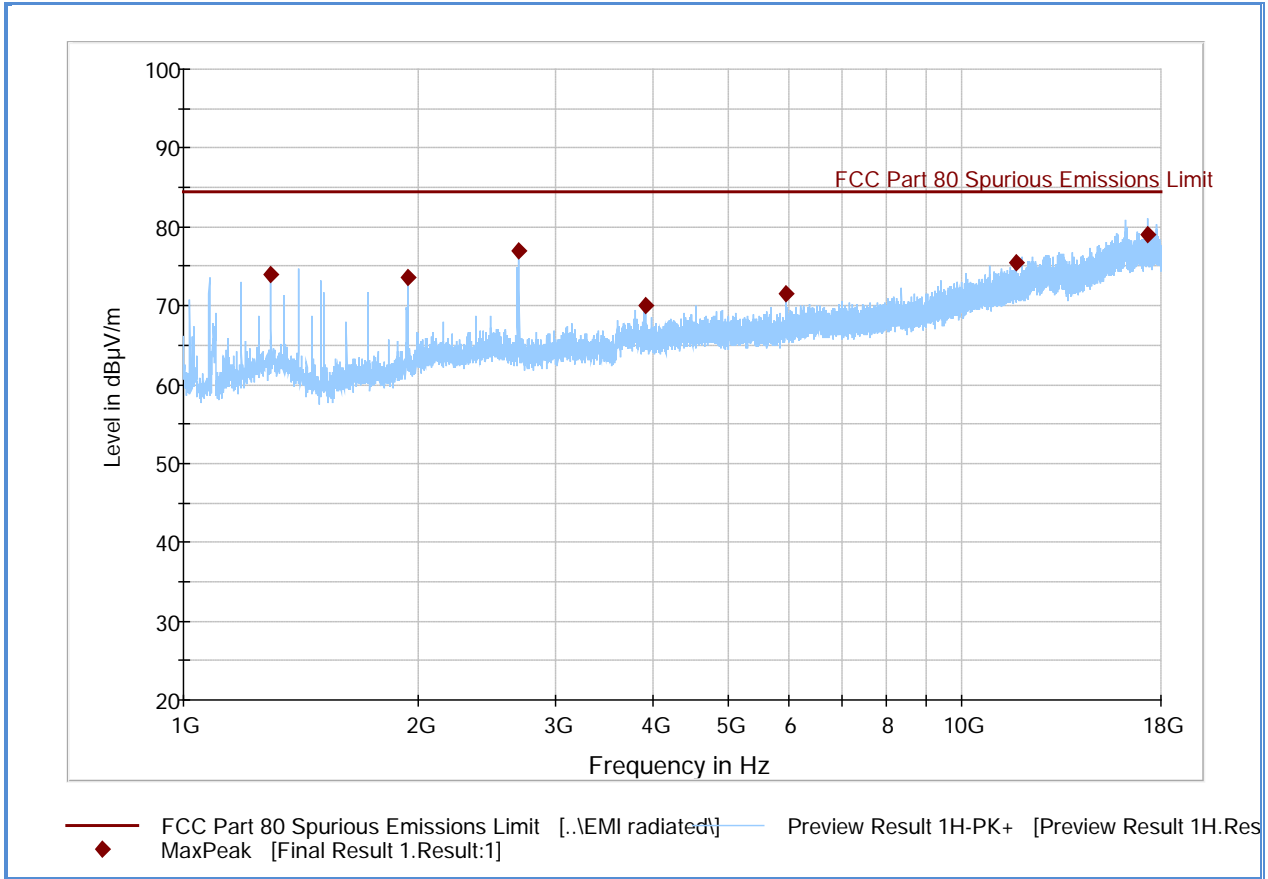

Peak Data

Frequency (MHz)	Peak (dBµV/m)	Meas. Time (ms)	Bandwidth (kHz)	Height (cm)	Polarization	Azimuth (deg)	Corr. (dB)	Margin (dB)	Limit (dBµV/m)
1295.800000	74.0	1000.0	1000.000	202.3	H	330.0	30.9	10.4	84.4
1943.500000	73.6	1000.0	1000.000	116.7	H	96.0	33.2	10.8	84.4
2699.433333	76.9	1000.0	1000.000	206.5	H	0.0	35.3	7.5	84.4
3920.600000	70.0	1000.0	1000.000	200.5	H	214.0	37.1	14.4	84.4
5932.266667	71.5	1000.0	1000.000	125.7	H	330.0	39.2	9.9	84.4
11730.966666	75.4	1000.0	1000.000	200.5	H	284.0	44.6	4.0	84.4
17304.70000	79.1	1000.0	1000.000	203.5	H	261.0	49.9	5.3	84.4

Test Notes:



2.7.12 Test Results above 30 MHz (SP1)

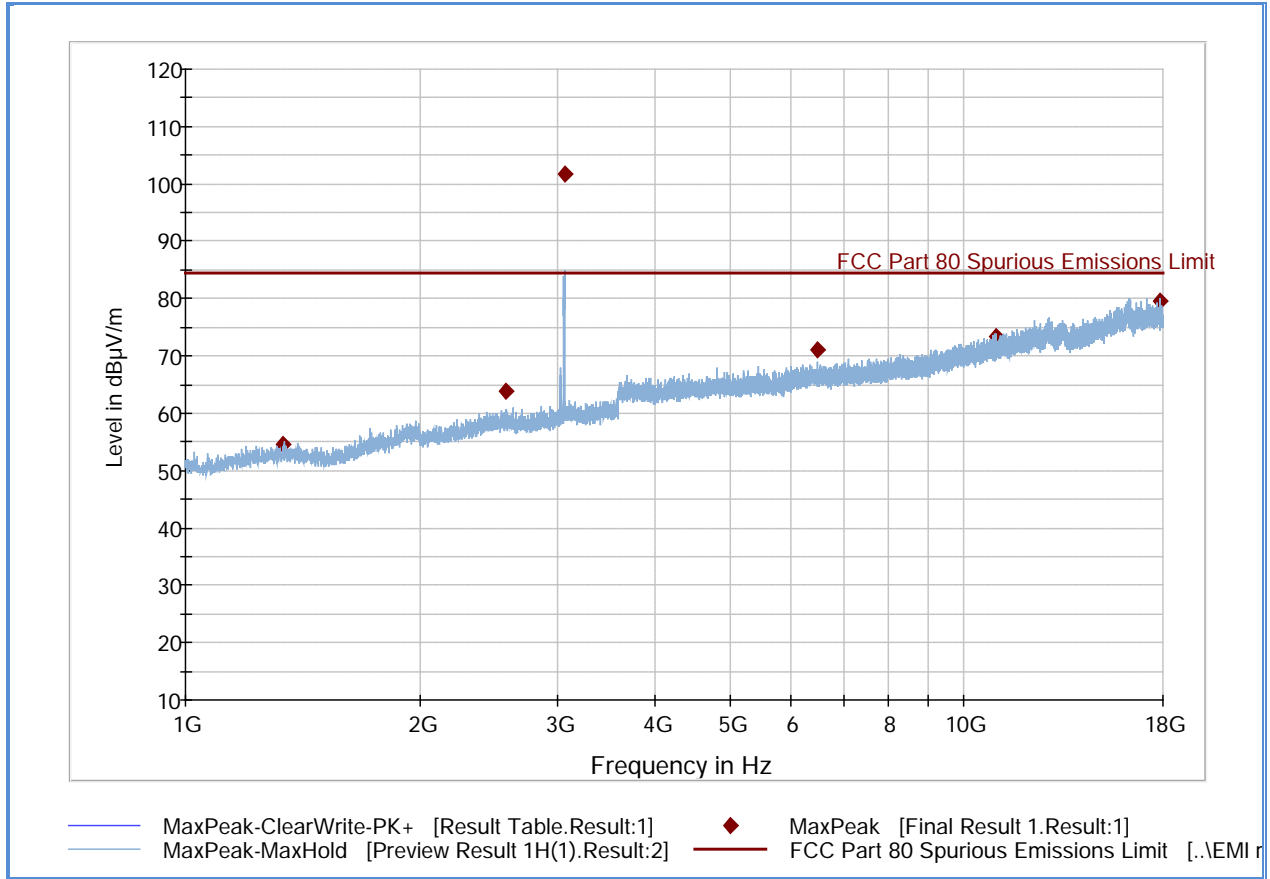

Peak Data

Frequency (MHz)	Peak (dBµV/m)	Meas. Time (ms)	Bandwidth (kHz)	Height (cm)	Polarization	Azimuth (deg)	Corr. (dB)	Margin (dB)	Limit (dBµV/m)
1334.133333	54.6	1000.0	1000.000	202.3	H	279.0	31.0	29.8	84.4
2577.733333	63.9	1000.0	1000.000	116.7	H	-20.0	35.4	20.5	84.4
3065.633333	101.8	1000.0	1000.000	206.5	H	94.0	35.9	Fundamental	
6483.066667	71.0	1000.0	1000.000	200.5	H	250.0	40.1	13.4	84.4
11008.16666	73.5	1000.0	1000.000	125.7	H	353.0	44.3	10.9	84.4
17864.16666	79.4	1000.0	1000.000	200.5	H	9.0	50.0	5.0	84.4

**Test Notes:** EUT transmitting to a load. No other emissions observed other than the fundamental frequency.





2.7.13 Test Results above 30 MHz (MP1)

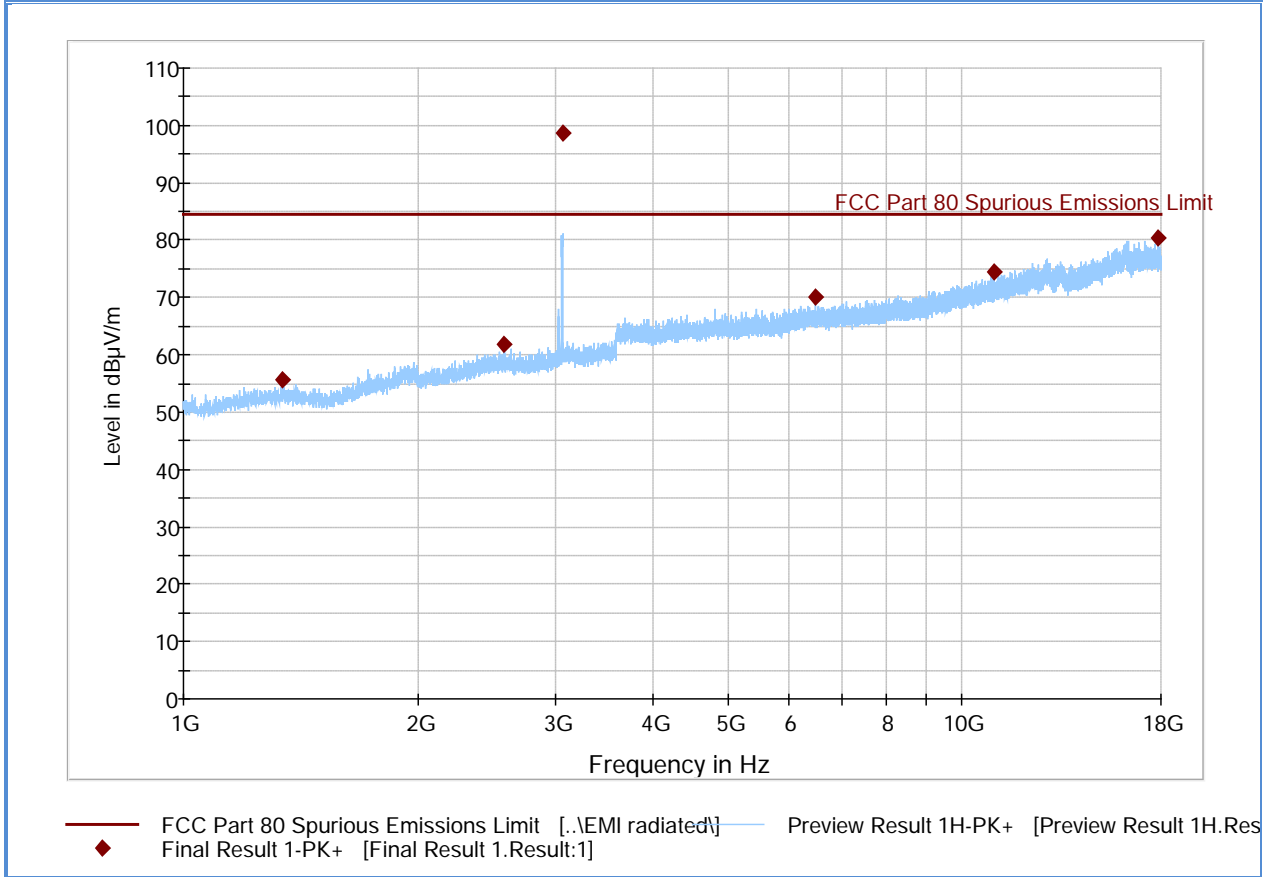

Peak Data

Frequency (MHz)	Peak (dBµV/m)	Meas. Time (ms)	Bandwidth (kHz)	Height (cm)	Polarization	Azimuth (deg)	Corr. (dB)	Margin (dB)	Limit (dBµV/m)
1337.133333	55.6	1000.0	1000.000	202.3	H	279.0	31.0	28.8	84.4
2579.733333	61.9	1000.0	1000.000	116.7	H	-20.0	35.4	22.5	84.4
3065.633333	98.8	1000.0	1000.000	206.5	H	94.0	35.9	Fundamental	
6482.066667	70.0	1000.0	1000.000	200.5	H	250.0	40.1	14.4	84.4
11010.166666	74.5	1000.0	1000.000	125.7	H	353.0	44.3	9.9	84.4
17874.166666	80.4	1000.0	1000.000	200.5	H	9.0	50.0	4.0	84.4

Test Notes: EUT transmitting to a load. No other emissions observed other than the fundamental frequency.



2.7.14 Test Results above 30 MHz (MP2)

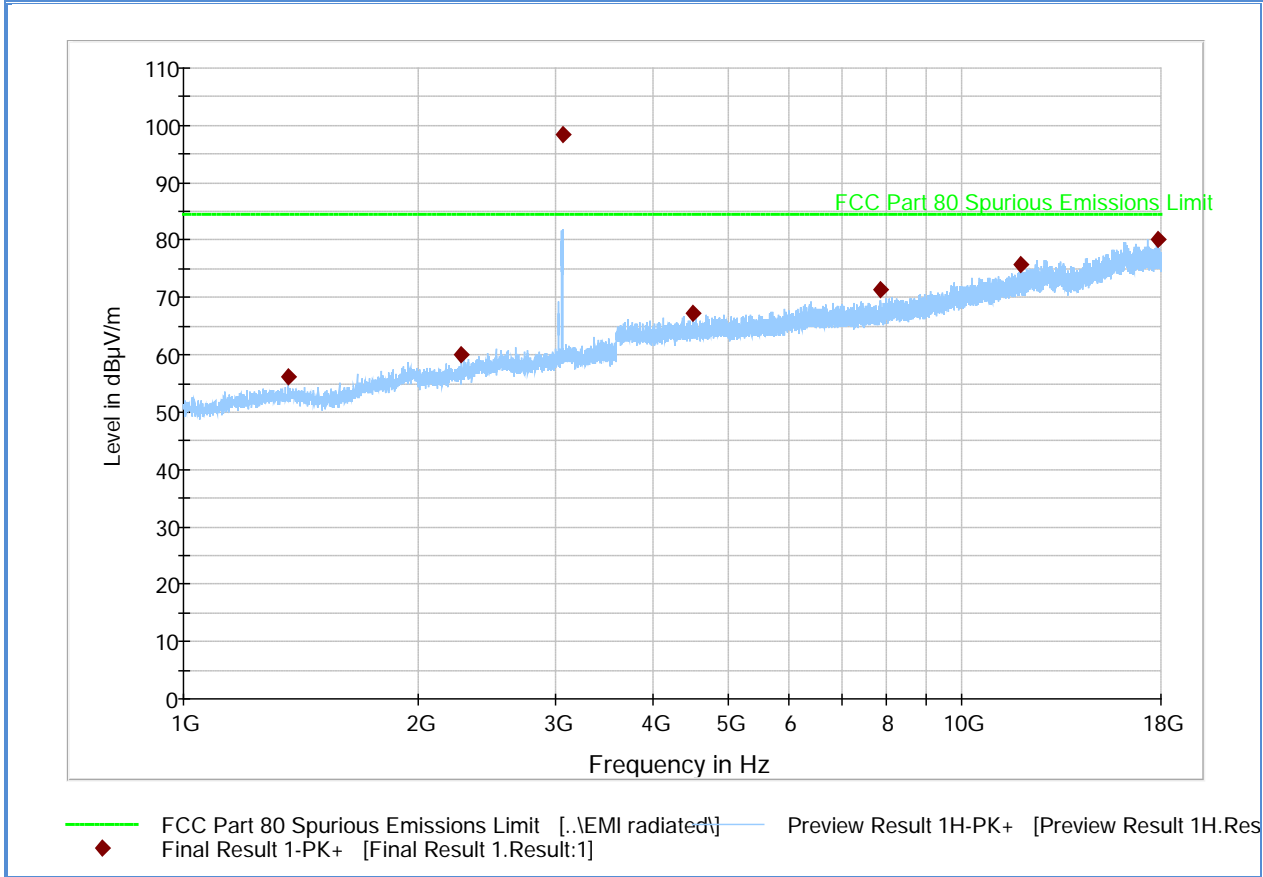

Peak Data

Frequency (MHz)	Peak (dBµV/m)	Meas. Time (ms)	Bandwidth (kHz)	Height (cm)	Polarization	Azimuth (deg)	Corr. (dB)	Margin (dB)	Limit (dBµV/m)
1366.300000	56.1	1000.0	1000.000	288.2	H	266.0	30.9	28.3	84.4
2277.066667	59.9	1000.0	1000.000	266.3	H	4.0	34.6	24.5	84.4
3065.900000	98.3	1000.0	1000.000	146.6	H	150.0	35.9	Fundamental	
4513.933333	67.3	1000.0	1000.000	102.7	H	16.0	37.7	17.1	84.4
7858.400000	71.4	1000.0	1000.000	165.6	H	337.0	40.9	13.0	84.4
11899.666666	75.7	1000.0	1000.000	202.3	H	95.0	45.1	8.7	84.4
17854.366666	80.1	1000.0	1000.000	103.7	H	154.0	50.0	4.3	84.4

**Test Notes:** EUT transmitting to a load. No other emissions observed other than the fundamental frequency.



2.7.15 Test Results above 30 MHz (LP1)

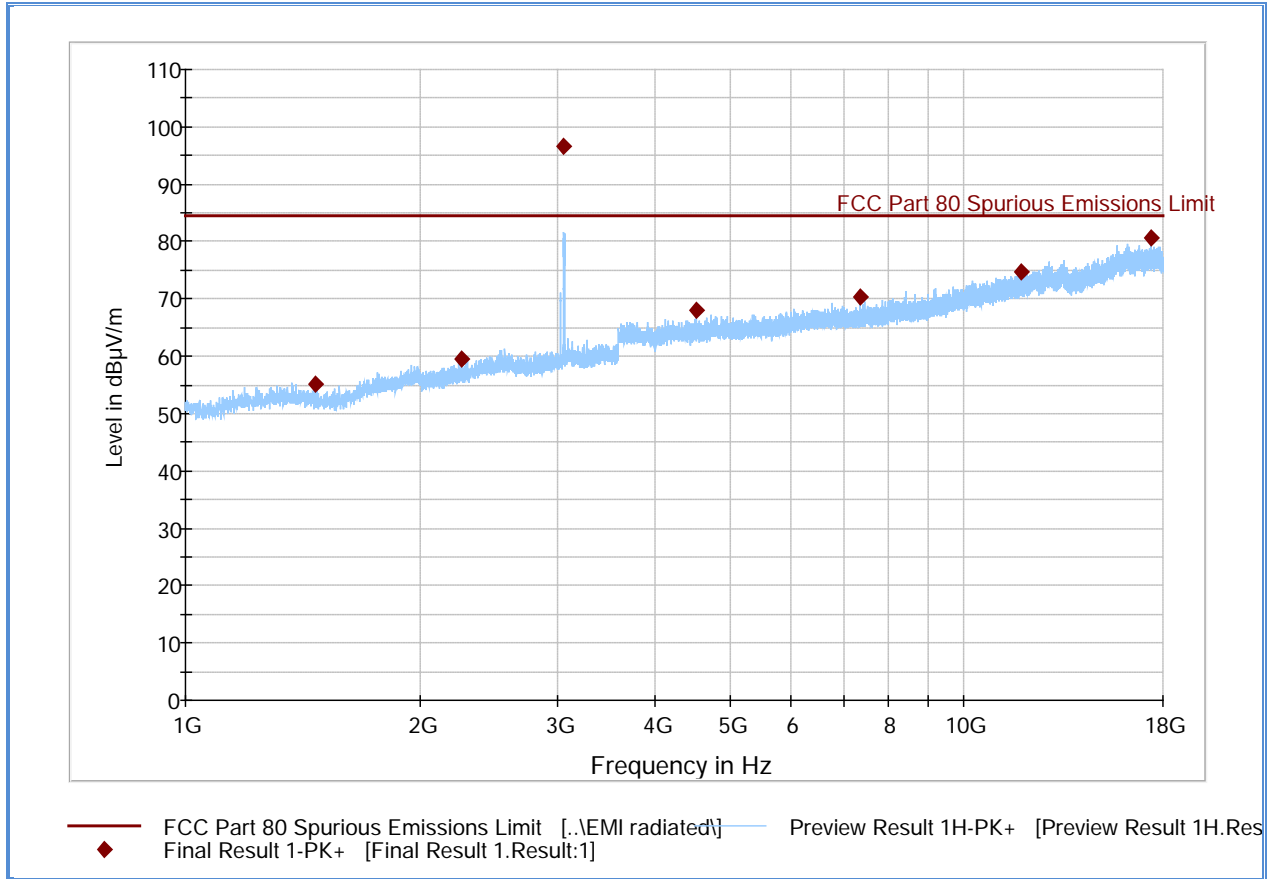

Peak Data

Frequency (MHz)	Peak (dBµV/m)	Meas. Time (ms)	Bandwidth (kHz)	Height (cm)	Polarization	Azimuth (deg)	Corr. (dB)	Margin (dB)	Limit (dBµV/m)
1469.766667	55.0	1000.0	1000.000	192.5	H	76.0	30.2	29.4	84.4
2261.800000	59.4	1000.0	1000.000	202.3	H	321.0	34.5	25.0	84.4
3063.766667	96.6	1000.0	1000.000	181.5	H	20.0	35.9	Fundamental	
4536.766667	67.9	1000.0	1000.000	115.7	H	149.0	37.8	16.5	84.4
7363.100000	70.4	1000.0	1000.000	267.3	H	-20.0	40.5	14.0	84.4
11845.066666	74.8	1000.0	1000.000	226.4	H	355.0	44.9	9.6	84.4
17345.733333	80.7	1000.0	1000.000	103.7	H	184.0	49.9	3.7	84.4

Test Notes: EUT transmitting to a load. No other emissions observed other than the fundamental frequency.



2.7.16 Test Results above 30 MHz (LP2)

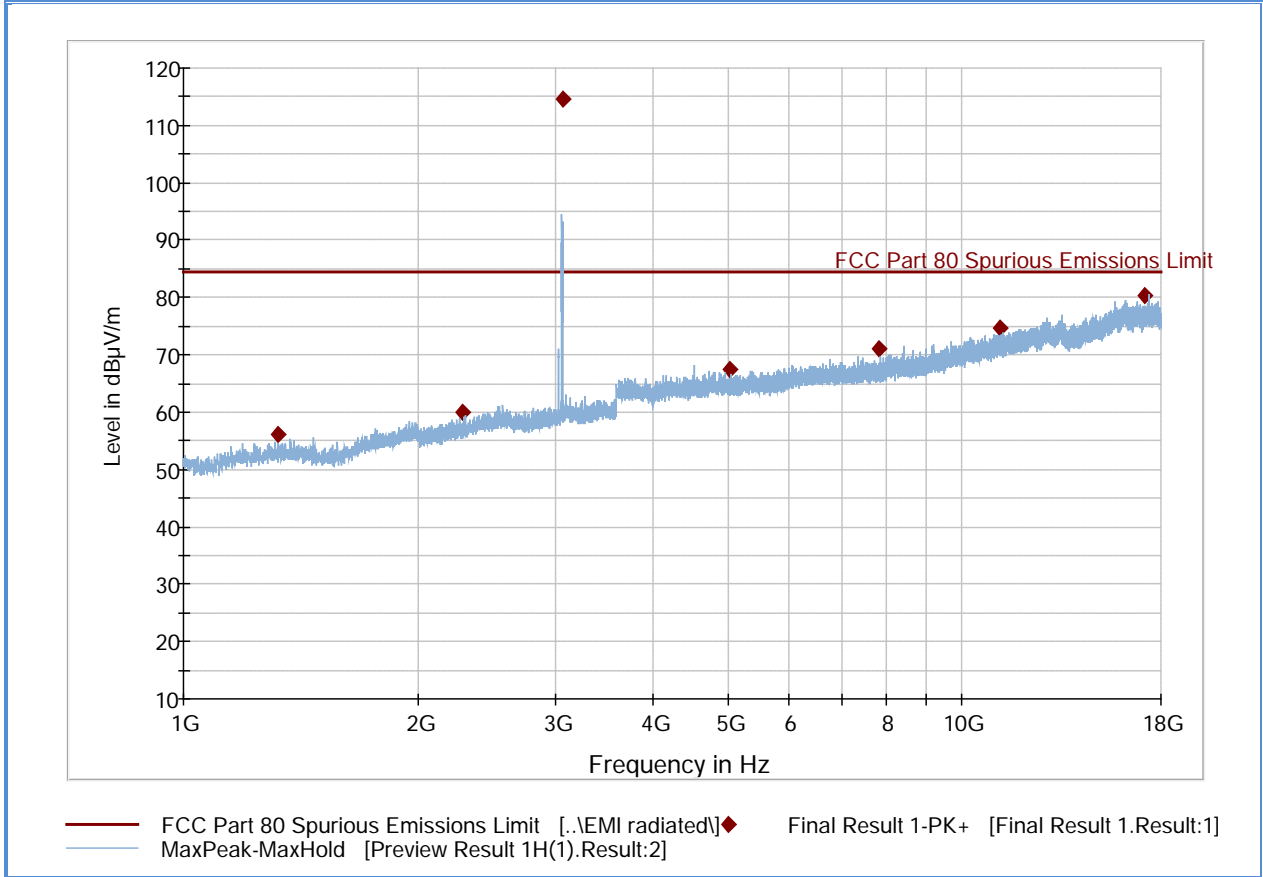

Peak Data

Frequency (MHz)	Peak (dBµV/m)	Meas. Time (ms)	Bandwidth (kHz)	Height (cm)	Polarization	Azimuth (deg)	Corr. (dB)	Margin (dB)	Limit (dBµV/m)
1321.533333	56.1	1000.0	1000.000	207.5	H	28.0	30.9	28.3	84.4
2277.400000	59.9	1000.0	1000.000	190.5	H	20.0	34.6	24.5	84.4
3067.033333	114.5	1000.0	1000.000	137.7	H	209.0	35.9	Fundamental	
5022.400000	67.5	1000.0	1000.000	115.7	H	238.0	38.1	16.9	84.4
7825.133333	71.1	1000.0	1000.000	133.7	H	279.0	40.9	13.3	84.4
11203.066666	74.5	1000.0	1000.000	180.6	H	254.0	44.3	9.9	84.4
17181.166666	80.4	1000.0	1000.000	183.5	H	0.0	49.7	4.0	84.4

Test Notes: EUT transmitting to a load. No other emissions observed other than the fundamental frequency.



### **SECTION 3**

#### **TEST EQUIPMENT USED**



### 3.1 TEST EQUIPMENT USED

List of absolute measuring and other principal items of test equipment.

ID Number (SDGE/SDRB)	Test Equipment	Type	Serial Number	Manufacturer	Cal Date	Cal Due Date
Antenna Conducted Port Setup						
7620	EMI Test Receiver	ESU40	100399	Rhode & Schwarz	09/03/15	09/03/16
7582	Signal/Spectrum Analyzer	FSW26	101614	Rhode & Schwarz	12/22/14	12/22/15
7608	Vector Signal Generator	SMBV100A	259021	Rhode & Schwarz	07/29/15	07/29/16
8773	10dB Attenuator	606-10-1F4/DR	N/A	Meca	Verified by 7582 and 7608	
Radiated Emissions						
7575	Double-ridged waveguide horn antenna	3117	00155511	EMCO	04/27/15	04/27/16
8628	Pre-amplifier	QLJ 01182835-JO	8986002	QuinStar Technologies Inc.	03/20/15	03/20/16
1153	High-frequency cable	SucoFlex 100 SX	N/A	Suhner	04/03/15	04/03/16
1051	Double-ridged waveguide horn antenna	3115	9408-4329	EMCO	02/28/14	02/28/16
1002	Bilog Antenna	3142C	00058717	ETS-Lindgren	01/30/14	01/30/16
1049	EMI Test Receiver	ESU	100133	Rhode & Schwarz	03/11/15	03/11/16
1016	Pre-amplifier	PAM-0202	187	PAM	12/10/14	12/10/15
Miscellaneous						
6792	Multimeter	3478A	2911A70964	Hewlett Packard	08/14/15	08/14/16
6610	Temperature/Humidity Chamber	SH-27C	09963481-S10746	Environtronics	01/23/15	01/23/16
	AC Power Source	EW801	972430001	Elgar	Verified by 6792	
	Test Software	EMC32	V8.53	Rhode & Schwarz	N/A	



### 3.2 MEASUREMENT UNCERTAINTY

For a 95% confidence level, the measurement uncertainties for defined systems are:

#### 3.2.1 Radiated Emission Measurements (Below 1GHz)

Contribution		Probability Distribution Type	Probability Distribution $x_i$	Standard Uncertainty $u(x_i)$	$[u(x_i)]^2$
1	Receiver/Spectrum Analyzer	Rectangular	0.45	0.26	0.07
2	Cables	Rectangular	0.50	0.29	0.08
3	Preamp	Rectangular	0.50	0.29	0.08
4	Antenna	Rectangular	0.75	0.43	0.19
5	Site	Rectangular	3.89	2.25	5.04
6	EUT Setup	Rectangular	1.00	0.58	0.33
Combined Uncertainty ( $u_c$ ):					2.41
Coverage Factor (k):					2
Expanded Uncertainty:					4.82

#### 3.2.2 Radiated Emission Measurements (Above 1GHz)

Contribution		Probability Distribution Type	Probability Distribution $x_i$	Standard Uncertainty $u(x_i)$	$[u(x_i)]^2$
1	Receiver/Spectrum Analyzer	Rectangular	0.57	0.33	0.11
2	Cables	Rectangular	0.70	0.40	0.16
3	Preamp	Rectangular	0.50	0.29	0.08
4	Antenna	Rectangular	0.37	0.21	0.05
5	Site	Rectangular	3.89	2.25	5.04
6	EUT Setup	Rectangular	1.00	0.58	0.33
Combined Uncertainty ( $u_c$ ):					2.40
Coverage Factor (k):					2
Expanded Uncertainty:					4.81

#### 3.2.3 Conducted Antenna Port Measurement

Contribution		Probability Distribution Type	Probability Distribution $x_i$	Standard Uncertainty $u(x_i)$	$[u(x_i)]^2$
1	Receiver/Spectrum Analyzer	Rectangular	0.34	0.20	0.04
2	Cables	Rectangular	1.00	0.58	0.33
3	EUT Setup	Rectangular	0.50	0.29	0.08
Combined Uncertainty ( $u_c$ ):					0.67
Coverage Factor (k):					1.96
Expanded Uncertainty:					1.32



## SECTION 4

### DIAGRAM OF TEST SETUP



4.1 TEST SETUP DIAGRAM

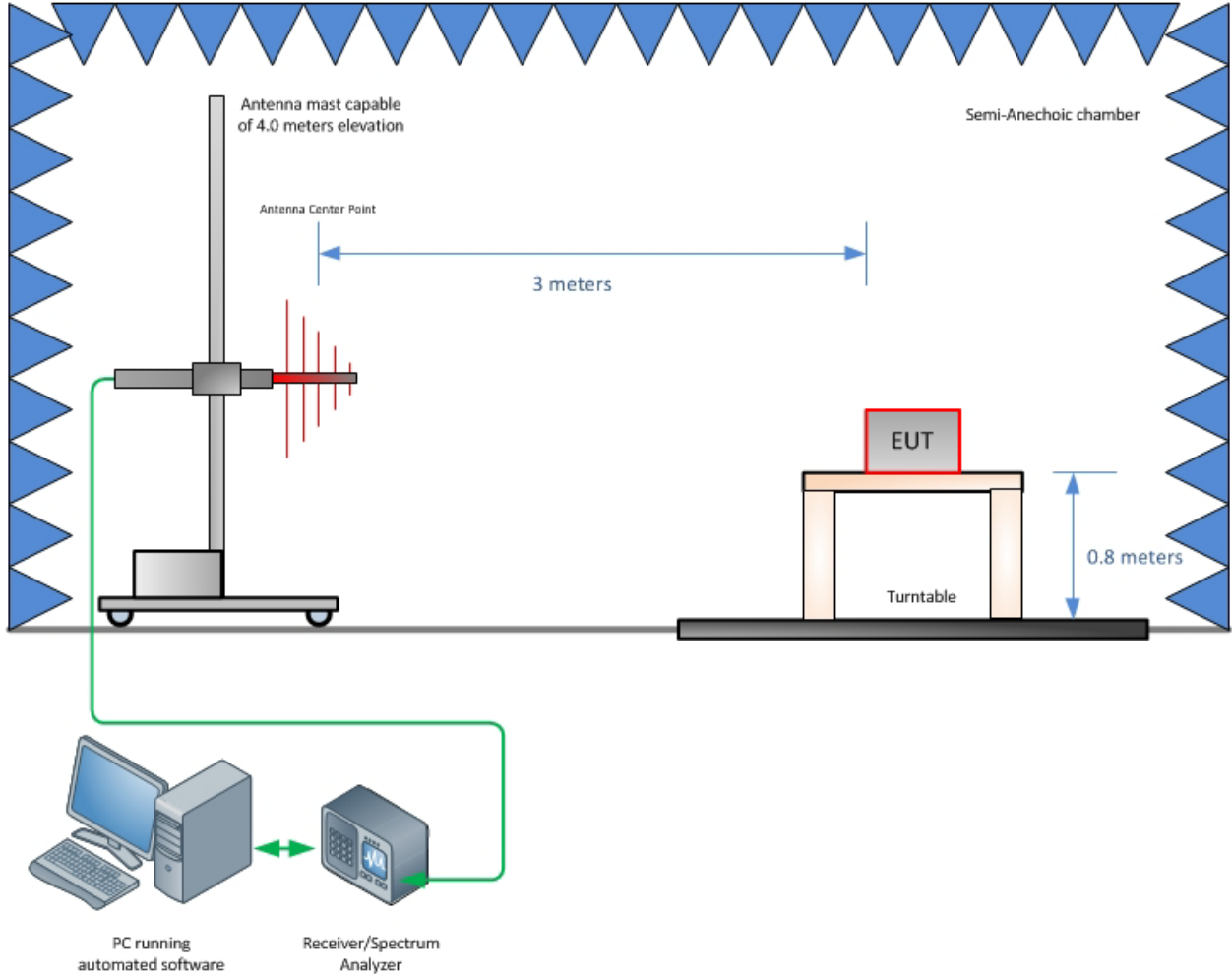

**Radiated Emission Test Setup (Below 1GHz)**

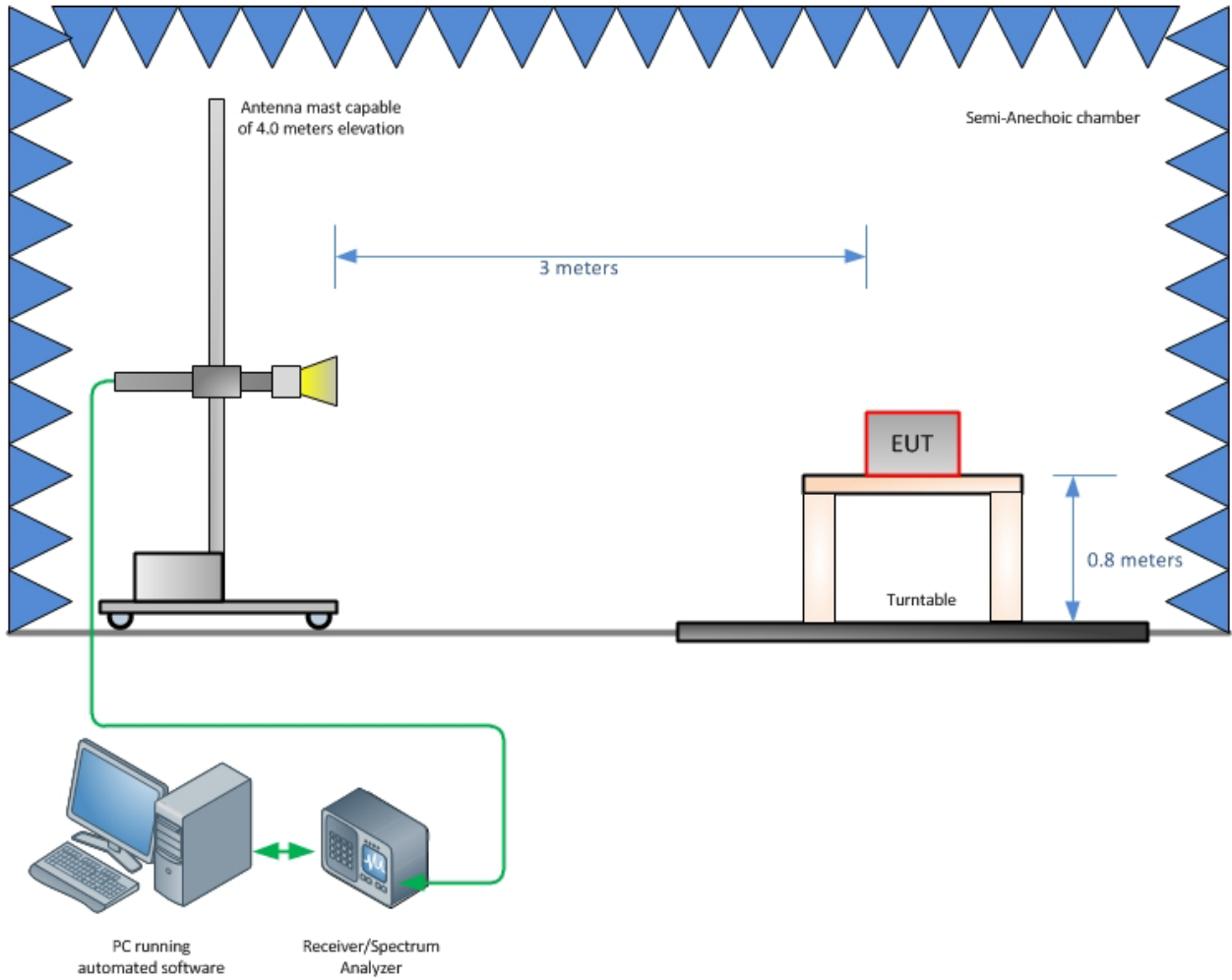

**Radiated Emission Test Setup (Above 1GHz)**

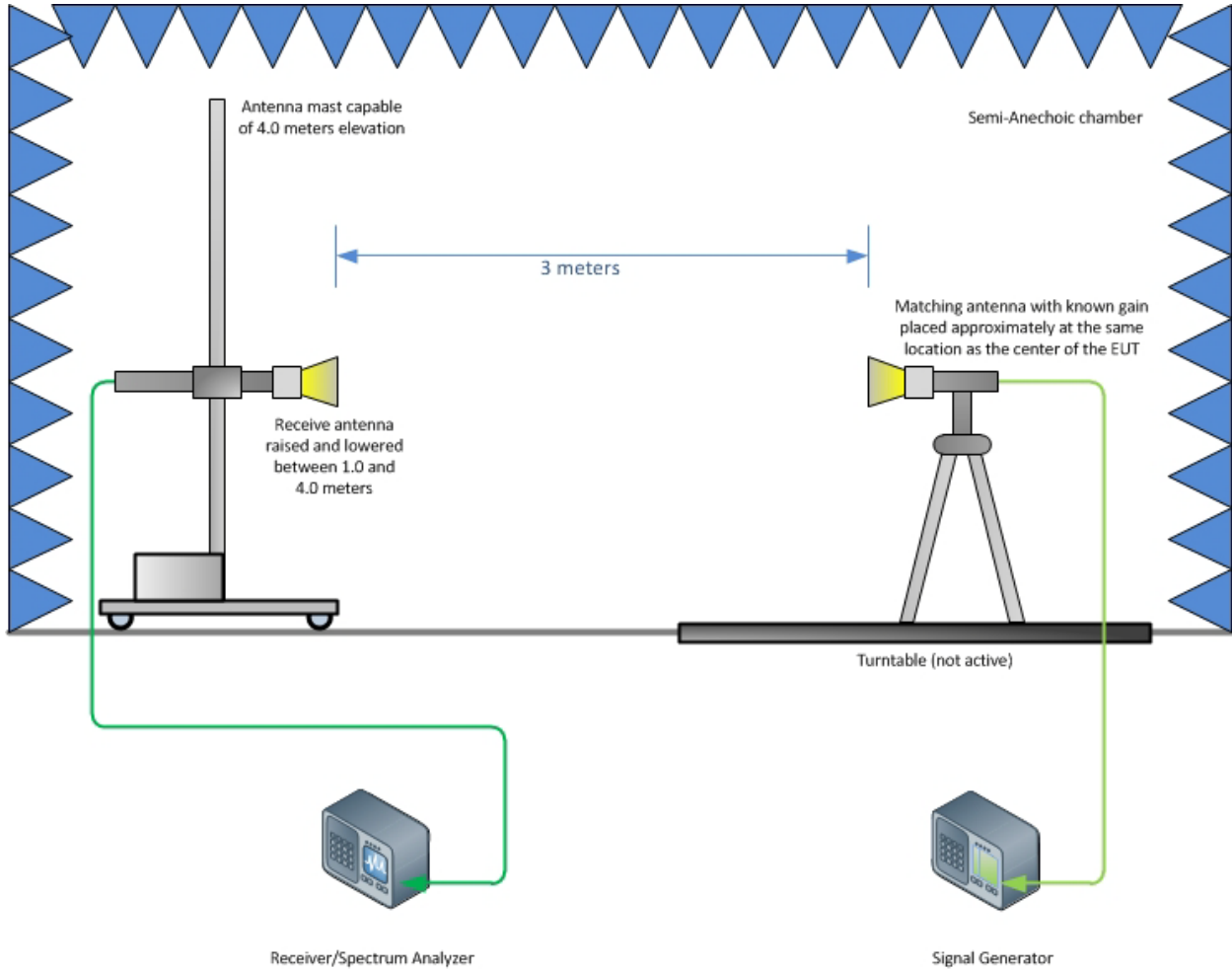

**Substitution Test Method (Above 1GHz)**

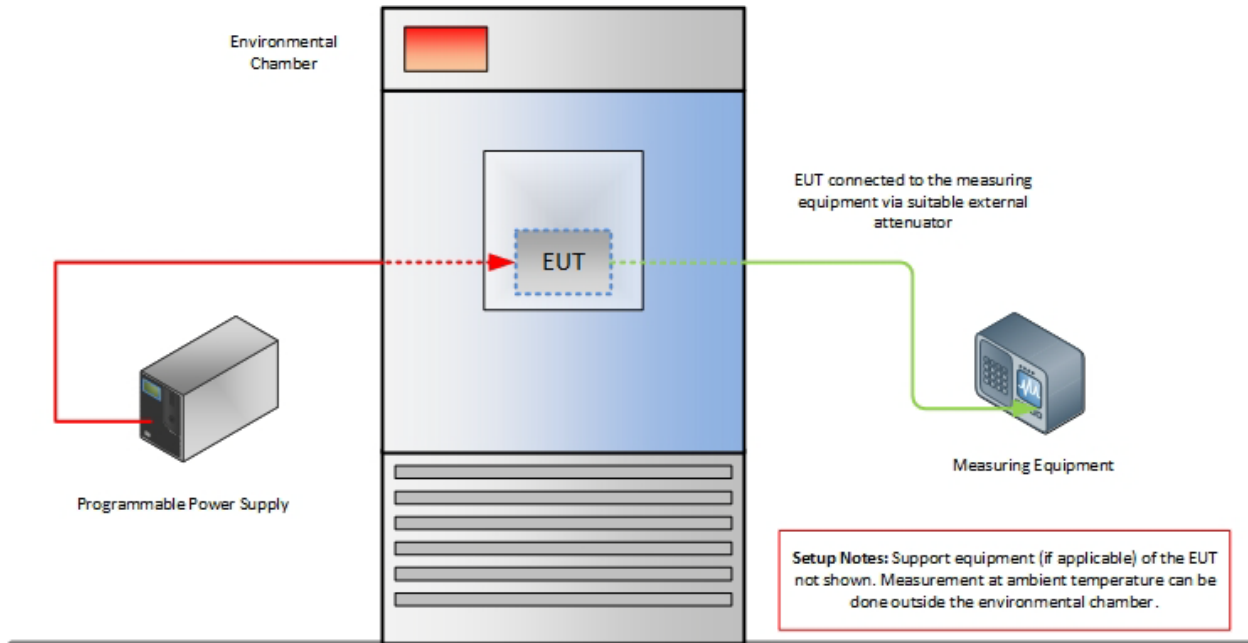

**Frequency Stability Test Configuration**



## SECTION 5

### ACCREDITATION, DISCLAIMERS AND COPYRIGHT



5.1 **ACCREDITATION, DISCLAIMERS AND COPYRIGHT**

TÜV SÜD America Inc.'s reports apply only to the specific sample tested under stated test conditions. It is the manufacturer's responsibility to assure the continued compliance of production units of this model. TÜV SÜD America, Inc. shall have no liability for any deductions, inferences or generalizations drawn by the client or others from TÜV SÜD America, Inc.'s issued reports.

This report is the confidential property of the client. As a mutual protection to our clients, the public and TÜV SÜD America, Inc., extracts from the test report shall not be reproduced, except in full without TÜV SÜD America, Inc.'s written approval.

This report must not be used to claim product certification, approval, or endorsement by A2LA, NIST, or any agency of the federal government.

TÜV SÜD America, Inc. and its professional staff hold government and professional organization certifications for AAMI, ACIL, AEA, ANSI, IEEE, A2LA, NIST and VCCI.



A2LA Cert. No. 2955.13

