

[Fig. 101 INTERCONNECTION DIAGRAM OF JMA-5104]

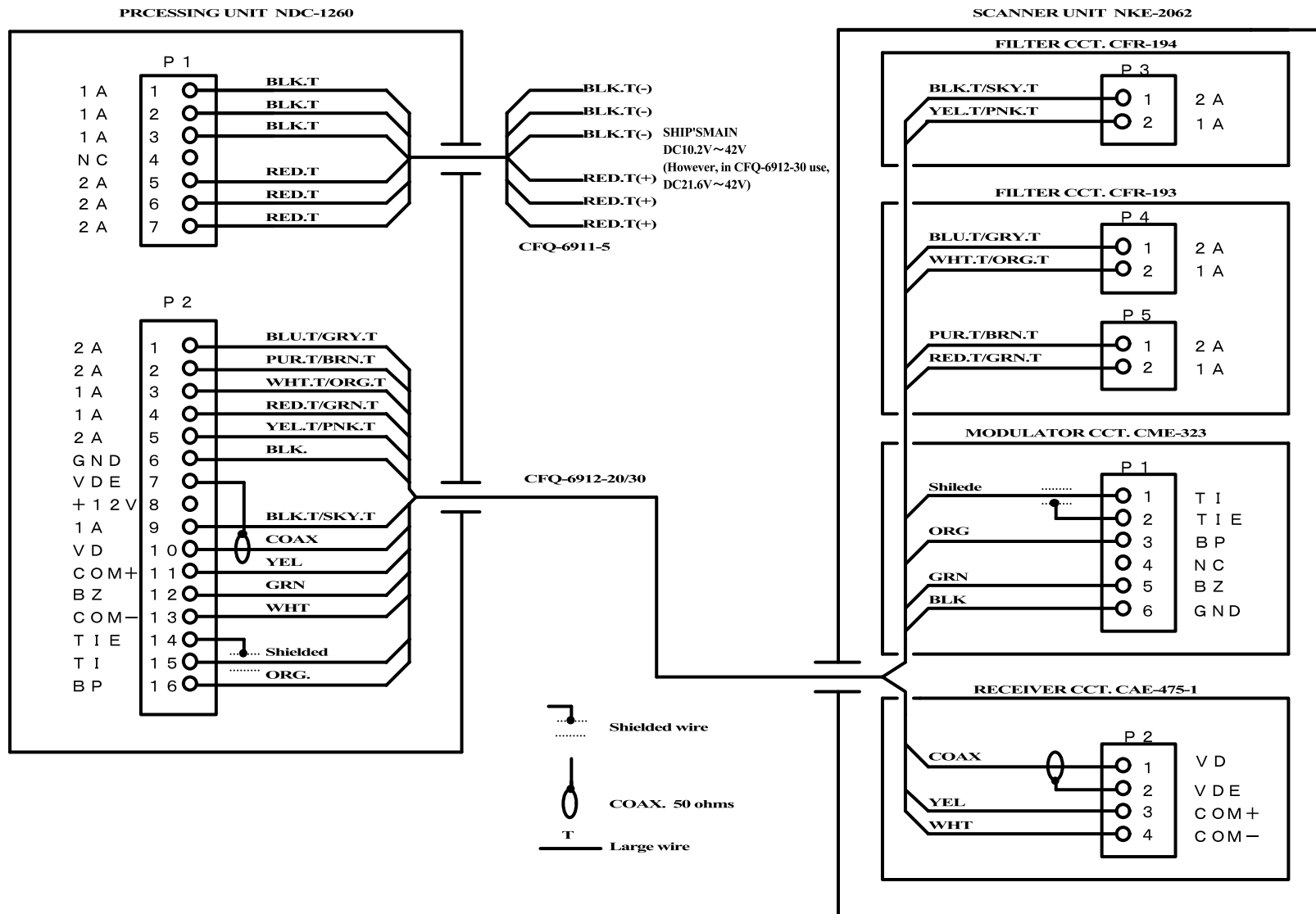

[Fig. 102 INTERCONNECTION DIAGRAM OF JMA-5106]

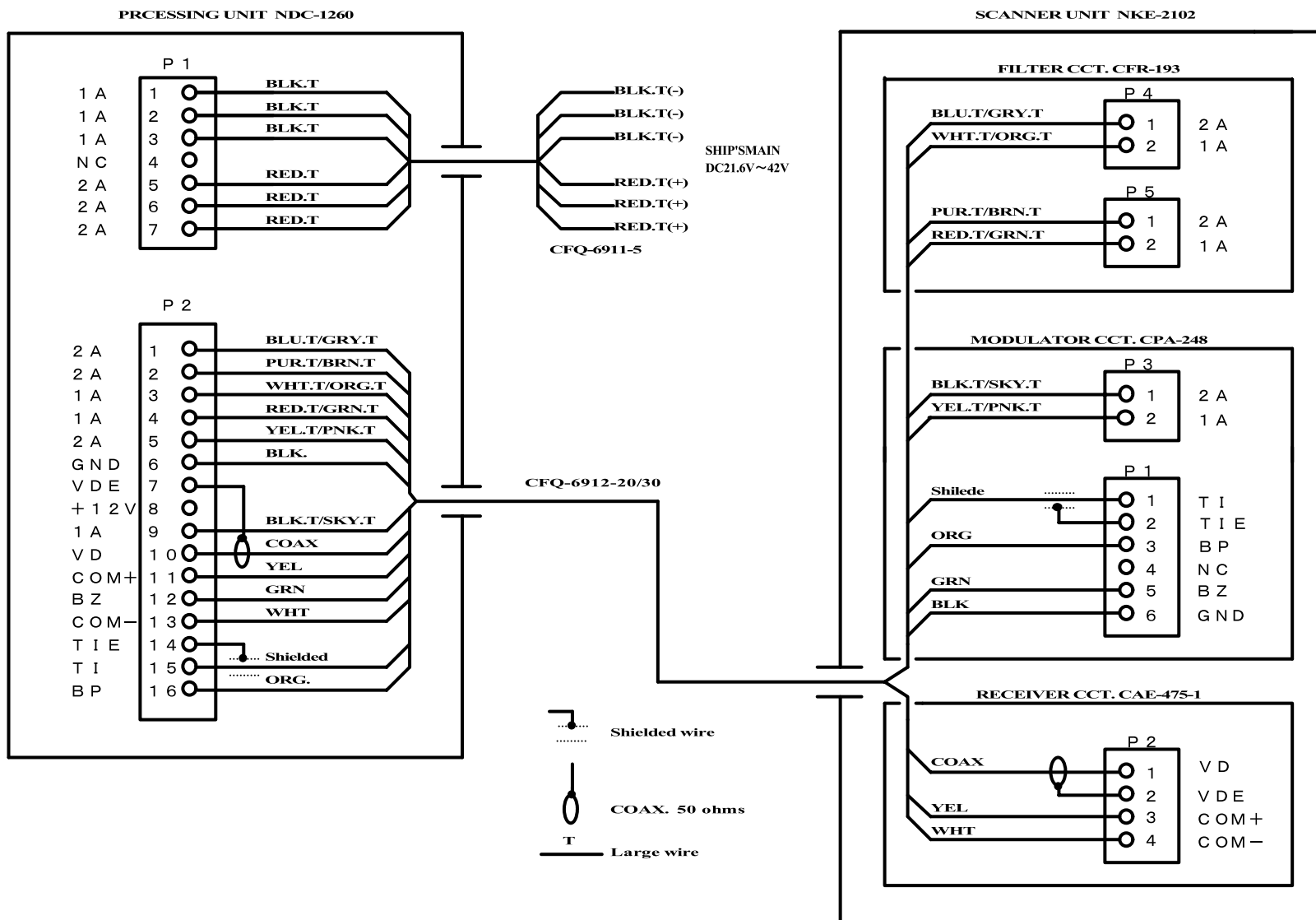

[Fig. 103 INTERCONNECTION DIAGRAM OF JMA-5110]

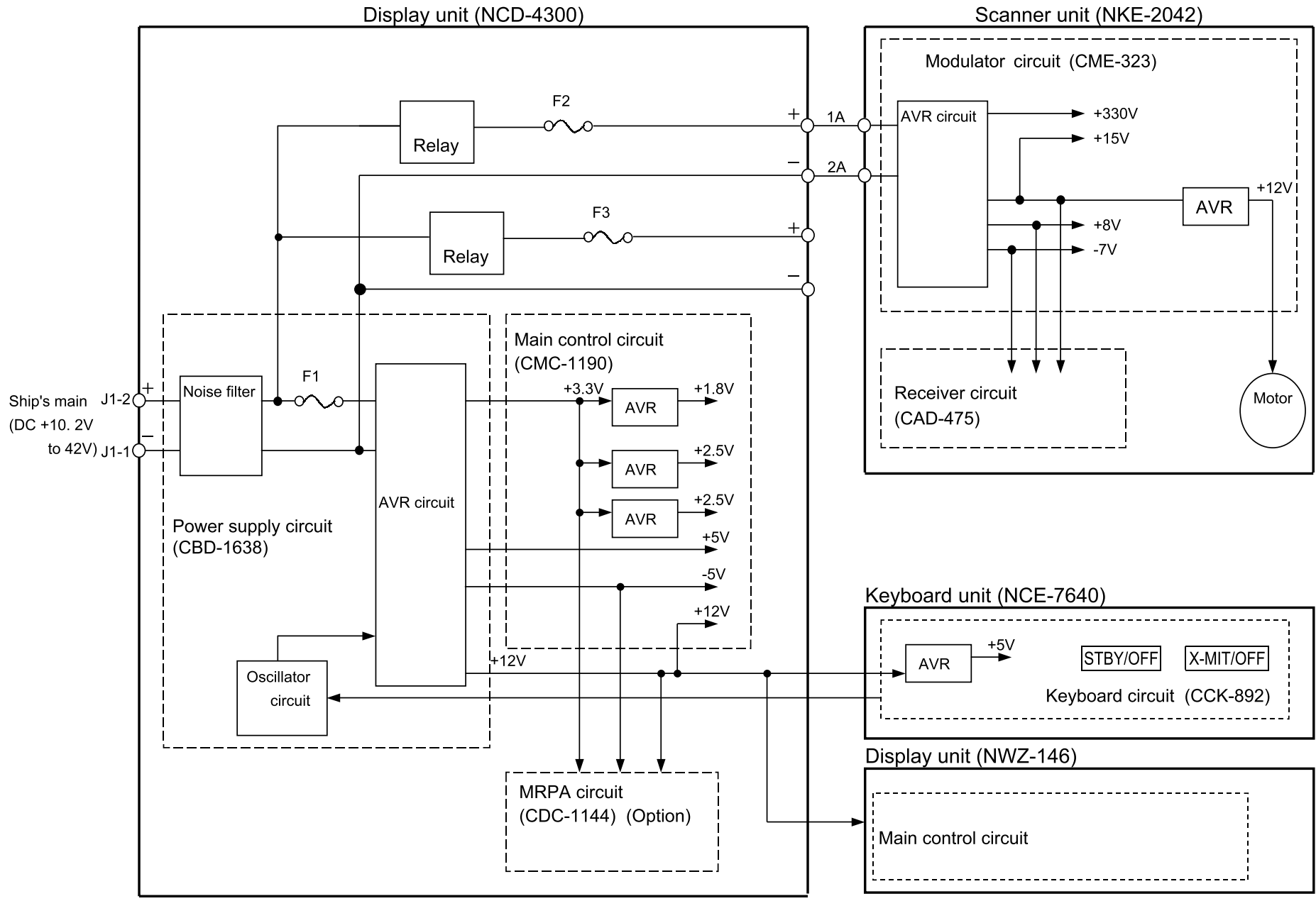

[Fig. 104. PRIMARY POWER SYSTEM DIAGRAM OF JMA-5104]

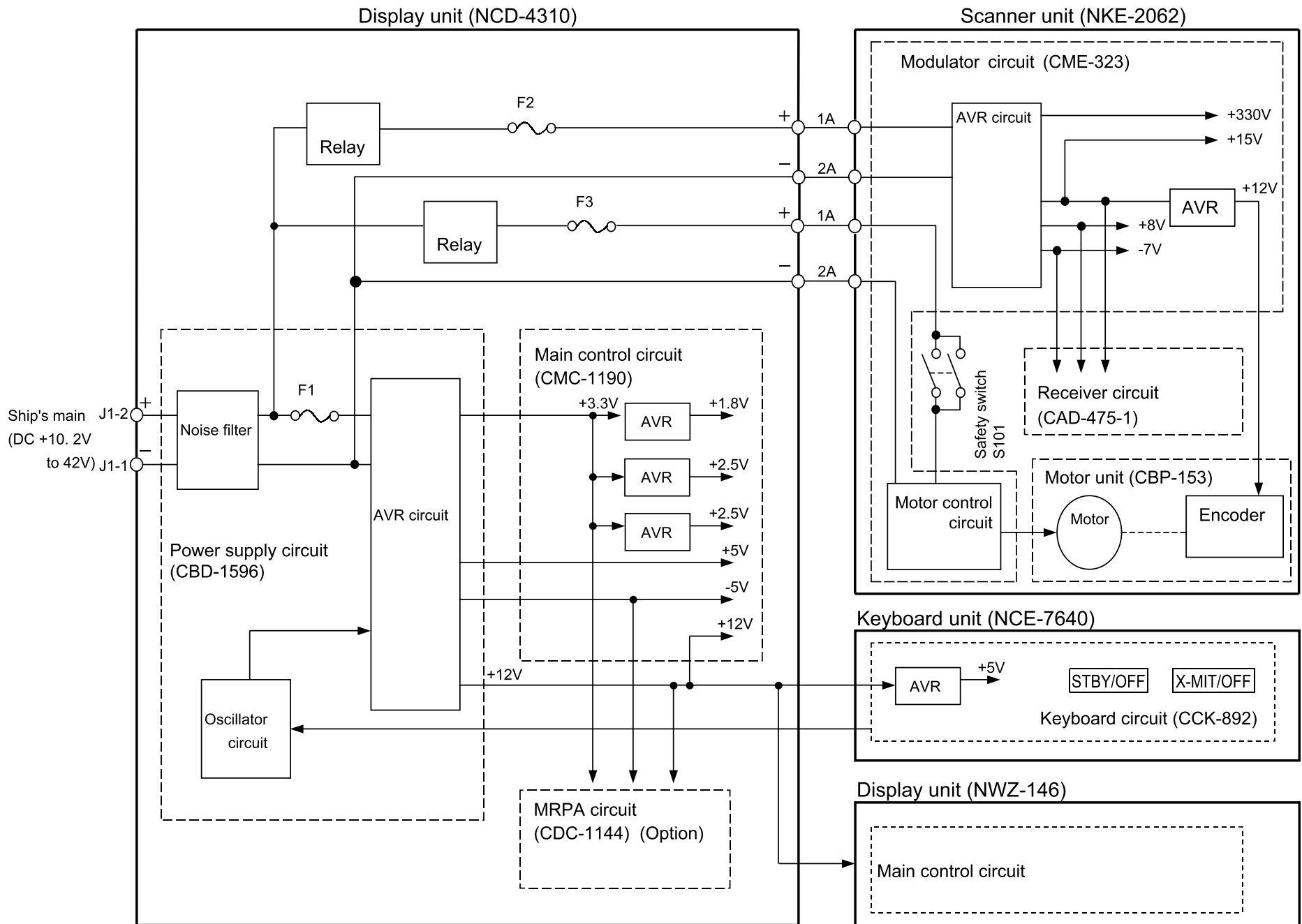

[Fig. 105 PRIMARY POWER SYSTEM DIAGRAM OF JMA-5106]

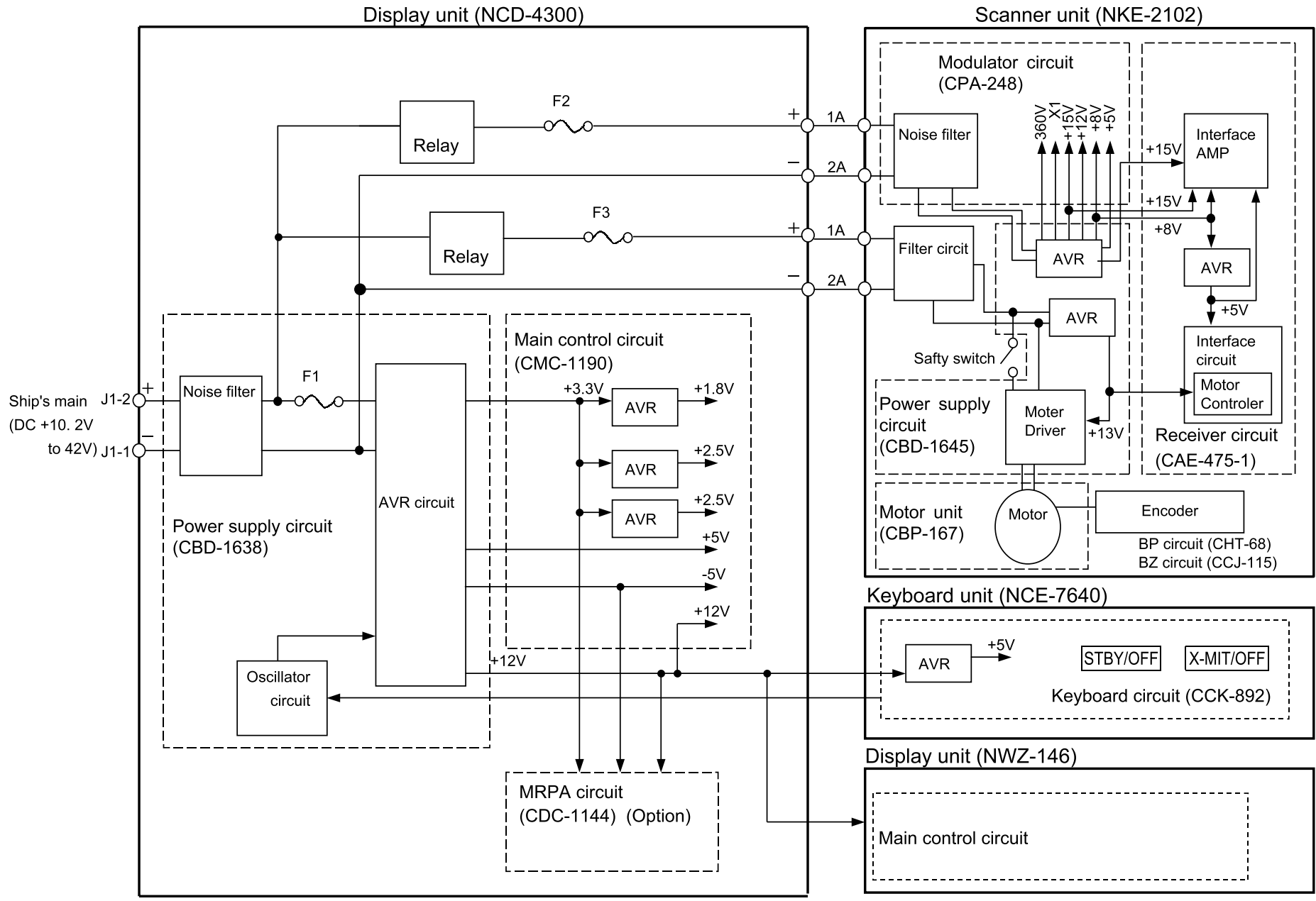

[Fig. 106 PRIMARY POWER SYSTEM DIAGRAM OF JMA-5110]

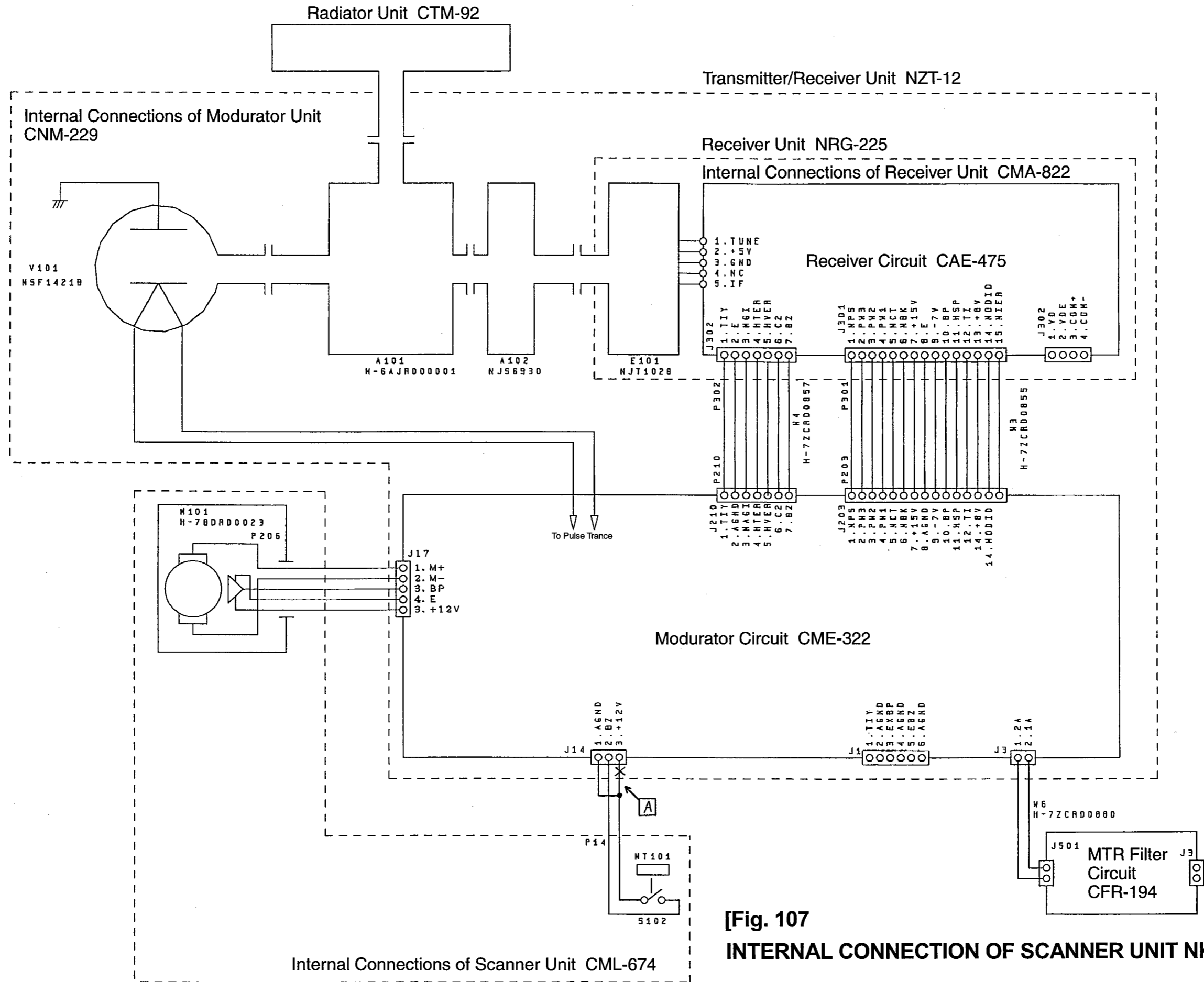

**[Fig. 107  
INTERNAL CONNECTION OF SCANNER UNIT NKE-2042]**

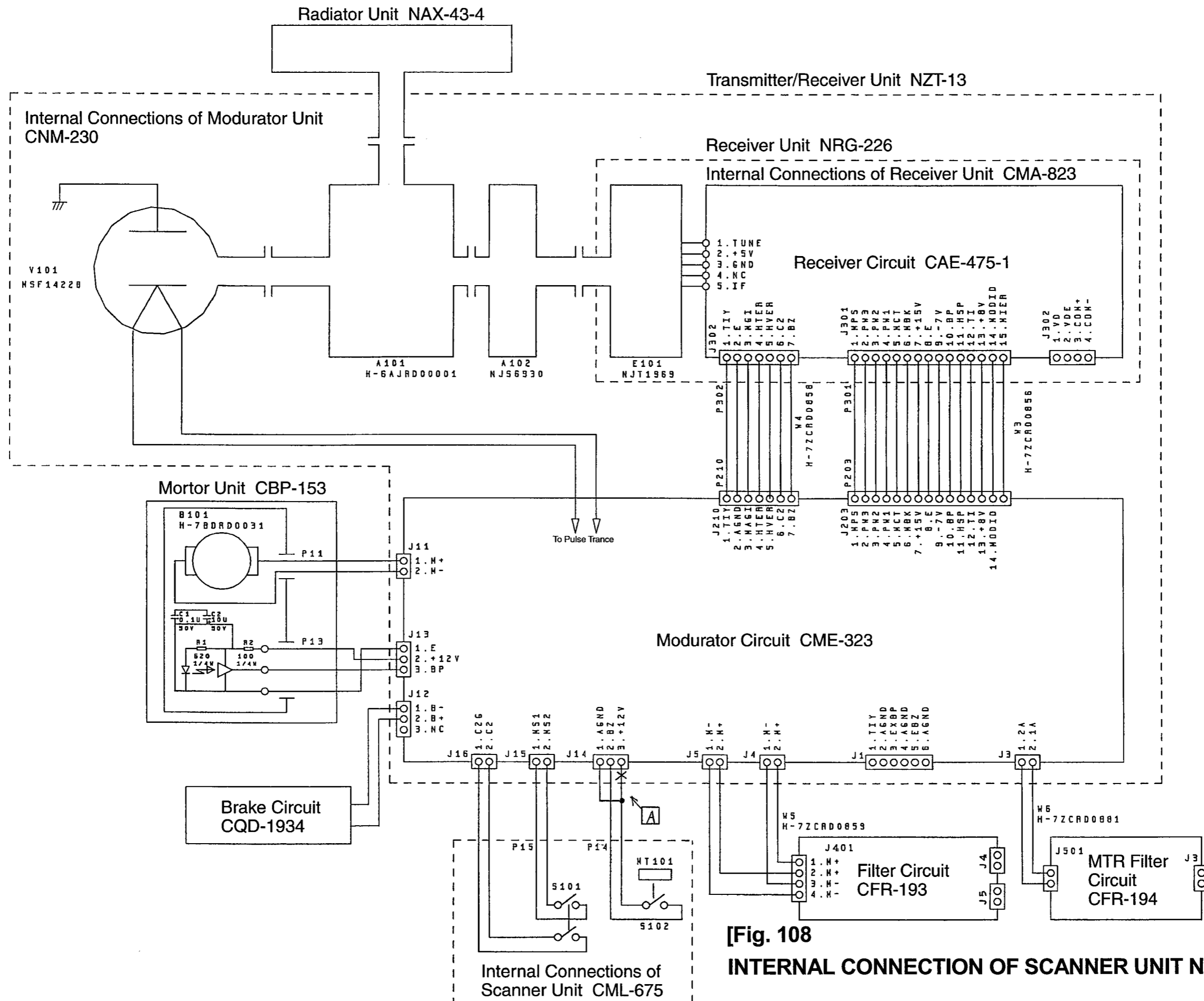

**[Fig. 108  
INTERNAL CONNECTION OF SCANNER UNIT NKE-2062]**



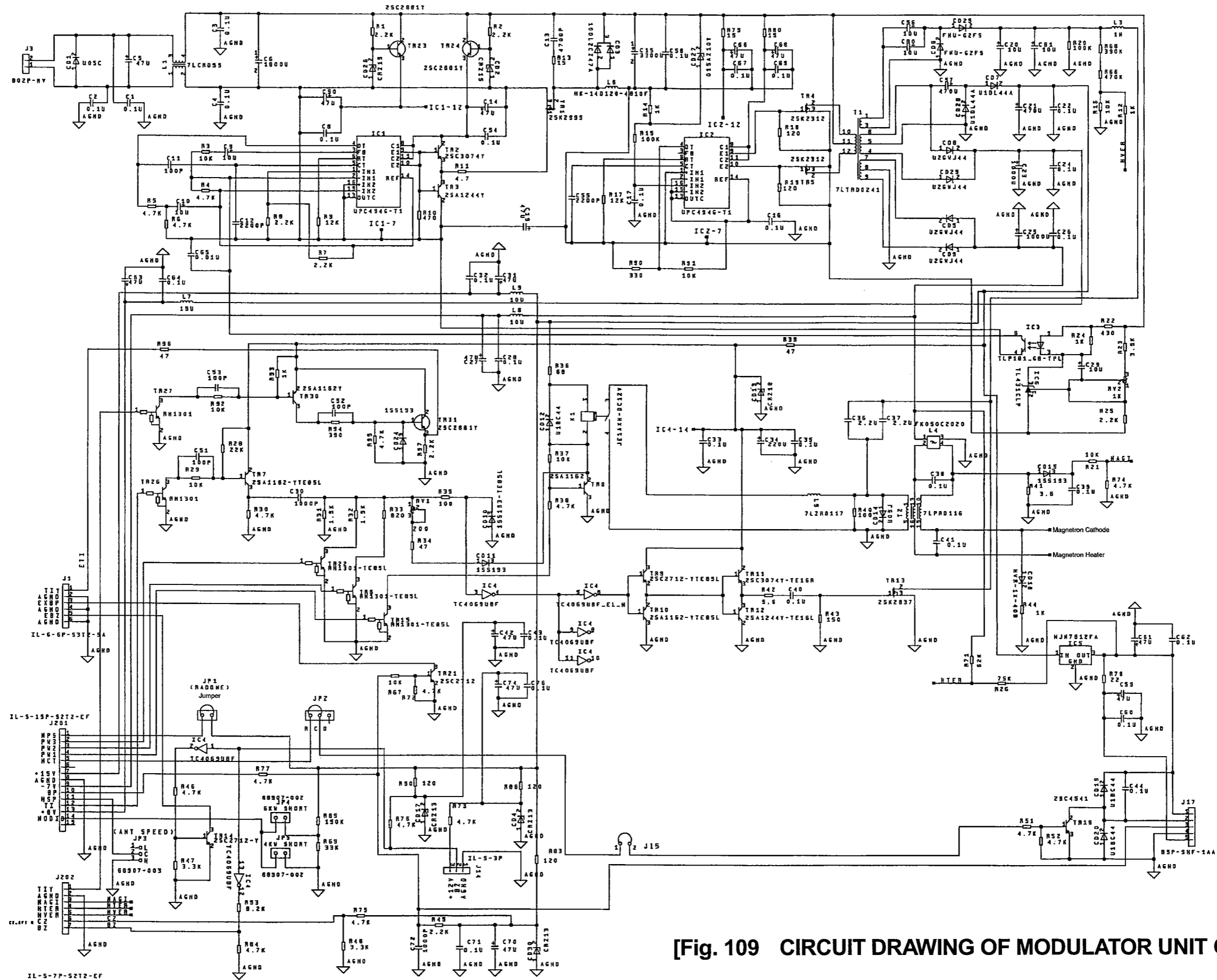

[Fig. 109 CIRCUIT DRAWING OF MODULATOR UNIT CME-322]

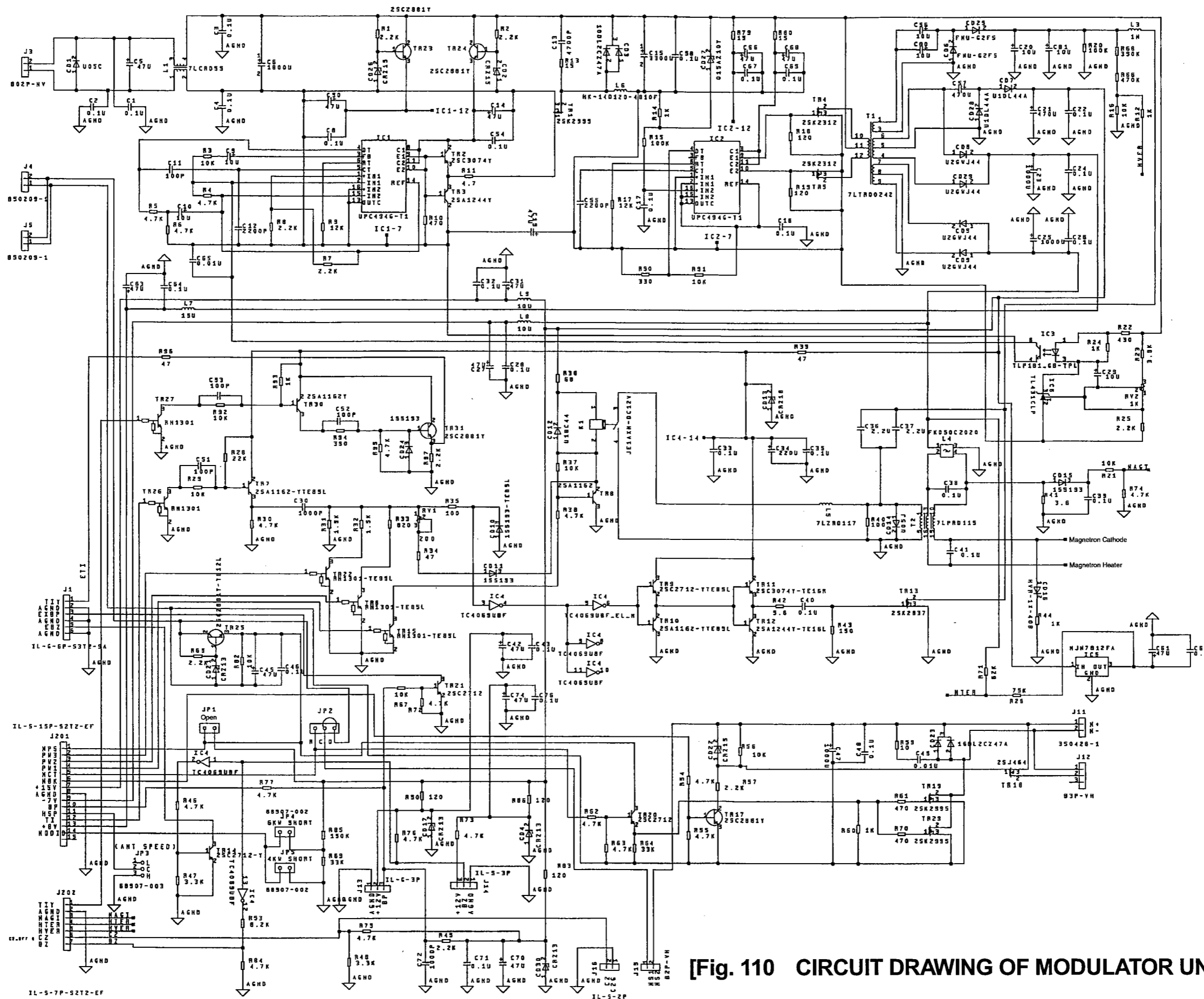

[Fig. 110] CIRCUIT DRAWING OF MODULATOR UNIT CME-323

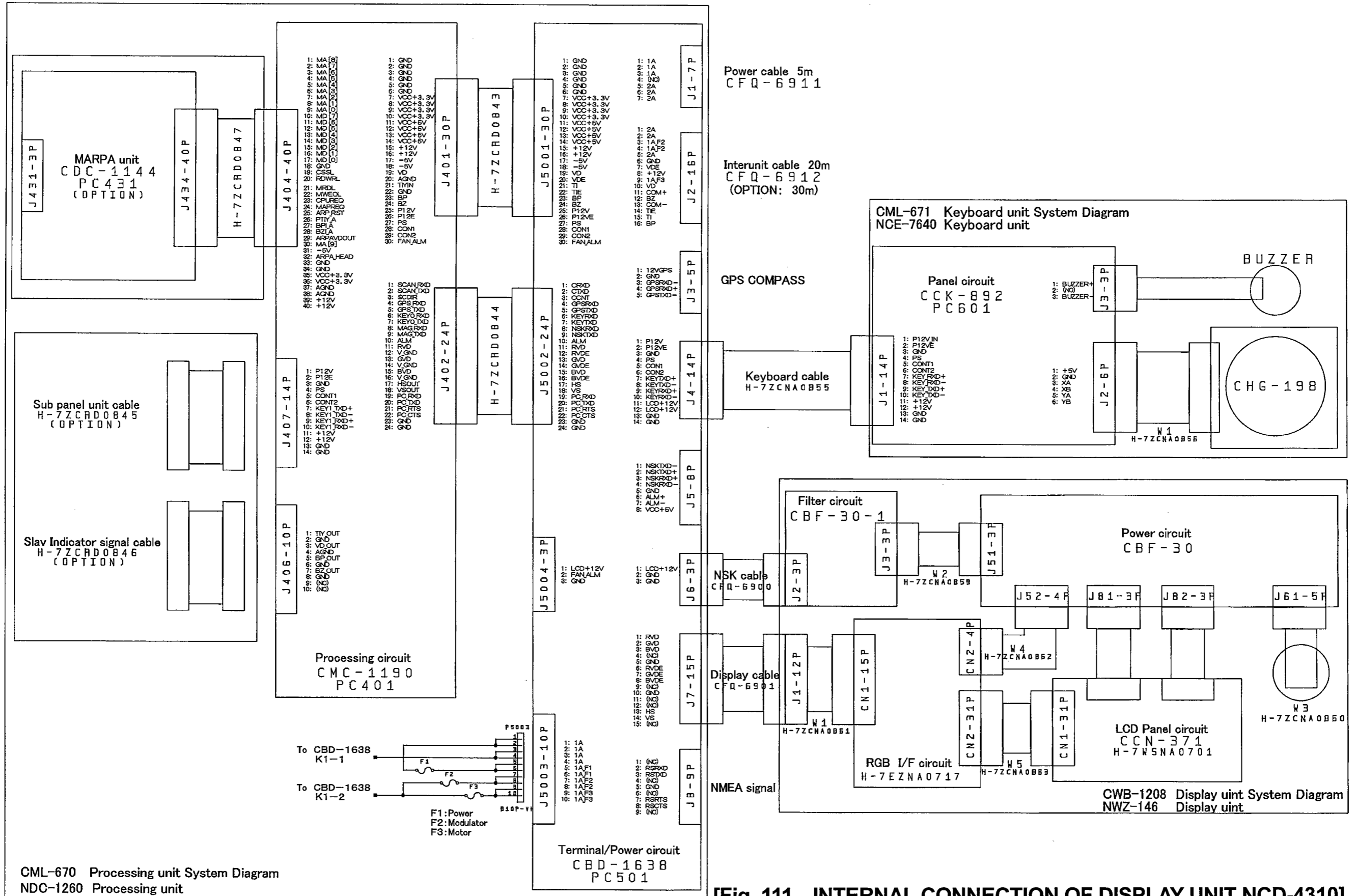

CML-670 Processing unit System Diagram  
NDC-1260 Processing unit

[Fig. 111 INTERNAL CONNECTION OF DISPLAY UNIT NCD-4310]

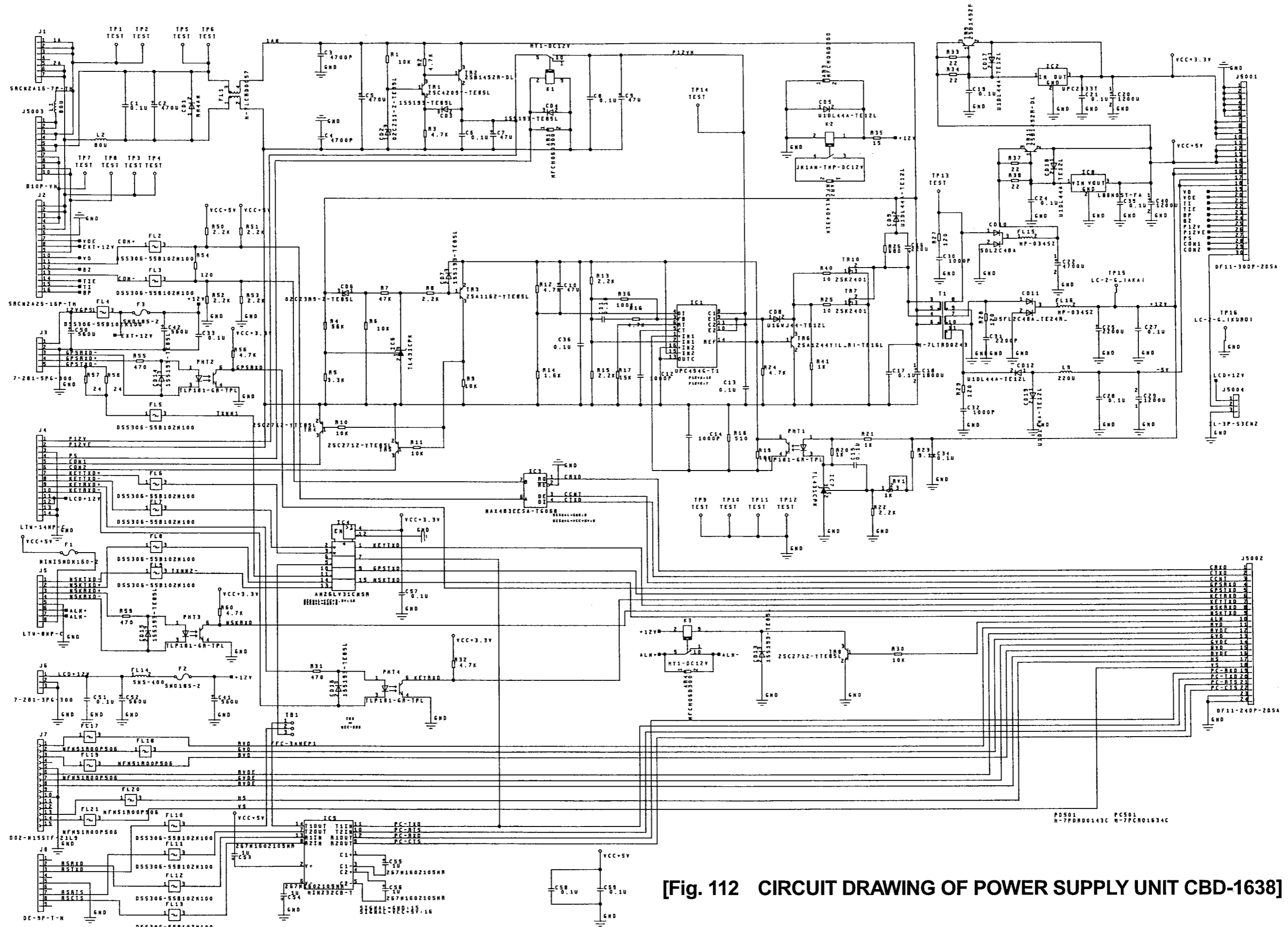

[Fig. 112 CIRCUIT DRAWING OF POWER SUPPLY UNIT CBD-1638]