

Declaration of conformity to FCC Part 80 for Marine Radar

FCC ID: CKENKE2043

We: Japan Radio Company Limited

declare under our sole responsibility that the CKENKE2043 scanner unit
conforms to the CFR part 80 rules for Marine Radars

Signed: H. Nakamura Date: 12th January, 2012

Mr. N. Hiroshi
Manager of Radar Group
Engineering Department
Marine Electronics Division

Signed: G. Higuchi

G. Higuchi
Radar Group
Engineering Department
Marine Electronics Division

3. TEST RESULTS SUMMARY

3.1 Mechanical Tests

Appearance and Structure

Scanner Unit Good

3.2 Electrical Tests

3.2.1 Working of each operation unit

Scanner Unit Good

3.2.2 Scanner

VSWR	frequency (MHz)	VSWR
	9380	1.02
	9410	1.03
	9440	1.04

Scanner Rotation Speed 16, 20, 24, 27, 30, 36, 42 and 48rpm

3.2.3 Transmitter

Magnetron Ser. No. SJ1B/T0802C

Operating Frequency

(at 0.08us / 4000Hz pulse, SP1)	9409.3MHz
(at 0.08us / 2250Hz pulse, SP2)	9411.3 MHz
(at 0.13us / 1700Hz pulse, SP3)	9409.3 MHz
(at 0.25us / 1700Hz pulse, MP1)	9409.3 MHz
(at 0.50us / 1200Hz pulse, MP2)	9409.3 MHz
(at 0.80us / 750Hz pulse, LP1)	9408.7 MHz
(at 1.0us / 650Hz pulse, LP2)	9408.7 MHz

RF power output

(at 0.08us / 4000Hz pulse, SP1)	0.12kW
(at 0.08us / 2250Hz pulse, SP2)	0.14kW
(at 0.13us / 1700Hz pulse, SP3)	0.32kW
(at 0.25us / 1700Hz pulse, MP1)	0.78kW
(at 0.50us / 1200Hz pulse, MP2)	2.37kW
(at 0.80us / 750Hz pulse, LP1)	3.94kW
(at 1.0us / 650Hz pulse, LP2)	3.61kW

Pulse Length

(at 0.08us / 4000Hz pulse, SP1)	0.070us
(at 0.08us / 2250Hz pulse, SP2)	0.072us
(at 0.13us / 1700Hz pulse, SP3)	0.13us
(at 0.25us / 1700Hz pulse, MP1)	0.23us
(at 0.50us / 1200Hz pulse, MP2)	0.49us

(at 0.80us / 750Hz pulse, LP1)	0.80us
(at 1.0us / 650Hz pulse, LP2)	0.99us

Repetition Frequency

(at 0.08us / 4000Hz pulse, SP1)	4006Hz
(at 0.08us / 2250Hz pulse, SP2)	2246Hz
(at 0.13us / 1700Hz pulse, SP3)	1700Hz
(at 0.25us / 1700Hz pulse, MP1)	1700Hz
(at 0.50us / 1200Hz pulse, MP2)	1202Hz
(at 0.80us / 750Hz pulse, LP1)	750.4Hz
(at 1.0us / 650Hz pulse, LP2)	651.8Hz

Spurious Emission at Antenna Terminal	Good
Field strength of spurious radiation	Good
Radiofrequency radiation exposure limits	Good

3.2.4 Receiver

MIC Front-end Ser. No.	B2950A
Diode limiter Ser. No.	A7274B
IF Center Frequency	60 MHz
IF Bandwidth	20/6/3 MHz

3.2.5 Dissipation Current (Power)

Input Voltage	12V	24V
(at 0.08us / 4000Hz pulse, SP1)	2.05A(24.6W)	1.06A(25.44W)
(at 0.08us / 2250Hz pulse, SP2)	1.77A(21.24W)	0.92A(22.08W)
(at 0.13us / 1700Hz pulse, SP3)	1.68A(20.16W)	0.88A(21.12W)
(at 0.25us / 1700Hz pulse, MP1)	1.85A(22.2W)	0.97A(23.28W)
(at 0.50us / 1200Hz pulse, MP2)	1.98A(23.76W)	1.02A(24.48W)
(at 0.80us / 750Hz pulse, LP1)	1.92A(23.04W)	1.00A(24.00W)
(at 1.0us / 650Hz pulse, LP2)	1.94A(23.28W)	1.00A(24.00W)

3.3 Overall Tests

Working Time of Timer	1min30sec
Input Variation (10.8Vdc – 31.2Vdc)	Good
Overall Sensitivity	Good
Minimum Range	Good
Bearing Accuracy	Good
Mechanical Noise	Good

4.1 RF Power Output

47 CFR sec. 2.1046

4.1.1 TEST SETUP

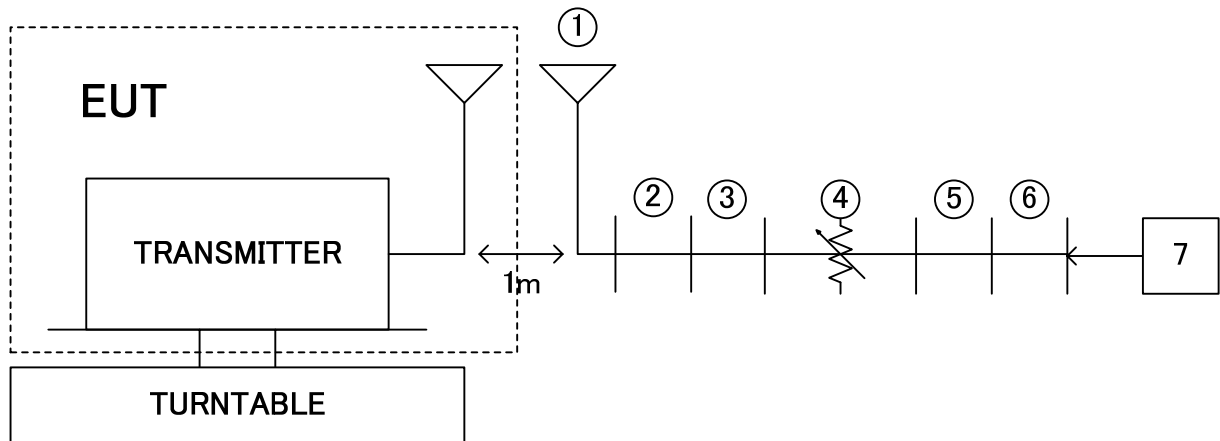

4.1.2 TEST INSTRUMENTS

	DESCRIPTION & MANUFACTURER	MODEL NO.	SERIAL NO.	CALIBRATION DATE	CALIBRATION DUE DATE
1	Double Ridge Horn Antenna ETS LINDGREN	3117	00091928	Sep. 28. 2011	Sep. 2012
2	Coaxial Cable HUBER+SUHNER	SUCOFLEX 100	NA	NA	NA
3	Adaptor MDL	90AC106-1E	NA	NA	NA
4	Variable Attenuator HP	X382A	13681	Jan. 21. 2011	Jan. 2012
5	Adaptor HP	X281A	NA	NA	NA
6	Coaxial Cable HUBER+SUHNER	SUCOFLEX 104PA	5994 /4PA	NA	NA
7	Spectrum Analyzer Agilent	E4448A	MY46180420	Oct. 31. 2011	Oct. 2012

4.1.3 TEST PROCEDURES

Reference to Section 2.2.17 Radiated Power Output on TIA-603-C.

4.1.4 EUT OPERATING CONDITIONS

- Placed the EUT on the testing table.
- Prepared other computer systems for controlling EUT and placed them outside of testing area.
- EUT can be transmitted seven pulses are 0.08us/4000Hz, 0.08us/2250Hz, 0.13us/1700Hz, 0.25us/1700Hz, 0.5us/1200Hz, 0.8us/750Hz, 1.0us/650Hz

4.1.5 TEST RESULTS

The radiated power output is calculated by the following:

$$\text{averageradiated power} = 10 \log \left(\frac{1}{8} \sum_{i=1}^{i=8} 10^{\frac{LVLi+LOSS}{10}} \right) \text{dBm}$$

PW [usec] / PRF [Hz]	0.08 / 4000			0.08 / 2250			0.13 / 1700		
Peak Power [dBm]	49.92			50.49			53.99		
Loss [dB]	-76.05			-76.05			-76.05		
i	RX level	+LOSS	in mW	RX level	+LOSS	in mW	RX level	+LOSS	in mW
1	-25.95	50.10	102329.30	-25.72	50.33	107894.67	-21.98	54.07	255270.13
2	-26.03	50.02	100461.58	-25.64	50.41	109900.58	-22.18	53.87	243781.08
3	-26.10	49.95	98855.31	-25.35	50.70	117489.76	-22.11	53.94	247742.21
4	-26.05	50.00	100000.00	-25.48	50.57	114024.98	-22.16	53.89	244906.32
5	-26.07	49.98	99540.54	-25.45	50.60	114815.36	-21.89	54.16	260615.35
6	-26.33	49.72	93756.20	-25.88	50.17	103992.02	-22.15	53.90	245470.89
7	-26.19	49.86	96827.79	-25.49	50.56	113762.73	-22.08	53.97	249459.47
8	-26.34	49.71	93540.57	-25.51	50.54	113240.04	-21.92	54.13	258821.29

0.25 / 1700			0.5 / 1200			0.8 / 750			1.0 / 650		
57.90			62.74			64.95			64.57		
-76.05			-76.05			-76.05			-76.05		
RX level	+LOSS	in mW	RX level	+LOSS	in mW	RX level	+LOSS	in mW	RX level	+LOSS	in mW
-18.22	57.83	606736.33	-13.32	62.73	1874994.51	-11.05	65.00	3162277.66	-11.42	64.63	2904022.65
-18.11	57.94	622300.29	-13.23	62.82	1914255.93	-11.19	64.86	3061963.43	-11.31	64.74	2978516.43
-18.12	57.93	620869.03	-13.19	62.86	1931968.32	-11.16	64.89	3083187.95	-11.87	64.18	2618183.01
-18.11	57.94	622300.29	-13.44	62.61	1823895.70	-11.04	65.01	3169567.46	-11.57	64.48	2805433.64
-18.14	57.91	618016.40	-13.39	62.66	1845015.42	-10.81	65.24	3341950.40	-11.44	64.61	2890679.88
-18.23	57.82	605340.87	-13.22	62.83	1918668.74	-11.35	64.70	2951209.23	-11.50	64.55	2851018.27
-18.08	57.97	626613.86	-13.38	62.67	1849268.62	-11.12	64.93	3111716.34	-11.31	64.74	2978516.43
-18.23	57.82	605340.87	-13.32	62.73	1874994.51	-11.12	64.93	3111716.34	-11.41	64.64	2910717.12

4.1.6 TEST CONDITIONS

Tamb = 20°C to 25°C, RHamb = 40% ~ 60%

EUT input = 24 VDC

4.1.7 STABILIZATION

EUT energized for 10 minutes minimum.

4.1.8 TEST EQUIPMENT

JRC Original – Shielded Room

Other equipment – see test set-ups.

4.1.9 DATE

26th Dec., 2011

TESTED BY G. Higuchi

4.2 Spurious emission at antenna terminals

47 CFR sec. 2.1051

4.2.1.1 TEST SETUP for range 10kHz to 12.5GHz

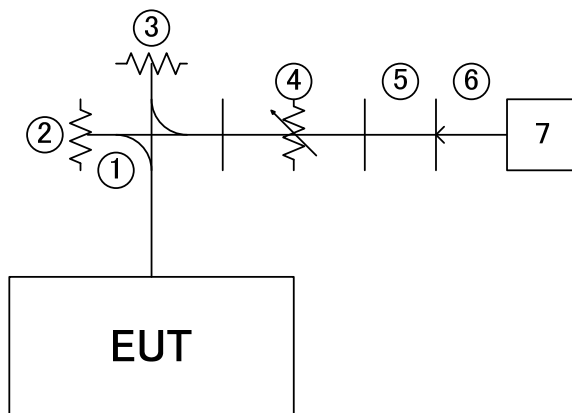

4.2.1.2 TEST INSTRUMENT

	DESCRIPTION & MANUFACTURER	MODEL NO.	SERIAL NO.	CALIBRATION DATE	CALIBRATION DUE DATE
1	Direction Coupler (30dB) SHIMADARIKA	5D363	R11421	NA	NA
2	Dummy Load PASTERNAK	PE6815	NA	NA	NA
3	High Power Dummy Load PASTERNAK	PE6824	NA	NA	NA
4	Variable Attenuator HP	X382A	13681	Jan. 21. 2011	Jan. 2012
5	Adaptor MDL	90AC106-1E	NA	NA	NA
6	Coaxial Cable HUBER+SUHNER	SUCOFLEX 100	NA	NA	NA
7	Spectrum Analyzer Agilent	E4448A	MY46180420	Oct. 31. 2011	Oct. 2012

Measurement Point : Antenna terminal

Spectrum Analyzer setting: RBW = 10kHz less than 1GHz, 1MHz above 1GHz

VBW = 300kHz less than 1GHz, 3MHz above 1GHz

Detector Mode = Positive Peak

4.2.1.3 TEST PROCEDURES

- a. Setup EUT as 4.2.1.
- b. Transmitted at most powerful pulse and adjusted attenuator for not exceeding the spectrum analyzer maximum rating.
- c. Transmitted at seven pulses are 0.08us/4000Hz, 0.08us/2250Hz, 0.13us/1700Hz, 0.25us/1700Hz, 0.5us/1200Hz, 0.8us/750Hz, 1.0us/650Hz, and capture the spectrum at 10kHz to 12.5GHz.

4.2.1.4 EUT OPERATING CONDITIONS

- a. Placed the EUT on the testing table.
- b. Prepared other computer systems for controlling EUT and placed them outside of testing area.

4.2.1.5 TEST RESULTS

No spurious emissions observed above minimum standard.

Test data is described at section 4.2.1.10 to 4.2.1.16

4.2.1.6 TEST CONDITIONS

Tamb = 20°C to 25°C, RHamb = 40% ~ 60%

EUT input = 24 VDC

4.2.1.7 STABILIZATION

EUT energized for 10 minutes minimum.

4.2.1.8 TEST EQUIPMENT

JRC Original – Shielded Room

Other equipment – see test set-ups.

4.2.1.9 DATE

19th Dec., 2011

TESTED BY G. Higuchi

4.2.1.10 TEST RESULTS of 0.08usec/4000Hz pulse

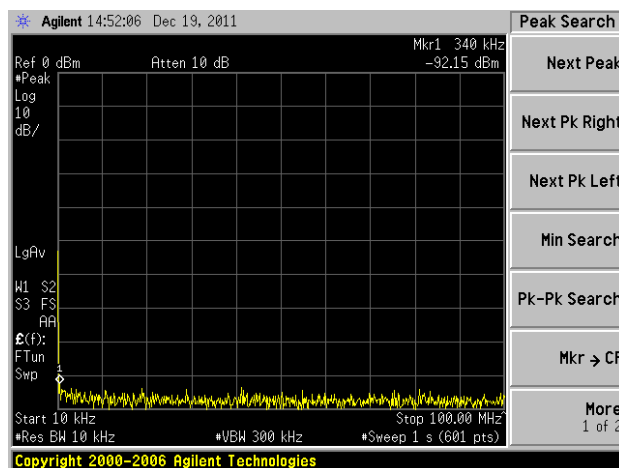

10kHz to 100MHz

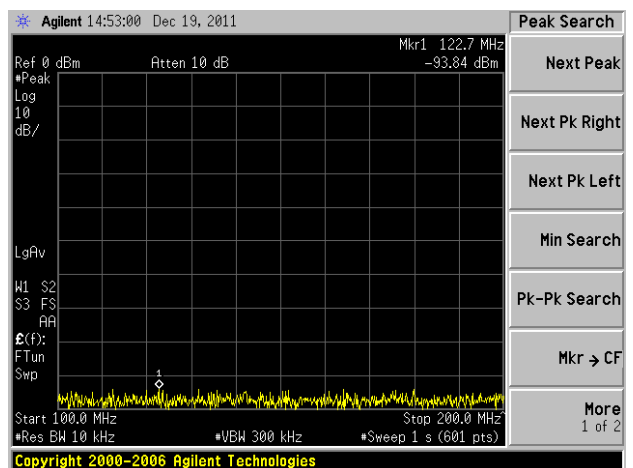

100MHz to 200MHz

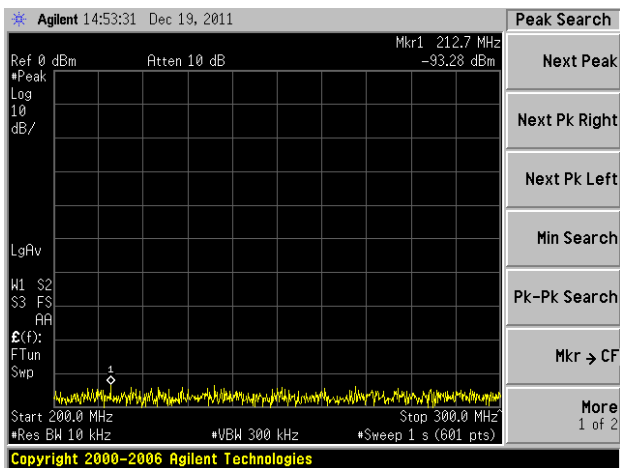

200MHz to 300MHz

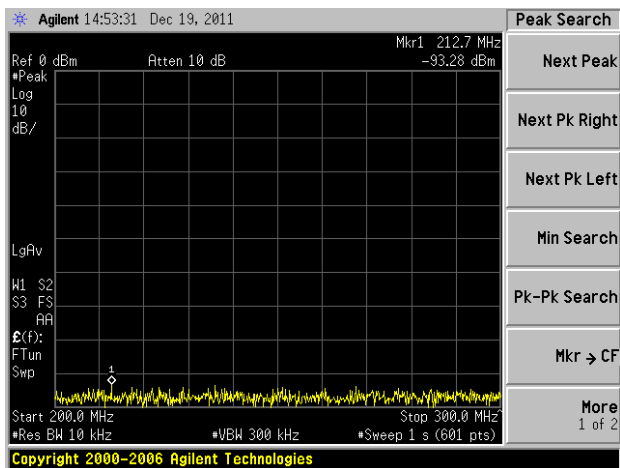

300MHz to 400MHz

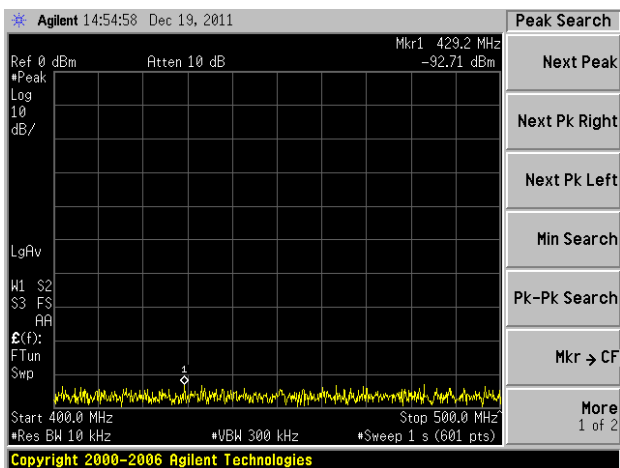

400MHz to 500MHz

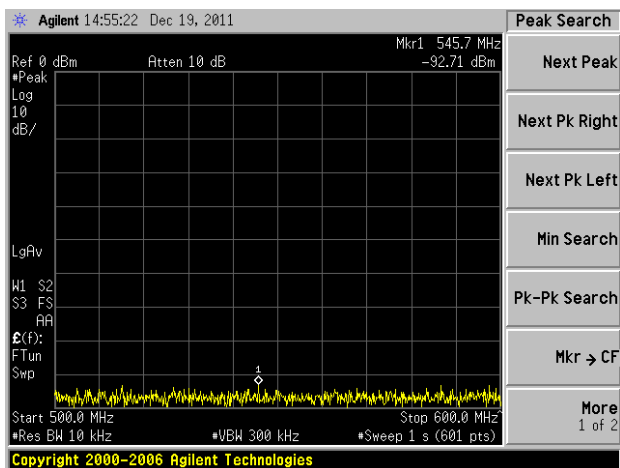

500MHz to 600MHz

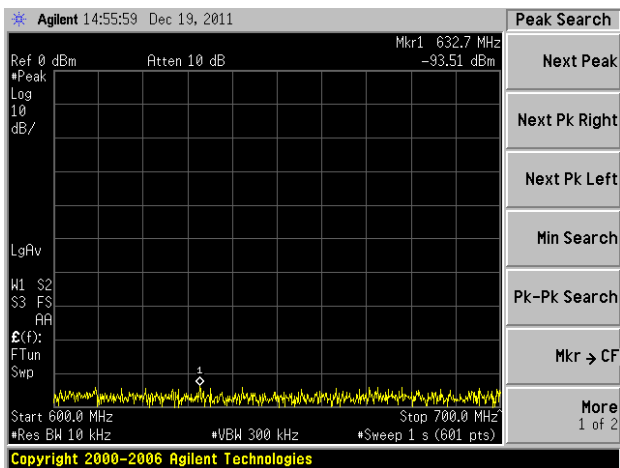

600MHz to 700MHz

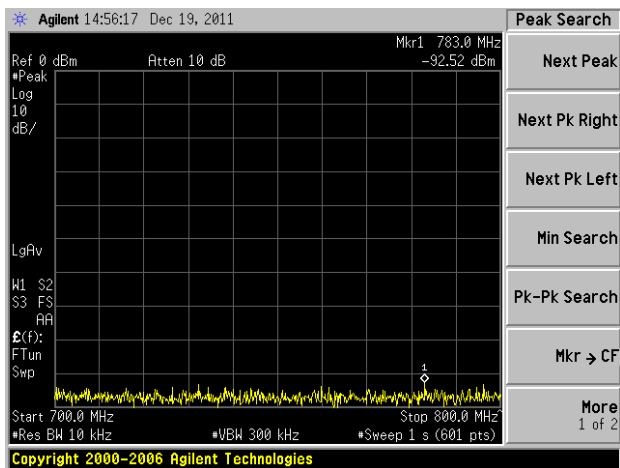

700MHz to 800MHz

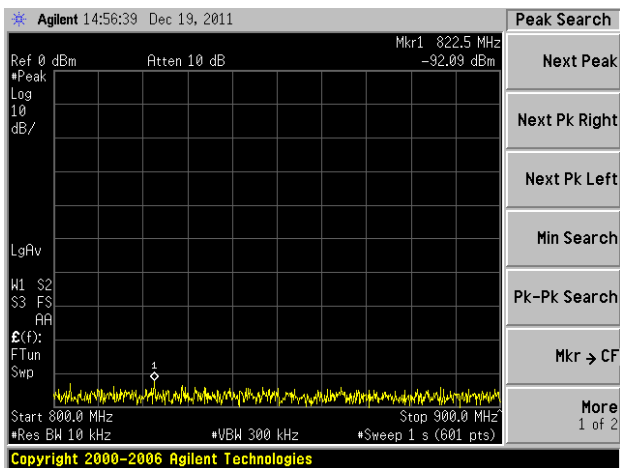

800MHz to 900MHz

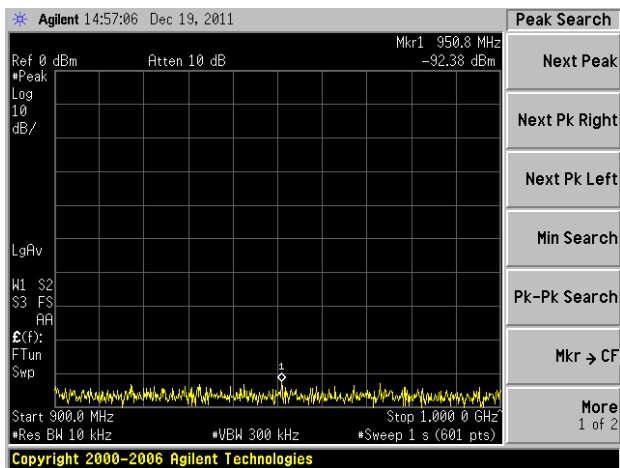

900MHz to 1GHz

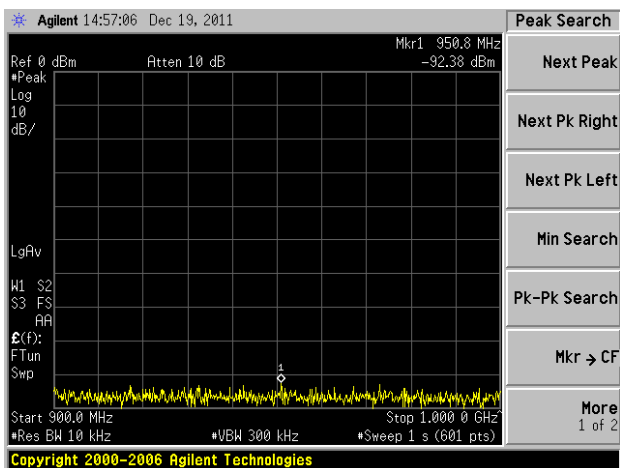

1.0GHz to 2.9GHz

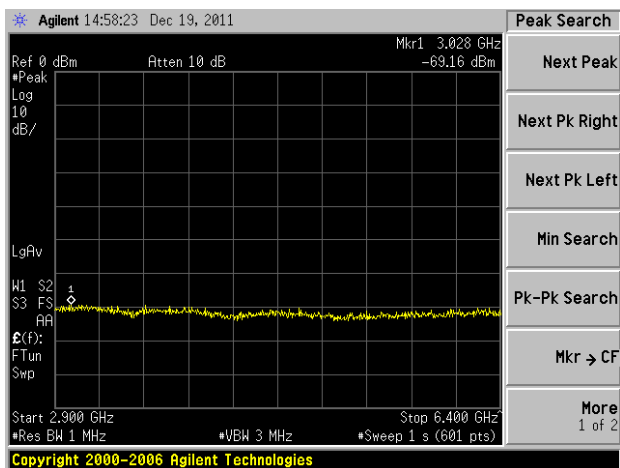

2.9GHz to 6.4GHz

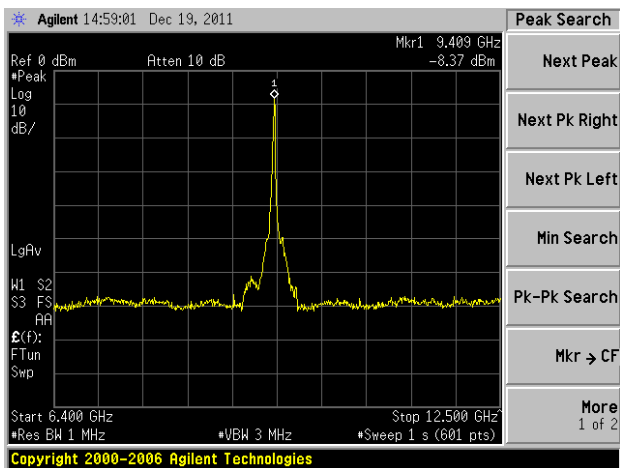

6.4GHz to 12.5GHz

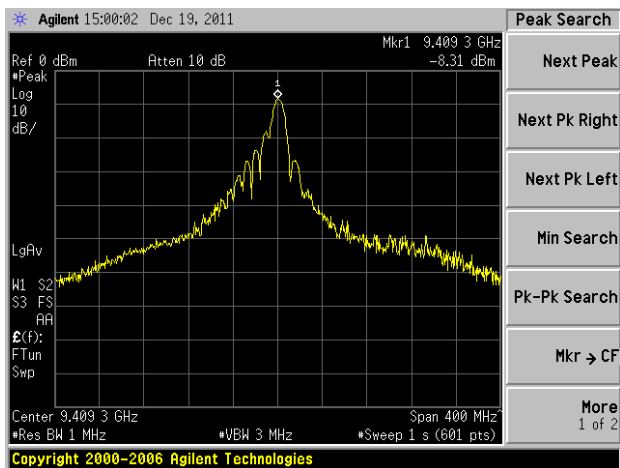

Center 9409.3MHz, Span 400MHz

4.2.1.11 TEST RESULTS of 0.08usec/2250Hz pulse

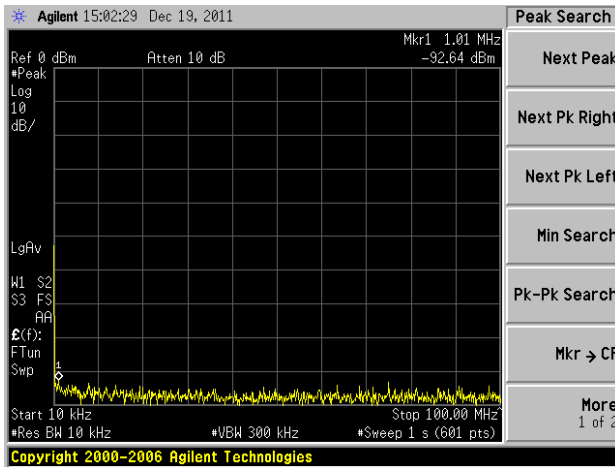

10kHz to 100MHz

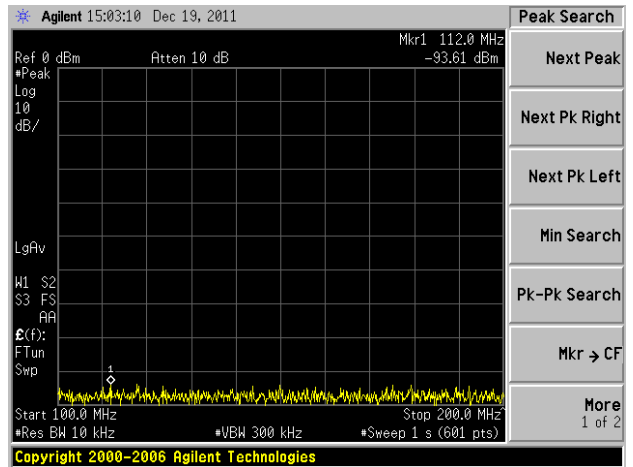

100MHz to 200MHz

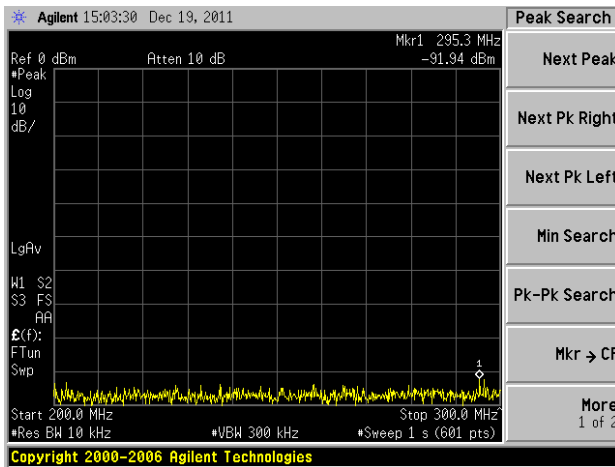

200MHz to 300MHz

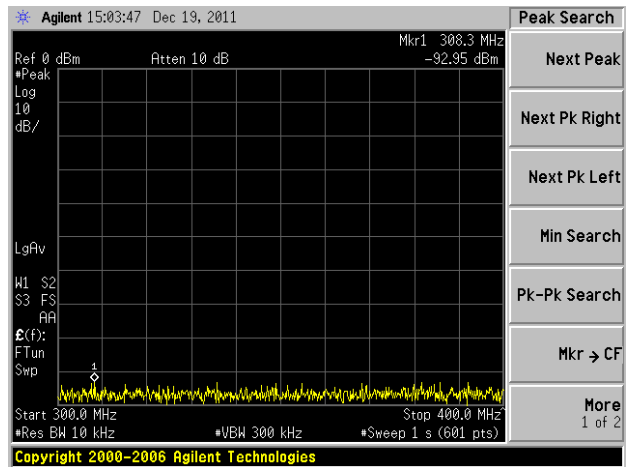

300MHz to 400MHz

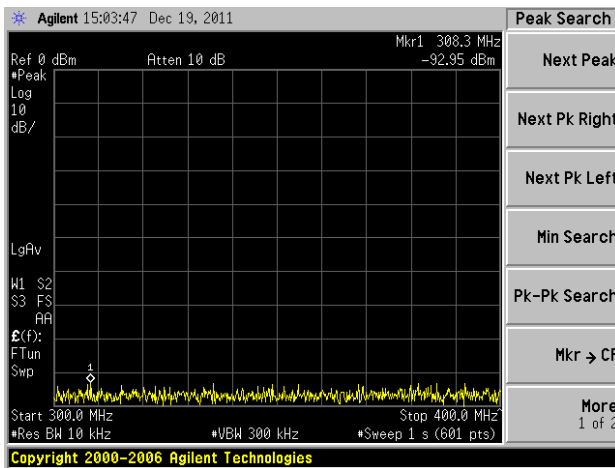

400MHz to 500MHz

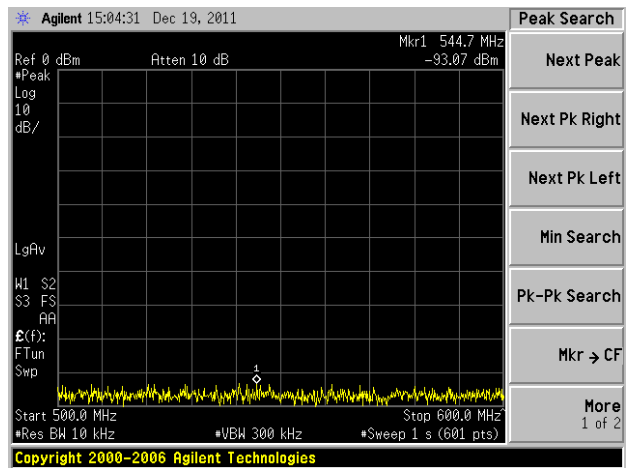

500MHz to 600MHz

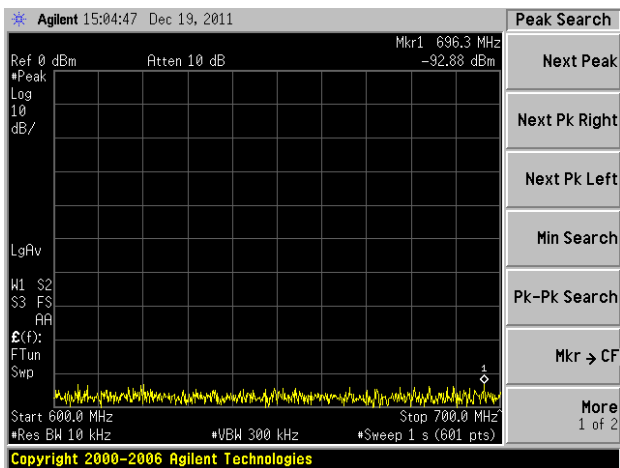

600MHz to 700MHz

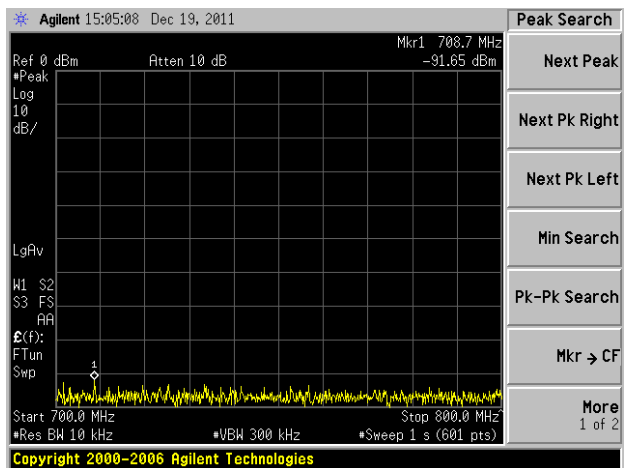

700MHz to 800MHz

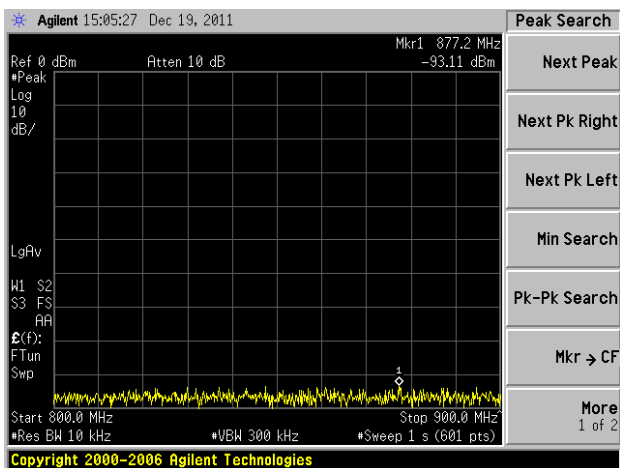

800MHz to 900MHz

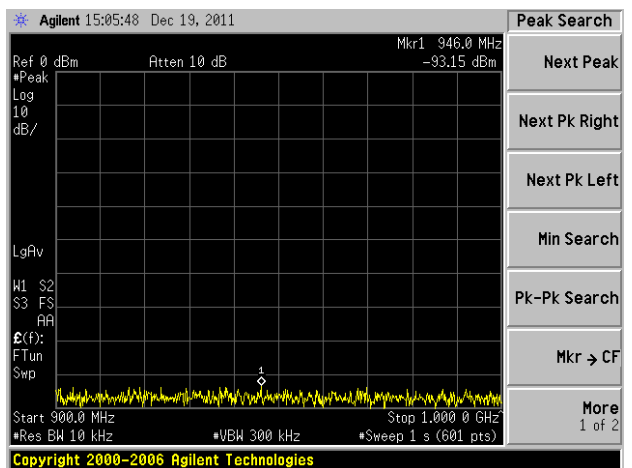

900MHz to 1.0GHz

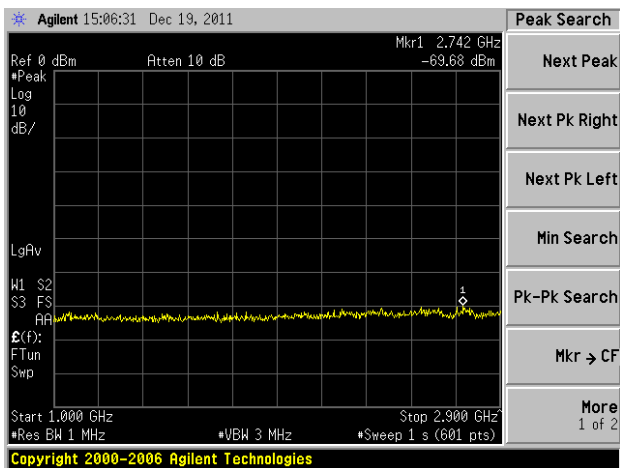

1.0GHz to 2.9GHz

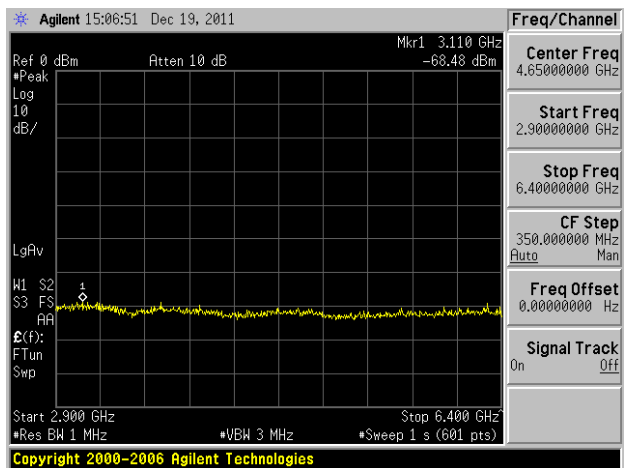

2.9GHz to 6.4GHz

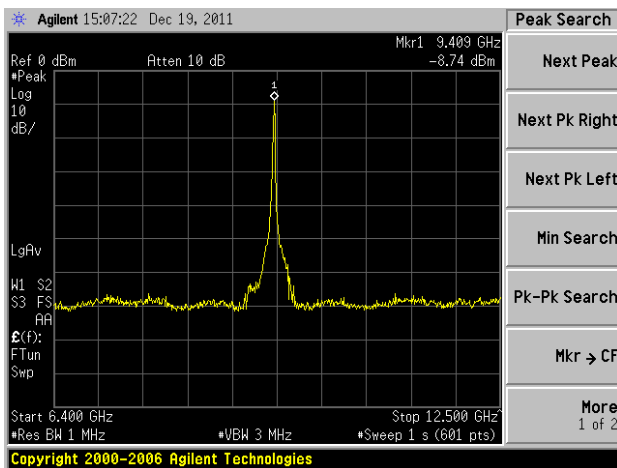

6.4GHz to 12.5GHz

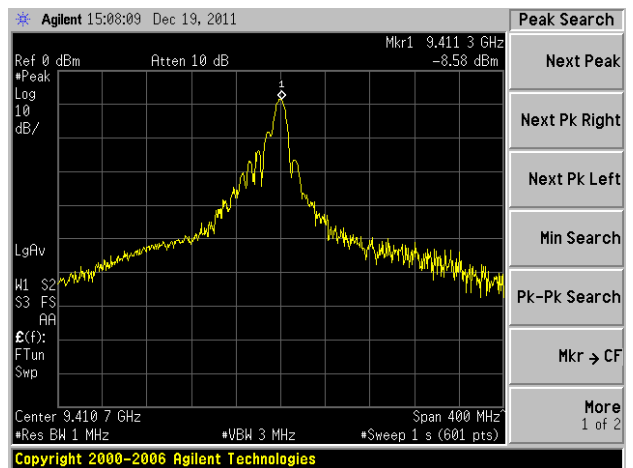

Center 9411.3MHz, Span 400MHz

4.2.1.12 TEST RESULTS of 0.13usec/1700Hz pulse

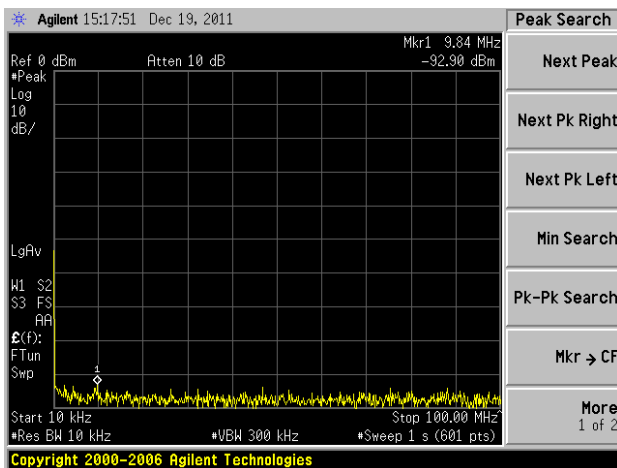

10kHz to 100MHz

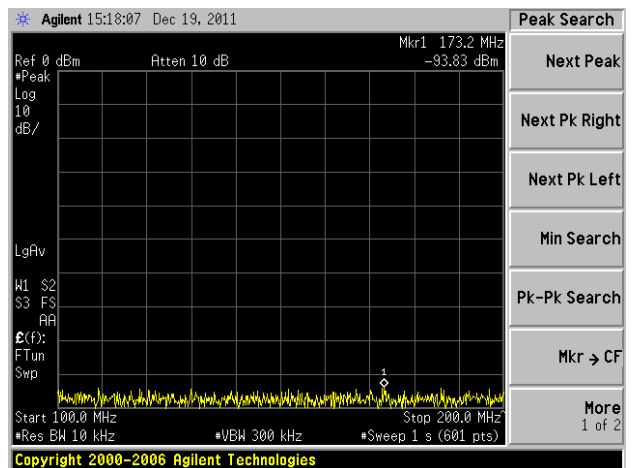

100MHz to 200MHz

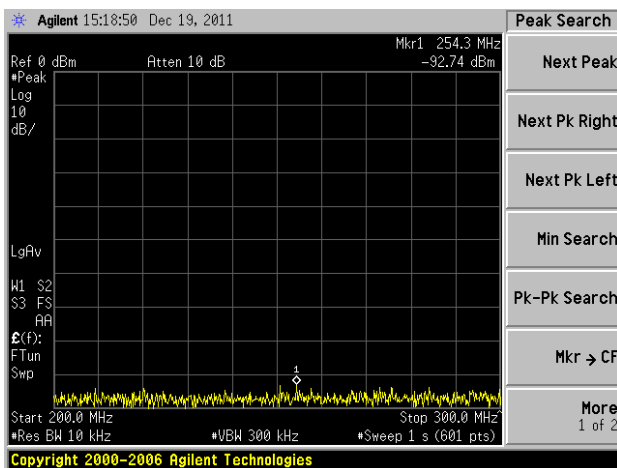

200MHz to 300MHz

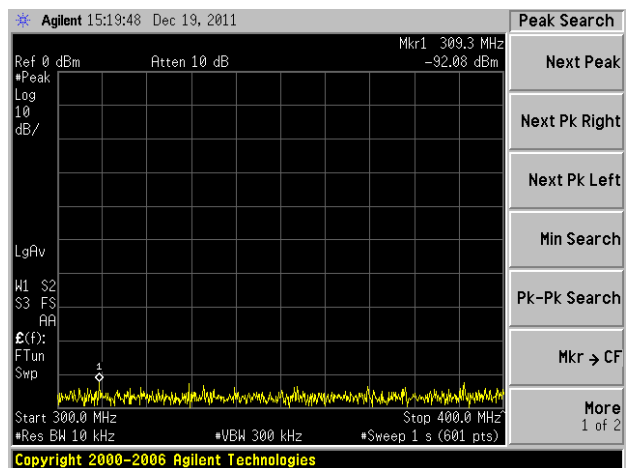

300MHz to 400MHz

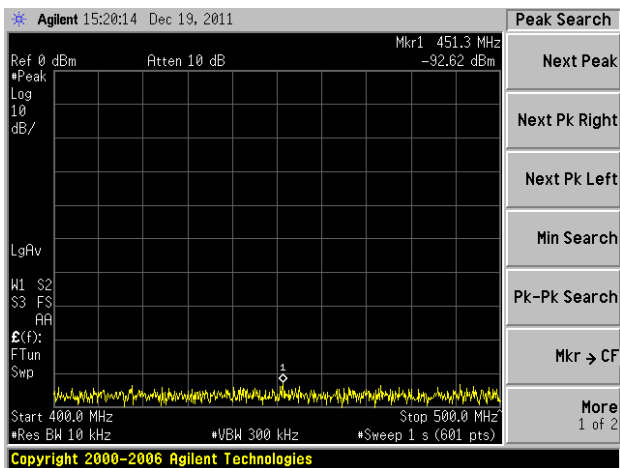

400MHz to 500MHz

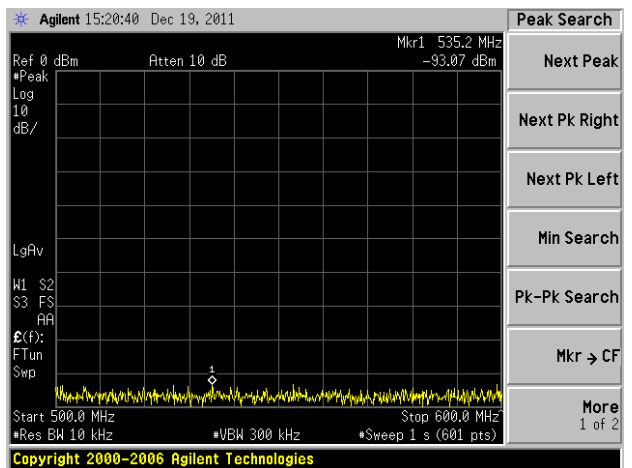

500MHz to 600MHz

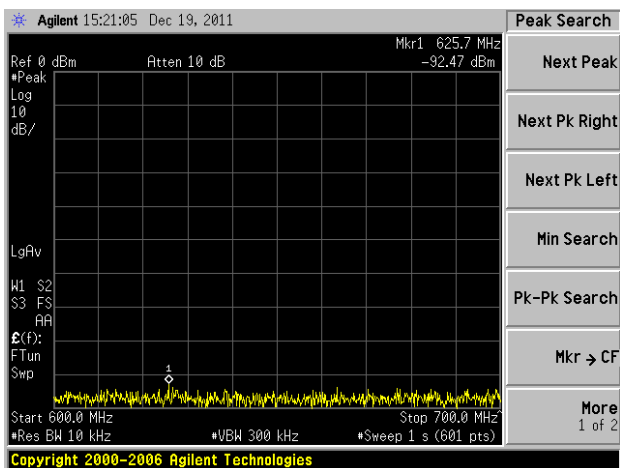

600MHz to 700MHz

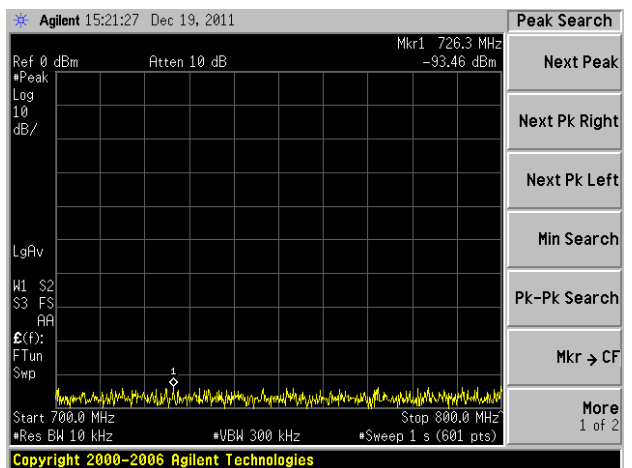

700MHz to 800MHz

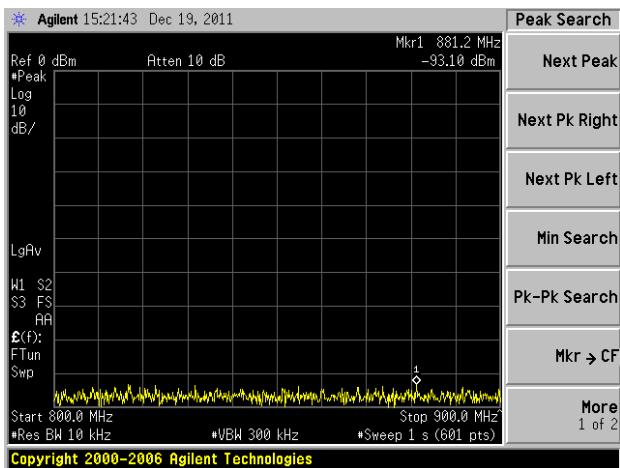

800MHz to 900MHz

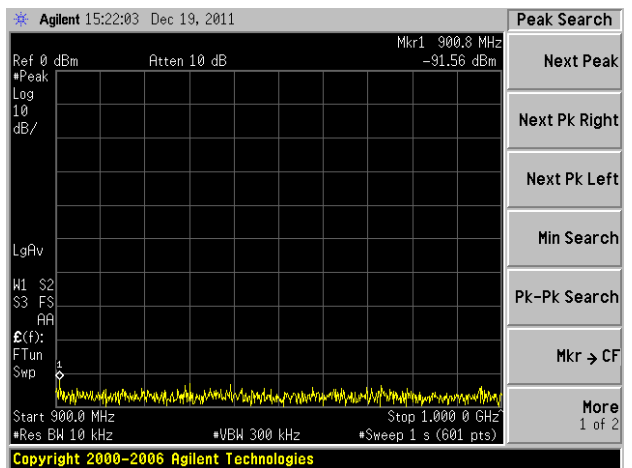

900MHz to 1GHz

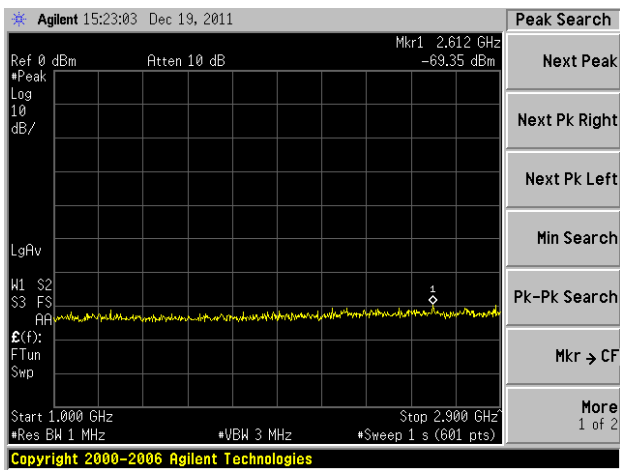

1.0GHz to 2.9GHz

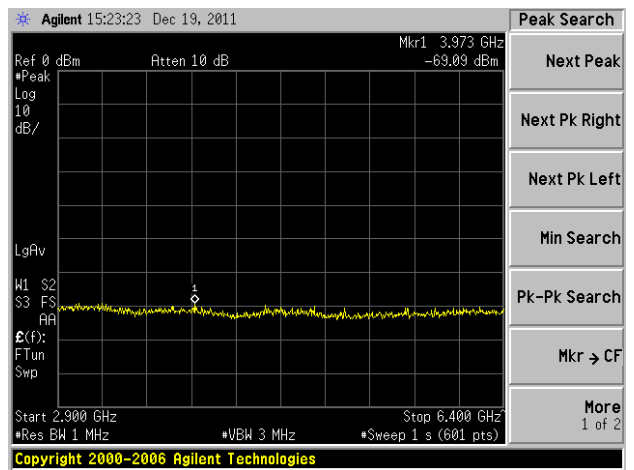

2.9GHz to 6.4GHz

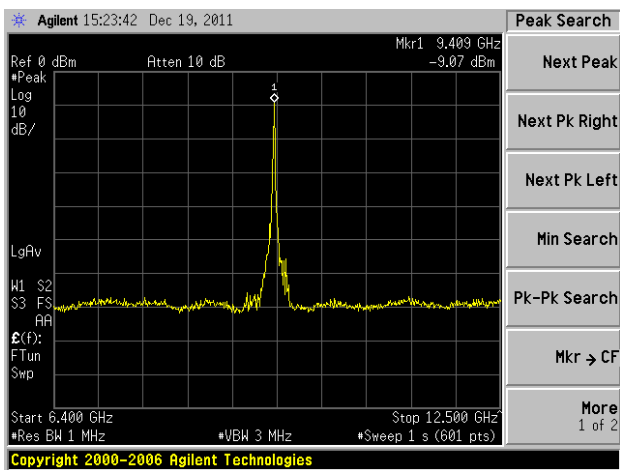

6.4GHz to 12.5GHz

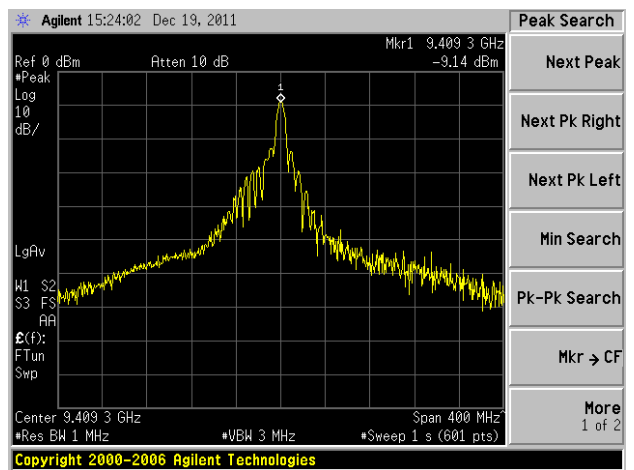

Center 9409.3MHz, Span 400MHz

4.2.1.13 TEST RESULTS of 0.25usec/1700Hz pulse

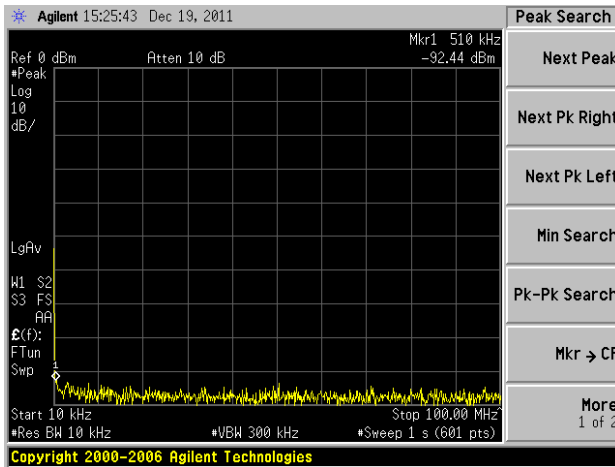

10kHz to 100MHz

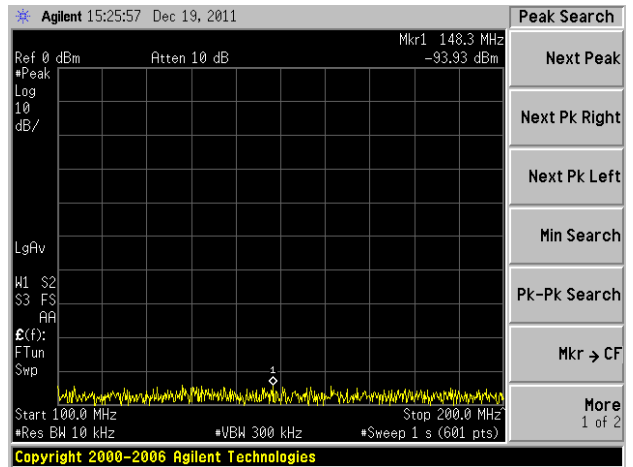

100MHz to 200MHz

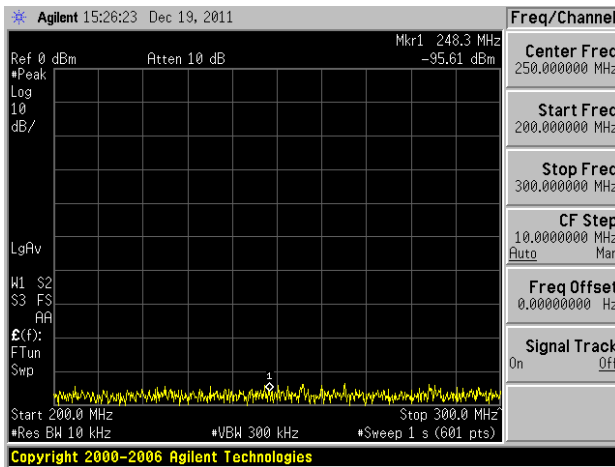

200MHz to 300MHz

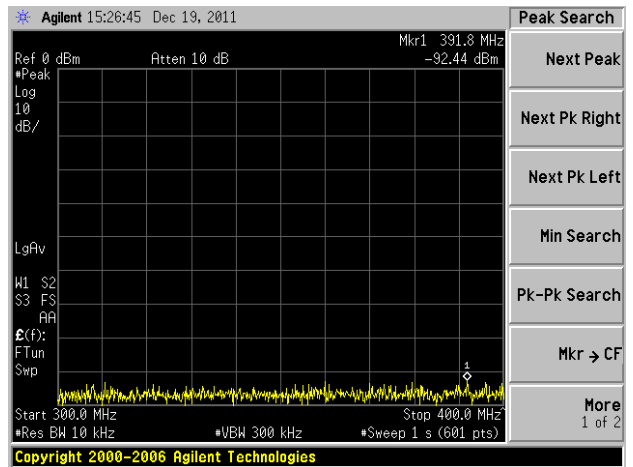

300MHz to 400MHz

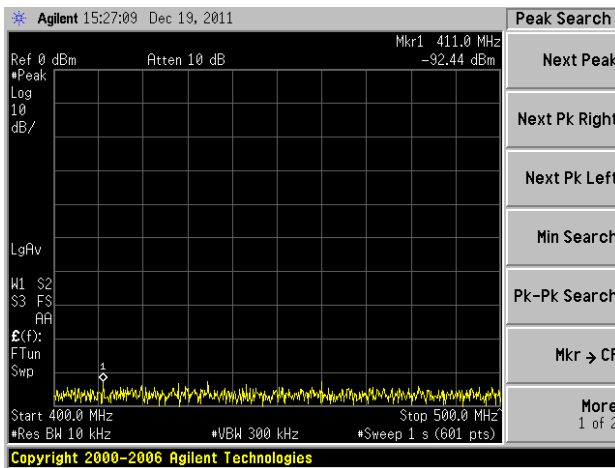

400MHz to 500MHz

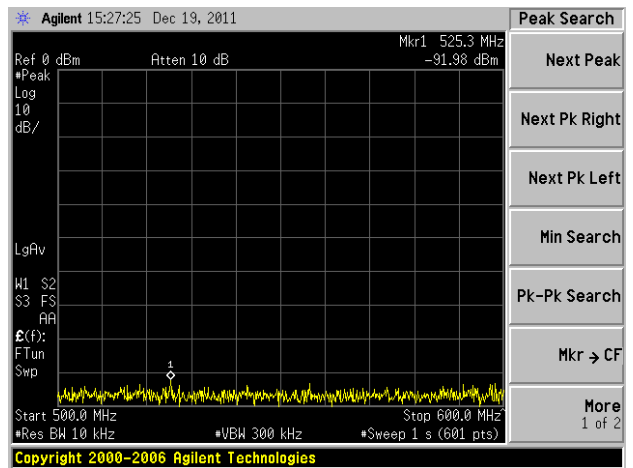

500MHz to 600MHz

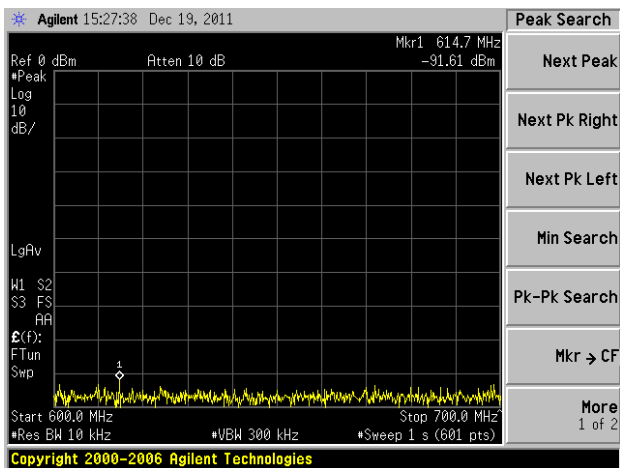

600MHz to 700MHz

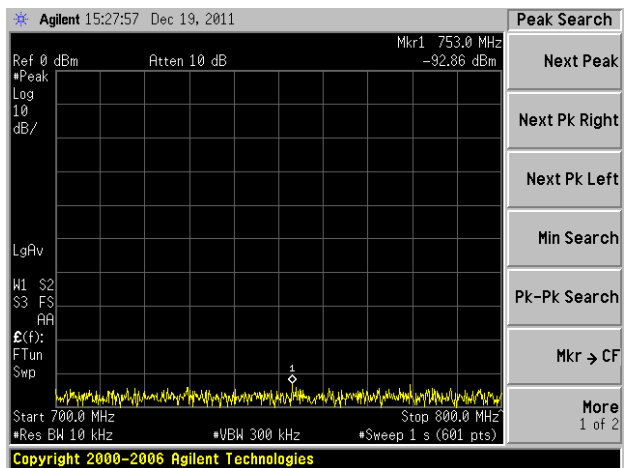

700MHz to 800MHz

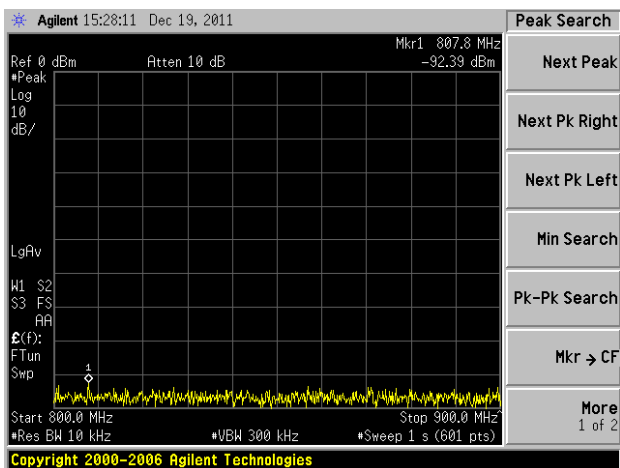

800MHz to 900MHz

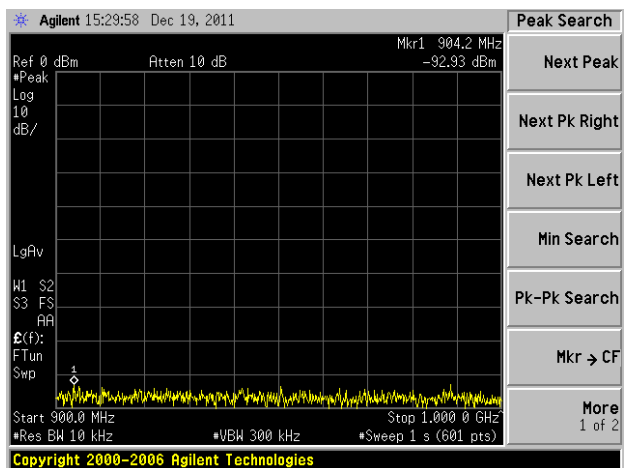

900MHz to 1GHz

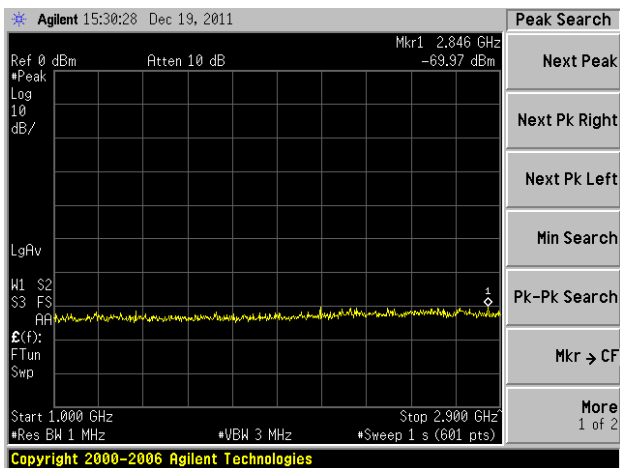

1.0GHz to 2.9GHz

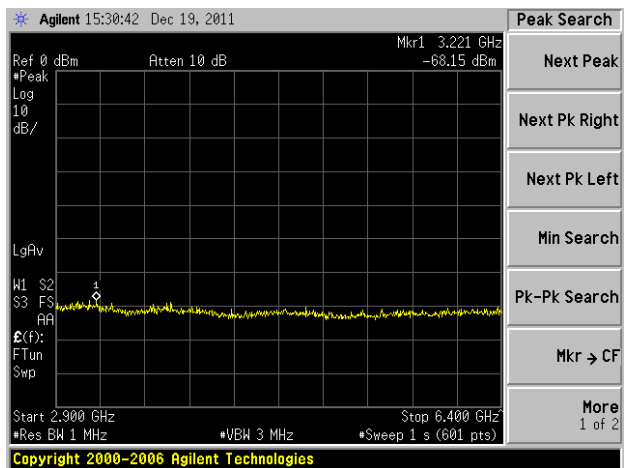

2.9GHz to 6.4GHz

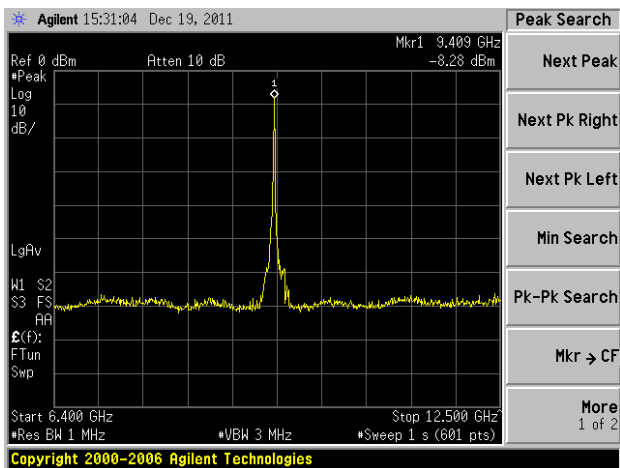

6.4GHz to 12.5GHz

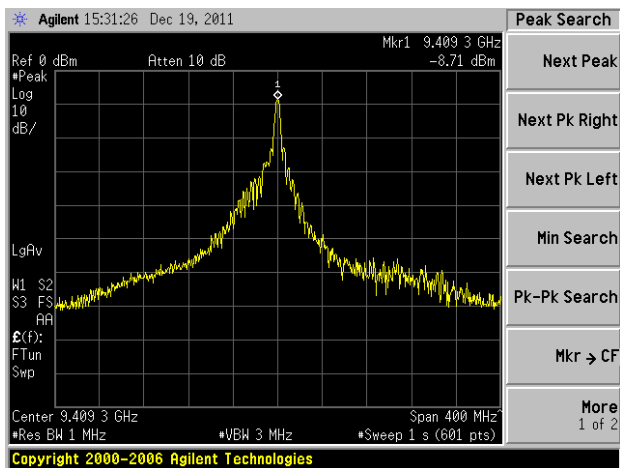

Center 9409.3MHz, Span 400MHz

4.2.1.14 TEST RESULTS of 0.5usec/1200Hz pulse

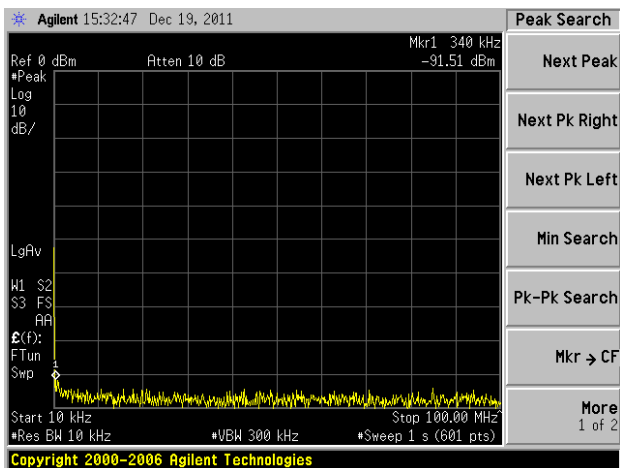

10kHz to 100MHz

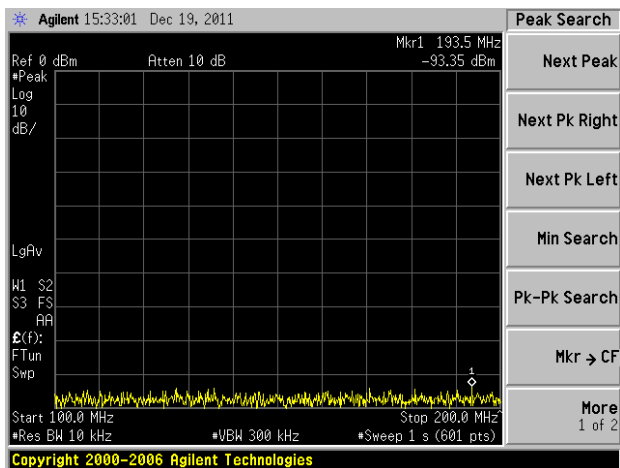

100MHz to 200MHz

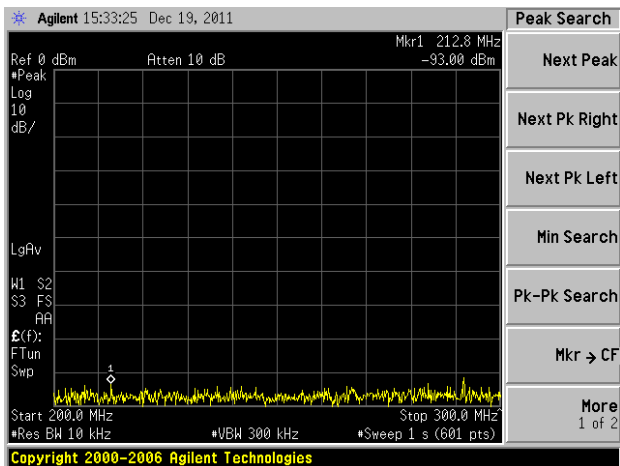

200MHz to 300MHz

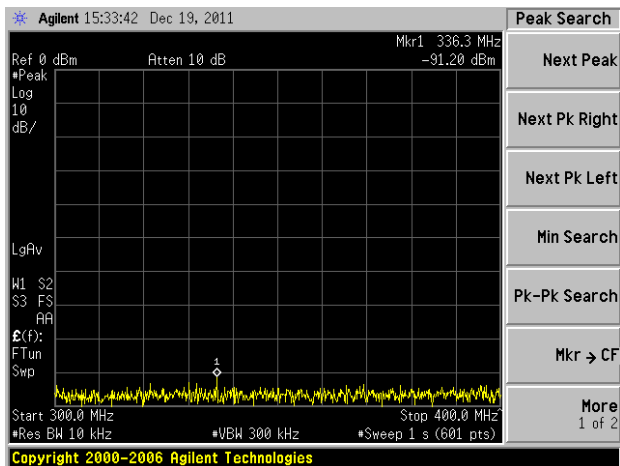

300MHz to 400MHz

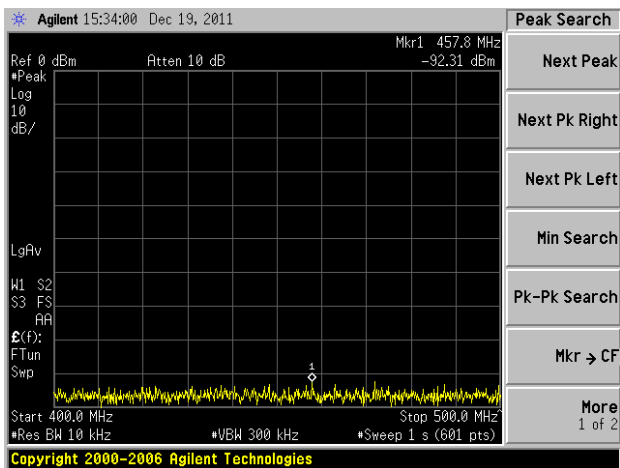

400MHz to 500MHz

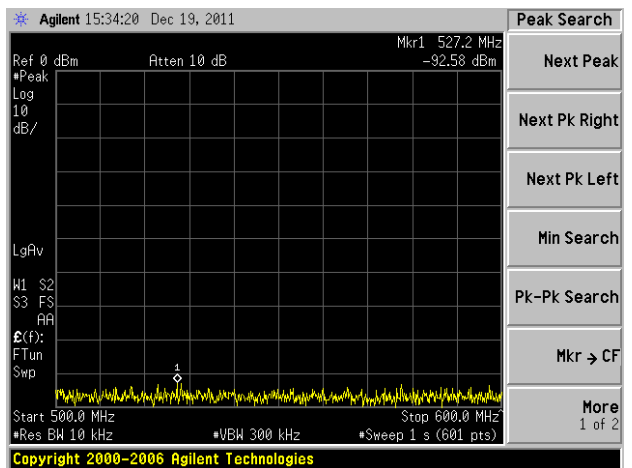

500MHz to 600MHz

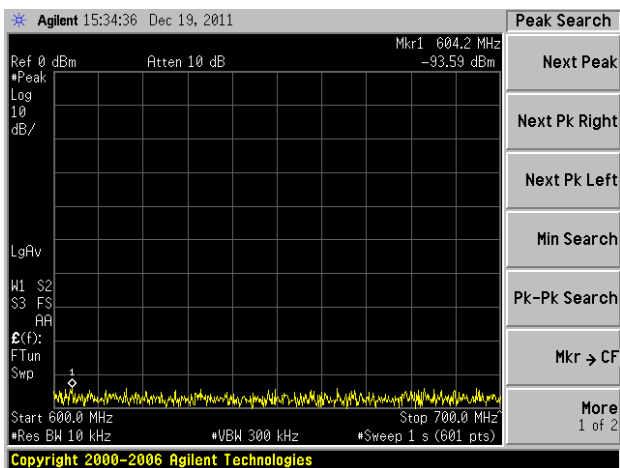

600MHz to 700MHz

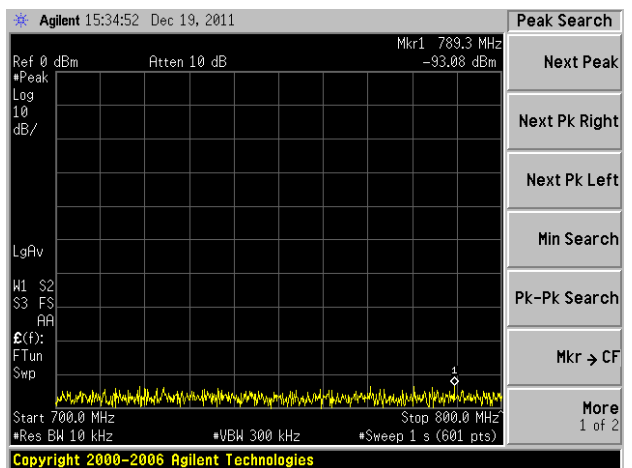

700MHz to 800MHz

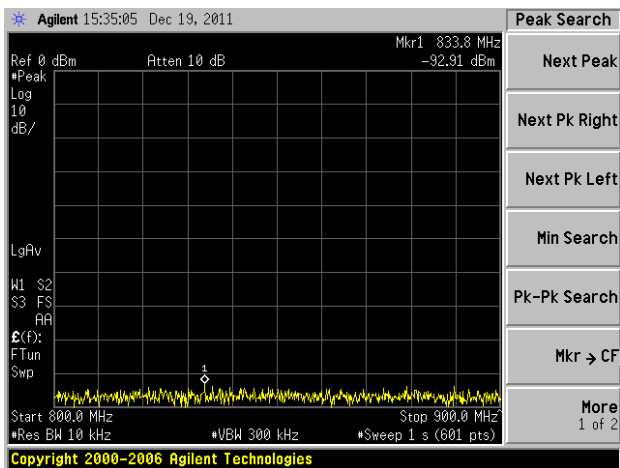

800MHz to 900MHz

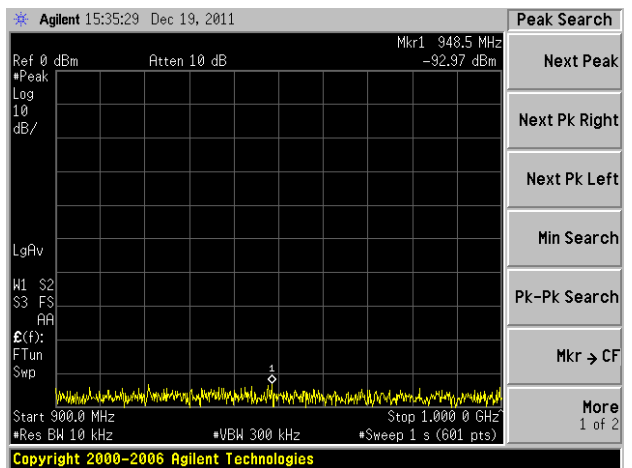

900MHz to 1GHz

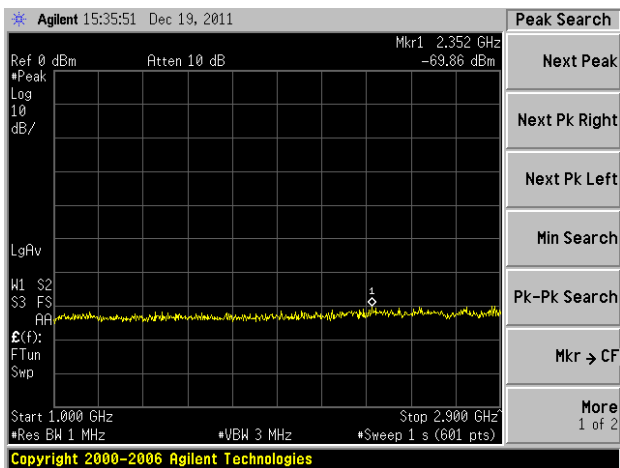

1.0GHz to 2.9GHz

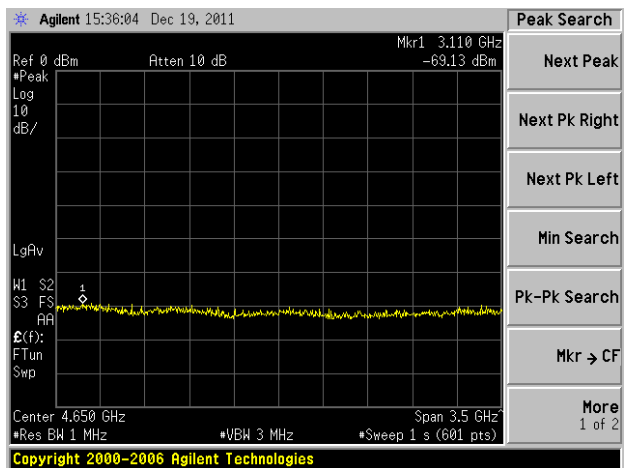

2.9GHz to 6.4GHz

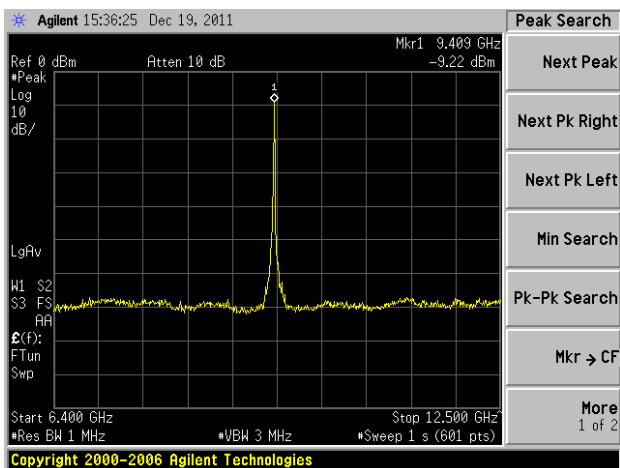

6.4GHz to 12.5GHz

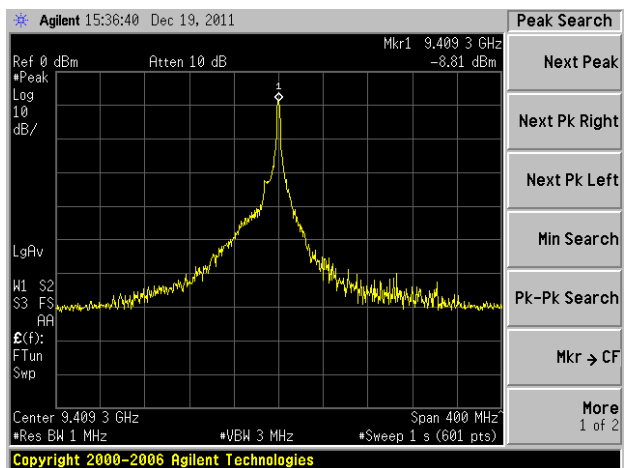

Center 9409.3MHz, Span 400MHz

4.2.1.15 TEST RESULTS of 0.8usec/750Hz pulse

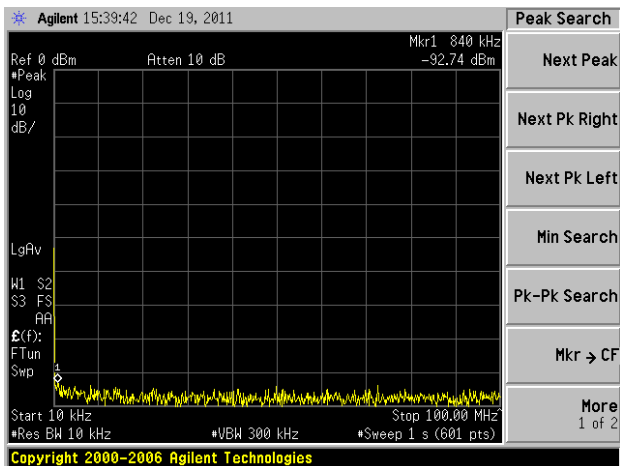

10kHz to 100MHz

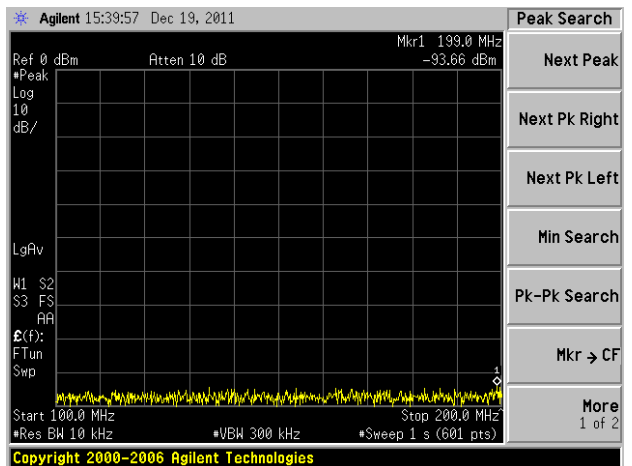

100MHz to 200MHz

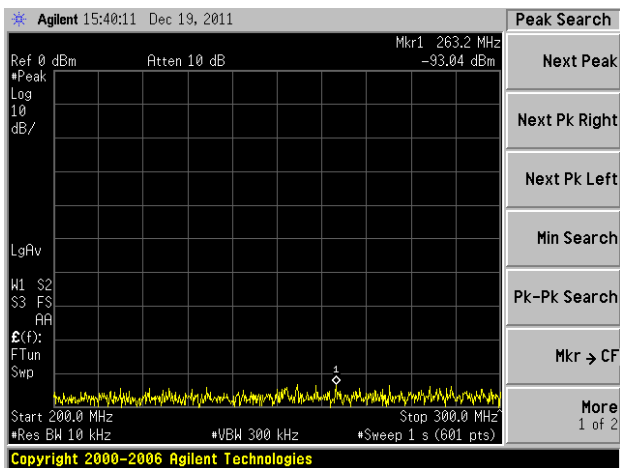

200MHz to 300MHz

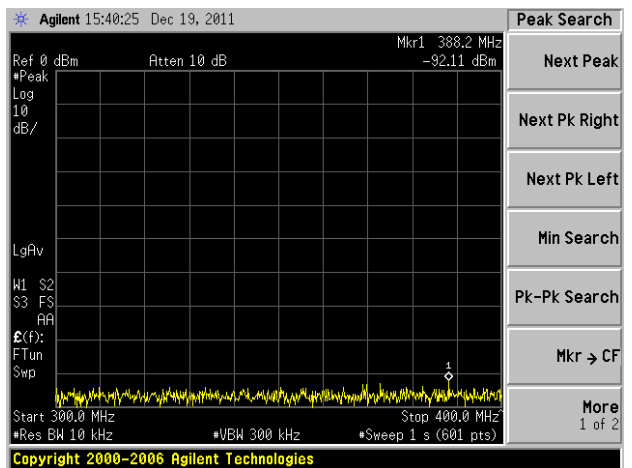

300MHz to 400MHz

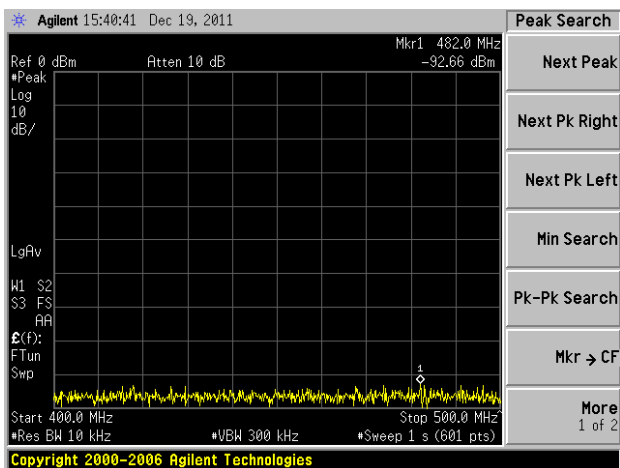

400MHz to 500MHz

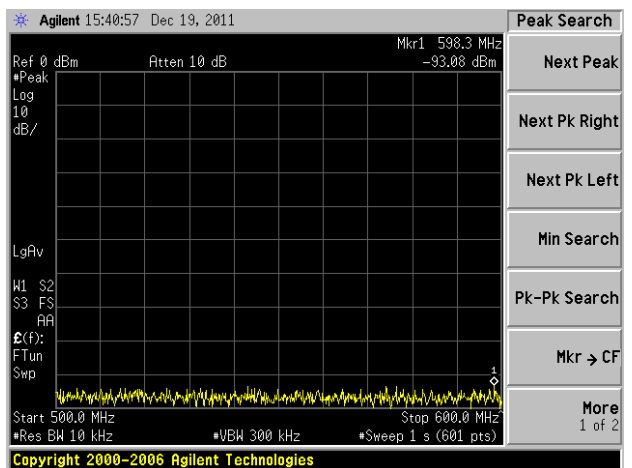

500MHz to 600MHz

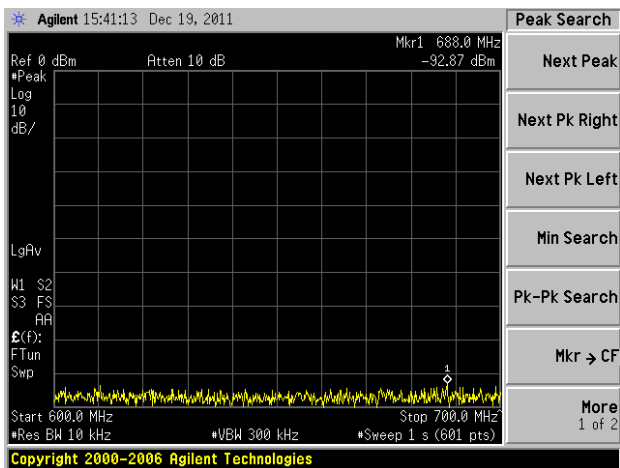

600MHz to 700MHz

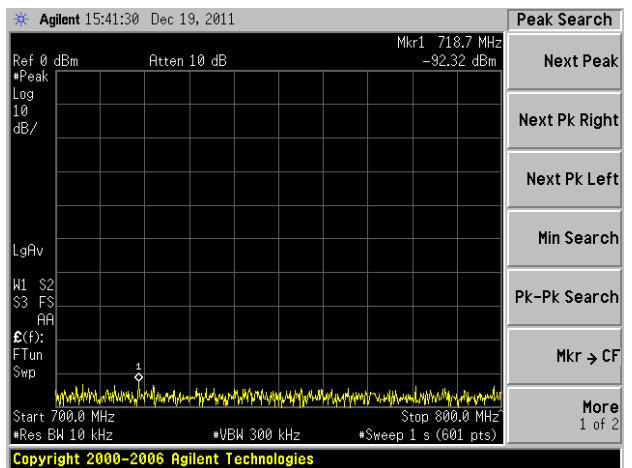

700MHz to 800MHz

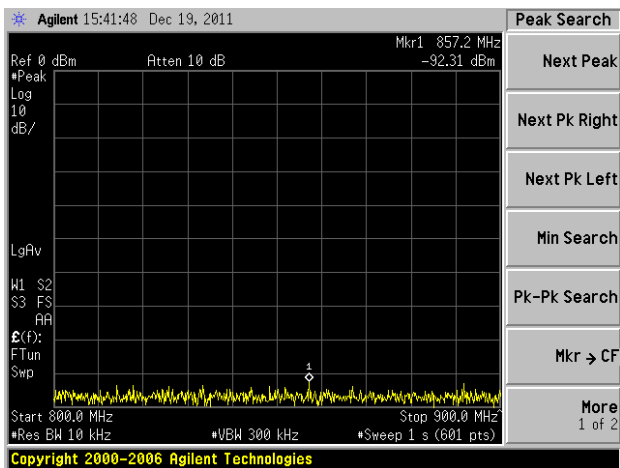

800MHz to 900MHz

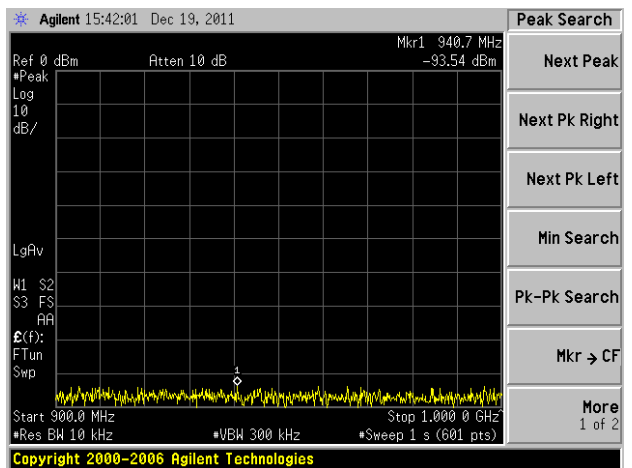

900MHz to 1GHz

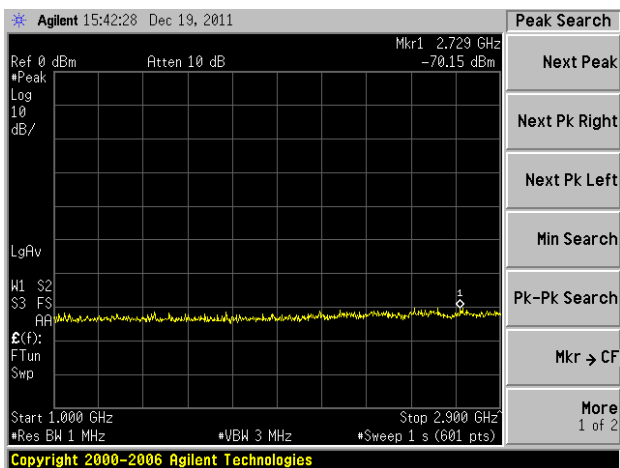

1.0GHz to 2.9GHz

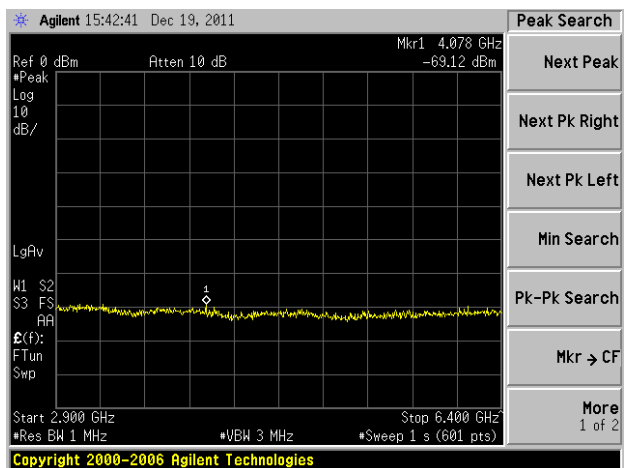

2.9GHz to 6.4GHz

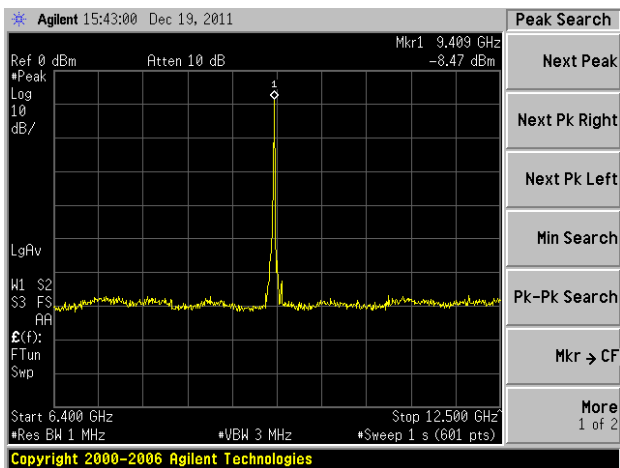

6.4GHz to 12.5GHz

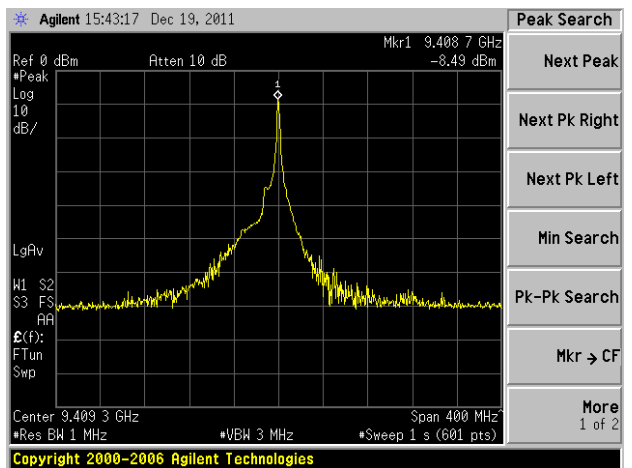

Center 9408.7MHz, Span 400MHz

4.2.1.16 TEST RESULTS of 1.0usec/650Hz pulse

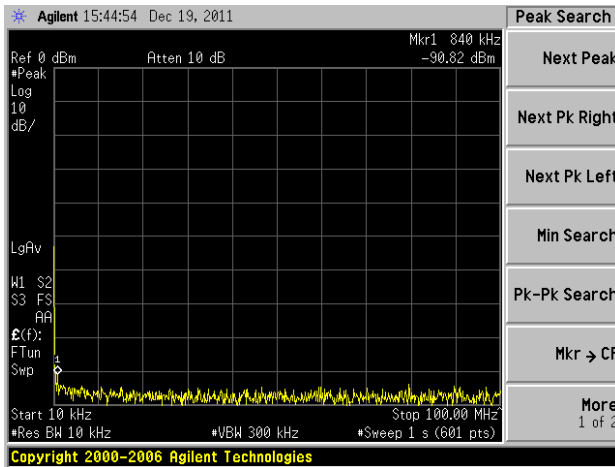

10kHz to 100MHz

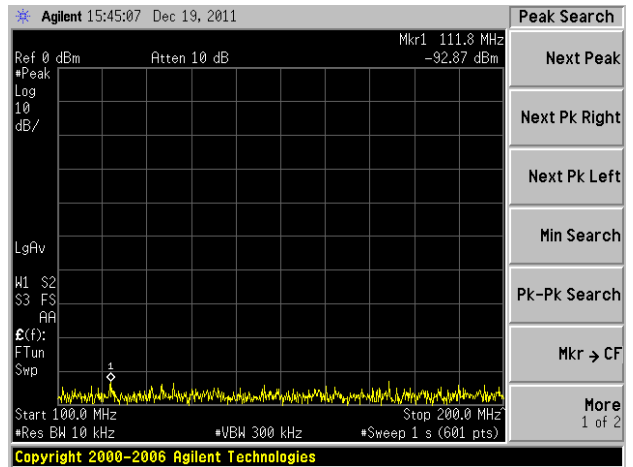

100MHz to 200MHz

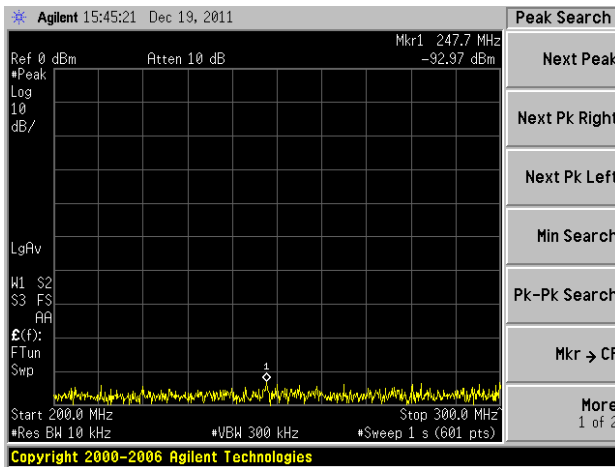

200MHz to 300MHz

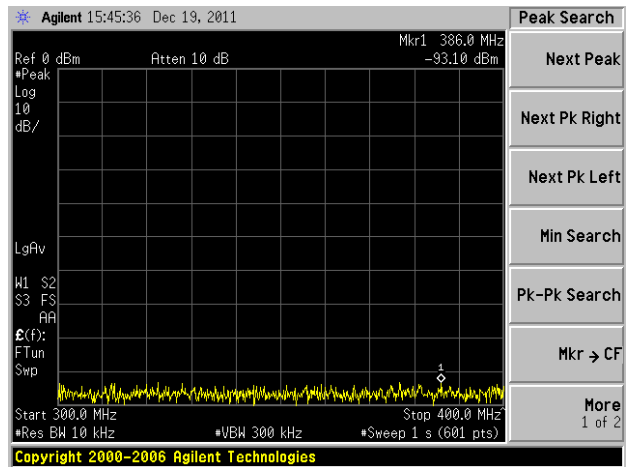

300MHz to 400MHz

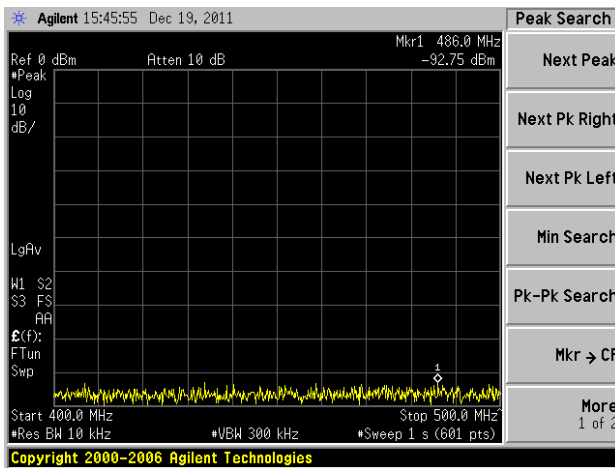

400MHz to 500MHz

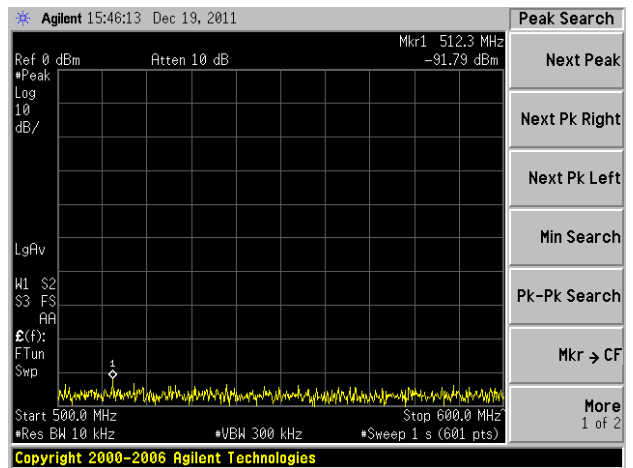

500MHz to 600MHz

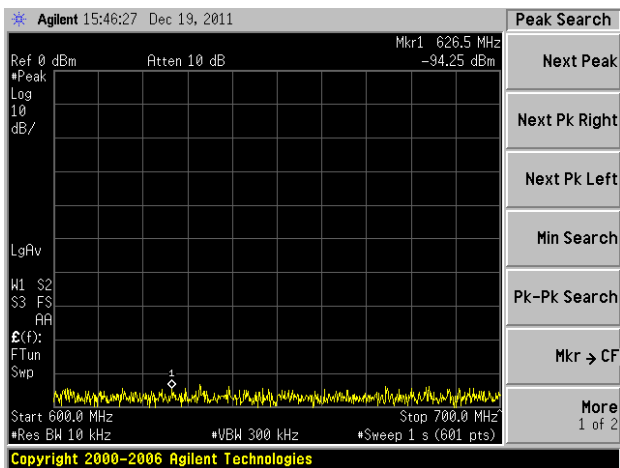

600MHz to 700MHz

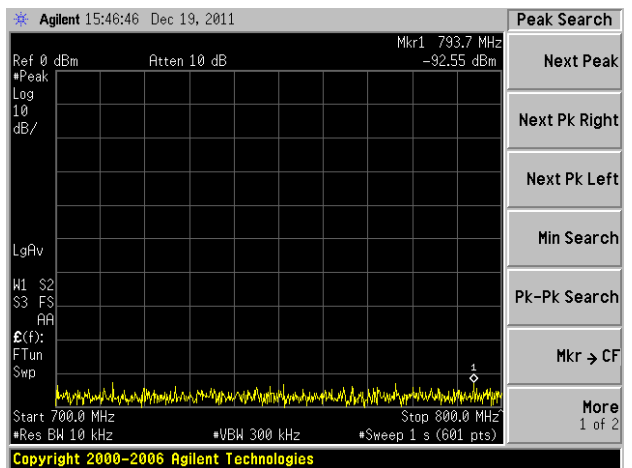

700MHz to 800MHz

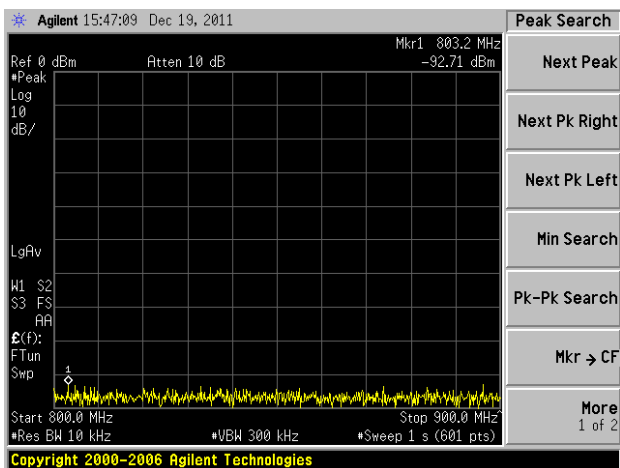

800MHz to 900MHz

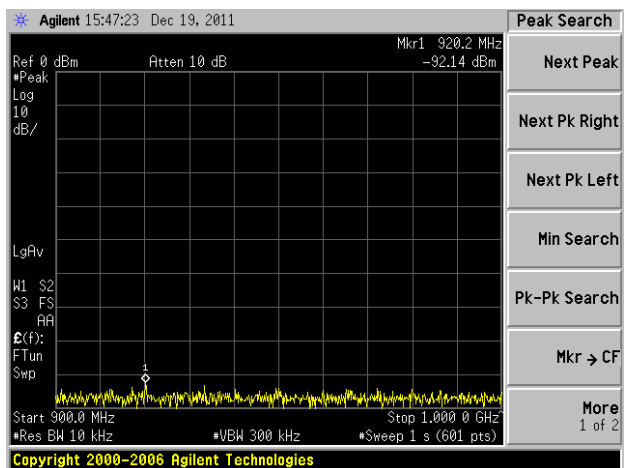

900MHz to 1GHz

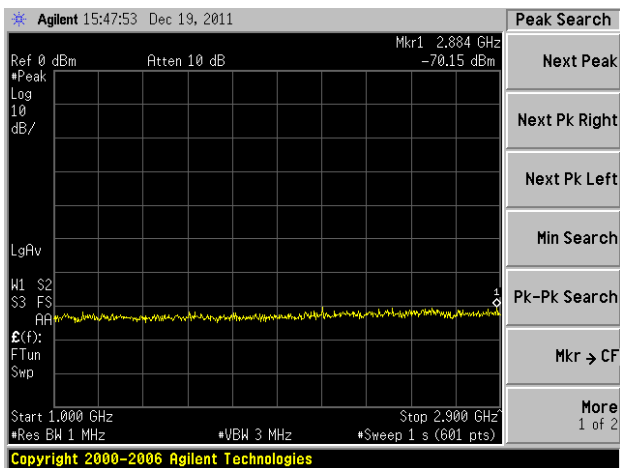

1.0GHz to 2.9GHz

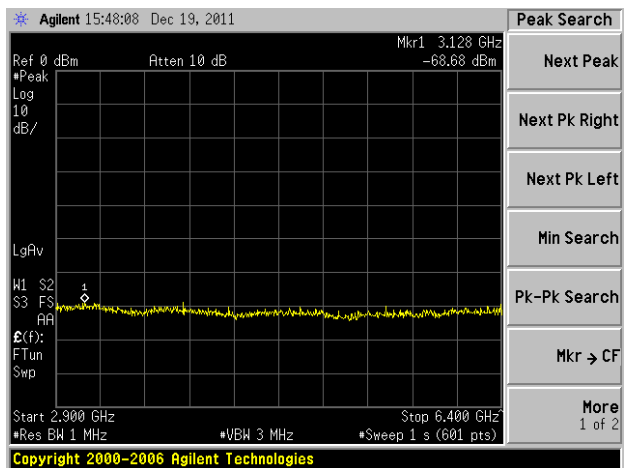

2.9GHz to 6.4GHz

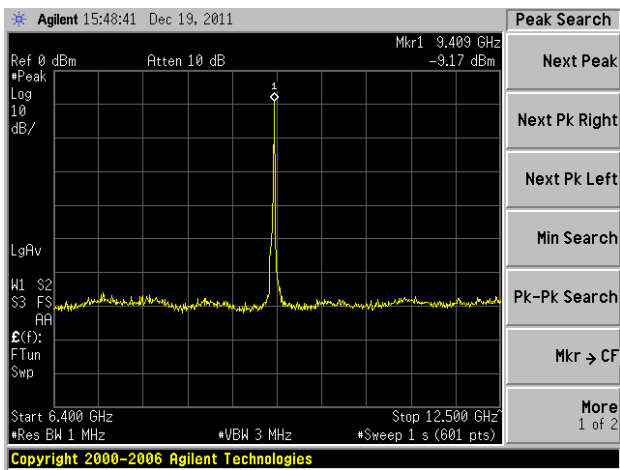

6.4GHz to 12.5GHz

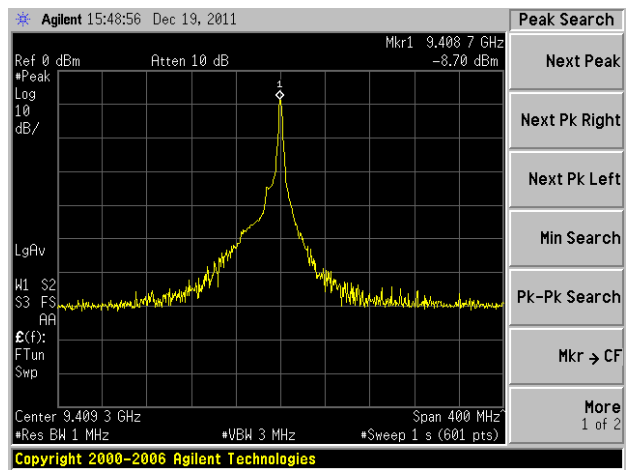

Center 9408.7MHz, Span 400MHz

4.2.2.1 TEST SETUP for range 12.5GHz to 18.0GHz

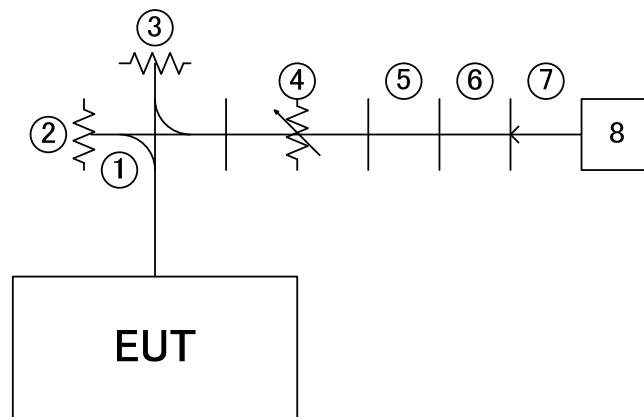

4.2.2.2 TEST INSTRUMENT

	DESCRIPTION & MANUFACTURER	MODEL NO.	SERIAL NO.	CALIBRATION DATE	CALIBRATION DUE DATE
1	Direction Coupler (30dB) SHIMADARIKA	5D363	R11421	NA	NA
2	Dummy Load PASTERNAK	PE6815	NA	NA	NA
3	High Power Dummy Load PASTERNAK	PE6824	NA	NA	NA
4	Variable Attenuator HP	X382A	13681	Jan. 21. 2011	Jan. 2012
5	Tapered Waveguide ATM	62/90-6-6-6	G239605-02	NA	NA
6	Adaptor MDL	62AC126	0622	NA	NA
7	Coaxial Cable HUBER+SUHNER	SUCOFLEX 104	NA	NA	NA
8	Spectrum Analyzer Agilent	E4448A	MY46180420	Oct. 31. 2011	Oct. 2012

Measurement Point : Antenna terminal

Spectrum Analyzer setting: RBW = 1MHz

VBW = 3MHz

Detector Mode = Positive Peak

4.2.2.3 TEST PROCEDURES

- a. Setup EUT as 4.2.2.1.
- b. Transmitted at most powerful pulse and adjusted attenuator for not exceeding the spectrum analyzer maximum rating.
- c. Transmitted at seven pulses are 0.08us/4000Hz, 0.08us/2250Hz, 0.13us/1700Hz, 0.25us/1700Hz, 0.5us/1200Hz, 0.8us/750Hz, 1.0us/650Hz, and capture the spectrum at 12.5GHz to 18GHz.

4.2.2.4 EUT OPERATING CONDITIONS

- Placed the EUT on the testing table.
- Prepared other computer systems for controlling EUT and placed them outside of testing area.

4.2.2.5 TEST RESULTS

No spurious emissions observed above minimum standard.

Test data is described at section 4.2.2.10

4.2.2.6 TEST CONDITIONS

Tamb = 20°C to 25°C, RHamb = 40% ~ 60%

EUT input = 24 VDC

4.2.2.7 STABILIZATION

EUT energized for 10 minutes minimum.

4.2.2.8 TEST EQUIPMENT

JRC Original – Shielded Room

Other equipment – see test set-ups.

4.2.2.9 DATE

19th Dec., 2011

TESTED BY G. Higuchi

4.2.2.10 TEST RESULTS of 12.5GHz to 18GHz

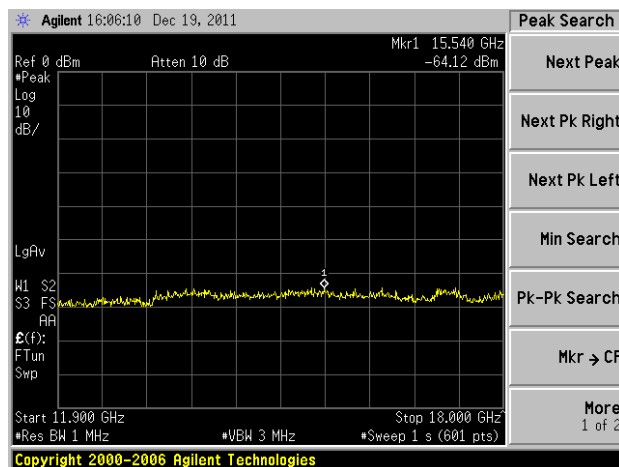

0.08usec/4000Hz

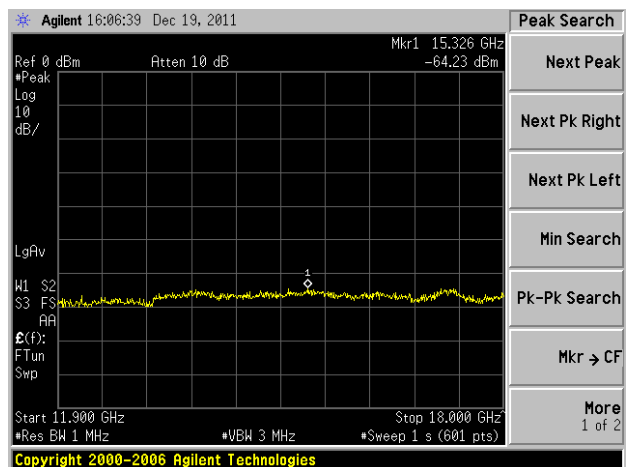

0.08usec/2250Hz

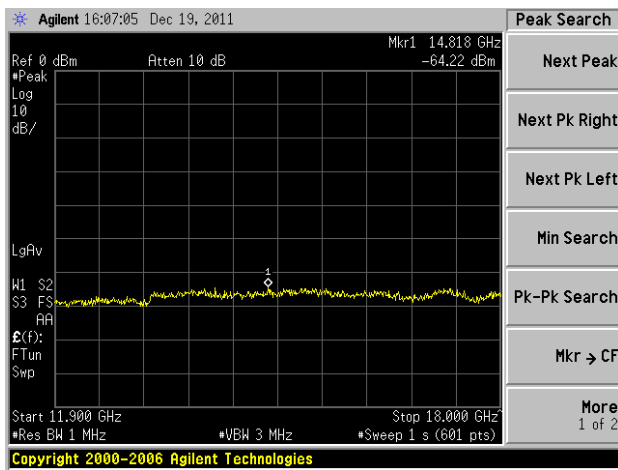

0.13usec/1700Hz

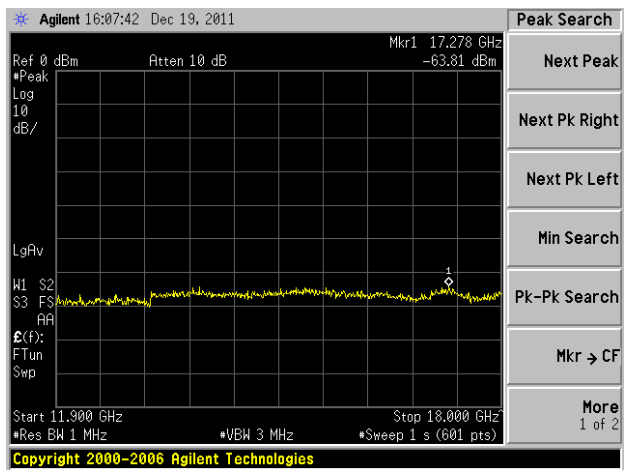

0.25usec/1700Hz

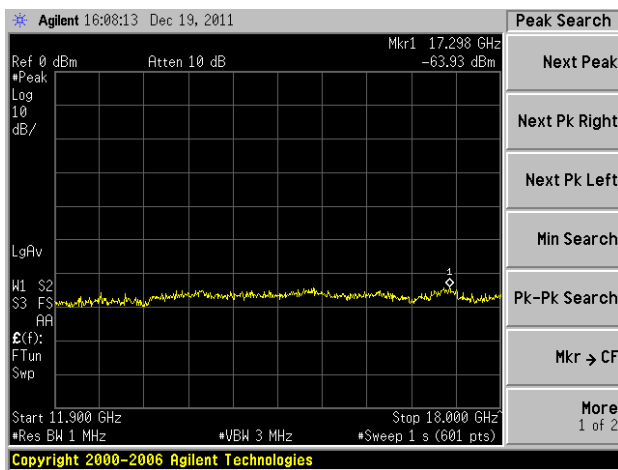

0.50usec/1200Hz

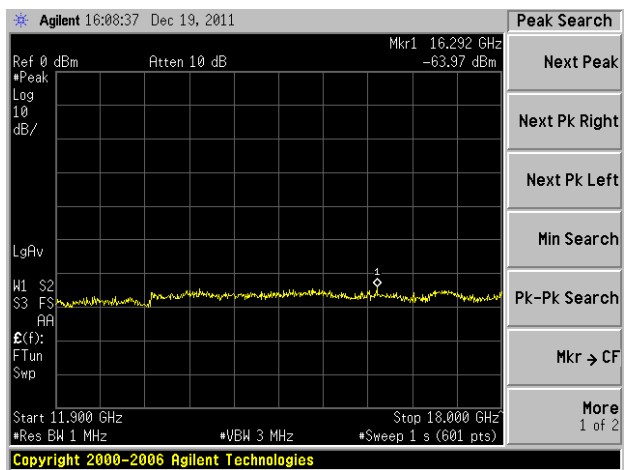

0.8usec/750Hz

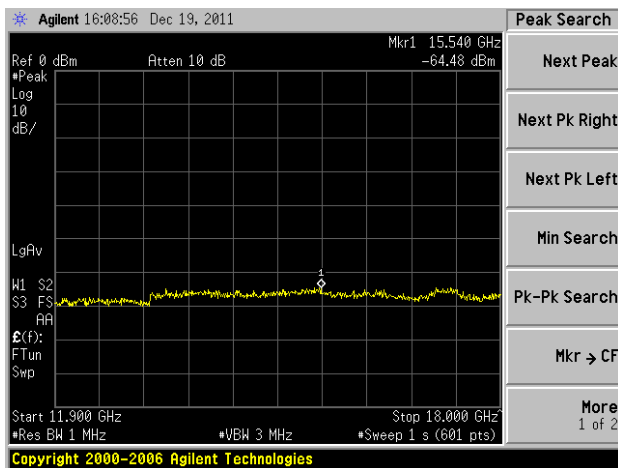

1.0usec/650Hz

4.2.3.1 TEST SETUP for range 17.6GHz to 26.7GHz

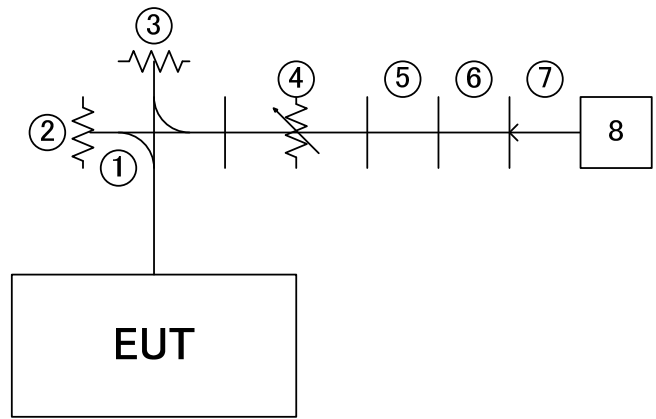

4.2.3.2 TEST INSTRUMENT

	DESCRIPTION & MANUFACTURER	MODEL NO.	SERIAL NO.	CALIBRATION DATE	CALIBRATION DUE DATE
1	Direction Coupler (30dB) SHIMADARIKA	5D363	R11421	NA	NA
2	Dummy Load PASTERNAK	PE6815	NA	NA	NA
3	High Power Dummy Load PASTERNAK	PE6824	NA	NA	NA
4	Variable Attenuator HP	X382A	13681	Jan. 21. 2011	Jan. 2012
5	Tapered Waveguide ATM	42/90-8-6-6	G239705-02	NA	NA
6	Adaptor MDL	42AC206	0616	NA	NA
7	Coaxial Cable HUBER+SUHNER	SUCOFLEX 100	5784 /4PA	NA	NA
8	Spectrum Analyzer Agilent	E4448A	MY46180420	Oct. 31. 2011	Oct. 2012

Measurement Point : Antenna terminal

Spectrum Analyzer setting: RBW = 1MHz

VBW = 3MHz

Detector Mode = Positive Peak

4.2.3.3 TEST PROCEDURES

- a. Setup EUT as 4.2.3.1.
- b. Transmitted at most powerful pulse and adjusted attenuator for not exceeding the spectrum analyzer maximum rating.
- c. Transmitted at seven pulses are 0.08us/4000Hz, 0.08us/2250Hz, 0.13us/1700Hz, 0.25us/1700Hz, 0.5us/1200Hz, 0.8us/750Hz, 1.0us/650Hz, and capture the spectrum at 17.6GHz to 40.0GHz.

4.2.3.4 EUT OPERATING CONDITIONS

- a. Placed the EUT on the testing table.
- b. Prepared other computer systems for controlling EUT and placed them outside of testing area.

4.2.3.5 TEST RESULTS

No spurious emissions observed above minimum standard.

Test data is described at section 4.2.3.10 to 4.2.3.16

4.2.3.6 TEST CONDITIONS

Tamb = 20°C to 25°C, RHamb = 40% ~ 60%

EUT input = 24 VDC

4.2.3.7 STABILIZATION

EUT energized for 10 minutes minimum.

4.2.3.8 TEST EQUIPMENT

JRC Original – Shielded Room

Other equipment – see test set-ups.

4.2.3.9 DATE

19th Dec., 2011

TESTED BY G. Higuchi

4.2.3.10 TEST RESULTS of 0.08usec/4000Hz

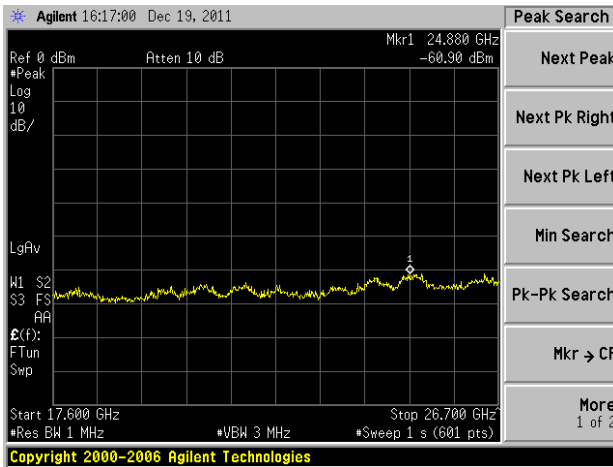

17.6GHz to 26.7GHz

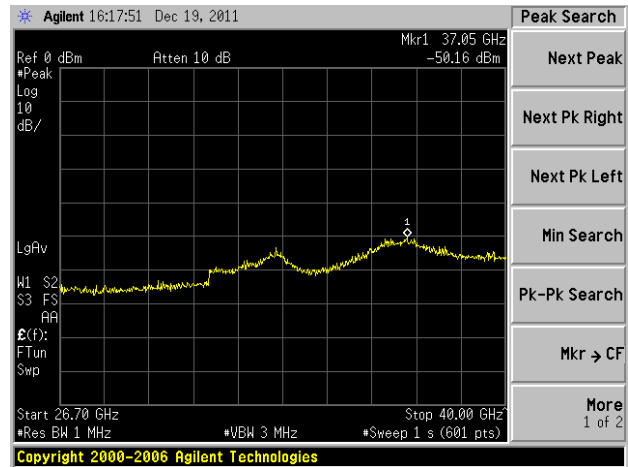

26.7GHz to 40.0GHz

4.2.3.11 TEST RESULTS of 0.08usec/2250Hz

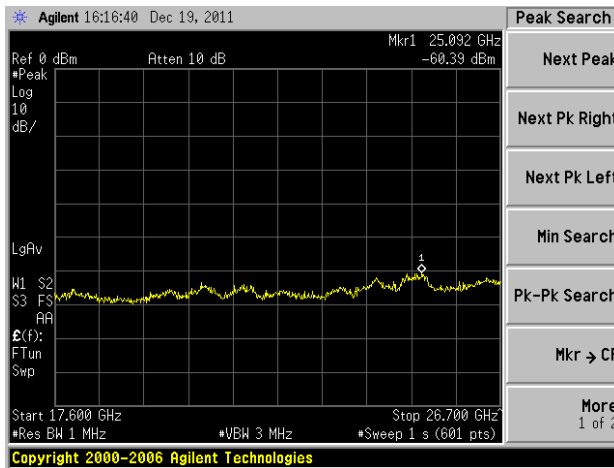

17.6GHz to 26.7GHz

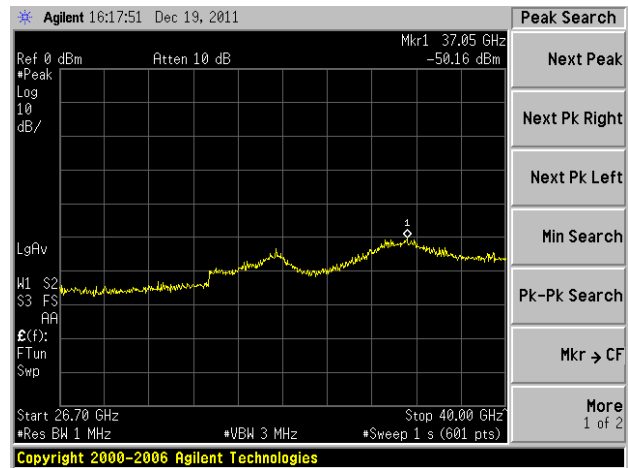

26.7GHz to 40.0GHz

4.2.3.12 TEST RESULTS of 0.13usec/1700Hz

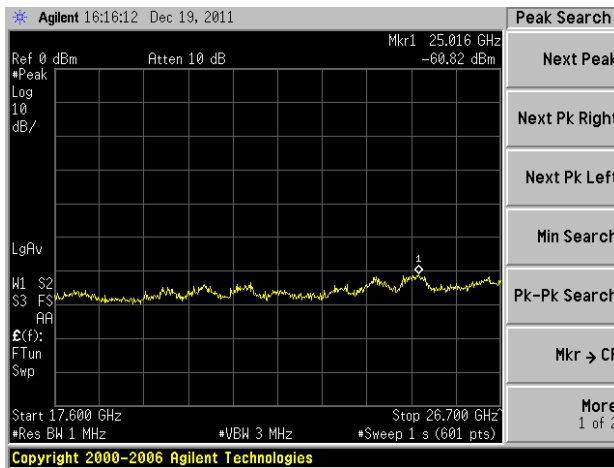

17.6GHz to 26.7GHz

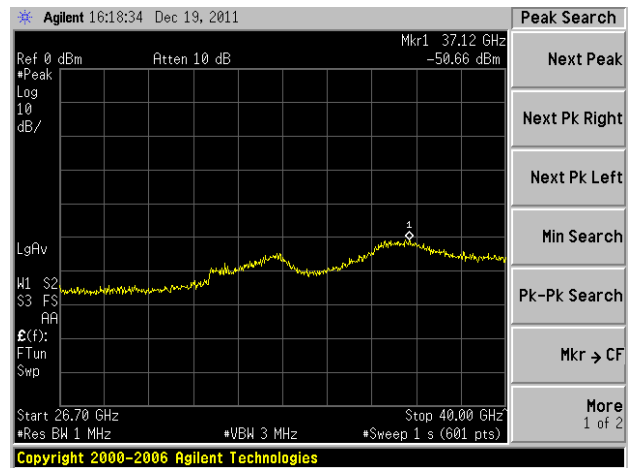

26.7GHz to 40.0GHz

4.2.3.13 TEST RESULTS of 0.25usec/1700Hz

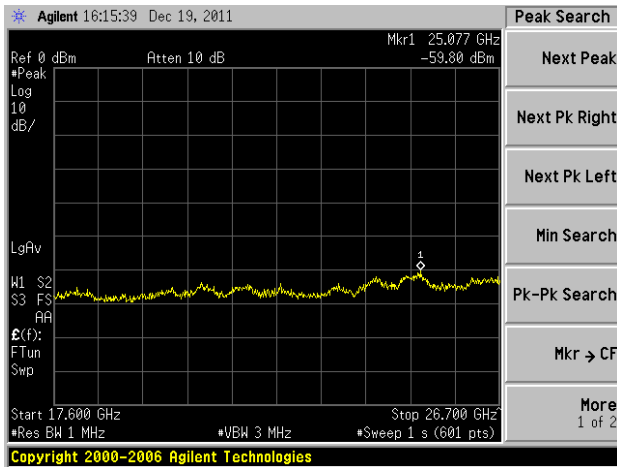

17.6GHz to 26.7GHz

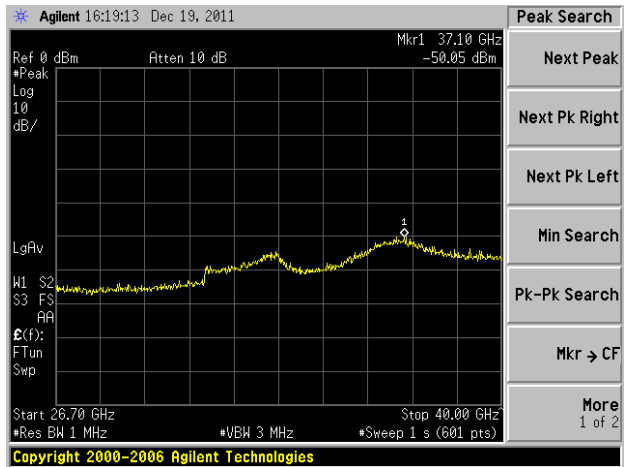

26.7GHz to 40.0GHz

4.2.3.14 TEST RESULTS of 0.5usec/1200Hz

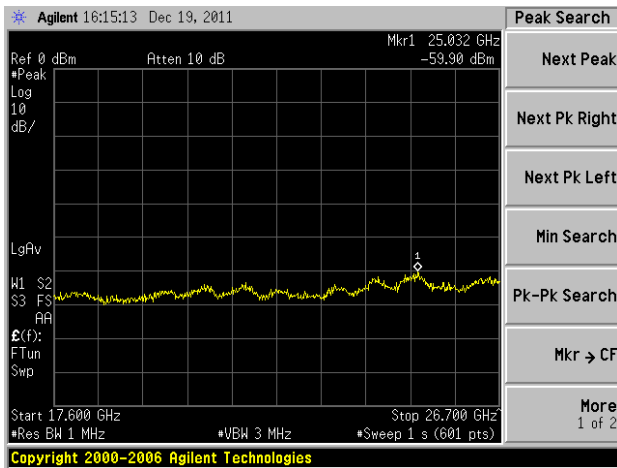

17.6GHz to 26.7GHz

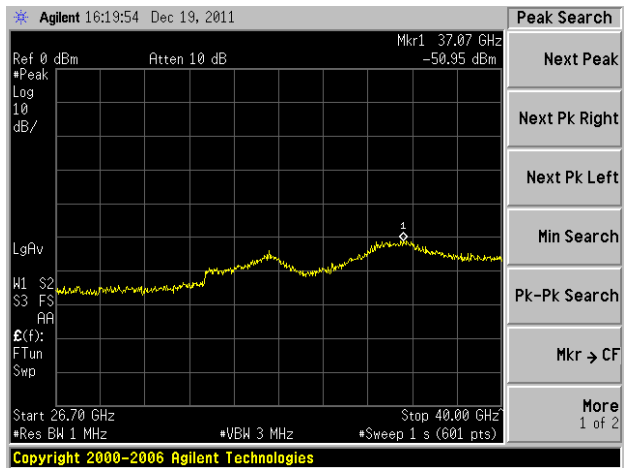

26.7GHz to 40.0GHz

4.2.3.15 TEST RESULTS of 0.8usec/750Hz

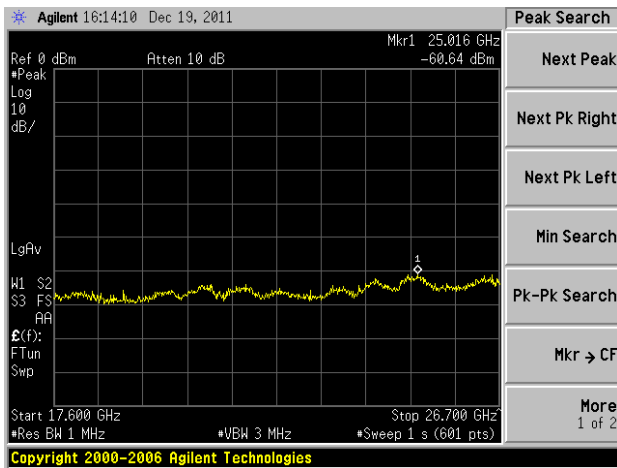

17.6GHz to 26.7GHz

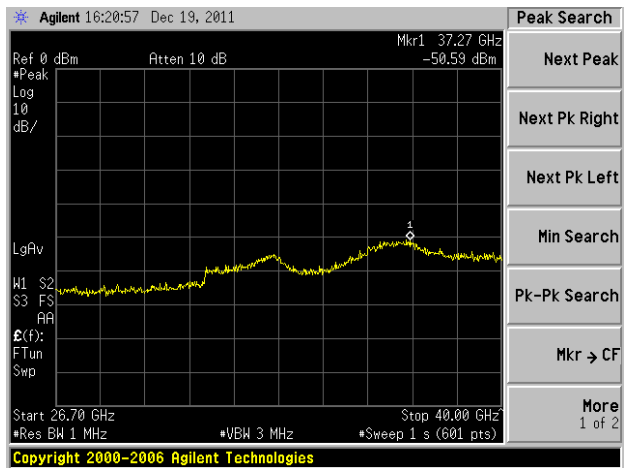

26.7GHz to 40.0GHz

4.2.3.16 TEST RESULTS of 1.0usec/650Hz

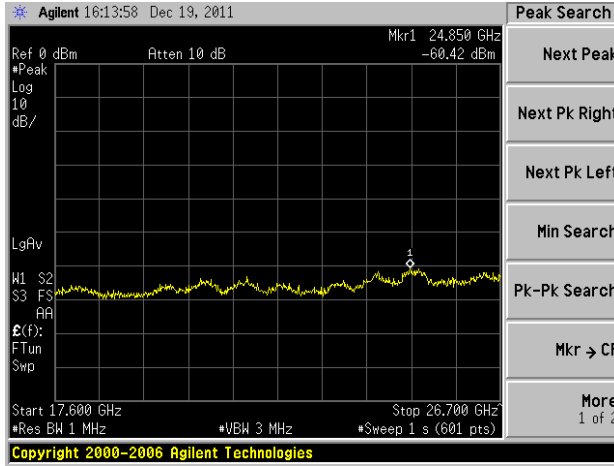

17.6GHz to 26.7GHz

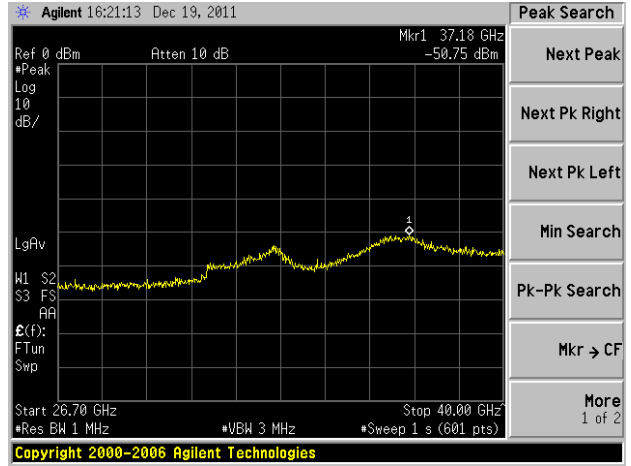

26.7GHz to 40.0GHz

4.3 Field strength of spurious radiation

47 CFR sec. 2.1053

4.3.1.1 TEST SETUP for measuring the radiated spurious emissions are from the EUT.

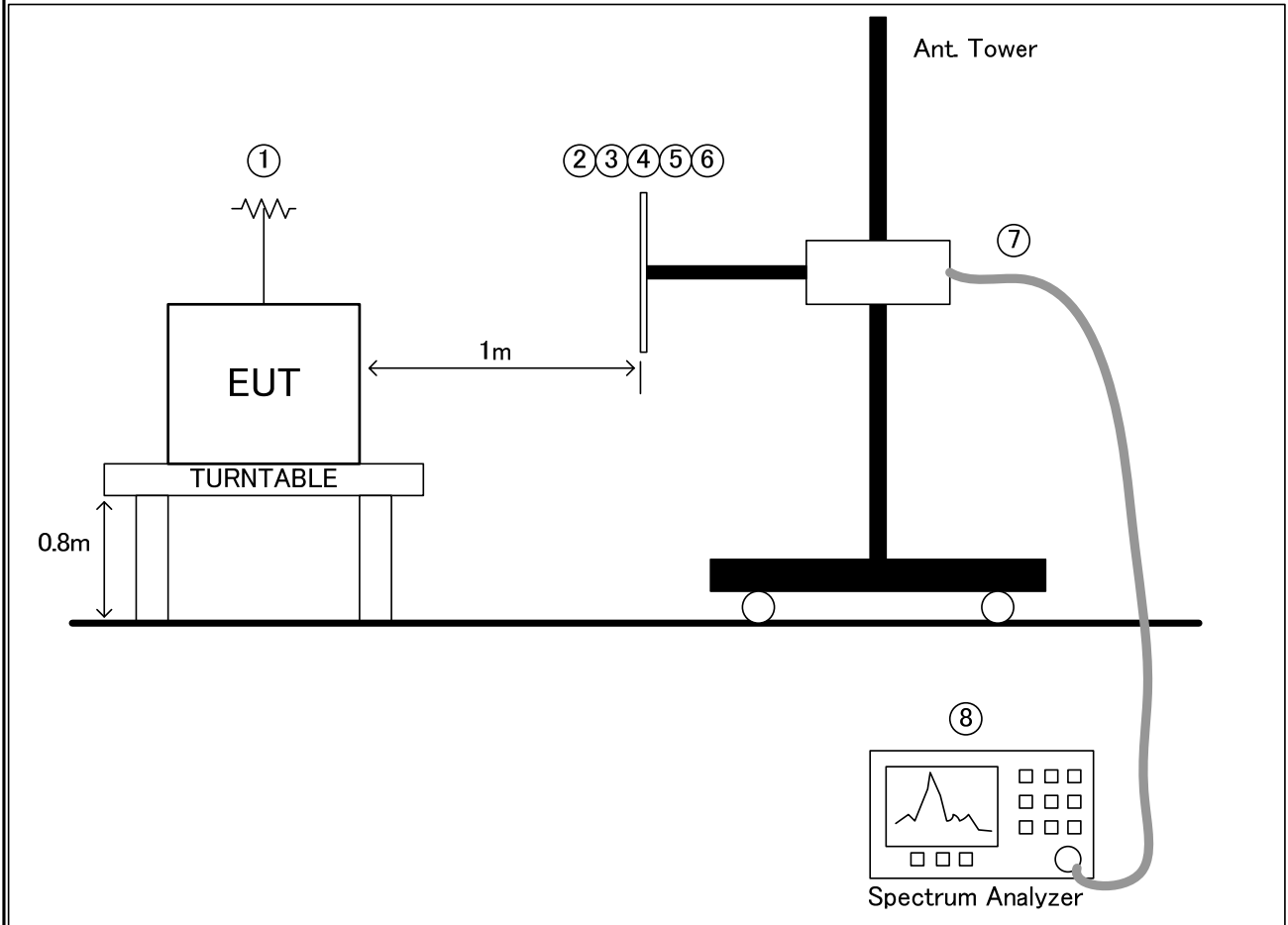

4.3.1.2 TEST INSTRUMENT

	DESCRIPTION & MANUFACTURER	MODEL NO.	SERIAL NO.	CALIBRATION DATE	CALIBRATION DUE DATE
1	High Power Dummy Load PASTERNAK	PE6824	1005-00684	NA	NA
2	Biconical Schwarzbeck	BBA9106	VHA91031979	Apr. 25 th 2011	Apr. 2012
3	Logarithmic Periodic Schwarzbeck	UHALP9107	91071314	July 22 nd 2011	July 2012
4	Double Ridge Horn ETS LINDGREN	3117	00091928	Sep. 28 th 2011	Sep. 2012
5	Standard Gain Horn Flann	20240	NA	NA	NA
6	Standard Gain Horn Flann	22240	NA	NA	NA

7	Coaxial Cable HUBER+SUHNER	SUCOFLEX 100	NA	NA	NA
8	Spectrum Analyzer Agilent	E4448A	MY46180420	Oct. 31 st 2011	Oct.. 2012

4.3.2.1 TEST SETUP for measuring the level of particular spurious frequency from Signal Generator.

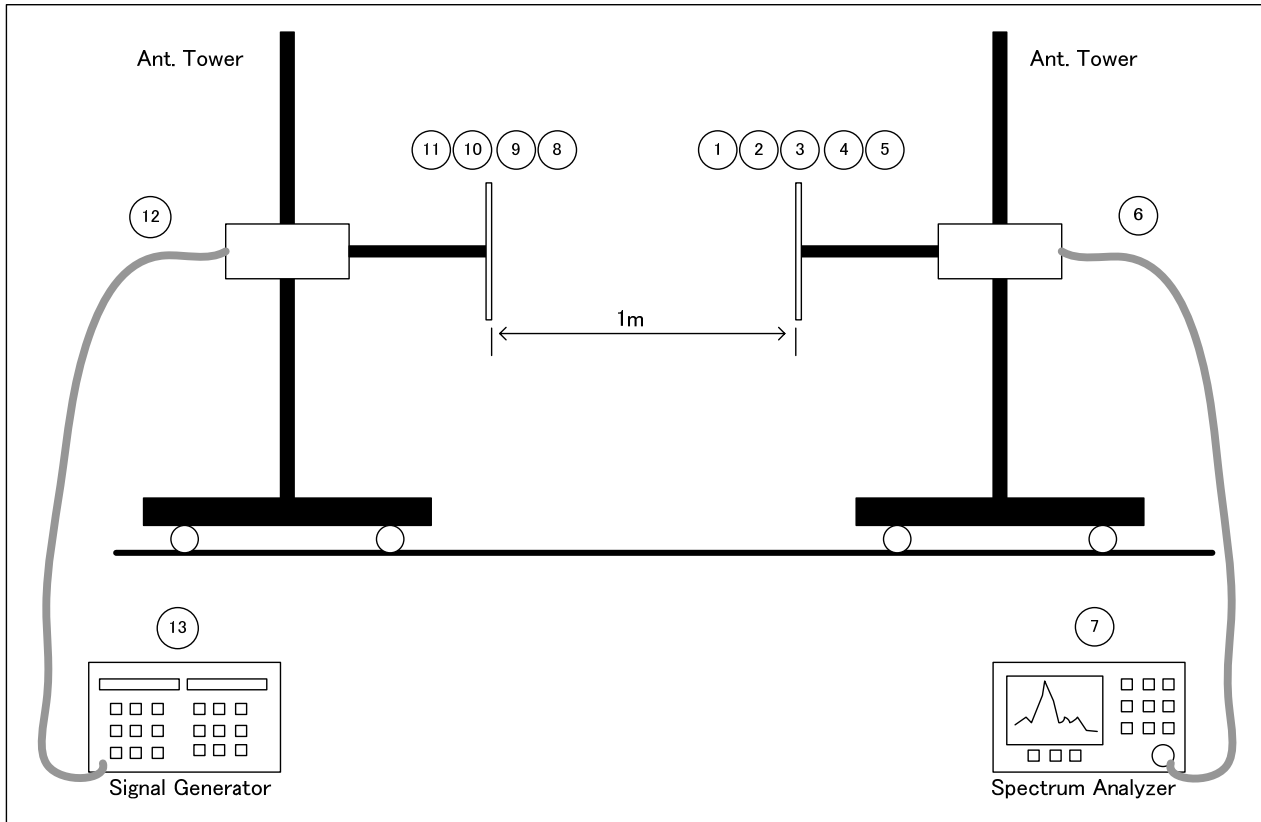

4.3.2.2 TEST INSTRUMENT

	DESCRIPTION & MANUFACTURER	MODEL NO.	SERIAL NO.	CALIBRATION DATE	CALIBRATION DUE DATE
1	Biconical Schwazbeck	BBA9106	VHA91031979	Apr. 25 th 2011	Apr. 2012
2	Logarithmic Periodic Schwazbeck	UHALP9107	91071314	July 22 nd 2011	July 2012
3	Double Ridge Horn ETS LINDGREN	3117	00091928	Sep. 28 th 2011	Sep. 2012
4	Standard Gain Horn Flann	20240	NA	NA	NA
5	Standard Gain Horn Flann	22240	NA	NA	NA
6	Coaxial Cable HUBER+SUHNER	SUCOFLEX 100PA	NA	NA	NA

7	Spectrum Analyzer Agilent	E4448A	MY46180420	Oct. 31 st 2011	Oct.. 2012
8	Dipole Schwazbeck	UHA9105	NA	Feb. 21 st 2011	Feb. 2012
9	Logarithmic Periodic EATON	94612-1	0203	NA	NA
10	Standard Gain Horn Flann	20240	NA	NA	NA
11	Standard Gain Horn Flann	22240	NA	NA	NA
12	Coaxial Cable HUBER+SUHNER	SUCOFLEX 104PA	5994 /4PA	NA	NA
13	Signal Generator Agilent	EE8274C	MY43321154	Sep. 24 th 2011	Sep. 2012

Measurement Point : Antenna terminal

Spectrum Analyzer setting: RBW = 10kHz less than 1GHz, 1MHz above 1GHz

VBW = 300kHz less than 1GHz, 3MHz above 1GHz

Detector Mode = Positive Peak

4.3.3 TEST PROCEDURES

Reference to Section 2.2.12 Unwanted Emission: Radiated Spurious on TIA-603-C.

4.3.4 MINIMUM STANDARD

Frequency < 9300MHz: Emissions < -25dBc

9500MHz < Frequency < 23750MHz: Emissions < -35dBc

Frequency > 23750MHz: Emissions < -47.2dBc

4.3.5 TEST RESULTS

No spurious emissions observed above minimum standard.

Test data is described at section 4.3.10.

4.3.6 TEST CONDITIONS

Tamb = 20°C to 25°C, RHamb = 40% ~ 60%

EUT input = 24 VDC

4.3.7 STABILIZATION

EUT energized for 10 minutes minimum.

4.3.8 TEST EQUIPMENT

JRC Original – Shielded Room

Other equipment – see test set-ups.

4.3.9 DATE

22 December, 2011

TEST ENGINEER: G. Higuchi

4.4.10.1 TEST RESULTS of Dark Noise

Horizontally Polarized Dark noise							
Range	Frequency [MHz]	level [dBm]	Pg [dBm]	Cable Loss [dB]	Antenna Gain [dB]	Pd [dBm]	Radiated Spurious Emission [dBc]
10kHz – 100MHz	47.84	-89.46	-67.0	0.5	-11.48	-79.0	-143.9
100MHz – 200MHz	198.7	-92.37	less than the noise floor	/	/	/	less than the noise floor
200MHz – 300MHz	250	-90.58	less than the noise floor	/	/	/	less than the noise floor
300MHz – 400MHz	375	-88.2	less than the noise floor	/	/	/	less than the noise floor
400MHz – 500MHz	442.3	-91.7	less than the noise floor	/	/	/	less than the noise floor
500MHz – 600MHz	547.3	-91.09	less than the noise floor	/	/	/	less than the noise floor
600MHz – 700MHz	698.8	-91.46	less than the noise floor	/	/	/	less than the noise floor
700MHz – 800MHz	721.7	-91.88	less than the noise floor	/	/	/	less than the noise floor
800MHz – 900MHz	803.8	-91.93	less than the noise floor	/	/	/	less than the noise floor
900MHz – 1.0GHz	915.8	-91.96	less than the noise floor	/	/	/	less than the noise floor
1.0GHz – 2.9GHz	2517	-69.48	less than the noise floor	/	/	/	less than the noise floor
2.9GHz – 6.4GHz	3017	-67.13	less than the noise floor	/	/	/	less than the noise floor
6.4GHz – 12.5GHz	7112	-65.17	less than the noise floor	/	/	/	less than the noise floor
11.9G – 18GHz	15148	-62.94	less than the noise floor	/	/	/	less than the noise floor
17.6G – 26.7GHz	25001	-59.47	less than the noise floor	/	/	/	less than the noise floor
26.7G – 40.0GHz	37160	-49.89	less than the noise floor	/	/	/	less than the noise floor

Vertically Polarized Dark noise							
Range	Frequency [MHz]	level [dBm]	Pg [dBm]	Cable Loss [dB]	Antenna Gain [dB]	Pd [dBm]	Radiated Spurious Emission [dBc]
10kHz – 100MHz	40.01	-84.93	-46.9	0.5	-15.39	-62.8	-127.7
100MHz – 200MHz	120	-91.32	less than the noise floor	/	/	/	less than the noise floor
200MHz – 300MHz	250	-90.75	less than the noise floor	/	/	/	less than the noise floor
300MHz – 400MHz	314.5	-91.29	less than the noise floor	/	/	/	less than the noise floor
400MHz – 500MHz	455.7	-91.23	less than the noise floor	/	/	/	less than the noise floor
500MHz – 600MHz	525	-91.86	less than the noise floor	/	/	/	less than the noise floor
600MHz – 700MHz	600.7	-91.85	less than the noise floor	/	/	/	less than the noise floor
700MHz – 800MHz	792.7	-91.71	less than the noise floor	/	/	/	less than the noise floor
800MHz – 900MHz	823	-91.65	less than the noise floor	/	/	/	less than the noise floor
900MHz – 1.0GHz	916.2	-91.58	less than the noise floor	/	/	/	less than the noise floor
1.0GHz – 2.9GHz	2520	-69.33	less than the noise floor	/	/	/	less than the noise floor
2.9GHz – 6.4GHz	3291	-67.75	less than the noise floor	/	/	/	less than the noise floor
6.4GHz – 12.5GHz	7112	-64.96	less than the noise floor	/	/	/	less than the noise floor
11.9G – 18GHz	17298	-62.96	less than the noise floor	/	/	/	less than the noise floor
17.6G – 26.7GHz	25077	-59.94	less than the noise floor	/	/	/	less than the noise floor
26.7G – 40.0GHz	37070	-50.04	less than the noise floor	/	/	/	less than the noise floor

·Horizontally Polarized

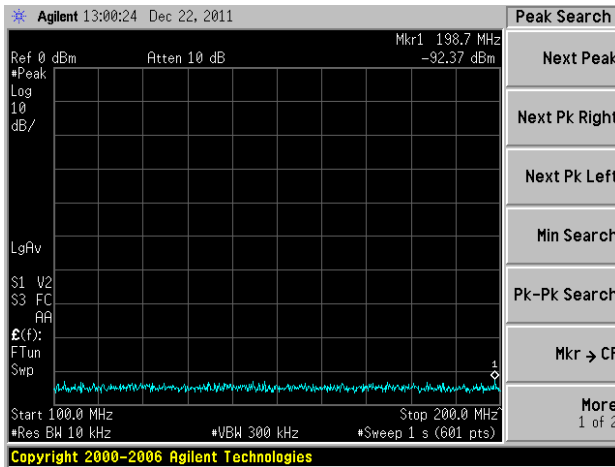

10kHz to 100MHz

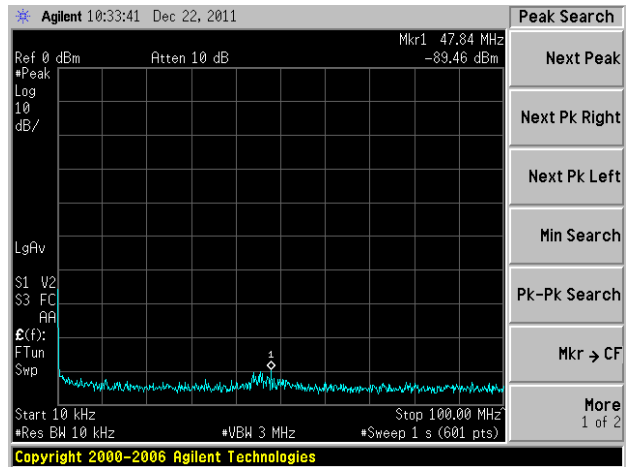

100MHz to 200MHz

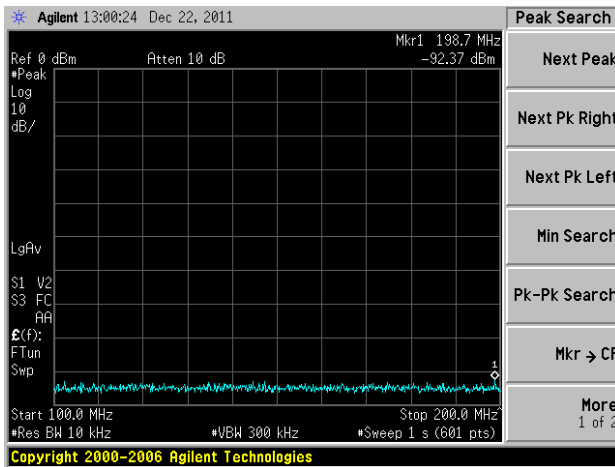

200MHz to 300MHz

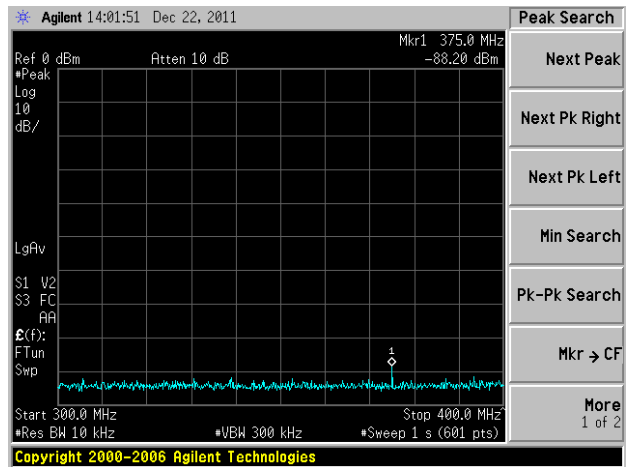

300MHz to 400MHz

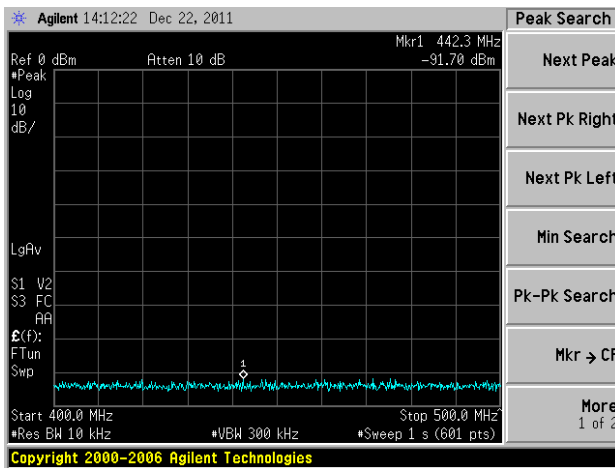

400MHz to 500MHz

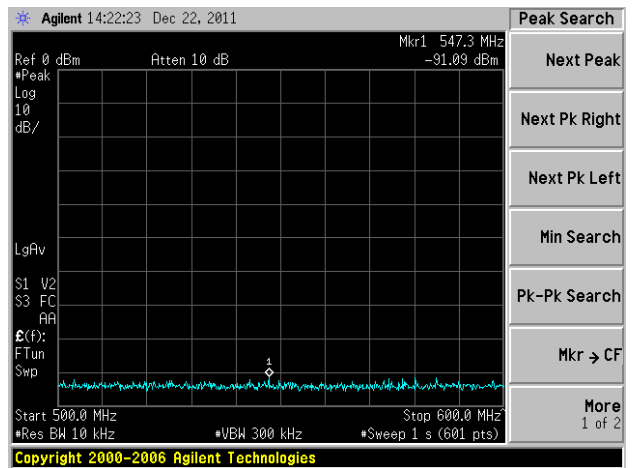

500MHz to 600MHz

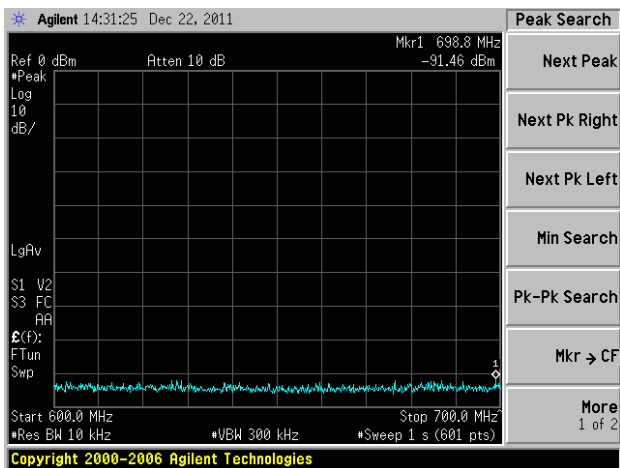

600MHz to 700MHz

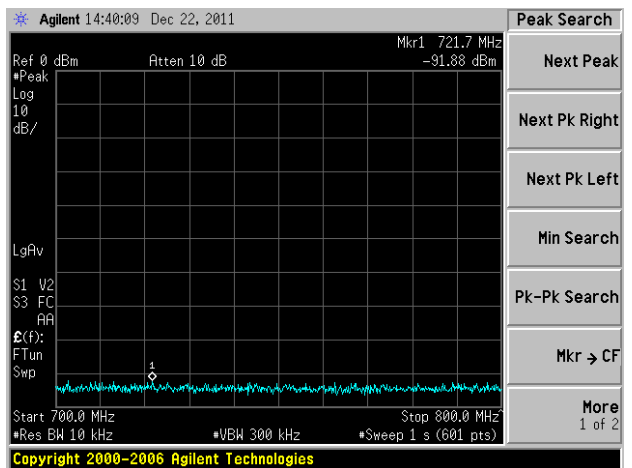

700MHz to 800MHz

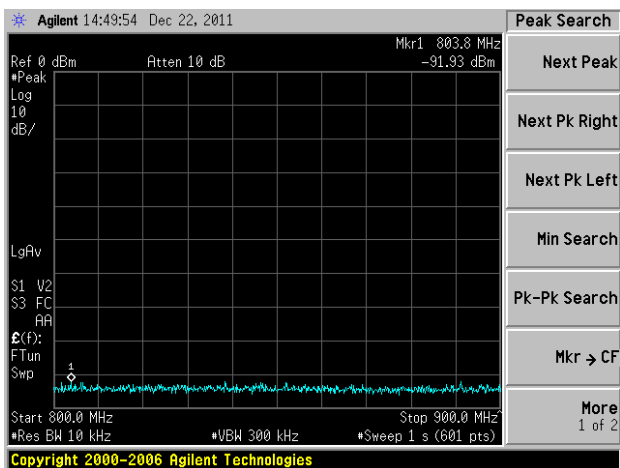

800MHz to 900MHz

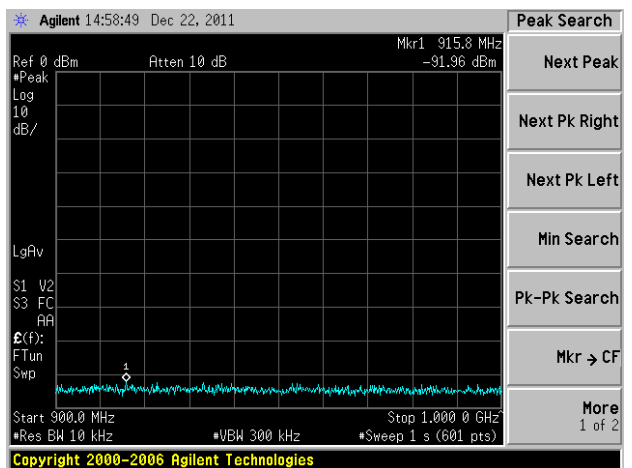

900MHz to 1GHz

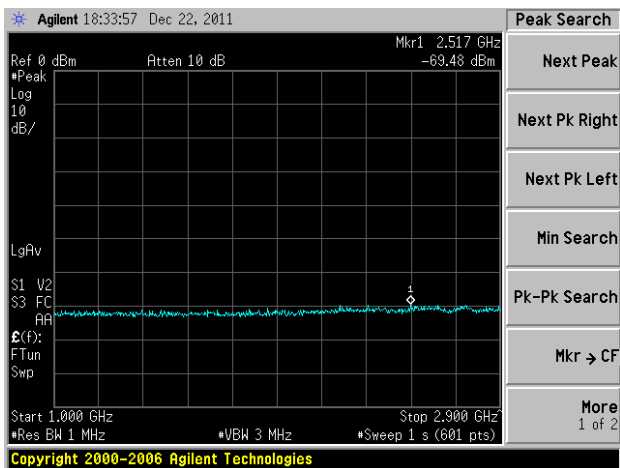

1GHz to 2.9GHz

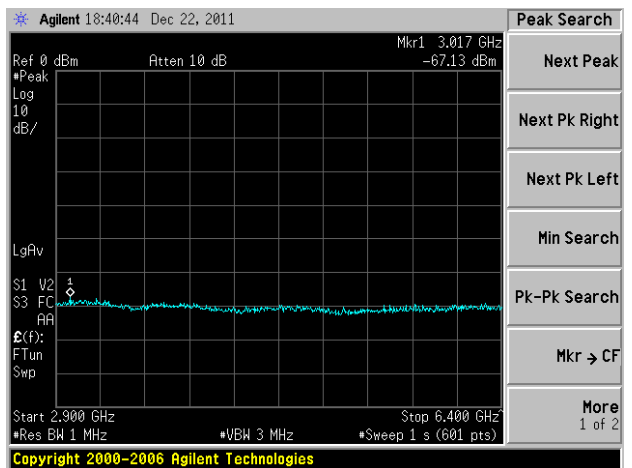

2.9GHz to 6.4GHz

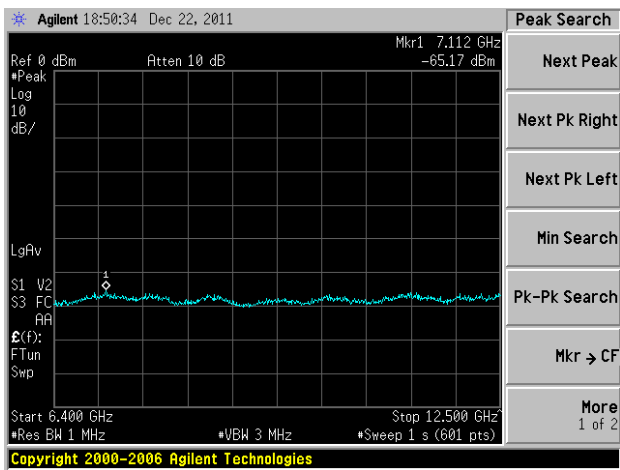

6.4GHz to 12.5GHz

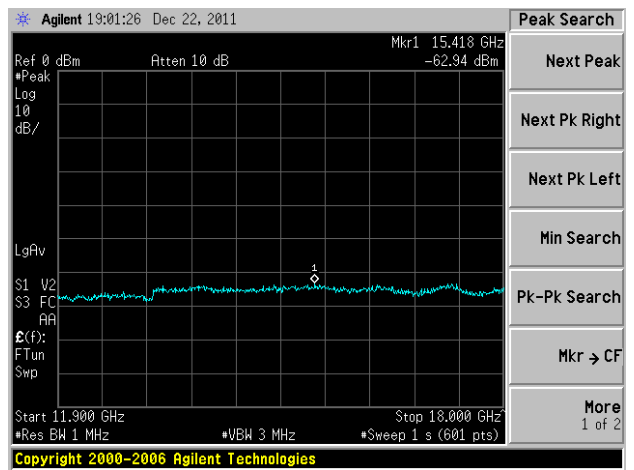

11.9GHz to 18GHz

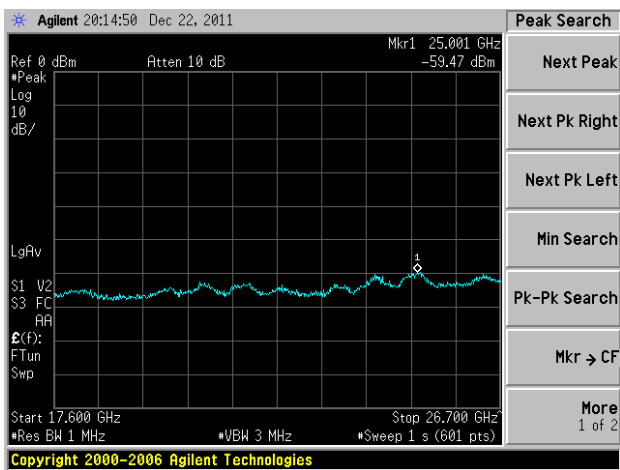

17.6GHz to 26.7GHz

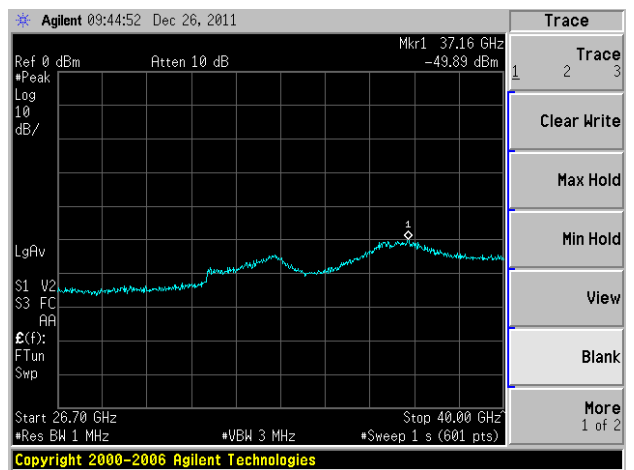

26.5GHz to 40.0GHz

·Vertically Polarized

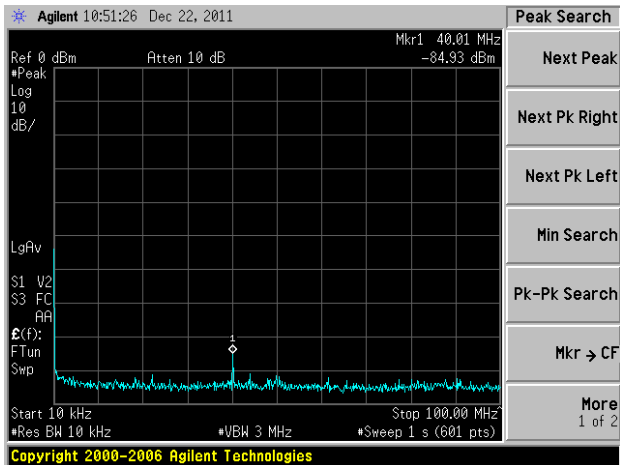

10kHz to 100MHz

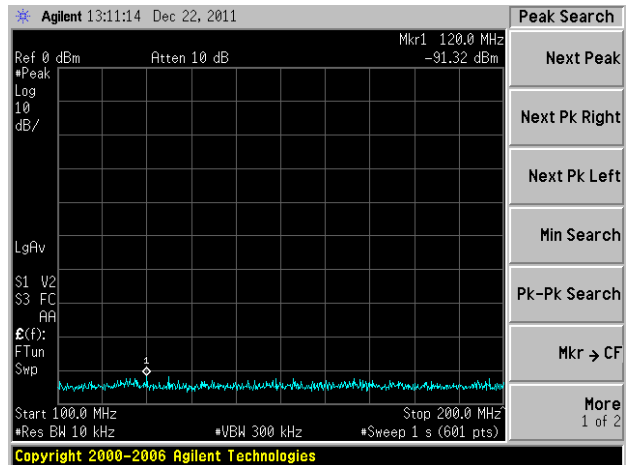

100MHz to 200MHz

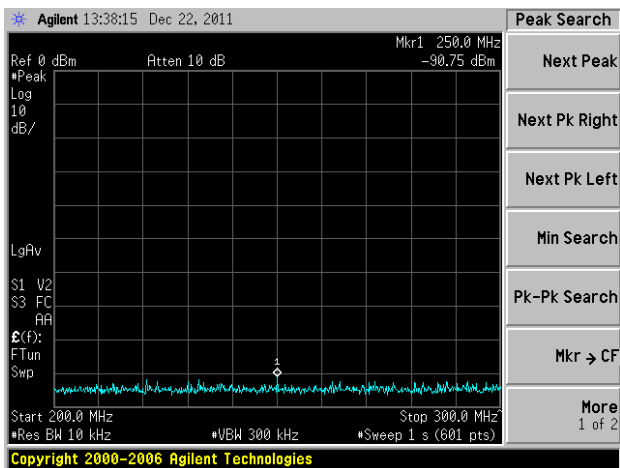

200MHz to 300MHz

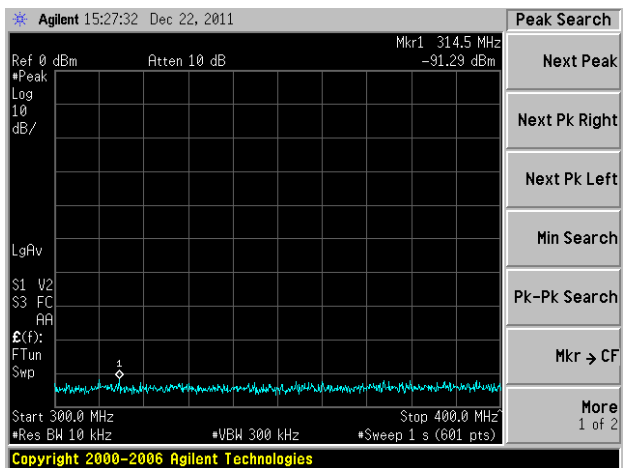

300MHz to 400MHz

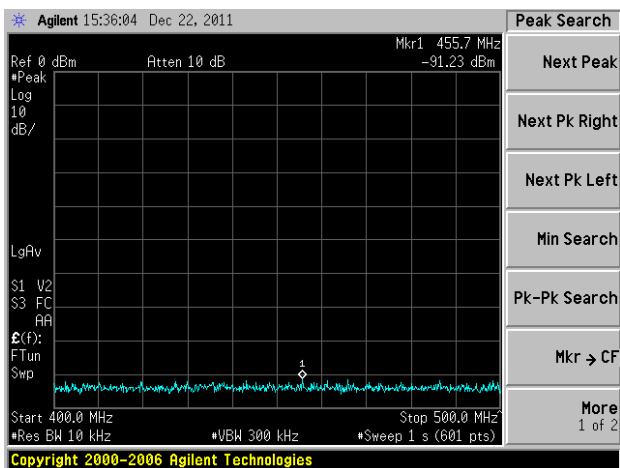

400MHz to 500MHz

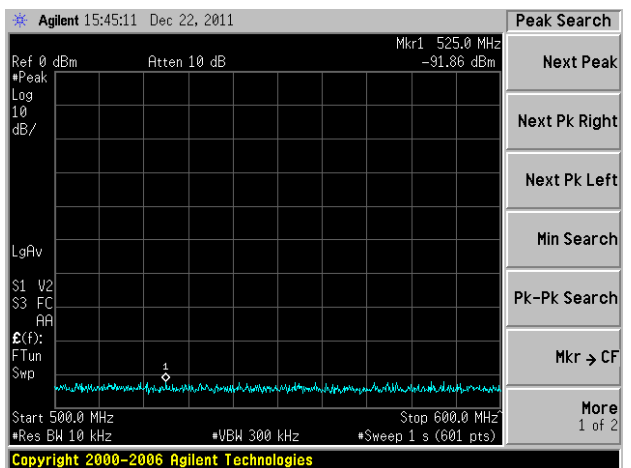

500MHz to 600MHz

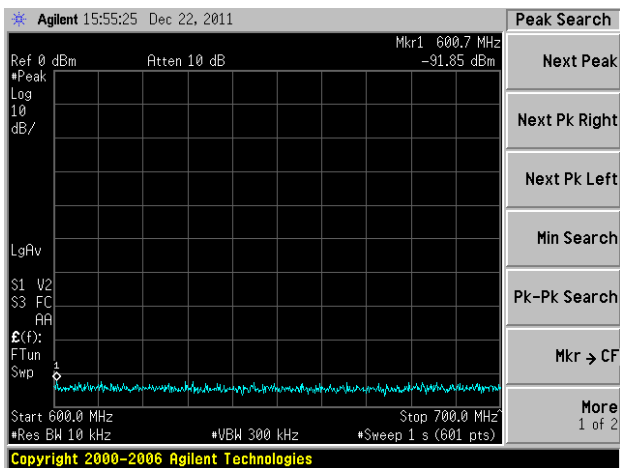

600MHz to 700MHz

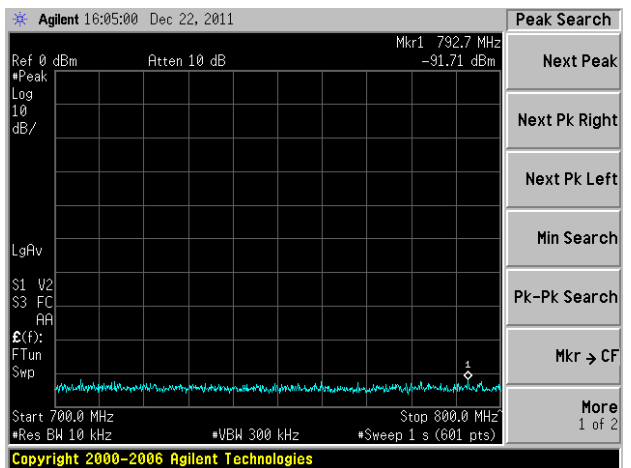

700MHz to 800MHz

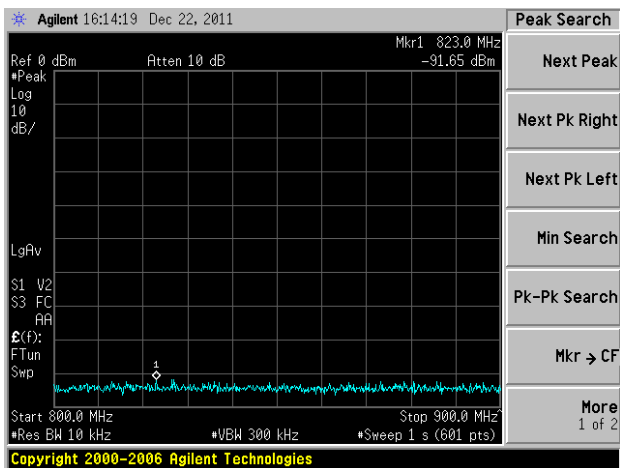

800MHz to 900MHz

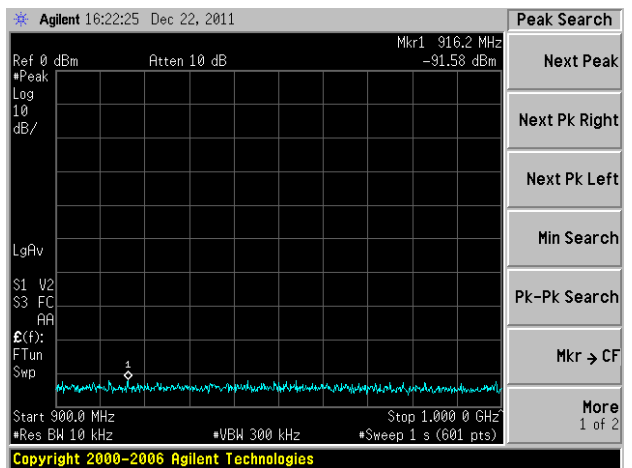

900MHz to 1GHz

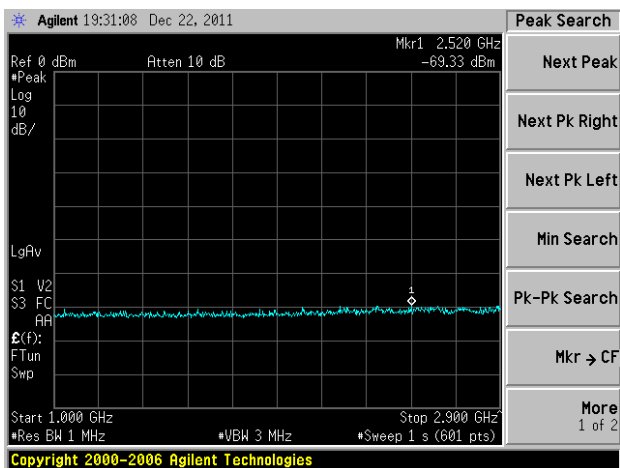

1GHz to 2.9GHz

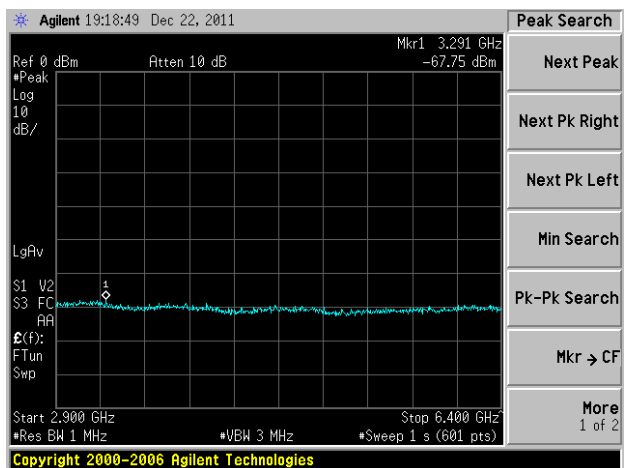

2.9GHz 6.4GHz

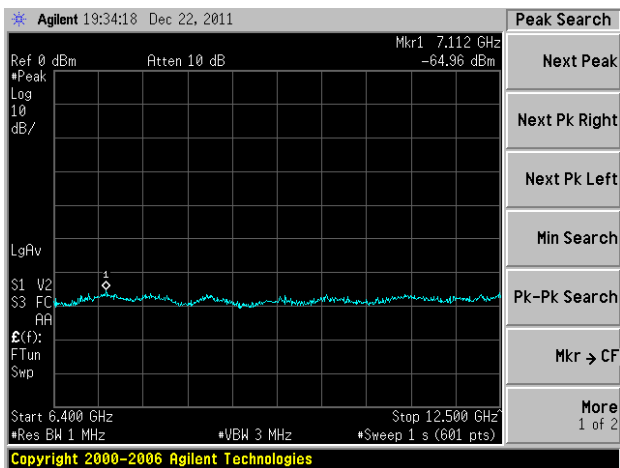

6.4GHz to 12.5GHz

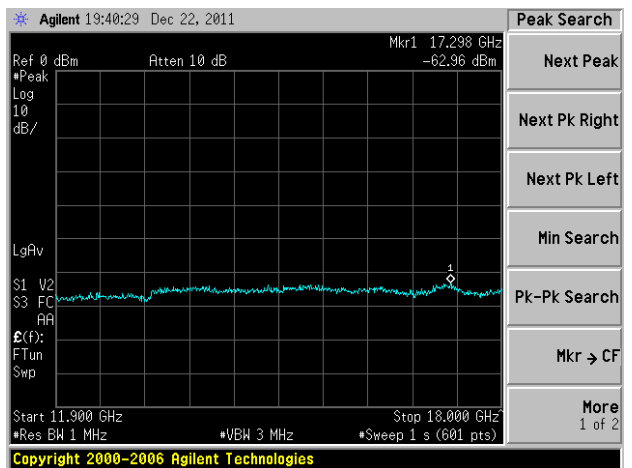

11.9GHz to 18.0GHz

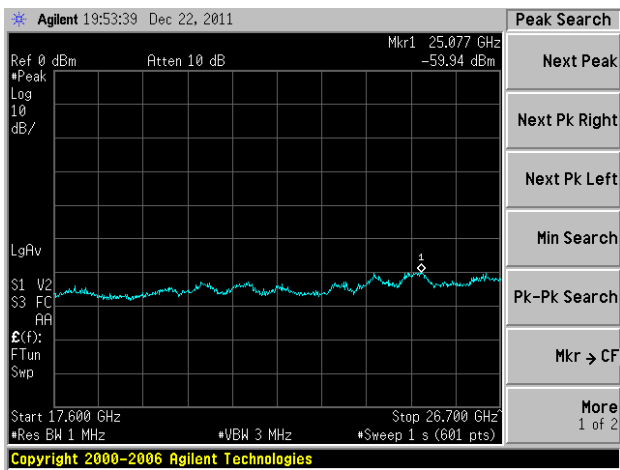

17.6GHz to 26.7GHz

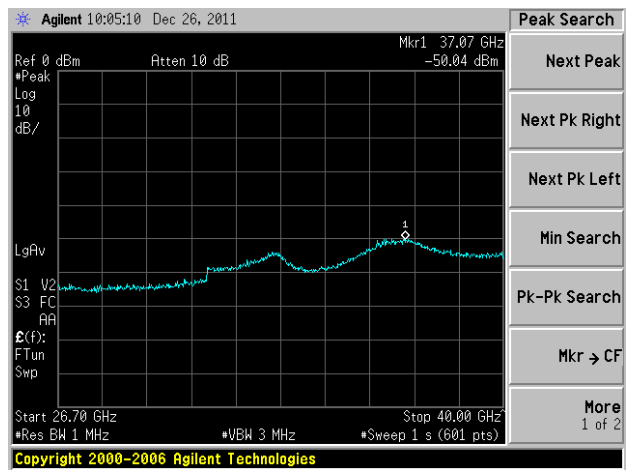

26.4GHz to 40GHz

4.4.10.2 TEST RESULTS of STBY

Horizontally Polarized STBY							
Range	Frequency [MHz]	level [dBm]	Pg [dBm]	Cable Loss [dB]	Antenna Gain [dB]	Pd [dBm]	Radiated Spurious Emission [dBc]
10kHz – 100MHz	47.84	-86.26	-63.8	0.5	-11.48	-75.8	-140.7
100MHz – 200MHz	157.3	-88.82	-73.4	0.5	-4.32	-78.3	-143.2
200MHz – 300MHz	268.3	-85.9	-49.9	0.5	-3.45	-53.9	-118.8
300MHz – 400MHz	314.8	-83.54	-68.5	0.5	2.1	-66.9	-131.9
400MHz – 500MHz	420.5	-88.13	-80	0.5	3.2	-77.3	-142.3
500MHz – 600MHz	511.2	-88.9	-77.5	0.5	3.1	-74.9	-139.9
600MHz – 700MHz	629.2	-92.02	less than the noise floor	/	/	/	less than the noise floor
700MHz – 800MHz	713.8	-91.75	less than the noise floor	/	/	/	less than the noise floor
800MHz – 900MHz	817.7	-92.05	less than the noise floor	/	/	/	less than the noise floor
900MHz – 1.0GHz	947.8	-91.86	less than the noise floor	/	/	/	less than the noise floor
1.0GHz – 2.9GHz	2837	-69.3	less than the noise floor	/	/	/	less than the noise floor
2.9GHz – 6.4GHz	3128	-67.93	less than the noise floor	/	/	/	less than the noise floor
6.4GHz – 12.5GHz	11239	-65.74	less than the noise floor	/	/	/	less than the noise floor
11.9G – 18GHz	13882	-62.85	less than the noise floor	/	/	/	less than the noise floor
17.6G – 26.7GHz	25077	-59.38	less than the noise floor	/	/	/	less than the noise floor
26.7G – 40.0GHz	36850	-49.75	less than the noise floor	/	/	/	less than the noise floor

Vertically Polarized STBY							
Range	Frequency [MHz]	level [dBm]	Pg [dBm]	Cable Loss [dB]	Antenna Gain [dB]	Pd [dBm]	Radiated Spurious Emission [dBc]
10kHz – 100MHz	40.01	-86.5	-48.4	0.5	-15.39	-64.3	-129.3
100MHz – 200MHz	140.3	-86.41	-67.8	0.5	-4.48	-72.8	-137.7
200MHz – 300MHz	267.2	-83.88	-48.9	0.5	-3.45	-52.9	-117.8
300MHz – 400MHz	315.3	-87.45	-74.3	0.5	2.2	-72.6	-137.6
400MHz – 500MHz	405.3	-89.81	-86	0.5	3.2	-83.3	-148.3
500MHz – 600MHz	551.5	-91.87	less than the noise floor	/	/	/	less than the noise floor
600MHz – 700MHz	619.3	-91.88	less than the noise floor	/	/	/	less than the noise floor
700MHz – 800MHz	723.8	-92.44	less than the noise floor	/	/	/	less than the noise floor
800MHz – 900MHz	887	-91.56	less than the noise floor	/	/	/	less than the noise floor
900MHz – 1.0GHz	939.5	-91.37	less than the noise floor	/	/	/	less than the noise floor
1.0GHz – 2.9GHz	2615	-68.75	less than the noise floor	/	/	/	less than the noise floor
2.9GHz – 6.4GHz	3145	-67.72	less than the noise floor	/	/	/	less than the noise floor
6.4GHz – 12.5GHz	7071	-65.71	less than the noise floor	/	/	/	less than the noise floor
11.9G – 18GHz	17187	-63.07	less than the noise floor	/	/	/	less than the noise floor
17.6G – 26.7GHz	24819	-59.89	less than the noise floor	/	/	/	less than the noise floor
26.7G – 40.0GHz	37230	-49.59	less than the noise floor	/	/	/	less than the noise floor

·Horizontally Polarized

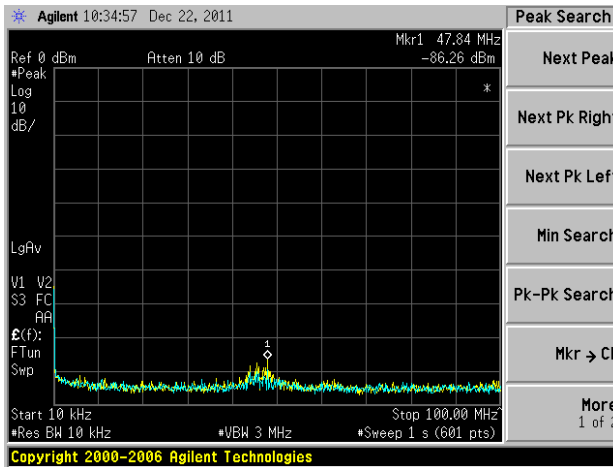

10kHz to 100MHz

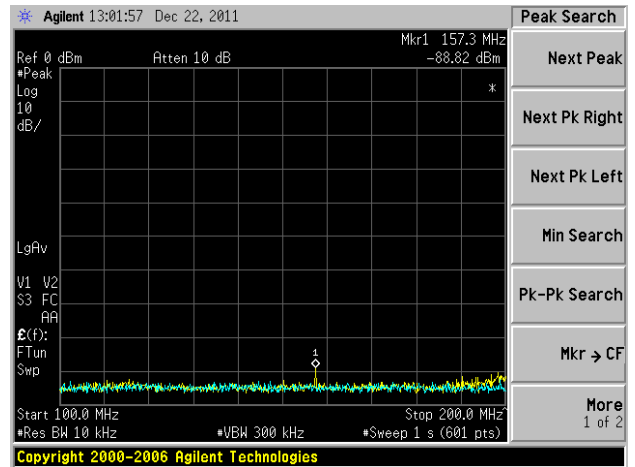

100MHz to 200MHz

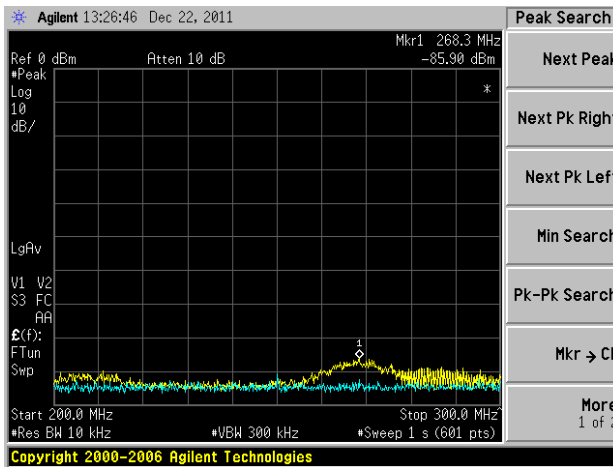

200MHz to 300MHz

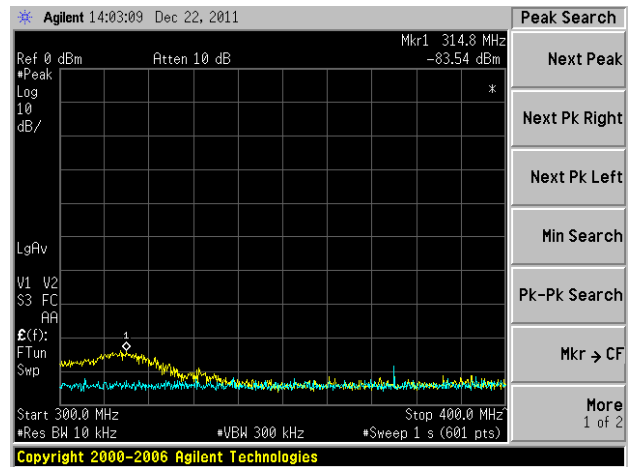

300MHz to 400MHz

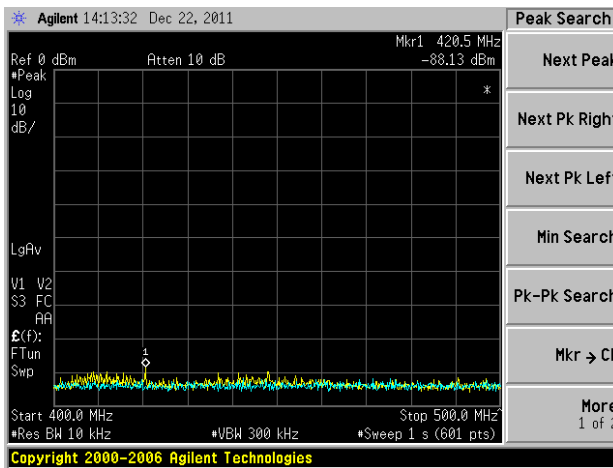

400MHz to 500MHz

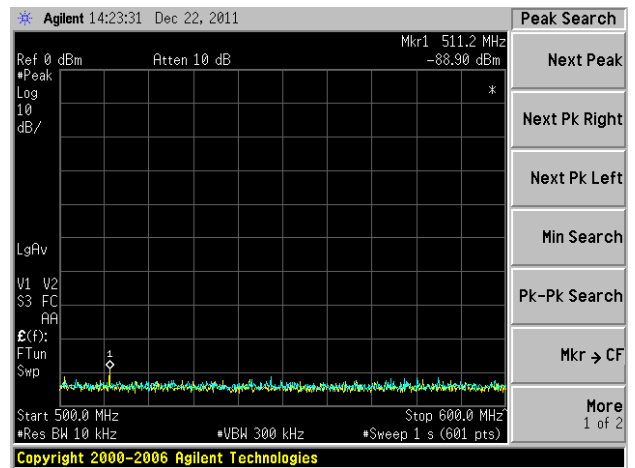

500MHz to 600MHz

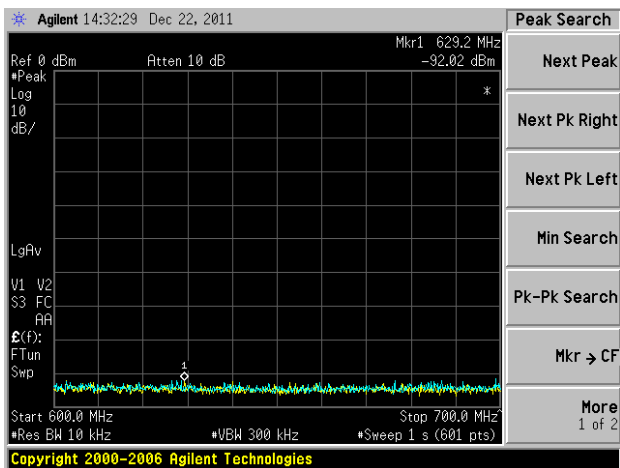

600MHz to 700MHz

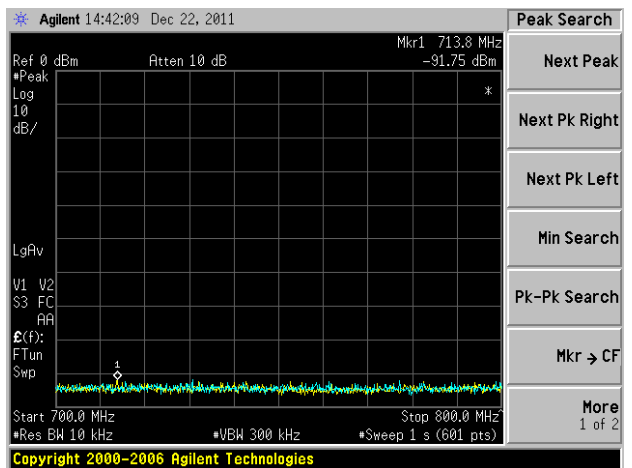

700MHz to 800MHz

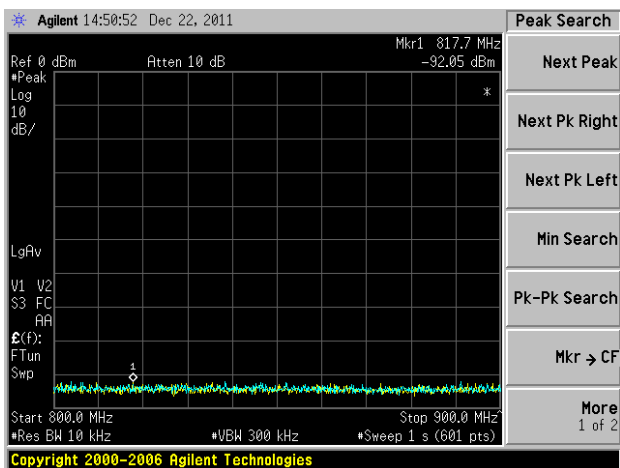

800MHz to 900MHz

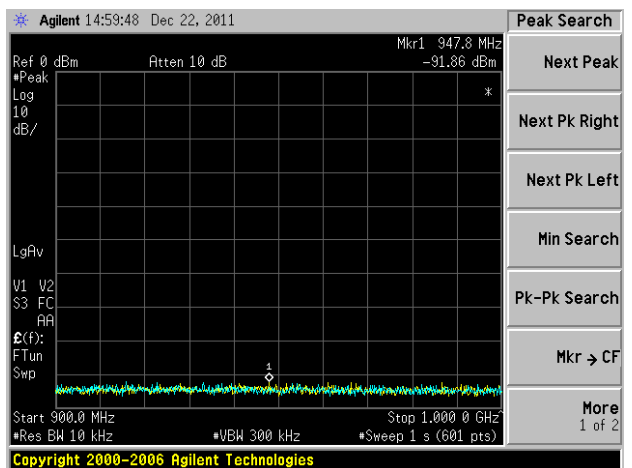

900MHz to 1GHz

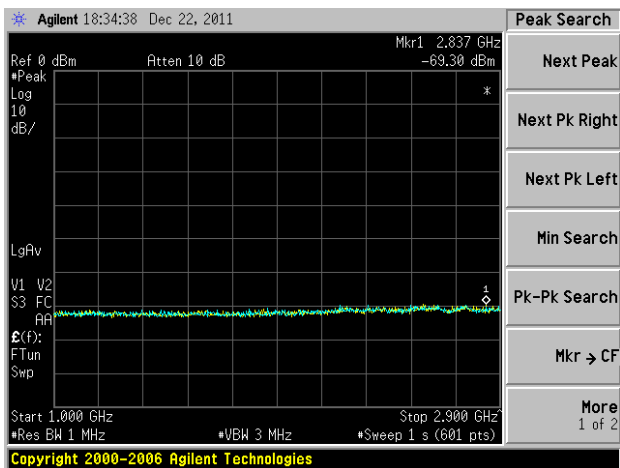

1GHz to 2.9GHz

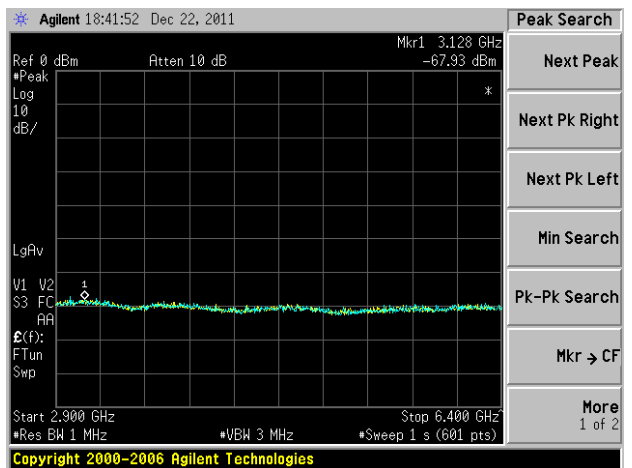

2.9GHz to 6.4GHz

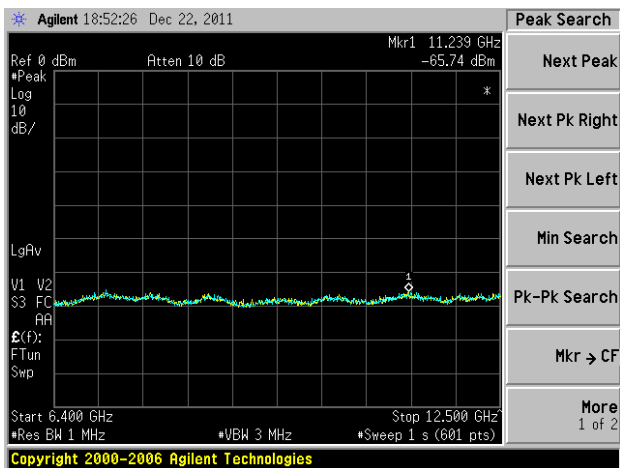

6.4GHz to 12.5GHz

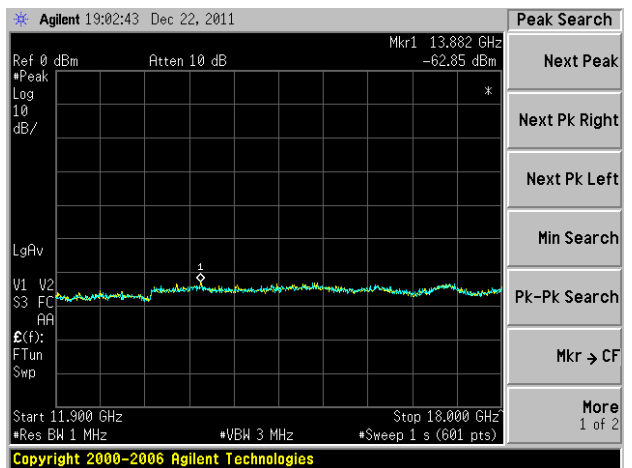

11.9GHz to 18GHz

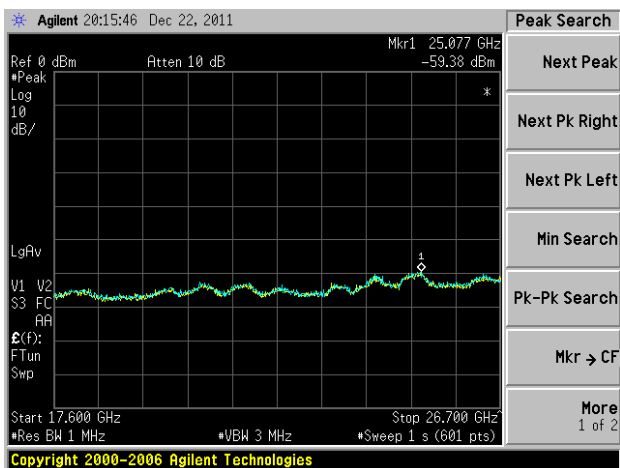

17.6GHz to 26.7GHz

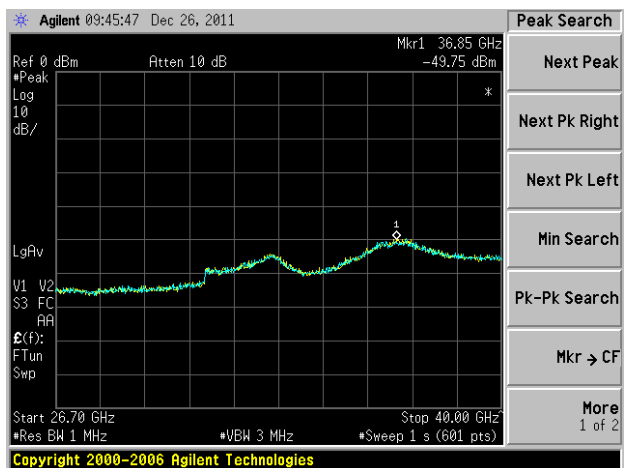

26.5GHz to 40.0GHz

·Vertically Polarized

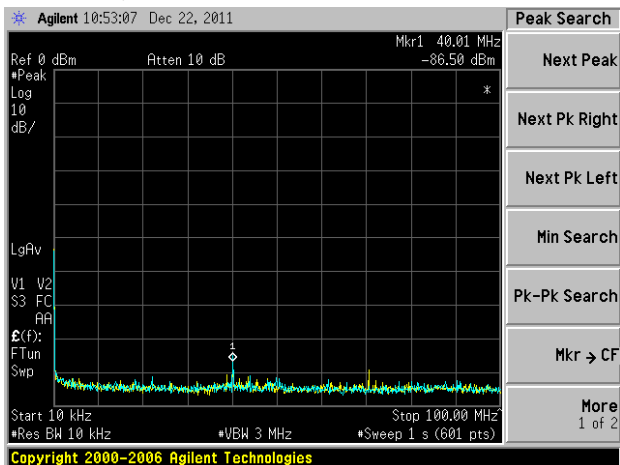

10kHz to 100MHz

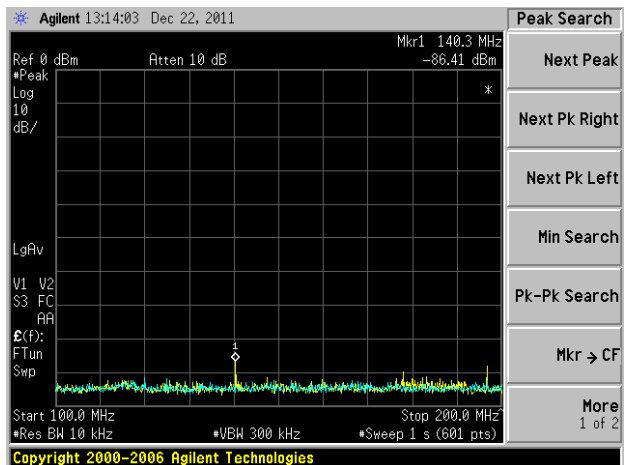

100MHz to 200MHz

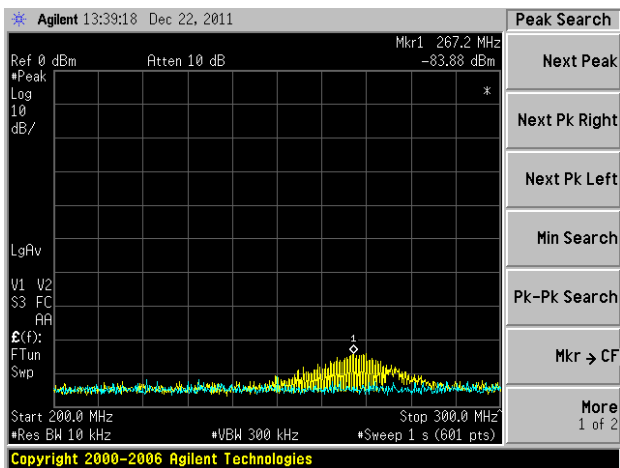

200MHz to 300MHz

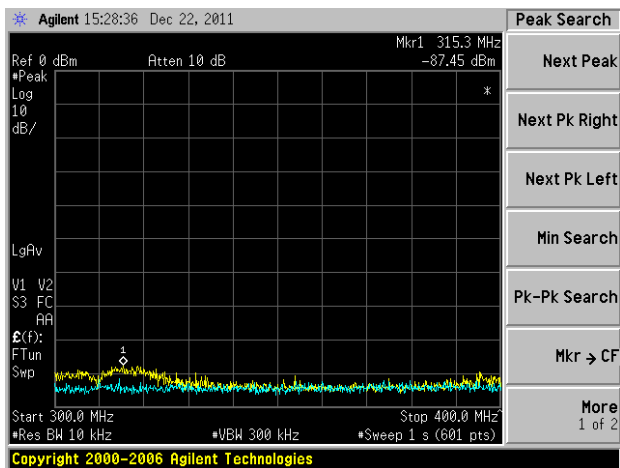

300MHz to 400MHz

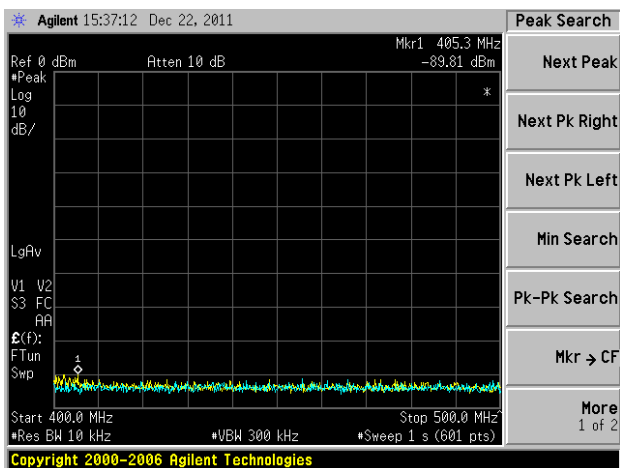

400MHz to 500MHz

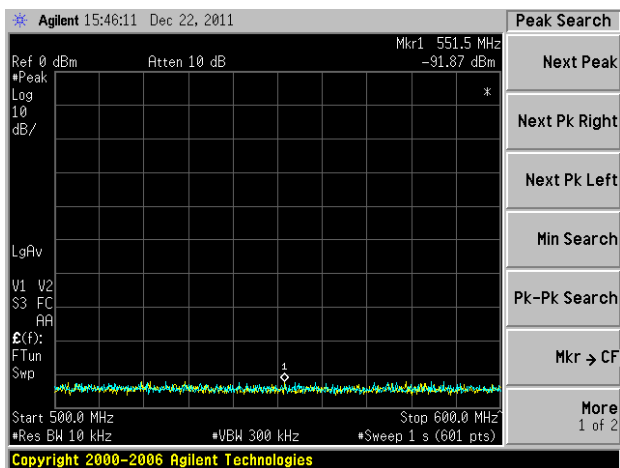

500MHz to 600MHz

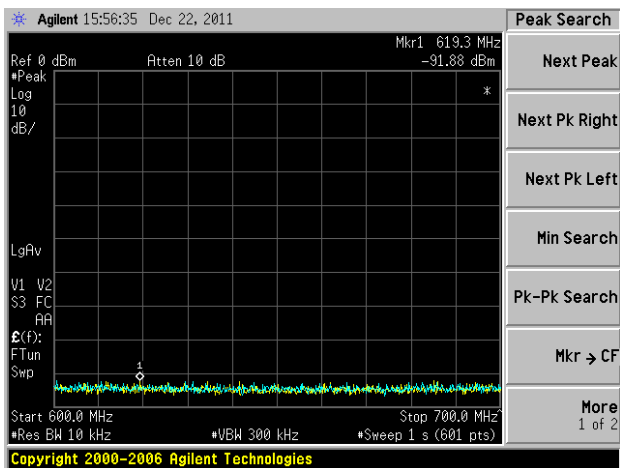

600MHz to 700MHz

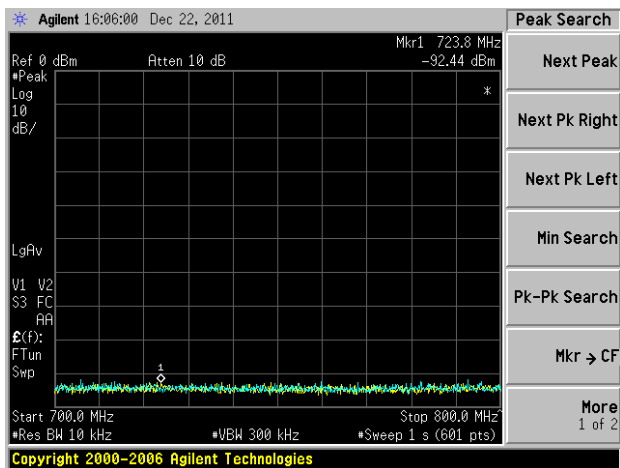

700MHz to 800MHz

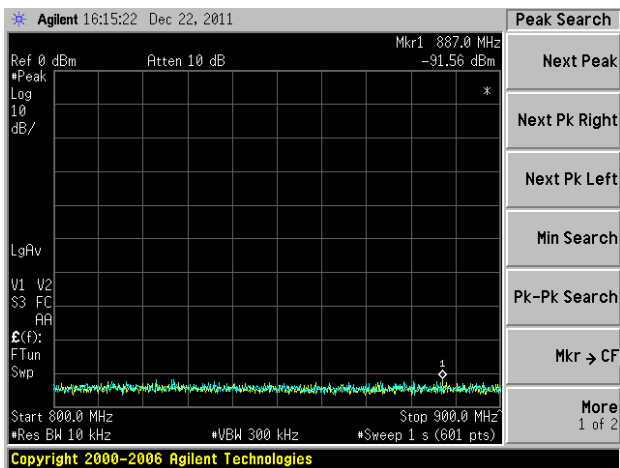

800MHz to 900MHz

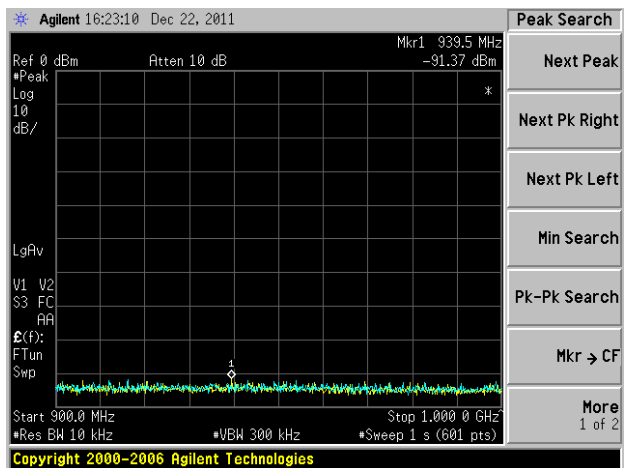

900MHz to 1GHz

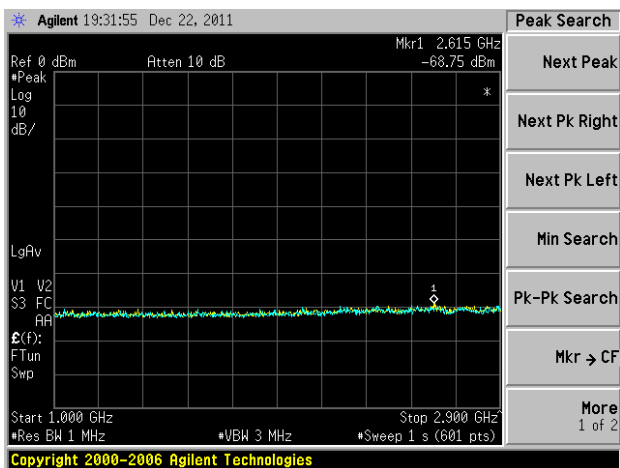

1GHz to 2.9GHz

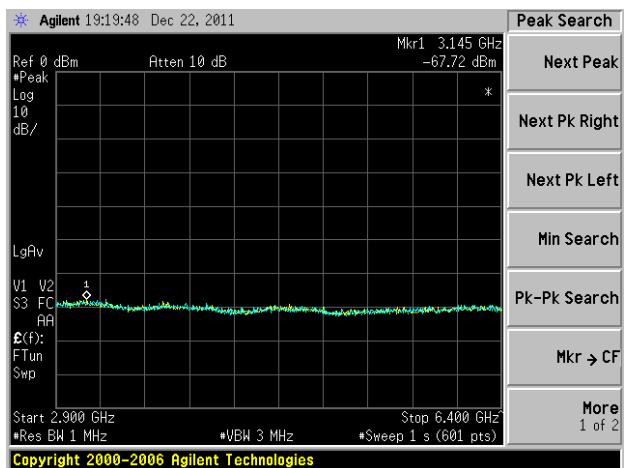

2.9GHz 6.4GHz

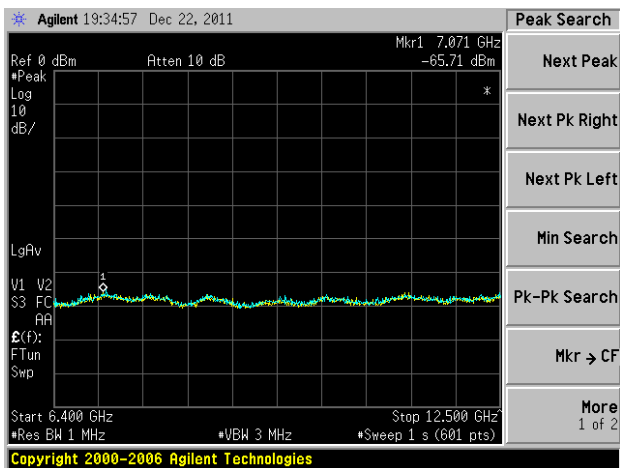

6.4GHz to 12.5GHz

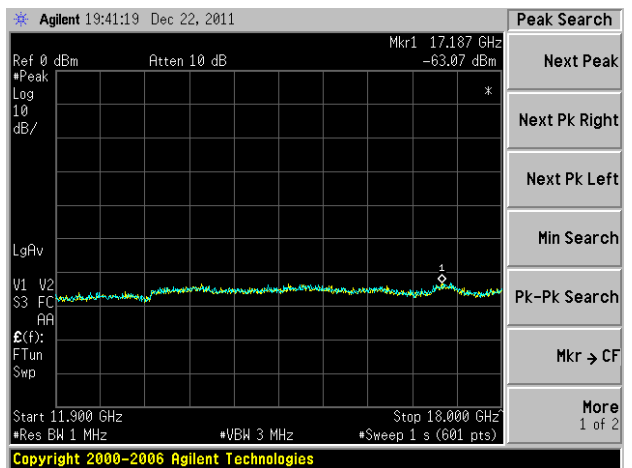

11.9GHz to 18.0GHz

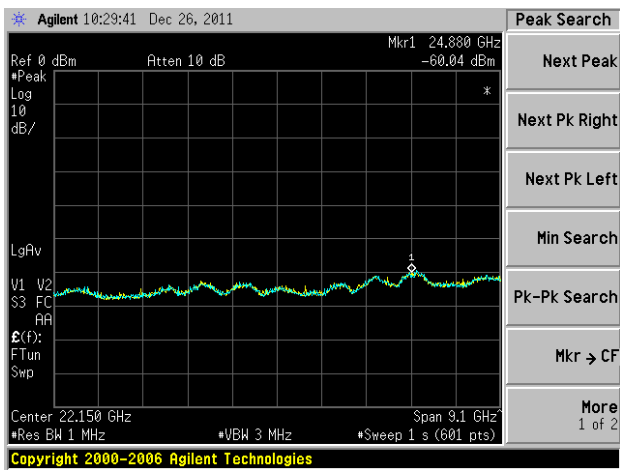

17.6GHz to 26.7GHz

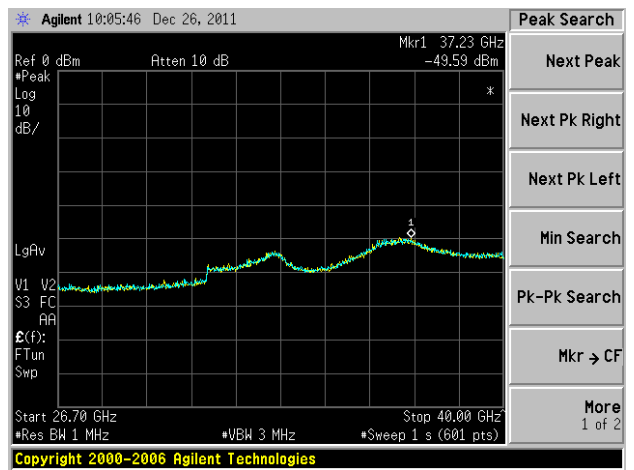

26.4GHz to 40GHz

4.4.10.3 TEST RESULTS of 0.08usec/4000Hz

Horizontally Polarized 0.08usec/4000Hz							
Range	Frequency [MHz]	level [dBm]	Pg [dBm]	Cable Loss [dB]	Antenna Gain [dB]	Pd [dBm]	Radiated Spurious Emission [dBc]
10kHz - 100MHz	47.84	-85.58	-63.1	0.5	-11.48	-75.1	-140.0
100MHz - 200MHz	157.3	-89.29	-73.9	0.5	-4.32	-78.7	-143.7
200MHz - 300MHz	266.7	-81.28	-43.7	0.5	-3.45	-47.7	-112.6
300MHz - 400MHz	326.8	-87.41	-76	0.5	2.4	-74.1	-139.1
400MHz - 500MHz	469.5	-80.96	-65.4	0.5	3.1	-62.8	-127.8
500MHz - 600MHz	500.5	-87.62	-73	0.5	3.1	-70.4	-135.4
600MHz - 700MHz	617.8	-88.39	-78.7	0.5	2.7	-76.5	-141.5
700MHz - 800MHz	707	-91.89	less than the noise floor	/	/	/	less than the noise floor
800MHz - 900MHz	828.3	-91.46	less than the noise floor	/	/	/	less than the noise floor
900MHz - 1.0GHz	955.5	-91.72	less than the noise floor	/	/	/	less than the noise floor
1.0GHz - 2.9GHz	1386	-64.42	less than the noise floor	/	/	/	less than the noise floor
2.9GHz - 6.4GHz	2929	-68.06	less than the noise floor	/	/	/	less than the noise floor
6.4GHz - 12.5GHz	9409	-16.16	less than the noise floor	/	/	/	less than the noise floor
11.9G - 18GHz	15133	-62.98	less than the noise floor	/	/	/	less than the noise floor
17.6G - 26.7GHz	18813	-48.19	-31.44	3	20	-14.4	-79.4
26.7G - 40.0GHz	28230	-44.16	-20.42	3	20	-3.4	-68.4

Vertically Polarized 0.08usec/4000Hz							
Range	Frequency [MHz]	level [dBm]	Pg [dBm]	Cable Loss [dB]	Antenna Gain [dB]	Pd [dBm]	Radiated Spurious Emission [dBc]
10kHz - 100MHz	40.01	-85.92	-47.9	0.5	-15.39	-63.7	-128.7
100MHz - 200MHz	196.7	-87.72	-62.4	0.5	-3.9	-66.8	-131.7
200MHz - 300MHz	268	-78.9	-41.0	0.5	-3.45	-45.0	-109.9
300MHz - 400MHz	392.8	-87.36	-80	0.5	3.15	-77.4	-142.3
400MHz - 500MHz	400.7	-88.83	-84	0.5	3.2	-81.3	-146.3
500MHz - 600MHz	571.5	-81.83	-68.9	0.5	2.7	-66.7	-131.7
600MHz - 700MHz	622.2	-86.72	-74.9	0.5	2.5	-72.9	-137.9
700MHz - 800MHz	708	-89.82	less than the noise floor	/	/	/	less than the noise floor
800MHz - 900MHz	877.8	-91.28	less than the noise floor	/	/	/	less than the noise floor
900MHz - 1.0GHz	943.5	-91.19	less than the noise floor	/	/	/	less than the noise floor
1.0GHz - 2.9GHz	2530	-63.48	less than the noise floor	/	/	/	less than the noise floor
2.9GHz - 6.4GHz	3151	-68.12	less than the noise floor	/	/	/	less than the noise floor
6.4GHz - 12.5GHz	9409	-22.57	less than the noise floor	/	/	/	less than the noise floor
11.9G - 18GHz	15336	-62.34	less than the noise floor	/	/	/	less than the noise floor
17.6G - 26.7GHz	18813	-46.33	-29.58	3	20	-12.6	-77.5
26.7G - 40.0GHz	28230	-48.87	-25.13	3	20	-8.1	-73.1

·Horizontally Polarized

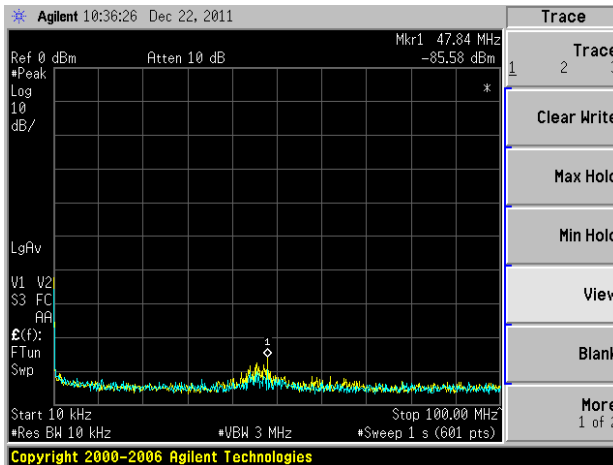

10kHz to 100MHz

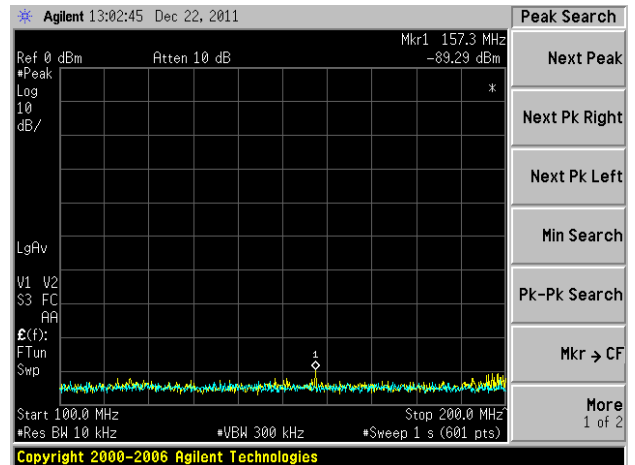

100MHz to 200MHz

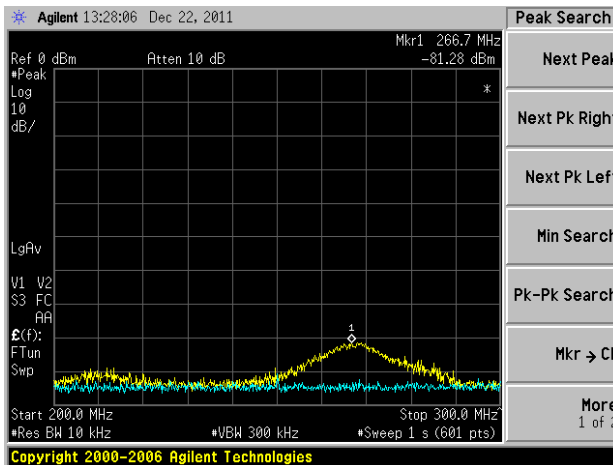

200MHz to 300MHz

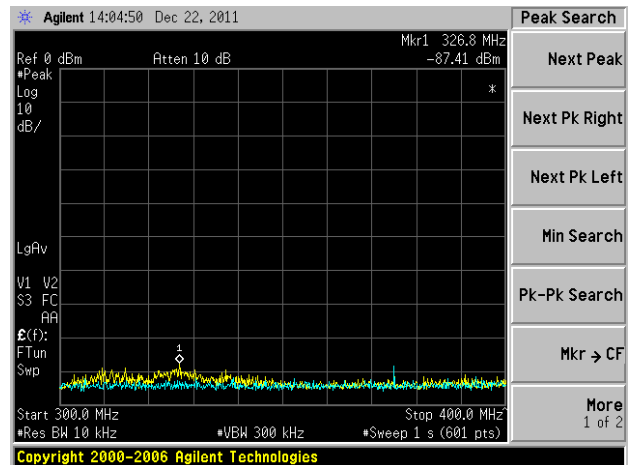

300MHz to 400MHz

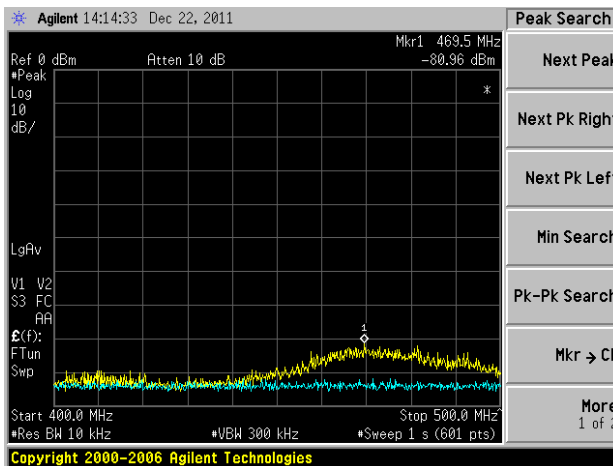

400MHz to 500MHz

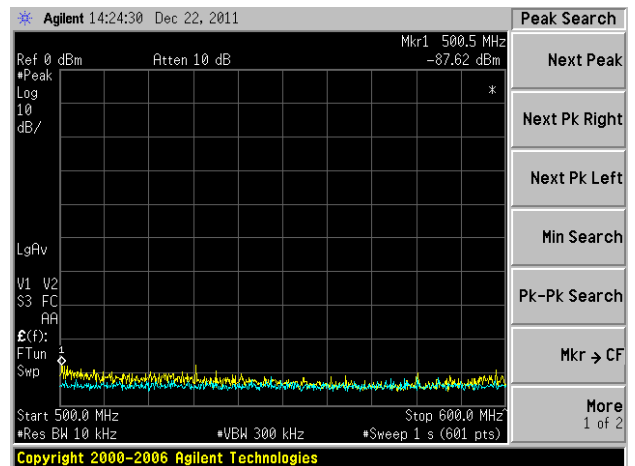

500MHz to 600MHz

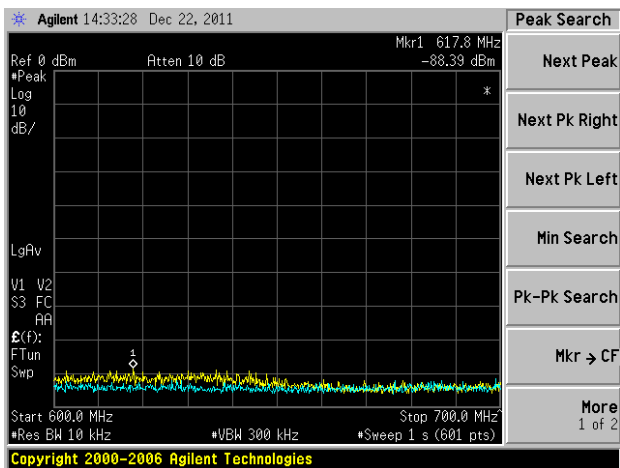

600MHz to 700MHz

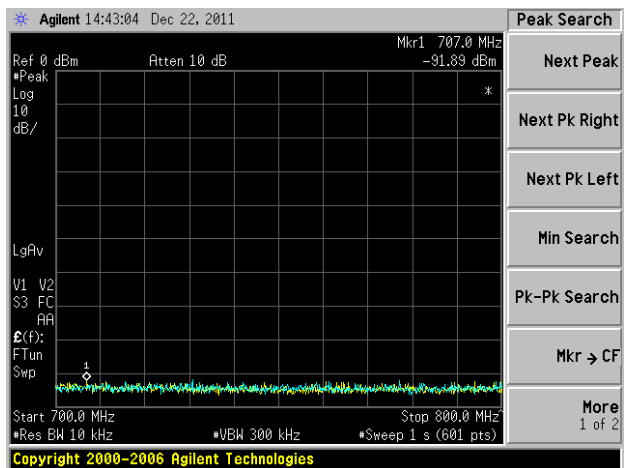

700MHz to 800MHz

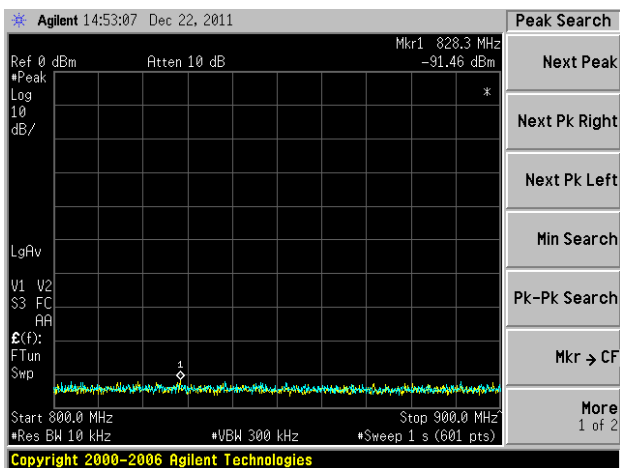

800MHz to 900MHz

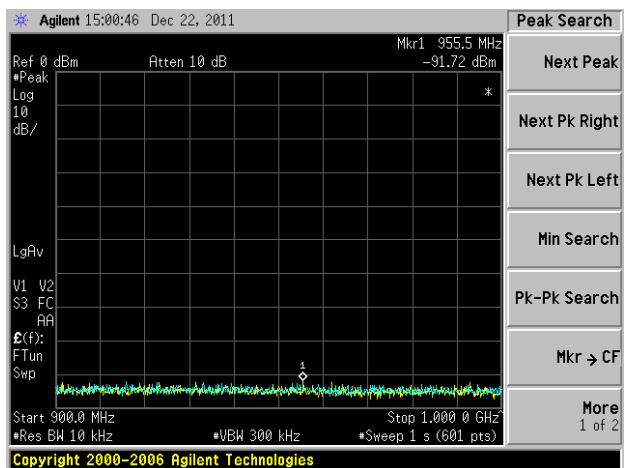

900MHz to 1GHz

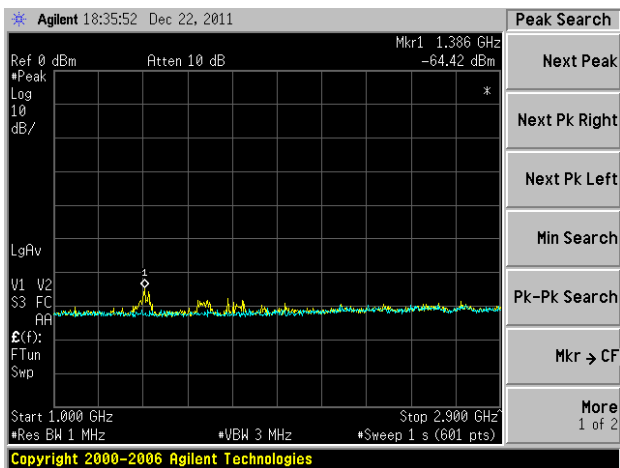

1GHz to 2.9GHz

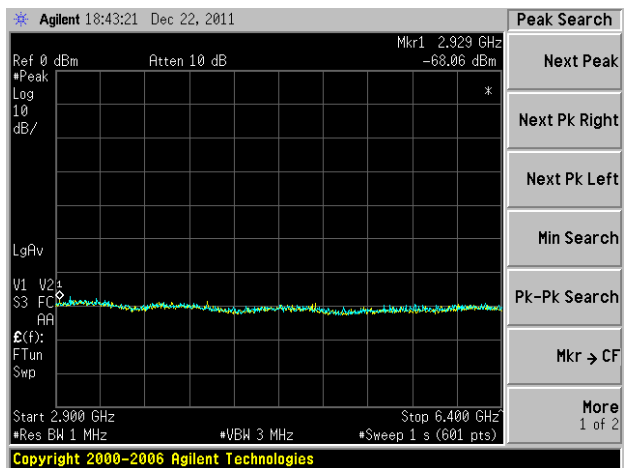

2.9GHz to 6.4GHz

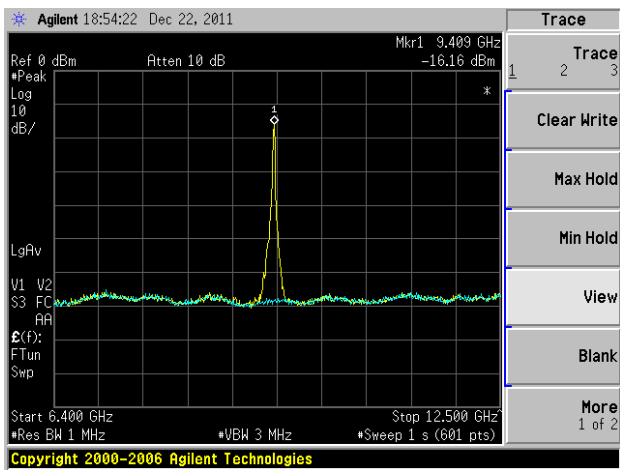

6.4GHz to 12.5GHz

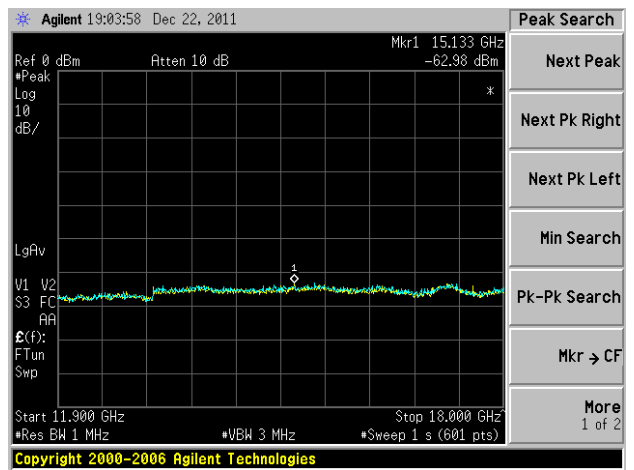

11.9GHz to 18GHz

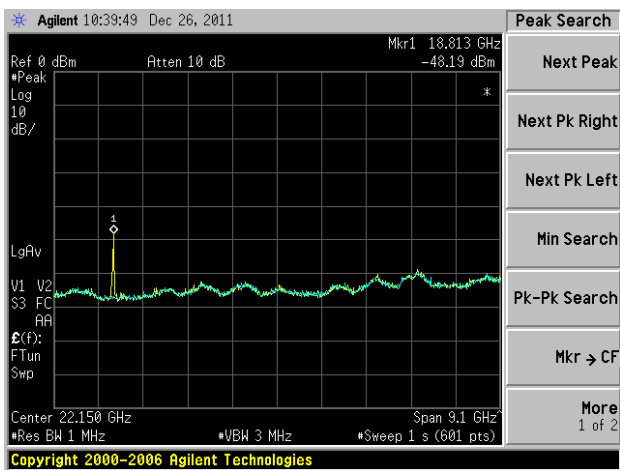

17.6GHz to 26.7GHz

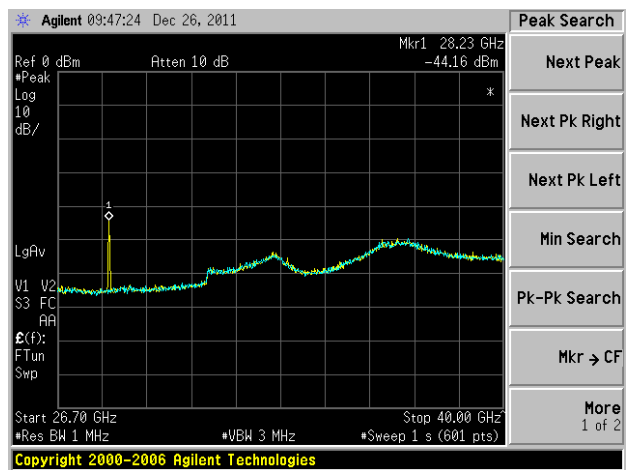

26.5GHz to 40.0GHz

·Vertically Polarized

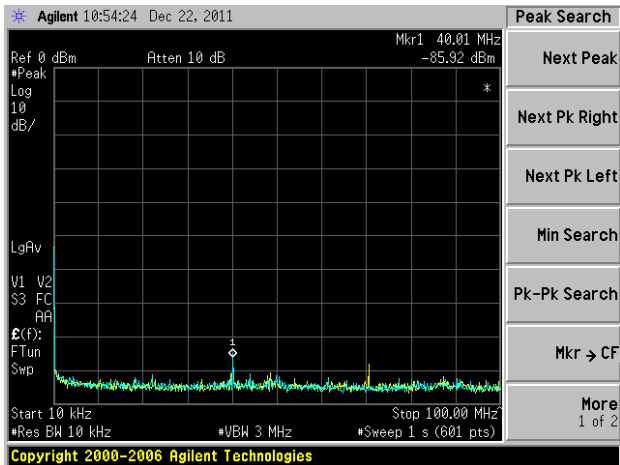

10kHz to 100MHz

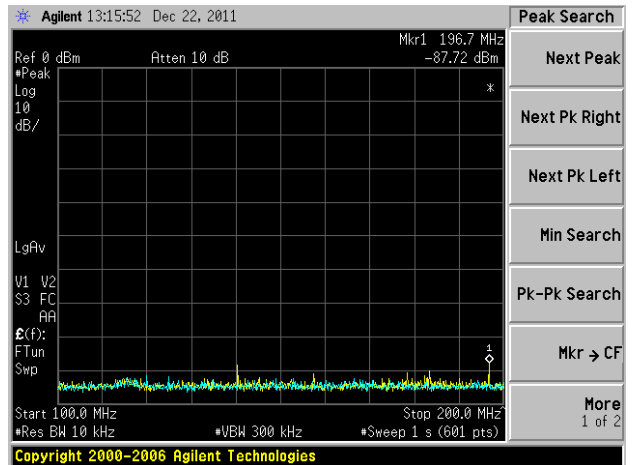

100MHz to 200MHz

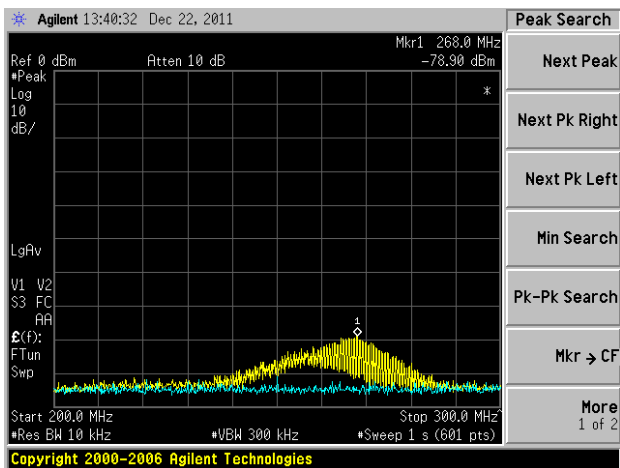

200MHz to 300MHz

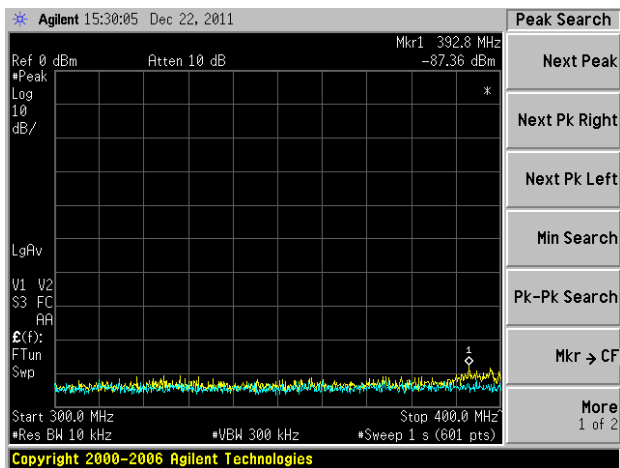

300MHz to 400MHz

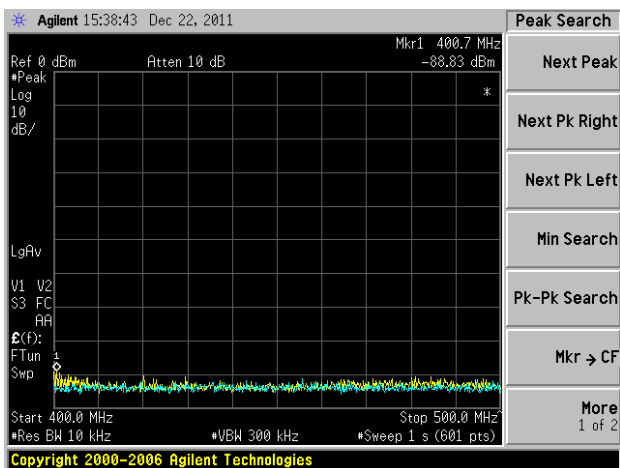

400MHz to 500MHz

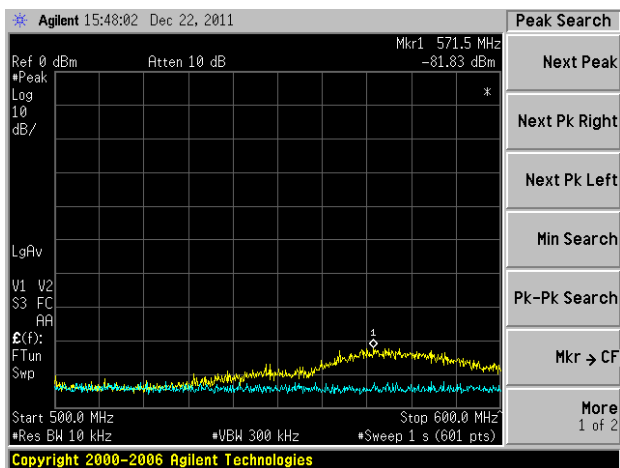

500MHz to 600MHz

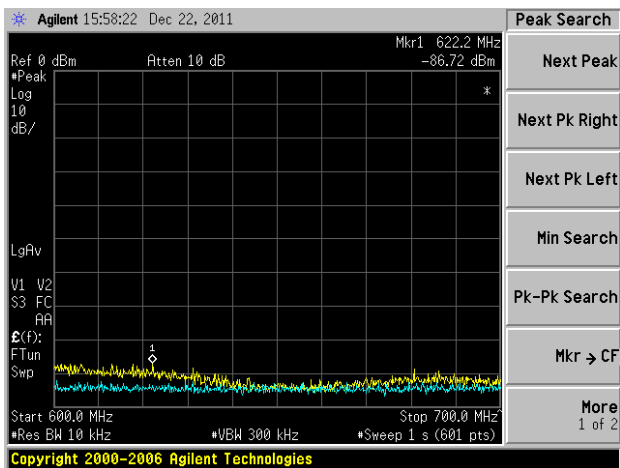

600MHz to 700MHz

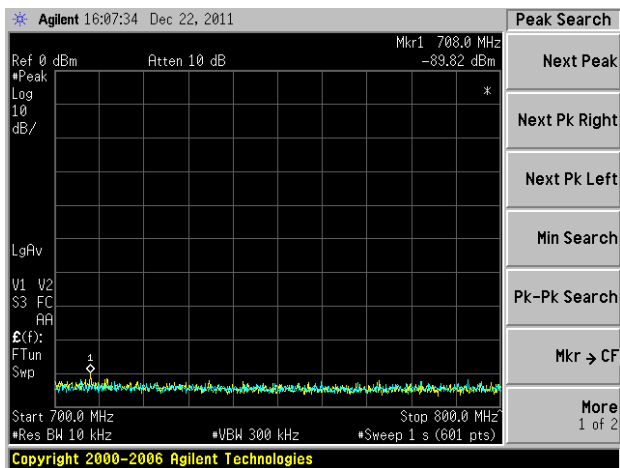

700MHz to 800MHz

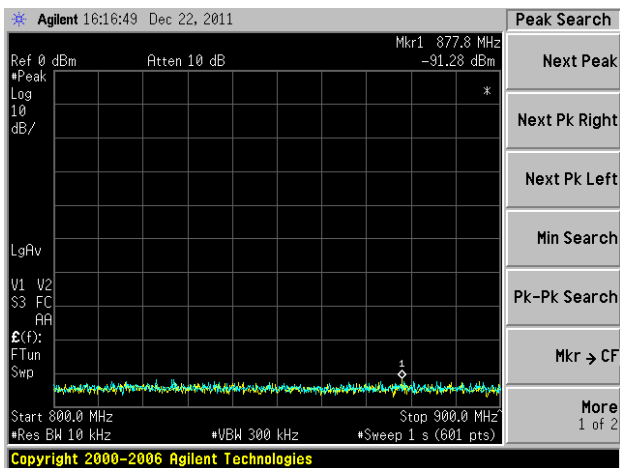

800MHz to 900MHz

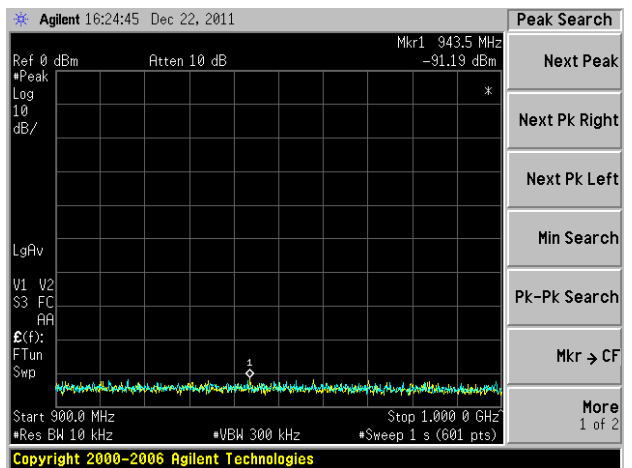

900MHz to 1GHz

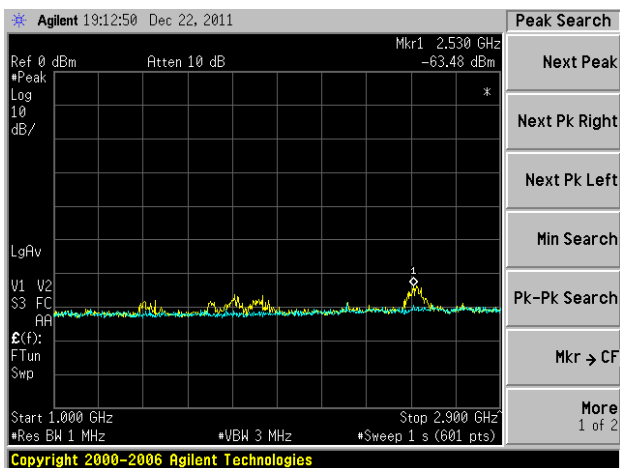

1GHz to 2.9GHz

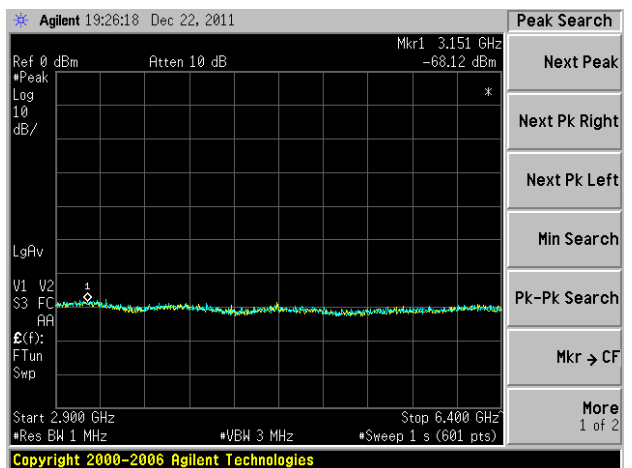

2.9GHz 6.4GHz

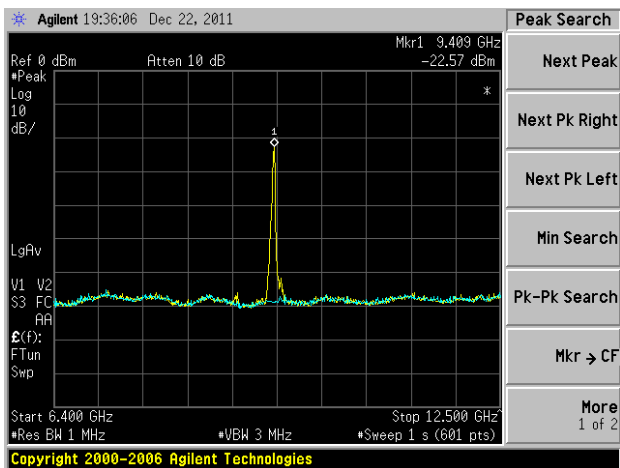

6.4GHz to 12.5GHz

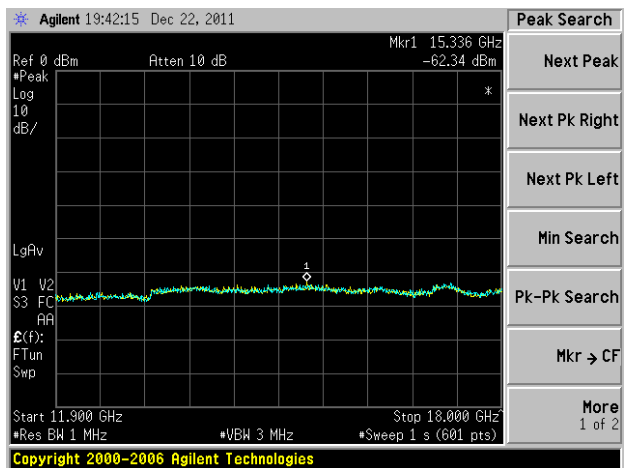

11.9GHz to 18.0GHz

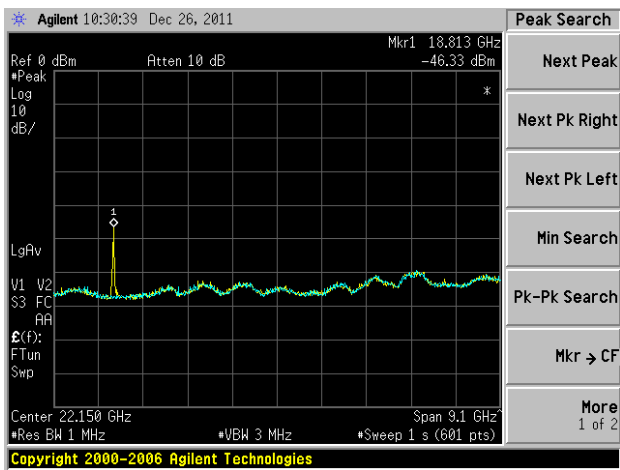

17.6GHz to 26.7GHz

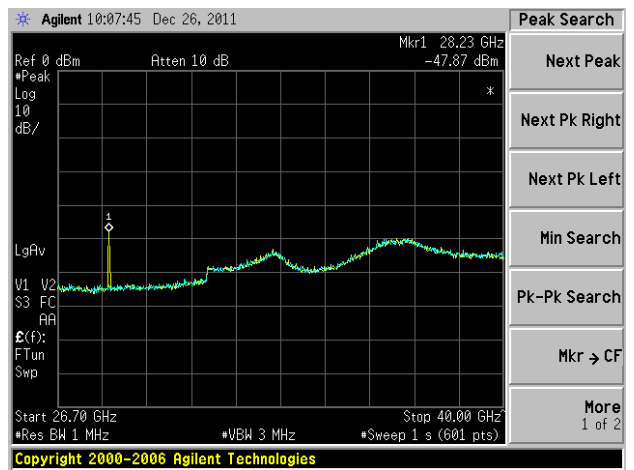

26.7GHz to 40GHz

4.4.10.4 TEST RESULTS of 0.25usec/1700Hz

Horizontally Polarized 0.08usec/2250Hz							
Range	Frequency [MHz]	level [dBm]	Pg [dBm]	Cable Loss [dB]	Antenna Gain [dB]	Pd [dBm]	Radiated Spurious Emission [dBc]
10kHz - 100MHz	47.84	-87.38	-64.9	0.5	-11.48	-76.9	-141.8
100MHz - 200MHz	157.3	-89.01	-73.6	0.5	-4.32	-78.4	-143.4
200MHz - 300MHz	269.8	-84.81	-48.0	0.5	-3.45	-52.0	-116.9
300MHz - 400MHz	315.3	-84.19	-69.5	0.5	2.1	-67.9	-132.9
400MHz - 500MHz	473.5	-81.4	-65.4	0.5	3.1	-62.8	-127.8
500MHz - 600MHz	505.3	-88.37	-74.4	0.5	3.1	-71.8	-136.8
600MHz - 700MHz	633.7	-88.76	-77.2	0.5	2.4	-75.3	-140.3
700MHz - 800MHz	725	-90.84	less than the noise floor	/	/	/	less than the noise floor
800MHz - 900MHz	883.2	-91.64	less than the noise floor	/	/	/	less than the noise floor
900MHz - 1.0GHz	927.2	-91.96	less than the noise floor	/	/	/	less than the noise floor
1.0GHz - 2.9GHz	1380	-67.34	less than the noise floor	/	/	/	less than the noise floor
2.9GHz - 6.4GHz	3215	-67.81	less than the noise floor	/	/	/	less than the noise floor
6.4GHz - 12.5GHz	9409	-17.96	less than the noise floor	/	/	/	less than the noise floor
11.9G - 18GHz	15164	-63.49	less than the noise floor	/	/	/	less than the noise floor
17.6G - 26.7GHz	18813	-47.4	-30.65	3	20	-13.7	-78.6
26.7G - 40.0GHz	28230	-45.06	-21.32	3	20	-4.3	-69.3

Vertically Polarized 0.08usec/2250Hz							
Range	Frequency [MHz]	level [dBm]	Pg [dBm]	Cable Loss [dB]	Antenna Gain [dB]	Pd [dBm]	Radiated Spurious Emission [dBc]
10kHz - 100MHz	40.01	-85.01	-46.9	0.5	-15.39	-62.8	-127.8
100MHz - 200MHz	196.7	-86.95	-61.6	0.5	-3.9	-66.0	-131.0
200MHz - 300MHz	266.2	-82.03	-45.0	0.5	-3.45	-49.0	-113.9
300MHz - 400MHz	394	-88.31	-83	0.5	3.15	-80.4	-145.3
400MHz - 500MHz	482.8	-90.39	-81	0.5	3.05	-78.45	-143.4
500MHz - 600MHz	572.5	-82.02	-69.3	0.5	2.7	-67.1	-132.1
600MHz - 700MHz	612.2	-86.74	-75.3	0.5	2.55	-73.25	-138.2
700MHz - 800MHz	772.3	-91.36	less than the noise floor	/	/	/	less than the noise floor
800MHz - 900MHz	823.7	-91.11	less than the noise floor	/	/	/	less than the noise floor
900MHz - 1.0GHz	955.3	-91.49	less than the noise floor	/	/	/	less than the noise floor
1.0GHz - 2.9GHz	2520	-64.28	less than the noise floor	/	/	/	less than the noise floor
2.9GHz - 6.4GHz	3168	-68.18	less than the noise floor	/	/	/	less than the noise floor
6.4GHz - 12.5GHz	9409	-22.38	less than the noise floor	/	/	/	less than the noise floor
11.9G - 18GHz	17349	-63.41	less than the noise floor	/	/	/	less than the noise floor
17.6G - 26.7GHz	25092	-45.92	-29.17	3	20	-12.2	-77.1
26.7G - 40.0GHz	28230	-47.79	-24.05	3	20	-7.1	-72.0

·Horizontally Polarized

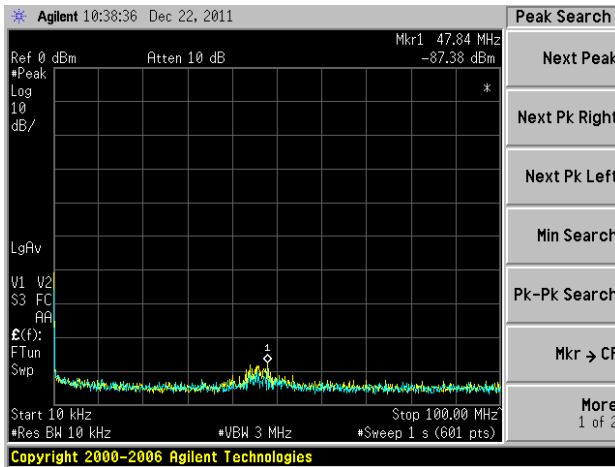

10kHz to 100MHz

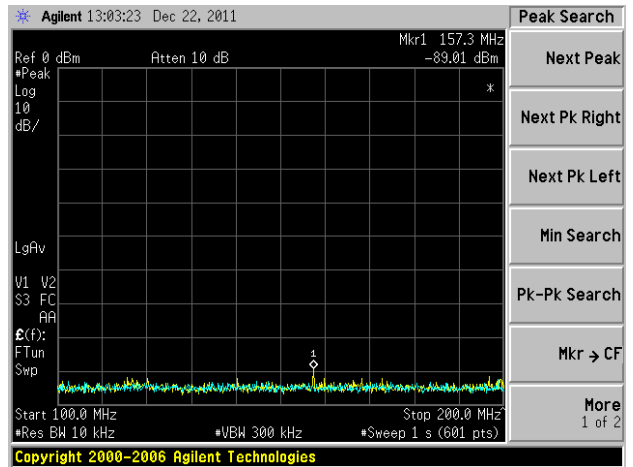

100MHz to 200MHz

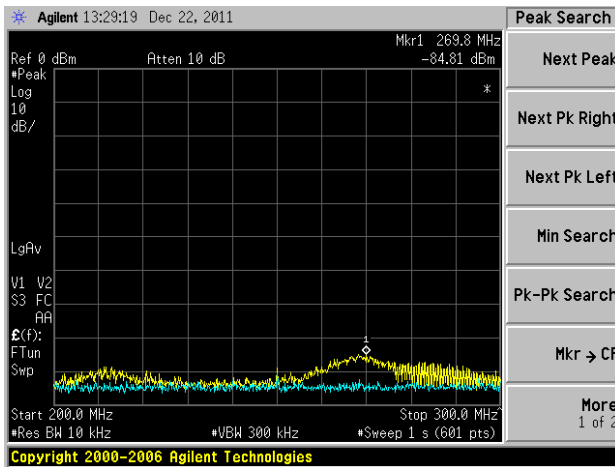

200MHz to 300MHz

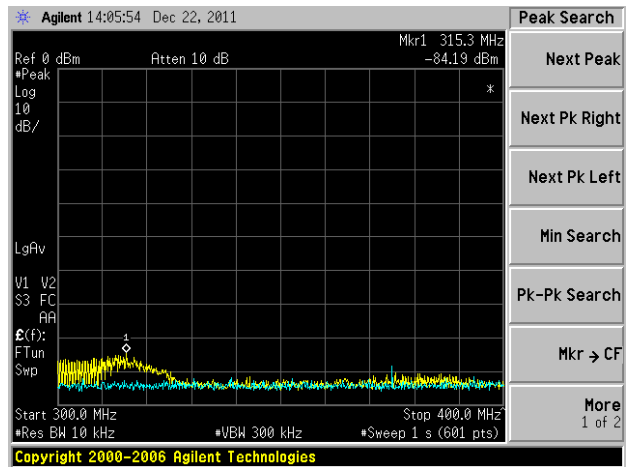

300MHz to 400MHz

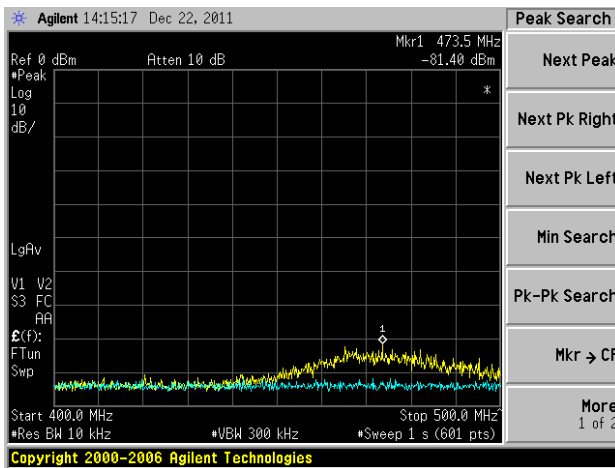

400MHz to 500MHz

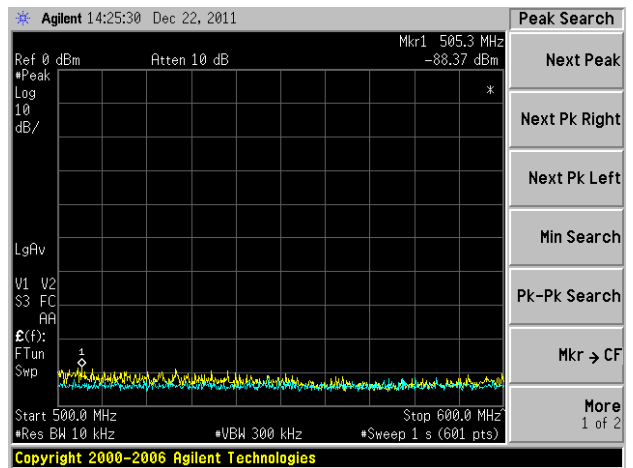

500MHz to 600MHz

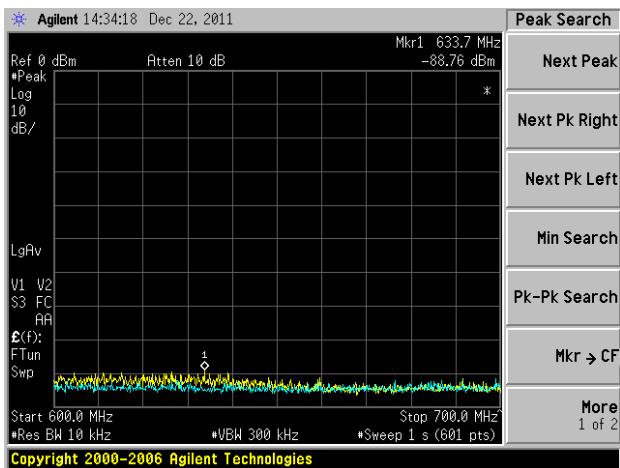

600MHz to 700MHz

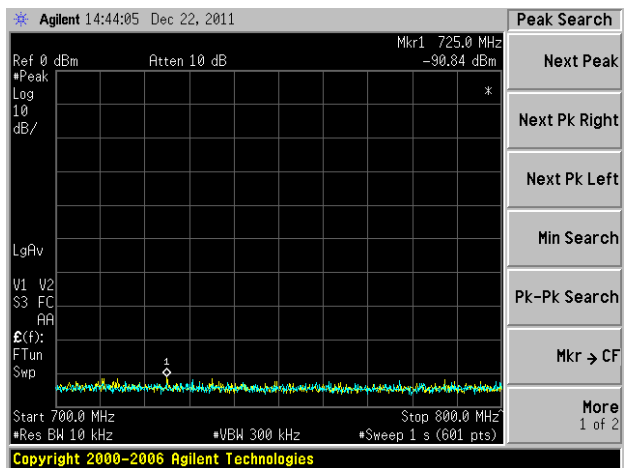

700MHz to 800MHz

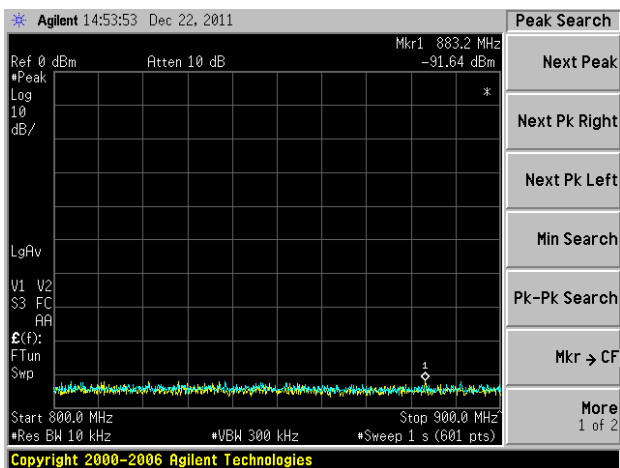

800MHz to 900MHz

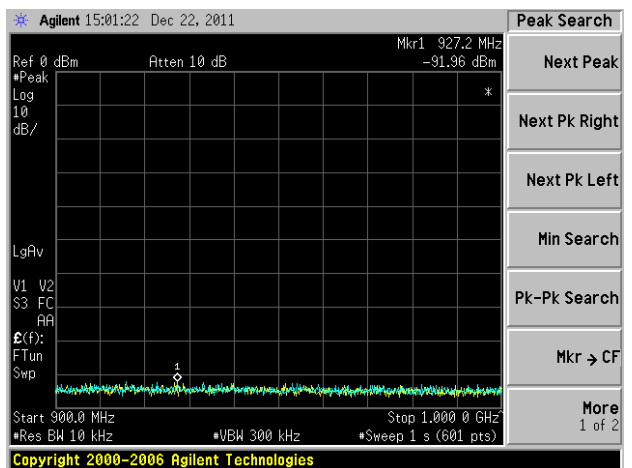

900MHz to 1GHz

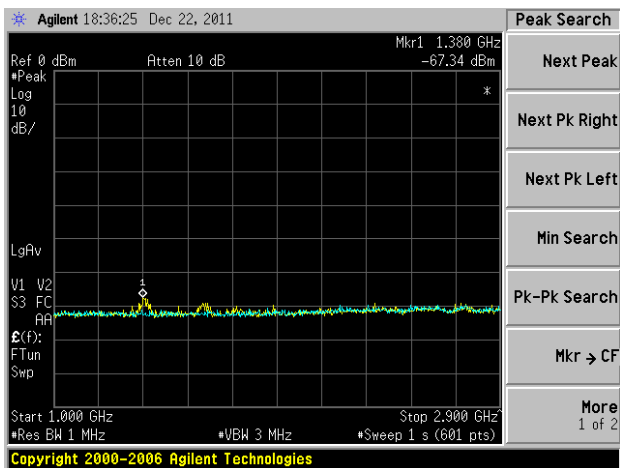

1GHz to 2.9GHz

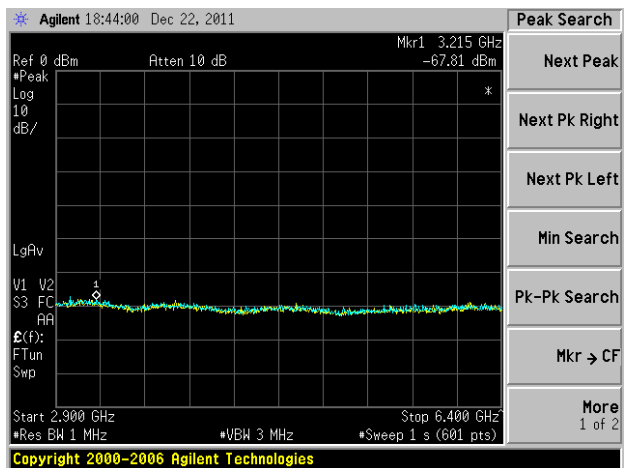

2.9GHz to 6.4GHz

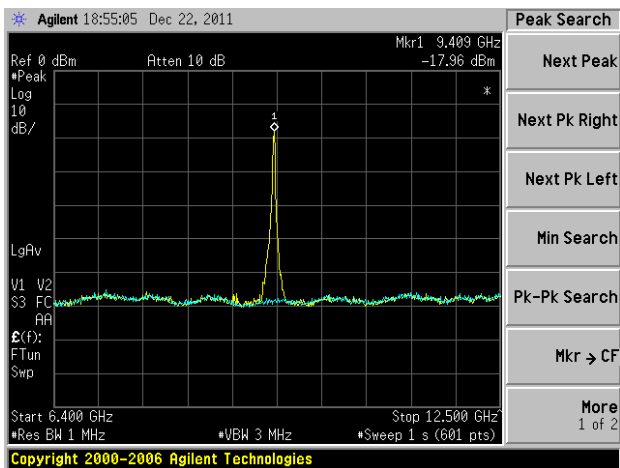

6.4GHz to 12.5GHz

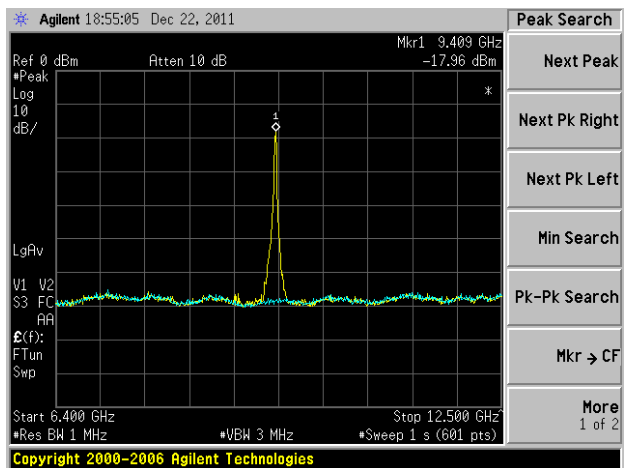

11.9GHz to 18GHz

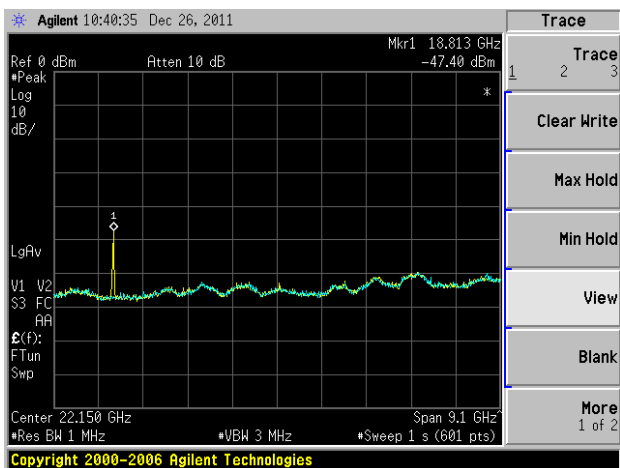

17.6GHz to 26.7GHz

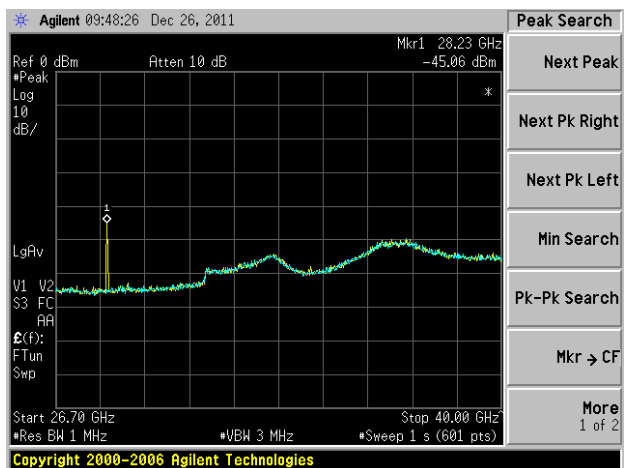

26.5GHz to 40.0GHz

·Vertically Polarized

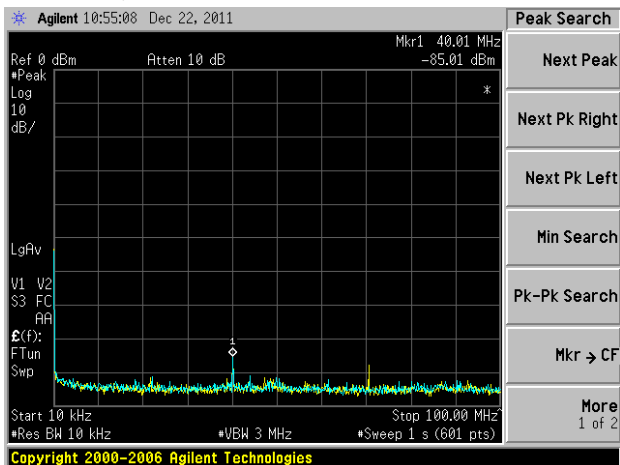

10kHz to 100MHz

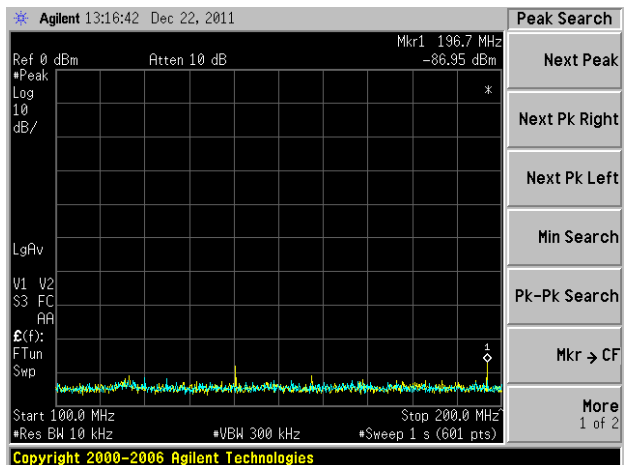

100MHz to 200MHz

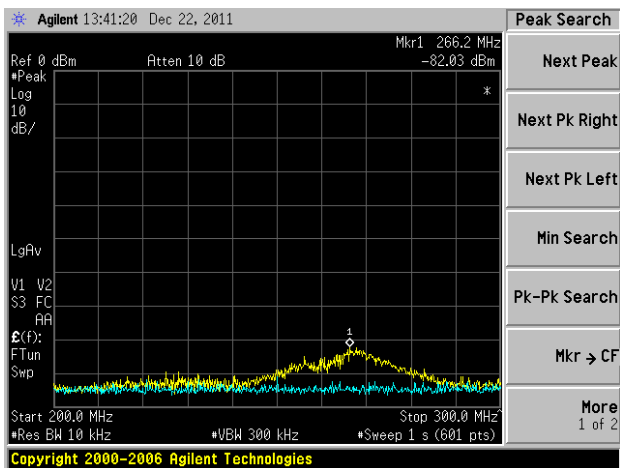

200MHz to 300MHz

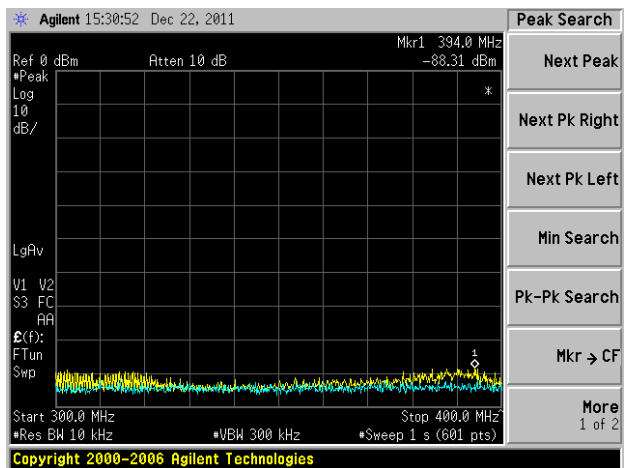

300MHz to 400MHz

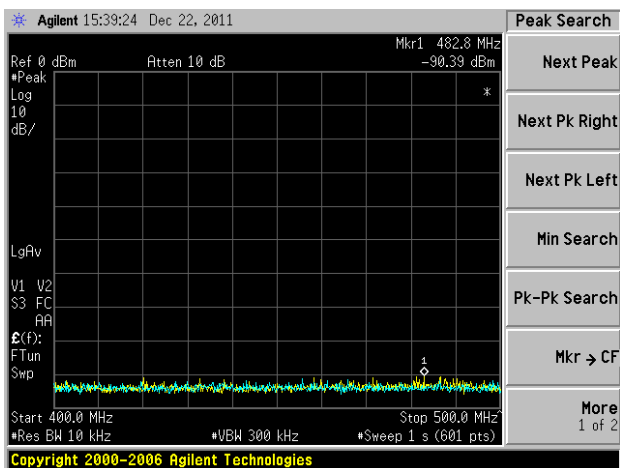

400MHz to 500MHz

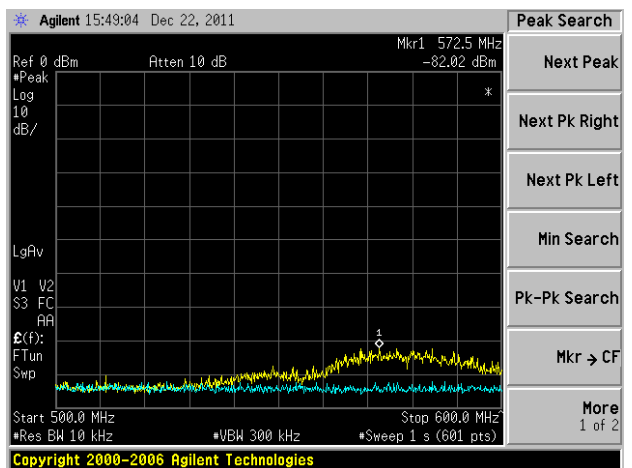

500MHz to 600MHz

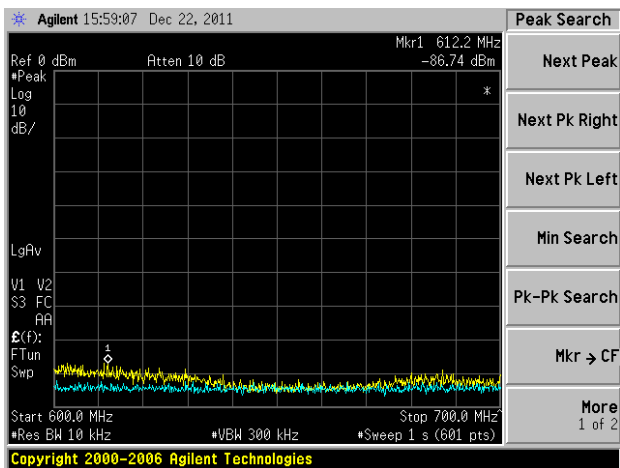

600MHz to 700MHz

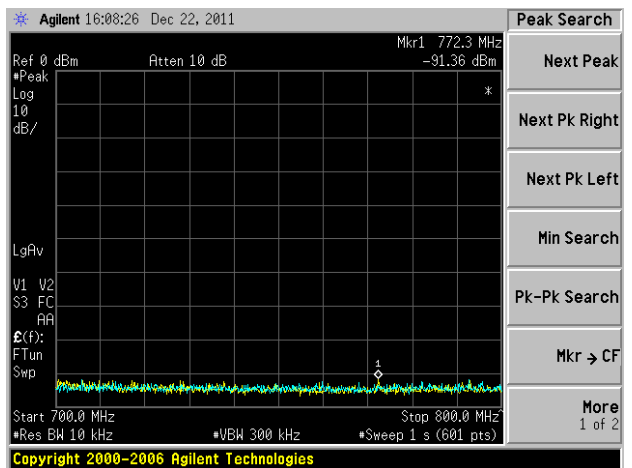

700MHz to 800MHz

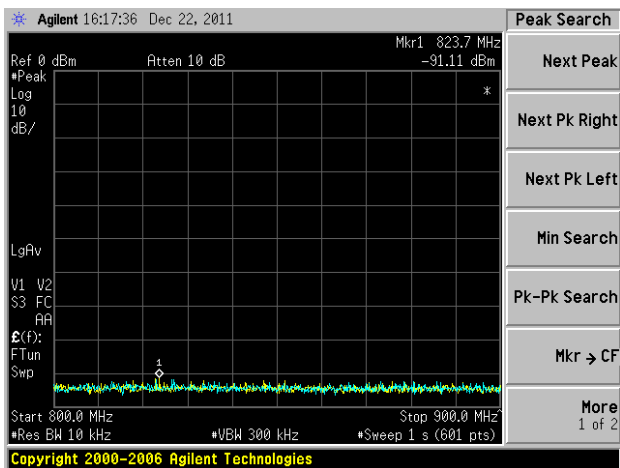

800MHz to 900MHz

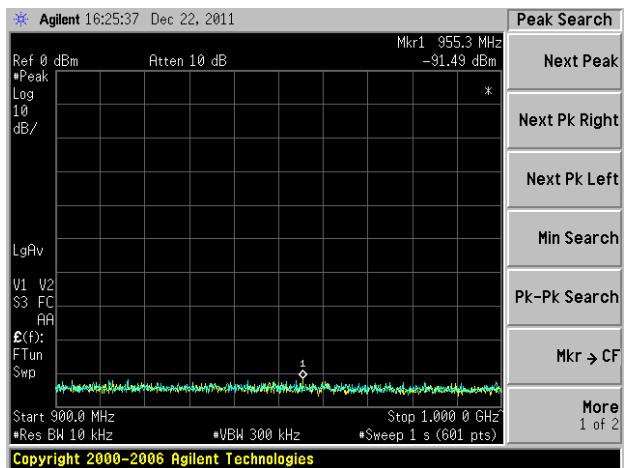

900MHz to 1GHz

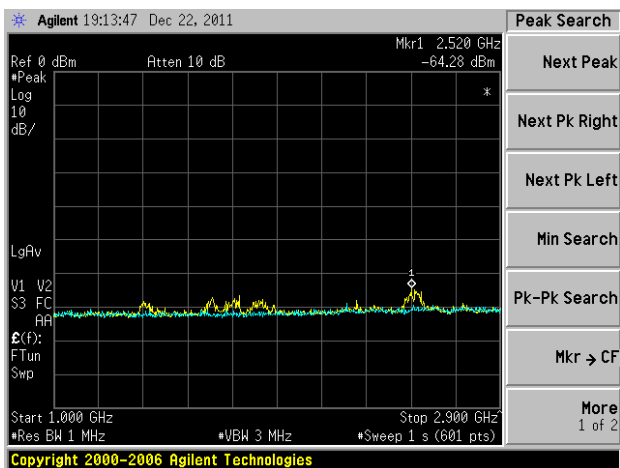

1GHz to 2.9GHz

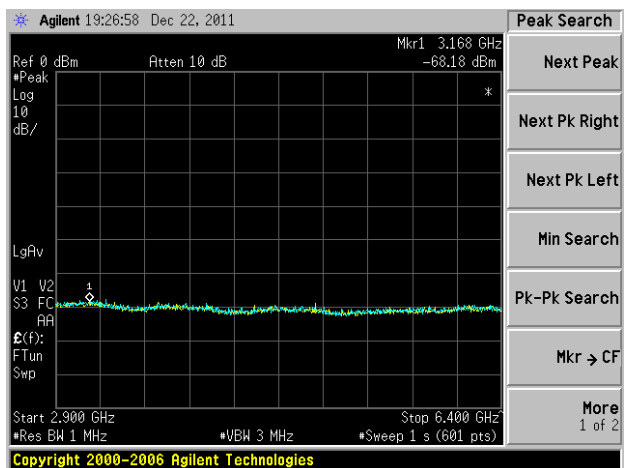

2.9GHz 6.4GHz

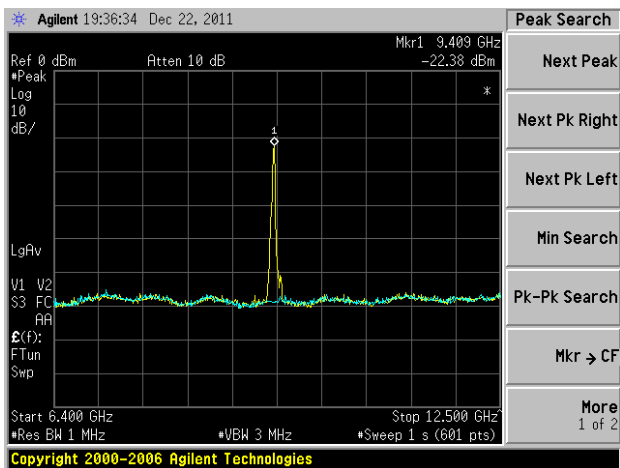

6.4GHz to 12.5GHz

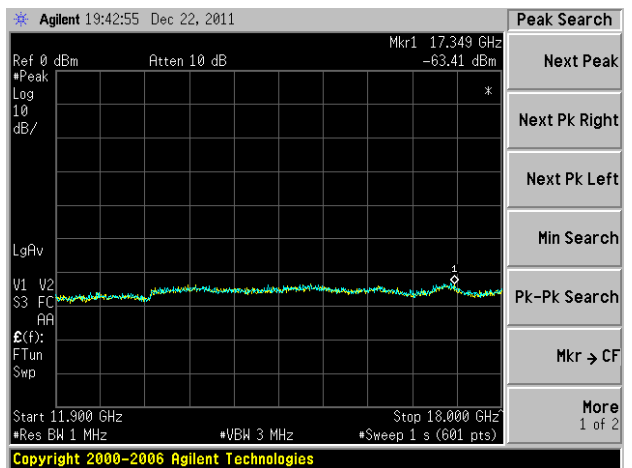

11.9GHz to 18.0GHz

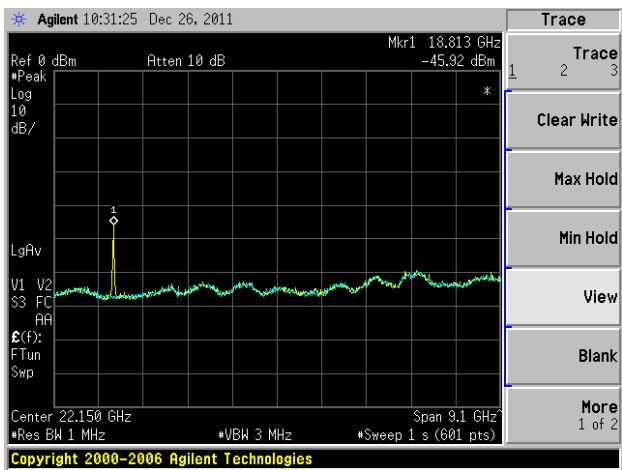

17.6GHz to 26.7GHz

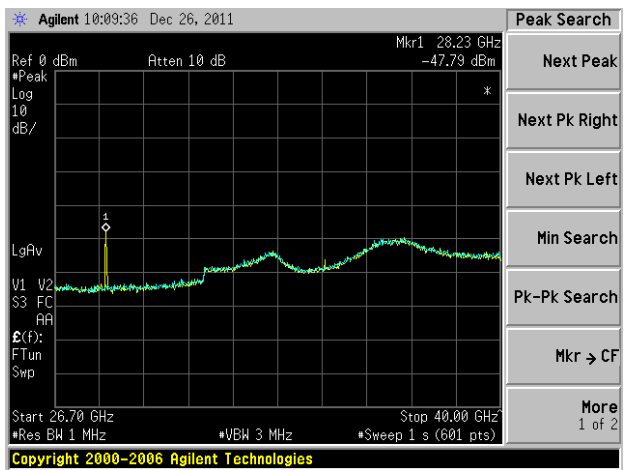

26.7GHz to 40GHz

4.4.10.5 TEST RESULTS of 0.13usec/1700Hz

Horizontally Polarized 0.13usec/1700Hz							
Range	Frequency [MHz]	level [dBm]	Pg [dBm]	Cable Loss [dB]	Antenna Gain [dB]	Pd [dBm]	Radiated Spurious Emission [dBc]
10kHz - 100MHz	47.84	-86.16	-63.7	0.5	-11.48	-75.7	-140.6
100MHz - 200MHz	157.3	-88.86	-73.5	0.5	-4.32	-78.3	-143.2
200MHz - 300MHz	265	-86.67	-52.0	0.5	-3.45	-56.0	-120.9
300MHz - 400MHz	311.7	-84.2	-68.6	0.5	2.1	-67.0	-132.0
400MHz - 500MHz	474	-78.43	-61.5	0.5	3.1	-58.9	-123.9
500MHz - 600MHz	500.8	-83.16	-65.8	0.5	3.1	-63.2	-128.2
600MHz - 700MHz	607	-89.18	-80.2	0.5	2.8	-77.9	-142.9
700MHz - 800MHz	709.2	-91.04	less than the noise floor	/	/	/	less than the noise floor
800MHz - 900MHz	868.3	-91.81	less than the noise floor	/	/	/	less than the noise floor
900MHz - 1.0GHz	993.3	-91.61	less than the noise floor	/	/	/	less than the noise floor
1.0GHz - 2.9GHz	1393	-67.44	less than the noise floor	/	/	/	less than the noise floor
2.9GHz - 6.4GHz	5373	-67.42	less than the noise floor	/	/	/	less than the noise floor
6.4GHz - 12.5GHz	9409	-14.48	less than the noise floor	/	/	/	less than the noise floor
11.9G - 18GHz	17298	-63.17	less than the noise floor	/	/	/	less than the noise floor
17.6G - 26.7GHz	18.813	-43.55	-26.8	3	20	-9.8	-74.8
26.7G - 40.0GHz	28230	-38.35	-14.61	3	20	2.4	-62.6

Vertically Polarized 0.13usec/1700Hz							
Range	Frequency [MHz]	level [dBm]	Pg [dBm]	Cable Loss [dB]	Antenna Gain [dB]	Pd [dBm]	Radiated Spurious Emission [dBc]
10kHz - 100MHz	40.01	-85.43	-47.4	0.5	-15.39	-63.3	-128.2
100MHz - 200MHz	140.3	-87.66	-69.1	0.5	-4.48	-74.0	-139.0
200MHz - 300MHz	255.8	-81.95	-47.2	0.5	-3.45	-51.2	-116.1
300MHz - 400MHz	394.7	-87.36	-80.5	0.5	3.15	-77.9	-142.8
400MHz - 500MHz	491.2	-86.87	-71	0.5	3.1	-68.4	-133.4
500MHz - 600MHz	572	-79.42	-65.9	0.5	3.1	-63.3	-128.3
600MHz - 700MHz	601.3	-84.26	-72	0.5	2.6	-69.9	-134.9
700MHz - 800MHz	702.8	-90.6	less than the noise floor	/	/	/	less than the noise floor
800MHz - 900MHz	827.7	-91.62	less than the noise floor	/	/	/	less than the noise floor
900MHz - 1.0GHz	913.8	-91.36	less than the noise floor	/	/	/	less than the noise floor
1.0GHz - 2.9GHz	2590	-65.67	less than the noise floor	/	/	/	less than the noise floor
2.9GHz - 6.4GHz	3151	-66.98	less than the noise floor	/	/	/	less than the noise floor
6.4GHz - 12.5GHz	9409	-19.25	less than the noise floor	/	/	/	less than the noise floor
11.9G - 18GHz	17329	-62.96	less than the noise floor	/	/	/	less than the noise floor
17.6G - 26.7GHz	18813	-41.64	-24.89	3	20	-7.9	-72.8
26.7G - 40.0GHz	28230	-43.08	-19.34	3	20	-2.3	-67.3

·Horizontally Polarized

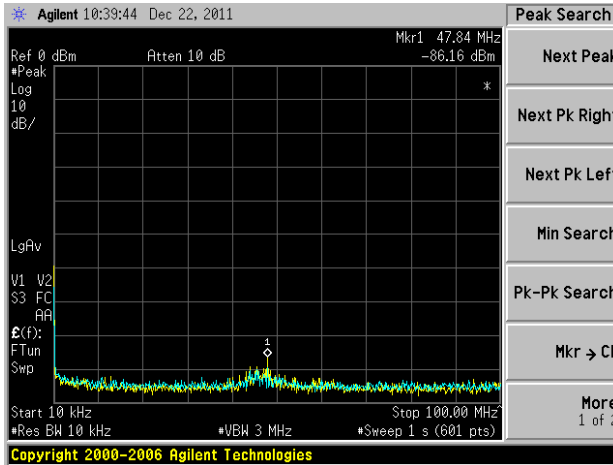

10kHz to 100MHz

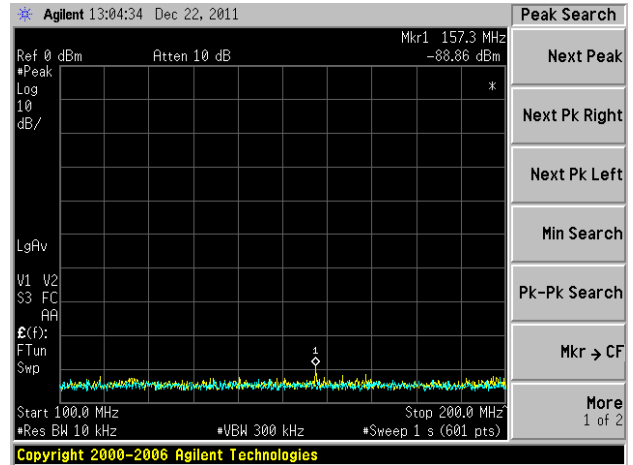

100MHz to 200MHz

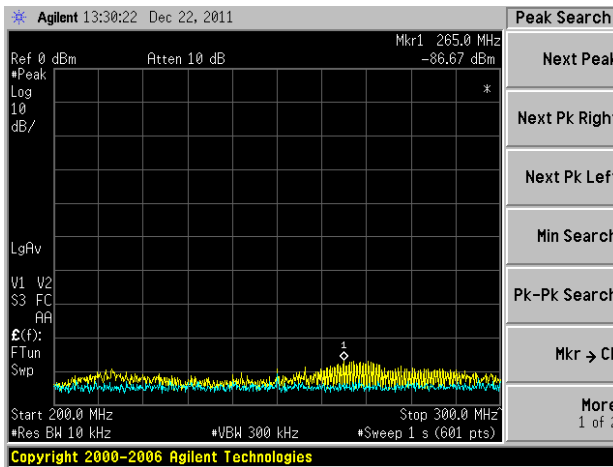

200MHz to 300MHz

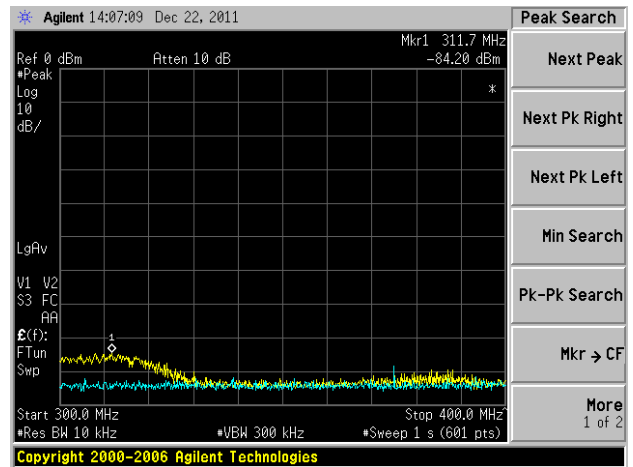

300MHz to 400MHz

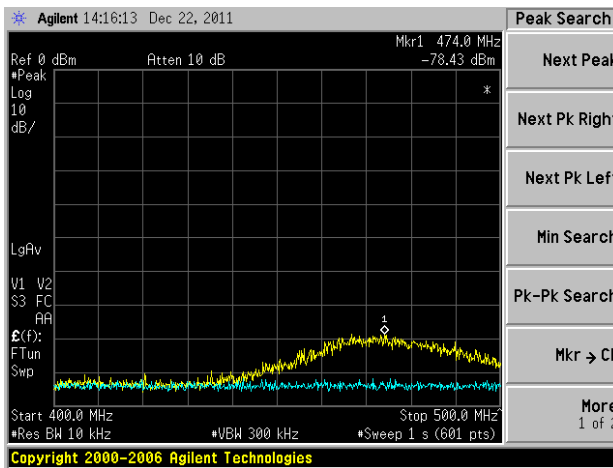

400MHz to 500MHz

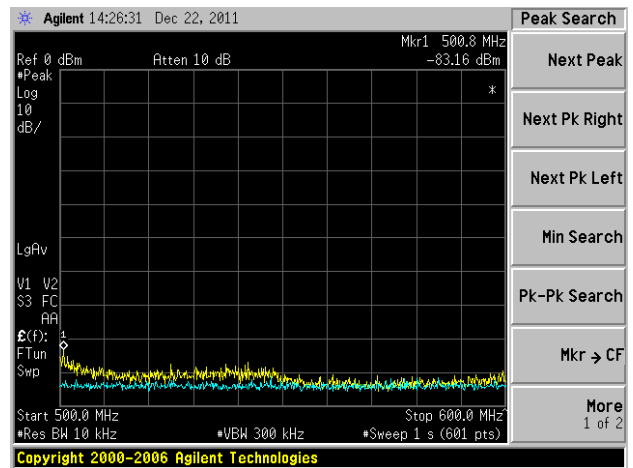

500MHz to 600MHz

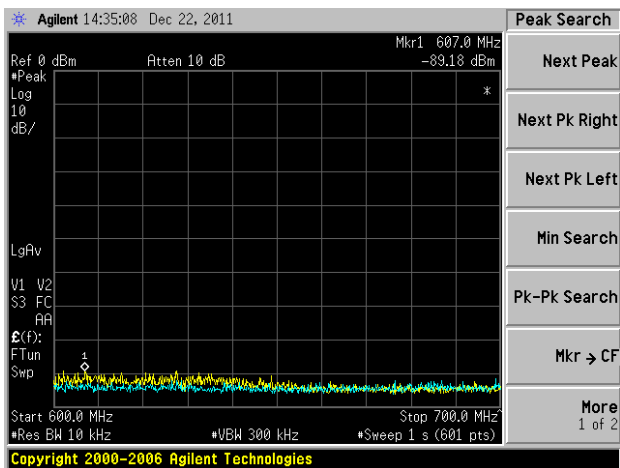

600MHz to 700MHz

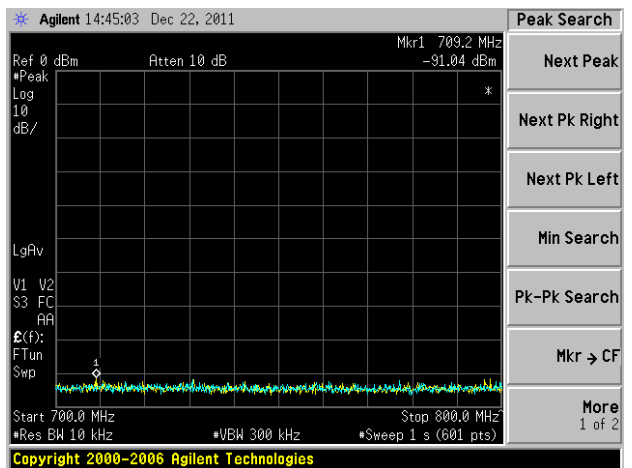

700MHz to 800MHz

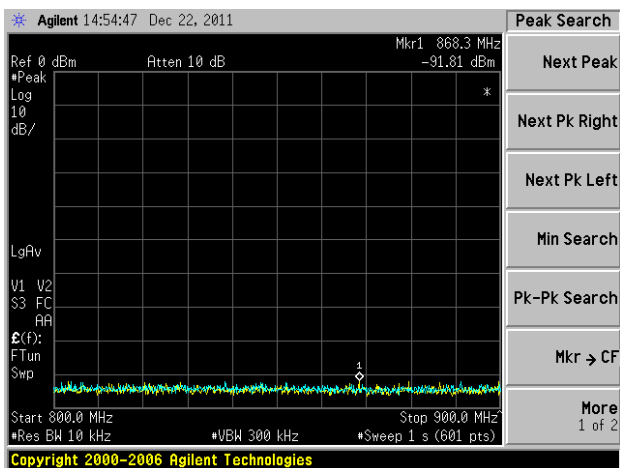

800MHz to 900MHz

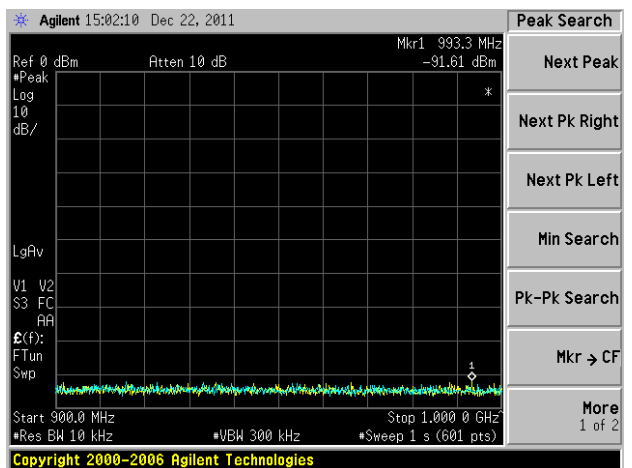

900MHz to 1GHz

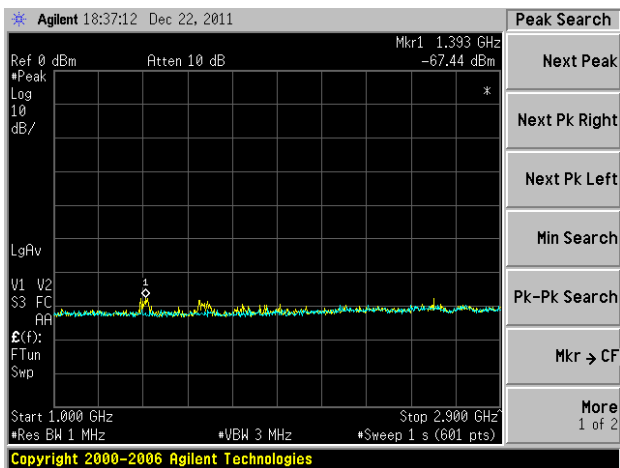

1GHz to 2.9GHz

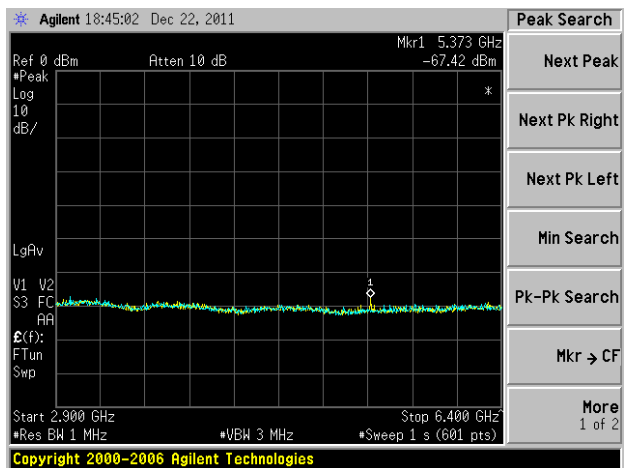

2.9GHz to 6.4GHz

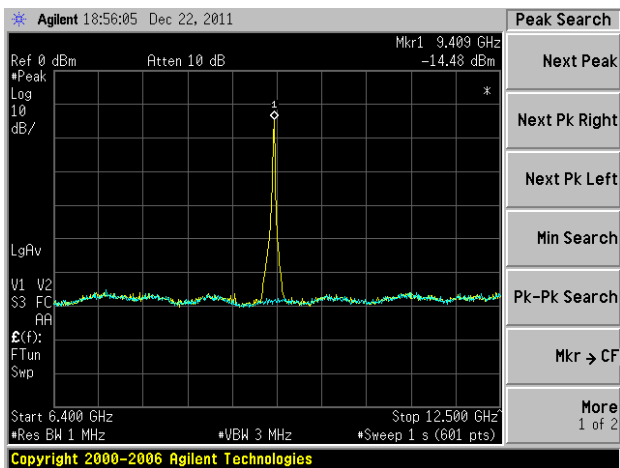

6.4GHz to 12.5GHz

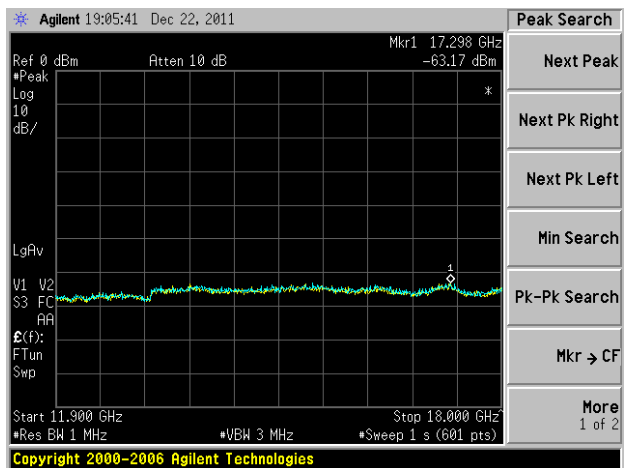

11.9GHz to 18GHz

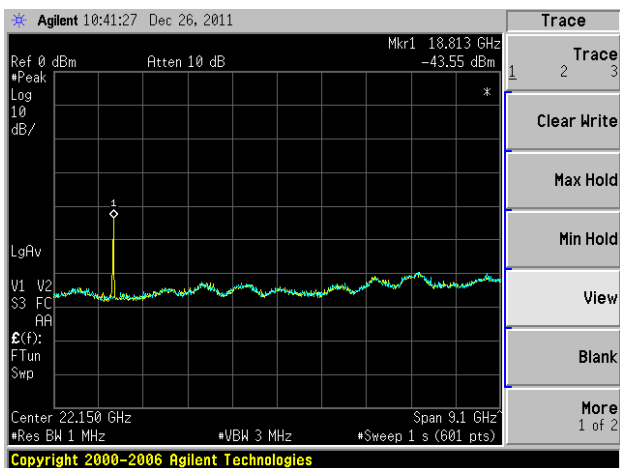

17.6GHz to 26.7GHz

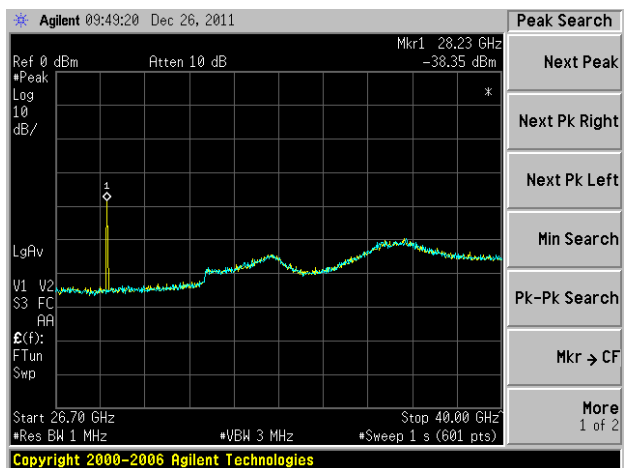

26.7GHz to 40.0GHz

·Vertically Polarized

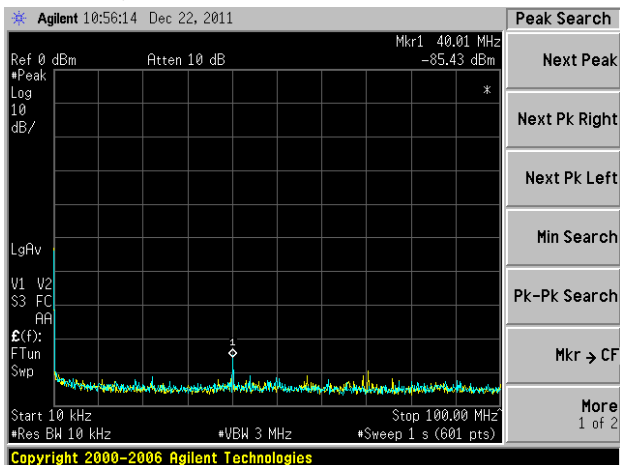

10kHz to 100MHz

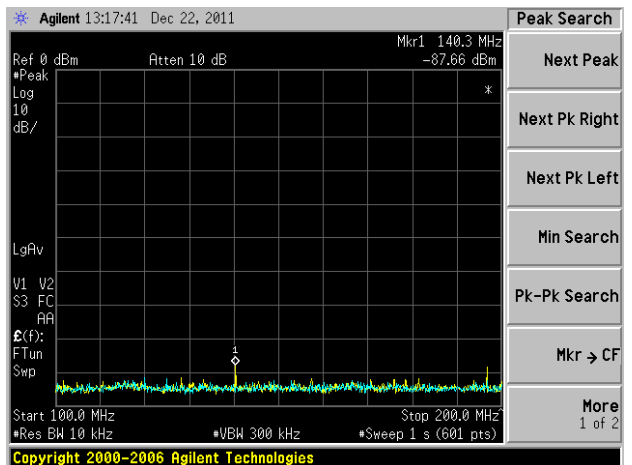

100MHz to 200MHz

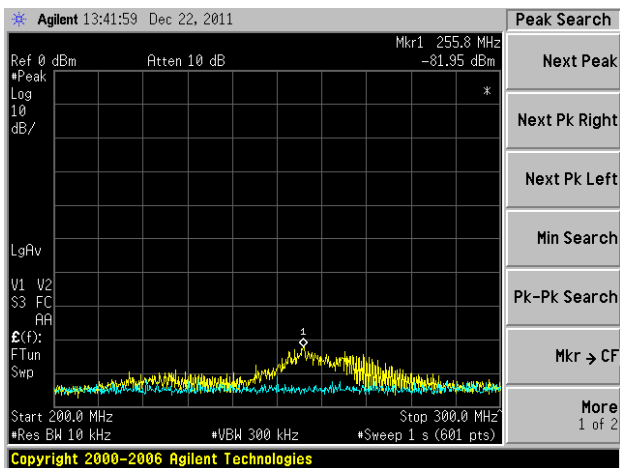

200MHz to 300MHz

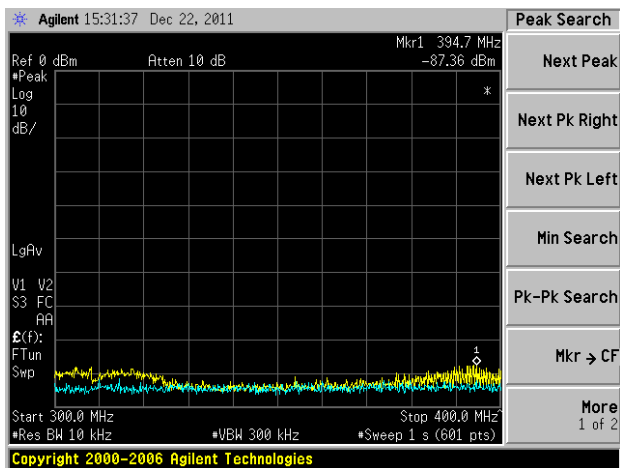

300MHz to 400MHz

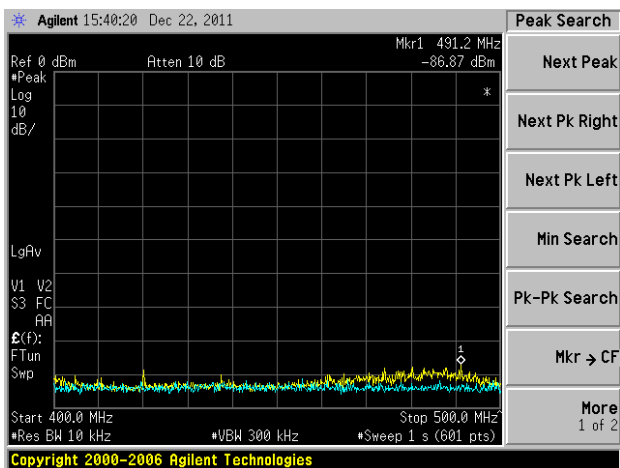

400MHz to 500MHz

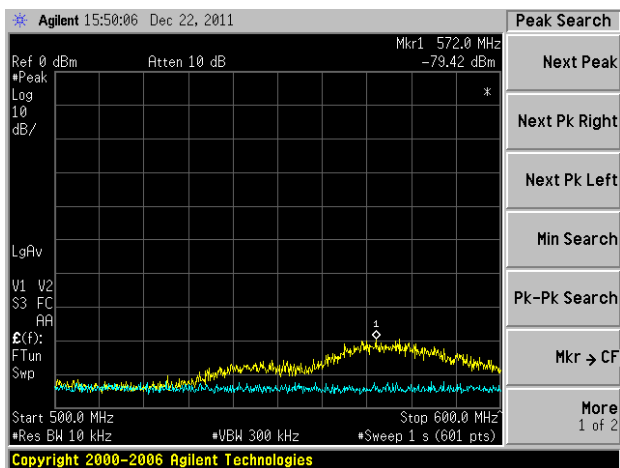

500MHz to 600MHz

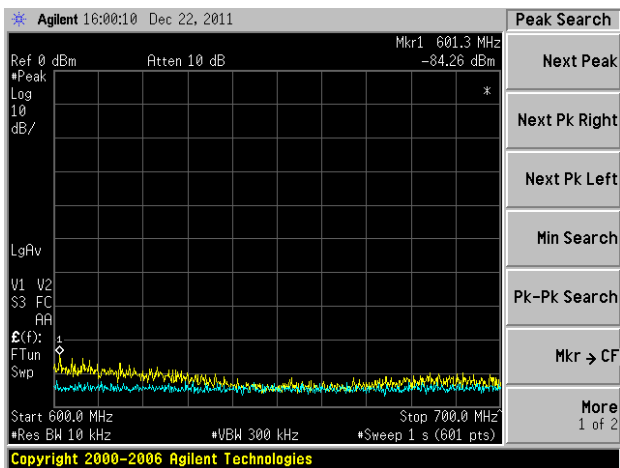

600MHz to 700MHz

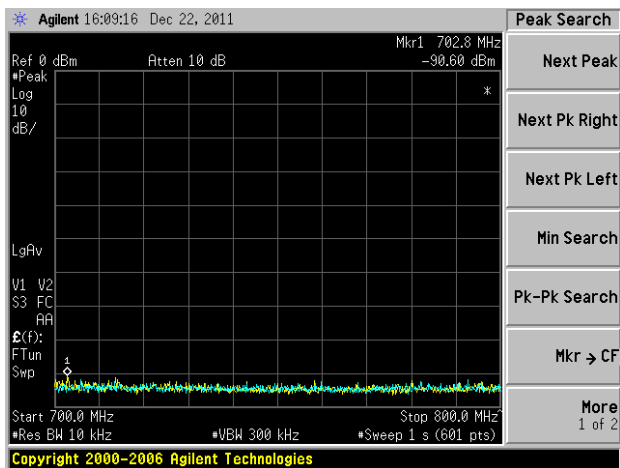

700MHz to 800MHz

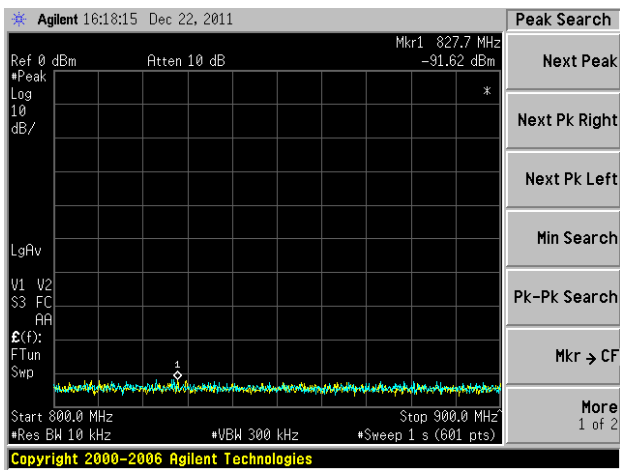

800MHz to 900MHz

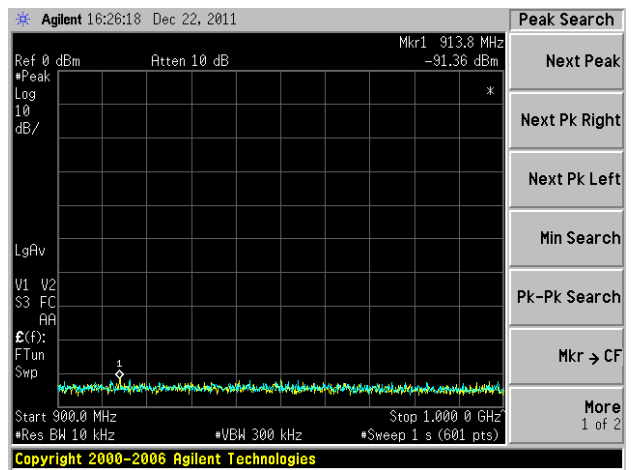

900MHz to 1GHz

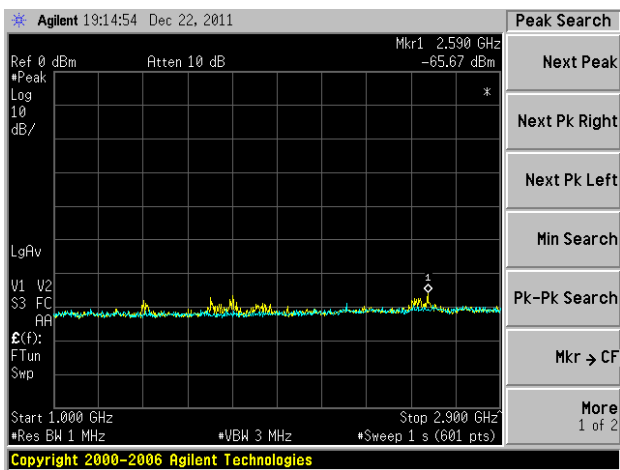

1GHz to 2.9GHz

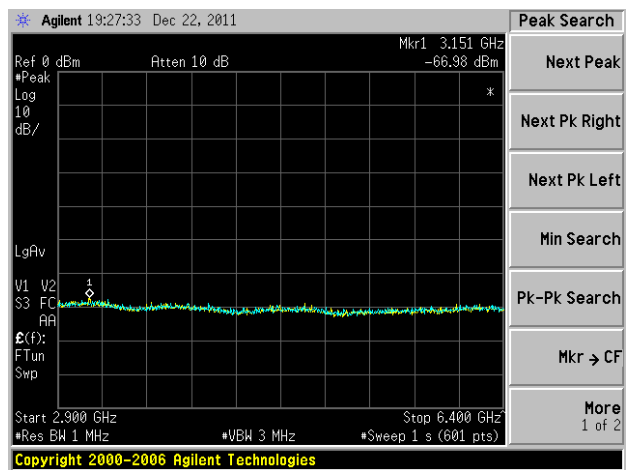

2.9GHz 6.4GHz

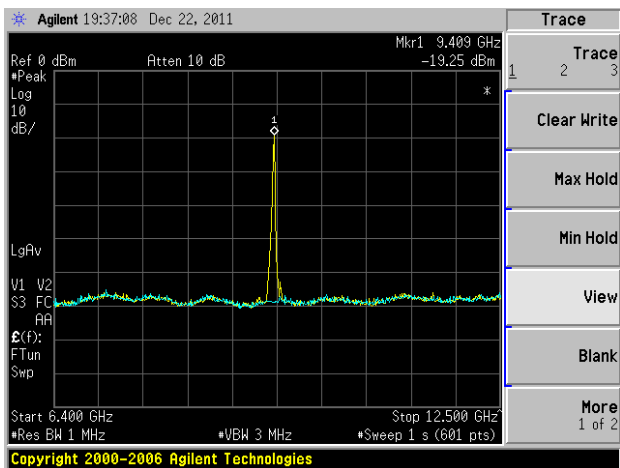

6.4GHz to 12.5GHz

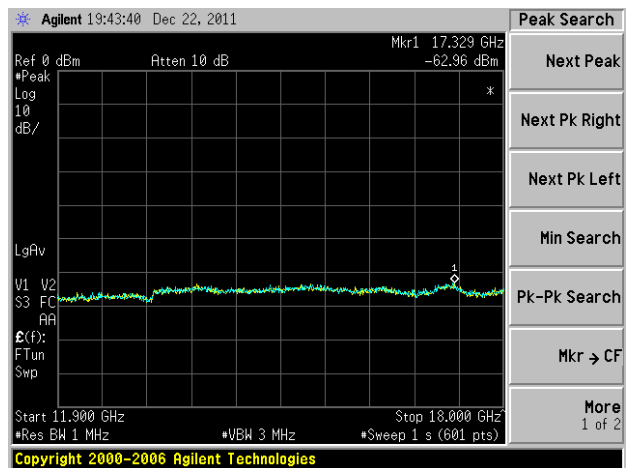

11.9GHz to 18.0GHz

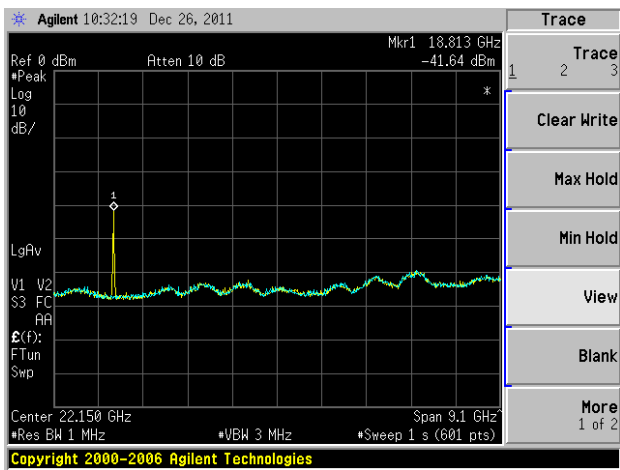

17.6GHz to 26.7GHz

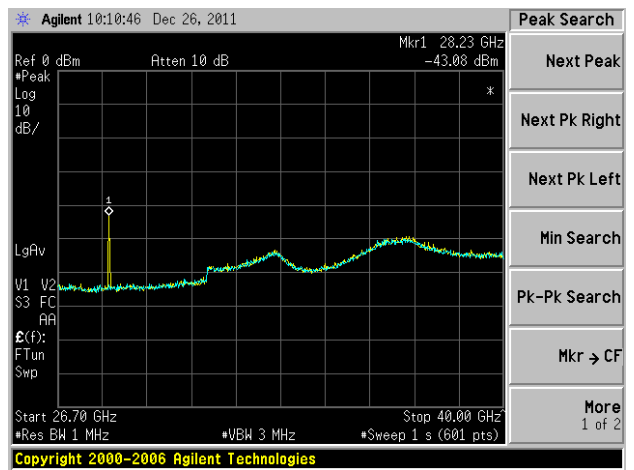

26.7GHz to 40GHz

4.4.10.6 TEST RESULTS of 0.25usec/1700Hz

Horizontally Polarized 0.25usec/1700Hz							
Range	Frequency [MHz]	level [dBm]	Pg [dBm]	Cable Loss [dB]	Antenna Gain [dB]	Pd [dBm]	Radiated Spurious Emission [dBc]
10kHz - 100MHz	47.84	-86.62	-64.2	0.5	-11.48	-76.1	-141.1
100MHz - 200MHz	157.3	-88.73	-73.3	0.5	-4.32	-78.2	-143.1
200MHz - 300MHz	269.2	-82.44	-45.0	0.5	-3.45	-49.0	-113.9
300MHz - 400MHz	300.2	-87.39	-71	0.5	2	-69.5	-134.5
400MHz - 500MHz	468.8	-78.11	-61.9	0.5	3.1	-59.3	-124.3
500MHz - 600MHz	500.5	-84.98	-67.8	0.5	3.1	-65.2	-130.2
600MHz - 700MHz	615	-88.12	-77.82	0.5	2.7	-75.62	-140.6
700MHz - 800MHz	719.2	-91.18	less than the noise floor	/	/	/	less than the noise floor
800MHz - 900MHz	844.2	-92.06	less than the noise floor	/	/	/	less than the noise floor
900MHz - 1.0GHz	929.7	-91.9	less than the noise floor	/	/	/	less than the noise floor
1.0GHz - 2.9GHz	2419	-66.21	less than the noise floor	/	/	/	less than the noise floor
2.9GHz - 6.4GHz	3262	-67.92	less than the noise floor	/	/	/	less than the noise floor
6.4GHz - 12.5GHz	9409	-11.4	less than the noise floor	/	/	/	less than the noise floor
11.9G - 18GHz	17217	-62.68	less than the noise floor	/	/	/	less than the noise floor
17.6G - 26.7GHz	18813	-38.76	-22.01	3	20	-5.0	-70.0
26.7G - 40.0GHz	28230	-33.89	-10.15	3	20	6.9	-58.1

Vertically Polarized 0.25usec/1700Hz							
Range	Frequency [MHz]	level [dBm]	Pg [dBm]	Cable Loss [dB]	Antenna Gain [dB]	Pd [dBm]	Radiated Spurious Emission [dBc]
10kHz - 100MHz	40.01	-84.83	-46.8	0.5	-15.39	-62.7	-127.6
100MHz - 200MHz	196.7	-86.46	-61.1	0.5	-3.9	-65.5	-130.5
200MHz - 300MHz	268.2	-79.84	-42.5	0.5	-3.45	-46.5	-111.4
300MHz - 400MHz	389.2	-88.74	-83	0.5	3.15	-80.4	-145.3
400MHz - 500MHz	489.3	-87.83	-72	0.5	3.1	-69.4	-134.4
500MHz - 600MHz	565.7	-80.41	-66.4	0.5	2.7	-64.2	-129.2
600MHz - 700MHz	611.7	-87.08	-76.2	0.5	2.55	-74.15	-139.1
700MHz - 800MHz	700.3	-90.12	less than the noise floor	/	/	/	less than the noise floor
800MHz - 900MHz	894.7	-92.14	less than the noise floor	/	/	/	less than the noise floor
900MHz - 1.0GHz	918.2	-91.81	less than the noise floor	/	/	/	less than the noise floor
1.0GHz - 2.9GHz	1776	-68.07	less than the noise floor	/	/	/	less than the noise floor
2.9GHz - 6.4GHz	3250	-67.42	less than the noise floor	/	/	/	less than the noise floor
6.4GHz - 12.5GHz	9409	-14.46	less than the noise floor	/	/	/	less than the noise floor
11.9G - 18GHz	17298	-62.39	less than the noise floor	/	/	/	less than the noise floor
17.6G - 26.7GHz	18813	-37.61	-20.86	3	20	-3.9	-68.8
26.7G - 40.0GHz	28230	-38.29	-14.55	3	20	2.5	-62.5

• Horizontally Polarized

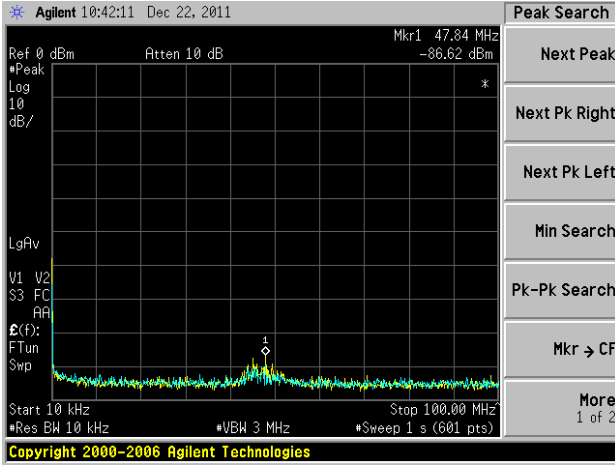

10kHz to 100MHz

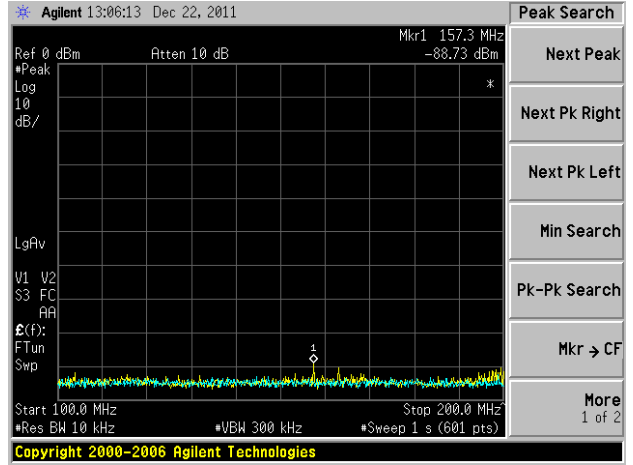

100MHz to 200MHz

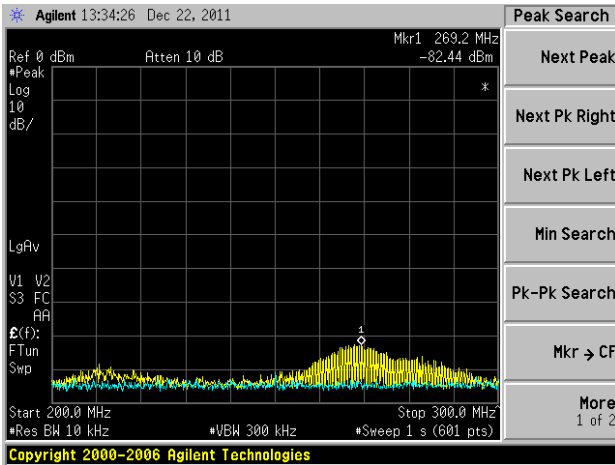

200MHz to 300MHz

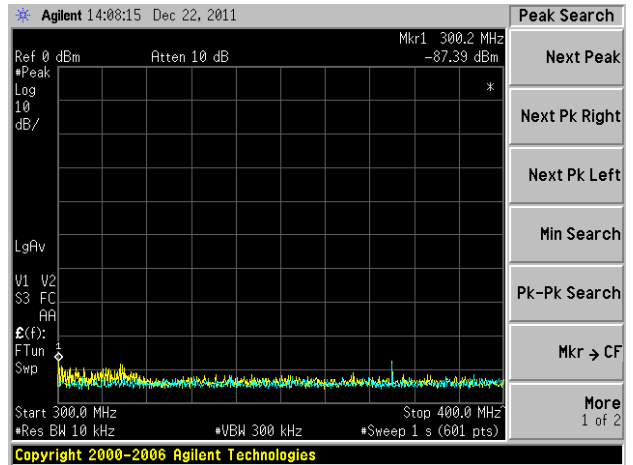

300MHz to 400MHz

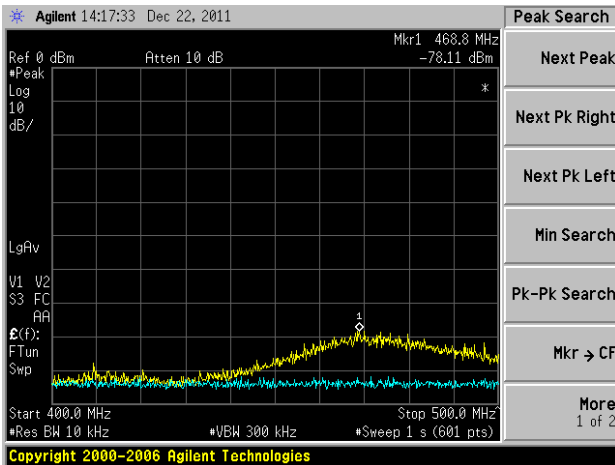

400MHz to 500MHz

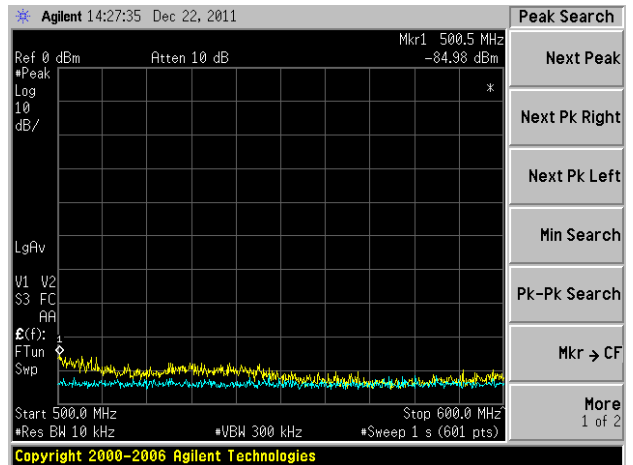

500MHz to 600MHz

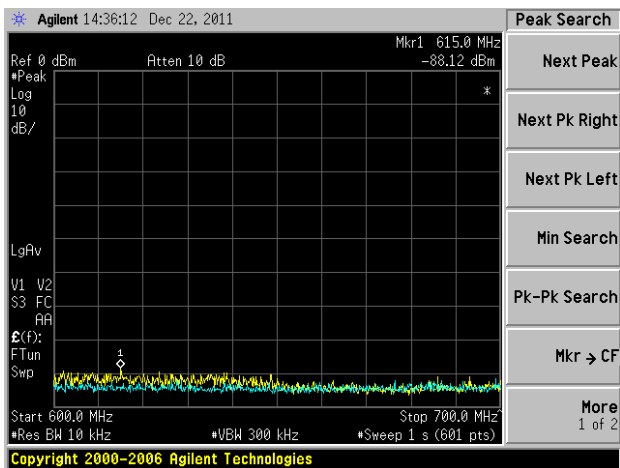

600MHz to 700MHz

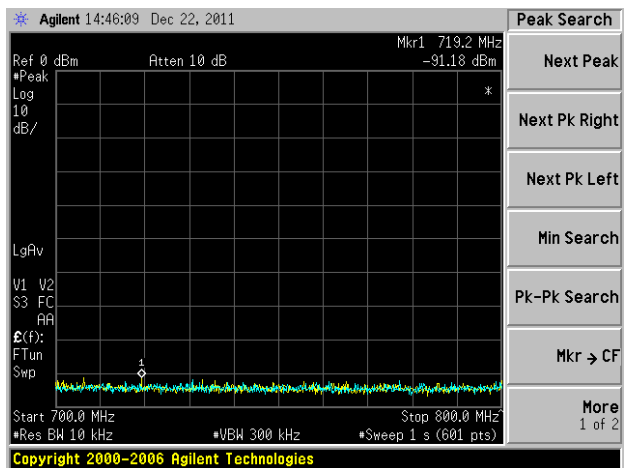

700MHz to 800MHz

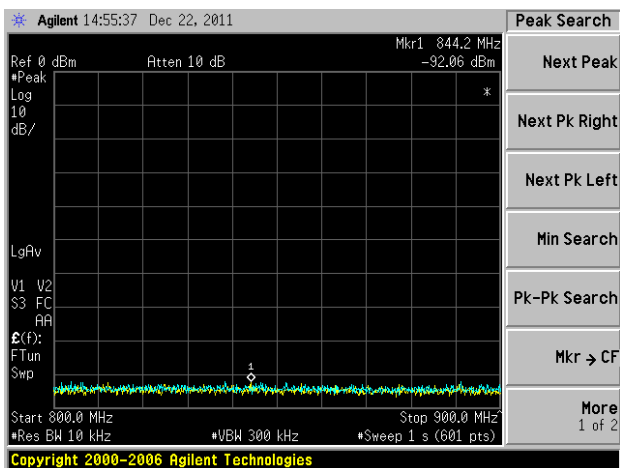

800MHz to 900MHz

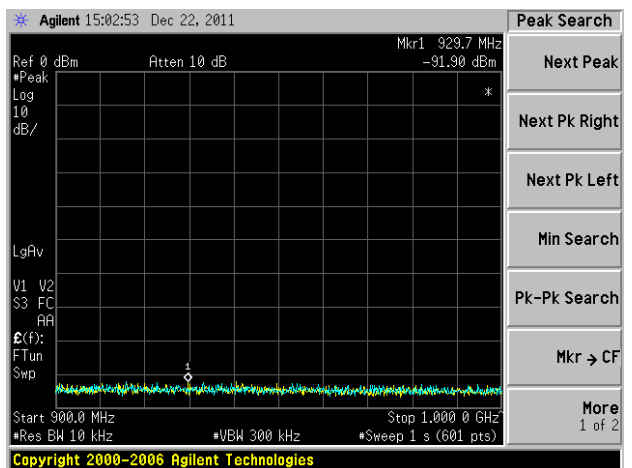

900MHz to 1GHz

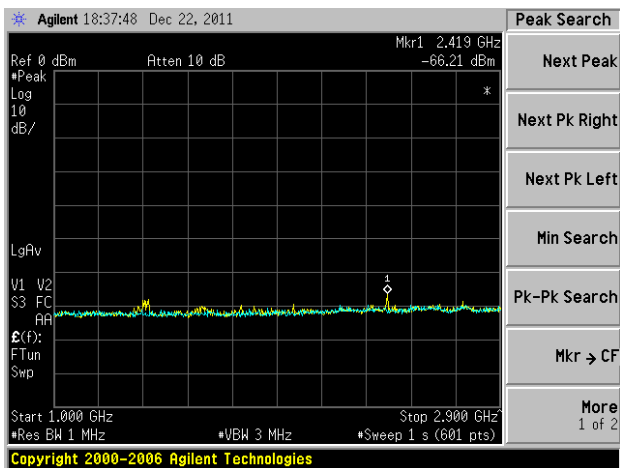

1GHz to 2.9GHz

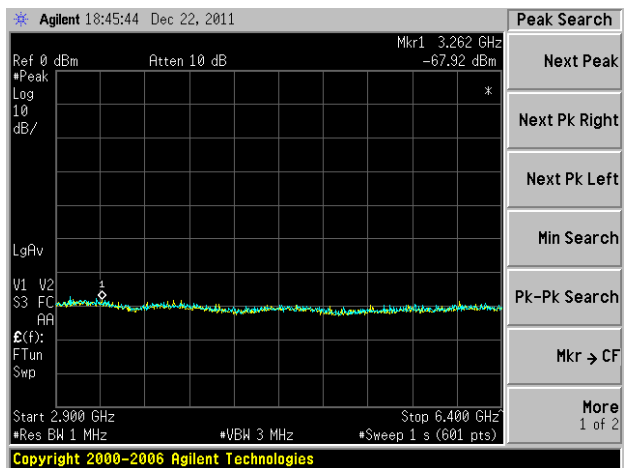

2.9GHz to 6.4GHz

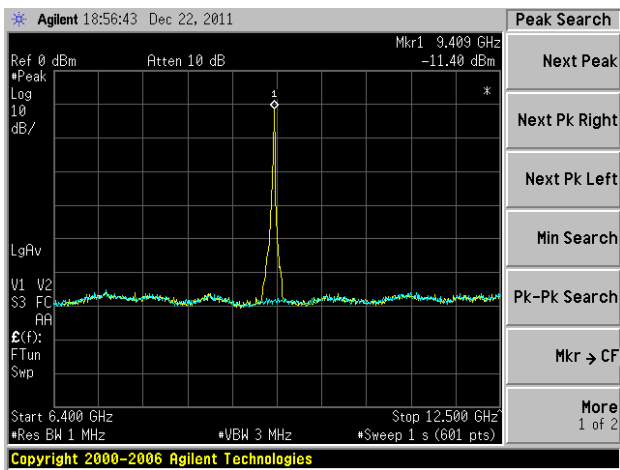

6.4GHz to 12.5GHz

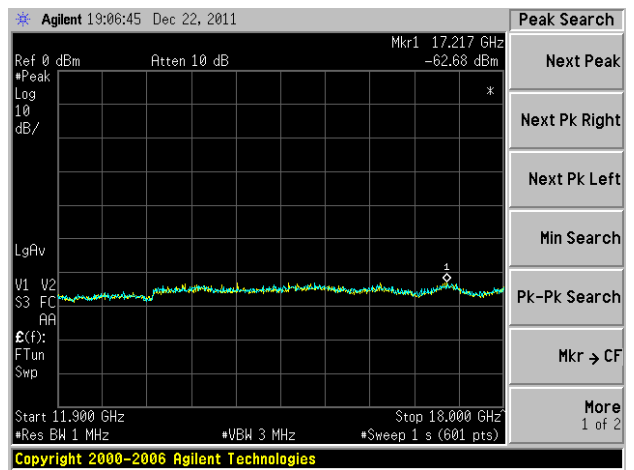

11.9GHz to 18GHz

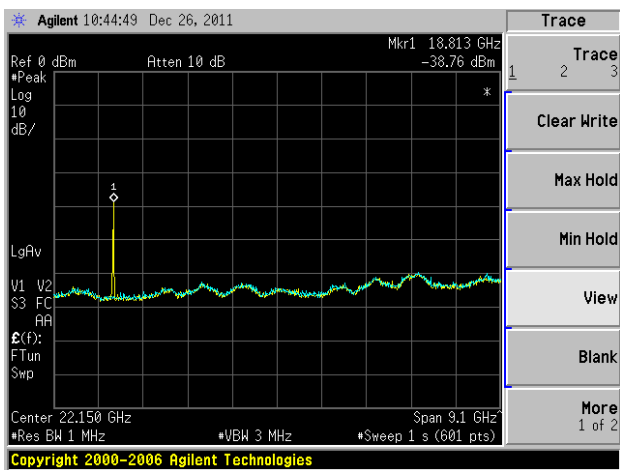

17.6GHz to 26.7GHz

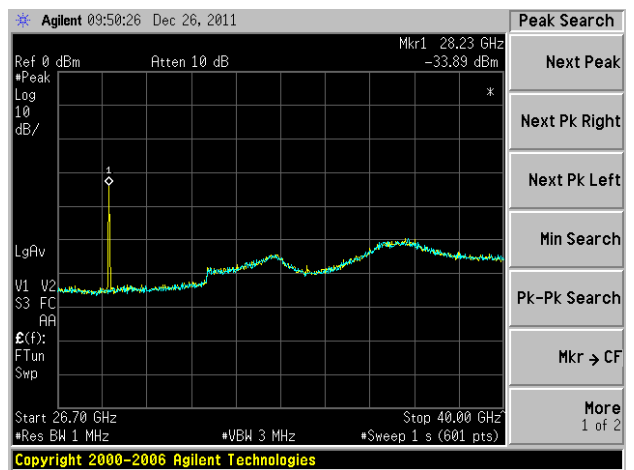

26.7GHz to 40.0GHz

·Vertically Polarized

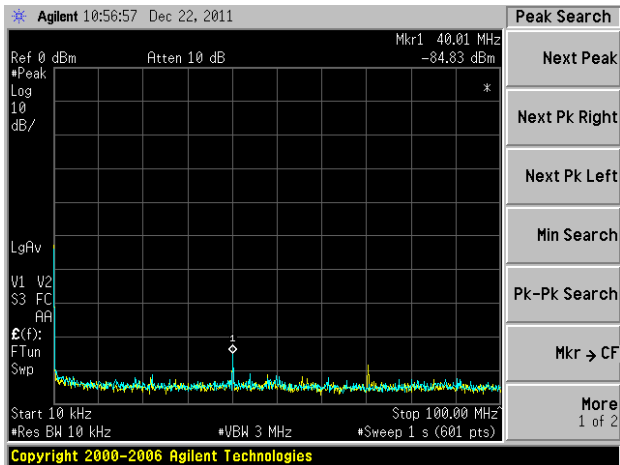

10kHz to 100MHz

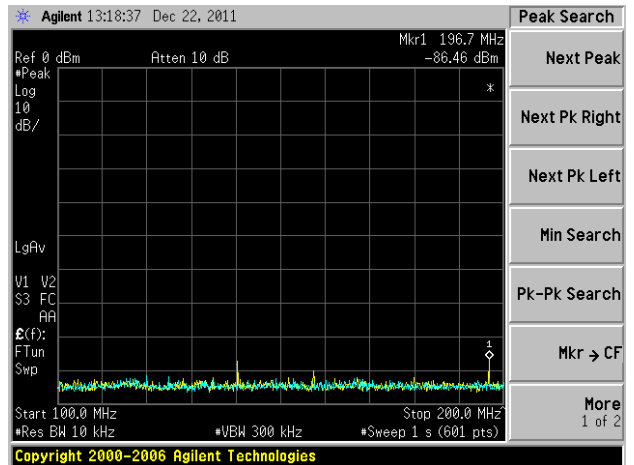

100MHz to 200MHz

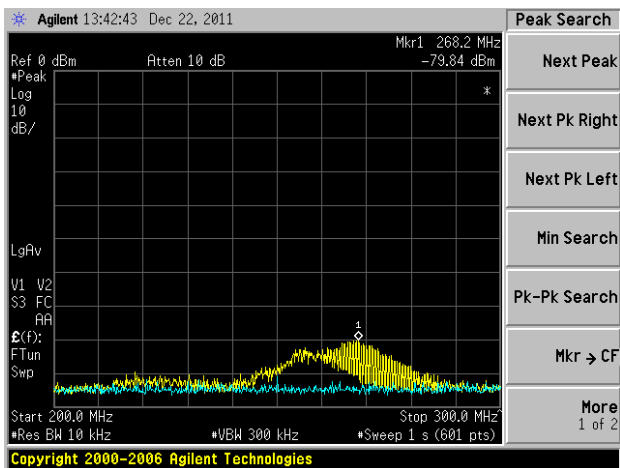

200MHz to 300MHz

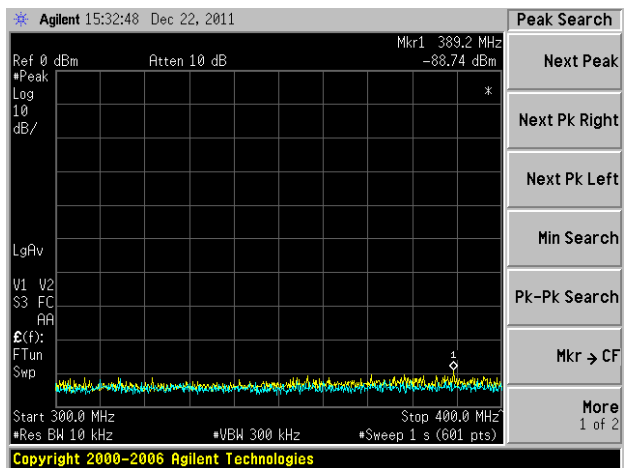

300MHz to 400MHz

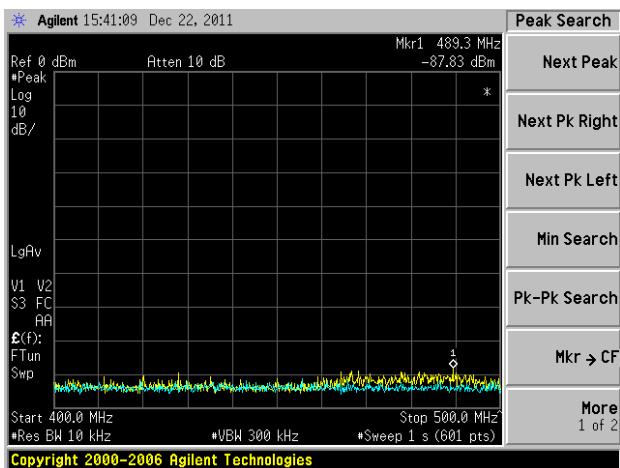

400MHz to 500MHz

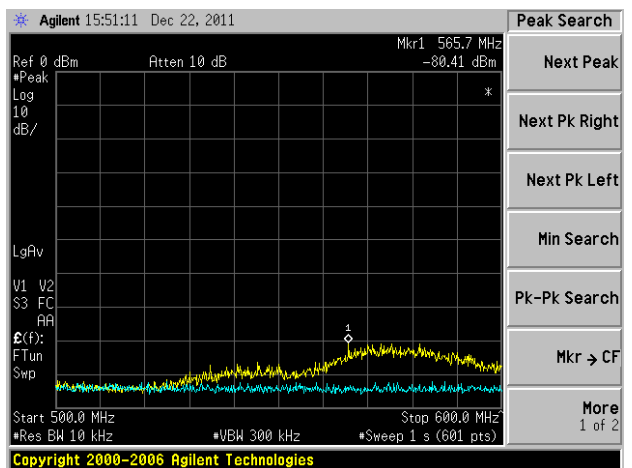

500MHz to 600MHz

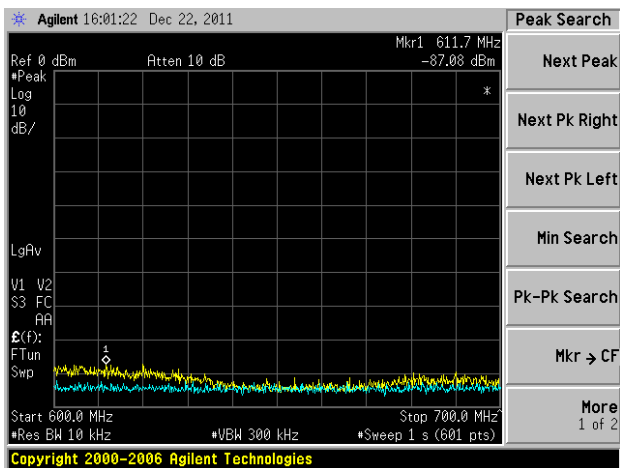

600MHz to 700MHz

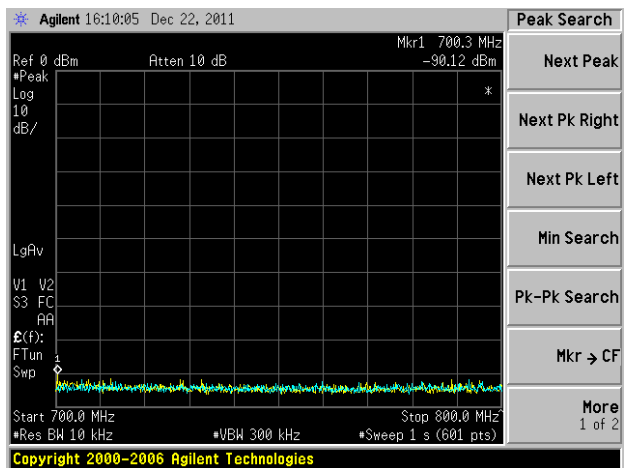

700MHz to 800MHz

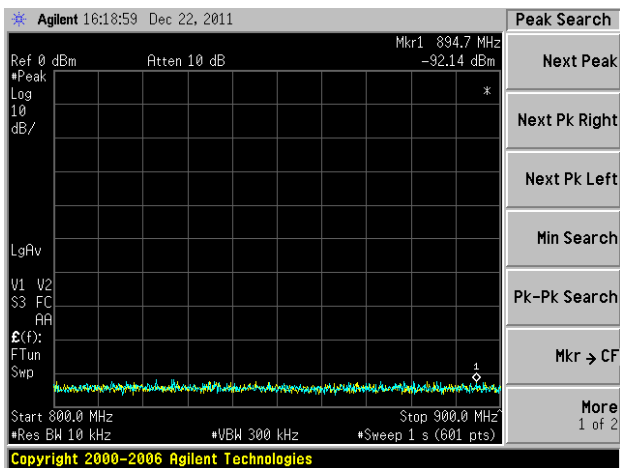

800MHz to 900MHz

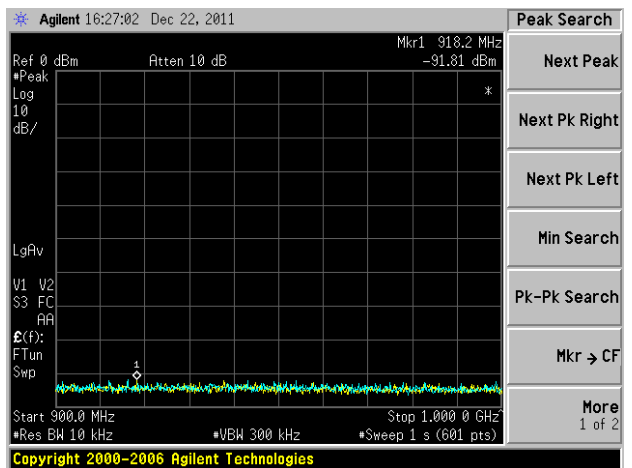

900MHz to 1GHz

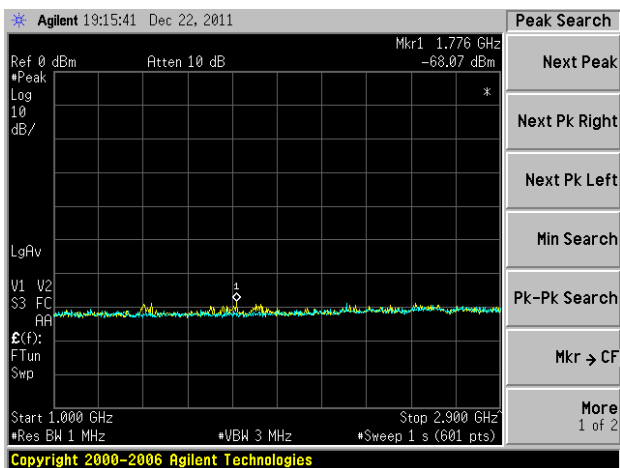

1GHz to 2.9GHz

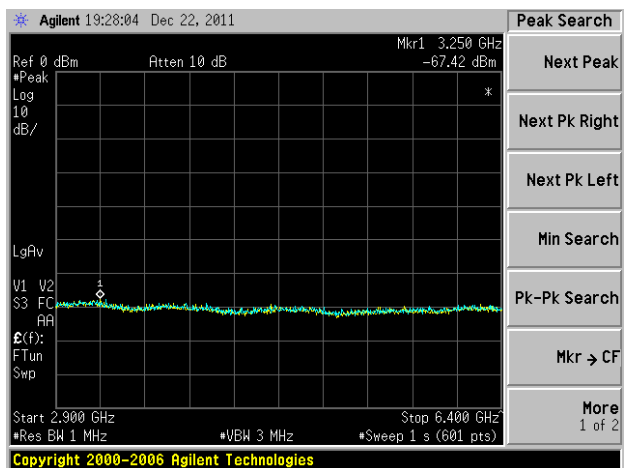

2.9GHz 6.4GHz

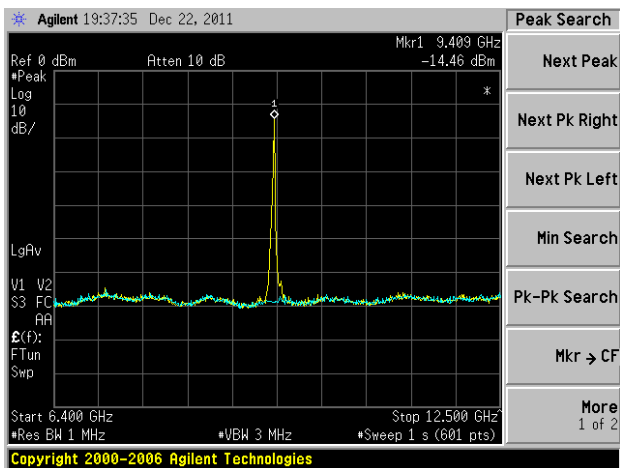

6.4GHz to 12.5GHz

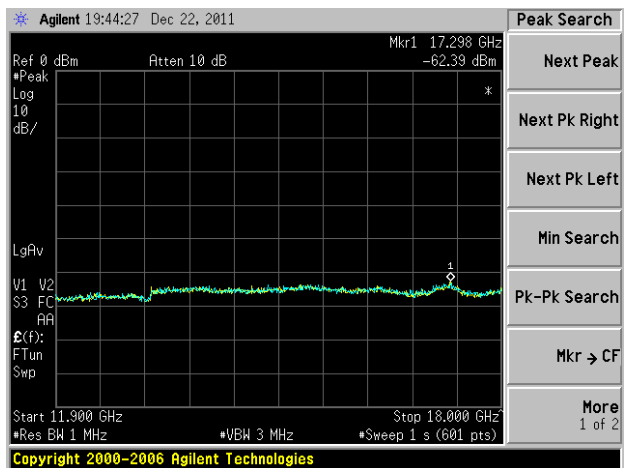

11.9GHz to 18.0GHz

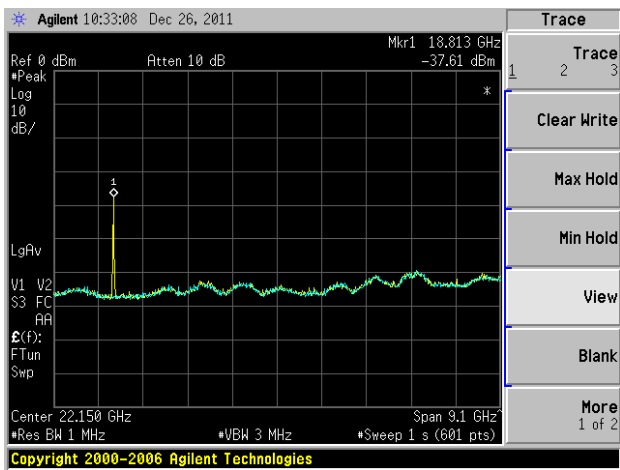

17.6GHz to 26.7GHz

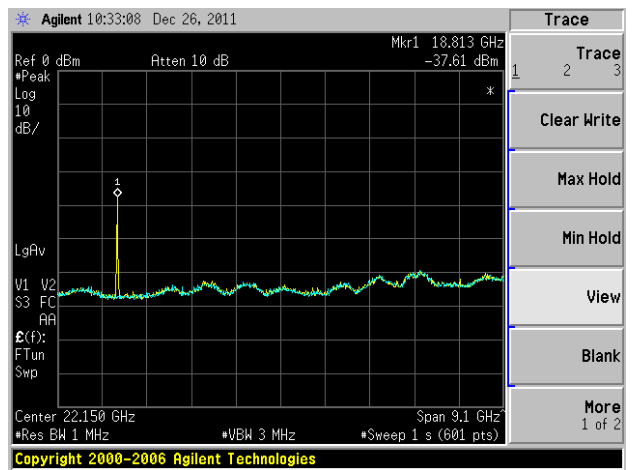

26.7GHz to 40GHz

4.4.10.7 TEST RESULTS of 0.5usec/1200Hz

Horizontally Polarized 0.5usec/1200Hz							
Range	Frequency [MHz]	level [dBm]	Pg [dBm]	Cable Loss [dB]	Antenna Gain [dB]	Pd [dBm]	Radiated Spurious Emission [dBc]
10kHz - 100MHz	47.84	-86.36	-63.9	0.5	-11.48	-75.9	-140.8
100MHz - 200MHz	157.3	-89.38	-74.0	0.5	-4.32	-78.8	-143.8
200MHz - 300MHz	267.5	-80.88	-43.7	0.5	-3.45	-47.7	-112.6
300MHz - 400MHz	311.8	-88.85	-76.5	0.5	2	-75.0	-140.0
400MHz - 500MHz	465.2	-77.83	-62.1	0.5	3.1	-59.5	-124.5
500MHz - 600MHz	507.5	-85.77	-70.2	0.5	3.1	-67.6	-132.6
600MHz - 700MHz	621.3	-88.6	-77.9	0.5	2.7	-75.7	-140.7
700MHz - 800MHz	734.5	-91.96	less than the noise floor	/	/	/	less than the noise floor
800MHz - 900MHz	842.3	-91.75	less than the noise floor	/	/	/	less than the noise floor
900MHz - 1.0GHz	910	-92.2	less than the noise floor	/	/	/	less than the noise floor
1.0GHz - 2.9GHz	2745	-69.23	less than the noise floor	/	/	/	less than the noise floor
2.9GHz - 6.4GHz	3168	-68.09	less than the noise floor	/	/	/	less than the noise floor
6.4GHz - 12.5GHz	9409	-6.25	less than the noise floor	/	/	/	less than the noise floor
11.9G - 18GHz	17166	-63.33	less than the noise floor	/	/	/	less than the noise floor
17.6G - 26.7GHz	18813	-34.42	-17.67	3	20	-0.7	-65.6
26.7G - 40.0GHz	28230	-29.22	-5.48	3	20	11.5	-53.4

Vertically Polarized 0.5usec/1200Hz							
Range	Frequency [MHz]	level [dBm]	Pg [dBm]	Cable Loss [dB]	Antenna Gain [dB]	Pd [dBm]	Radiated Spurious Emission [dBc]
10kHz - 100MHz	40.01	-84.97	-46.9	0.5	-15.39	-62.8	-127.7
100MHz - 200MHz	157.3	-85.22	-67.5	0.5	-4.32	-72.3	-137.3
200MHz - 300MHz	267.3	-79.23	-40.4	0.5	-3.45	-44.3	-109.3
300MHz - 400MHz	397.2	-87.96	-82	0.5	3.2	-79.3	-144.3
400MHz - 500MHz	478.8	-88.31	-75	0.5	3.1	-72.4	-137.4
500MHz - 600MHz	581.8	-81.1	-67.8	0.5	2.7	-65.6	-130.6
600MHz - 700MHz	611.7	-86.69	-75.81	0.5	2.55	-73.76	-138.7
700MHz - 800MHz	700.2	-88.51	less than the noise floor	/	/	/	less than the noise floor
800MHz - 900MHz	846.8	-91.85	less than the noise floor	/	/	/	less than the noise floor
900MHz - 1.0GHz	910.5	-90.74	less than the noise floor	/	/	/	less than the noise floor
1.0GHz - 2.9GHz	2720	-69.18	less than the noise floor	/	/	/	less than the noise floor
2.9GHz - 6.4GHz	3046	-67.45	less than the noise floor	/	/	/	less than the noise floor
6.4GHz - 12.5GHz	9409	-11.06	less than the noise floor	/	/	/	less than the noise floor
11.9G - 18GHz	15438	-63.3	less than the noise floor	/	/	/	less than the noise floor
17.6G - 26.7GHz	18813	-32.62	-15.87	3	20	1.1	-63.8
26.7G - 40.0GHz	28230	-31.82	-8.08	3	20	8.9	-56.0

• Horizontally Polarized

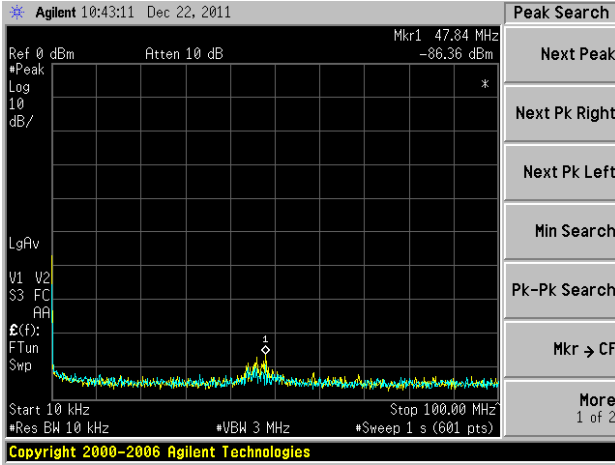

10kHz to 100MHz

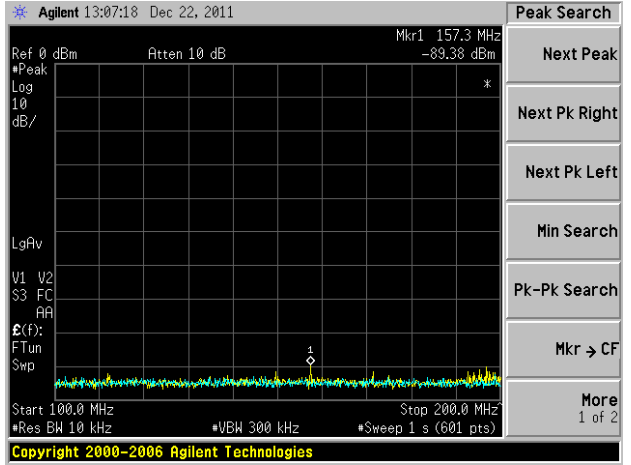

100MHz to 200MHz

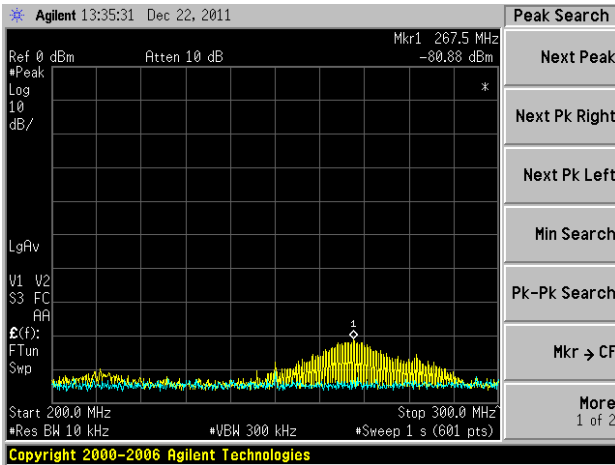

200MHz to 300MHz

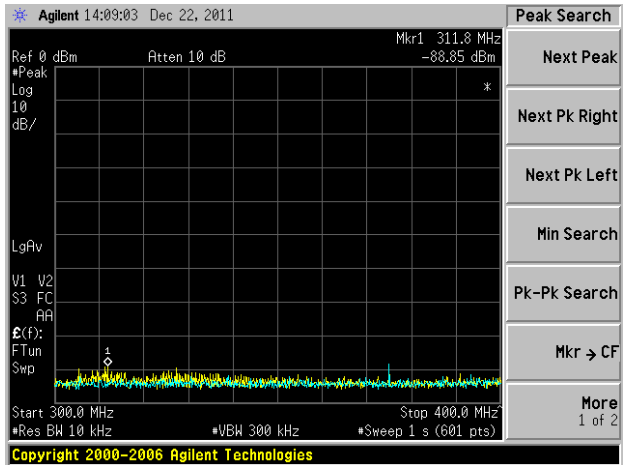

300MHz to 400MHz

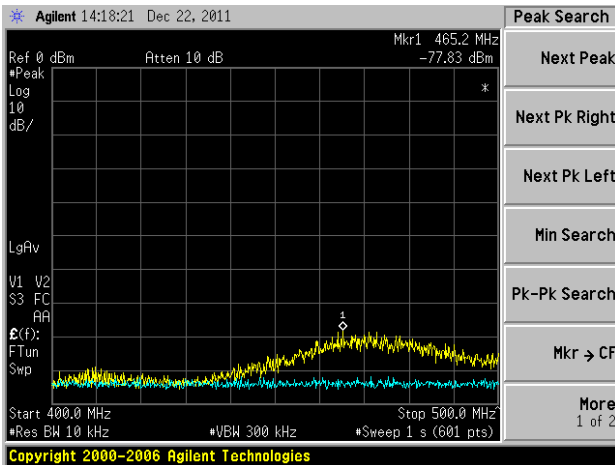

400MHz to 500MHz

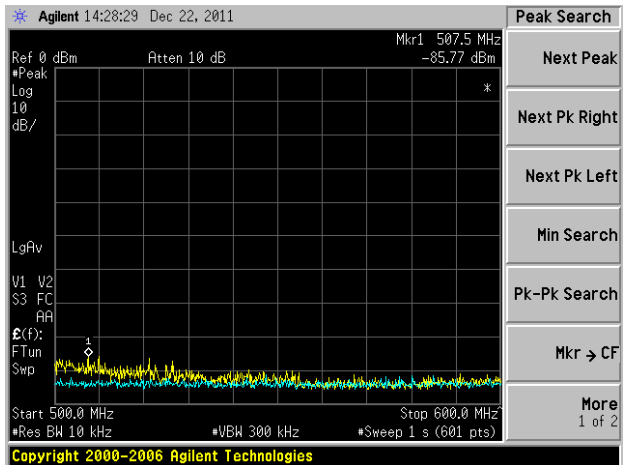

500MHz to 600MHz

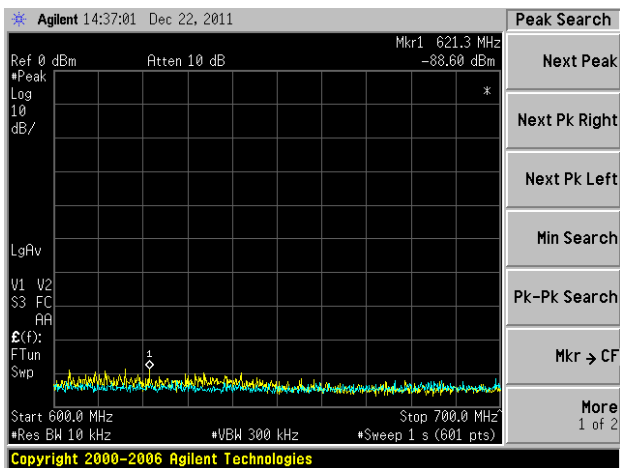

600MHz to 700MHz

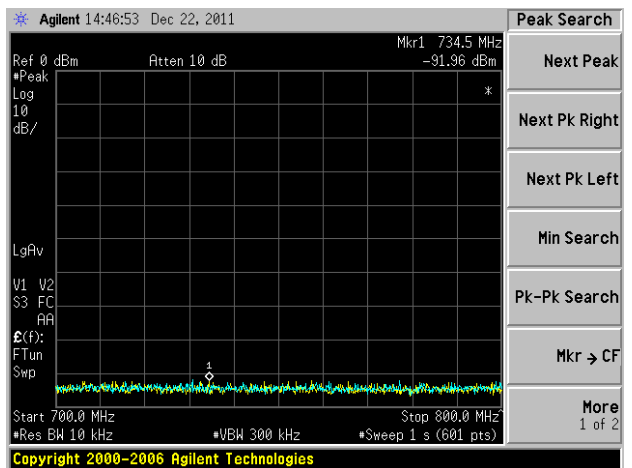

700MHz to 800MHz

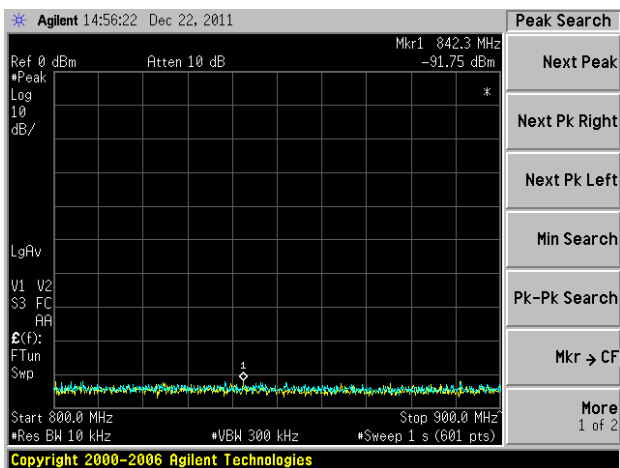

800MHz to 900MHz

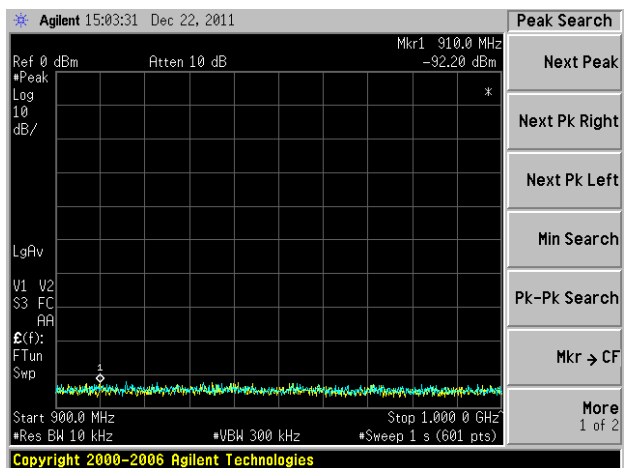

900MHz to 1GHz

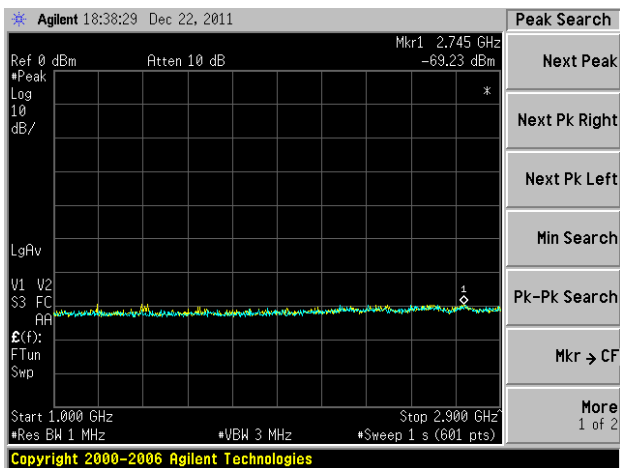

1GHz to 2.9GHz

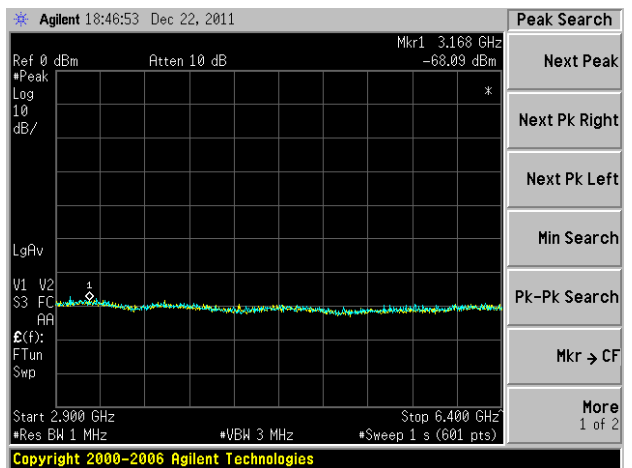

2.9GHz to 6.4GHz

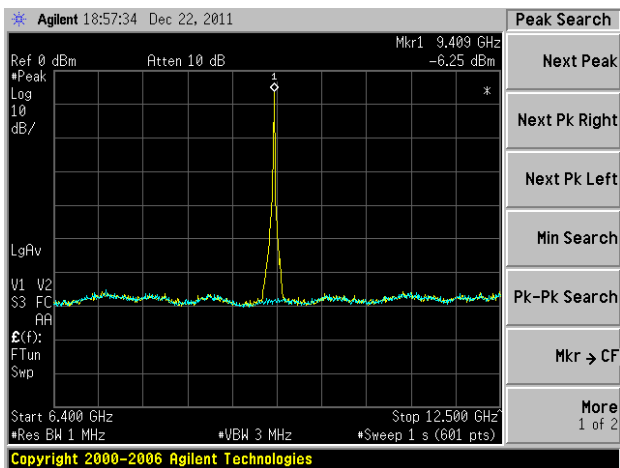

6.4GHz to 12.5GHz

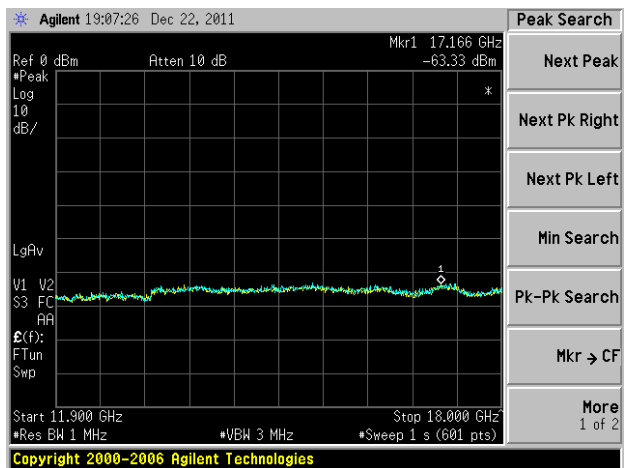

11.9GHz to 18GHz

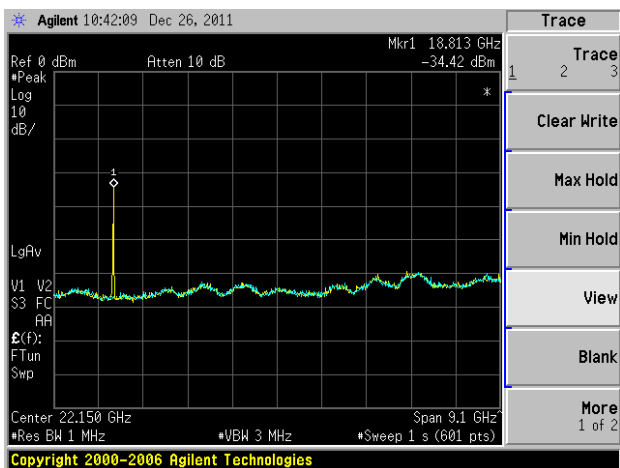

17.6GHz to 26.7GHz

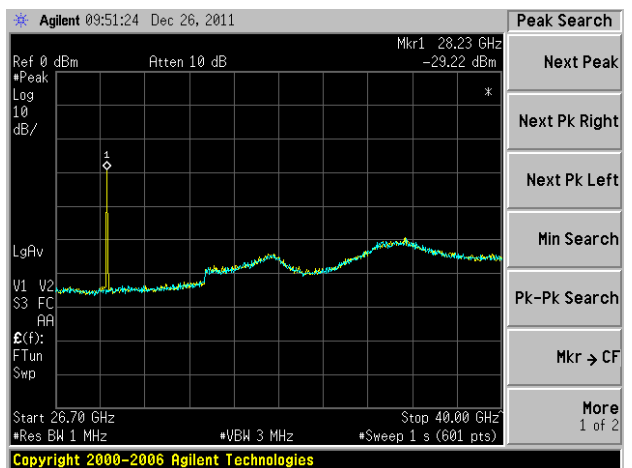

26.7GHz to 40.0GHz

·Vertically Polarized

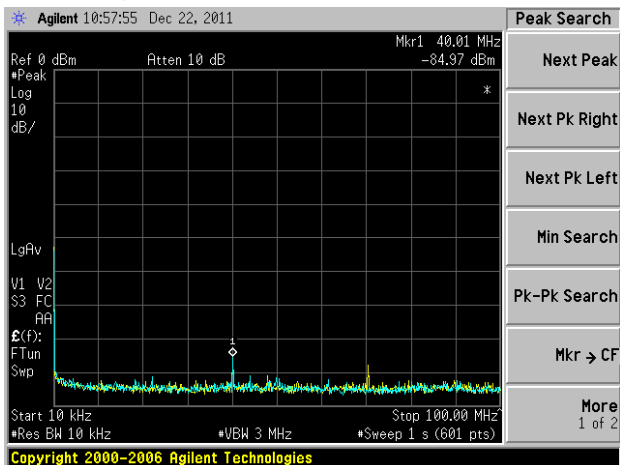

10kHz to 100MHz

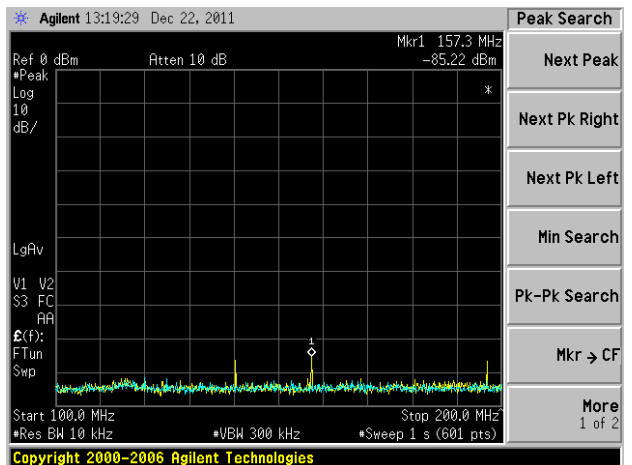

100MHz to 200MHz

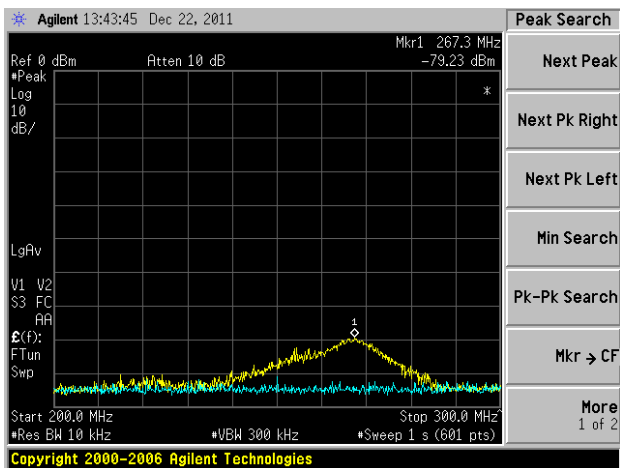

200MHz to 300MHz

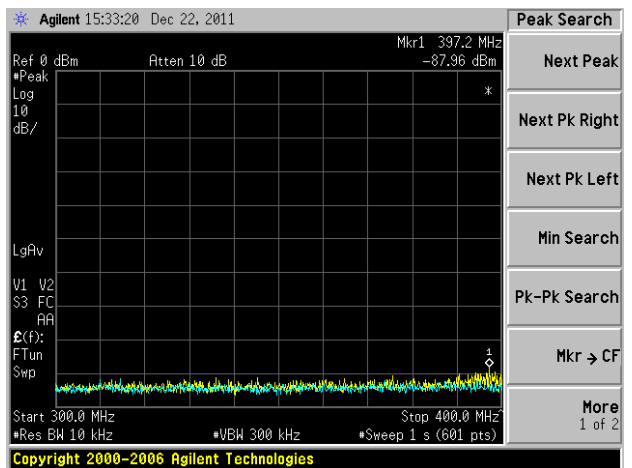

300MHz to 400MHz

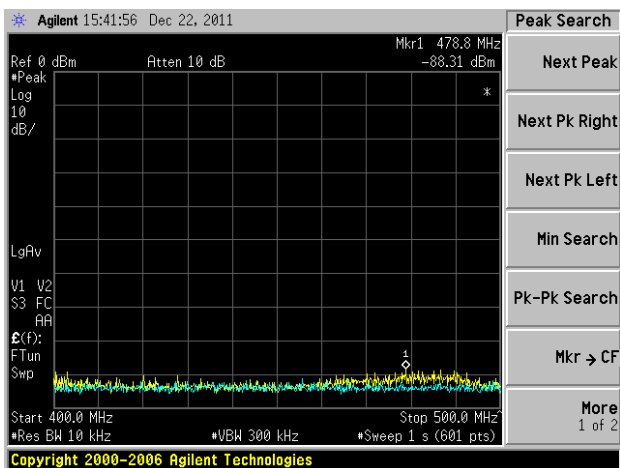

400MHz to 500MHz

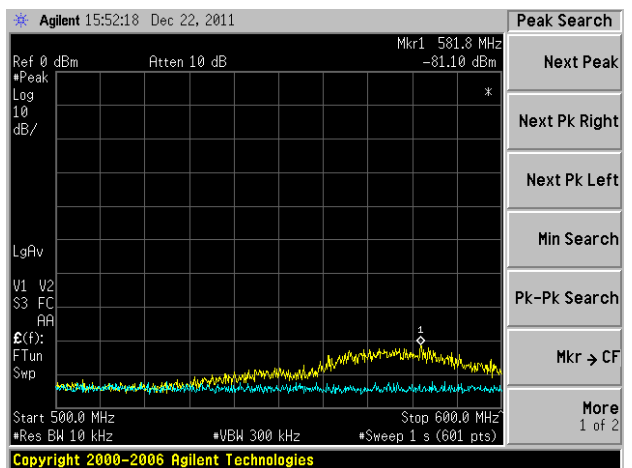

500MHz to 600MHz

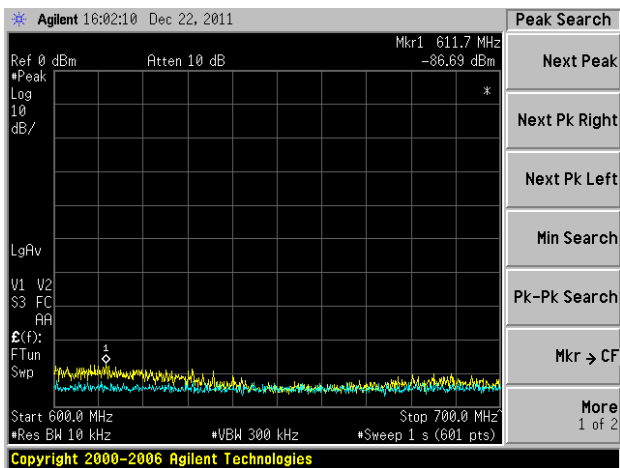

600MHz to 700MHz

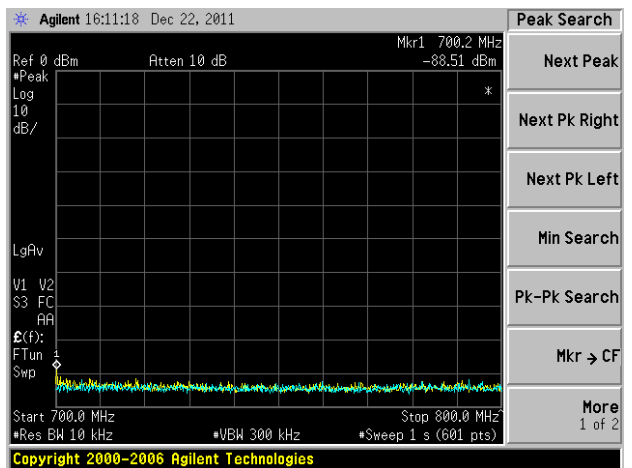

700MHz to 800MHz

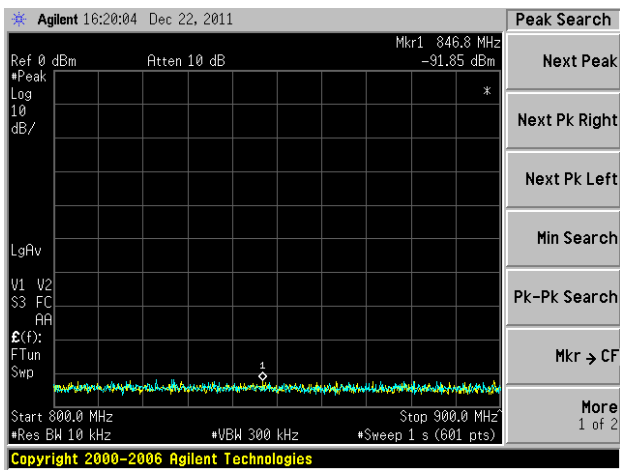

800MHz to 900MHz

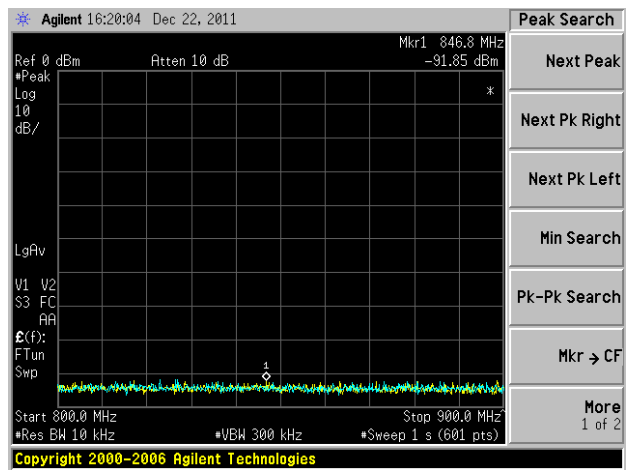

900MHz to 1GHz

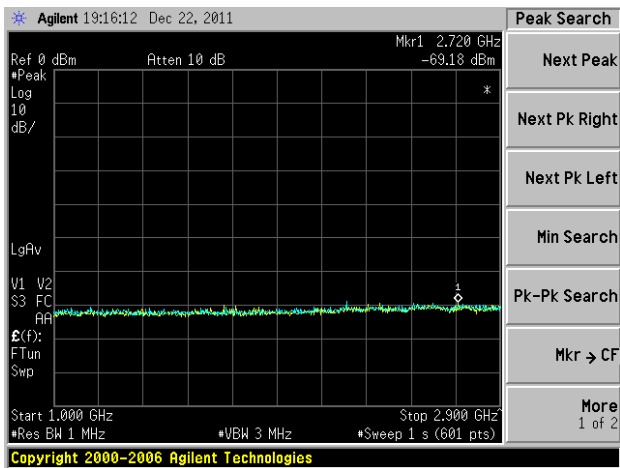

1GHz to 2.9GHz

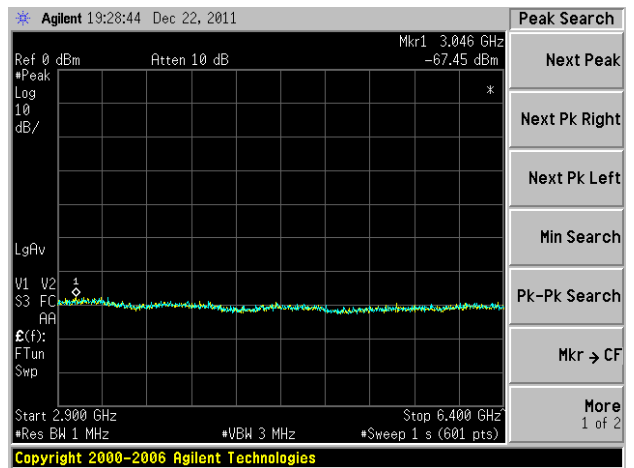

2.9GHz 6.4GHz

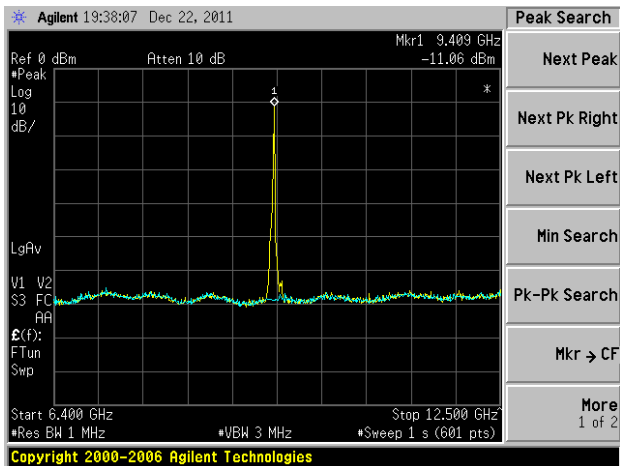

6.4GHz to 12.5GHz

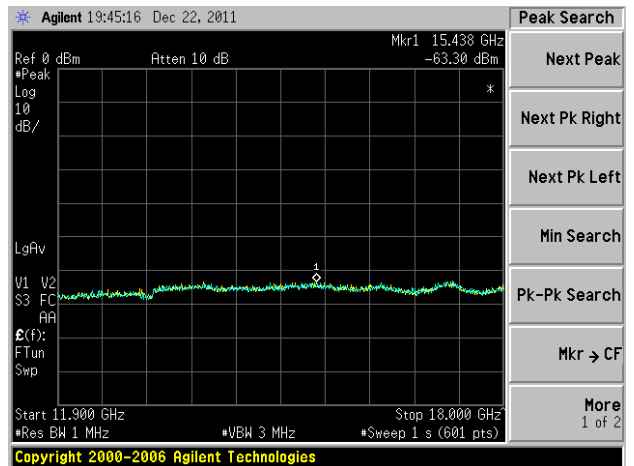

11.9GHz to 18.0GHz

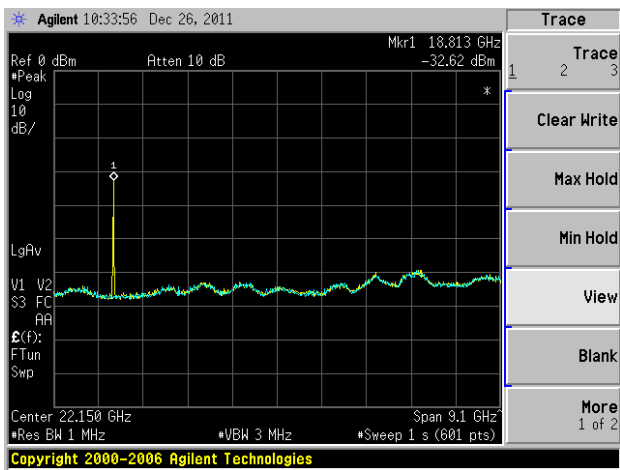

17.6GHz to 26.7GHz

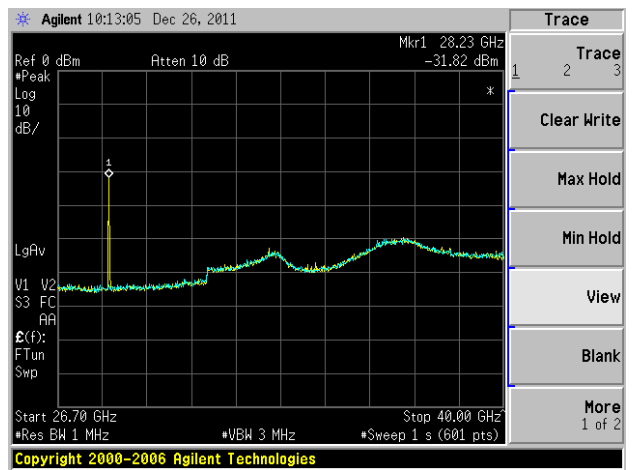

26.7GHz to 40GHz

4.4.10.8 TEST RESULTS of 0.8usec/750Hz

Horizontally Polarized 0.8usec/750Hz							
Range	Frequency [MHz]	level [dBm]	Pg [dBm]	Cable Loss [dB]	Antenna Gain [dB]	Pd [dBm]	Radiated Spurious Emission [dBc]
10kHz - 100MHz	47.84	-86.7	-64.2	0.5	-11.48	-76.2	-141.2
100MHz - 200MHz	157.3	-89.05	-73.7	0.5	-4.32	-78.5	-143.4
200MHz - 300MHz	266.2	-81.08	-44.6	0.5	-3.45	-48.6	-113.5
300MHz - 400MHz	375	-88.74	less than the noise floor	/	/	/	less than the noise floor
400MHz - 500MHz	472.2	-78.11	-61.4	0.5	3.1	-58.8	-123.8
500MHz - 600MHz	501	-87.07	-71.9	0.5	3.1	-69.3	-134.3
600MHz - 700MHz	609.2	-88.89	-79.9	0.5	2.8	-77.6	-142.6
700MHz - 800MHz	732.5	-91.6	less than the noise floor	/	/	/	less than the noise floor
800MHz - 900MHz	845.5	-92.06	less than the noise floor	/	/	/	less than the noise floor
900MHz - 1.0GHz	977.2	-91.82	less than the noise floor	/	/	/	less than the noise floor
1.0GHz - 2.9GHz	2574	-67.95	less than the noise floor	/	/	/	less than the noise floor
2.9GHz - 6.4GHz	6278	-64.22	less than the noise floor	/	/	/	less than the noise floor
6.4GHz - 12.5GHz	9409	-4.98	less than the noise floor	/	/	/	less than the noise floor
11.9G - 18GHz	15296	-63.56	less than the noise floor	/	/	/	less than the noise floor
17.6G - 26.7GHz	18813	-33.01	-16.26	3	20	0.7	-64.2
26.7G - 40.0GHz	28230	-30.44	-6.7	3	20	10.3	-54.7

Vertically Polarized 0.8usec/750Hz							
Range	Frequency [MHz]	level [dBm]	Pg [dBm]	Cable Loss [dB]	Antenna Gain [dB]	Pd [dBm]	Radiated Spurious Emission [dBc]
10kHz - 100MHz	40.01	-84.87	-46.8	0.5	-15.39	-62.7	-127.6
100MHz - 200MHz	140.3	-85.76	-67.2	0.5	-4.48	-72.1	-137.1
200MHz - 300MHz	267.3	-79.44	-40.6	0.5	-3.45	-44.5	-109.5
300MHz - 400MHz	400	-89.04	-84.3	0.5	3.2	-81.6	-146.6
400MHz - 500MHz	469.5	-88.55	-77	0.5	3.1	-74.4	-139.4
500MHz - 600MHz	575.5	-81	-67.8	0.5	2.7	-65.6	-130.6
600MHz - 700MHz	610.2	-86.65	-76.2	0.5	2.55	-74.2	-139.1
700MHz - 800MHz	700.8	-91.19	less than the noise floor	/	/	/	less than the noise floor
800MHz - 900MHz	887.2	-91.14	less than the noise floor	/	/	/	less than the noise floor
900MHz - 1.0GHz	975.5	-92	less than the noise floor	/	/	/	less than the noise floor
1.0GHz - 2.9GHz	1868	-69.34	less than the noise floor	/	/	/	less than the noise floor
2.9GHz - 6.4GHz	3232	-67.58	less than the noise floor	/	/	/	less than the noise floor
6.4GHz - 12.5GHz	9409	-10.49	less than the noise floor	/	/	/	less than the noise floor
11.9G - 18GHz	17156	-62.93	less than the noise floor	/	/	/	less than the noise floor
17.6G - 26.7GHz	18813	-31.32	-14.57	3	20	2.4	-62.5
26.7G - 40.0GHz	28230	-35.8	-12.06	3	20	4.9	-60.0

·Horizontally Polarized

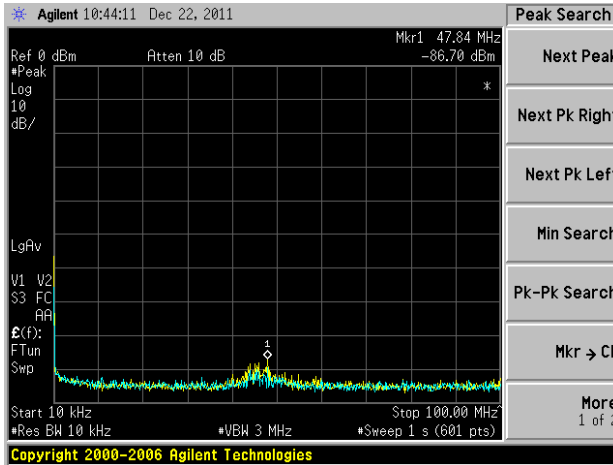

10kHz to 100MHz

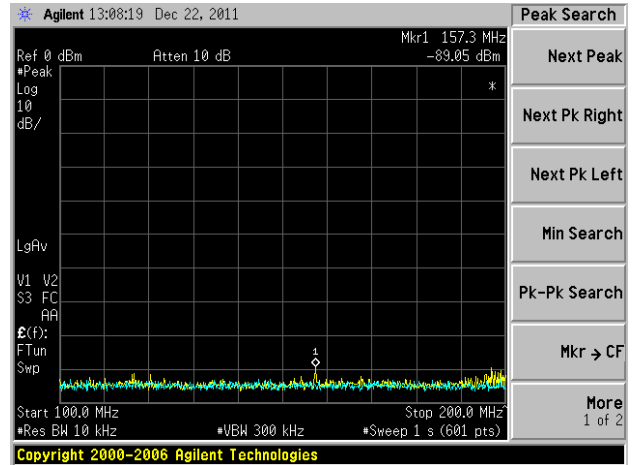

100MHz to 200MHz

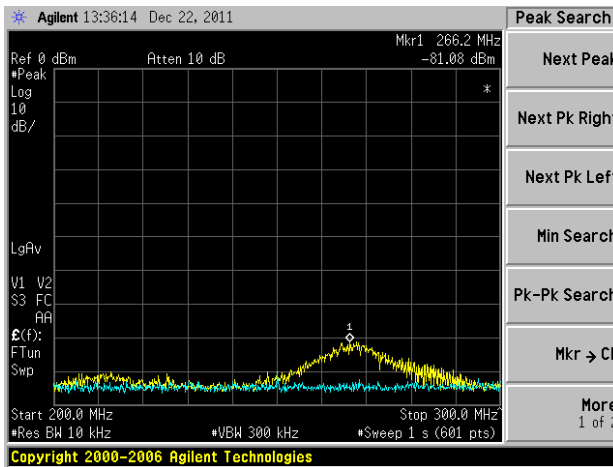

200MHz to 300MHz

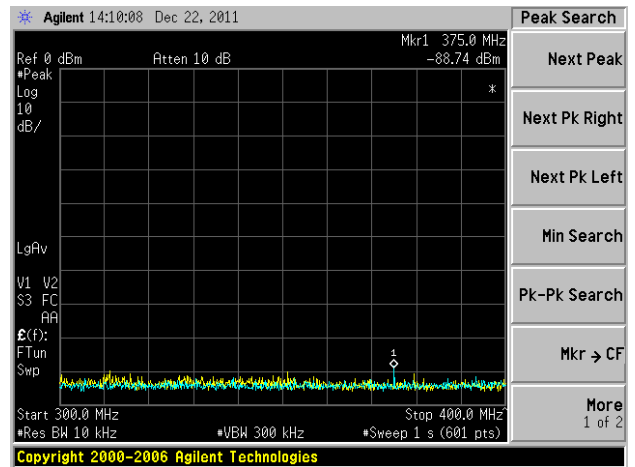

300MHz to 400MHz

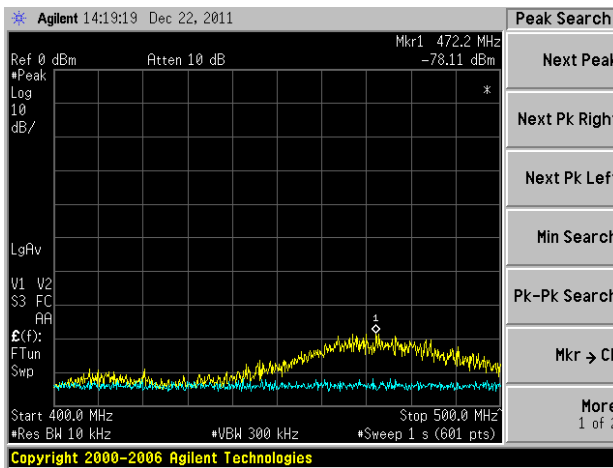

400MHz to 500MHz

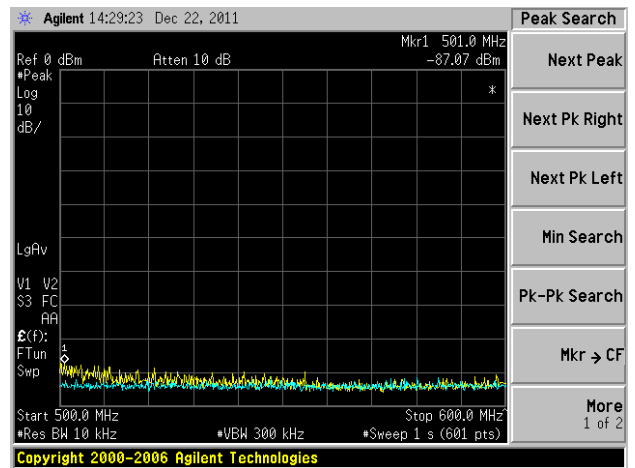

500MHz to 600MHz

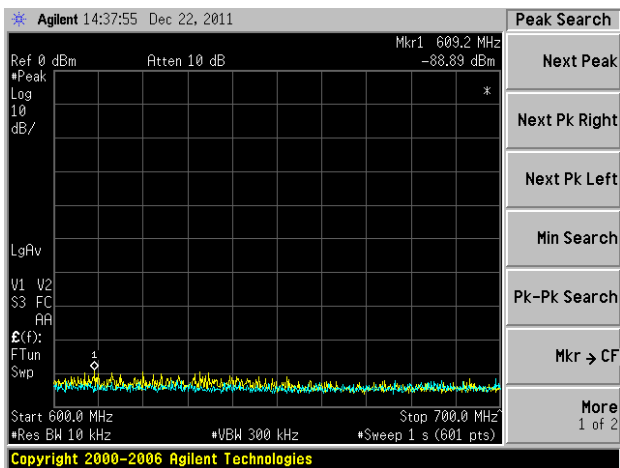

600MHz to 700MHz

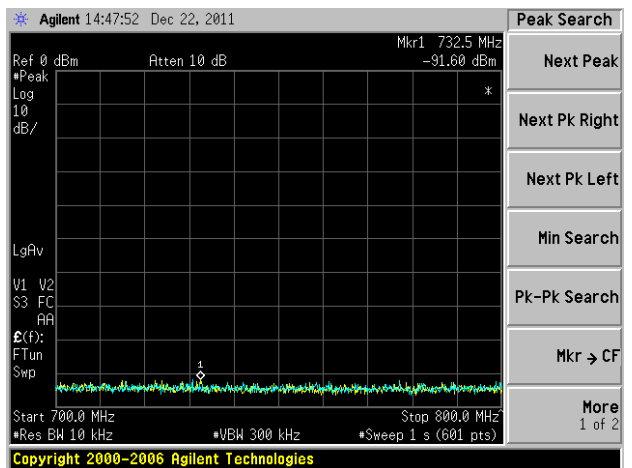

700MHz to 800MHz

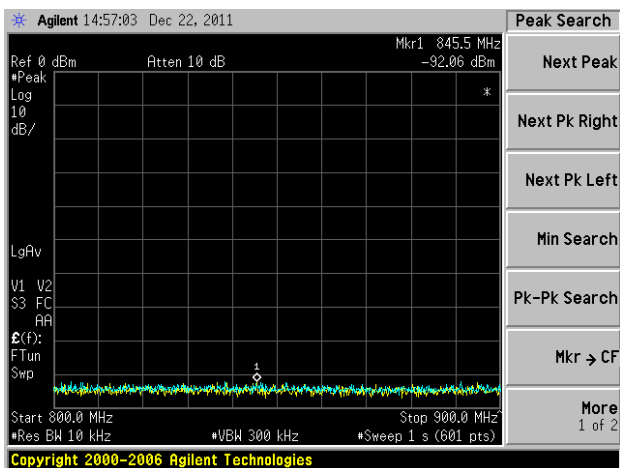

800MHz to 900MHz

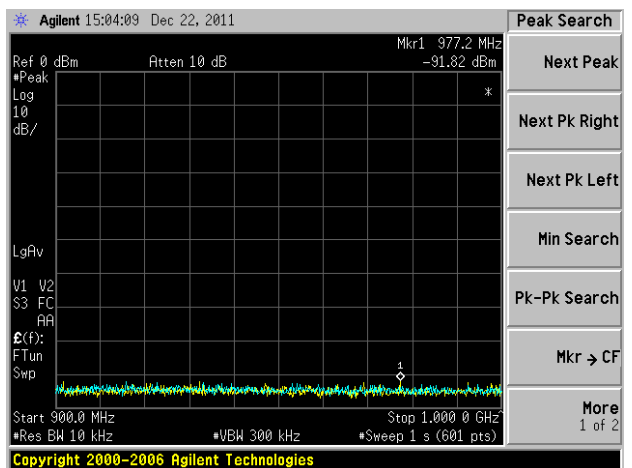

900MHz to 1GHz

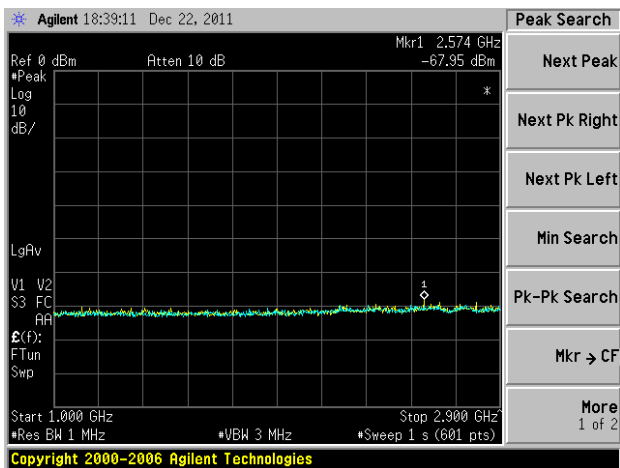

1GHz to 2.9GHz

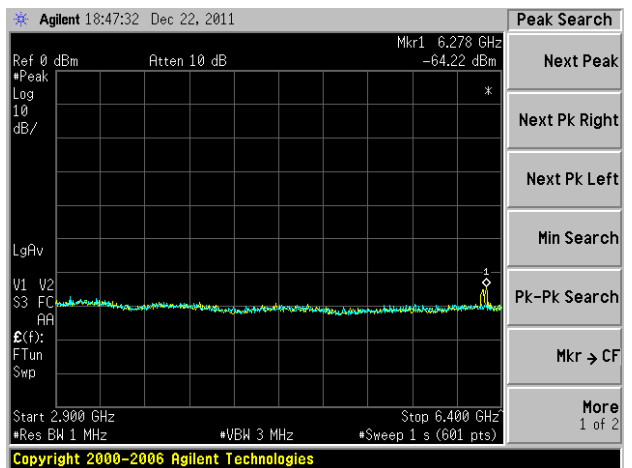

2.9GHz to 6.4GHz

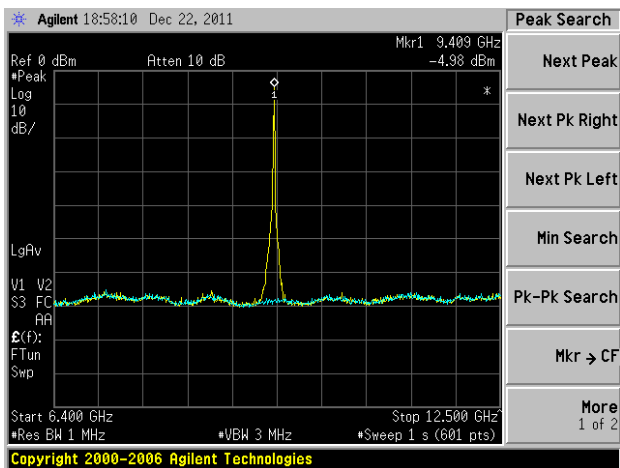

6.4GHz to 12.5GHz

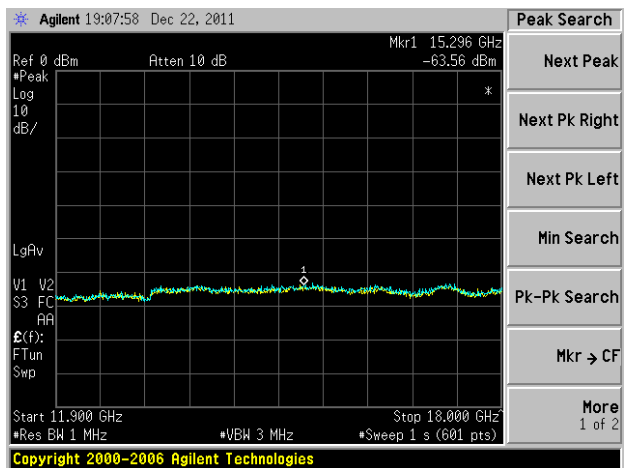

11.9GHz to 18GHz

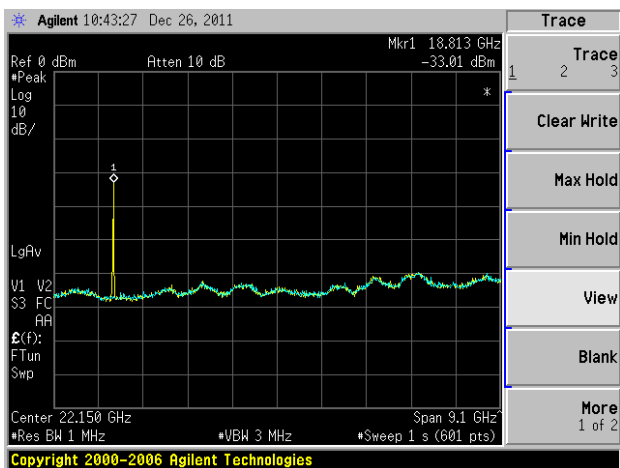

17.6GHz to 26.7GHz

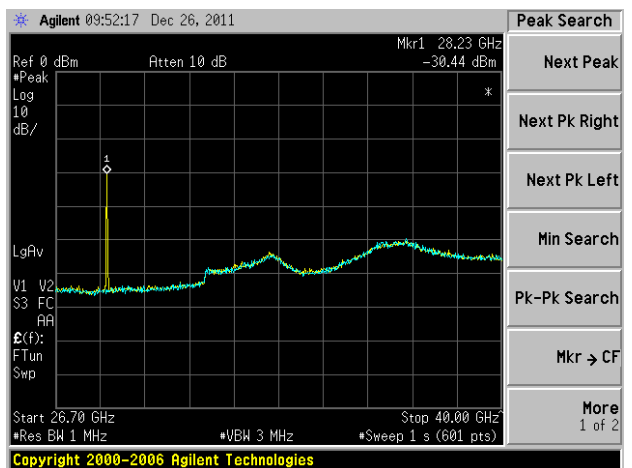

26.7GHz to 40.0GHz

·Vertically Polarized

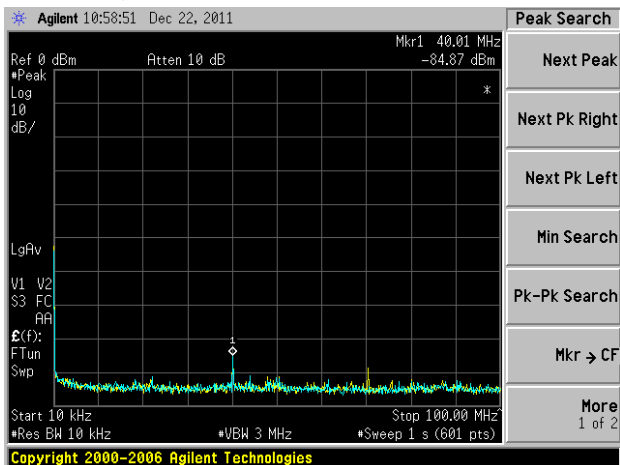

10kHz to 100MHz

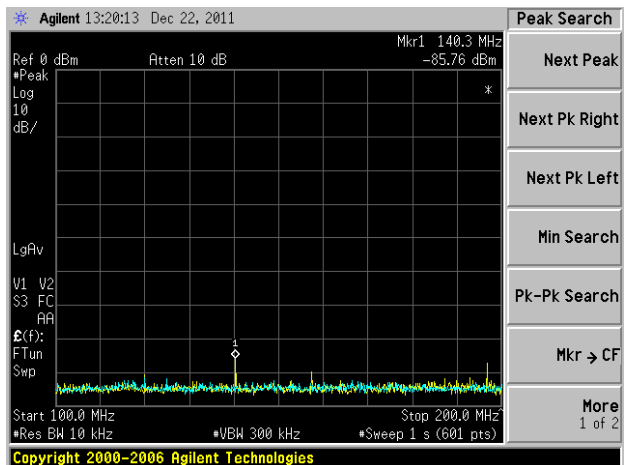

100MHz to 200MHz

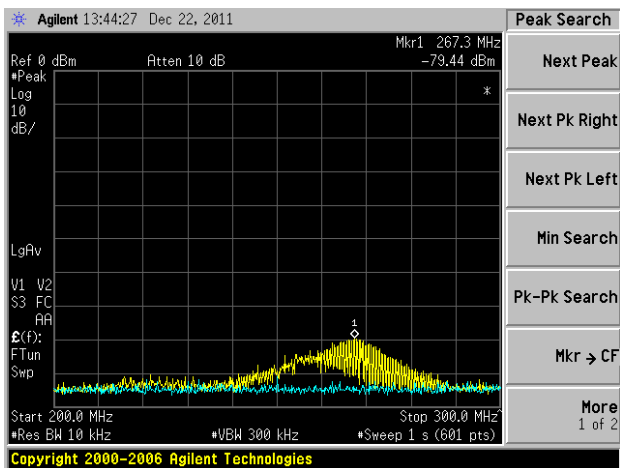

200MHz to 300MHz

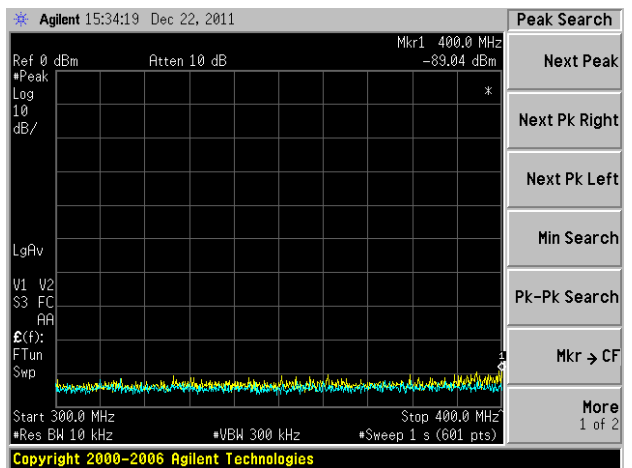

300MHz to 400MHz

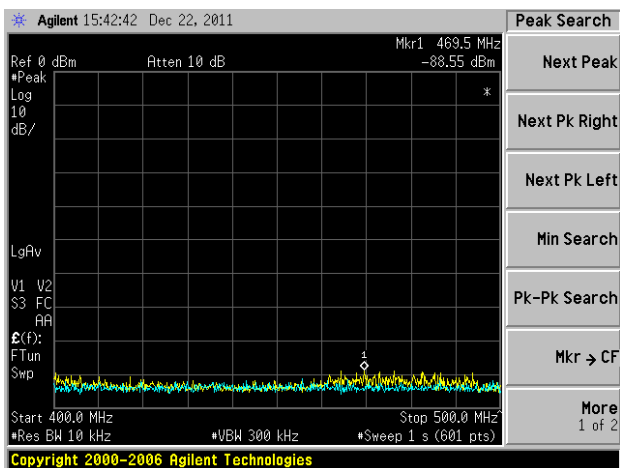

400MHz to 500MHz

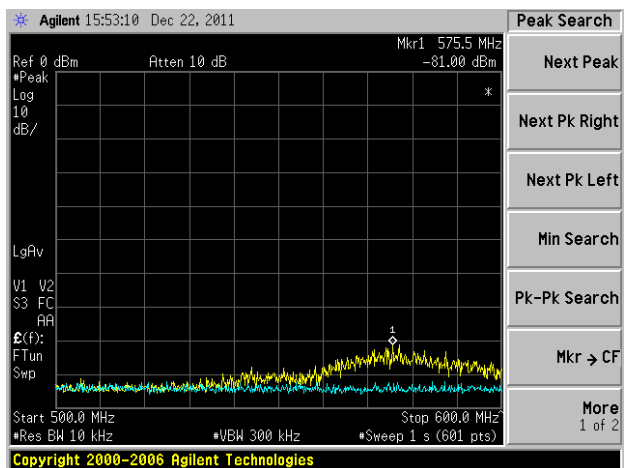

500MHz to 600MHz

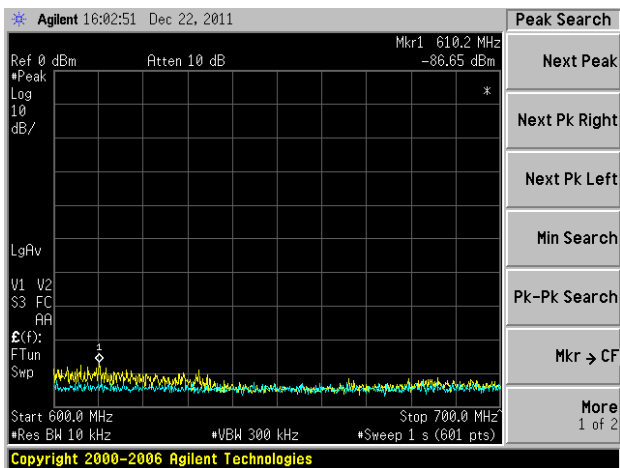

600MHz to 700MHz

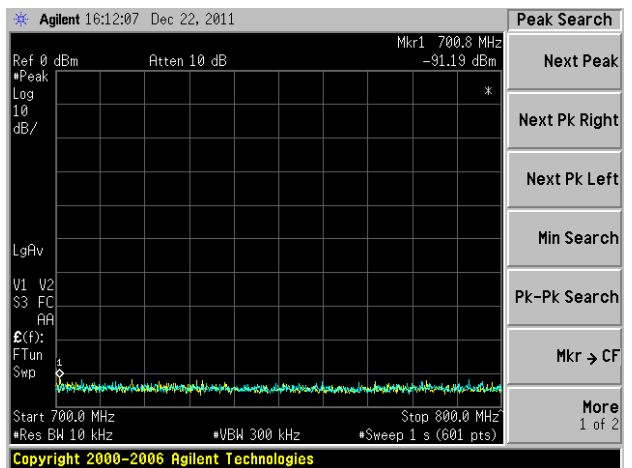

700MHz to 800MHz

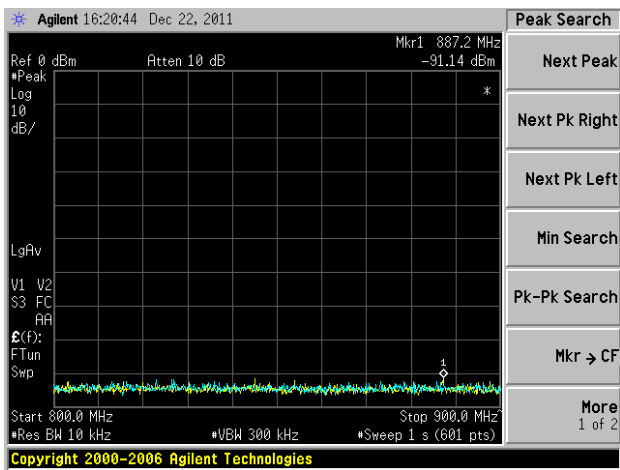

800MHz to 900MHz

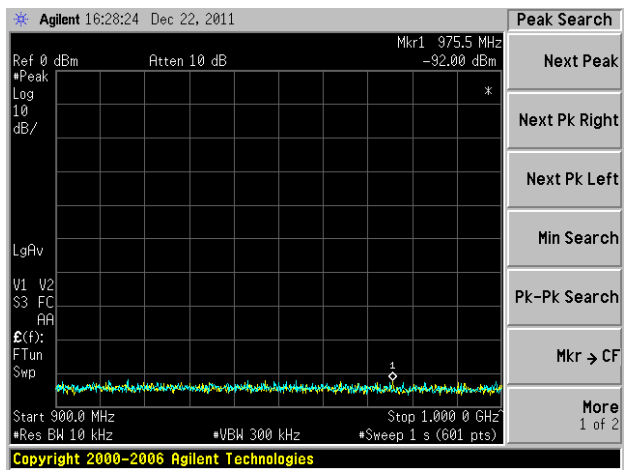

900MHz to 1GHz

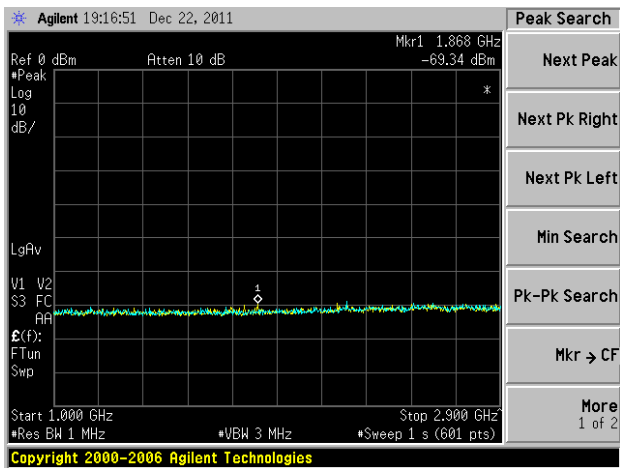

1GHz to 2.9GHz

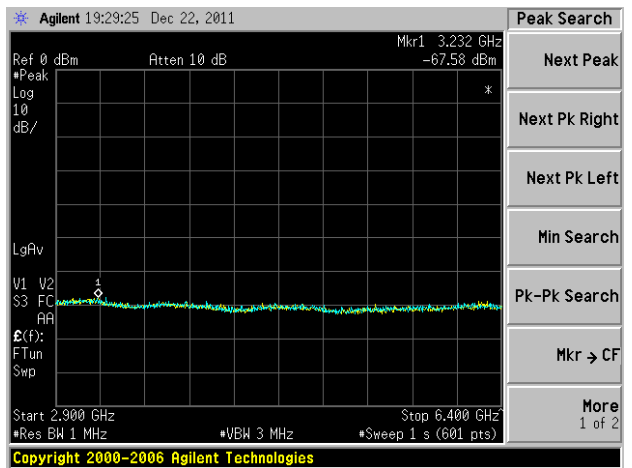

2.9GHz 6.4GHz

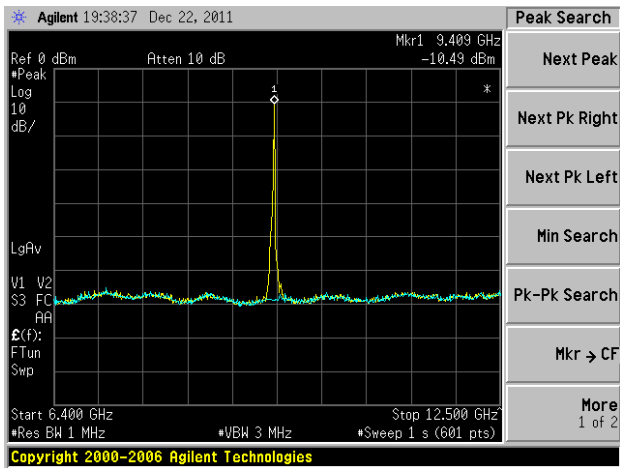

6.4GHz to 12.5GHz

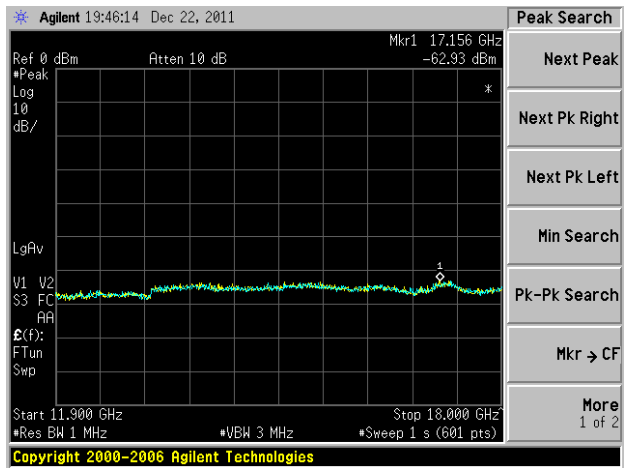

11.9GHz to 18.0GHz

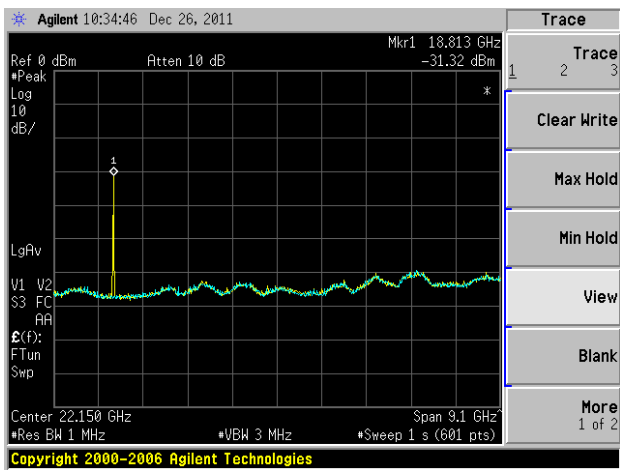

17.6GHz to 26.7GHz

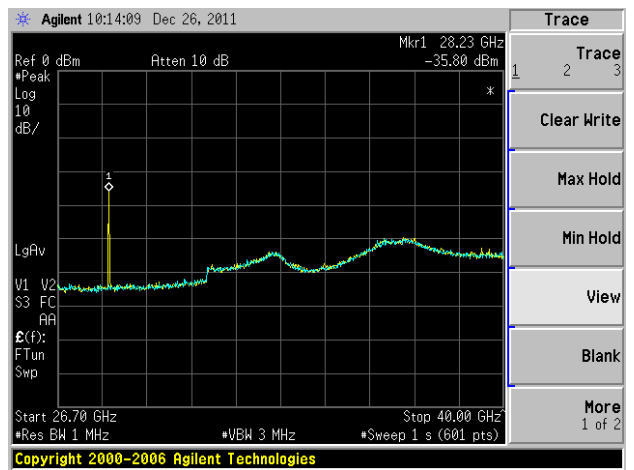

26.7GHz to 40GHz

4.4.10.9 TEST RESULTS of 1.0usec/650Hz

Horizontally Polarized 1.0usec/650Hz							
Range	Frequency [MHz]	level [dBm]	Pg [dBm]	Cable Loss [dB]	Antenna Gain [dB]	Pd [dBm]	Radiated Spurious Emission [dBc]
10kHz - 100MHz	47.84	-85.96	-63.5	0.5	-11.48	-75.5	-140.4
100MHz - 200MHz	157.3	-89.39	-74.0	0.5	-4.32	-78.8	-143.8
200MHz - 300MHz	267.7	-81.56	-45.0	0.5	-3.45	-49.0	-113.9
300MHz - 400MHz	310.7	-85.9	-70	0.5	2.1	-68.4	-133.4
400MHz - 500MHz	470	-79.44	-63.3	0.5	3.1	-60.7	-125.7
500MHz - 600MHz	509	-86.56	-71.1	0.5	3.1	-68.5	-133.5
600MHz - 700MHz	630.2	-89.48	-79.1	0.5	2.4	-77.2	-142.2
700MHz - 800MHz	714.8	-91.4	less than the noise floor	/	/	/	less than the noise floor
800MHz - 900MHz	898.2	-92.08	less than the noise floor	/	/	/	less than the noise floor
900MHz - 1.0GHz	924.5	-90.94	less than the noise floor	/	/	/	less than the noise floor
1.0GHz - 2.9GHz	2732	-69	less than the noise floor	/	/	/	less than the noise floor
2.9GHz - 6.4GHz	6272	-61.46	less than the noise floor	/	/	/	less than the noise floor
6.4GHz - 12.5GHz	9409	-5.26	less than the noise floor	/	/	/	less than the noise floor
11.9G - 18GHz	15.438	-63.2	less than the noise floor	/	/	/	less than the noise floor
17.6G - 26.7GHz	18813	-34.61	-17.86	3	20	-0.9	-65.8
26.7G - 40.0GHz	28230	-32.64	-8.9	3	20	8.1	-56.9

Vertically Polarized 1.0usec/650Hz							
Range	Frequency [MHz]	level [dBm]	Pg [dBm]	Cable Loss [dB]	Antenna Gain [dB]	Pd [dBm]	Radiated Spurious Emission [dBc]
10kHz - 100MHz	40.01	-85.54	-47.5	0.5	-15.39	-63.4	-128.3
100MHz - 200MHz	140.3	-86.31	-67.7	0.5	-4.48	-72.7	-137.6
200MHz - 300MHz	267.3	-79.17	-40.3	0.5	-3.45	-44.3	-109.2
300MHz - 400MHz	396	-87.7	-81.5	0.5	3.2	-78.8	-143.8
400MHz - 500MHz	417.5	-89.78	-83.5	0.5	3.2	-80.8	-145.8
500MHz - 600MHz	576	-82.53	-69.7	0.5	2.7	-67.5	-132.5
600MHz - 700MHz	604.7	-87.4	-86.36	0.5	2.6	-84.26	-149.2
700MHz - 800MHz	706.7	-91.98	less than the noise floor	/	/	/	less than the noise floor
800MHz - 900MHz	817.8	-91.03	less than the noise floor	/	/	/	less than the noise floor
900MHz - 1.0GHz	930.8	-92.11	less than the noise floor	/	/	/	less than the noise floor
1.0GHz - 2.9GHz	2510	-65.37	less than the noise floor	/	/	/	less than the noise floor
2.9GHz - 6.4GHz	3058	-67.95	less than the noise floor	/	/	/	less than the noise floor
6.4GHz - 12.5GHz	9409	-9.08	less than the noise floor	/	/	/	less than the noise floor
11.9G - 18GHz	15570	-62.43	less than the noise floor	/	/	/	less than the noise floor
17.6G - 26.7GHz	18813	-32.66	-15.91	3	20	1.1	-63.9
26.7G - 40.0GHz	28230	-32.8	-9.06	3	20	7.9	-57.0

• Horizontally Polarized

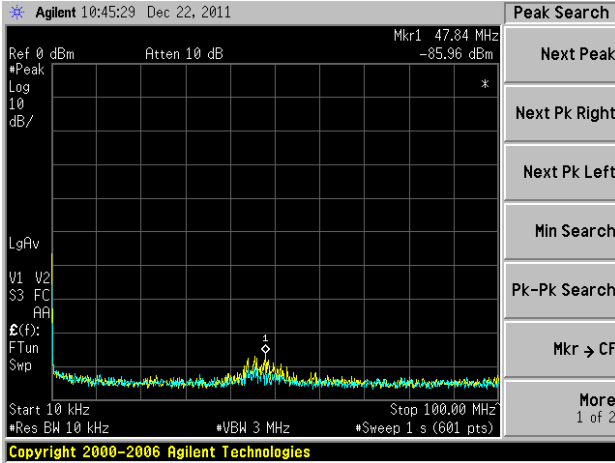

10kHz to 100MHz

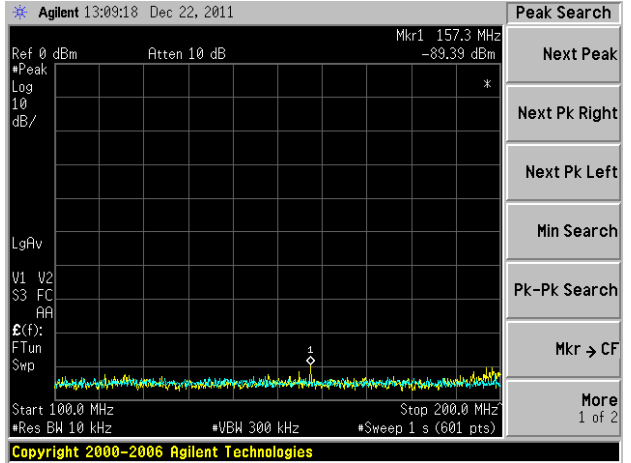

100MHz to 200MHz

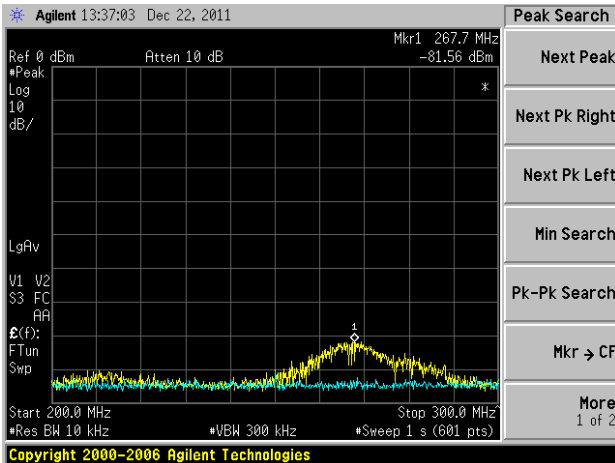

200MHz to 300MHz

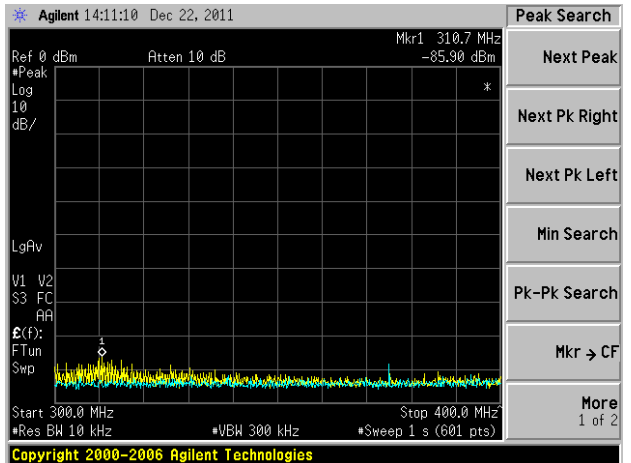

300MHz to 400MHz

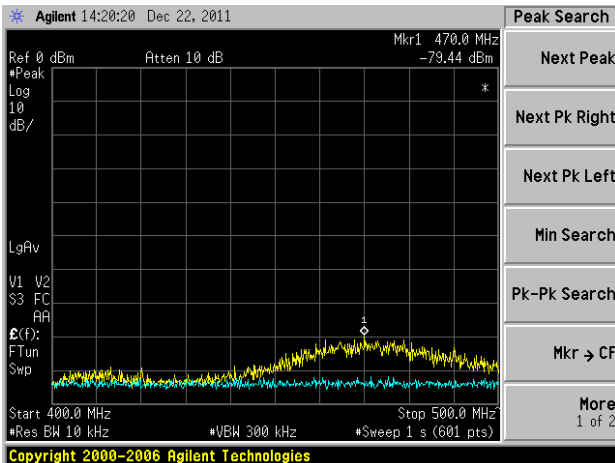

400MHz to 500MHz

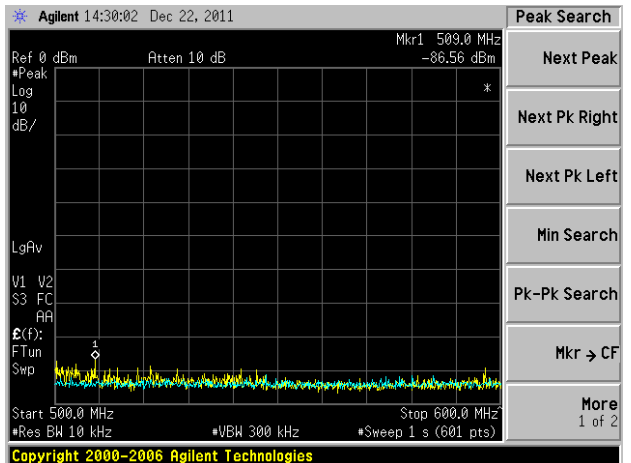

500MHz to 600MHz

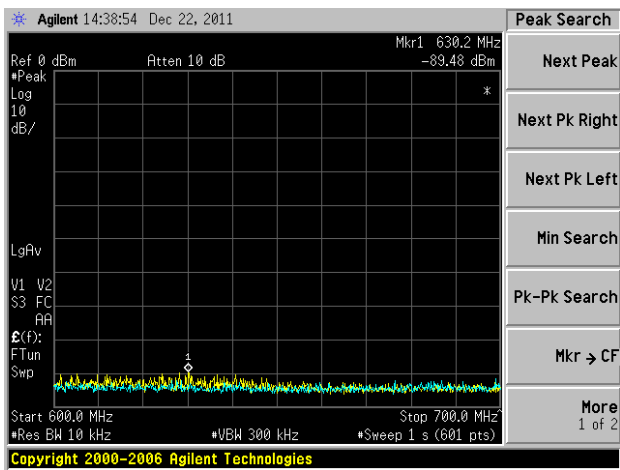

600MHz to 700MHz

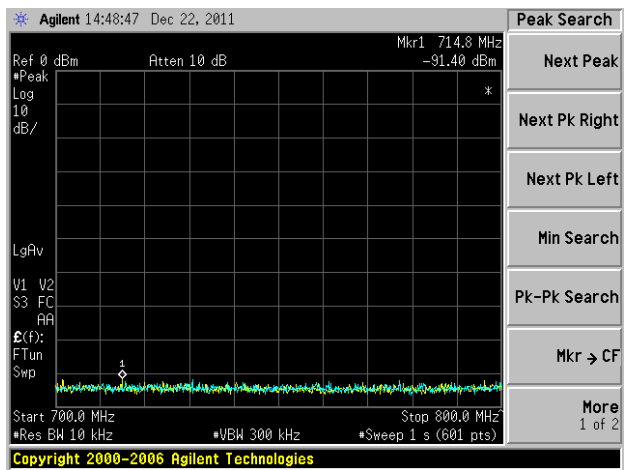

700MHz to 800MHz

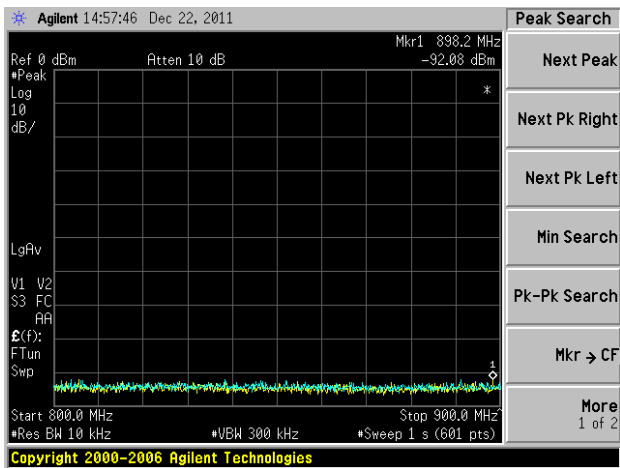

800MHz to 900MHz

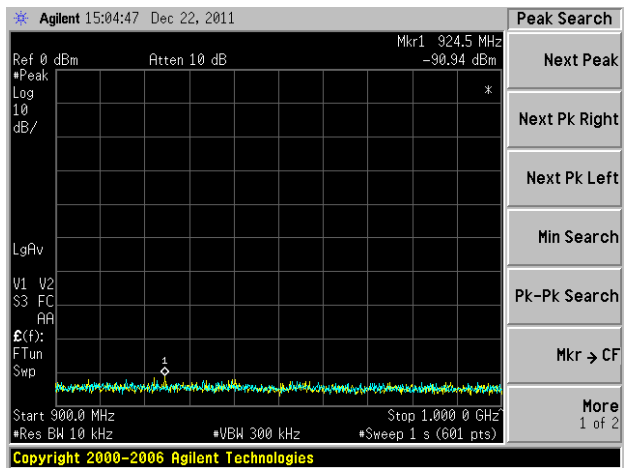

900MHz to 1GHz

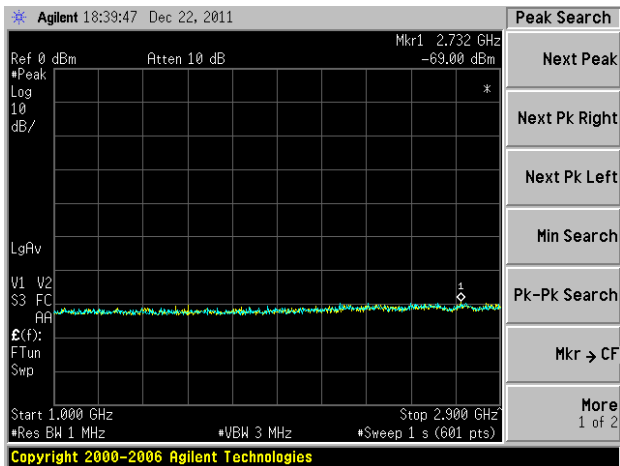

1GHz to 2.9GHz

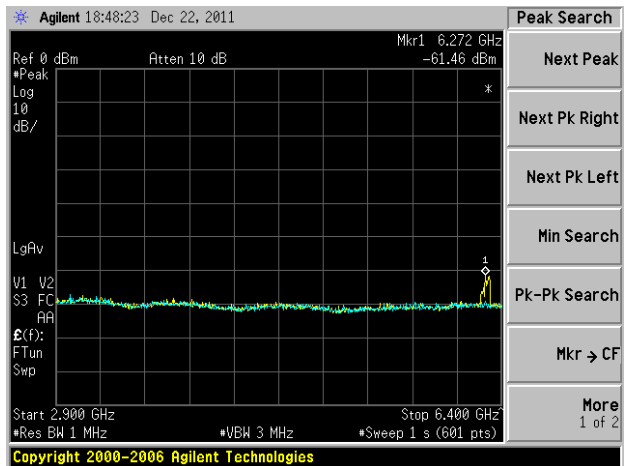

2.9GHz to 6.4GHz

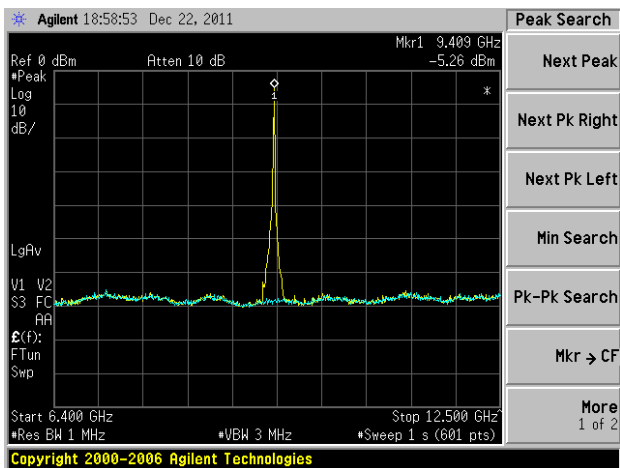

6.4GHz to 12.5GHz

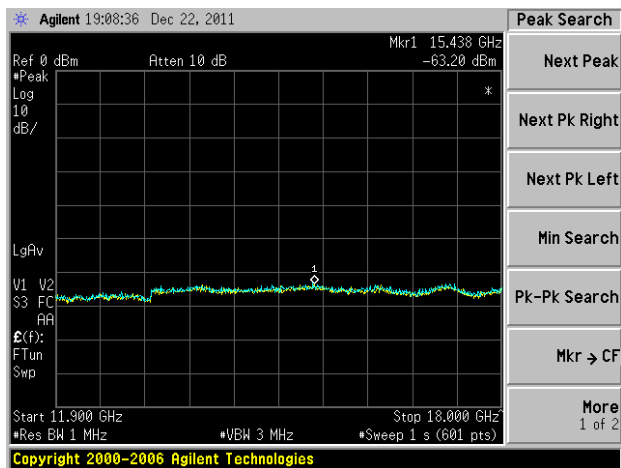

11.9GHz to 18GHz

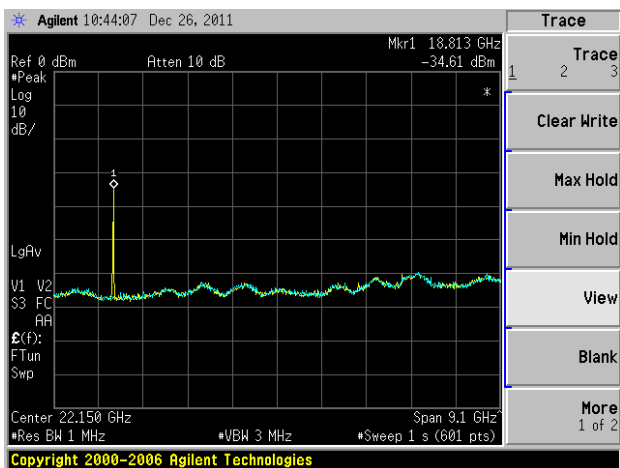

17.6GHz to 26.7GHz

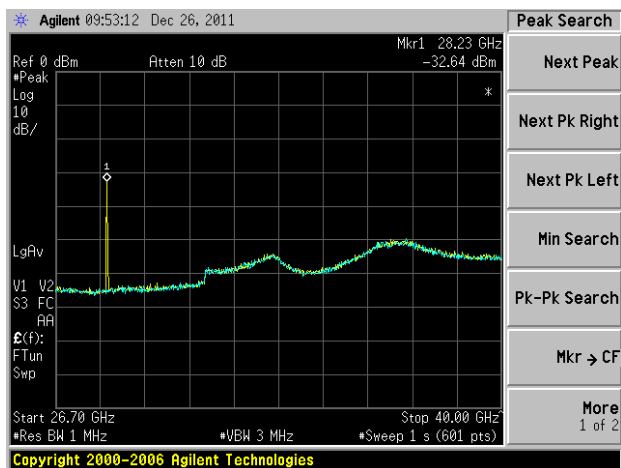

26.7GHz to 40.0GHz

·Vertically Polarized

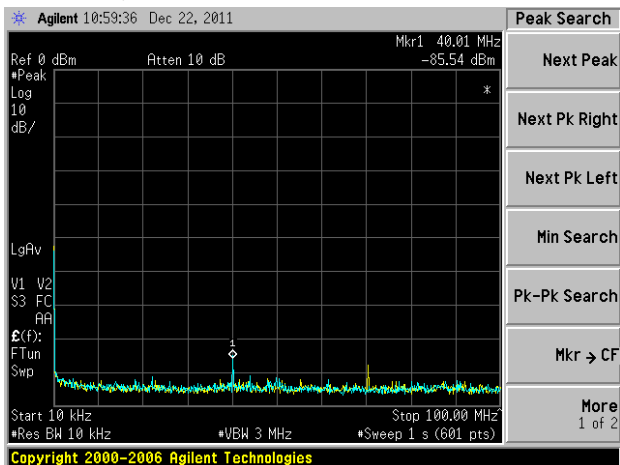

10kHz to 100MHz

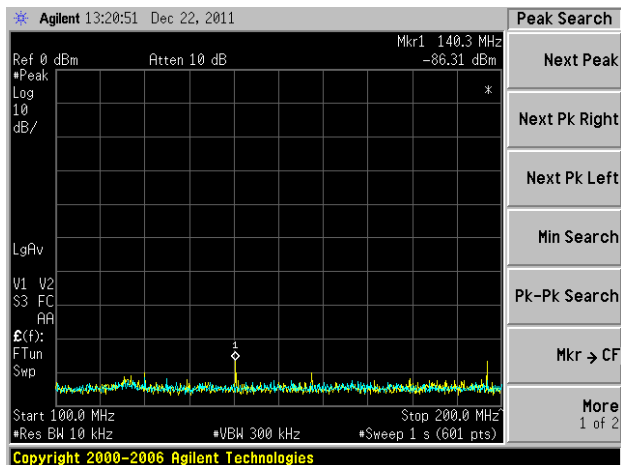

100MHz to 200MHz

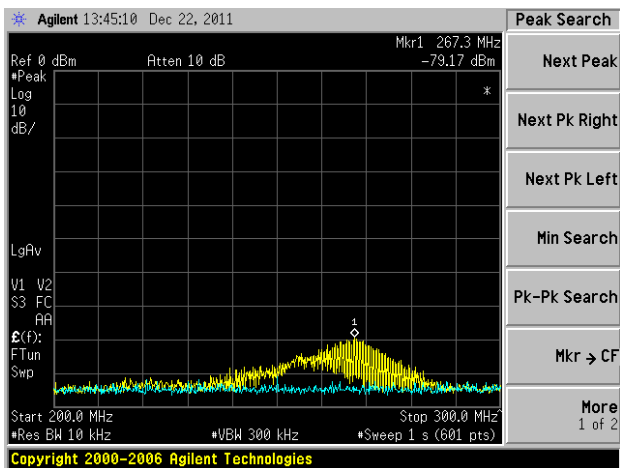

200MHz to 300MHz

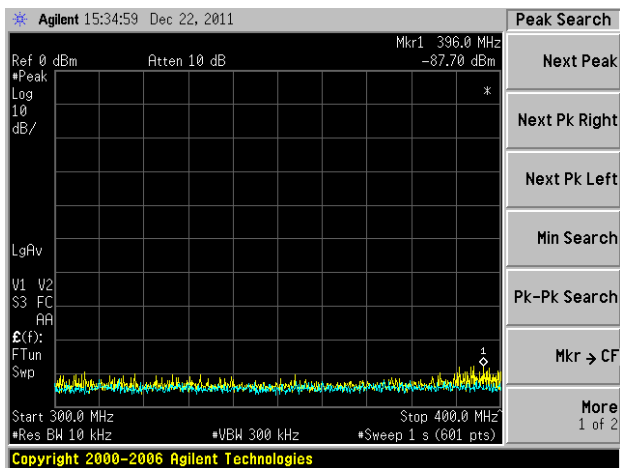

300MHz to 400MHz

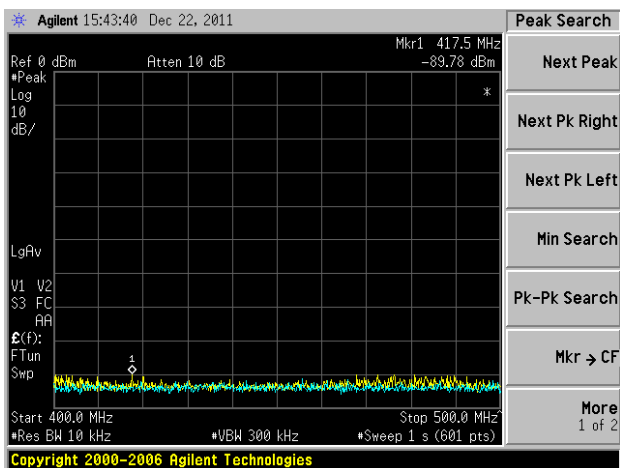

400MHz to 500MHz

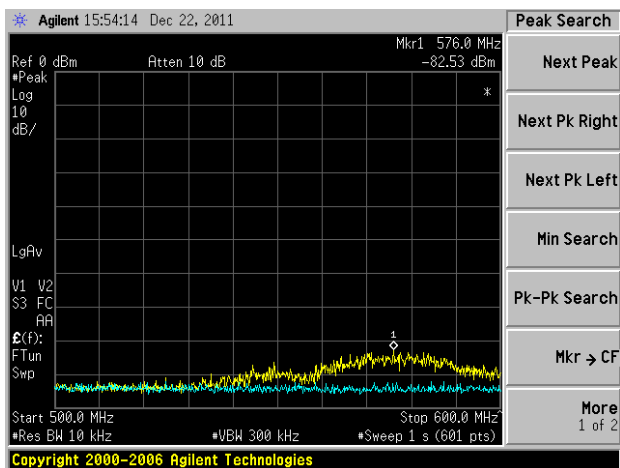

500MHz to 600MHz

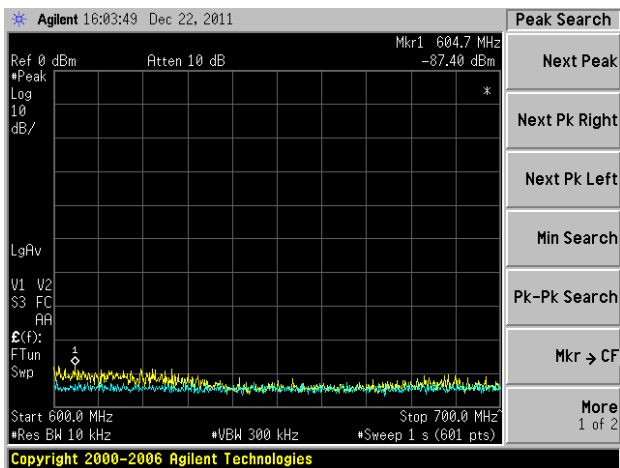

600MHz to 700MHz

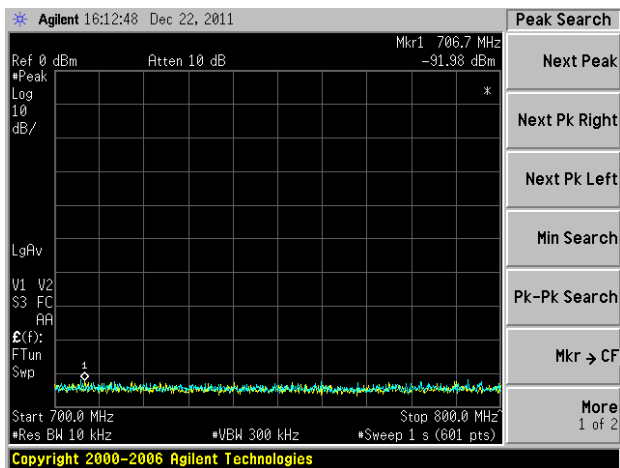

700MHz to 800MHz

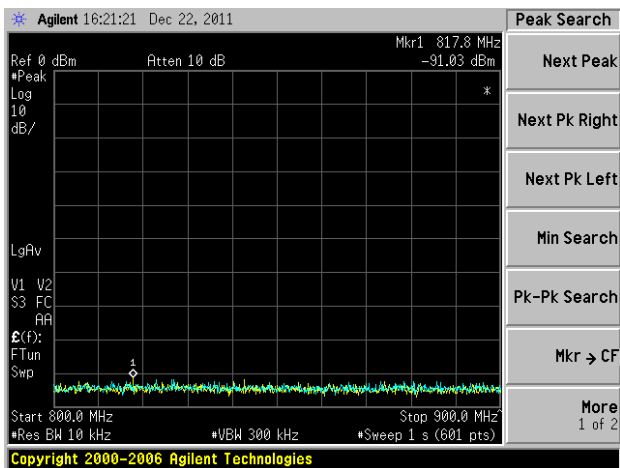

800MHz to 900MHz

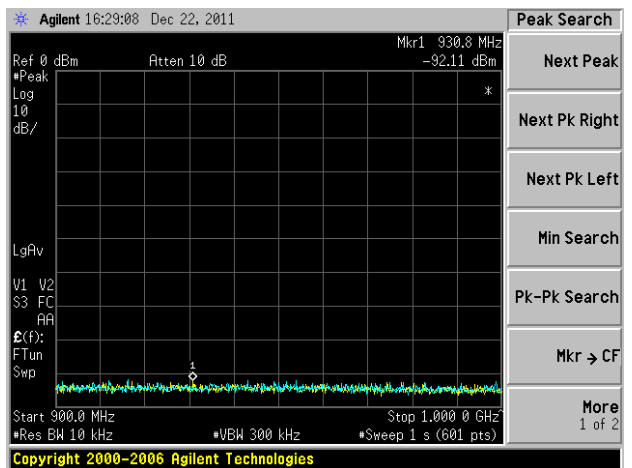

900MHz to 1GHz

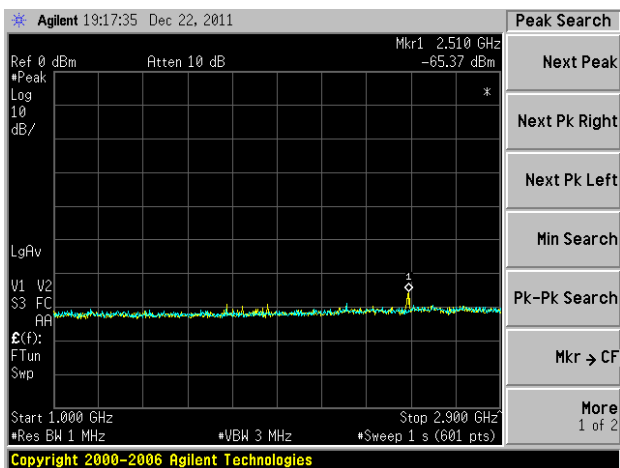

1GHz to 2.9GHz

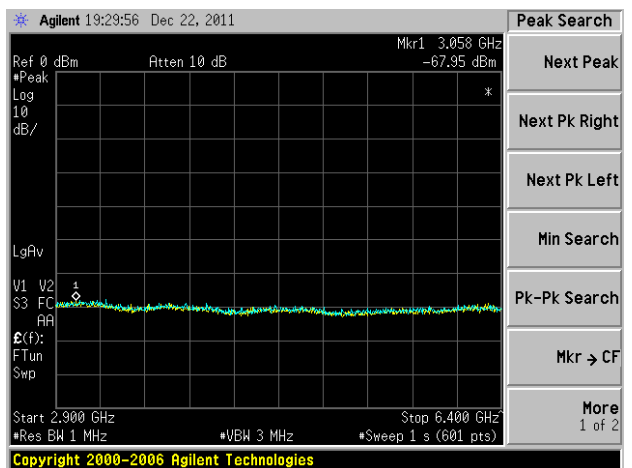

2.9GHz 6.4GHz

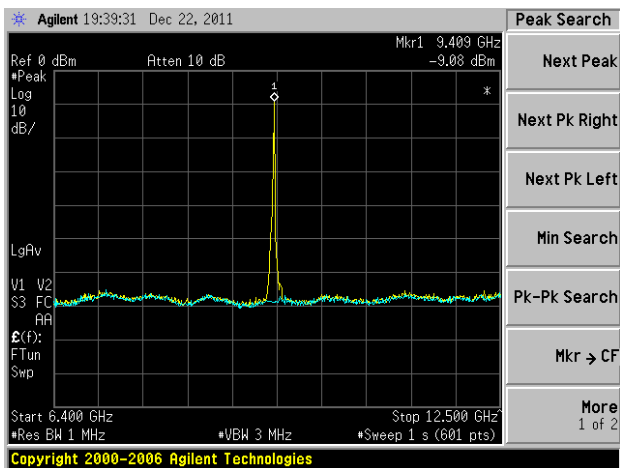

6.4GHz to 12.5GHz

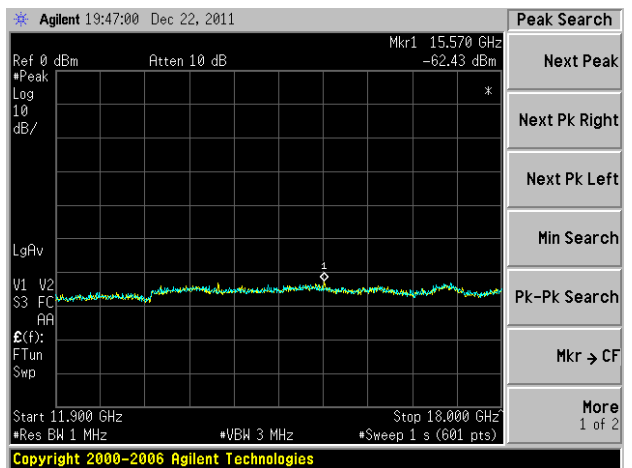

11.9GHz to 18.0GHz

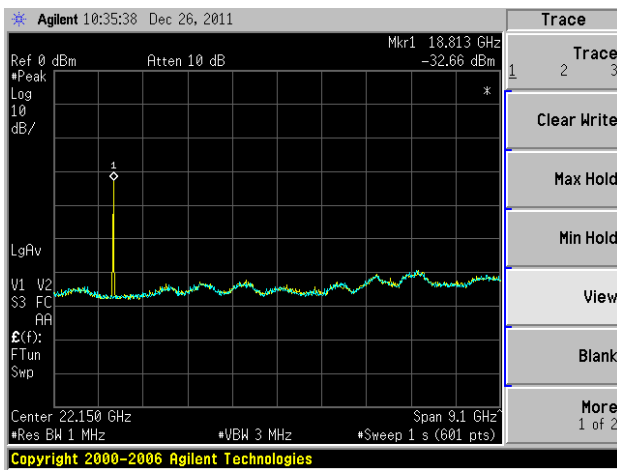

17.6GHz to 26.7GHz

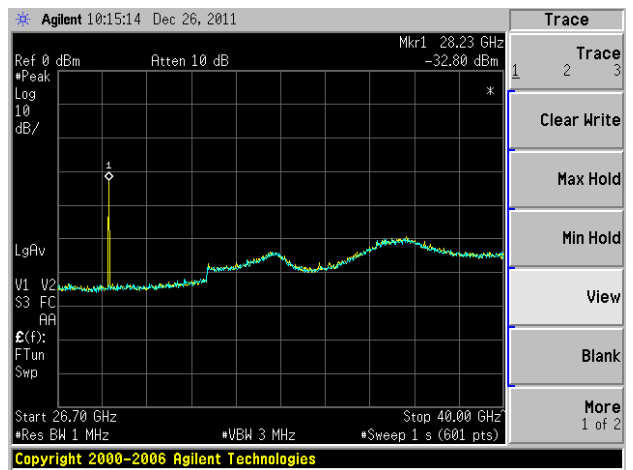

26.7GHz to 40GHz

$$P_d \text{ (dBm)} = P_g \text{ (dBm)} - \text{Cable Loss (dB)} + \text{antenna gain (dB)}$$

where:

P_g is the generator output power into the substitution antenna.

P_d is the dipole equivalent power

and radiated spurious emissions can be calculated by the following:

$$\text{Radiated spurious emissions (dBc)} = - \left[10 \log \left(\frac{TX \text{ power in watts}}{0.001} \right) - P_d \text{ (dBm)} \right]$$

4.4 Radiofrequency radiation exposure limits.

47 CFR sec. 1.1310

Power density = 0.63 [mW/cm²] is satisfied about 5 [mW/cm²].

Frequency range [MHz]	Electric field strength [V/m]	Magnetic field strength [A/m]	Power density [mW/cm ²]	Averaging time [minutes]
1500 – 100,000	48.7	0.13	0.63	6

Calculated by prediction method refer to OET Bulletin 65 as follows:

$$\begin{aligned}
 \text{Power density} \quad S_{\text{limit}} &= \frac{PG}{4\pi R^2} \\
 &= \frac{2600 * 250}{4 * \pi * 702^2} \\
 &= 0.105 \text{ [mW / cm}^2\text{]}
 \end{aligned}$$

where: P = 5000mW (power input to antenna)
 G = 10^(dB/10) = 10^(24.0/10) = 250 (power gain of the antenna)
 R = 2803cm (distance to the center of radiation of antenna)

Distance to the center of radiation of antenna

$$\begin{aligned}
 R &= \frac{0.6D^2}{\lambda} \\
 &= \frac{0.6 * 61.0^2}{3.18} \\
 &= 702
 \end{aligned}$$

where: D = 61.0cm (antenna diameter)
 λ = 3.18cm (wavelength) f = 9410MHz

Power density level(s) during the appropriate time-averaging interval

$$\begin{aligned}
 \sum S_{\text{exp}} t_{\text{exp}} &= S_{\text{limit}} t_{\text{ave}} \\
 &= 0.105 * 6 \\
 &= 0.63
 \end{aligned}$$

Electric field strength

$$\begin{aligned}
 E &= \sqrt{S * 3770} \\
 &= \sqrt{0.63 * 3770} \\
 &= 48.7 \text{ [V/m]}
 \end{aligned}$$

Magnetic field strength

$$\begin{aligned}
 H &= \sqrt{\frac{S}{37.7}} \\
 &= \sqrt{\frac{0.63}{37.7}} \\
 &= 0.13 \text{ [A/m]}
 \end{aligned}$$