

JMA-5104/5106/5110

**MARINE RADAR
EQUIPMENT**

**INSTRUCTION
MANUAL**

—ABOUT YOUR SAFETY—

Cautions for high voltage

High voltages from hundreds volts to tens of thousands volts are to be applied to the electronic equipment such radio and radar devices. You do not face any danger during normal operation, but sufficient cares are required for maintenance, inspection and adjustment of their internal components. (Authorized maintenance personnel alone are permitted to implement maintenance, check-ups or adjustment of internal components.)

High voltages of tens of thousands volts are so dangerous as to bring an instantaneous death from electric shock, but even voltages of hundreds volts may sometimes lead to a death from electric shock. To prevent such an accident, make it a rule to turn off the power button, discharge capacitors with a wire surely earthed on an end and make sure that internal parts are no longer charged before you touch any parts inside these devices. At the time, wearing dry cotton gloves ensures you further to prevent such danger. It is also a necessary caution to put one of your hands in the pocket and not to use your both hands at the same time.

It is also important to select a stable foothold always to prevent additional injuries once you were shocked by electricity. If you were injured from electric shock, disinfect the burn sufficiently and get it taken care of promptly.

What to do in case of electric shock

When finding a victim of electric shock, turn off the power source and earth the circuit immediately. If it is impossible to turn off the circuit, move the victim away promptly using insulators such as dry wood plate and cloth without touching the victim directly.

In case of electric shock, breathing may stop suddenly if current flows to the respiration center in the brain. If the shock is not so strong, artificial respiration may recover breathing. When shocked by electricity, the victim will come to look very bad with weak pulse or without beating, resulting in unconsciousness and rigidity.

FIRST AID TREATMENTS

☆ First-aid treatments

As far as the victim of electric shock is not in dangerous condition, do not move him and practice artificial respiration on him immediately. Once started, it should be continued rhythmically.

- (1) Do not touch the victim confusedly as a result of the accident, but the rescuer may also get an electric shock.
- (2) Turn off the power source calmly and certainly and move the victim away quietly from the electric line.
- (3) Call a physician or ambulance immediately or ask someone to call a doctor.
- (4) Lay the victim on his back and loosen his necktie, clothes, belt, etc.
- (5)
 - a. Examine the victim's pulse.
 - b. Examine his heartbeat bringing your ear close to his heart.
 - c. Examine his breathing bringing the back of your hand or your face close
 - d. Check the size of the pupils of his eyes
- (6) Open the victim's mouth and take out artificial teeth, cigarette or chewing gum if any. Keep his mouth open, stretch his tongue and insert a towel or the like in his mouth to prevent the tongue from suffocating. (If it is hard to open his mouth due to set teeth, open it with a screwdriver and insert a towel in this mouth.)
- (7) Then, wipe his mouth so that foaming mucus does not accumulate inside.

★When pulse is beating but breathing has stopped

- (1) Tilt the victim's head back as far as this face looks back. (A pillow may be inserted under his neck.)
- (2) Push his jaw upward to open his throat wide (to spread his airway).
- (3) Pinch the victim's nostrils and take a deep breath, block his mouth completely with yours and blow into his mouth strongly. Take a deep breath again and blow into his mouth. Continue this 10 to 15 times a minute (blocking his nostrils).
- (4) Carefully watch that he has recovered his natural breathing and stop practicing artificial respiration.
- (5) If it is difficult to open the victim's mouth, insert a rubber or vinyl tube into one of his nostrils and blow into it blocking the other nostril and his mouth completely.
- (6) When the victim recovers consciousness, he may try to stand up suddenly, but let him lie calmly and serve him with a cup of hot coffee or tea to keep him warm and quiet. (Never give him alcoholic drinks.)

Method of mouth-to-mouth respiration by raising head

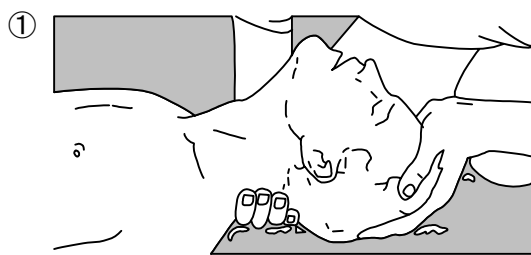

- (1) Raise the victim's head. Support his forehead with one of your hand and his neck with the other hand. → ①
When you tilt his head backward, the victim, in most cases, opens his mouth to the air. This makes mouth-to-mouth respiration easy.

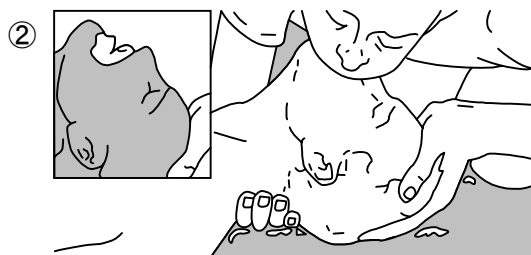

- (2) Cover his mouth as widely as possible with yours and press your cheek against his nose → ②, or, pinch his nostrils with your fingers to prevent air from leaking. → ③

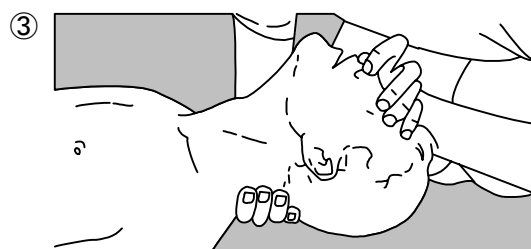

- (3) Blow into his lungs.
Continue blowing into his mouth until his breast swells. Blow into his mouth as quickly as possible for the first 10 times.

Fig.1 Mouth-to-mouth respiration

★When both pulse and breathing have stopped

When no pulse has come not to be felt, his pupils are open and no heartbeat is heard, cardiac arrest is supposed to have occurred and artificial respiration must be performed.

- (1) Place your both hands, one hand on the other, on the lower one third area of his breastbone and compress his breast with your elbows applying your weight on his breast so that it is dented about 2cm (repeat compressing his breast 50 times or so a minute).

(Cardiac massage)

- (2) **In case of one rescuer,**

Repeat cardiac massages about 15 times and blow into his mouth 2 times quickly, and repeat this combination.

In case of two rescuers,

One person repeats cardiac massages 15 times while the other person blows into his mouth twice, and they shall repeat this combination.

(Cardiac massage and mouth-to-mouth respiration)

- (3) Examine his pupils and his pulse sometimes. When the both have returned to normal, stop the artificial respiration, serve him with a cup of coffee or tea and keep him warm and calm while watching him carefully. Commit the victim to a medial specialist depending on his condition. To let him recover from the mental shock, it is necessary for persons concerned to understand his situations and the necessary treatments.

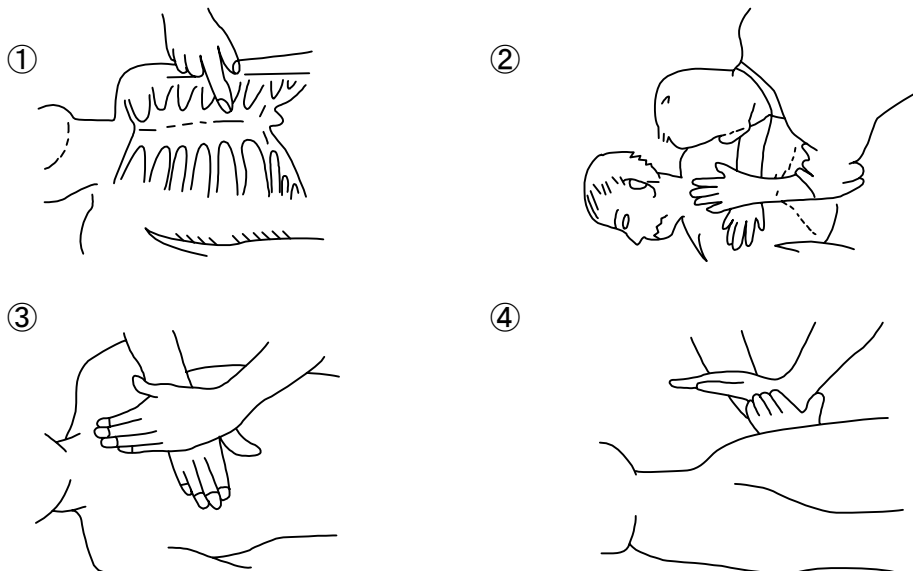

Fig.2 Cardiac massage

PREFACE

Thank you very much for purchasing the JRC marine radar equipment, JMA-5104, JMA-5106 and JMA-5110.

This equipment is a marine radar equipment designed to obtain safe operation of marine ships. The equipment consists of a radar signal transceiver unit, a LCD display unit and a scanner unit as its main units.

- Before operating the equipment, be sure to read this instruction manual carefully for correct operation.
- Maintain this instruction manual so that operators can refer to it at anytime.

Refer to this manual when any inconvenience or defect occur.

● Before Operation ●

Pictorial Indication

Various pictorial indications are included in this manual and are shown on these equipment so that you can operate them safely and correctly and prevent any danger to you and / or to other persons and any damage to your property during operation. Such indications and their meanings are as follows.

Please understand them before you read this manual:



This indication is shown where any person is possibility to be in danger of being killed or seriously injured, if this indication is neglected and these equipment are not operated correctly.



This indication is shown where any person is supposed to be in danger of being killed or seriously injured if this indication is neglected and these equipment are not operated correctly.



This indication is shown where any person is supposed to be injured or any property damage is supposed to occur if this indication is neglected and these equipment are not operated correctly.

Examples of pictorial indication



Electric Shock

The△mark represents CAUTION (including DANGER and WARNING).

Detailed contents of CAUTION ("Electric Shock" in the example on the left.) is shown in the mark.



Disassembling Prohibited



Prohibition

The⊘mark represents prohibition.

Detailed contents of the prohibited action ("Disassembling Prohibited" in the example on the left) is shown in the mark.



Disconnect the power plug



instruction

The●mark represents instruction.

Detailed contents of the instruction ("Disconnect the power plug" in the example on the left) is shown in the mark.

Warning label

There is a warning label on the top cover of the equipment.

Do not try to remove, break or modify the label.

●Cautions to be used during operation●

DANGER



The customer should refrain from inspecting or repairing the internal parts of this equipment.

Inspection or repair other than by specialized service personnel may cause death or a serious injury of any person.

Please contact the sales department of Japan Radio Co., Ltd. or your local branch, outlet or sales office with respect to maintenance and repair.



When performing maintenance in increment weather, please be sure to shut the main power off.

Maintenance work performed without shutting the main power off may cause death or a serious injury of any person by electric shock.



When performing maintenance or inspection of the scanner unit, be sure to shut off the main power source.

Sudden movement of the scanner may cause death or a serious injury of any person.



Be sure to shut off the main power source when approaching the scanner unit for the purposes of maintenance or inspection.

Exposure to electric waves at proximate distances may cause death or a serious injury of any person.



High Voltage

Since some sections of the modulator (CME-322 or QME-323) generate a high voltage of about 4000V, no one except service engineers are allowed to touch inside of the modulator.

The high voltage may cause death or a serious injury of any person by electric shock.



When the above setting is set to OFF, microwaves are radiated even if the scanner unit is not rotating, it may cause death or a serious injury of any person. Therefore, utmost care is necessary.

Make the setting is set ON after the required operation is completed.

DANGER



Make sure that the main power is turned off before maintaining the equipment.

In particular, when a rectifier is used, a voltage is output from the rectifier even if the power of the display is turned off and the radar is stopped.

This may cause failures of equipments, or death or a serious injury of any person by electric shock.



When checking a scanner unit for maintenance, make sure that the main power is turned off and the safety switch attached to the scanner unit is set to OFF.

If the power is not turned off, failures of equipments may occur, and death or a serious injury of any person may occur by electric shock.

And touching a rotating scanner unit may cause failures of equipments, or death or a serious injury of any person by electric shock.

WARNING



Do not touch the insides of the scanner unit, transceiver and display unit. Touching any high voltage area, you will get an electric shock. For maintenance, inspection and adjustment of internal parts of these equipment, consult with our sales office or distributor in your district.



Since the scanner unit radiator rotates, do not approach it. The scanner unit may start rotating suddenly, and consequently any person may be struck and be injured. We recommend you to install the scanner unit radiator on the roof of the wheel house, flying bridge, trestle, radar mast or any other high position so that no person can approach it. When servicing the scanner unit, set the scanner unit safety button to the OFF position.



Install the scanner unit at any place higher than any person. If being exposed directly to electric wave at close range, you may suffer adverse influence.



When approaching the antenna for maintenance or inspection, set the power button of the display unit to the ST-BY position. If being exposed directly to electric wave at close range, you may suffer adverse influence.



Before starting maintenance work or the like, stop power supply by turning off the power and disconnecting the power connector from the rectifier and the display. Even if the power switch is turned off, there are live components in each unit. In this status, maintenance or inspection work causes an electric shock, system failure, or accident.



Before disposing of used lithium batteries, insulate by affixing tape to the positive and negative terminals or by other means. Otherwise, short-circuiting may occur, resulting in heat generation, bursting or ignition.



Only specialized personnel shall perform installation work. Installation work performed by personnel other than specialized personnel may cause breakdown of the equipment, poor performance, fire, severe electric shock and other property and human damages.

WARNING



This adjustment is a function of adjusting tune indication and peak of echo, it is already made at the factory.

The default value is 64.

The settings must not be changed on the spot.

When the tune indication and peak of echo shift, if the settings are carefully adjusted, you can not get the tuning.

The gain falls, a collision etc. may occur.



Do not change this adjustment unnecessarily.

An incorrect adjustment may erase the closest target and a collision occurs, this may cause death or a serious injury of any person.

CAUTION



Use these radar only as assisting devices for navigation.
Also, the officer should make the final decision for maneuvering by himself.
If you make the final decision of maneuvering only on the information which a radar display, it may become the cause of accidents, such as collision and stranding.



Do not set the rain/snow clutter function to too high a suppression level.
Otherwise, not only echoes from rain/snow but also the targets of ships or dangerous objects are suppressed, which may disturb the detection.
Set the best suppression level whenever you use the rain/snow clutter suppression function.



Do not set the sea clutter suppression function to a level at which it clears all sea clutters in short range.
Otherwise, not only echoes from waves but also the targets of ships or dangerous objects are suppressed, which may disturb the detection.
Set the best suppression level whenever you use the sea clutter suppression function.



The scanner unit shall be installed where there are not large obstacles in the direction of the ship's heading line in the same plane.
If there is a large impediment in the same plane as the scanner unit, this may cause the generation of false echoes. In particular, if such false echoes appear at the ship's heading line, monitoring will be difficult and this may cause inadequate forecasting of danger.



Do not install the scanner unit near chimney's or the exhaust of chimneys.
Soot will cause the performance of the radar to decrease and heat may cause breakdown.



Do not install direction antenna or VHF antenna in the vicinity of the scanner unit. Doing so may cause noise in the antenna reception.



Consideration should be given to separating the radar cable from the cables for the direction antenna and VHF antenna.
These cables should never be bundled into one. Doing so may cause noise in the antenna reception.

CAUTION



If felt is not provided where the rope contacts the scanner, or if the scanner is supported near the both ends of the radiator, you may damage the unit.
Be sure to apply the rope to the antenna support.



When mounting the scanner unit, please check the maximum length of the holding bolts.
If the bolts are too long, it gives severe damage to inside of the scanner.
When mounting the scanner unit, please use the attached bolts.
The mounting base thickness must not exceed 15mm (0.6inch).



Provide a distance of 1m or more between a processing unit and a magnetic compass.
If a processing unit is installed in a position too close to a magnetic compass, it may affect the magnetic compass.



Install a processing unit in the location that is not affected by seawater.
The processing unit is not waterproof.



Use correct fuse ratings.
The use of incorrect ratings may cause an equipment failure.



The GPS compass JLR-10 of JRC always can output absolute azimuth without gyro setting.
Therefore, do not set a gyro value when connecting JLR-10.



Since the modulation section contains a magnetron with stored magnetism, do not place a lock or a magnetic card close to the modulation section.
Otherwise, failures or data corruption may occur in such devices.



Do not use solvents such as thinner, gasoline, benzene, trichlene, and ketone.
These solvents cause discoloration or deterioration.

EQUIPMENT APPEARANCE



Scanner Unit Type NKE-2042 (2 feet)



Scanner Unit Type NKE-2062 (4 feet)



Scanner Unit Type NKE-2102 (6 feet)



Processing Unit Type NDC-1260



Display Unit Type NWZ-146 (Landscape) and Keyboard Unit NCE-7640



Display Unit Type NWZ-146 (Portrait) and Keyboard Unit NCE-7640

Contents

PREFACE	I
Before Operation	II
Cautions to be used during operation	III
EQUIPMENT APPEARANCE	IX
Chapter 1 Introduction	1
1.1 Functions	1
1.2 Features	1
1.3 Composition	2
1.4 Configuration	4
1.5 General System Diagram	11
Chapter 2 Names and Functions in the Keyboard Unit and the Menu Structure ..	14
2.1 Functions of the Keyboard	14
2.1.1 Outline of the keyboard functions	14
2.1.2 Configuration and functions of the keys on keyboard	16
2.1.3 Structure and the functions of knobs	19
2.1.4 Structure and functions of the jog dial	20
2.1.5 Structure and functions of the track ball	20
2.2 Description of Screen Display	21
2.3 Menu Functions	23
2.3.1 Menu structure	23
General menu [MENU] (1/1 page)	24
Installation setting menu [MENU] (1/3 pages)	25
Installation setting menu [MENU] (2/3 pages)	26
Installation setting menu [MENU] (3/3 pages)	27
Menu by a direct key [TRAILS] (1/1 page)	28
Menu by a direct key [DIMM]	29
Menu by a direct key [ALARM ACK]	30
Menu by a direct key [ATA] (1/3 pages)	31
Menu by a direct key [ATA] (2/3 pages)	32
Menu by a direct key [ATA] (3/3 pages)	33
Menu initialization by pressing a key at Power ON	34
Setting menu language by pressing a key at Power ON	34
Chapter 3 Operation Procedures	35
3.1 Operation Flow	35
3.2 Power-on Operation	36
3.2.1 Power-on and start	36

1.	Turning on the power [STBY].....	36
2.	Transmitting [TX/PRF].....	36
3.2.2	Tuning [AUTO-TUNE].....	36
1.	Switching the tuning mode.....	36
2.	Turning the tuning control [AUTO-TUNE].....	36
3.2.3	Observation and image adjustment [+RANGE-].....	36
3.2.4	Data acquisition and measuring.....	36
3.2.5	Operation termination and stop [STBY], [TX/PRF].....	37
1.	Canceling transmission [STBY].....	37
2.	Turning off the power.....	37
3.3	Preparation for Observation.....	38
3.3.1	Changing the brightness of the LCD.....	38
3.3.2	Changing the brightness of the keyboard [DIMM].....	38
3.3.3	Switching the display language [DIMM].....	38
3.3.4	Setting the volume of the buzzer [ALARM ACK].....	39
3.3.5	Switching the day/night mode [DIMM].....	40
1.	Switching the day/night mode [DIMM].....	40
2.	Switching the display color [DIMM].....	40
3.	Switching the brightness of the screen [DIMM].....	41
3.4	Basic Operation.....	43
3.4.1	Transmitting [TX/PRF].....	43
3.4.2	Halting transmission [STBY].....	43
3.4.3	Changing the range [+RANGE-].....	43
3.4.4	Erasing/displaying the fixed range marker [RR/HL].....	43
3.4.5	Erasing the ship's heading marker [RR/HL].....	43
3.4.6	Tuning.....	43
3.4.7	Adjusting sensitivity [GAIN/PL].....	43
3.5	General Operation.....	44
3.5.1	Eliminating radar interference [MENU].....	44
3.5.2	When it is raining or snowing [AUTO-RAIN].....	45
3.5.3	When the sea is rough [AUTO-SEA].....	46
3.5.4	Using the trackball [TRACK BALL].....	47
3.5.5	Using VRM [VRM1/VRM2], [JOG DIAL].....	48
1.	Selecting VRM#1/VRM#2 [VRM1/VRM2].....	48
2.	Operating VRM#1/VRM#2 [VRM1/VRM2].....	48
3.	Erasing VRM#1/VRM#2 [VRM1/VRM2].....	48
4.	Measuring the distance from own ship using VRM#1 [VRM1/VRM2].....	49
5.	Measuring the distance from own ship using VRM#2 [VRM1/VRM2].....	49
6.	Setting KM as range units.....	50
3.5.6	Using EBL (electronic bearing cursor) [EBL1/EBL2], [TRACK BALL].....	51
1.	Selecting EBL#1/EBL#2 [EBL1/EBL2].....	51
2.	Operating EBL#1/EBL#2 [EBL1/EBL2].....	51
3.	Erasing EBL#1/EBL#2 [EBL].....	51
4.	Measuring the bearing from own ship using EBL#1 [EBL1/EBL2].....	52
5.	Measuring the bearing from own ship using EBL#2 [EBL1/EBL2].....	52

6.	Using EBL2 as a floating EBL.....	52
7.	Setting EBL display.....	53
3.5.7	Changing the bearing presentation method of the PPI screen [AZI MODE].....	54
3.5.8	Changing the center of the PPI screen [OFFCENT].....	55
	1. Setting a position to which the center is moved.....	55
	2. Canceling the position as the new center.....	55
	3. Continuously moving the center.....	56
	4. Canceling the position as the new center.....	56
3.5.9	Using the trail display function [TRAILS].....	56
	1. Setting the trail display function to ON/OFF [TRAILS].....	56
	2. Setting a trail interval [TRAILS].....	57
	3. Clearing stored trail data [TRAILS].....	57
	4. Setting a trail reference level (trail threshold) [TRAILS].....	57
	5. Setting a trail storage suppression distance [TRAILS].....	58
	6. Setting a range trail storage [TRAILS].....	58
3.5.10	Using the target expansion function [MENU].....	59
	1. Setting the target expansion function.....	59
	2. Canceling the target expansion function.....	59
3.5.11	Changing the transmitter pulse length [GAIN/PL].....	59
	Changing the pulse length.....	60
3.5.12	Using the zoom function [MENU].....	60
	1. Setting the zoom function.....	60
	2. Canceling the zoom function.....	60
3.5.13	Highlighting a target by decreasing unnecessary noise (image processing) [MENU].....	61
	1. Setting image processing [MENU].....	61
	2. Canceling image processing [MENU].....	62
	3. Setting an image processing range [MENU].....	62
3.5.14	Switching true/relative motion display [TM/RM].....	63
	1. Switching the motion mode.....	63
	2. Resetting own ship's position in true motion display (TM).....	63
3.5.15	Suppressing the power consumption of the radar [MENU].....	65
	1. Using the intermittent transmitting function [MENU].....	65
	2. Canceling the intermittent transmitting function [MENU].....	65
	3. Setting the period of the transmitting state (the number of antenna rotations) [MENU].....	65
	4. Setting the period of the standby state [MENU].....	66
3.5.16	Monitoring the heading of other ships (targets) [ALARM ACK].....	67
	1. Using the radar alarm [ALARM ACK].....	67
	2. Canceling the radar alarm function.....	67
	3. Creating a radar guard zone [ALARM ACK].....	67
	4. Setting a radar guard zone [ALARM ACK].....	68
	5. Setting a radar guard zone detection level [ALARM ACK].....	68
3.5.17	Resetting an alarm (stopping a warning) [ALARM ACK].....	69
3.5.18	Displaying parallel line cursors [MENU], [VRM], [EBL].....	69
3.5.19	Using the MOB function [MOB].....	70
	1. Displaying the MOB mark.....	70

2.	Erasing the MOB mark	70
3.5.20	Using the WAYPOINT function [MENU]	71
1.	Displaying WAYPOINT	71
2.	Erasing WAYPOINT.....	71
3.5.21	Own ship display function [MENU].....	72
Switching own ship display.....		72
3.5.22	Function to convert time difference display to latitude/longitude display [MENU]	72
1.	Setting the LORAN chain (base station number)	72
2.	Setting time difference (TD1 or TD2).....	73
3.	Setting the correction value (of TD1 or TD2)	73
3.5.23	Cursor/own-ship position output function [CSR POS]	73
3.6	Use of Function Keys	75
3.6.1	Overview	75
3.6.2	Operation procedures	76
1.	Calling a function.....	76
2.	Changing the setting of a function key	76
3.	Changing a function key title	76
4.	Initializing the setting of a function key (Returning to the factory setting).....	77
Function key menu lists (display only)		78
3.7	Other Procedures Required.....	79
3.7.1	Confirming software versions [MENU].....	79
3.7.2	Confirming the operating status of connected units [MENU]	79
3.7.3	Displaying magnetron current [MENU] [+RANGE-].....	80
3.7.4	Confirming error logs [ALARM ACK]	81
3.7.5	Clearing the error log [ALARM ACK]	82
3.7.6	Operating the self-diagnostic function [MENU]	82
3.7.7	Displaying the help menu	82
3.7.8	Replacing the battery (BT1).....	83
3.7.9	Procedure if an incomprehensible symptom occurs during use of the radar	84

Chapter 4 How to Interpret the PPI Screen 85

4.1	Height of and the Distance to the Target.....	85
Distance and Target		85
4.2	Returns from a Target.....	86
4.3	Propagation Path of Radio Waves	86
4.3.1	Sea returns	87
4.3.2	False echoes	87
4.4	Display of Radar Transponder	89

Chapter 5 Maintenance and Inspection 90

5.1	General Maintenance	90
5.2	Scanner Unit	91
5.3	Display Unit	91

5.4	Special Parts	92
5.5	Circuit Blocks for Repair	93
5.6	Actions to Deal with Abnormalities and Breakdown	94
 Chapter 6 After-sales Service		95
	When asking for repair	95
	Recommendation of maintenance inspection	95
	RADAR FAILURE CHECKLIST	96
 Chapter 7 Disposal		97
7.1	Equipment Disposal	97
7.2	Disposal of Used Batteries	97
7.3	Disposal of Used Magnetron	97
 Chapter 8 Specifications		98
8.1	General Specifications	98
8.2	Scanner Unit Specification	99
	8.2.1 Scanner unit (NKE-2042 : Redome type)	99
	8.2.2 Scanner unit (NKE-2062 : 6kW rotation type)	99
	8.2.3 Scanner unit (NKE-2102 : 10kW rotation type)	100
8.3	Processing Unit Specifications	101
8.4	Keyboard Unit Specifications	103
8.5	Display Unit Specifications	104
8.6	Option	105
	8.6.1 Interunit cable	105
	8.6.2 Rectifier unit	105
	8.6.3 Flash mounting kit	105
	8.6.4 MARPA	105
	8.6.5 NSK unit	105
	8.6.6 Sub indicator unit signal out	106
	8.6.7 Sub keyboard unit	106
8.7	Rectifier	107
8.8	Cable Length between Equipment Units	107
 Chapter 9 Installation		108
This chapter has been written for the service technicians to read in case of installation.		
9.1	General	108
9.2	Installing the Scanner Unit	109
	9.2.1 Selecting the installation location	109
	9.2.2 Installation procedure	111
	1. Stand	111

	2. Suspending the Scanner	112
	3. Paint.....	112
	4. Magnetism.....	112
9.2.3	Connection of cables to be assembled.....	113
	1. Radome scanner unit (NKE-2042)	113
	2. Rotary scanner unit (NKE-2062/NKE-2102).....	115
9.3	Installing an Indicator Unit	117
9.3.1	Specifying the installation position	117
9.3.2	Installation method	117
9.3.3	Rear of the processing unit.....	118
9.3.4	Signals of option connectors	119
9.3.5	Installing and display unit.....	121
	1. Setting vertically or horizontally.....	121
	2. Connecting cables	121
9.3.6	Installing a keyboard unit	123
	Connecting a cable	123
9.3.7	Attaching a power cable (CFQ-6911-5)	124
9.3.8	Attaching a cable between a processing unit and a scanner unit (CFQ-6912-20/30)	126
9.3.9	Connecting a GPS receiver and NMEA equipment.....	128
	1. Connecting GPS receiver of JRC	128
	2. Connecting another manufacturer's GPS receiver or NMEA data output equipment	128
	3. NMEA0183 standard input/output sentences	130
9.3.10	Connecting a GPS compass (JLR-10)	131
	1. Using a dedicated cable	131
	2. When not using a dedicated cable	132
9.3.11	Connecting an electromagnetic compass	133
9.3.12	Connecting gyro	134
9.3.13	Connecting a PC plotter and NMEA equipment.....	135
	1. Outputting NMEA0183 data to a PC plotter (RS232C output).....	135
	2. Outputting NMEA0183 data to NMEA equipment (RS422 output)	135
	3. Switching RS232C/RS422 signal output.....	136
9.3.14	Connecting external buzzers.....	137
9.4	Changing Ship's Power.....	138
	1. Display	138
	2. Scanner unit	138
9.5	Checking and Adjustment After Installation	139
9.5.1	Checking after installation.....	139
9.5.2	Checking operation	139
9.5.3	Various adjustments.....	139
9.5.4	Rectifier	140
9.6	Adjustment	141
9.6.1	General adjustment.....	141
9.6.2	Adjusting a scanner unit.....	141
	1. Adjusting AVR output voltage of a modulator	141
	2. Adjusting a tuning indication level of a receiver	141

9.6.3	Adjusting an indicator unit.....	142
	Adjusting AVR output	142
9.7	Initialization.....	143
9.7.1	Adjusting a receiver [+RANGE-] [TX/PRF] [AUTO-TUNE] [MENU]	144
	1. Tuning preset	144
	2. Center frequency adjustment.....	144
	3. Tuning indicator level adjustment.....	145
9.7.2	Noise level adjustment [MENU]	146
9.7.3	Azimuth adjustment [TM/RM] [AZI MODE] [MENU].....	146
9.7.4	0 mile adjustment [TM/RM] [AZI MODE] [MENU].....	147
9.7.5	Setting a scanner unit height [MENU].....	147
9.7.6	Setting a gyro value [MENU] [AZI MODE].....	148
9.8	Various Initial Settings	149
9.8.1	Sensitivity preset [AUTO-SEA] [AUTO-RAIN] [GAIN/PL] [MENU]	149
9.8.2	Sea clutter preset [+RANGE-] [AUTO-TUNE] [AUTO-SEA] [AUTO-RAIN] [GAIN/PL] [MENU]	149
9.8.3	Control of main bang [+RANGE-] [AUTO-TUNE] [AUTO-SEA] [AUTO-RAIN] [GAIN/PL] [MENU] ...	150
9.8.4	Setting a close range dynamic range [MENU]	151
9.8.5	Setting a video gradation level [MENU]	152
9.8.6	Setting video noise suppression display [MENU]	152
9.8.7	Setting a small target detection mode [MENU]	153
9.8.8	Setting a float mode [MENU].....	154
9.8.9	Setting an inference suppression function level [MENU].....	154
9.8.10	Setting a short distance dynamic range [MENU]	155
9.8.11	Setting a value of the target expansion function [MENU].....	155
9.8.12	Setting target expansion function control [MENU]	156
9.8.13	Setting a sensitivity correction value [MENU].....	156
9.8.14	Setting transmission power control [MENU].....	157
9.8.15	Setting a scanner unit rotation speed [MENU].....	157
9.8.16	Setting information in a GPS receiver.....	158
	1. Setting the position of your own ship [MENU].....	158
	2. Setting a height of own ship [MENU].....	158
	3. Setting geodetic information [MENU]	159
	4. Setting a position fixing mode [MENU].....	160
	5. Setting a HDOP level [MENU]	160
	6. Setting an averaging level [MENU].....	161
	7. Setting a prohibited satellite number [MENU].....	161
	8. GPS receiver master reset [MENU].....	164
	9. Sending updated set values [MENU]	164
	10.Setting UTC time [MENU]	165
	11.Setting a UTC time difference [MENU].....	165
	12.Sending updated setting values [MENU]	165
9.8.17	Setting information in a DGPS receiver	167
	1. Setting a DPGS mode [MENU].....	167
	2. Setting a frequency used by a beacon station [MENU].....	167
	3. Setting a baud rate for communication with a beacon station [MENU].....	167

4.	Setting a DPGS mode [MENU].....	168
5.	Sending updated setting values [MENU]	168
9.8.18	Setting information in a WAAS receiver.....	169
1.	Setting a WAAS mode [MENU]	169
2.	Setting a position fixing satellite [MENU].....	169
3.	Setting information whether a prohibited satellite can be used [MENU]	169
4.	Setting a satellite number [MENU].....	170
5.	Sending updated setting values [MENU]	170
9.8.19	Displaying GPS receiving status	171
9.8.20	Initializing ATA [MENU]	171
9.8.21	Setting a course data input type [MENU]	172
9.8.22	Setting manual course data [MENU]	173
9.8.23	Setting a speed data input type [MENU]	173
9.8.24	Setting manual speed data [MENU]	174
9.8.25	Setting own ship's position input selection [MENU].....	174
9.8.26	Setting own ship's position input [MENU].....	175
9.8.27	Setting a compass input baud rate [MENU]	175
9.8.28	Setting connection of the 2nd keyboard [MENU].....	176
9.8.29	Setting a NMEA data output frequency [MENU].....	176
9.8.30	Setting selection of a magnetic azimuth sensor correction value [MENU].....	177
9.8.31	Setting manual data for a compass correction value [MENU]	178
9.8.32	Setting a PC output baud rate [MENU].....	178
9.8.33	Setting a keyboard port baud rate [MENU]	178
9.8.34	Setting a display direction of the indicator [MENU].....	179
9.8.35	Setting a display timing of the indicator [MENU]	179
9.8.36	Setting reading/writing setting values to non-initialization memory [MENU]	180
9.8.37	Initializing a menu storage area [MENU].....	181
9.8.38	Displaying simulator images.....	181
9.8.39	Special mode.....	182
9.9	Resetting Adjustments to the Initial State.....	183
9.10	Maintenance	184
9.10.1	General maintenance.....	184
1.	Cleaning the equipment	184
2.	Checking the tightening of screws	184
3.	Checking connections	184
9.10.2	Scanner unit.....	185
1.	Radiation section	185
2.	Rotation driving section	186
9.10.3	Display	187
Cleaning display	187	

Attached Figures

- [Fig. 101 INTERCONNECTION DIAGRAM OF JMA-5104]
- [Fig. 102 INTERCONNECTION DIAGRAM OF JMA-5106]
- [Fig. 103 INTERCONNECTION DIAGRAM OF JMA-5110]
- [Fig. 104 PRIMARY POWER SYSTEM DIAGRAM OF JMA-5104]
- [Fig. 105 PRIMARY POWER SYSTEM DIAGRAM OF JMA-5106]
- [Fig. 106 PRIMARY POWER SYSTEM DIAGRAM OF JMA-5110]
- [Fig. 107 INTERNAL CONNECTION OF SCANNER UNIT NKE-2042]
- [Fig. 108 INTERNAL CONNECTION OF SCANNER UNIT NKE-2062]
- [Fig. 109 CIRCUIT DRAWING OF MODULATOR UNIT CME-322]
- [Fig. 110 CIRCUIT DRAWING OF MODULATOR UNIT CME-323]
- [Fig. 111 INTERNAL CONNECTION OF DISPLAY UNIT NCD-4310]
- [Fig. 112 CIRCUIT DRAWING OF POWER SUPPLY UNIT CBD-1638]

Chapter 1 Introduction

1.1 Functions

This device is a marine radar device that utilizes a scanner unit including transmitter and receiver and 10.4 inch liquid crystal display unit and uses a compact raster scan method for achieving a fully semiconductor adopted (except for special electron tubes) system.

This equipment comprises radar as defined in the Wireless Telegraphy Act.

1.2 Features

Enhanced fundamental performance of the radar

Through switching among 4 steps in terms of pulse width/cycle switching of frequency and switching among 3 steps in receiver bandwidth, enhanced fundamental performance of the radar has been achieved towards display of clearer and high quality images. Moreover, through the incorporation of advanced digital signal processing, performance in target de-tection during increment weather has been improved.

Confirmation of the ship's position and identifying the waypoint at a glance

Through connecting to external navigation equipment such as GPS, the location of the ship (numerical values) or a mark on the waypoint may be displayed on the screen. This allows for confirmation of the difference between the waypoint and the ship's heading at a glance.

High operability

A jog dial has been incorporated for simple operation of menu selections, EBL/VRM.

The track ball may also be used to capture the MARPA target in a simple manner.

A system for the direct display of menu items that are frequently used with dedicated keys has been adopted.

1.3 Composition

Radar configuration and ship's power

Comprehensive model name	Scanner unit	Processing unit	Keyboard unit	Display unit	Ship's power supply
JMA-5104 JMA-5106 JMA-5110	NKE-2042 NKE-2062 NKE-2102	NDC-1260	NCE-7640	NWZ-146	DC (12V/24V/32V) DC (12V/24V/32V) DC (24V/32V)

When an optional rectifier unit is used: (AC100V/110V/115V/200V/220V/230V) 50/60Hz single phase

Rectifier unit model name (optional) : NBA-797

Note

When AC power supply is used, an optional rectifier unit is necessary.

The English presentation of the nameplate of each unit is as follows.

SCANNER UNIT

PROCESSING UNIT

KEYBOARD UNIT

DISPLAY UNIT

RECTIFIER UNIT

Attachments

Item name	Quantity	JRC code	Remarks
Instruction manual	1	7ZPRD0590	This manual (English)
Cable between a scanner unit and a processing unit	1	CFQ6912-20	19-core composite cable Standard length 20m
Power cable	1	CFQ-6911-5	5m

Spare parts

Spare parts are provided for each of the indicator unit and the scanner unit.

The following table lists spare parts for each unit.

Spare parts for the indicator unit (7ZRD0010) included in the same package as the processing unit

Item name	Quantity	JRC code	Remarks
Fuse (M60NR-10A)	3	5ZFAD00018	(Processing unit F1:10A)
6-pin connector	1	5JCDX00014	For NMEA data communication
8-pin connector	1	5JCDX00015	For NMEA data communication

Note

Only a 10A fuse is available for processing unit F1 (fuse for the indicator unit power) regardless of the input power voltage and transmission output.

NKE-2042 (spare parts for 4kw scanner unit) included in the same package as scanner unit 7ZXR0012

	Item name (model name)	Quantity	JRC code	Remarks
12V input	Fuse (SM6.3)	4	5ZFAD00543	For modulator (processing unit F2:6.3A)
	Not required	–		For motor (processing unit F3:)
24/32V input	Fuse (SM3.15)	4	5ZFAD00359	For modulator (processing unit F2:3.15A)
	Not required	–		For motor (processing unit F3:)

Note

For the 4kw scanner unit, insertion of F3 in the processing unit (fuse for motor) is not required since the power supply is shared between the modulator and the motor. Therefore, there are no spare parts.

NKE-2062 (spare parts for 6kw scanner unit) included in the same package as scanner unit 7ZXR0013

	Item name (model name)	Quantity	JRC code	Remarks
12V input	Fuse (SM6.3)	4	5ZFAD00543	For modulator (processing unit F2:6.3A)
	Fuse (SM5)	4	5ZFAD00393	For motor (processing unit F3:5A)
24/32V input	Fuse (SM3.15)	4	5ZFAD00359	For modulator (processing unit F2:3.15A)
	Fuse (SM5)	4	5ZFAD00393	For motor (processing unit F3:5A)

1.4 Configuration

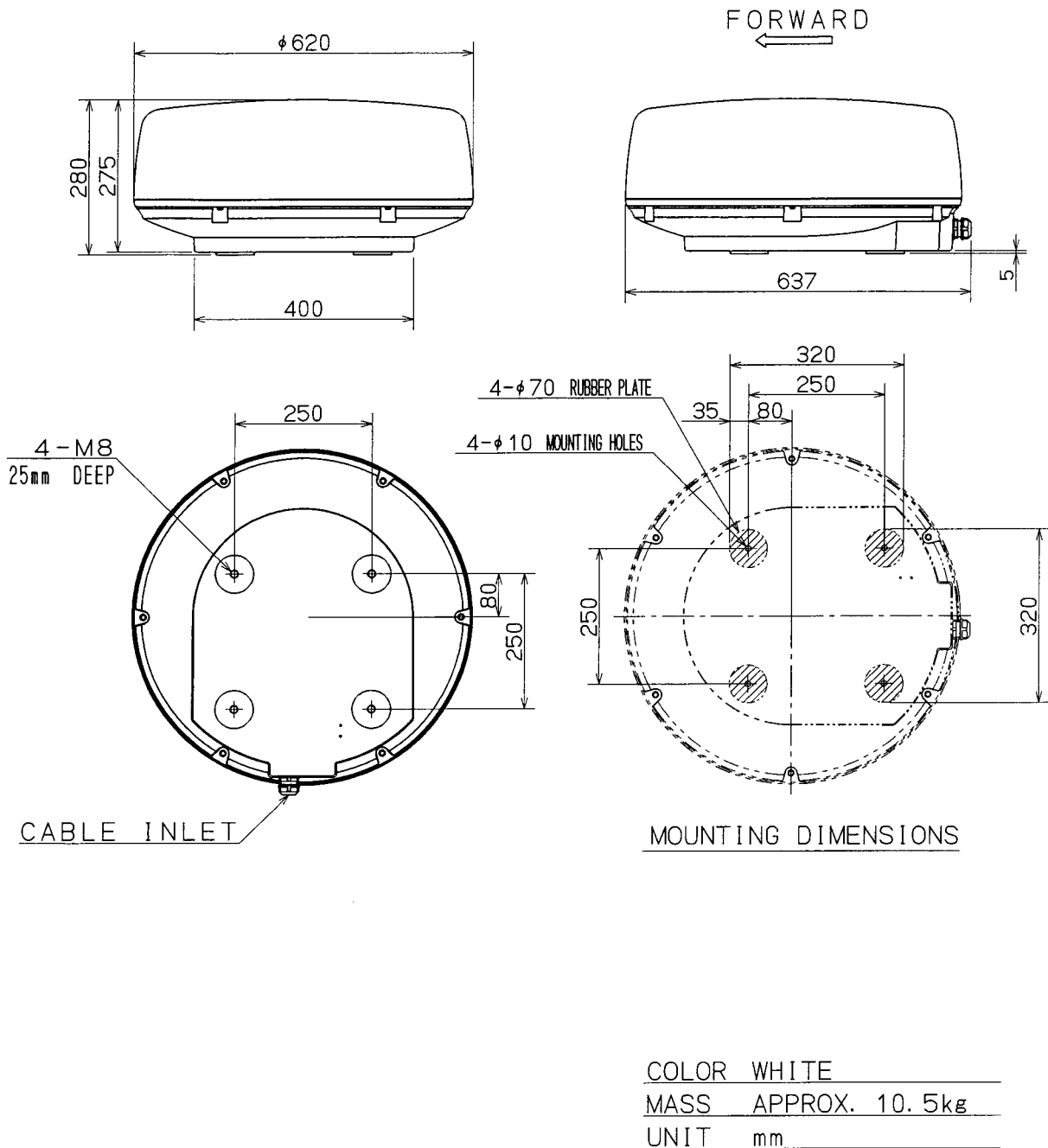

Fig. 1.1 OUTLINE DRAWING OF SCANNER UNIT NKE-2042

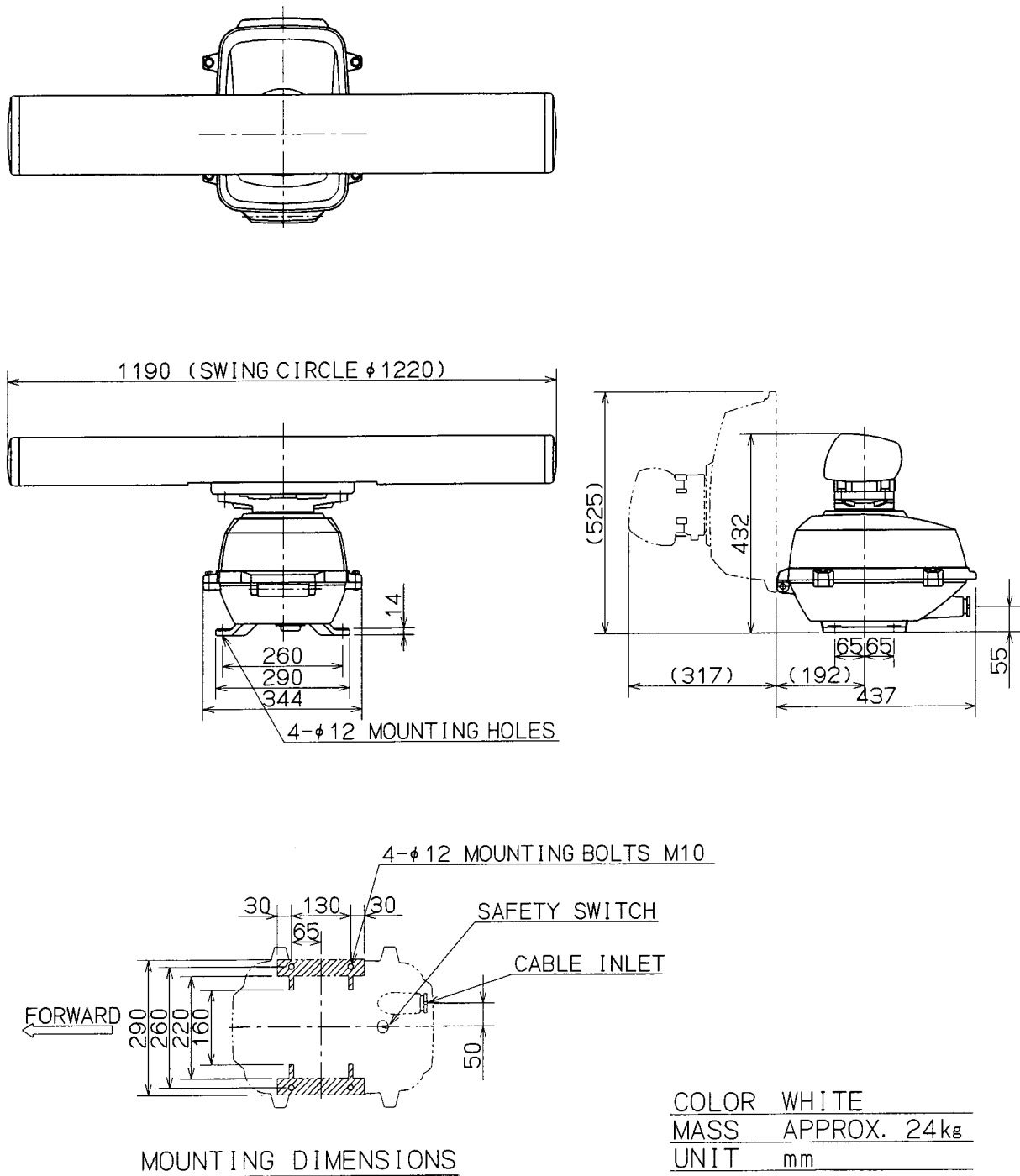

Fig. 1.2 OUTLINE DRAWING OF SCANNER UNIT NKE-2062

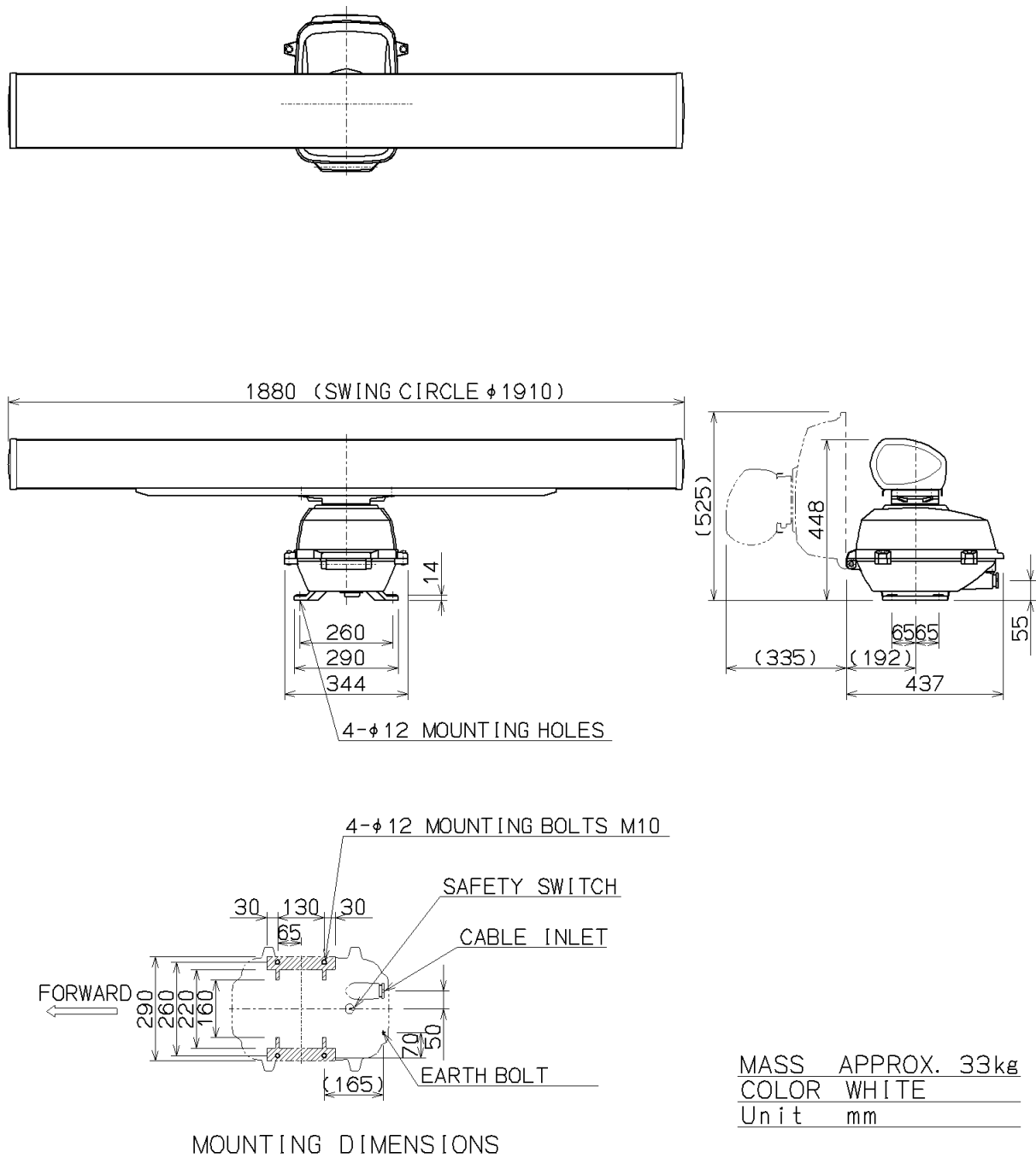
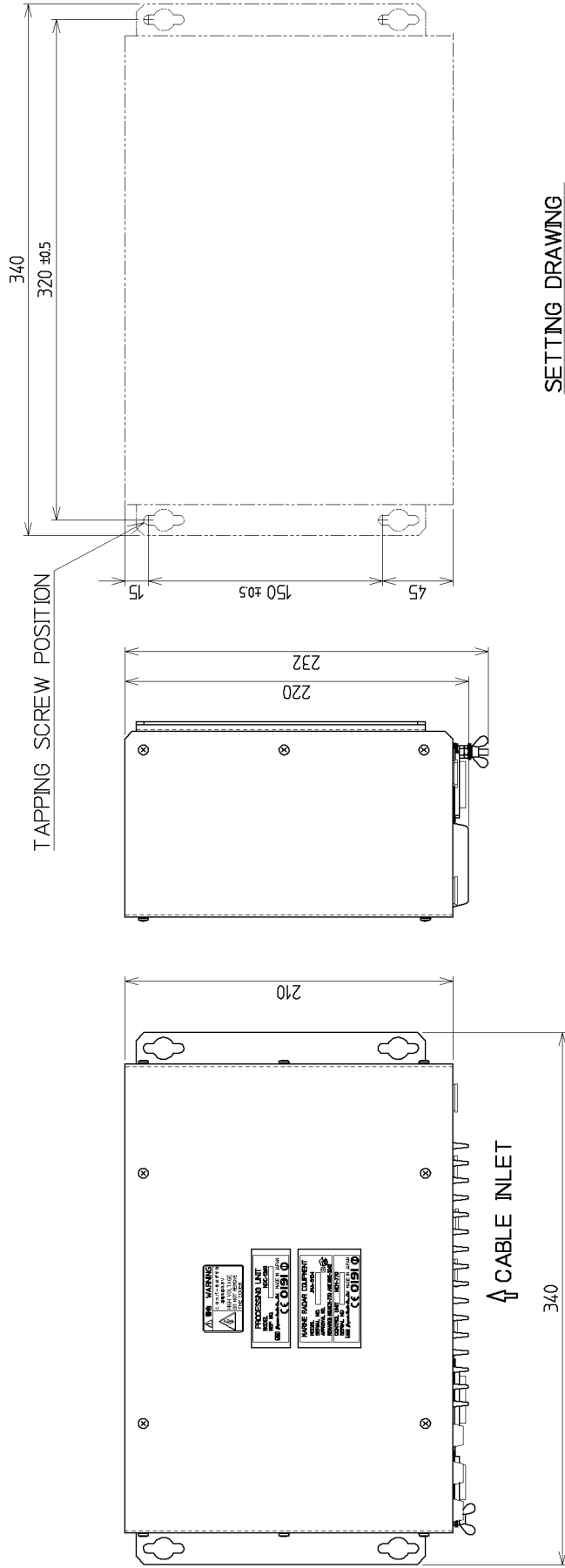

Fig. 1.3 OUTLINE DRAWING OF SCANNER UNIT NKE-2102



SETTING DRAWING

UNLESS OTHERWISE SPECIFIED

DIMENSION SPECIFIED	TOLERANCE
0 TO 30	± 1
OVER 30 TO 120	± 1.5
OVER 120 TO 400	± 2.5
OVER 400 TO 1000	± 4
OVER 1000 TO 2000	± 6
OVER 2000 TO 3000	± 8

CASE COLOR : MUNSELL N4
 MASS : 2.4 kg

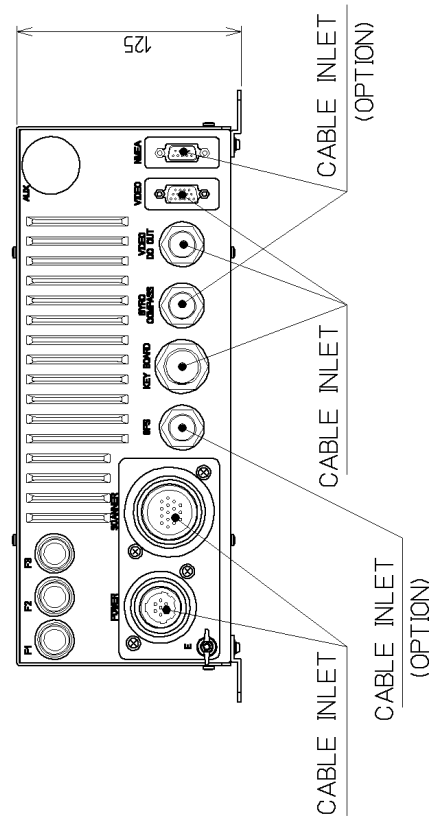
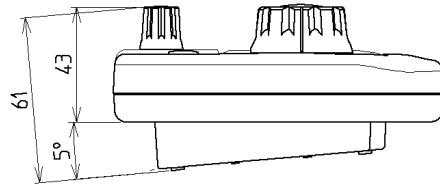
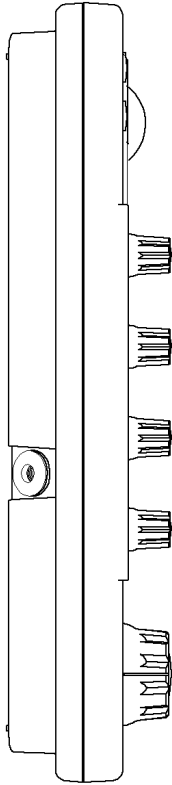

Fig. 1.4 OUTLINE DRAWING OF PROCESSING UNIT NDC-1260

↓ CABLE INLET



290

↓ CABLE INLET

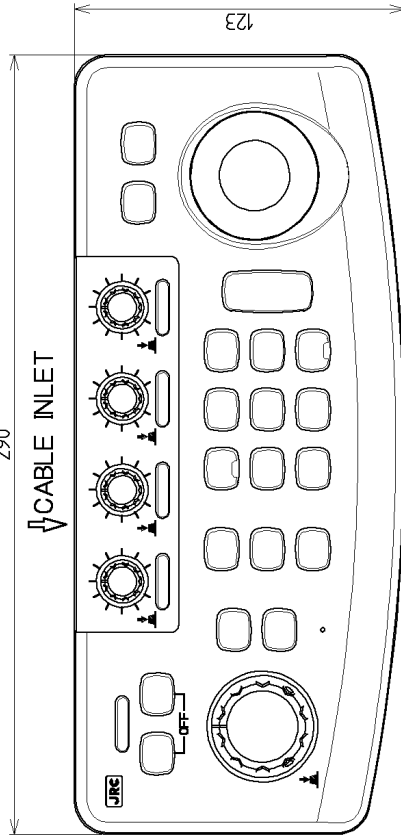

123

ATTACH VELCRO

REAR

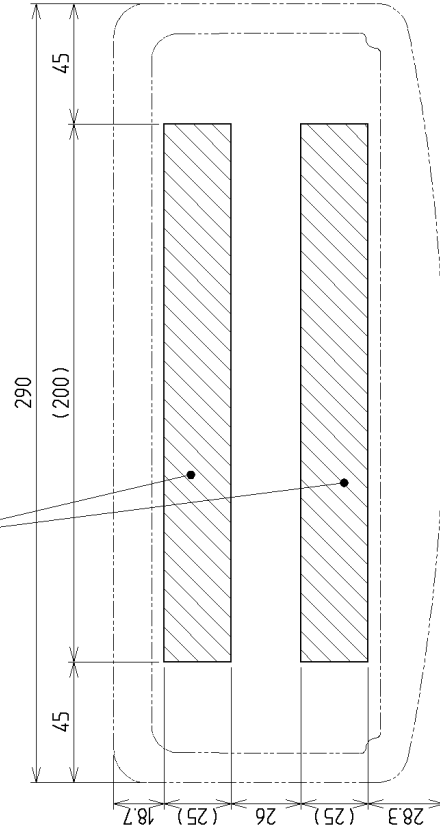

FRONT

SETTING DRAWING

UNLESS OTHERWISE SPECIFIED

DIMENSION SPECIFIED	TOLERANCE
0 TO 30	± 1
OVER 30 TO 120	± 1.5
OVER 120 TO 400	± 2.5
OVER 400 TO 1000	± 4
OVER 1000 TO 2000	± 6
OVER 2000 TO 3000	± 8

CASE COLOR : MUNSELL N4

MASS : 1 kg
(Contained the 5m cable)

Fig. 1.5 OUTLINE DRAWING OF KEYBOARD UNIT NCE-7640

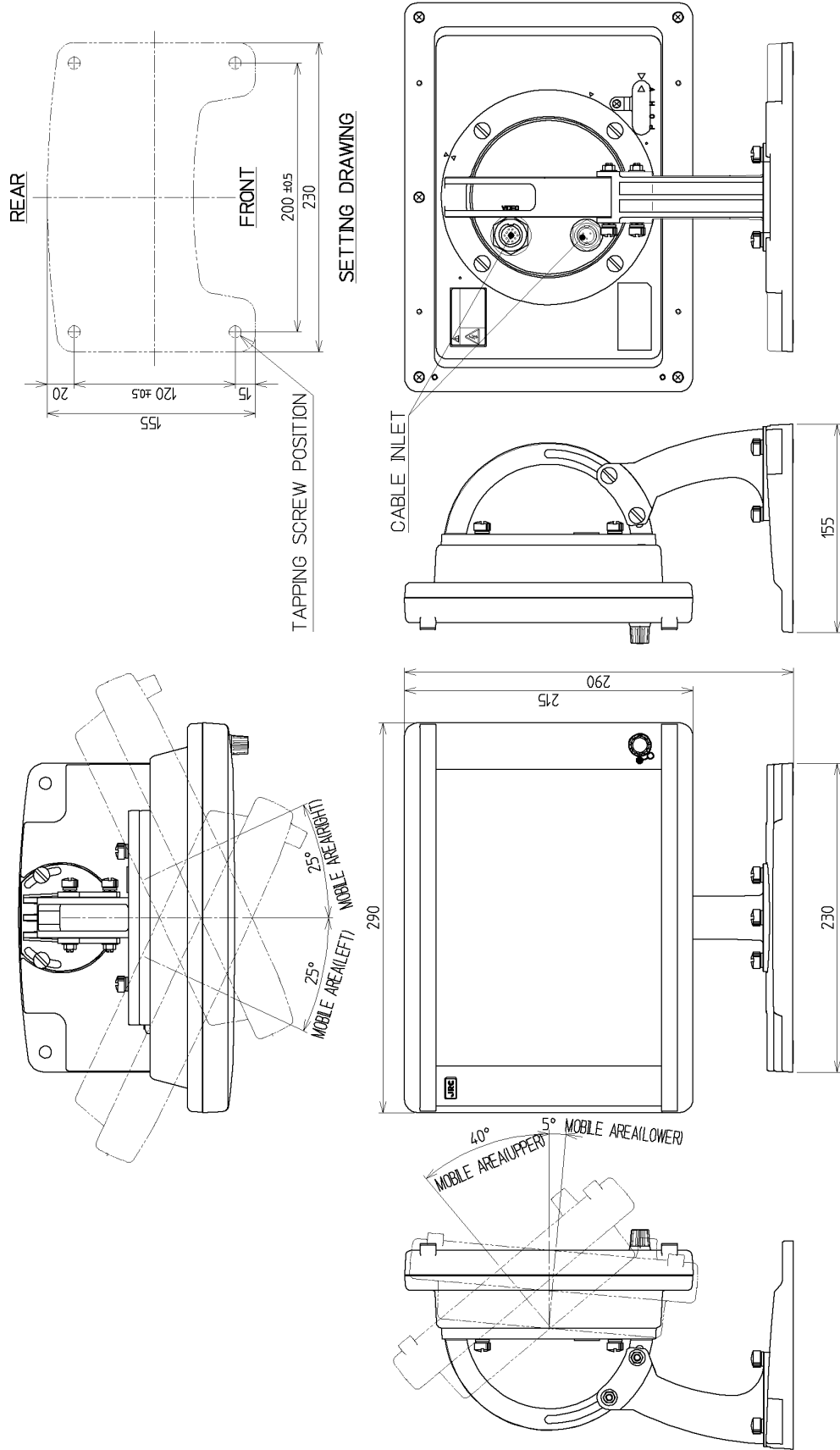

CASE COLOR :MUNSELL_N4
 MASS : 2.8 kg

UNLESS OTHERWISE SPECIFIED

DIMENSION SPECIFIED	TOLERANCE
0 TO 30	± 1
OVER 30 TO 120	± 1.5
OVER 120 TO 400	± 2.5
OVER 400 TO 1000	± 4
OVER 1000 TO 2000	± 6
OVER 2000 TO ∞	± 8

Fig. 1.6 OUTLINE DRAWING OF DISPLAY UNIT NWZ-146 (LANDSCAPE)

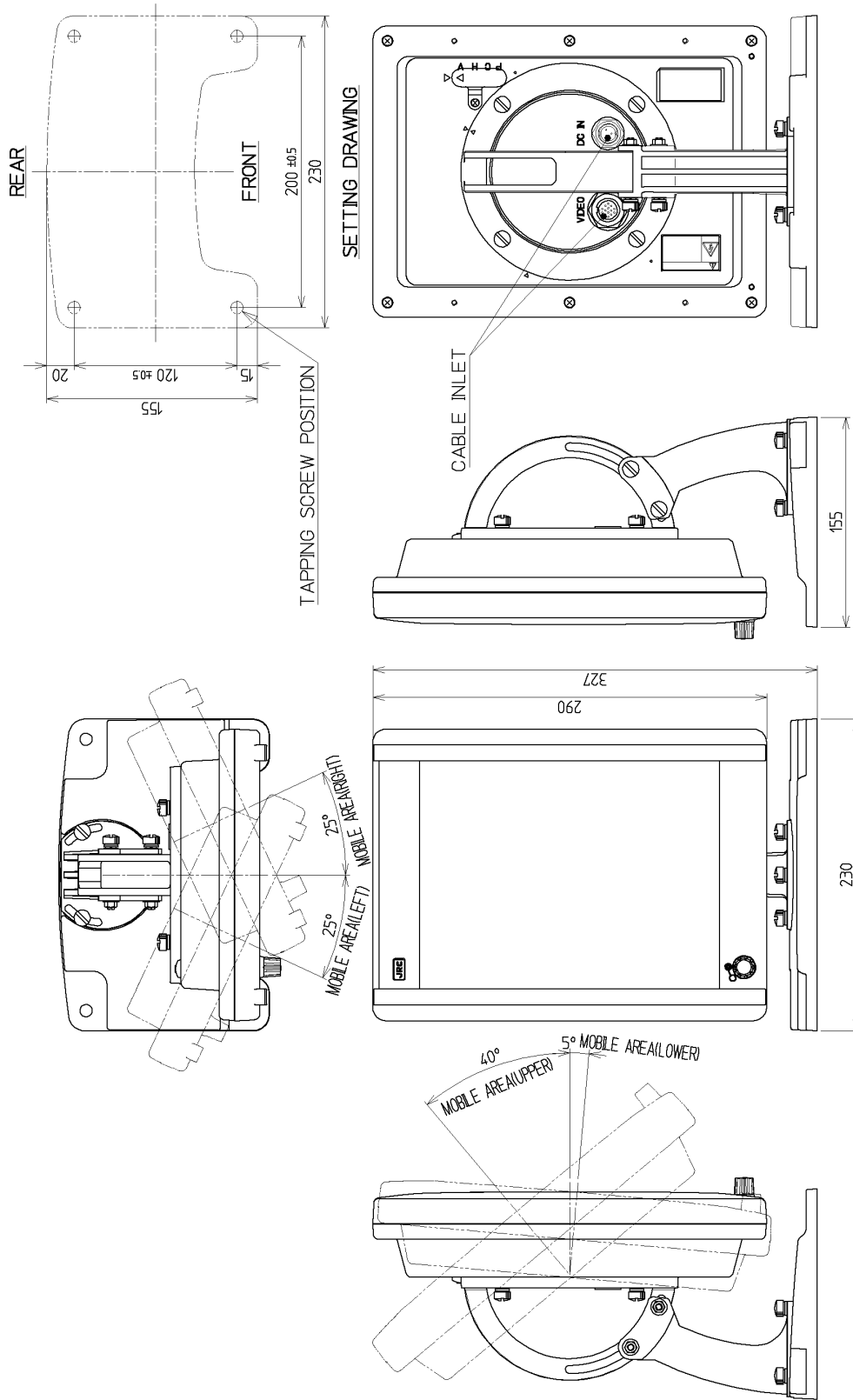

CASE COLOR : MUNSSELL N4
 MASS : 2.8 kg

UNLESS OTHERWISE SPECIFIED

DIMENSION SPECIFIED	TOLERANCE
0 TO 30	± 1
OVER 30 TO 120	± 1.5
OVER 120 TO 400	± 2.5
OVER 400 TO 1000	± 4
OVER 1000 TO 2000	± 6
OVER 2000 TO 3000	± 8

Fig. 1.7 OUTLINE DRAWING OF DISPLAY UNIT NWZ-146 (PORTRAIT)

1.5 General System Diagram

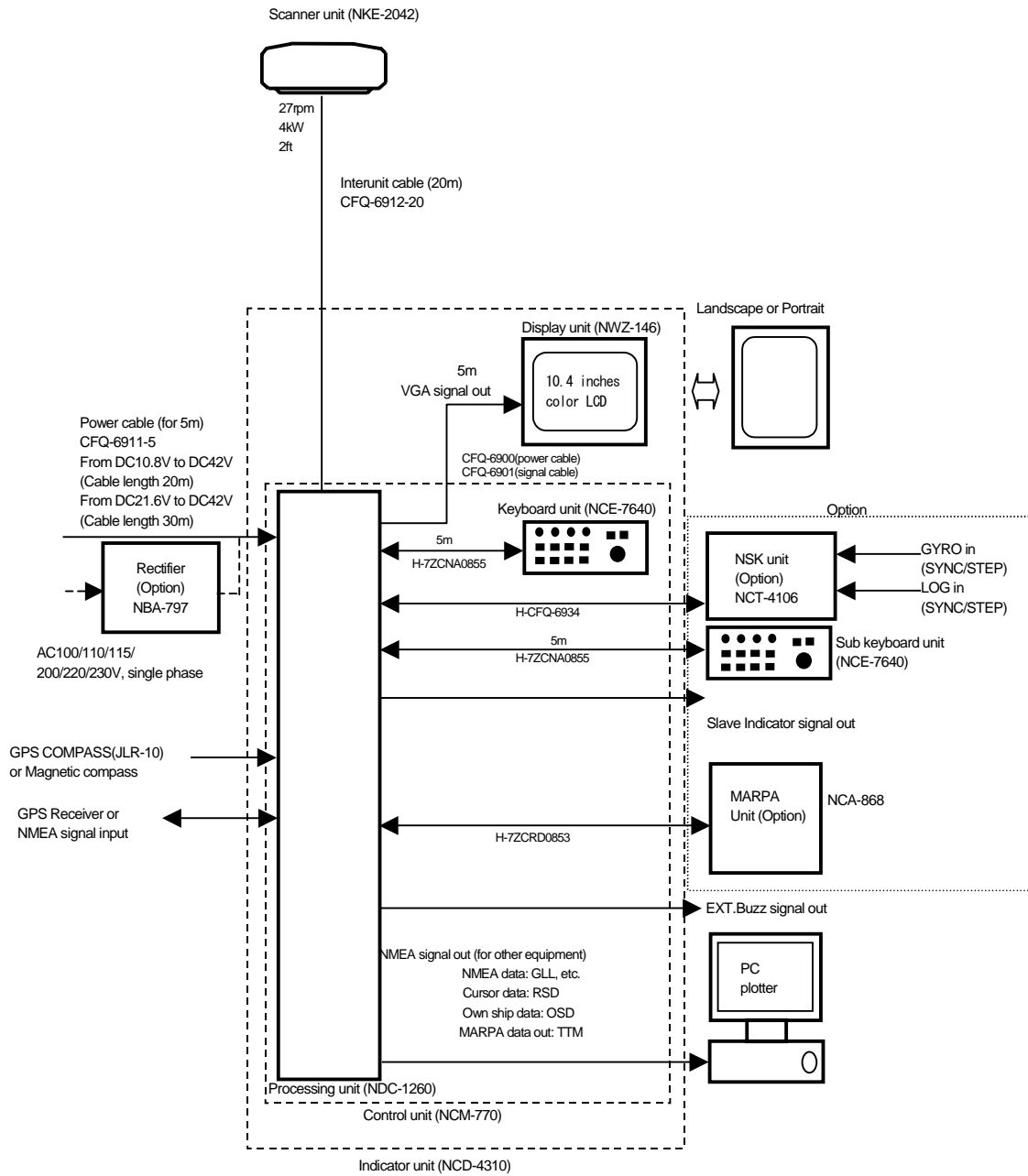

NOTES :

ELIMINATING THE INTERFERENCE ON FREQUENCIES USED FOR MARINE COMMUNICATIONS AND NAVIGATION DUE TO OPERATION OF THE RADAR. ALL CABLES OF THE RADAR ARE TO BE RUN AWAY FROM THE CABLES OF RADIO EQUIPMENT. (EX. RADIOTELEPHONE. COMMUNICATIONS RECEIVER AND DIRECTION FINDER. ETC.) ESPECIALLY INTER-WIRING CABLES BETWEEN SCANNER UNIT AND DISPLAY UNIT OF THE RADAR SHOULD NOT BE RUN PARALLEL WITH THE CABLES OF RADIO EQUIPMENT.

Fig. 1.8 GENERAL SYSTEM DIAGRAM OF JMA-5104

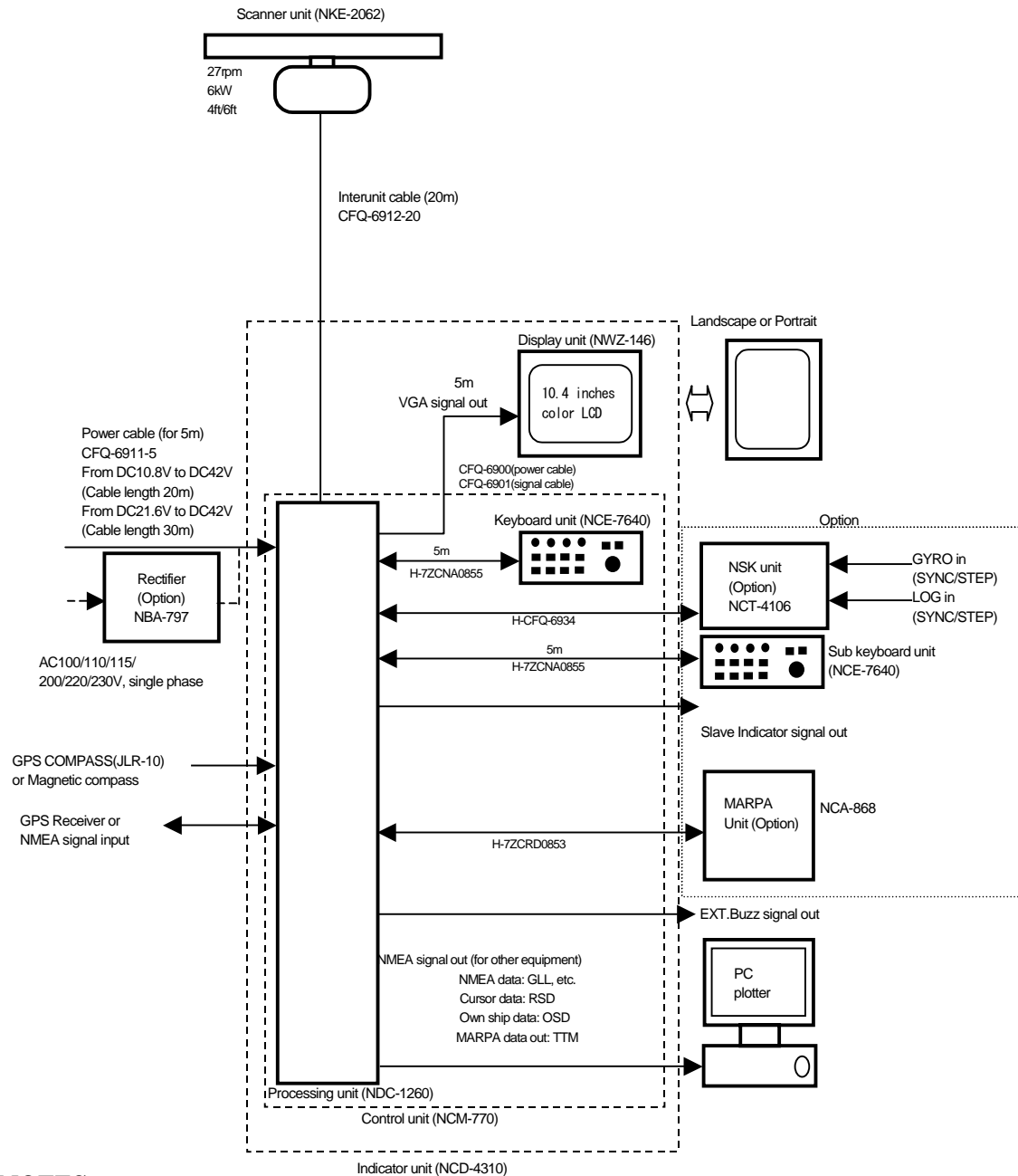

NOTES :

ELIMINATING THE INTERFERENCE ON FREQUENCIES USED FOR MARINE COMMUNICATIONS AND NAVIGATION DUE TO OPERATION OF THE RADAR.

ALL CABLES OF THE RADAR ARE TO BE RUN AWAY FROM THE CABLES OF RADIO EQUIPMENT.

(EX. RADIOTELEPHONE.COMMUNICAITONS RECEIVER AND DIRRECTION FINDER.ETC.) ESPECIALLY INTER-WIRING CABLES BETWEEN SCANNER UNIT AND DISPLAY UNIT OF THE RADAR SHOULD NOT BE RUN PARALLEL WITH THE CABLES OF RADIO EQUIPMENT.

Fig. 1.9 GENERAL SYSTEM DIAGRAM OF JMA-5106

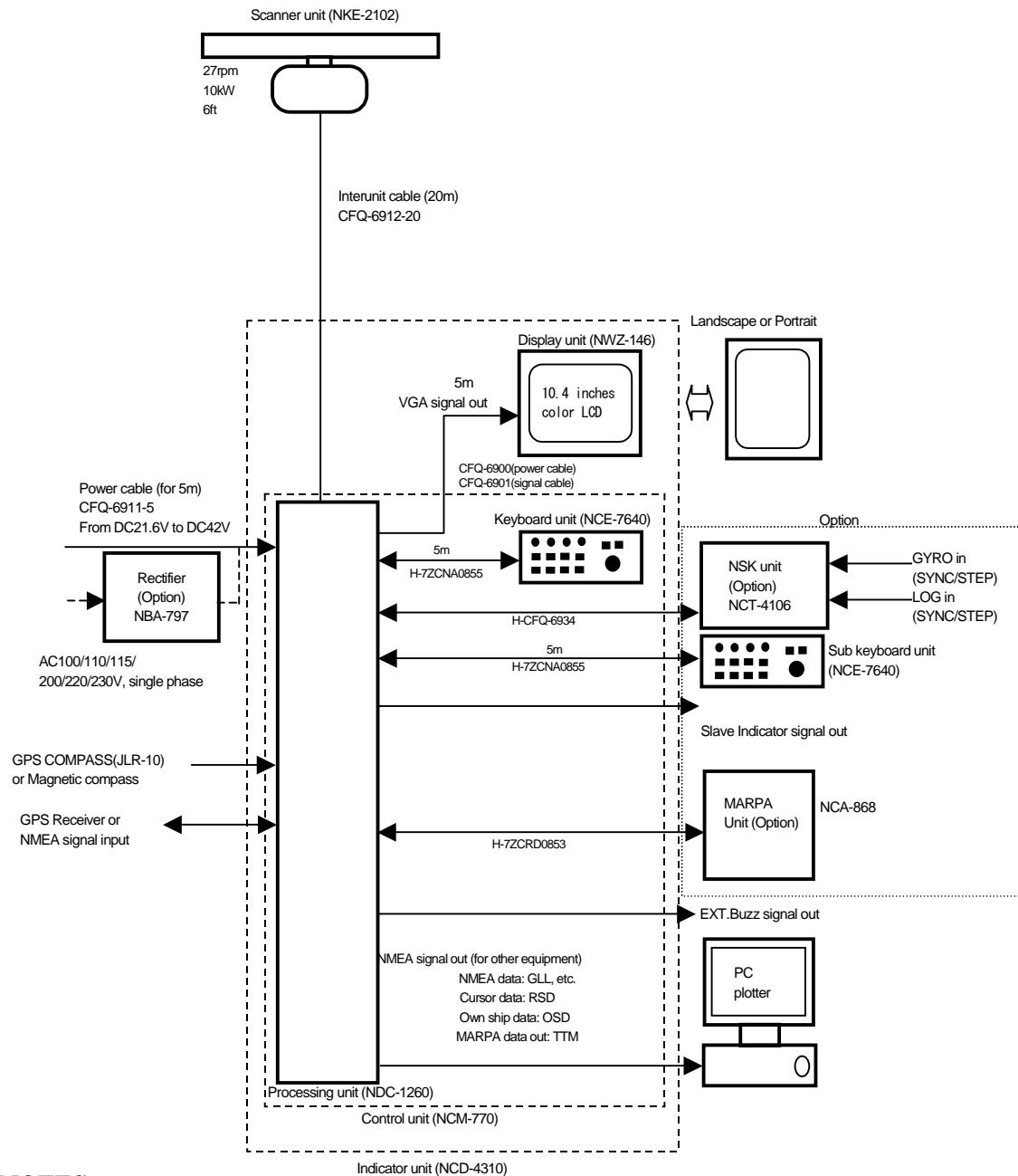

NOTES :

ELIMINATING THE INTERFERENCE ON FREQUENCIES USED FOR MARINE COMMUNICATIONS AND NAVIGATION DUE TO OPERATION OF THE RADAR. ALL CABLES OF THE RADAR ARE TO BE RUN AWAY FROM THE CABLES OF RADIO EQUIPMENT. (EX. RADIOTELEPHONE. COMMUNICAITONS RECEIVER AND DIRRECTION FINDER. ETC.) ESPECIALLY INTER-WIRING CABLES BETWEEN SCANNER UNIT AND DISPLAY UNIT OF THE RADAR SHOULD NOT BE RUN PARALLEL WITH THE CABLES OF RADIO EQUIPMENT.

Fig. 1.10 GENERAL SYSTEM DIAGRAM OF JMA-5110

Chapter 2 Names and Functions in the Keyboard Unit and the Menu Structure

2.1 Functions of the Keyboard

The normal operations of this radar equipment can be performed using the switches, volume knob, jog dial, and track ball on the keyboard unit.

The operations are simple, however it is important to understand that the function of each operation unit is to obtain the required information on the LCD screen of the display unit.

2.1.1 Outline of the keyboard functions

The keyboard unit consists of the following four main components.

[Key], **[Knob]**, **[Jog dial]**, and **[Track ball]**

Each of these components is described below.

The correspondence between the operation method and the function is described below.

The notation enclosed by brackets [] indicates a key, a knob, a jog dial, or a track ball on the keyboard.

Example of a key : **[CLEAR]**

Example of a knob : **[AUTO-SEA]**

Jog dial : **[JOG DIAL]**

Track call : **[Track Ball]**

A boxed notation (XXXX) indicates display of a menu item.

Example : BASIC

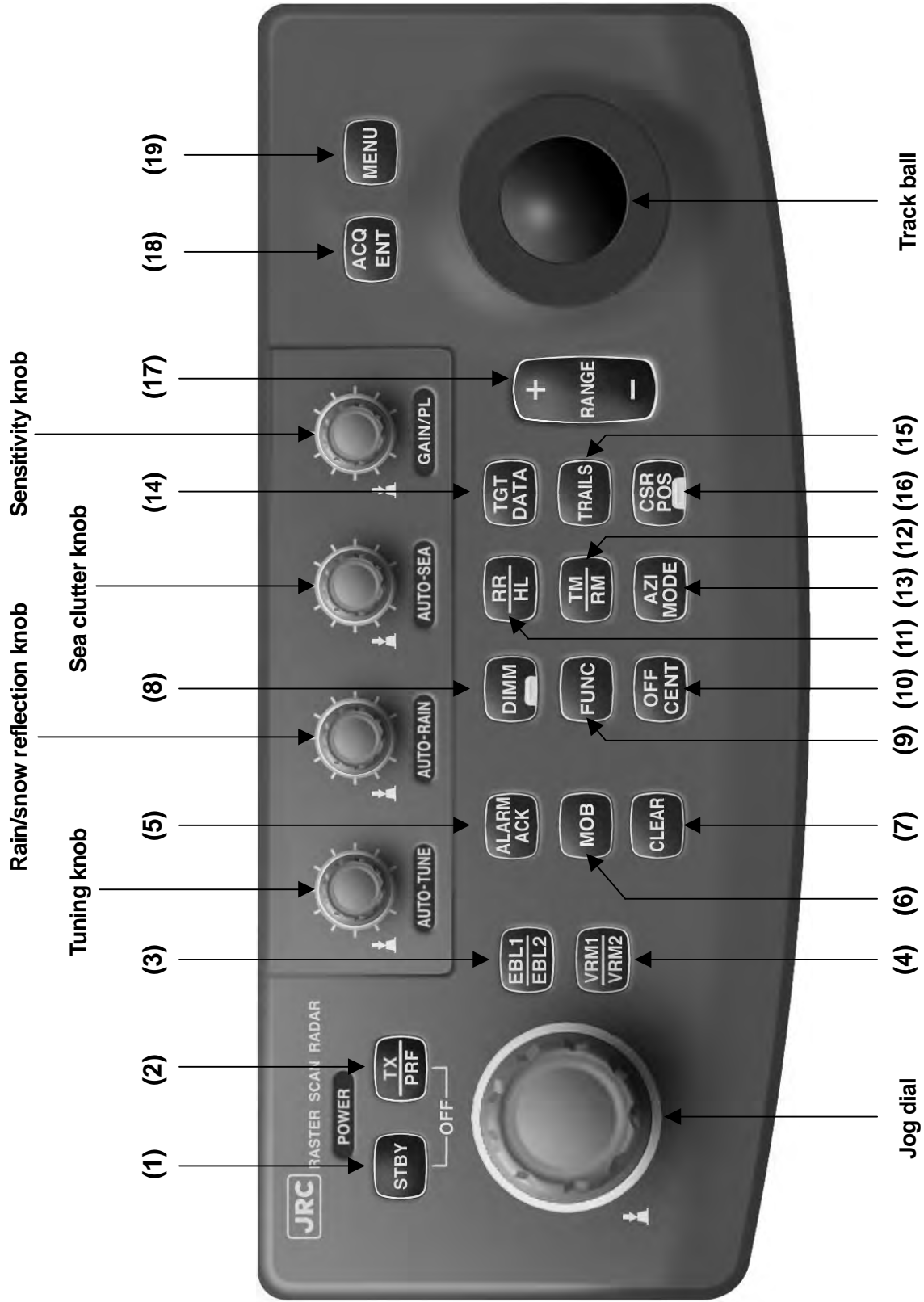

2.1.2 Configuration and functions of the keys on keyboard

Nineteen keys on keyboard are available in total.

The keys on keyboard are classified into two major types based on the operation mode; keys in **short mode** and keys in **long mode**.

A short mode is mainly used for setting key functions to ON/OFF and a long mode is used for displaying detail menus related to the key functions.

This method enables users to set related key functions directly with fewer keys.

A short mode refers to the pressing of a key for short time and a long mode refers to the pressing of a key for two seconds or more continuously.

The functions of the keys in short mode and those in long mode are described below.

(1) [STBY] key

Short mode : Power ON

Long mode : The power is turned off when this key is pressed together with [TX/PRF] key in long mode.

(2) [TX/PRF] key

Short mode : When this key is pressed from a standby state, the equipment is set to a transmission state. When this key is pressed in a transmission state, the repetition frequency is changed.

Long mode : The power is turned off when this key is pressed together with the [STBY] key in long mode.

(3) [EBL1/EBL2] key

Short mode : EBL ON/OFF of EBL

Long mode : Switches EBL1/EBL2.

(4) [VRM1/VRM2] key

Short mode : VRM ON/OFF

Long mode : Switches VRM1/VRM2

(5) [ALARM ACK] key

Short mode : Stops alarm buzzer.

Long mode : Displays alarm detail setting/error log.

(6) [MOB] key

Short mode : Starts the MOB function.

Long mode : Stops the MOB function.

(7) [CLEAR] key

In short mode, the operation varies depending on whether it is during menu operation and other states, which are described later.

During menu operation

Short mode : During item selection on a menu, this key stops the current item selection.
When item selection is completed, this key returns control to the menu one level above.

State other than menu operation

Short mode : When this key is pressed while the operation overlaps with the ATA symbol, this operation erases the ATA symbol.

When the key is pressed while it does not overlap with the ATA symbol, the target of the symbol number that is selected by numeric display is erased.

Long mode : Erases the entire ATA symbol.

(8) [DIMM] key

Short mode : Changes the brightness of the key on the keyboard unit.

Long mode : Displays a day/night menu.

(9) [FUNC] key

Short mode : Switches the function setting.

Long mode : Displays a function setting menu.

(10) [OFF CENT] key

Short mode : Moves the center to the cursor position/returns to the center.

Long mode : Continuously moves the center.

(11) [RR/HL] key

Short mode : FIXM ON/OFF

Long mode : Sets the display of a highlighted line of the bow of the ship to OFF.

(12) [TM/RM] key

Short mode : Switches TM/RM/CTM (unlimited TM).

Long mode : Applies manual reset in TM mode.

(13) [AZI MODE] key

Short mode : Switches an azimuth mode (HUP/NUP/CUP).

Long mode : Displays a gyro setting menu.

(14) [TGT DATA] key

Short mode : Displays target information or the next target information.

(When a target is being displayed)

Long mode : Set ATA display to ON/OFF.

Switches the display when MOB/WPT is set to ON.

MOB → ATA → WPT → MOB

(15) [TRAILS] key

Short mode : Switches to time track/continuous track/time track + continuous track/non-display.

Long mode : Displays a track menu (track erase, track time setting change, and so on).

(16) [CSR POS] key

Short mode : Outputs the information of the bearing and distance from the current own ship's position to cursor position. It is output by the serial communication from the RS232C port.

Long mode : Outputs the information of the bearing and distance when the cursor is the own ship's position. It is output by the serial communication from the RS232C port. (Outputs "distance = 0NM", "bearing=0 degree").

(17) [+RANGE-] key

Short mode : Switches the range (+: range up, -: range down).

Long mode : Switches the continuous range (+: continuously range up, -: continuously range down)

* When the **[+RANGE-]** key is pressed while the zoom function is ON, the zoom function is automatically released.

(18) [ACQ/ENT] key

Short mode : Target capture

Long mode : ACQ mode menu

(19) [MENU] key

Short mode : Set a menu to ON/OFF.

Long mode : Set an initialization menu to ON/OFF

* Initialization refers to the settings made at installation.

2.1.3 Structure and the functions of knobs

Four knobs are available.

The knobs are classified into three main modes based on the operation. One type is a **knob operation mode** and other two are a **short mode** and a **long mode**, similar to the key operations.

In knob operation mode, the values change according to the rotation of the knob. The short mode and the long mode are the same operation as for the keys.

The function of each knob is described below.

[AUTO-TUNE] knob

Short mode : Switches to automatic/manual.

Long mode : When the power supply is set to ON while this key is pressed, horizontal orientation display is set (12 o'clock).

Knob operation : The equipment is tuned when the knob is set to the center.

[AUTO-RAIN] knob

Short mode : Switches to automatic/manual.

Long mode : When the power supply is set to ON while this key is pressed, vertical clockwise rotation display is set (3 o'clock).

Knob operation : The control function reaches the maximum when the knob is turned to the full position in the clockwise direction and the minimum when the knob is turned to the full position in the anti-clockwise direction.

[AUTO-SEA] knob

Short mode : Switches to automatic/manual.

Long mode : When the power supply is set to ON while this key is pressed, horizontal reverse orientation display is set (6 o'clock).

Knob operation : When the knob is turned to the full position in clockwise direction, the control function reaches the maximum level and when the knob is turned to the full position in the anti-clockwise direction, the control function reaches the minimum level.

[GAIN/PL] knob

Short mode : Switches a transmission pulse width.

Long mode : Displays a panel 1/2 switching menu while the power is supplied.
When the power is not supplied, vertical anti-clockwise rotation display is set if the power supply is set to ON (9 o'clock).

Knob operation : When the knob is turned to the full position in the clockwise direction, the sensitivity reaches the maximum level and when the knob is turned to the full position in the anti-clockwise direction, the sensitivity reaches the minimum level.

2.1.4 Structure and functions of the jog dial

Three jog dial operation modes are available. One mode is a **knob operation mode** and other two are a **short mode** and a **long mode**, similar to the key operations.

Rotation mode : In this mode, items displayed on EBL/VRM/ATA display/menu changes when the jog dial is turned. The cursor on the bottom-right of the screen and the characters displayed on the right-hand side indicates which rotation mode is the current mode.

Rotation modes an mode display

Purpose	Mode name	Characters that are displayed on the bottom-right of the screen
EBL setting	EBL mode	JOG EBL1*
VRM setting	VRM mode	JOG VRM1*
Switching MARPA value data display	MARPA display mode	JOG ATA
Menu display	Menu selection mode	JOG MENU

*At operation 1 and 2, EBL1, EBL2, VRM1, and VRM2 are displayed respectively.

The operations in short mode and long mode are the same as key operations in those modes.

Short mode : When menu display is not set, the mode is switched to EBL/VRM/ATA operation mode whenever the jog dial is pressed.

This mode determines the menu of the line that was selected when a menu is displayed.

(Same operation as [ACQ/ENT])

Long mode :

2.1.5 Structure and functions of the track ball

Normally **[TRACK BALL]** is used for operating a cross cursor.

When **[TRACK BALL]** is moved, the distance from own ship and the azimuth are displayed at the bottom-left corner of the screen. When navigation equipment is connected, the latitude and longitude are also displayed. When a MARPA function is attached, a required target can be captured by moving the cross cursor by operating **[TRACK BALL]** to the target.

By pressing the **[OFF CENT]** key, the center of PPI can be moved to the cross cursor position.

By moving **[TRACK BALL]** while pressing the **[OFF CENT]** key in long mode, the center of PPI can be moved to the position of **[TRACK BALL]** consecutively.

2.2 Description of Screen Display

<Horizontal display>

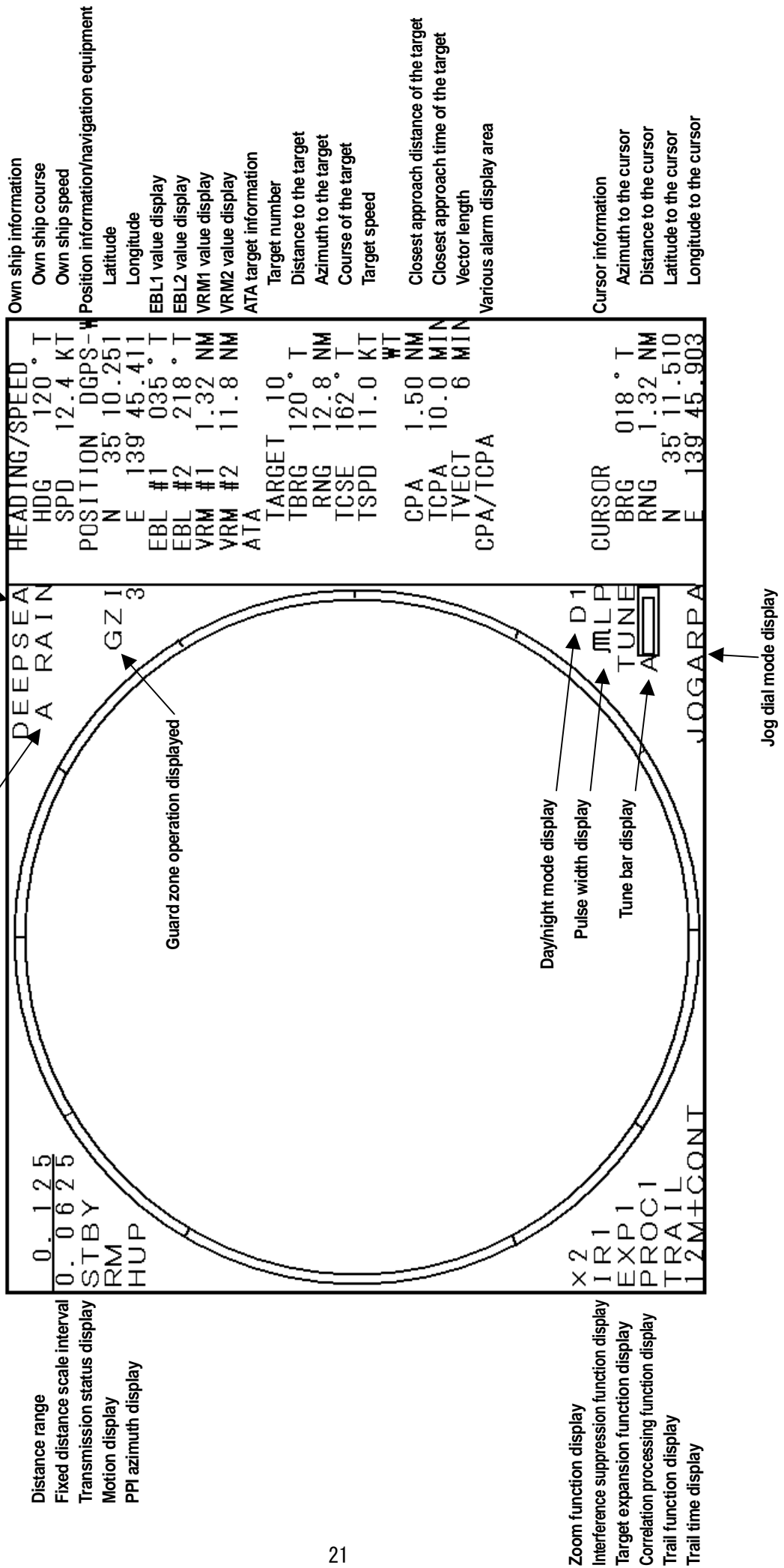

<Vertical display>

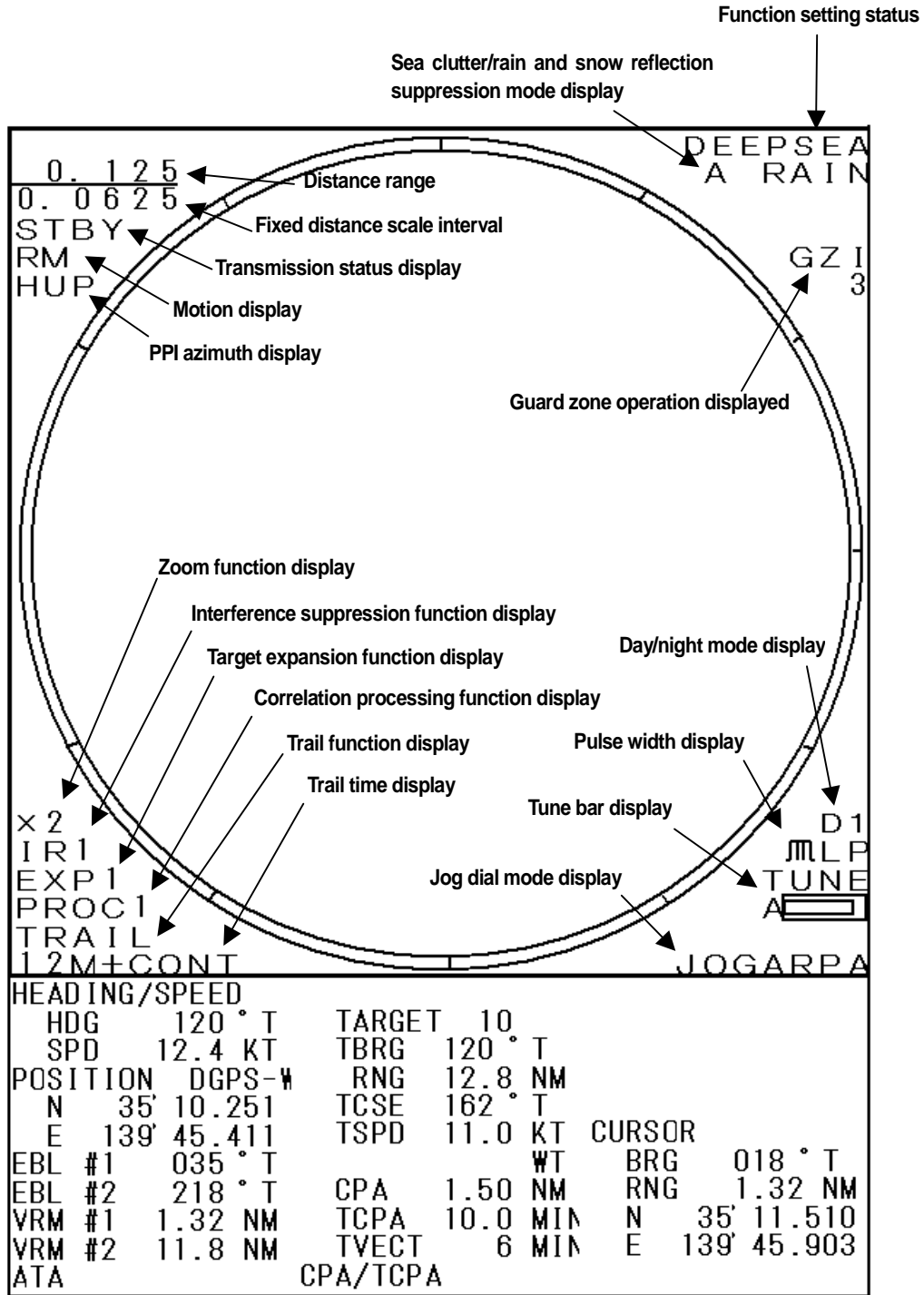

Own ship information

- Own ship course
- Own ship speed
- Position information/navigation equipment
- Latitude
- Longitude
- EBL1 value display
- EBL2 value display
- VRM1 value display
- VRM2 value display

ATA target information

- Target number
- Distance to the target
- Azimuth to the target
- Course of the target
- Target speed
- Closest approach distance of the target
- Closest approach time of the target
- Vector length

Various alarm display area

- Cursor information
- Azimuth to the cursor
- Distance to the cursor
- Latitude to the cursor
- Longitude to the cursor

2.3 Menu Functions

This radar equipment has the functions available through menus in addition to the functions available on the keyboard unit and volume knobs. This section describes the structure of the menus, the functions, and the setting method.

2.3.1 Menu structure

This radar equipment can display information in Japanese, English, and other languages (French, Spanish, Italian, Danish, and Norwegian) on the screen by switching.

- See 3.3.3, "Switching the display language [DIMM]" for switching a display language.

Opening a menu

Press the **[MENU]** key to display a menu.

Closing a menu

To close a menu, press the **[MENU]** key or keep pressing the **[CLEAR]** key until the menu is closed.

Moving to a menu at a lower level

Menus are organized in a hierarchical structure. To move control to a menu at a lower level, select the characters of a required menu item using **[JOG DIAL]** and press the **[JOG DIAL]** or **[ACQ/ENT]** key. Consequently, the menu at the lower level is displayed.

Moving to a menu at an upper level

To return control to a menu at the immediate upper level, press the **[CLEAR]** key. The menu at the immediate upper level is displayed.

Determining an item

To determine an item after changing the value using **[TRACK BALL]** or displaying the setting item in reverse video, press the **[JOG DIAL]** or **[ACQ/ENT]** key.

Menu lists are described below.

Menus are classified into general function setting menus that are displayed by pressing a key in short mode and setting menus at installation that are displayed by pressing a key in long mode.

General menu [MENU] (1/1 page)

1st level

MENU	
BASIC	>
DISP OPTIONS	>
TX PLAN	>
INFORMATION	>
HELP	>

Display method

Press [MENU] in short mode.

2nd level

BASIC	
INTERFERENCE	IR1
TGT EXPANSION	OFF
PROCESS	OFF
PROC SW RANGE	3.0
ECHO POWER	FULL
ZOOM	OFF

DISP OPTIONS	
EBL BEARING	TRUE
FROATING EBL	OFF
PARALLEL LINE	OFF
VRM1 UNITS	NM
VRM2 UNITS	NM
WAYPOINT	OFF
POSITION	LL
LL-TD CONV	>

TX PLAN	
TX PLAN	OFF
TX PERIOD	10 SCAN
STBY PERIOD	3 MIN

INFORMATION	
SOFTWARE VER.	
PORT CONNECT	

HELP	
INITIALIZE ALL	ACCENT+MENU
SELF TEST	EBL+VRM
LANGUAGE	ALM ACK
DISP MOUNT UP	TUNE
DISP MOUNT R	RAIN
DISP MOUNT REV	SEA
DISP MOUNT L	GAIN

→ **BASIC (3rd level menu available)**

Sets operation and processing mainly related to radar images.

→ **DISP OPTIONS (3rd and 4th level menus are available)**

Sets markers that are displayed in graphic mode and functions that display data from navigation equipment.

→ **TX PLAN (3rd level menu available)**

Sets an intermittent transmission mode and detail operation.

→ **INFORMATION (3rd level menu available)**

Displays the software version and operation status of the connected equipment.

→ **HELP**

Displays explanation of keys and menu operation.

Installation setting menu [MENU] (1/3 pages)

1st level

INSTALLATION	
GYRO SETTING	>
123.4°	>
RADAR	>
GPS	>
ATA SETTING	>
DATA/IN OUT	>
BAUD RATE	>
DISPLAY MOUNT	>
LCD SETTING	>
BACKUP MEMORY	>
INIT MENU	>

2nd level

GYRO SETTING	123.4°
SIMULATION	OFF
RADAR	>
GPS	>
ATA SETTING	>
DATA/IN OUT	>
BAUD RATE	>
DISPLAY MOUNT	>
LCD SETTING	>
BACKUP MEMORY	>
INIT MENU	>
INSTALLATION	



Display method

25 Press [MENU] in long mode.

GYRO SETTING	123.4°
SIMULATION	OFF
INTERNAL	>
EXTERNAL	>
DATA/IN OUT	>
BAUD RATE	>
DISPLAY MOUNT	>
LCD SETTING	>
BACKUP MEMORY	>
INIT MENU	>
INSTALLATION	

RADAR	
RADAR ADJUST	>
RADAR ADJUST2	>
RADAR SETTING	>
ROT SPEED	>

→ **GYRO SETTING**

Sets gyro data.

→ **SIMULATION**

Switches between a simulator mode and a normal mode alternately.

→ **RADAR ADJUST (3rd and 4th level menus available)**

Sets basic information at installation of radar equipment such as tuning, distance, and azimuth.

Installation setting menu [MENU] continued (2/3 pages)

1st level

INSTALLATION	
GYRO SETTING	123.4°
SIMULATION	OFF
RADAR	>
GPS	>
ATA SETTING	>
DATA/IN OUT	>
BAUD RATE	>
DISPLAY MOUNT	>
LCD SETTING	>
BACKUP MEMORY	>
INIT MENU	>

2nd level

GPS	
GPS SETTING	>
GPS SETTING2	>
DGPS SETTING	>
WAAS SETTING	>
GPS INFO	>

ATA SETTING	
ATA	OFF
LEVEL H	64
LEVEL L	64
LEVEL G	64
VECTOR CONST	4
AUTO ACQ	OFF
TEST VIDEO	OFF
NUMBERING	AUTO
GATE DISP	OFF

DATA/IN OUT	
COURSE IN	COMPASS GYRO
MANUAL COURSE	000°
SPEED IN	GPS BT
MANUAL SPEED	00.0 KT
POSITION IN	GPS
MANUAL POS.	N 36° 36.000'
	E136° 36.000'
COMPASS PORT	JLR-10 (9600)
2ND PANEL	DISABLE
NMEA OUT	>
CALIBRATION	

BAUD RATE	
PC	4800
PANEL	4800



Display method

26 Press [MENU] in long mode.

→ **GPS SETTING (3rd and 4th level menus available)**

Sets initial values in the GPS receiver.

→ **ATA SETTING (3rd level menu available)**

Initializes the optional MARPA.

→ **DATA/IN OUT (3rd and 4th level menus)**

Sets information for receiving data from a sensor such as speed, course, and position.

→ **BAUD RATE (3rd level menu available)**

Sets a communication speed with a personal computer.

Installation setting menu [MENU] Continued (3/3 pages)

1st level

INSTALLATION	
GYRO SETTING	123.4°
SIMULATION	OFF
RADAR	>
GPS	>
ATA SETTING	>
DATA/IN OUT	>
BAUD RATE	>
DISPLAY MOUNT	HORIZONTAL
LCD SETTING	>
BACKUP MEMORY	>
INIT MENU	>

2nd level

DISPLAY MOUNT	
GYRO SETTING	123.4°
SIMULATION	OFF
RADAR	>
GPS	>
ATA SETTING	>
DATA/IN OUT	>
DISPLAY MOUNT	HORIZONTAL
HORIZONTAL	
VERTICAL-RIGHT	
INVERSION	
VERTICAL-LEFT	



Display method

Press [MENU] in long mode.

→ **DISPLAY MOUNT**

Sets a display orientation of the display unit.

→ **LCD SETTING (3rd level menu available)**

Sets a display position of the LCD.

→ **BACKUP MEMORY**

LCD SETTING	
HS DISP START	143
VS DISP START	37

BACKUP MEMORY	
STORE	>
LOAD	>

Menu by a direct key [TRAILS] (1/1 page)

1st level

TRAILS	
TRAIL INTERVAL	6M
TRAIL REF LVL	8
TRAIL SUPPRESS	0. ONM
TRAIL CLEAR	OFF
RANGE TRAIL	CLEAR

2nd level

TRAILS	
TRAIL INTERVAL	6M
TRAIL REF LVL	8
TRAIL SUPPRESS	0. ONM
TRAIL CLEAR	OFF
RANGE TRAIL	CLEAR



Display method

Press the [TRAILS] key in long mode

TRAILS	
TRAIL INTERVAL	6M
TRAIL REF LVL	8
TRAIL CLEAR	OFF
RANGE TRAIL	CLEAR

→ **TRAIL INTERVAL**

Sets a time interval of time trail.

→ **TRAIL REF LVL**

Sets a threshold value for determining whether trail information is stored.

→ **TRAIL SUPPRESS**

Sets the range for suppressing the trail from own ship.

→ **TRAIL CLEAR**

Clears the trail information from the memory.

→ **RANGE TRAIL**

Sets that trail information is not cleared even if the range is changed.

Menu by a direct key [DIMM] : Setting day/night mode and color and brightness of the selected screen

1st level

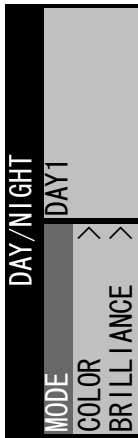

Display method

Press the [DIMM] key in lone mode.

2nd level

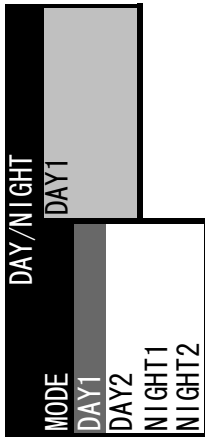

→ **DAY/NIGHT**

Select one of the four day/night modes.

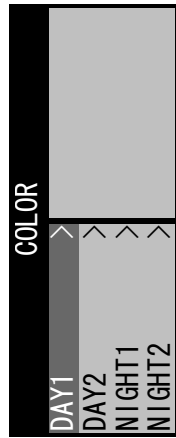

→ **COLOR (3rd and 4th levels available)**

Sets the color of the selected mode and screen.

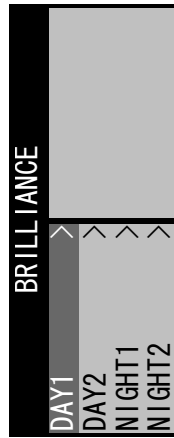

→ **BRILLIANCE (3rd and 4th levels available)**

Sets the brightness of the selected mode and screen.

Menu by a direct key [ALARM ACK] : Setting various alarm functions

1st level

ALARM	
BUZZER	>
ALARM	>
ERROR LOG	>
ERROR LOG CLR	>



Display method

Press the [ALARM ACK] key in long mode.

2nd level

BUZZER	
VOLUME	255
255	

ALARM	
ALARM ZONE	OFF
GUARD ZONE	>
ATA GUARD RING	

ERROR LOG	
BACK	1
CPA/TCPA	3
GZ	2
LOST	1
PRC-TRIGGER	
NEXT	

ALARM	
BUZZER	>
ERROR LOG CLR	
OFF	
ON	

→ **BUZZER**

Sets a buzzer volume.

→ **ALARM**

Sets various alarms. (3rd level available)

→ **ERROR LOG (several pages are available for the 2nd page)**

Displays various types of error log.

→ **ERROR LOG CLR**

Clears the error log.

Menu by a direct key [ATA] (1/3 pages) : Setting functions : **This menu is displayed at installation of the option only.**

1st level

ATA	
VECTOR	TRUE
VECTOR LENGTH	6.0MIN
CPA	0.0NM
CPA RING	OFF
TCPA	00MIN
INTERCEPT	OFF
TARGET NUMBER	ON
GATE SIZE	S

2nd level

ATA	
VECTOR	TRUE
RELATIVE	6.0MIN
TRUE	0.0NM
CPA RING	OFF
TCPA	00MIN
INTERCEPT	OFF
TARGET NUMBER	ON
GATE SIZE	S

→ VECTOR

Sets a vector.

→ VECTOR LENGTH

Sets a vector length.

→ CPA

Sets CPA.

ATA	
VECTOR	TRUE
VECTOR LENGTH	6.0MIN
6.0MIN	0.0NM
CPA RING	OFF
TCPA	00MIN
INTERCEPT	OFF
TARGET NUMBER	ON
GATE SIZE	S

ATA	
VECTOR	TRUE
VECTOR LENGTH	6.0MIN
CPA	0.0NM
0.0NM	OFF
TCPA	00MIN
INTERCEPT	OFF
TARGET NUMBER	ON
GATE SIZE	S

Menu by a direct key [ATA] (2/3 pages) : Setting functions : This menu is displayed at installation of the option only.

1st level

ATA	
VECTOR	TRUE
VECTOR LENGTH	6. 0MIN
CPA	0. 0NM
CPA RING	OFF
TCPA	00MIN
INTERCEPT	OFF
TARGET NUMBER	ON
GATE SIZE	S

2nd level

ATA	
VECTOR	TRUE
VECTOR LENGTH	6. 0MIN
CPA	0. 0NM
CPA RING	OFF
OFF	00MIN
ON	OFF
TARGET NUMBER	ON
GATE SIZE	S

→ CPA RING

Sets a CPA ring.

→ TCPA

Sets TCPA

→ INTERCEPT

ATA	
VECTOR	TRUE
VECTOR LENGTH	6. 0MIN
CPA	0. 0NM
CPA RING	OFF
TCPA	00MIN
INTERCEPT	OFF
OFF	ON
ON	S

Menu by a direct key [ATA] (3/3 pages) : Setting functions : **This menu is displayed at installation of the option only.**

1st level

ATA	
VECTOR	TRUE
VECTOR LENGTH	6.0MIN
CPA	0.0NM
CPA RING	OFF
TCPA	00MIN
INTERCEPT	OFF
TARGET NUMBER	ON
GATE SIZE	S

2nd level

ATA	
VECTOR	TRUE
VECTOR LENGTH	6.0MIN
CPA	0.0NM
CPA RING	OFF
TCPA	00MIN
TARGET NUMBER	OFF
OFF	ON
ON	S

→ **TARGET NUMBER**

Sets a display method of a target number.

ATA	
VECTOR	TRUE
VECTOR LENGTH	6.0MIN
CPA	0.0NM
CPA RING	OFF
GATE SIZE	00MIN
S	OFF
M	ON
L	S

→ **GATE SIZE**

Sets a tracking gate size.

Menu initialization by pressing a key at Power ON

1st level

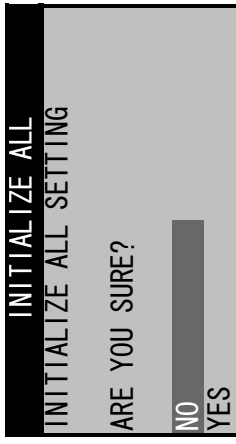

→ INITIALIZE ALL

Performs initialization operation.



Display method

Set the power to ON by pressing the [ACQ/ENT] key and [MENU] together.

Setting menu language by pressing a key at Power ON

1st level

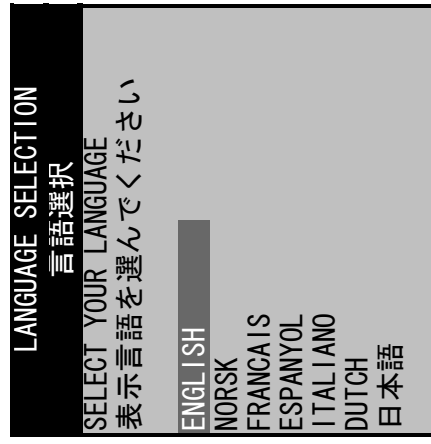

→ LANGUAGE SELECTION

Sets a language.



Display method

Set the power to ON by pressing the [DIMM] key.

Chapter 3 Operation Procedures

3.1 Operation Flow

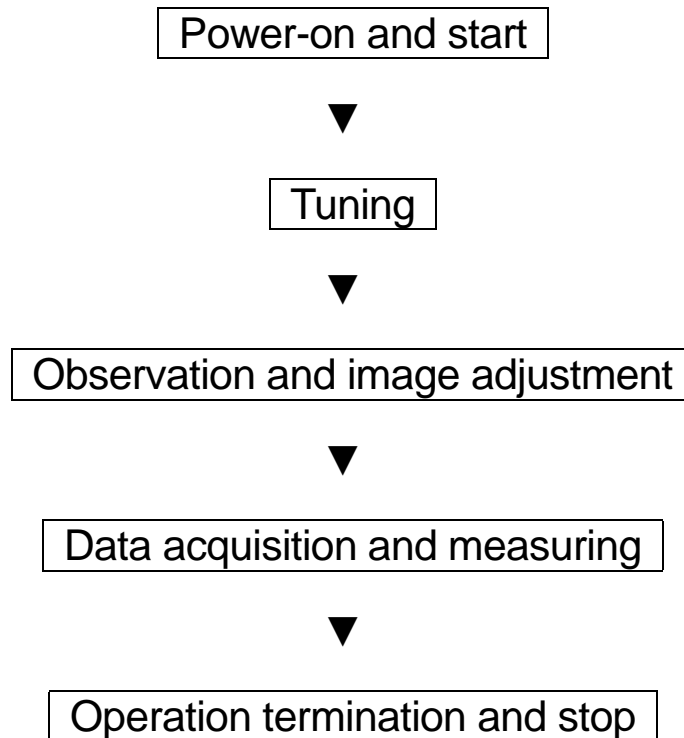

This chapter explains operations roughly divided into the following:

- **Power-on operation**
- **Basic operation**
- **General operation**
- **Function key operation**

Power-on operation must be set before this radar is turned on/off or the equipment is operated.

Basic operation is the minimum operation for operating the radar.

General operation is necessary for customizing the settings used with basic operation to best suit your needs or for using more useful functions.

Function key operation is necessary for storing the settings determined through general operation by the user or for implementing more advanced usage.

The following explains each basic operation:

3.2 Power-on Operation

3.2.1 Power-on and start

1. Turning on the power [STBY]

To turn on the power, press the **[STBY]** key.

When the power is turned on, the countdown timer is displayed on the screen, and the standby state is placed after 1 minute and 30 seconds.

The total duty time and total transmitting time are displayed. Refer to the time display when carrying out maintenance work. The time display includes a slight error.

2. Transmitting [TX/PRF]

To transmit data from the standby state, press the **[TX/PRF]** key.

To change the transmitting state back to the standby state, press the **[STBY]** key.

3.2.2 Tuning [AUTO-TUNE]

This radar can be tuned manually or automatically. To switch between manual tuning and automatic tuning, press the **[AUTO-TUNE]** control key. When automatic tuning is selected, "A" is displayed to the left of the tuning indicator at the right bottom of the screen.

1. Switching the tuning mode

If manual tuning is currently selected, pressing the **[AUTO-TUNE]** control key changes to automatic tuning. If automatic tuning is currently selected, pressing the key changes to manual tuning. The **automatic tuning mode** and **manual tuning mode** are switched back and forth each time the key is pressed.

2. Turning the tuning control [AUTO-TUNE]

If manual tuning is currently selected, enlarge the image by turning the tuning control on the keyboard. The tuning indicator serves as a rule of thumb for manual tuning. Adjust the image so that the pointer of the indicator reads the maximum value.

Automatic tuning does not need the turning of the tuning control.

If no image appears, turn the sensitivity control on the keyboard fully to the right, and turn the sea clutter control and the rain/snow clutter control fully to the left.

3.2.3 Observation and image adjustment [+RANGE-]

Display the optimum image by turning the tuning control (if manual tuning is selected), sensitivity control, sea clutter control, and rain/snow clutter control on the keyboard.

The image observation range can be changed by pressing the **[+RANGE-]** key.

The currently selected range is displayed at the upper left of the screen. (See 2.2, "Description of Screen Display.")

3.2.4 Data acquisition and measuring

For each operation, see 3.4, "Basic Operation" and Chapter 4, "Interpret the PPI Screen."

3.2.5 Operation termination and stop [STBY], [TX/PRF]

1. Canceling transmission [STBY]

Press the [STBY] key.

Transmission is canceled and the screen enters the standby state.

2. Turning off the power

Press the [STBY] key and [TX/PRF] key at the same time.

The radar enters the stopped state and all the functions stop.

WARNING



Before starting maintenance work or the like, stop power supply by turning off the power and disconnecting the power connector from the rectifier and the display. Even if the power switch is turned off, there are live components in each unit. In this status, maintenance or inspection work causes an electric shock, system failure, or accident.

3.3 Preparation for Observation

3.3.1 Changing the brightness of the LCD

- (a) Turning the BRILL control of the display clockwise increases the brightness. Turning it counterclockwise decreases the brightness. Use the BRILL control to change the brightness of the overall LCD.

3.3.2 Changing the brightness of the keyboard [DIMM]

- (a) Pressing the [DIMM] key changes the brightness of the keyboard.

Each time the [DIMM] key is pressed, the value indicating the brightness changes $1 \rightarrow 2 \rightarrow 3 \rightarrow 4 \dots 7 \rightarrow 8$, $8 \rightarrow 7 \rightarrow 6 \rightarrow \dots 2 \rightarrow 1$, $1 \rightarrow 2 \rightarrow 3$. As a greater value is selected, the brightness increases.

When the key is pressed again at the brightness level 8 or 1, the buzzer sounds indicating the maximum or minimum brightness.

Caution

- The brightness set by the [DIMM] key does not change even if the brightness is set to 0 by another switch.

3.3.3 Switching the display language [DIMM]

The following can be selected as a display language:

- Japanese
- English
- Norwegian
- French
- Spanish
- Italian
- Danish

- (a) Turn on the power while pressing the [DIMM] key. The menu below is displayed.
(Continue pressing the [DIMM] key until the following menu is displayed, since it will take about 10 seconds before the menu is displayed.)

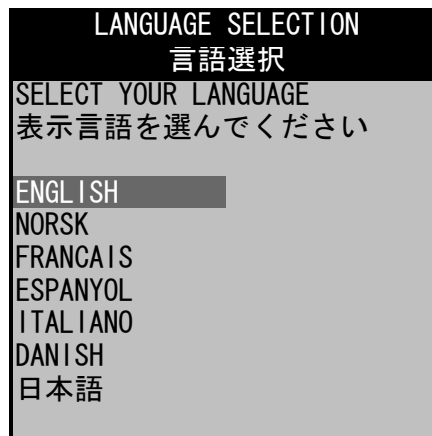

- (b) When the language selection menu is displayed, select the target language using **[JOG DIAL]**, and then press the **[JOG DIAL]** or **[ACQ/ENT]** key. The message is displayed asking if you want the selected language. If the selected language is the right one, press the **[JOG DIAL]** or **[ACQ/ENT]** key again. The system starts with the selected language.

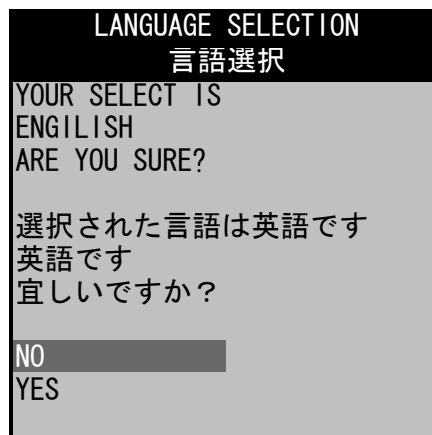

3.3.4 Setting the volume of the buzzer **[ALARM ACK]**

Set the volume of sound emitted when the key is pressed or an alarm is issued.

- Hold down the **[ALARM ACK]** key to display the **[ALARM]** menu.
- Select **[BUZZER]**, and then press the **[JOG DIAL]** or **[ACQ/ENT]** key.
- The menu below is displayed. Set a volume with a value 0 to 255 by turning **[JOG DIAL]**, and then press the **[JOG DIAL]** or **[ACQ/ENT]** key.

Caution

- Be careful that if the volume of the buzzer is set to 0 or a value not high enough, you may not hear the buzzer when an alarm is issued.

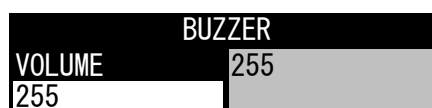

3.3.5 Switching the day/night mode [DIMM]

This radar permits the settings of four patterns of the screen brightness and display colors.

The four patterns are day 1, day 2, night 1, and night 2.

The switching of the above four patterns instantaneously selects the mode that can choose the screen brightness and display color.

Thus, this function enables more than one person to set the color and brightness according to their usage.

1. Switching the day/night mode [DIMM]

- Hold down the **[DIMM]** key to display the **DAY/NIGHT** menu.
- Operate **[JOG DIAL]** to select **MODE**, and then press the **[JOG DIAL]** or **[ACQ/ENT]** key.
- The menu below is displayed. Select the **DAY1**, **DAY2**, **NIGHT1**, or **NIGHT2** mode you want, and then press the **[JOG DIAL]** or **[ACQ/ENT]** key to determine the selection.

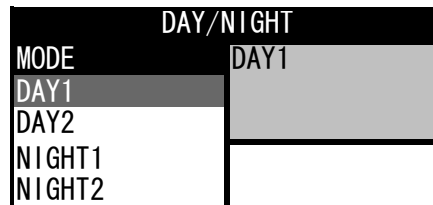

2. Switching the display color [DIMM]

The display color can be changed only for screens for which it is selectable.

The table below shows the screens for which a display color can be selected.

Color-selectable screens and display colors

Color-selectable screen	Color 1	Color 2	Color 3	Color 4
Background color inside PPI	BLACK	BLUE	GRAY	–
Background color outside PPI	BLACK	BLUE	GRAY	–
Color of echo	YELLOW	GREEN	ORANGE	COLOR
Color of timing trail	SKY	GREEN	WHTIE	–
Color of continuous trail	SKY	GREEN	WHTIE	–

Take the following steps to select the display color:

- Hold down the **[DIMM]** key to display the **DAY/NIGHT** menu.
- Operate **[JOG DIAL]** to select **COLOR**, and then press the **[JOG DIAL]** or **[ACQ/ENT]** key to determine the selection.
- Select the **DAY1**, **DAY2**, **NIGHT1**, or **NIGHT2** mode you want, and then press the **[JOG DIAL]** or **[ACQ/ENT]** key to determine the mode.
(This operation determines that the color of which pattern of the four is selected.)
- The left menu below is displayed. Select the **INSIDE**, **OUTSIDE**, **ECHO**, **TRAIL-TIME**, or **TRAIL-CONT** screen for which you want to set the color, and then press the **[JOG DIAL]** or **[ACQ/ENT]** key to determine the selection.

- (e) Subsequently, the right menu below is displayed. Operate **[JOG DIAL]** to select the color to be set, and then press the **[JOG DIAL]** or **[ACQ/ENT]** key to determine the selection.

DAY1	
INSIDE	BLUE
OUTSIDE	BLUE
ECHO	COLOR
TRAIL-TIME	BLUE
TRAIL-CONT	BLUE

DAY1	
INSIDE	BLUE
BLACK	BLUE
BLUE	COLOR
GRAY	BLUE
TRAIL-CONT	BLUE

3. Switching the brightness of the screen **[DIMM]**

The brightness of the screen can be changed only for screens for which it is selectable.

The brightness of the screen is selectable for ten screens of the five PPI system screens and five graphic system screens below.

PPI screens (related to radar images)

- <1> Background color inside PPI
- <2> Background color outside PPI
- <3> Echo
- <4> Timing trail
- <5> Continuous trail

Graphic screens (related to markers and symbols)

- <6> (SHM/cursor/WAYPOINT)
- <7> (EBL, VRM, fixed marker)
- <8> White symbol of MARPA
- <9> Red symbol of MARPA
- <10> Numeric value display

Take the following steps to change the display color:

- (a) Hold down the **[DIMM]** key to display the **DAY/NIGHT** menu.
- (b) Operate **[JOG DIAL]** to select **BRILLIANCE**, and then press the **[JOG DIAL]** or **[ACQ/ENT]** key to determine the selection.
- (c) Operate **[JOG DIAL]** to select the **DAY1**, **DAY2**, **NIGHT1**, or **NIGHT2** mode you want, and then press the **[JOG DIAL]** or **[ACQ/ENT]** key to determine the mode.
(This operation determines that the brightness of which pattern of the four is selected.)
- (d) The left menu below is displayed. Operate **[JOG DIAL]** to select one of the following screen on which you want to set the brightness, and then press the **[JOG DIAL]** or **[ACQ/ENT]** key:
INSIDE, **OUTSIDE**, **ECHO**, **TRAIL-TIME**, **TRAIL-CONT**,
HL/CURSOR/WPT, **EBL/VRM/RR**, **ATA WHITE**, **ATA RED**, **CHARACTER**,
and **PANEL DIMMER**
- (e) Finally, the right menu below is displayed. Operate **[JOG DIAL]** to select the value as the brightness to be set, and then press the **[JOG DIAL]** or **[ACQ/ENT]** key to determine the selection.

DAY1	
INSIDE	4
OUTSIDE	4
ECHO	4
TRAIL-TIME	4
TRAIL-CONT	4
HL/CURSOR/WPT	4
EBL/VRM/RR	4
ATA WHITE	4
ATA RED	4
CHARACTOR	4
PANEL DIMMER	8

DAY1	
INSIDE	4
4	4
ECHO	4
TRAIL-TIME	4
TRAIL-CONT	4
HL/CURSOR/WPT	4
EBL/VRM/RR	4
ATA WHITE	4
ATA RED	4
CHARACTOR	4
PANEL DIMMER	8

Note

Brightness can be set by the lowest line *PANEL DIMMER* of this menu as well as the description of 3.3.2 "Changing the brightness of the keyboard [DIMM]".

3.4 Basic Operation

3.4.1 Transmitting [TX/PRF]

- (a) Press the [TX/PRF] key.

The standby state is changed to the transmitting state.

3.4.2 Halting transmission [STBY]

- (a) Press the [STBY] key.

The transmitting state is changed to the standby state. The screen displays "STBY."

3.4.3 Changing the range [+RANGE-]

- (a) Press the [+RANGE-] key.

Pressing the key on the + side increases the range.

Pressing the key on the - side decreases the range.

3.4.4 Erasing/displaying the fixed range marker [RR/HL]

- (a) The fixed range marker is turned on/off each time the [RR/HL] key is pressed.

3.4.5 Erasing the ship's heading marker [RR/HL]

- (a) The ship's heading marker is not displayed while the [RR/HL] key is held down.

3.4.6 Tuning

See 3.2.2, "Tuning [AUTO-TUNE]."

3.4.7 Adjusting sensitivity [GAIN/PL]

- (a) Sensitivity adjustment ([GAIN/PL] control) is not necessary for general use.

The [GAIN/PL] control is always set to the maximum (turned fully to the right).

However, if many noises appear on the screen, turn the [GAIN/PL] control to set sensitivity for easy observation.

Caution

- If the set sensitivity is too low, the target of a dangerous object or ship may not be displayed.
- In some cases, if the set sensitivity is too high, the receiver noise on the radar screen increases and interferes with the observation.

3.5 General Operation

3.5.1 Eliminating radar interference [MENU]

If radar interference occurs, take the following steps to set an interference elimination level:

- Press the **[MENU]** key to display **[MENU]**.
- Select **[BASIC]** and then **[INTERFERENCE]** pressing the **[JOG DIAL]** or **[ACQ/ENT]** key after each selection.
- The menu below is displayed. Select **[OFF]**, **[IR1]**, **[IR2]**, or **[IR3]**, and then press the **[JOG DIAL]** or **[ACQ/ENT]** key to determine the selection.

BASIC	
INTERFERENCE	IR1
OFF	OFF
IR1	OFF
IR2	3.0
IR3	FULL
ZOOM	OFF

Note

The interference elimination levels are **[IR1]** → **[IR2]** → **[IR3]** starting with the lowest level. However, if the set level is too high, a problem such as the decrease of sensitivity occurs. The lowest level **[IR1]** should be selected for general use.

3.5.2 When it is raining or snowing [AUTO-RAIN]

CAUTION



Do not set the rain/snow clutter function to too high a suppression level. Otherwise, not only echoes from rain/snow but also the targets of ships or dangerous objects are suppressed, which may disturb the detection. Set the best suppression level whenever you use the rain/snow clutter suppression function.

When it rains or snows, echoes (rain clutters) from rain or snow are displayed on the PPI screen. As a result, the images of echoes from ships or the likes are difficult to observe.

Use of the manual or automatic rain/snow clutter function suppresses rain clutters and makes it easy to observe targets.

While the automatic rain/snow clutter function is working, the manual rain/snow clutter function (control) cannot be used.

To select the manual or automatic rain/snow clutter function of this radar, operate the **[AUTO-RAIN]** control. When the automatic rain/snow clutter suppression function is ON, "A RAIN" is displayed on the upper right of the screen.

(a) Switching the rain/snow clutter suppression mode

If manual rain/snow clutter suppression is currently selected, pressing the **[AUTO-RAIN]** control key changes to automatic rain/snow clutter suppression. If auto rain/snow clutter suppression is currently selected, pressing the **[AUTO-RAIN]** control key changes to manual rain/snow clutter suppression. **The automatic rain/snow clutter suppression mode and manual rain/snow clutter suppression mode** are switched back and forth each time the key is pressed.

(b) Turning the rain/snow clutter control

If manual rain/snow clutter suppression is currently selected, as the rain/snow clutter control is turned clockwise, the rain/snow clutter suppression function works more strongly.

3.5.3 When the sea is rough [AUTO-SEA]

CAUTION



Do not set the sea clutter suppression function to a level at which it clears all sea clutters in short range. Otherwise, not only echoes from waves but also the targets of ships or dangerous objects are suppressed, which may disturb the detection. Set the best suppression level whenever you use the sea clutter suppression function.

If the sea becomes rough, echoes (sea clutters) from waves are displayed on the PPI screen. As a result, the images of echoes from ships or the likes are difficult to view. Sea clutters appear more clearly in shorter ranges.

Use of the manual or automatic sea clutter function suppresses sea clutters and makes it easy to observe targets.

While the automatic sea clutter function is working, the manual rain/snow clutter function (control) cannot be used.

To select the manual or automatic rain/snow clutter function of this radar, operate the **[AUTO-SEA]** control. When the automatic sea clutter suppression function is ON, "A SEA" is displayed on the upper right of the screen.

(a) Switching the sea clutter suppression mode

If manual sea clutter suppression is currently selected, pressing the **[AUTO-SEA]** control key changes to automatic sea clutter suppression. If auto sea clutter suppression is currently selected, pressing the **[AUTO-SEA]** control key changes to manual sea clutter suppression.

The automatic sea clutter suppression mode and manual sea clutter suppression mode are switched back and forth each time the key is pressed.

(b) Turning the sea clutter control

If manual sea clutter suppression is currently selected, as the sea clutter control is turned clockwise, the sea clutter suppression function works more strongly.

3.5.4 Using the trackball [TRACK BALL]

[TRACK BALL] enables you to easily measure a distance to a target and the bearing at the same time.

Operate [TRACK BALL] to position the cursor to the target. The distance to the target and the bearing are displayed at the right bottom of the screen.

If a navigator such as a GPS is connected, the latitude and longitude at the target position can also be displayed.

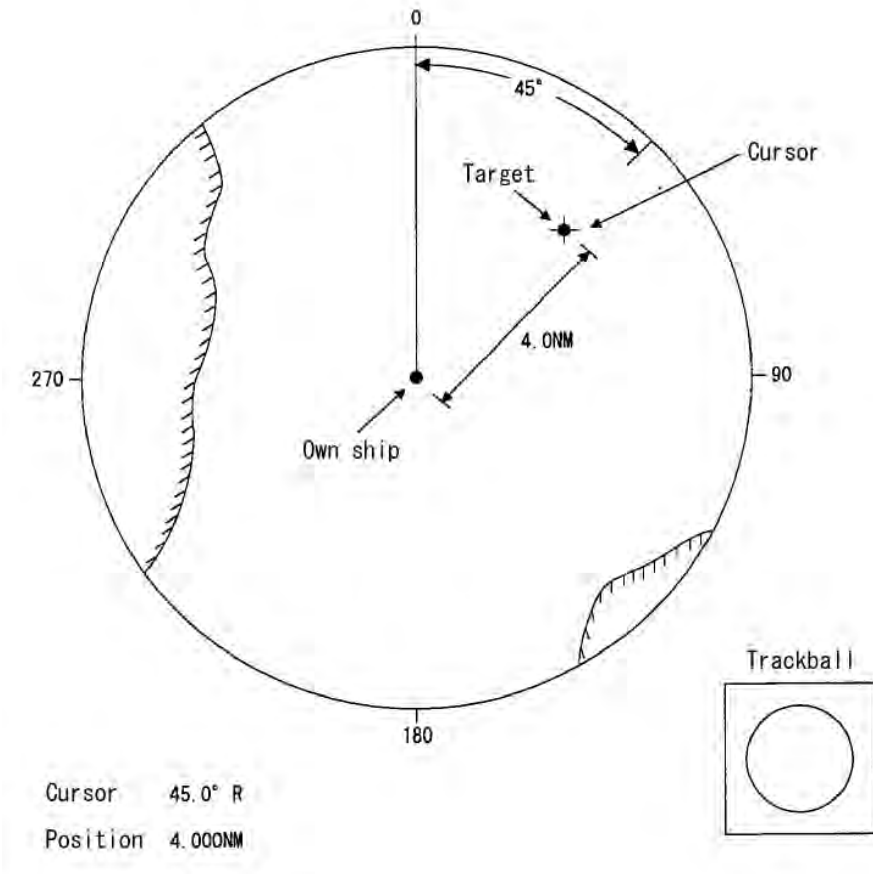

In this case, the target is at a position 4 NM from the own ship.

3.5.5 Using VRM [VRM1/VRM2], [JOG DIAL]

VRM is a line for measuring a distance to the target that is displayed on the PPI screen.

Since the size of the circle of VRM can be changed freely through [JOG DIAL], a distance to an arbitrary target can be measured.

This radar can display 2 VRMs (VRM#1 and VRM#2) concurrently.

To display, select, or erase VRM#1/VRM#2, use the [VRM1/VRM2] key.

The VRM status is as follows:

Neither **VRM#1** nor **VRM#2** is displayed.

VRM#1 is displayed, and **VRM#2** is not displayed.

VRM#2 is displayed, and **VRM#1** is not displayed.

Both **VRM#1** and **VRM#2** are displayed.

Use the following methods to select each state above:

How to operate the [VRM1/VRM2] key

Use the [VRM1/VRM2] key to switch between VRM#1 and VRM#2 and turn ON/OFF VRM#1/VRM#2.

1. Selecting VRM#1/VRM#2 [VRM1/VRM2]

If neither VRM#1 nor VRM#2 is displayed, VRM#1 or VRM#2 can be selected/displayed by pressing the [VRM1/VRM2] key.

If both VRM#1 and VRM#2 are displayed, VRM#1 and VRM#2 are selected back and forth by holding down the [VRM1/VRM2] key.

The currently operable VRM#1/VRM#2 is shown with the VRM value reversed enclosed in broken lines at the upper right of the screen.

2. Operating VRM#1/VRM#2 [VRM1/VRM2]

The VRM specified in 1 is operable.

After specifying the VRM you want to operate in 1, press [JOG DIAL] several times until the jog dial mode display at the right bottom of the screen changes to "JOG VRM."

[JOG DIAL] enters the VRM operation mode.

In this status, the VRM can be zoomed in/out.

Turning [JOG DIAL] clockwise "zooms in" the VRM.

Turning [JOG DIAL] counterclockwise "zooms out" the VRM.

3. Erasing VRM#1/VRM#2 [VRM1/VRM2]

If both VRM#1 and VRM#2 are displayed, press the [VRM] key to reverse the value of VRM#1/VRM#2 you want to retain on the screen. In this status, pressing the [VRM1/VRM2] key erases the non-reversed VRM.

If only VRM#1 or VRM#2 is displayed, press the [VRM] key to reverse the value of VRM#1/VRM#2. It is enclosed in broken lines.

In this status, pressing the [VRM1/VRM2] key erases the non-reversed VRM.

4. Measuring the distance from own ship using VRM#1 [VRM1/VRM2]

- Press the [VRM1/VRM2] key to reverse the value of VRM#1.
- Press [JOG DIAL] several times until the jog dial mode display at the right bottom of the screen changes to "JOG VRM1."
- In this status, turn [JOG DIAL] to adjust the line of VRM#1 to the target, and read the value of VRM#1 to measure the distance to the target.

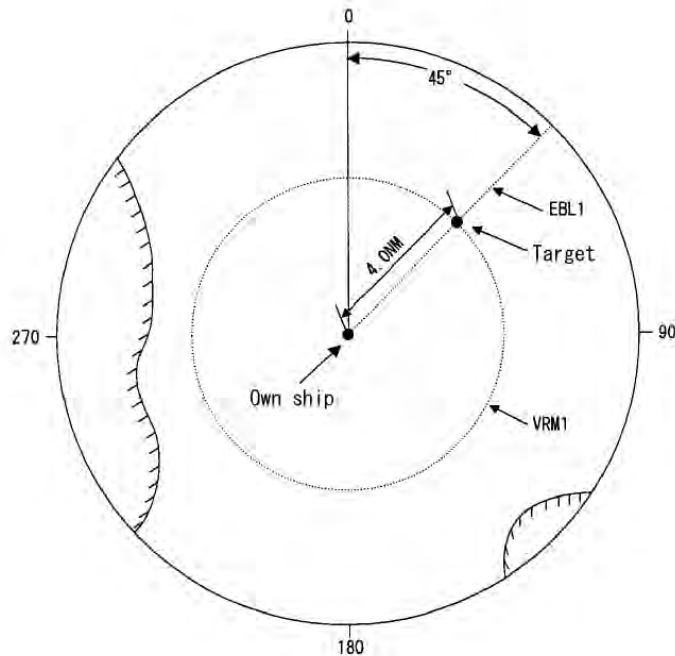

In the figure above, the distance from the own ship to the target is 4 NM.

5. Measuring the distance from own ship using VRM#2 [VRM1/VRM2]

- Press the [VRM1/VRM2] key to reverse the value of VRM#2.
- Press [JOG DIAL] several times until the jog dial mode display at the right bottom of the screen changes to "JOG VRM2."
- In this status, turn [JOG DIAL] to adjust the line of VRM#2 to the target, and read the value of VRM#2 to measure the distance to the target.

Caution

- If EBL2 is in floating EBL mode, the center of VRM2 is the fulcrum of EBL2.

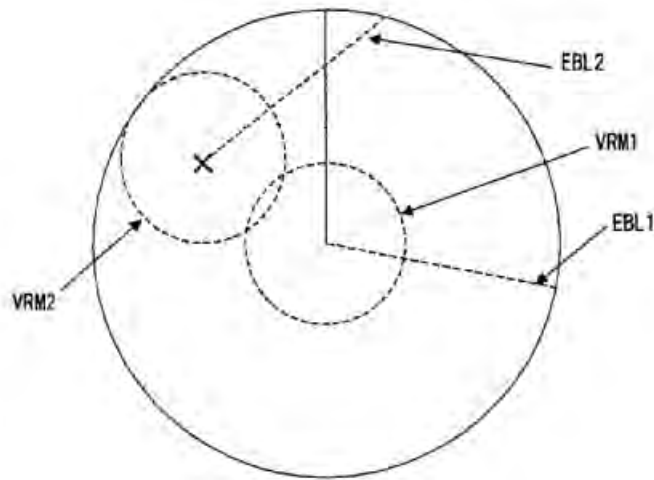

VRM2 display with EBL2 in floating EBL mode

6. Setting KM as range units

The range units of VRM1 or VRM2 can be switched to KM or NM.

The range units can be set for VRM1 and VRM2 separately.

The units "KM" or "NM" is displayed following VRM1/VRM2.

Take the following steps to select the range units of VRM:

- Press the **[MENU]** key to display **[MENU]**.
- Select **[DISP OPTIONS]** and then **[VRM1 UNITS]** or **[VRM2 UNITS]** pressing the **[JOG DIAL]** or **[ACQ/ENT]** key after each selection.
- The menu below is displayed. Turn **[JOG DIAL]** to select **[KM]** or **[NM]**, and then press the **[JOG DIAL]** or **[ACQ/ENT]** key to determine the selection.

DISP OPTIONS	
EBL BEARING	TRUE
FROATING EBL	OFF
PARALLEL LINE	OFF
VRM1 UNITS	NM
VRM2 UNITS	NM
NM	OFF
KM	LL
LL-TD CONV>	

Setting of the units of VRM2

3.5.6 Using EBL (electronic bearing cursor) [EBL1/EBL2], [TRACK BALL]

EBL (electronic bearing cursor) is a line for measuring the bearing of the target that is displayed on the PPI screen.

Since the angle of the line of EBL can be changed freely through [JOG DIAL], the bearing of an arbitrary target can be measured.

This radar can display 2 EBLs (EBL#1 and EBL#2) concurrently.

To display, select, or erase EBL#1/EBL#2, use the [EBL1/EBL2] key.

EBL is displayed on the right side of the screen (horizontal display), or it is displayed in the numeric value display area at the bottom of the screen (vertical display). Operable EBL1 or EBL2 is reversed.

The EBL status is as follows:

Neither **EBL#1** nor **EBL#2** is displayed.

EBL#1 is displayed, and **EBL#2** is not displayed.

EBL#2 is displayed, and **EBL#1** is not displayed.

Both **EBL#1** and **EBL#2** are displayed.

Use the following methods to select each state above:

How to operate the [EBL1/EBL2] key

Use the [EBL1/EBL2] key to switch between EBL#1 and EBL#2 and turn ON/OFF EBL#1/EBL#2.

1. Selecting EBL#1/EBL#2 [EBL1/EBL2]

If neither EBL#1 nor EBL#2 is displayed, EBL#1 or EBL#2 can be selected/displayed by pressing the [EBL1/EBL2] key.

If both EBL#1 and EBL#2 are displayed, EBL#1 and EBL#2 are selected back and forth by holding down the [EBL1/EBL2] key.

The currently operable EBL#1/EBL#2 is shown with the EBL value reversed enclosed in broken lines at the upper right of the screen.

2. Operating EBL#1/EBL#2 [EBL1/EBL2]

The EBL specified in 1 is operable.

After specifying the EBL you want to operate in 1, press [JOG DIAL] several times until the jog dial mode display at the right bottom of the screen changes to "JOG EBL."

[JOG DIAL] enters the EBL operation mode.

In this status, the EBL can be turned.

Turning [JOG DIAL] clockwise turns the EBL "clockwise."

Turning [JOG DIAL] counterclockwise turns the EBL "counterclockwise."

3. Erasing EBL#1/EBL#2 [EBL]

If both EBL#1 and EBL#2 are displayed, press the [EBL] key to reverse the value of EBL#1/EBL#2 you want to retain on the screen. In this status, pressing the [EBL1/EBL2] key erases the non-reversed EBL.

If only EBL#1 or EBL#2 is displayed, press the **[EBL]** key to reverse the value of EBL#1/EBL#2.

In this status, pressing the **[EBL1/EBL2]** key erases the non-reversed EBL.

4. Measuring the bearing from own ship using EBL#1 [EBL1/EBL2]

- Press the **[EBL1/EBL2]** key to reverse the value of EBL#1.
- Press the **[JOG DIAL]** control several times until the jog dial mode display at the right bottom of the screen changes to **"JOG EBL1."**
- In this status, turn **[JOG DIAL]** to adjust the line of EBL#1 to the target, and read the value of EBL#1 to measure the bearing to the target.

5. Measuring the bearing from own ship using EBL#2 [EBL1/EBL2]

- Press the **[EBL1/EBL2]** key to reverse the value of EBL#2.
- Press the **[JOG DIAL]** control several times until the jog dial mode display at the right bottom of the screen changes to **"JOG EBL2."**
- In this status, turn **[JOG DIAL]** to adjust the line of EBL#2 to the target, and read the value of EBL#2 to measure the bearing to the target.

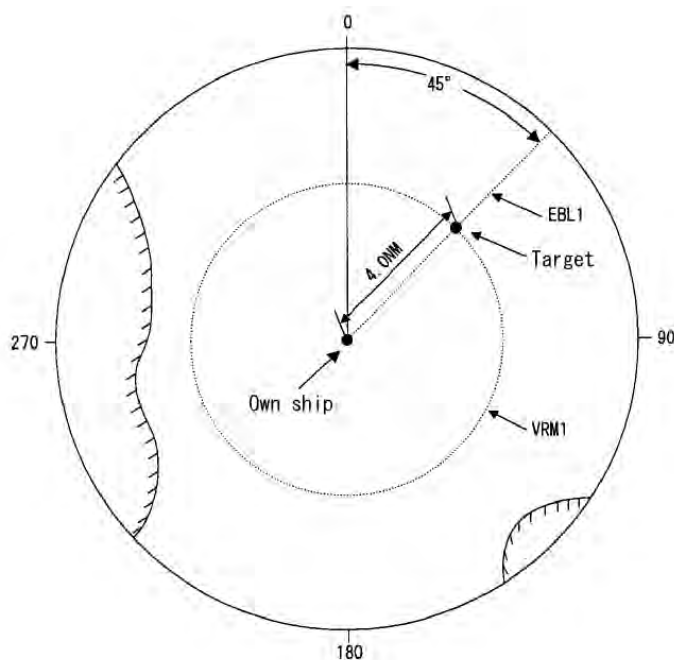

In this case, the target is at a position of the relative bearing 45 degrees from the own ship.

6. Using EBL2 as a floating EBL

EBL2 can be used as a floating EBL (eccentric EBL).

Take the following steps to place EBL2 in floating EBL mode.

- Operate **[TACK BALL]** to determine the fulcrum of EBL2.
- Press the **[MENU]** key to display **[MENU]**.
- Select **[DISP OPTIONS]** and then **[FLOATING EBL]** pressing the **[JOG DIAL]** or **[ACQ/ENT]** key after each selection.

- (d) The menu below is displayed. Turn **[JOG DIAL]** to select **[ON]**, and then press the **[JOG DIAL]** or **[ACQ/ENT]** key to determine the selection.

DISP OPTIONS	
EBL BEARING	TRUE
FROATING EBL	OFF
OFF	OFF
ON	NM
VRM2 UNITS	NM
WAYPOINT	OFF
POSITION	LL
LL-TD CONV>	

As shown in the figure below, EBL2 moves to the cursor position. If VRM2 is displayed at the same time, the center of VRM2 also moves to the fulcrum of EBL2.

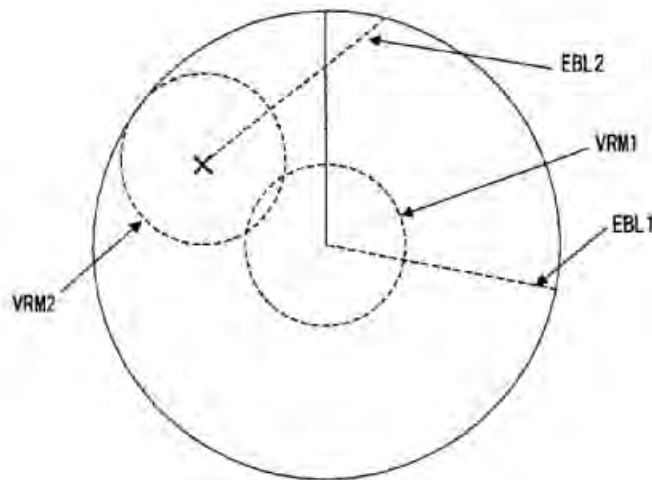

With EBL2 being placed in floating EBL mode

7. Setting EBL display

EBL can select true bearing or relative bearing.

True bearing means that the EBL bearing viewed from the own ship indicates the absolute bearing on the earth.

Relative bearing means that the EBL bearing viewed from the own ship indicates the relative bearing between the own ship and EBL.

Caution

- True bearing and relative bearing are switched for both EBL1 and EBL2. Thus, they cannot be set for EBL1 and EBL2 separately.

If true bearing presentation is selected, the value of EBL is displayed following by "T." If relative bearing presentation is selected, the value of EBL is displayed following by "R."

Take the following steps to switch between the relative bearing and true bearing of EBL:

- (a) Press the **[MENU]** key to display **MENU**.
- (b) Select **DISP OPTIONS** and then **EBL BEARING** pressing the **[JOG DIAL]** or **[ACQ/ENT]** key after each selection.
- (c) The menu below is displayed. Turn **[JOG DIAL]** to select **RELATIVE** or **TRUE**, and then press the **[JOG DIAL]** or **[ACQ/ENT]** key to determine the selection.

DISP OPTIONS	
EBL BEARING	TRUE
RELATIVE	OFF
TRUE	OFF
VRM1 UNITS	NM
VRM2 UNITS	NM
WAYPOINT	OFF
POSITION	LL
LL-TD CONV>	

3.5.7 Changing the bearing presentation method of the PPI screen [AZI MODE]

The following three bearing presentation methods are available for the radar PPI screen:

(a) Relative bearing presentation (Head Up)

Relative bearing is presented with the heading just above (at 0° of bearing marker) the PPI screen.

When the ship's heading changes, the bearing of the echo image on the PPI screen also changes.

If bearing information cannot be received from a navigator such as a gyrocompass, this relative bearing presentation is applied.

To place the screen in Head Up mode, press the **[AZI MODE]** key on the keyboard several times until the display at the upper left of the screen changes to "HUP."

(b) True bearing presentation (North Up)

True bearing is presented with "North" as due north of the PPI screen.

Even if the ship's heading changes, the bearing of the echo image on the PPI screen does not change.

(A device such as a gyrocompass is necessary for getting bearing information.)

To place the screen in North Up mode, press the **[AZI MODE]** key on the keyboard several times until the display at the upper left of the screen changes to "NUP."

(c) Course Up [AZI MODE]

The ship's heading at time of setting Course Up mode is presented with right above (at 0° of bearing marker) of the PPI screen.

When own ship's course changes after setting as Course Up mode, the bearing of the echo image on the PPI screen does not change and the ship's heading marker turns by only the change of the ship's heading.

When the course greatly changes, hold down the **[AZI MODE]** key to set the course again. (Course up reset)

To place the screen in Course Up mode, press the **[AZI MODE]** key on the keyboard several times until the display at the upper left of the screen changes to "CUP."

Caution

- **Course up reset is only available in Course Up mode.**
Hold down the **[AZI MODE]** key except course reset mode, the mode is shifted to gyro setting mode.

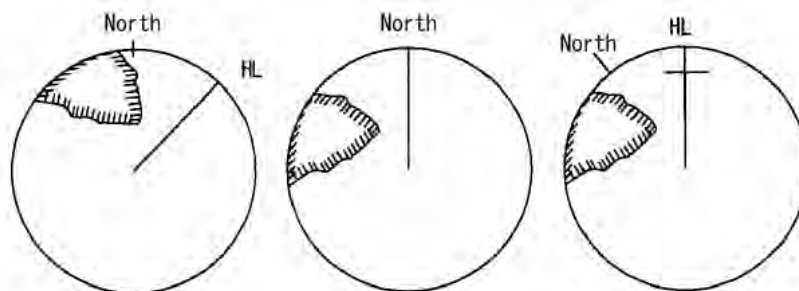

Display in North Up mode Display in Head Up mode Display in Course Up mode

- **The input of bearing information from the navigator is necessary for changing the bearing presentation method of the PPI screen.**

3.5.8 Changing the center of the PPI screen **[OFFCENT]**

A display in an arbitrary direction can be lengthened by moving the center (off center) of the PPI screen.

1. Setting a position to which the center is moved

- Move the cursor to the position where you want to move the center of the screen.
- Press the **[OFFCENT]** key. The center of the PPI screen moves to the new position.

2. Canceling the position as the new center

- To return the center of the screen to the original, press the **[OFFCENT]** key again. The center of the screen returns to the original.

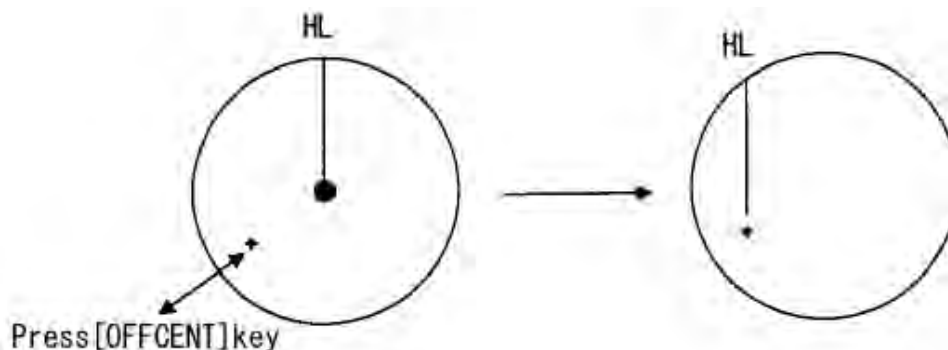

Note

Even if the center of the PPI screen is moved, this radar does not erase the images on the PPI screen including the display of trails and the likes.

You can observe the heading of another ship at any time by freely moving the center of PPI screen.

Caution

- The center of the PPI screen can be moved by up to 90% of the maximum screen radius. If the center is moved by the allowable maximum into the SHM direction, the observable range of targets in the heading direction becomes too small, which is dangerous.

The center of the screen should be moved into the SHM direction for short observation such as confirmation of another ship's position.

3. Continuously moving the center

To continuously move the center of the PPI screen, operate **[TRACK BALL]** while pressing the **[OFFCENT]** key. When deciding a position as the new center, release the **[OFFCENT]** key. Moving of the center stops.

4. Canceling the position as the new center

To return the center of the screen to the original, press the **[OFFCENT]** key again. The center of the screen returns to the original.

3.5.9 Using the trail display function **[TRAILS]**

Displaying radar trails

The heading of another ship can be confirmed by the trail length and direction. This feature assists in avoiding ship collision.

Timing trail display, continuous trail display, or combination of timing trail display and continuous trail display can be selected for the trail length of the radar.

- Timing trail display :

A value 30 to 59 seconds or 1 to 59 minutes can be set for the trail length.

- Continuous trail display :

The trail length is unlimited.

- Timing trail display + continuous trail display :

The trail length is set in combination of the two modes above.

Even while the trail display function is set to OFF, the trail storage function is always working. Thus, you can display trail data through one-touch operation whenever you want to.

1. Setting the trail display function to ON/OFF **[TRAILS]**

- (a) Press the **[TRAILS]** key. The display changes in the following sequence:

Display OFF → display ON (timing trail display) → display ON (continuous trail display)
→ display ON (timing trail display + continuous trail display) → display OFF.

2. Setting a trail interval [TRAILS]

- Hold down the [TRAILS] key to display the TRAILS menu.
- Operate [JOG DIAL] to select TRAIL INTERVAL, and then press the [JOG DIAL] or [ACQ/ENT] key.
- The menu below is displayed. Turn [JOG DIAL] to set a value 30 to 59 seconds or 1 to 99 minutes, and then press the [JOG DIAL] or [ACQ/ENT] key to determine the setting.

TRAILS	
TRAIL INTERVAL	6M
TRAIL REF LVL	8
TRAIL SUPPRESS	0. ONM
TRAIL CLEAR	OFF
RANGE TRAIL	CLEAR

TRAILS	
TRAIL INTERVAL	6M
6NM	8
TRAIL SUPPRESS	0. ONM
TRAIL CLEAR	OFF
RANGE TRAIL	CLEAR

Caution

- Because wake time may err by the rotation speed of scanner unit or the setting timing, surely use this as a standard.

3. Clearing stored trail data [TRAILS]

- Hold down the [TRAILS] key to display the TRAILS menu.
- Operate [JOG DIAL] to select TRAIL CLEAR, and then press the [JOG DIAL] or [ACQ/ENT] key.
- Select ON, and then press the [JOG DIAL] or [ACQ/ENT] key to determine the selection.

TRAILS	
TRAIL INTERVAL	6M
TRAIL REF LVL	8
TRAIL SUPPRESS	0. ONM
TRAIL CLEAR	OFF
RANGE TRAIL	CLEAR

TRAILS	
TRAIL INTERVAL	6M
TRAIL REF LVL	8
TRAIL CLEAR	0. ONM
OFF	OFF
ON	CLEAR

- The ON selected above is automatically changed back to OFF when the stored trail data has been cleared.

4. Setting a trail reference level (trail threshold) [TRAILS]

A trail reference level is used to determine whether to store trail data depending on the strength of targets.

A level 0 to 15 can be set as a threshold.

When level 1 is set, the data of all the targets displayed on the PPI screen is stored/displayed.

As a higher level is set, the trail data of only stronger targets is stored/displayed.

Level 8 is usually set.

If sea clutters are strong and they are also stored/displayed, set a level higher than 8.

Conversely, if the trail data of weak targets is difficult to store/display, set a level lower than 8.

Take the following steps to set a trail reference level (trail threshold):

- (a) Hold down the **[TRAILS]** key to display the TRAILS menu.
- (b) Operate **[JOG DIAL]** to select TRAIL REF LVL, and then press the **[JOG DIAL]** or **[ACQ/ENT]** key.
- (c) The menu below is displayed. Select the threshold (level) you want to set, and then press the **[JOG DIAL]** or **[ACQ/ENT]** key to determine the selection.

TRAILS	
TRAIL INTERVAL	6M
TRAIL REF LVL	8
8	0. ONM
TRAIL CLEAR	OFF
RANGE TRAIL	CLEAR

5. Setting a trail storage suppression distance **[TRAILS]**

The trail storage suppression distance is a function not to store the data of trails in a specified distance from the own ship.

Use the function not to store the data of unnecessary trails due to wave splash when the own ship sails.

To turn OFF the storage suppression function, set "0" in the procedure below.

Take the following steps to set a trail storage suppression distance:

- (a) Hold down the **[TRAILS]** key to display the TRAILS menu.
- (b) Operate **[JOG DIAL]** to select TRAIL SUPRESS, and then press the **[JOG DIAL]** or **[ACQ/ENT]** key.
- (c) The menu below is displayed. Turn **[JOG DIAL]** to set a distance from the own ship in which you do not want to store trail data, and then press the **[JOG DIAL]** or **[ACQ/ENT]** key to determine the setting.

TRAILS	
TRAIL INTERVAL	6M
TRAIL REF LVL	8
TRAIL SUPRESS	0. ONM
0. ONM	OFF
RANGE TRAIL	CLEAR

6. Setting a range trail storage **[TRAILS]**

The range trail storage is a function not to clear the trail storage in temporarily observing a range other than the present range at the time of the trail storage or the trail display.

Normal setting value is "CLEAR", and the trail is automatically cleared by switched the range.

The trail is not automatically cleared even if the range is switched, set "KEEP" in the procedure below.

Take the following steps to set a range trail storage:

- (a) Hold down the **[TRAILS]** key to display the TRAILS menu.
- (b) Operate **[JOG DIAL]** to select RANGE TRAIL, and then press the **[JOG DIAL]** or **[ACQ/ENT]** key.
- (c) The menu below is displayed. Turn **[JOG DIAL]** to select KEEP, and then press the **[JOG DIAL]** or **[ACQ/ENT]** key to determine the selection.

TRAILS	
TRAIL INTERVAL	6M
TRAIL REF LVL	8
RANGE TRAIL	0. ONM
CLEAR	OFF
KEEP	CLEAR

3.5.10 Using the target expansion function [MENU]

The image expansion function extends the images of echoes on the PPI screen into the angle direction and distance direction.

Caution

- When the image expansion function is used, the echoes of two targets that are close to each other in the distance direction (ahead/behind) and angle direction may turn into a single image on the PPI screen.

1. Setting the target expansion function

Take the following steps to set the target expansion function:

- Press the [MENU] key to display .
- Select and then pressing the [JOG DIAL] or [ACQ/ENT] key after each selection.
- The menu below is displayed. Turn [JOG DIAL] to select , and then press the [JOG DIAL] or [ACQ/ENT] key to determine the selection.

2. Canceling the target expansion function

To cancel the target expansion function, take the above steps changing step (c) as follows:

- In step (c) above, select , and then press the [JOG DIAL] or [ACQ/ENT] key to determine the selection.

3.5.11 Changing the transmitter pulse length [GAIN/PL]

The transmitter pulse length can be changed in the range of 1.5, 3, or 6 nautical miles.

If a long pulse is selected, the images of echoes on the PPI screen are lengthened in the distance direction. Conversely, if a short pulse is selected, the images are displayed reduced in size (length).

Unlike the image expansion function, the above function displays the echoes when a pulse becomes longer that have not been displayed previously.

Caution

- When a longer pulse is selected, the echoes of two targets that are close to each other in the distance direction (ahead/behind) may turn into a single image on the PPI screen.

Changing the pulse length

- (a) Press the **[GAIN/PL]** control during transmission. The pulse length display at the right bottom of the screen changes. At the same time, the pulse length changes, and the size of the echoes on the screen changes.

3.5.12 Using the zoom function [MENU]

The zoom function can double the size of the PPI screen on the basis of own ship position.

Caution

- This function does not work when the 0.125 nautical mile range is used.

1. Setting the zoom function

Take the following steps to zoom the area:

- (a) Press the **[MENU]** key to display **[MENU]**.
- (b) Select **[BASIC]** and then **[ZOOM]** pressing the **[JOG DIAL]** or **[ACQ/ENT]** key after each selection.
- (c) The menu below is displayed. Turn **[JOG DIAL]** to select **[ON]**, and then press the **[JOG DIAL]** or **[ACQ/ENT]** key to determine the selection.

BASIC	
INTERFERENCE	IR1
TGT EXPANSION	OFF
PROCESS	OFF
ZOOM	3.0
OFF	FULL
ON	OFF

- The center of the PPI can be moved to a position of 90% of the observation range.

- (e) The area is doubled with own ship as the center.

2. Canceling the zoom function

In step (d) above, select **[OFF]**, and then press the **[JOG DIAL]** or **[ACQ/ENT]** key. The zoom function is canceled and the screen returns to the normal display.

3.5.13 Highlighting a target by decreasing unnecessary noise (image processing) [MENU]

Caution

- Do not use this function to view the radar beacon, the START signal, or a target moving at a high speed on the radar screen.
- This function is used most suitably in TM mode.
When you use the function in RM mode, select N-UP or C-UP. Use of the function with H-UP may cause images to be blurred.

1. Setting image processing [MENU]

There are three types of image processing, PROC1, PROC2, and PROC3.

PROC1: Select PROC1 when there is a target moving at a low speed.

The image of a relatively unstable target is highlighted and displayed in stable state.

PROC1 is effective for suppressing irregular signals like sea clutters.

However, the image of a target moving at a high speed dims.

Use PROC1 in a range of 1.5 nautical miles or less as a rule of thumb.

PROC2: Select PROC2 to display images in more stable state than "PROC1" does.

PROC2 is effective particularly when there are many sea clutters.

Use PROC2 in a range of 3 nautical miles or more as a rule of thumb.

PROC3: Select PROC3 when a target is not displayed at the very limit of remote noise.

Use PROC3 in a range of 6 nautical miles or more as a rule of thumb.

Disadvantage of PROC3 is that the target may be more difficult to observe because noise or the like also appears clearly.

PROC1+3: PROC1 is performed in a preset processing range (the processing range from own ship), and PROC3 is performed outside the processing range (the processing range or more).

Use PROC1+3 as navigation when you want to display a target at the very limit of remote noise while performing PROC1 that makes it easy to observe other ships influenced by sea clutters in short range.

PROC2+3: PROC2 is performed in a preset processing range (the processing range from own ship), and PROC3 is performed outside the processing range (the processing range or more).

Use PROC2+3 as navigation when you want to display a target at the very limit of remote noise while performing PROC2 that makes it easier to observe other ships influenced by sea clutters in short range than PROC1 does.

Take the following steps to set image processing:

- Press the [MENU] key to display [MENU].
- Select [BASIC] and then [PROCESS] pressing the [JOG DIAL] or [ACQ/ENT] key after each selection.

- (c) The menu below is displayed. Turn **[JOG DIAL]** to select **PROC1**, **PROC2**, **PROC3**, **PROC1+3**, or **PROC2+3**, and then press the **[JOG DIAL]** or **[ACQ/ENT]** key to determine the selection.

BASIC	
PROCESS	IR1
OFF	OFF
PROC1	OFF
PROC2	3.0
PROC3	FULL
PROC1+3	OFF
PROC2+3	

2. Canceling image processing [MENU]

In step (c) above, select **OFF** to cancel the image processing function.

3. Setting an image processing range [MENU]

Take the following steps to select the processing range of PROC1+3 or PROC2+3:

- (a) Press the **[MENU]** key to display **MENU**.
- (b) Select **BASIC** and then **PROC SW RANGE** pressing the **[JOG DIAL]** or **[ACQ/ENT]** key after each selection.

The menu below is displayed. Turn **[JOG DIAL]** to set the range you want, and then press the **[JOG DIAL]** or **[ACQ/ENT]** key to determine the setting.

BASIC	
INTERFERENCE	IR1
TGT EXPANSION	OFF
PROCESS	OFF
PROC SW RANGE	3.0
3.0NM	FULL
ZOOM	OFF

3.5.14 Switching true/relative motion display [TM/RM]

The motion mode determines whether to display the moving of the own ship and another target in relative motion or true motion.

1. Switching the motion mode

- (a) Press the [TM/RM] key. The screen display and function changes in the following sequence:

"RM" → "TM" → "CTM" → "RM"

RM: Relative motion. This mode displays other targets in relative motion fixing the own ship to the center.

Radar trails are displayed in relative motion.

TM: True motion. This mode displays the own ship and other targets in true motion on the screen with the earth being fixed.

Radar trails are displayed in true motion.

CTM: True motion with own ship fixed. This mode displays other targets in relative motion fixing the own ship to the center.

Radar trails are displayed in relative motion.

"True motion display TM"

The fixed position of own ship on the screen moves according to the ship speed and course. A fixed target like a land target is fixed onto the screen, and an actually moving target moves on the screen. The position of own ship is set to a position about 66% of the radius in the opposite direction of the course on the extension of the ship's heading marker (SHM) when the true motion display is enabled. The ship starts moving from the position according to the specified own ship's speed and course.

After that, when the own ship reaches a position 66% of the radius in the opposite direction, the own ship's position is automatically reset to the position at switching to the true motion display.

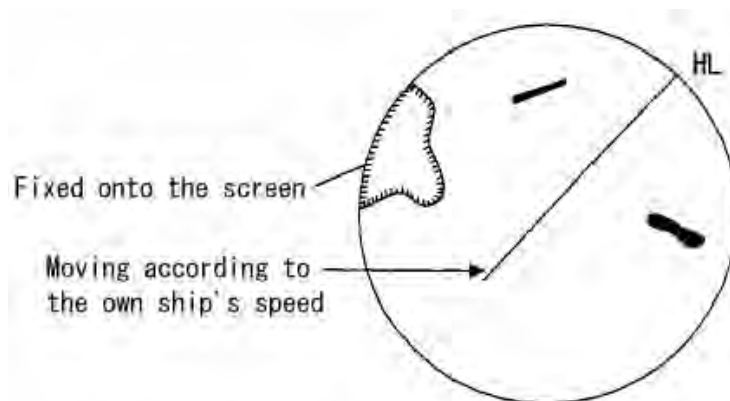

True motion display

2. Resetting own ship's position in true motion display (TM)

Reset method :

Hold down the [TM/RM] key.

The own ship's position is reset to the position at switching to true motion display, and the own ship starts moving from the position.

Allowable combinations of azimuth modes and motion modes

Available azimuth modes vary depending on the motion mode.

	H-UP	N-UP	C-UP
RM	○	○	○
TM	×	○	○
CTM	×	○	○

Difference between TM and CTM

The CTM mode always displays TM-mode images with the own ship as the center.

	TM	CTM
Own ship display	True motion	Fixed to the center
Another ship display	True motion display	Relative motion display
Image processing	True motion	True motion
Radar trails	True motion display	True motion display
Off-center	90%	90%

3.5.15 Suppressing the power consumption of the radar [MENU]

Use the intermittent transmitting function to suppress the power consumption.

The transmitting state and standby state are automatically switched while the intermittent transmitting function is used.

The intermittent transmitting function can freely set the periods of the transmitting state and standby state.

Period of the transmitting state → Set the number of times the antenna rotated.

Period of the standby state → Set the time while the standby state is placed.

1. Using the intermittent transmitting function [MENU]

Take the following steps to use the intermittent transmitting function:

- Press the **[MENU]** key to display **[MENU]**.
- Select **[TX PLAN]** and then **[TX PLAN]** pressing the **[JOG DIAL]** or **[ACQ/ENT]** key after each selection.
- The menu below is displayed. Turn **[JOG DIAL]** to select **[ON]**, and then press the **[JOG DIAL]** or **[ACQ/ENT]** key to determine the selection.

TX PLAN	
TX PLAN	OFF
OFF	10 SCAN
ON	3 MIN

When the intermittent transmitting function is turned ON, the transmitting state is placed only while the antenna rotates the preset number of times. Similarly, the standby state is placed only during the set time.

2. Canceling the intermittent transmitting function [MENU]

In step (c) above, select **[OFF]**, and then press the **[JOG DIAL]** or **[ACQ/ENT]** key to determine the selection.

3. Setting the period of the transmitting state (the number of antenna rotations) [MENU]

Take the following steps to set the number of antenna rotations:

- Press the **[MENU]** key to display **[MENU]**.
- Select **[TX PLAN]** and then **[TX PERIOD]** pressing the **[JOG DIAL]** or **[ACQ/ENT]** key after each selection.
- The menu below is displayed. Turn **[JOG DIAL]** to set the number of antenna rotations for placing the transmitting state, and then press the **[JOG DIAL]** or **[ACQ/ENT]** key to determine the setting.

TX PLAN	
TX PLAN	OFF
TX PERIOD	10 SCAN
1~99 SCAN	3 MIN

When the period of the transmitting state is set, the transmitting state is placed only while the antenna rotates the set number of times and then automatically switched to the standby state. After the standby state is placed for the set time, it is switched to the transmitting state again. Likewise, the two states are switched back and forth repeatedly.

4. Setting the period of the standby state [MENU]

Take the following steps to set the period of the standby state:

- (a) Press the **[MENU]** key to display **[MENU]**.
- (b) Select **[TX PLAN]** and then **[STBY PERIOD]** pressing the **[JOG DIAL]** or **[ACQ/ENT]** key after each selection.
- (c) The menu below is displayed. Turn **[JOG DIAL]** to set the time for placing the standby state, and then press the **[JOG DIAL]** or **[ACQ/ENT]** key to determine the setting.

TX PLAN	
TX PLAN	OFF
STBY PERIOD	10 SCAN
1~99 MIN	3 MIN

When the period of the standby state is set, the standby state is placed only for the set time and then automatically switched to the transmitting state. After the transmitting state is placed while the antenna rotates the set number times, it is switched to the standby state again. Likewise, the two states are switched back and forth repeatedly.

3.5.16 Monitoring the heading of other ships (targets) [ALARM ACK]

A guard zone can be set for warning the invasion of other ships or targets.

There are two guard zone modes - one mode issues an alarm when a ship or target gets into the specified guard zone, and the other mode issues an alarm when a ship or target gets out of the specified guard zone.

Caution

- The volume of the alarm is the same as the volume of the buzzer. Be careful that if the volume of the buzzer is set too low, you may not recognize that an alarm is issued.
- The alarm does not always respond to all targets. Thus, the alarm should be used simply as an auxiliary device, and the operator herself/himself should monitor the heading of other ships and targets with her/his eyes and ears.

1. Using the radar alarm [ALARM ACK]

Take the following steps to use the alarm function:

- Hold down the [ALARM ACK] key to display the [ALARM] menu.
- Select [ALARM] and then [ALARM ZONE] pressing the [JOG DIAL] or [ACQ/ENT] key after each selection.
- The menu below is displayed. Turn [JOG DIAL] to select [GUARD ZONE], and then press the [JOG DIAL] or [ACQ/ENT] key to determine the selection.

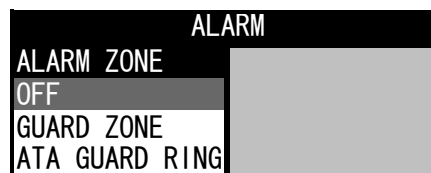

Note

Select [ATA GUARD RING] only when you use the optional MARPA function.

2. Canceling the radar alarm function

In step (c) above, select [OFF], and then press the [JOG DIAL] or [ACQ/ENT] key to determine the selection.

3. Creating a radar guard zone [ALARM ACK]

Take the following steps to create a radar guard zone for issuing a radar alarm:

- Hold down the [ALARM ACK] key to display the [ALARM] menu.
- Select [ALARM], [GUARD ZONE], and then [SETTING] pressing the [JOG DIAL] or [ACQ/ENT] key after each selection.
- A line is displayed for setting a guard zone. Operate [TRACK BALL] to set the range inside the guard zone, and then press the [JOG DIAL] or [ACQ/ENT] key.
- Operate [TRACK BALL] to set the range outside the guard zone and the starting angle of the guard zone, and then press the [JOG DIAL] or [ACQ/ENT] key.

- (e) Operate **[TRACK BALL]** to set the ending angle of the guard zone, and then press the **[JOG DIAL]** or **[ACQ/ENT]** key to determine the setting.

GUARD ZONE	
ALARM MODE	IN
ALARM LEVEL	8
SETTING	

Caution

● Radar guard zone modes

There are two guard zone modes (invade and leave) - the invade mode issues an alarm when a ship or target gets into the specified guard zone, and the leave mode issues an alarm when a ship or target gets out of the specified guard zone. Note that the range specified as the radar guard zone is displayed only when the radar is in transmitting state. It is not displayed when the radar is in standby state.

4. Setting a radar guard zone **[ALARM ACK]**

Take the following steps to set the mode that issues an alarm when a target gets into the specified radar guard zone or when a target gets out of the specified radar guard zone:

- Hold down the **[ALARM ACK]** key to display the **[ALARM]** menu.
- Select **[ALARM]**, **[GUARD ZONE]**, and then **[ALARM MODE]** pressing the **[JOG DIAL]** or **[ACQ/ENT]** key after each selection.
- The menu below is displayed. Turn **[JOG DIAL]** to select **[IN]** or **[OUT]**, and then press the **[JOG DIAL]** or **[ACQ/ENT]** key to determine the selection.

GUARD ZONE	
ALARM MODE	IN
IN	8
OUT	

5. Setting a radar guard zone detection level **[ALARM ACK]**

Take the following steps to set the detection level of a guard zone:

- Hold down the **[ALARM ACK]** key to display the **[ALARM]** menu.
- Select **[ALARM]**, **[GUARD ZONE]**, and then **[ALARM LEVEL]** pressing the **[JOG DIAL]** or **[ACQ/ENT]** key after each selection.
- The menu below is displayed. Turn **[JOG DIAL]** to set an alarm level 0 to 15, and then press the **[JOG DIAL]** or **[ACQ/ENT]** key to determine the setting.

GUARD ZONE	
ALARM MODE	IN
ALARM LEVEL	8
8	

Caution

- An alarm level 0 to 8 can be set as the volume of the alarm. As a lower value is specified, the alarm responds to a weaker target.
Be careful that if a set alarm level is too high, the alarm may not work when it should.

3.5.17 Resetting an alarm (stopping a warning) [ALARM ACK]

This section explains how to stop the alarm when an alarm is issued as a warning.

Stopping the alarm

Press [ALARM ACK] key.

The alarm stops.

3.5.18 Displaying parallel line cursors [MENU], [VRM], [EBL]

Parallel line cursors are displayed across the whole PPI display.

When parallel line cursors are displayed, VRM2 and EBL2 are used to set the turning angle and the spacing of parallel line cursors.

Displaying parallel line cursors

Take the following steps to display parallel line cursors:

- Press the [MENU] key to display [MENU].
- Select [DISP OPTIONS] and then [PARALLEL LINE] pressing the [JOG DIAL] or [ACQ/ENT] key after each selection.
- The menu below is displayed. Turn [JOG DIAL] to select [ON], and then press the [JOG DIAL] or [ACQ/ENT] key to determine the selection.

DISP OPTIONS	
EBL BEARING	TRUE
FROATING EBL	OFF
PARALLEL LINE	OFF
OFF	NM
ON	NM
WAYPOINT	OFF
POSITION	LL
LL-TD CONV>	

The parallel line cursors turn in the direction in which EBL2 turns.

The spacing of parallel line cursors can be changed in the direction in which VRM2 turns.

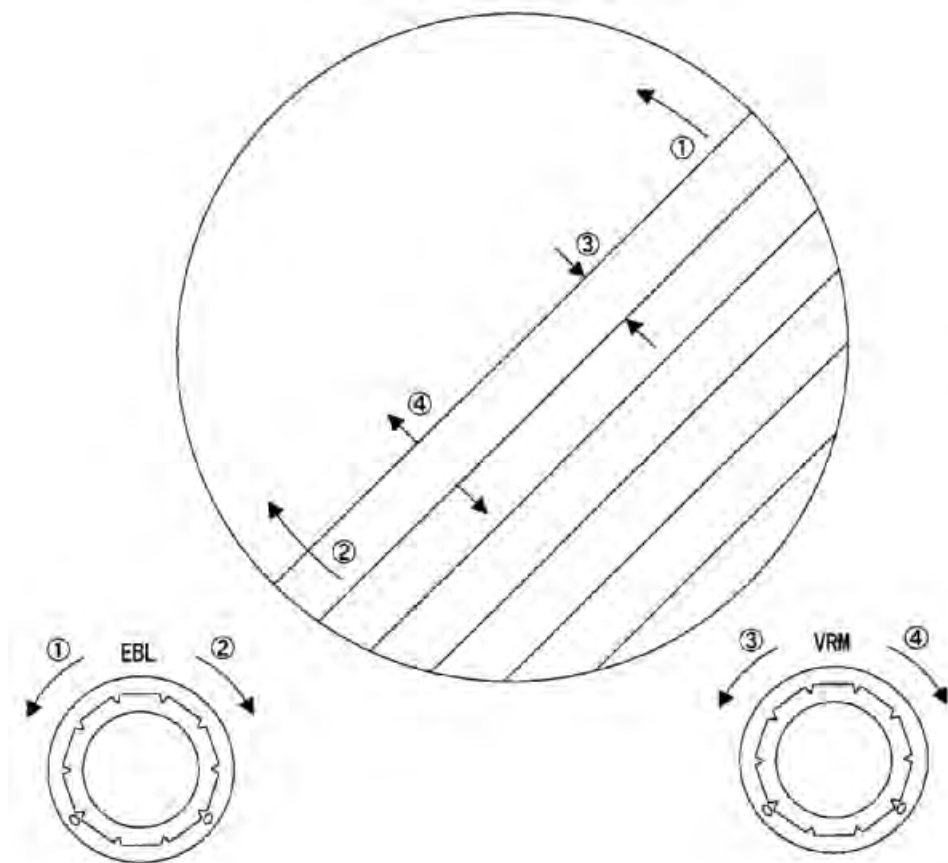

Parallel line cursor display

<Changing the spacing of parallel line cursors>

The bearing and the spacing of parallel line cursors can be changed in EBL2 mode and VRM2 mode, respectively.

3.5.19 Using the MOB function [MOB]

MOB is also called a falling-into-sea mark. If a person or object falls into the sea, press the **[MOB]** key. The latitude and longitude of the position are stored and the MOB mark is displayed. A straight line from the own ship to the mark is also displayed.

The numeric value display area displays the distance from the own ship to the MOB mark, the bearing, and the latitude and longitude of the MOB mark.

1. Displaying the MOB mark

- (a) Press the **[MOB]** key.
- (b) The MOB mark is displayed at the own ship's position. The distance to the MOB mark, the bearing, and the latitude and longitude of MOB mark position are displayed in the numeric value display area.

2. Erasing the MOB mark

- (a) Hold down the **[MOB]** key.
The MOB mark and numeric value display are erased.

Caution

- The MOB mark is displayed only on condition that a navigator is connected and latitude/longitude information is input.
The MOB function does not work unless latitude/longitude information is input.

3.5.20 Using the WAYPOINT function [MENU]

When the radar receives BWC or RMB from the navigator, it displays the distance to the destination, the bearing, and the latitude and longitude of the destination in the numeric value display area.

1. Displaying WAYPOINT

Take the following steps to display waypoint:

- Press the **[MENU]** key to display **[MENU]**.
- Select **[DISP OPTIONS]** and then **[WAYPOINT]** pressing the **[JOG DIAL]** or **[ACQ/ENT]** key after each selection.
- The menu below is displayed. Turn **[JOG DIAL]** to select **[ON]**, and then press the **[JOG DIAL]** or **[ACQ/ENT]** key to determine the selection.

DISP OPTIONS	
EBL BEARING	TRUE
FROATING EBL	OFF
PARALLEL LINE	OFF
VRM1 UNITS	NM
VRM2 UNITS	NM
WAYPOINT	OFF
OFF	LL
ON	

2. Erasing WAYPOINT

In step (c) above, select **[OFF]**, and then press the **[JOG DIAL]** or **[ACQ/ENT]** key to determine the selection.

- When WAYPOINT and MOB are operating simultaneously, it can change by holding down the **[TGT DATA]** key.

3.5.21 Own ship display function [MENU]

When you display the own ship's position through the navigator, use this function to determine whether to select the latitude/longitude display or the conventional time difference display LORAN-C.

Switching own ship display

Take the following steps to switch own ship's position information to the latitude/longitude display or the time difference display:

- Press the **[MENU]** key to display **[MENU]**.
- Select **[DISP OPTIONS]** and then **[POSITION]** pressing the **[JOG DIAL]** or **[ACQ/ENT]** key after each selection.
- The menu below is displayed. Turn **[JOG DIAL]** to select **[LL]** for the latitude/longitude display or **[TD]** for the time difference display of LORAN-C, and then press the **[JOG DIAL]** or **[ACQ/ENT]** key to determine the selection.

DISP OPTIONS	
EBL BEARING	TRUE
FROATING EBL	OFF
PARALLEL LINE	OFF
VRM1 UNITS	NM
VRM2 UNITS	NM
POSITION	OFF
LL	LL
TD	

3.5.22 Function to convert time difference display to latitude/longitude display [MENU]

This function sets a value necessary when the own ship's position display is converted from the conventional time difference display of LORAN-C to the latitude/longitude display.

Setting LORAN-C values

Take the following steps to set LORAN-C information for switching to the latitude/longitude display:

1. Setting the LORAN chain (base station number)

- Press the **[MENU]** key to display **[MENU]**.
- Select **[DISP OPTIONS]** and then **[LL-TD CONV]** pressing the **[JOG DIAL]** or **[ACQ/ENT]** key after each selection.
- Turn **[JOG DIAL]** to select **[LORAN-C GRI]**.
- The menu below is displayed. Turn **[JOG DIAL]** to select the chain you want, and then press the **[JOG DIAL]** or **[ACQ/ENT]** key to determine the selection.

LL-TD CONV	
LORAN-C GRI	4900
4900	0
LORAN-C TD2	0
TD COR. TD1	0.0
TD COR. TD2	0.0

2. Setting time difference (TD1 or TD2)

- Press the **[MENU]** key to display **MENU**.
- Select **DISP OPTIONS** and then **LL-TD CONV** pressing the **[JOG DIAL]** or **[ACQ/ENT]** key after each selection.
- Turn **[JOG DIAL]** to select **LORAN-C TD1** or **LORAN-C TD2**.
- Turn **[JOG DIAL]** to set the value of TD1 or TD2, and then press the **[JOG DIAL]** or **[ACQ/ENT]** key to determine the setting.

LL-TD CONV	
LORAN-C GRI	4900
LORAN-C TD1	0
0	0
TD COR. TD1	0.0
TD COR. TD2	0.0

Setting TD1 (Select the item one case lower for TD2.)

3. Setting the correction value (of TD1 or TD2)

- Press the **[MENU]** key to display **MENU**.
- Select **DISP OPTIONS** and then **LL-TD CONV** pressing the **[JOG DIAL]** or **[ACQ/ENT]** key after each selection.
- Turn **[JOG DIAL]** to select **TD COR. TD1** or **TD COR. TD2**.
- Turn **[JOG DIAL]** to set the correction value of TD1 or TD2, and then press the **[JOG DIAL]** or **[ACQ/ENT]** key to determine the setting.

LL-TD CONV	
LORAN-C GRI	4900
LORAN-C TD1	0
LORAN-C TD2	0
TD COR. TD1	0.0
0.0	0.0

Setting the correction value of TD1 (Select the item one case lower for TD2.)

3.5.23 Cursor/own-ship position output function [CSR POS]

This function outputs the information of the bearing and distance from the current own ship's position to cursor position.

The above information is output from the processing unit J8.

Outputting the bearing and distance from the current own ship's position to cursor position.

- Press the **[CSR POS]** key.
- The J8 outputs the cursor position data. (RSD)

Outputting the bearing and distance when the cursor is the own ship's position.

(Outputs "bearing = 0", "distance = 0")

- Hold down the **[CSR POS]** key.
- The J8 outputs the cursor position data. (RSD)

Caution

- The initial setting item determines whether to output the above data. For details, see the initial setting item 9.8.29, "Setting a NMEA data output frequency [MENU]."

3.6 Use of Function Keys

3.6.1 Overview

The purpose of function keys is to always get the best radar images by :

- Storing and using complex radar signal processing settings in the optimum status by usage, and
- Calling optimum signal processing settings for the sea conditions, weather, ship dimensions, and the like.

Four function key modes are available.

The four modes mean that four different signal processing and radar settings can be stored separately.

In other words, as long as signal processing setting suitable for short-range observation, optimum signal processing for trawling, and trail setting have been registered, each setting can be selected instantaneously by simply pressing the **[FUNC]** key to switch to the mode.

As explained in the above, you can register any setting for functions 1 to 4. The following are 13 typical signal settings that can be selected:

OFF :	Off
STAND :	Setting for standard situation
COAST :	Setting for coast navigation
DEEPSEA :	Setting for deep-sea navigation
FISHNET :	Setting for fish net detection
STORM :	Setting for storm weather
CALM :	Setting for calm weather
RAIN :	Setting for rain/snow
BIRD :	Setting for bird detection
LONG :	Setting for long-range detection
BUOY :	Setting for buoy detection
USER1 :	User setting 1 (Used for setting not included in the 11 settings above)
USER2 :	User setting 2 (Used for setting not included in the 11 settings above)

The signal processing settings above are defined in accordance with the titles. Users can make further detailed settings meeting their needs.

Functions 1 to 4 are factory-set to the titles and signal processing settings as follows:

FUNC1 :	COAST
FUNC2 :	DEEPSEA
FUNC3 :	FISHNET
FUNC4 :	RAIN

3.6.2 Operation procedures

1. Calling a function

Each time the **[FUNC]** key is pressed, the cursor moves in the following sequence:
STANDARD → FUNC1 → FUNC2 → FUNC3 → FUNC4 → STANDARD

The title of the currently called mode is displayed at the upper right of the screen.

Suppose that signal processing settings are defined for FUNC1 with COAST as the title, FUNC2 with DEEPSEA as the title, FUNC3 with FISHNET as the title, and FUNC4 with RAIN as the title. Each time the **[FUNC]** key is pressed, the function titles are displayed at the upper right of the screen in the order of COAST, DEEPSEA, FISHNET, and then RAIN. You can confirm the currently selected function mode glancing at the screen.

2. Changing the setting of a function key

You can change the settings of a function key just as when performing general operation.

After the title displayed at the upper right of the screen is switched by pressing the **[FUNC]** key, settings made in that status are stored as they are.

For example, if FUNC1 (COAST) is selected by pressing the **[FUNC]** key, the title COAST is displayed at the upper right of the screen. This explains that the coast navigation function mode is now active. Settings (e.g., signal processing settings and radar setting) made in the mode are stored for FUNC1 (coast navigation mode).

3. Changing a function key title

The title displayed at the upper right of the screen can be easily changed.

Perform the procedure below to change any of the factory-set titles previously mentioned.

Take the following steps to change a function key title:

- Hold down the **[FUNC]** key to display the **FUNCTION** menu.
- The menu below is displayed. Select the function key **FUNC1** to **FUNC4** of which title you want to change, and then press the **[JOG DIAL]** or **[ACQ/ENT]** key.

FUNCTION	
STANDARD	>
FUNC1	>
FUNC2	>
FUNC3	>
FUNC4	>

- The menu below is displayed. Select **MODE**, and then press the **[JOG DIAL]** or **[ACQ/ENT]** key.

STANDARD	
MODE	> COAST
VIDEO	>
TRAILS	>
PULSE LENGTH	>
INITIALIZE	>

- (d) The menu below is displayed. Select the signal processing you want to set by turning **[JOG DIAL]**, and then press the **[JOG DIAL]** or **[ACQ/ENT]** key to determine the setting.

You can select the settings of signal processing as shown below.

- OFF : Off
- STAND : Use for standard situation
- COAST : Use for coast navigation
- DEEPSEA : Use for deep-sea navigation.
- FISHNET : Use for detecting fish nets.
- STORM : Use for storm weather.
- CALM : Use for calm weather.
- RAIN : Use for strong rain/snow.
- BIRD : Use for detecting birds flying on the sea.
- LONG : Use for detecting weak targets in longrange.
- BOUY : Use for detecting the radio bouy.
- USER1 : Set it as free uses other than the above.
- USER2 : Set it as free uses other than the above.

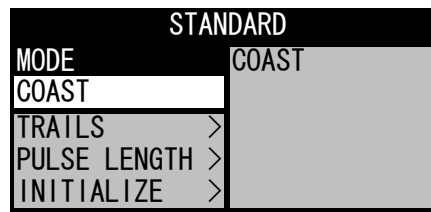

4. Initializing the setting of a function key (Returning to the factory setting)

If you are confused making various settings or want to make a new setting, you can return the current setting to the factory setting for each function mode.

Take the following steps to initialize the setting of a function key:

- (a) Take steps (a) and (b) in 3 above, select **INITIALIZE**, and then press the **[JOG DIAL]** or **[ACQ/ENT]** key.
- (b) The menu below is displayed. Select **YES**, and then press the **[JOG DIAL]** or **[ACQ/ENT]** key to determine the selection.

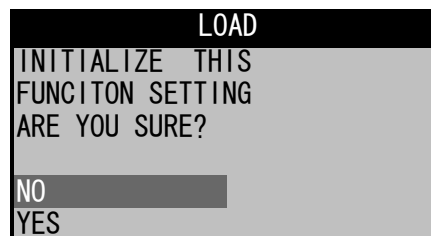

Only the above items can be set in the **FUNCTION** menu. All the other menus are only for confirming the settings. The following shows **FUNCTION** menu lists:

Function key menu lists (display only)

Level 1 menu

FUNCTION	
STANDARD	>
FUNC1	>
FUNC2	>
FUNC3	>
FUNC4	>

Level 2 menu

STANDARD	
MODE	COAST
VIDEO	>
TRAILS	>
PULSE LENGTH	>
INITIALIZE	>

Level 3 menu

VIDEO	
INTERFERENCE	OFF
TGT EXPANSION	OFF
PROCESS	OFF
PROC SW RANGE	3.0NM
AUTO STC/FTC	
VIDEO LATITUDE	OFF
VD NOISE REJ	NORMAL
GAIN OFFSET	0
XMIT REP. FREQ	NORMAL
S-BUOY DETECT	OFF
NEXT	

VIDEO	
BACK	
F-NET DETECT	OFF
IR SHIFT	OFF
DR RANGE CONT	OFF
TGT EXP LEVEL	LEVEL1
TGT EXP PROC	OFF

TRAILS	
TRAIL INTERVAL	6M
TRAIL REF LVL	8
TRAIL SUPPRESS	OFF

PULSE LENGTH	
1.5NM	0.08us
3NM	0.25us
6NM	0.5us

STANDARD	
MODE	STANDARD
VIDEO	>
TRAILS	>
PULSE LENGTH	>
INITIALIZE	>

STANDARD	
MODE	STANDARD
VIDEO	>
TRAILS	>
PULSE LENGTH	>
INITIALIZE	>

All the level 3 menus at left are only for display.

The settings of menu items can be changed and displayed by changing the settings of the items in other menus.

3.7 Other Procedures Required

3.7.1 Confirming software versions [MENU]

The versions of software installed in the processor, antenna, and operation unit can be displayed. If a failure occurs, inform our engineer of the software versions as well as details on the failure.

Take the following steps to confirm the software versions:

- (a) Press the [MENU] key to display .
- (b) Select and then pressing the [JOG DIAL] or [ACQ/ENT] key after each selection.

The software versions are displayed as shown below.

SOFTWARE VER.	
MAIN	V 1.00 2003/01/01
PANEL	V 1.00
PANEL2	V 1.00
SCANNER	V 1.00
ATA	V 1.00
NSK	-----

3.7.2 Confirming the operating status of connected units [MENU]

The status of the units (e.g., the processor, antenna, and operation unit) currently connected to this radar can be displayed.

If a failure occurs, inform our engineer of the unit connection status as well as details on the failure.

Take the following steps to confirm the unit connection status:

- (a) Press the [MENU] key to display .
- (b) Select and then pressing the [JOG DIAL] or [ACQ/ENT] key after each selection.

The unit connection status is displayed as shown below.

PORT CONNECT	
GPS	NMEA0183
COMPASS	JLR-10
PC	NMEA0183
SCANNER	CONNECT
PANEL	CONNECT
PANEL2	NONE
ATA	NONE

3.7.3 Displaying magnetron current [MENU] [+RANGE-]

The current value of magnetron is displayed. The status of magnetron can be interpreted by the value.

Take the following steps to display magnetron current.

- (a) Operate the [+RANGE-] key to set 48 mile.
When the range is already set to "48NM", this operation is not necessary.
- (b) Hold down the [MENU] key to display the [INSTALLATION] menu, select [RADAR], [RADAR ADJUST], and [MAG.I], and press the [JOG DIAL] or [ACQ/ENT] key.
- (c) A value and bar "■■■■" is displayed, you can interpret the magnetron status by the value.

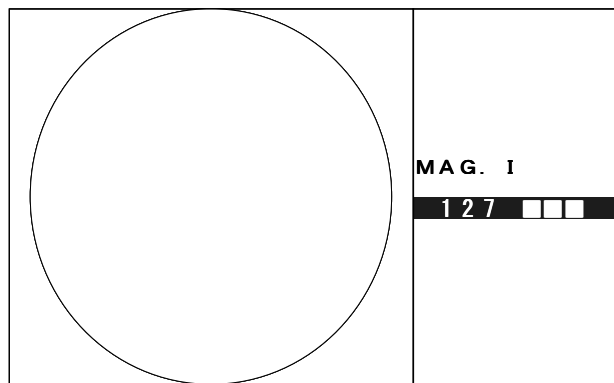

The bar shakes according to the following value.

From 12 to 24	■■
From 25 to 37	■■■
From 38 to 50	■■■■
From 51 to 63	■■■■■
From 64 to 76	■■■■■■
From 77 to 89	■■■■■■■
From 90 to 102	■■■■■■■■
From 130 to 115	■■■■■■■■■
From 116 to 127	■■■■■■■■■■

In the case of 4kw : From 60 to 80 ■■■■■■■■~■■■■■■■■■■ (Approximately)

In the case of 6kw : From 70 to 90 ■■■■■■■■~■■■■■■■■■■ (Approximately)

In the case of 10kw : From 70 to 90 ■■■■■■■■~■■■■■■■■■■ (Approximately)

The shaking bar may be shifted, even if it is a new magnetron.
Certainly use this display as a reference.

3.7.4 Confirming error logs [ALARM ACK]

If any of the sensors malfunctions, the error log function lists faulty locations.

If a failure occurs, inform our engineer of the error log contents as well as details on the failure.

Take the following steps to confirm error logs:

- (a) Hold down the [ALARM ACK] key to display the [ALARM] menu.
 - (b) Select [ERROR LOG], and then press the [JOG DIAL] or [ACQ/ENT] key.
- Error logs are displayed as shown below.

ERROR LOG	
BACK	
CPA/TCPA	1
GZ	3
LOST	2
PRC-TRIGGER	1
NEXT	

Error list

When a error occurs, the following error is displayed at the lower right of the screen, and is saved in the error log.

When you connect to our company or an agency, tell contents of the error log at the time of failure.

TRX	No communication error with transmitter or receiver
TRX-DATA	Data error with transmitter or receiver
PANEL	No communication error with control unit
PANEL DATA	Data error with control unit
PANEL2	No communication error with subcontrol unit
PANEL2 DAT	Data error with subcontrol unit
GPS	No communication error with GPS equipment
GPS DATA	Data error with GPS equipment
GPS STATUS	Status error with GPS equipment
COMPASS	No communication error with magnetic compass equipment
COMP DATA	Data error with magnetic compass equipment
PC	No communication error with personal computer
PC DATA	Data error with personal computer
NSK	No communication error with NSK unit
NSK DATA	Data error with NSK unit
GYRO	Status error with NSK unit
LOG	Status error with NSK unit
GPS COMP	No communication error with GPS compass
GCOMP DATA	Data error with GPS compass
TRX-HEATER	Heater error of transmitter or receiver

TRX-MHV	Moduration error of transmitter or reciever
SSW OFF	Safety switch OFF of scanner unit
TRX-HL	Standard rotation signal error of scanner unit
TRX-AZI	Rotation signal error of scanner unit
TRX-REV	Reverse rotation error of scanner unit
TRX-TRIGGER	Transmission trigger error of scanner unit
TRX-VIDEO	Video error of scanner unit
PRC-HL	Standard rotation signal error of display unit
PRC-AZI	Rotation signal error of display unit
PRC-TRIGGER	Trigger signal error of display unit
PRC-VIDEO	Video signal error of display unit

3.7.5 Clearing the error log [ALARM ACK]

Take the following steps to clear the error log.

- Hold down **[ALARM ACK]** key to display the **[ALARM]** menu.
- Select **[ERROR LOG CLR]**, and then press **[JOG DIAL]** or **[ACQ/ENT]**.
- The menu below is displayed. Turn **[JOG DIAL]** to select **[ON]**, and then press the **[JOG DIAL]** or **[ACQ/ENT]** key to determine the selection.

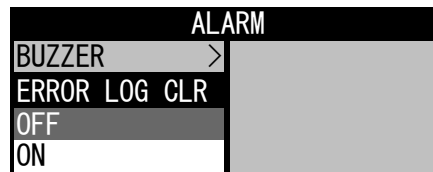

3.7.6 Operating the self-diagnostic function [MENU]

The self-diagnostic function is installed to activate the self-diagnostic mode after the power is turned on.

This function gets the system to automatically diagnose itself for normal operation.

Take the following step to start the self-diagnostic function:

- Turn on the power while pressing the **[EBL]** and **[VRM]** keys at the same time.
The self-diagnostic function starts.

3.7.7 Displaying the help menu

The HELP function is installed to explain keys for operating special functions when the power is turned on.

Take the following steps to operate the HELP function:

- Hold down the **[MENU]** key to display **[MENU]**.
- Operate **[JOG DIAL]** to select **[HELP]**, and then press the **[JOG DIAL]** or **[ACQ/ENT]** key.

As shown below, the keys for operating special functions are displayed in two lists when the power is turned.

HELP	
INITIALIZE ALL	ACQENT+MENU
SELF TEST	EBL+VRM
LANGUAGE	ALM ACK
DISP MOUNT UP	TUNE
DISP MOUNT R	RAIN
DISP MOUNT REV	SEA
DISP MOUNT L	GAIN

3.7.8 Replacing the battery (BT1)

The battery (BT1) needs to be replaced regularly to hold the set information.

(a) Replacing the battery (BT1)

The battery is provided in the main control circuit (CMC-1190).

The battery model is CR2477-1VC.

Ask the nearest sales agent to replace the battery.

(b) Initial settings after battery replacement

- Even if the power is turned off, the settings of menus and software keys are held through this lithium battery. Consequently, when the power is turned on next, the radar is operable in the status in which it was most recently used.

- When the battery reaches the end of its useful life, all the settings including menus are automatically reset.

Therefore, the initial settings need to be made again after battery replacement.

Caution

- **When the battery nears the end of its useful life, the range and bearing may not be measured correctly.
Replace the battery immediately, and make the initial settings.**

(c) If the battery cannot be replaced immediately, as first-aid measures, make the initial settings each time you turn on the power. In this case, note that all the settings are reset when the power is turned off.

- **For the initial settings, see 9.7, "Initialization."**

3.7.9 Procedure if an incomprehensible symptom occurs during use of the radar

If a symptom such as the distortion of screen display or the refusal of switch operation takes place during use of the radar, perform the initialization procedure below.

Caution

- When INITIALIZE is executed, ENGINEERS MENU is initialized. However, the contents stored by **BACKUP MEMORY** are not initialized.
- When the battery for backup wears down, the contents stored by **BACKUP MEMORY** are initialized.

- (a) Turn on the power while pressing the **[MENU]** key and **[ACQ/ENT]** key at the same time.
- (b) The **[NO]** and **[YES]** menu is displayed after the menu below. Turn **[JOG DIAL]** to select **[YES]**, and then press the **[JOG DIAL]** or **[ACQ/ENT]** key to determine the selection.

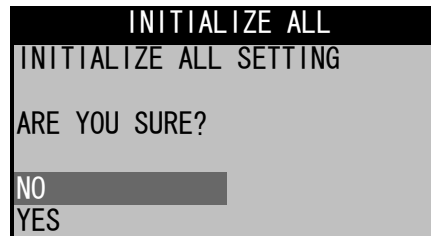

Chapter 4 How to Interpret the PPI Screen

4.1 Height of and the Distance to the Target

The maximum distance to a target that can be observed with a radar depends not only on the power of the radar's transmitter, beam width of the scanner unit, and the receiver's sensitivity but also on height of a target, distance to a target and height of scanner unit line etc. This is because the radio wave emitted by a radar runs straight, undergoing no influence by the curvature of the earth surface.

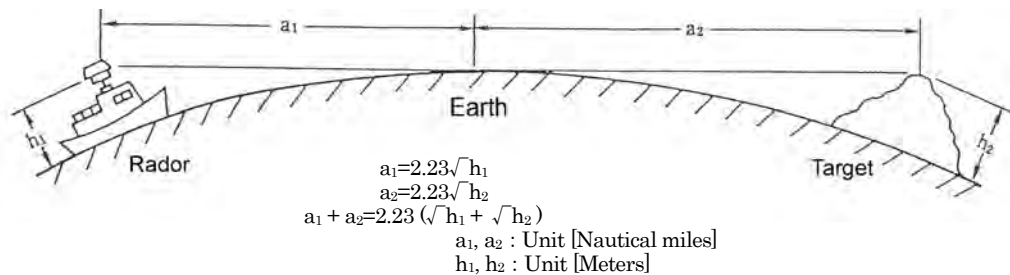

[Distance and Target]

For example, when the scanner unit lies 3 meters above the sea level, the radar can detect and display an island with a height of 10 meters at a distance 10 NM away from the scanner unit position but cannot detect and display an island with a height of 5 meters at the same distance. This is theoretically true but does not always hold, depending on weather conditions.

For a target located 10 NM away to be displayed on a radar, it theoretically needs to be 7.6 meters or higher. Any targets lower than 7.6 meters cannot be displayed on a radar.

● The target may be unable to be observed when the height of a scanner unit or an target is low.

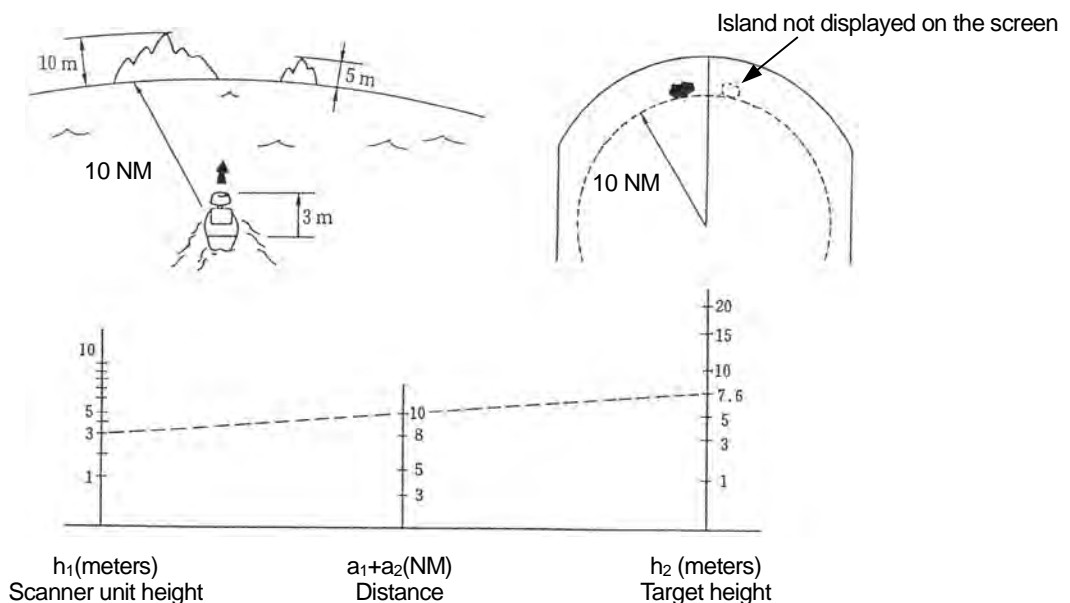

4.2 Returns from a Target

The intensity of returns from a target is related not only to the size of the target but also to the materials and shape of the components making up the target. Accordingly, larger objects do not necessarily develop strong returns.

On coastlines, in particular, the intensity of returns is dependent on their physiographic features. For a coastline with a fairly gradual ascent, only inland mountain areas may be displayed as echoes. This fact needs to be kept in mind when measuring the distance to a coastline.

- Since the echo which returns from a coastline with a fairly gradual ascent is weak, observation of such land may not be able to be performed.

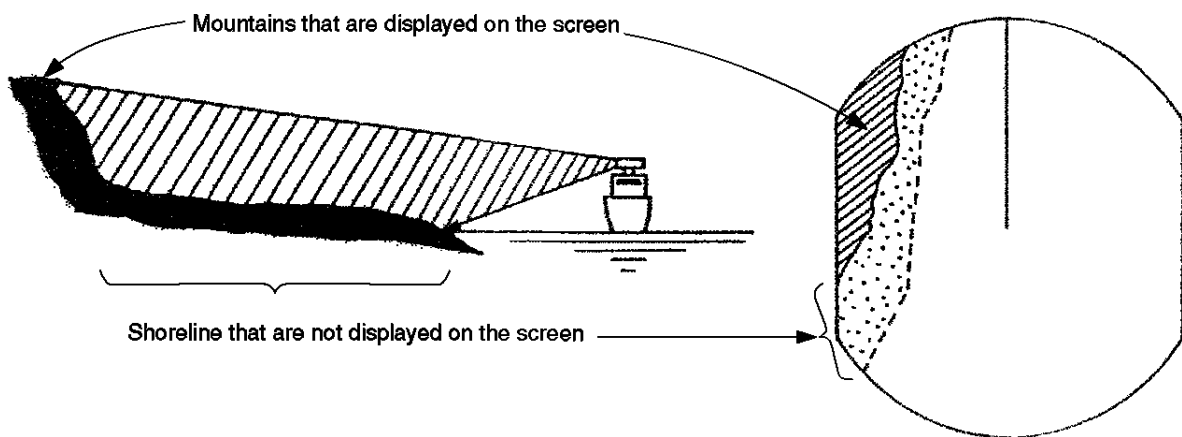

4.3 Propagation Path of Radio Waves

- Radio waves may be shielded if there is a large intercepting obstacle (e.g., mountains, rain, snow, etc.) in their propagation path and any targets behind the obstacle cannot be observed.

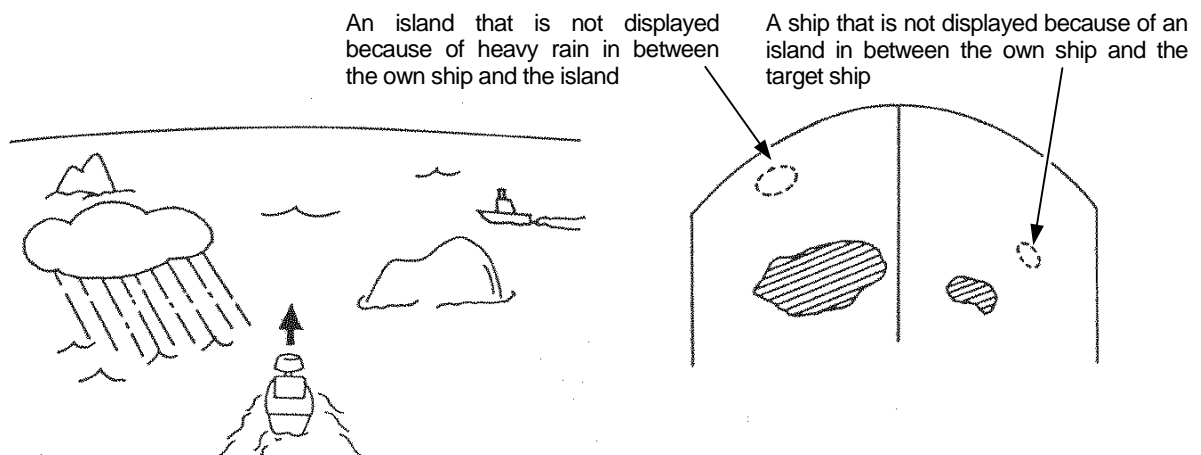

4.3.1 Sea returns

On a wavy sea surface, an echo appears on the PPI screen as a bright defused image at the center of the screen. This echo is developed by returns from the sea surface. The features of the echo depend on the size and range of the wave, and the wind direction.

4.3.2 False echoes

There are cases in which nonexistent targets appear as echoes or in which existing targets do not appear as echoes on the PPI screen. These echoes are called false echoes.

False echoes are produced by the factors explained below.

● Please observe carefully in consideration of there being always false echoes.

(a) Ghost

Depending on the location where the scanner unit is installed, radio waves are emitted from nearby chimney stacks or masts, developing ghosts. Consequently, targets that are located in those direction may not appear as echoes on the PPI screen.

The presence of these ghosts can be identified by observing sea returns and checking the returns for dim areas or voids.

If a ghost is detected, remember the direction in which it appears and observe the target carefully.

(b) Side echo

There are cases in which an arc-shaped broken line appears over the same range as the echo from the target. This image is caused by the side lobes of the beam emitted from the scanner unit. This type of false echoes can easily be identified if the target stands alone.

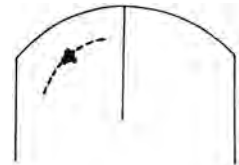

(c) Indirect echo

The direction of the radio wave from the radar may be changed by a reflection (secondary reflection) at a chimney stack or mast of a ship, developing a false echo in a direction in which there should be no target.

The indirect echo developed by the secondary reflection appears in the direction of the chimney stack or mast that reflected the radio wave.

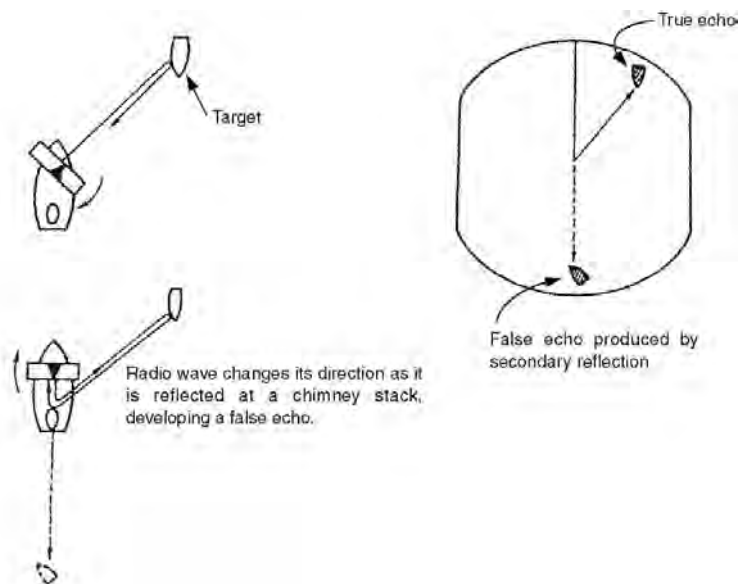

(d) Multiple echo

Multiple echoes are developed by multiple reflections caused by a building or large vessels that has large vertical surfaces. These echoes are spaced at an equal interval, with the one that is closest to the own ship being the true echo.

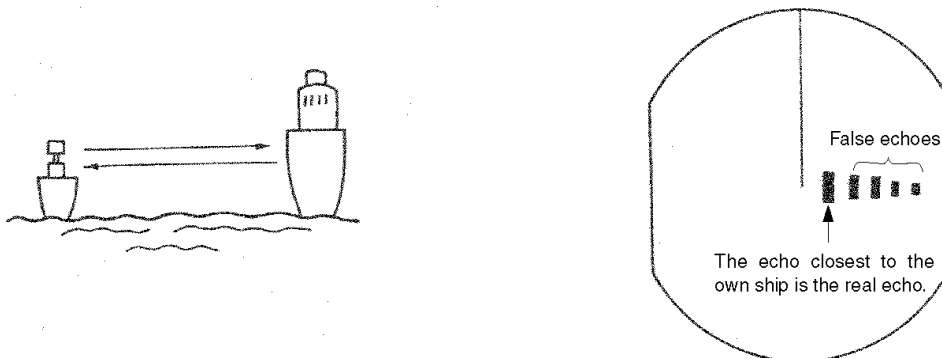

(e) Radar interference

If there is a radar that uses the same frequency as that of the own ship near the own ship, interferences caused by that radar appear on the PPI screen. These interferences appear as clusters of spots of varying patterns. Since they do not occur at the same location with time, they can easily be distinguished from true echoes.

Radar interferences can be reduced or eliminated by choosing "ON" from "FUNCTION"-"IR".

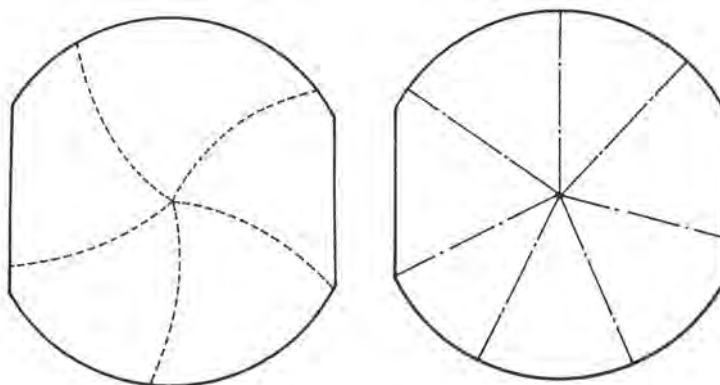

[Examples of radar interferences]

4.4 Display of Radar Transponder

SART (Search and Rescue Radar Transponder) is life preserving device approved by GMDSS which is used for locating survivors in the event of a disaster or distress. SART operates in the 9GHz frequency band. When it receives a radar signal (interrogating radio wave) of 9GHz transmitted by a rescue ship or aircraft radar, SART transmits a series of response signals to the searchers to indicate the distress position.

In order to see the SART or radar beacon mark on the radar screen.

- ① RANGE SCALE : Select 6 or 12 nm
- ② SEA CLUTTER control : Set to minimum
- ③ AUTO SEA : OFF
- ④ TUNE control : DETUNED to reduce the clutter
- ⑤ IR : Set IR OFF
- ⑥ PROCESS : Set PROCESS OFF

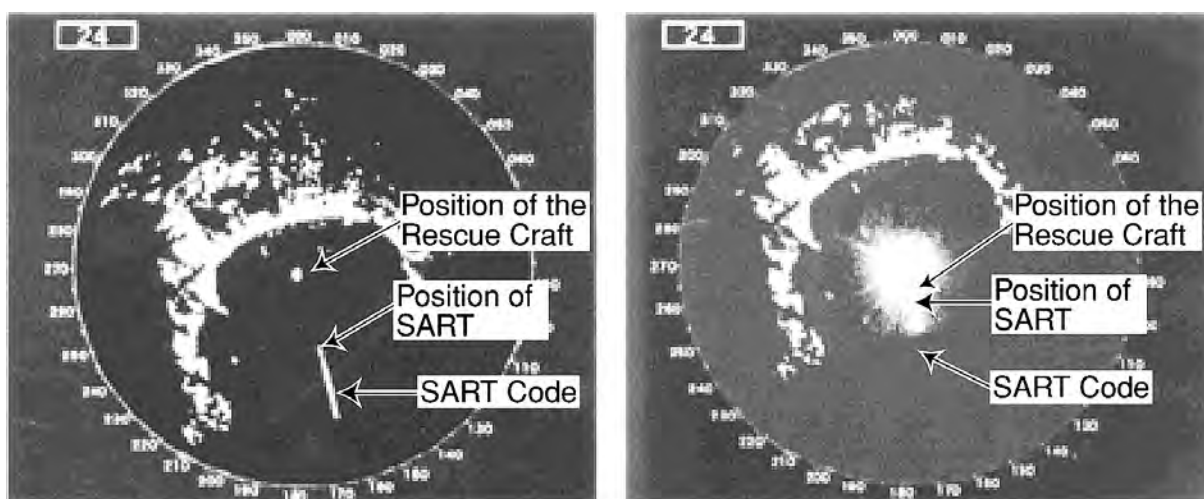

[Example]

Caution

- When above settings ① to ⑥ are made to display SART signals, objects around the own ship will not appear on the radar screen, so perform thorough visual monitoring of the sea area around the own ship to avoid any collision or stranding.

Further, when more than one radar systems are mounted, while using a 9GHz band radar for searching SART signals, be sure to use another radar as an ordinary radar to perform monitoring of objects around the own ship to avoid any collision, check of the position of the own ship to avoid any stranding, and so on.

Need to return the set for normal operation on completion.

Chapter 5 Maintenance and Inspection

5.1 General Maintenance

DANGER



The customer should refrain from inspecting or repairing the internal parts of this equipment.

Inspection or repair other than by specialized service personnel may cause death or a serious injury of any person.

Please contact the sales department of Japan Radio Co., Ltd. or your local branch, outlet or sales office with respect to maintenance and repair.



When performing maintenance in increment weather, please be sure to shut the main power off.

Maintenance work performed without shutting the main power off may cause death or a serious injury of any person by electric shock.

Caution

- **When cleaning the surface, please refrain from using organic solvents such as thinner or benzene.**

Use of such organic solvents may damage the surface coating.

When cleaning the surface, remove dust and grime and wipe with a clean dry cloth.

The following maintenance steps are required to ensure that the radar always operates in the optimal condition. Since breakdowns will be reduced through maintenance, periodic maintenance is recommended.

General maintenance steps common to all equipment are as follows.

Cleaning

Remove dust, grime and sea water that has adhered to the unit. Use dry cloth to clean the unit. In particular, use a brush to clean the ventilating opening to ensure smooth flow of air.

5.2 Scanner Unit

DANGER



When performing maintenance or inspection of the scanner unit, be sure to shut off the main power source.
Sudden movement of the scanner may cause death or a serious injury of any person.



Be sure to shut off the main power source when approaching the scanner unit for the purposes of maintenance or inspection.
Exposure to electric waves at proximate distances may cause death or a serious injury of any person.

(1) Radiation unit

If the front of the radiation unit is soiled with soot, salt, paint specks, bird excrement or other alien matter, electric waves may become attenuated and reflection may occur thus causing degradation in the performance of the radar.

The radiation unit should be inspected and always kept clean by wiping with cloth soaked in alcohol or water in the event of soiling.

Solvents such as gasoline, benzene, trichlene or ketone should never be used for this purpose.

(2) Pedestal

The pedestal and attachment bolts of the scanner unit should be inspected periodically for erosion and maintained to ensure safety. Painting is the best measure for preventing erosion and it is recommended that this be undertaken once in half a year.

5.3 Display Unit

Cleaning the LCD

When dust adheres to the LCD, transparency degrades and the images become dark.

Cleaning is performed using cloth soaked in water (flannel or cotton). Wiping vigorously with dry cloth or the use of gasoline or thinner should be avoided.

Caution

- **Vigorous wiping with dry cloth or the use of gasoline or thinner should be avoided in cleaning the LCD.**
Such action may cause scratches and deterioration.

5.4 Special Parts

JMA-5104

Model Number	Name	Type	Manufacturer	Location of use	JRC Code
V201	Magnetron	MSF1421B	New JRC	Scanner unit	5VMAA00049
A101	Circulator	H-6AJRD00001	Toshiba	Scanner unit	6AJRD00001
A102	Diode limiter	NJS6930	New JRC	Scanner unit	5EZAA00024
E301	Front end	NJT1028	New JRC	Scanner unit	5EZAA00039

JMA-5106

Model Number	Name	Type	Manufacturer	Location of use	JRC Code
V201	Magnetron	MSF1422B	New JRC	Scanner unit	5VMAA00068
A101	Circulator	H-6AJRD00001	Toshiba	Scanner unit	6AJRD00001
A102	Diode limiter	NJS6930	New JRC	Scanner unit	5EZAA00024
E301	Front end	NJT1969	New JRC	Scanner unit	5EZAA00037

JMA-5110

Model Number	Name	Type	Manufacturer	Location of use	JRC Code
V201	Magnetron	MSF1425B	New JRC	Scanner unit	5VMAA00051
A101	Circulator	H-6AJRD00001	Toshiba	Scanner unit	6AJRD00001
A102	Diode limiter	NJS6930	New JRC	Scanner unit	5EZAA00024
E301	Front end	NJT1969	New JRC	Scanner unit	5EZAA00037

5.5 Circuit Blocks for Repair

NKE-2042

Name	Unit/ type of circuit	Remarks
Modulator circuit	CME-322	
Receiver	CAE-475	
Motor unit	H-7BDRD0023	

NKE-2062

Name	Unit/ type of circuit	Remarks
Modulator circuit	CME-323	
Receiver	CAE-475-1	
Motor unit	CBP-153	

NKE-2102

Name	Unit/ type of circuit	Remarks
Modulator circuit	CPA-248	
Receiver	CAE-475-1	
Motor unit	CBP-167	
Power supply circuit	CBD-1645	

NDC-1260

Name	Unit/ type of circuit	Remarks
Main control circuit	CMC-1190	
Power supply circuit	CBD-1638	
MARPA circuit	CDC-1144	Option

NCE-7640

Name	Unit/ type of circuit	Remarks
Keyboard circuit	CCK-892	

NWZ-146

Name	Unit/ type of circuit	Remarks
LCD unit	H-7WZNA0701	
Power supply unit	CBF-30	

5.6 Actions to Deal with Abnormalities and Breakdown

In the case of semiconductor circuits, except in cases of problems in the design or inspection of such circuits or causes that are external or caused by humans, breakdown or deterioration of the circuit does not often occur. In general, the causes of breakdown that are relatively frequently found are wire cut in the high resistance device due to high humidity, defect in the variable resistance and defect in the contact of switches and relays.

Moreover, in many cases the cause for breakdown is not a defect in parts but rather poor adjustment (particularly inadequate tuning adjustment) or poor maintenance (particularly defect in cable contact) and inspecting or readjusting these aspects is often effective in the case of perceived abnormality or breakdown. The following table should be taken into consideration in the case of abnormalities or breakdown.

There is always a cause for a blown fuse and after replacing the fuse, it is necessary to investigate the related circuits even when no abnormality remains. However, consideration should be given to the fact that there is significant variance in the characteristics of fuses.

No.	Condition of the Breakdown	Conceivable Cause
1	Nothing appears on the LCD.	<ul style="list-style-type: none"> a. Breakdown in the power supply terminal (CBD-1638); Fuse F1 has blown b. Breakdown in the NWZ-146 display c. Breakdown of the main control circuit (CMC-1190) d. The electric power of the ship is inadequate.
2	The scanner unit does not rotate.	<ul style="list-style-type: none"> a. Fuse F2 and F3 have blown. b. Breakdown in the motor unit (JMA-5104: CML-674 H-7BDRD0023 inside the scanner unit, JMA-5106/6110: CBD-153)
3	The scanner unit rotates but no radar image appears (characters and markers are, however, displayed).	<ul style="list-style-type: none"> a. Breakdown of the receiver (JMA-5104: CAE-475, JMA-5106/5110: CAE-475-1) b. Breakdown of the main control circuit (CMC-1190). What is the condition of the transmission trigger (TD)? c. Breakdown in the motor unit (JMA-5104: CML-674 H-7BDRD0023 inside the scanner unit, JMA-5106/6110: CBD-153)
4	The operation switches do not work.	<ul style="list-style-type: none"> a. If the switches do not work even after turning the power on again, breakdown is in the main control circuit (CMC-1190). b. Breakdown is in the panel circuit (CCK-892) c. Cut in the cable connecting the operation unit. (H-7ZCNA0855)

Chapter 6 After-sales Service

★ When asking for repair

When a system failure is suspected, read Chapter 4, 5 and 9 carefully and re-check the abnormal part.

If it is still considered to be a failure, stop the operation at once and consult with the dealer you purchased the product, our sales department or your nearest branch or business office.

● Repair within the warranty period

If the failure occurred under proper operation in accordance with the instruction manual, the dealer or JRC shall repair the product without charging. In case of any other failure occurred due to mis-operation or natural disaster, the repair work will be charged.

● Repair after the warranty period has expired

If the product is recoverable by repairing, we will repair it upon your request.

● Items to be identified

- ☆ Product name, model name, manufacturing date and serial number
- ☆ Failure condition (as detailed as possible: see the Radar Failure Checklist on next page.)
- ☆ Your company/organization name, location and telephone number

★ Recommendation of maintenance inspection

Although it depends on your operating condition, the performance of the product may be lowered due to parts wear.

We recommend maintenance inspection, apart from the normal maintenance work.

For maintenance inspection, consult with the dealer you purchased the product, our sales department, or your nearest branch or business office.

Note that this maintenance inspection will be charged.

For detail of after-sale service, contact the dealer you purchased the product, our sales department, or your nearest branch or business office.

☞ Contact : See the list at the end of the manual.

RADAR FAILURE CHECKLIST

When ordering for repair, check the following items, fill in the sheet and send it to us.

If there is any uncertain items, contact your ship and give us correct information on the product.

Ship name : _____ Phone : _____ Fax : _____

Radar general model name : JMA-_____ Serial No. : _____

(Write the full model name correctly)

(1) Check the following items in the order of the number, and circle the applicable answer between YES or NO.

If the item cannot be determined as YES or NO, explain in detail in the item (15), Others.

(2) If any of the items (1) through (4) is marked as NO, check the fuse of the product (refer to Section 5.6 and 9.4).

(3) Check the items (4) through (14) while the transmission (TX) is ON.

* Functions mentioned in the items (13) through (14) may be optional. If the function is optional, answer is not necessary.

No.	Check Item	Result	
		YES	NO
(1)	Power can be turned on. (The lamp on the keyboard is lit.)	YES	NO
(2)	A few minutes after powering-on, it will become stand-by status (TX Ready).	YES	NO
(3)	When powering-on (or TX ON), the LCD displays something (LCD is lit).	YES	NO
(4)	The scanner unit rotates at the transmission (X-MIT) ON. (Check the following items while transmission is ON.)	YES	NO
(5)	Tuning is enabled. (Check with the range of 6NM or more.)	YES	NO
(6)	Fixed marker is displayed.	YES	NO
(7)	VRM is displayed.	YES	NO
(8)	White noise is displayed while set at SEA, RAIN minimum, GAIN maximum, IR-OFF and maximum range.	YES	NO
(9)	Target reflection echo is displayed.	YES	NO
(10)	Sensitivity of reflection echo is normal.	YES	NO
(11)	EBL is displayed.	YES	NO
(12)	Cursor mark moves.	YES	NO
*(13)	GYRO course can be set and normally displayed.	YES	NO
*(14)	LOG speed can be normally displayed.	YES	NO

(15) Others (Error message, etc) _____

Chapter 7 Disposal

7.1 Equipment Disposal

Dispose of this equipment by following the ordinances or regulations of the local authorities in charge of the disposal site.

7.2 Disposal of Used Batteries

WARNING



Before disposing of used lithium batteries, insulate by affixing tape to the positive and negative terminals or by other means. Otherwise, short-circuiting may occur, resulting in heat generation, bursting or ignition.

On this equipment, lithium batteries are used for :

BT1 in the CPU control circuit (CMC-1190) (Sanyo electric CR2477-1VC).

- Do not keep used lithium batteries but dispose of them immediately after as non-combustible waste.
- Before disposing of used lithium batteries, insulate by affixing tape to the positive and negative terminals or by other means. In the area where used batteries are separated from other waste, dispose of them by following the local regulations.

7.3 Disposal of Used Magnetron

The scanner unit in this radar use a magnetron.

- After replacing it, return the used one to your local distributor or our sales office. For detail, ask your local distributor or our sales office.

Chapter 8 Specifications

8.1 General Specifications

1) Picture	Color PPI by raster scan system Resolution : 640 x 480 pixels
2) Display screen	10.4-inch TFT Color LCD
3) Range scale	<JMA-5104> 0.125nm, 0.25nm, 0.5nm, 0.75nm, 1.5nm, 3nm, 6nm, 12nm, 24nm, 48nm <JMA-5106 / JMA-5110> 0.125nm, 0.25nm, 0.5nm, 0.75nm, 1.5nm, 3nm, 6nm, 12nm, 24nm, 48nm, 72nm
4) Minimum range	Better than 25m
5) Range discrimination	Better than 25m
6) Bearing accuracy	Better than 1°
7) Bearing representation	Relative, or true with a compass
8) Environmental condition	<Temperature> Scanner unit : -25 °C to +55 °C Display unit : -15 °C to +50 °C <Relative humidity> Scanner unit : 93% maximum at +40 °C Display unit : 93% maximum at +40 °C
9) Tolerance of input voltage	<JMA-5104 / JMA-5106> DC 12V/24V/32V (from DC 10.8 to 42V) <JMA5110> DC 24V/32V (from DC 21.6 to 26.4V) AC 100/110/115/200/220/230V ± 10% (by rectifier unit)
10) Power consumption	<JMA-5104> 70W <JMA-5106> 85W <JMA-5110> 100W
11) Preheating time	90 seconds
12) Dripproof	Scanner unit IPX6 Processing unit/Keyboard unit IPX2 Display unit IPX5
13) Vibrations	ICE60945
14) Language	English, French, Spanish, Norwegian, Italian, Danish, Japanese

8.2 Scanner Unit Specification

8.2.1 Scanner unit (NKE-2042 : Redome type)

1) Dimensions	Height : 275mm, Diameter of radome : 620mm
2) Mass	Approx. 10.5kg
3) Polarization	Horizontal
4) Beam width	
Horizontal (-3dB)	4°
Vertical (-3dB)	25°
Side lobe level	Less than -21dB within 10° of main beam
5) Rotation speed	Approx. 27rpm
6) Frequency	9410 ± 30MHz
7) Peak power	4kW
8) Pulse length/repetition frequency	0.08μs/2250Hz : 0.125nm, 0.25nm, 0.5nm, 0.75nm, 1.5nm(S) 0.25μs/1700Hz : 1.5nm(L), 3nm(S) 0.5μs/1200Hz : 3nm(L), 6nm(S) 1.0μs/650Hz : 6nm(L), 12nm, 24nm, 48nm (S: Short, L: Long)
9) Modulator	Solid-state modulator
10) Duplexer	Circulator/diode limiter
11) Front end module	Built in
12) IF amplifier	Logarithmic amplifier, Noise figure 6dB maximum.
13) Tuning	Manual/Auto

8.2.2 Scanner unit (NKE-2062 : 6kW rotation type)

1) Dimensions	Height : 432mm, Swing circle : 1220mm
2) Mass	Approx. 24kg
3) Polarization	Horizontal
4) Beam width	
Horizontal (-3dB)	2°
Vertical (-3dB)	30°
Side lobe level	Less than -23dB within 10° of main beam Other than -26dB within 10° of main beam
5) Rotation speed	Approx. 27rpm
6) Frequency	9410 ± 30MHz
7) Peak power	6kW
8) Pulse length/repetition frequency	0.08μs/2250Hz : 0.125nm, 0.25nm, 0.5nm, 0.75nm, 1.5nm(S) 0.25μs/1700Hz : 1.5nm(L), 3nm(S) 0.5μs/1200Hz : 3nm(L), 6nm(S) 1.0μs/650Hz : 6nm(L), 12nm, 24nm, 48nm, 72nm (S: Short, L: Long)
9) Modulator	Solid-state modulator
10) Duplexer	Circulator/diode limiter

11) Front end module	Built in
12) IF amplifier	Logarithmic amplifier, Noise figure 6dB maximum.
13) Tuning	Manual/Auto

8.2.3 Scanner unit (NKE-2102 : 10kW rotation type)

1) Dimensions	Height : 448mm, Swing circle : 1910mm
2) Mass	Approx. 24kg
3) Polarization	Horizontal
4) Beam width	
Horizontal (-3dB)	1.2°
Vertical (-3dB)	20°
Side lobe level	Less than -26dB within 10° of main beam Other than -30dB within 10° of main beam
5) Rotation speed	Approx. 27rpm
6) Frequency	9410 ± 30MHz
7) Peak power	10kW
8) Pulse length/repetition frequency	0.08μs/2250Hz : 0.125nm, 0.25nm, 0.5nm, 0.75nm, 1.5nm(S) 0.25μs/1700Hz : 1.5nm(L), 3nm(S) 0.5μs/1200Hz : 3nm(L), 6nm(S) 1.0μs/650Hz : 6nm(L), 12nm, 24nm, 48nm, 72nm (S: Short, L: Long)
9) Modulator	Solid-state modulator
10) Duplexer	Circulator/diode limiter
11) Front end module	Built in
12) IF amplifier	Logarithmic amplifier, Noise figure 6dB maximum.
13) Tuning	Manual/Auto

8.3 Processing Unit Specifications

1) Dimensions	Width : 300mm Height : 125mm Depth : 210mm
2) Mass	Approx. 2.4kg
3) Installation	Floor setting type
4) Range scale/rings	0.125nm/0.065nm, 0.25nm/0.125nm, 0.5nm/0.1nm, 0.75nm/0.25nm, 1.5nm/0.5nm, 3nm/0.5nm, 6nm/1nm, 12nm/2nm, 24nm/4nm, 48nm/8nm, 72nm/12nm(except JMA-5104)
5) Range accuracy	Better than $\pm 1.5\%$ of maximum range in use or $\pm 70\text{m}$ whichever is greater
6) Bearing scale	360° scale graduate at intervals of 1°
7) Ship's heading marker	Electronic line suppressible by automatic resetting key.
8) EBL(EBL1/EBL2)	Digital read-out on the screen (3 characters)
9) VRM(VRM1/VRM2)	Digital read-out on the screen (3 characters)
10) Off-centering	90% of the picture radius
11) Trails	OFF/30 to 59sec/1 to 59min/continuous Mode 1 : OFF Mode 2 : Timing trail display Mode 3 : Continuous trail display Mode 4 : Timing trail display and continuous trail display
12) Indication on the screen	Selected range Selected range ring distance Motion mode/azimuth mode Interference rejection indication Echo stretch Wakes time Speed/Course indication Guard zone mode STC/FTC mode Pulse Tuning indicator Own position (lat./lon.) EBL1/EBL2 read-out (3 characters) VRM1/VRM2 read-out (3 characters) Cursor read-out (Bearing and range / or lat./lon.) TX/ST-BY indication
13) Color	
Radar echo	
Gradation	16 level
Color	4 colors (yellow, green, orange, color)

Radar trails	
Gradation	1 level (time wakes, continuance, trails)
Color	Time trails : 3 colors (sky, white, green) Continuance trails : 3 colors (sky, white, green)
Fixed marker / VRM1/2 / EBL1/2	
Color	cyan
Character	
Color	white
Heading line/cursor	
Color	white
Background color inside PPI	black, blue, gray
Background color outside PPI	black, blue, gray
14) Heading	Head up/North up/Course up
15) Motion	Relative motion/True motion/Centerd true motion
16) Guard zone alarm	Can be switched between "OFF", "IN" and "OUT"
17) Anti-clutter function	Anti-Clutter sea : Manual/Auto Anti-Clutter rain : Manual/Auto
18) Scan correlation function	Built in
19) Floating EBL	Built in
20) Echo stretch function	Built in
21) Parallel index	Built in
22) Zoom function	Built in
23) Timed TX	TX : 1 to 99 rotation ST-BY : 1 to 99 minutes
24) Cable length	20m (standard) 30m (option) : DC 24V in only
25) Interface	
Power in	Ship's main
Inputs signal	GPS or GPS receiver GPS compass or electronic compass GYRO (need NSK unit : option) NMEA data (need GPS data) Cursor position (RSD) Own data (OSD) MARPA target data (TTM) with optional MARPA pcb Ext buzz
26) Output	

8.4 Keyboard Unit Specifications

1) Dimensions	Width : 290mm Height : 45mm Depth : 123mm
2) Mass	1.0kg
3) Controls and keys	Gain control Tuning control Anti-clutter sea control Anti-clutter rain control Power on/STBY switch (ON/OFF) X-MIT key MOB key EBL key (ON/OFF/SELECT) VRM key (ON/OFF/SELECT) Dimmer key Alarm ack key Function key Off center key TM/RM key Trails key Bearing key Range ring key Cursor position key Data key Clear key Range scale key (UP and DOWN) Menu key Acq/Enter key
4) Track ball	Built in
5) Cable length	5m

8.5 Display Unit Specifications

1) Dimensions

Landscape

Width : 290mm

Height : 290mm

Depth : 165mm

Portrait

Width : 230mm

Height : 325mm

Depth : 165mm

2) Mass

2.8kg

3) Power

DC 12V in

4) Resolution

640 x 480 pixels input signal

5) Signal impedance

Video (R, G, B) : 75 Ω

Sync horizontal : 1k Ω

Sync vertical : 1k Ω

6) Cable length

5m

8.6 Option

8.6.1 Interunit cable

Interunit cable | 30m

8.6.2 Rectifier unit

Rectifier unit | NBA-797

8.6.3 Flash mounting kit

- 1) Flash mounting kit (For display unit) | MPTG31339
- 2) Flash mounting kit (For keyboard unit) | MPTG31340

8.6.4 MARPA

MARPA	NCA-868
1) Acquisition	
Acquisition mode	Manual (10 targets max)
Manual canceling of unnecessary target	By 1 target each or all targets
Tracking range	0.1 to 20NM
2) Tracking	
Tracking mode	Automatic
3) Vectors	
Mode	Relative/True
Length	1 to 99minutes
4) Dangerous target limits	
CPA	CPA 0,0 to 9.9NM
TCPA	TCPA 0 to 99minutes
5) Numbering target	Automatic or manual applied
6) Numerical display	
Target Data	Simultaneous and continuous display for 1 target. True Bearing (3 digit), Range (3 digit), True course (3 digit), True speed (3 digit), CPA, TCPA
7) Collision point	Calculate predicted collision point for 1 target collision course Estimated time to collision

8.6.5 NSK unit

NSK UNIT	NCT-4106
Gyro	
SYNC/PULSE	360X, 180X, 90X and 36X
Log	
SYNCHRO	360X, 180X, 90X and 36X
PULSE	800, 400, 200 and 100

8.6.6 Sub indicator unit signal out

Signal | Trigger, video, bearing pulse and reference pulse

8.6.7 Sub keyboard unit

Sub keyboard unit | NCE-7640

8.7 Rectifier

NBA-797

1) Dimensions	Width : 270mm Height : 430mm Depth : 175mm
2) Construction	Waterproof construction of wall tapestry type
3) Mass	Approx. 18kg
4) Tolerance of input voltage	AC 100/110/115/200/220/230V $\pm 15\%$ 50/60Hz, single phase
5) Power consumption	200VA
6) Output	DC 26, 7A

8.8 Cable Length between Equipment Units

	Maximum cable length	Standard cable length
1) From scanner unit to indicator unit	30m	20m
* In case of JMA-5104 or JMA-5106, the input voltage beyond 24V is required for 30m.		
2) From indicator unit to rectifier unit	2m	2m
3) From indicator unit to keyboard unit	5m	5m
4) From indicator unit to display unit	5m	5m

Chapter 9 Installation

This chapter has been written for the service technicians to read in case of installation.

WARNING



Only specialized personnel shall perform installation work. Installation work performed by personnel other than specialized personnel may cause breakdown of the equipment, poor performance, fire, severe electric shock and other property and human damages.

9.1 General

Proper installation of a radar unit is essential for extracting full capability of the unit reliably and for facilitating troubleshooting and maintenance. Follow the guidelines given below when installing the radar unit.

- (a) Install the scanner unit as high as possible while taking its weight into consideration.
- (b) Install the display unit in the wheel house for comfortable observation.
- (c) The scanner unit and display unit are connected by 20m compound cable with an internal shield. The maximum permissible cable length is 30 m (only when DC 24V or DC 32V is input). Cables longer than 30m will deteriorate the radar performance of the radar unit.

9.2 *Installing the Scanner Unit*

9.2.1 Selecting the installation location

CAUTION



The scanner unit shall be installed where there are not large obstacles in the direction of the ship's heading line in the same plane.

If there is a large impediment in the same plane as the scanner unit, this may cause the generation of false echoes. In particular, if such false echoes appear at the ship's heading line, monitoring will be difficult and this may cause inadequate forecasting of danger.



Do not install the scanner unit near chimney's or the exhaust of chimneys.

Soot will cause the performance of the radar to decrease and heat may cause breakdown.



Do not install direction antenna or VHF antenna in the vicinity of the scanner unit. Doing so may cause noise in the antenna reception.



Consideration should be given to separating the radar cable from the cables for the direction antenna and VHF antenna.

These cables should never be bundled into one. Doing so may cause noise in the antenna reception.

Take the following into consideration when selecting the installation location:

- (1) Consider the weight of the scanner unit and decide what height it can be raised for installation in the ship.
- (2) Height at which the scanner unit is installed has to do with the maximum detectable range, the higher its position is the better. On the other hand, however, if raised too high, at a point beyond the beam width (-3 dB position) along the vertical direction radio wave energy will be affected noticeably, making it difficult to spot targets lying very near.

When installing the unit, consider its weight, longest permissible cable length, and the requirements during future maintenance.

Refer to 4.1, "Height of and the Distance to the Target" for the relation between the height of the scanner unit and maximum detectable range.

- (3) If the width of the radiated beam is 2θ (most energy is concentrated within this width), then the energy reduces considerably in directions outside the 2θ range. Thus, if the scanner unit is raised too high it will be difficult to spot targets lying very close-by. If, on the other hand, the scanner unit is installed low, it will be obvious to miss distance targets, and the ship's mast derrick, funnel, etc. will intercept the radiated beams, making most of your targets unobservable. In general, the lowest position of the scanner unit should be as shown by the line AB in the following figure. For example, angle 2θ is 20° for the radar of JMA-5110.

Normally, when deciding the height of the scanner, it is necessary to make sure that the ship's mast does not obstruct the beams.

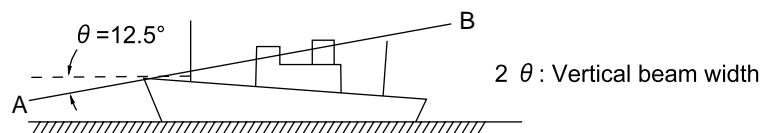

Lowest Position of Scanner Unit

- (4) When selecting the position of the scanner along the length of the ship, make sure that the shading caused by the ship's mast on the radio waves does not coincide with the ship's center line. If the ship has no large obstruction towards front, normally the scanner is placed on top of the steering room along the ship's center line.
- (5) Avoid placing DF (direction finder) of VHF (communications) antenna near the scanner as these will interfere with the radiated waves.
- (6) Soiling of the radiating surface of the scanner by the smoke from funnel affects radar performance, clean the radiating surface form time to time. To facilitate maintenance, place the scanner in the right position and use mast and tower of the right structure.
- (7) Note that, if placed near ship's flag or rope may cause by wind to wrap or coil around the radiator and damage it.
- (8) Do not select the derrick post as the location for scanner installation. The derrick post is subject to large vibrations.

- (9) Note the swing circle of the scanner and allow a distance of at least $(\text{swing circle}/2)+200$ mm between scanner swing center and other installations (say, mast or radio antenna).

Scanner swing circle in the radar of JMA-5106/5110 is shown in the following table.

Scanner unit	Feet	Swing circle (mm)	Swing circle/2+200 (mm)
NKE-2062	4	1220	810
NKE-2102	6	1910	1155

9.2.2 Installation procedure

- (a) If it is found that there is no height above the roof of the wheel house enough to directly accommodate a scanner unit, install a pedestal or radar mast.
- (b) In addition to a pedestal or radar mast, it is necessary to provide an appropriate staging for convenience in installation, maintenance, adjustment, and repair of the scanner unit.

1. Stand

Install the stand as instructed in drawing Fig.1.1, 1.2 and 1.3 in Chapter 1. Direct the cable gland towards ship's stern, making sure that scanner installation base is parallel to surface of the sea. If the stand is installed directly on the top of steering room and find that the scanner is not sufficiently high, use a pedestal or radar mast. Normally, if height of the scanner is not more than 2 m above the roof of the steering room, place the scanner on a pedestal fixed with angle joints. If, on the other hand, the scanner is positioned below a height of 2 m, use a cylindrical radar mast, and place the scanner on top of it. Whether a pedestal or radar mast is used it is necessary to provide proper foothold to facilitate the installation, maintenance, adjustment, and repairs. (Refer to the following figure)

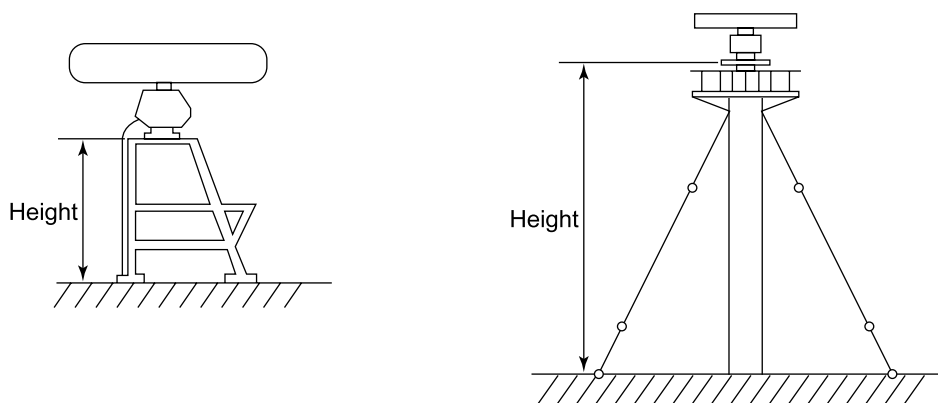

Scanner Stand

2. Suspending the Scanner

The scanner is supplied assembled, with felt wound around the area where the suspension rope will contact it. Engage the sling with the scanner as shown in the following figure.

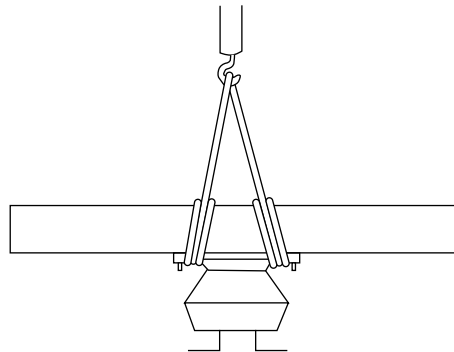

Scanner Suspension

CAUTION



If felt is not provided where the rope contacts the scanner, or if the scanner is supported near the both ends of the radiator, you may damage the unit. Be sure to apply the rope to the antenna support.

3. Paint

Apply necessarily paint on the fixing legs, bolts, nuts, etc. to prevent corrosion.

4. Magnetism

Place the scanner at least 3m away from the nautical instruments such as the compass or the chronometer to protect these from the effect of the magnetron inside the scanner.

9.2.3 Connection of cables to be assembled

1. Radome scanner unit (NKE-2042)

ASSEMBLING PROCEDURE FOR CABLE

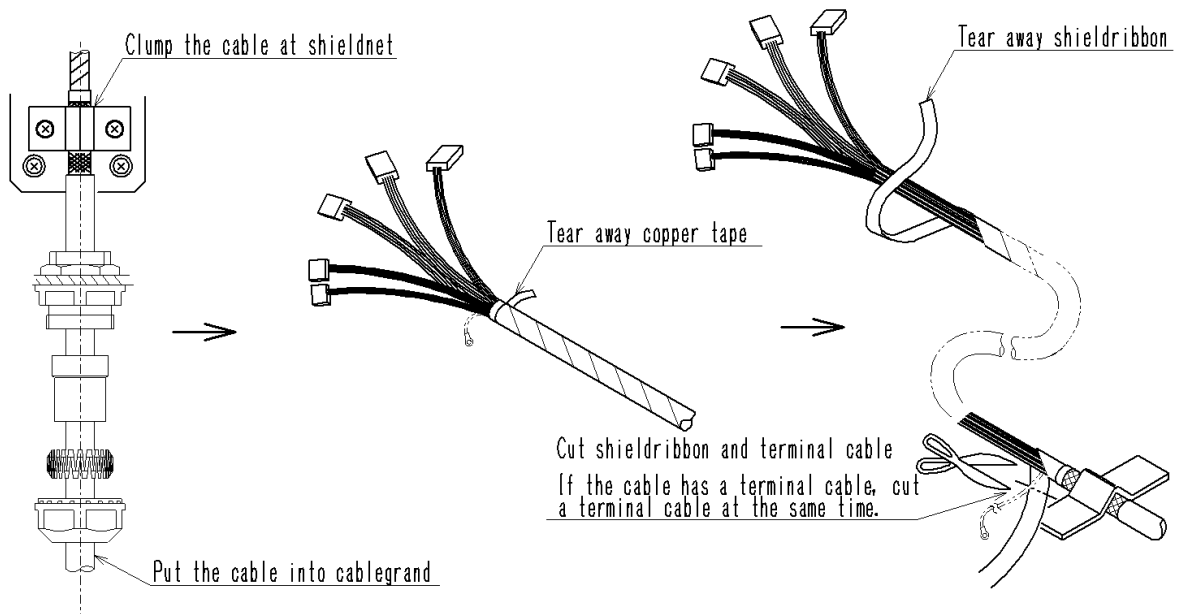
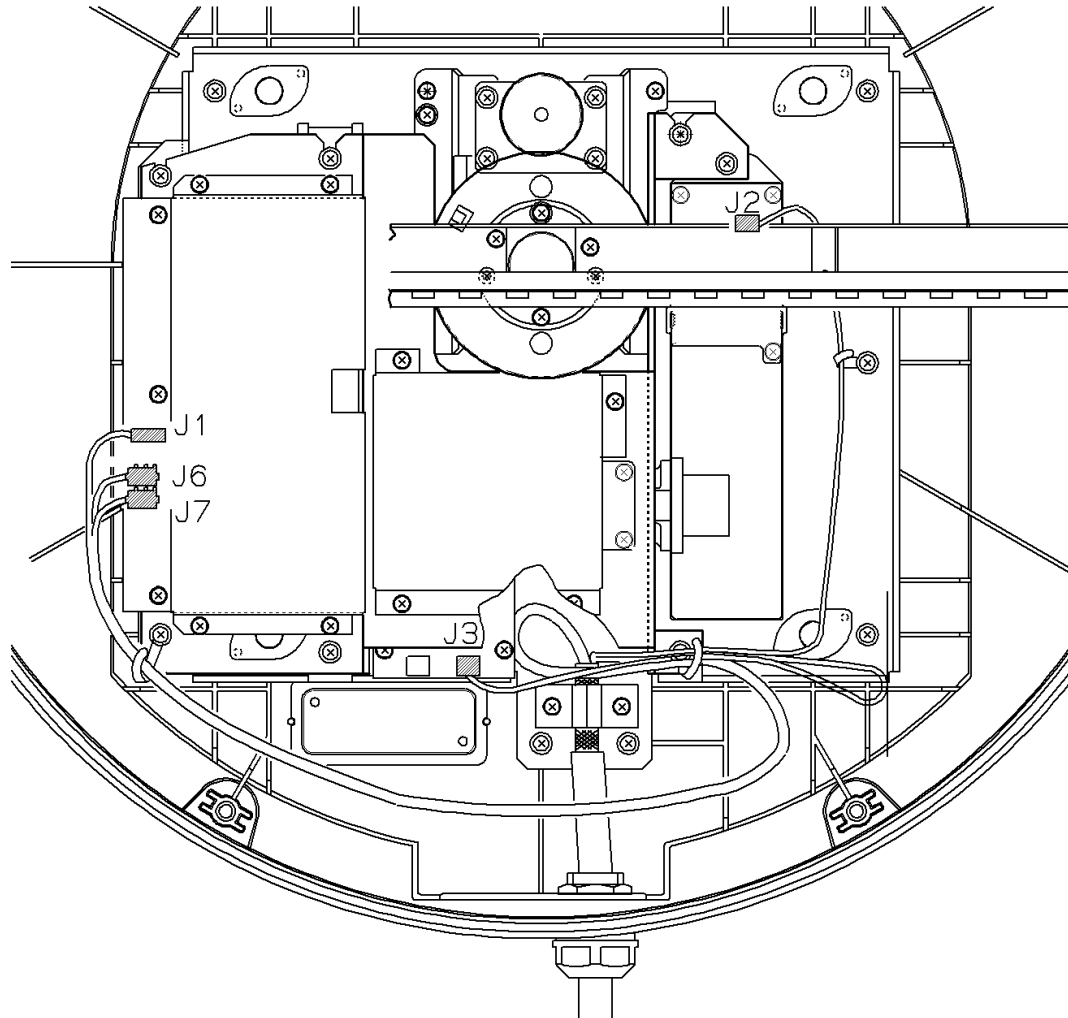

⚠ CAUTION



When mounting the scanner unit, please check the maximum length of the holding bolts.

If the bolts are too long, it gives severe damage to inside of the scanner.

When mounting the scanner unit, please use the attached bolts.

The mounting base thickness must not exceed 15mm (0.6inch).

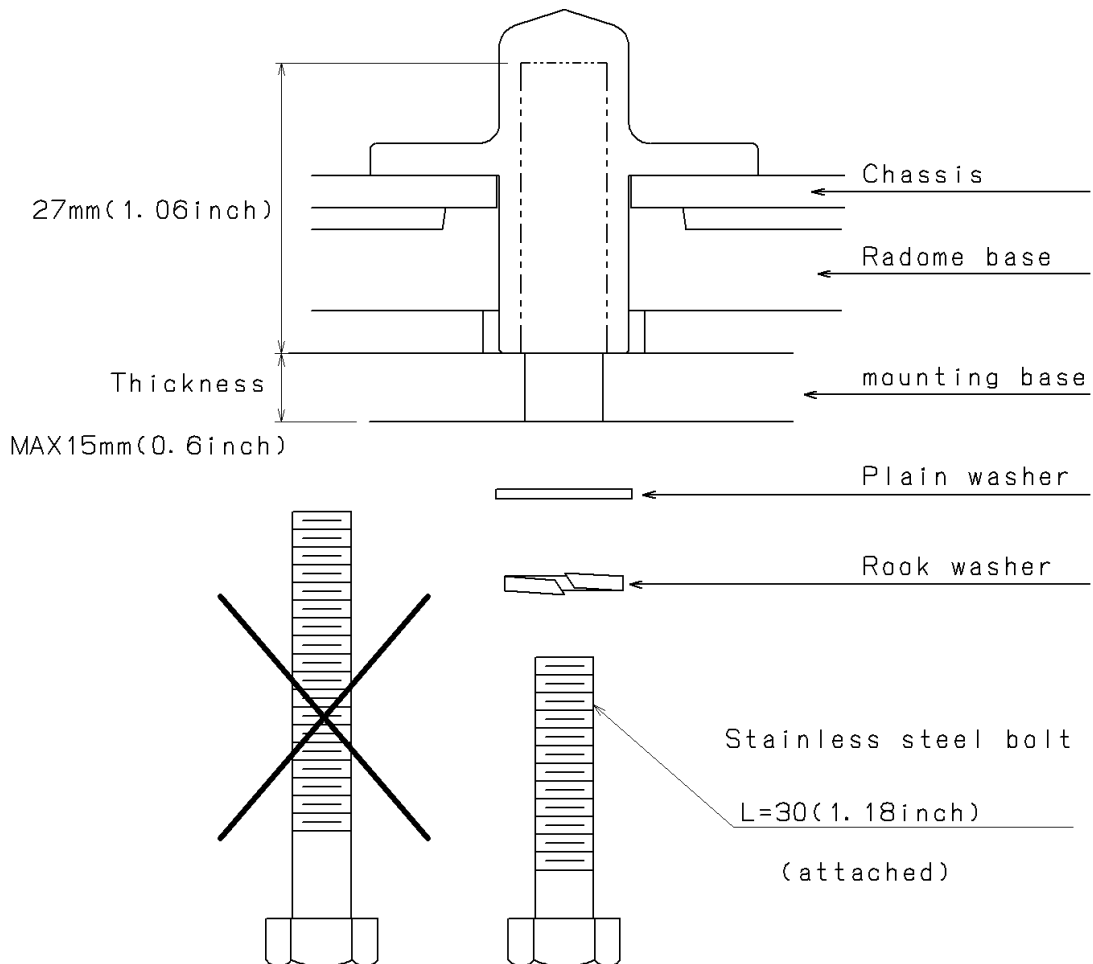

※FIX THE BOLTS BY USING A STANDARD WRENCH (LENGTH 135mm)
(TORQUE 2058N-cm)

2. Rotary scanner unit (NKE-2062/NKE-2102)

Instruction for equipment

1. Put the cable into cable grand, washers and gasket.
Tear away the tape.

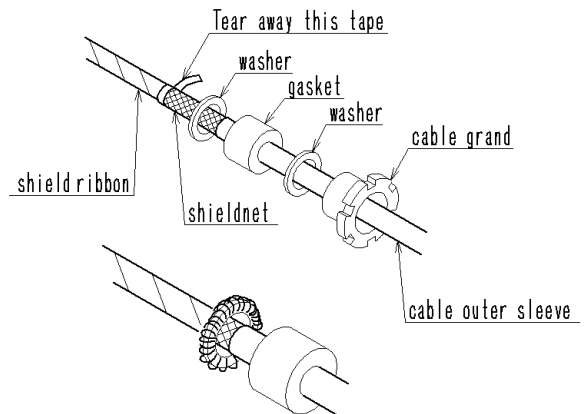

2. Unknit shieldnet and wrap it around a washer.

3. Equip the scanner unit with brass-washers: apperded.

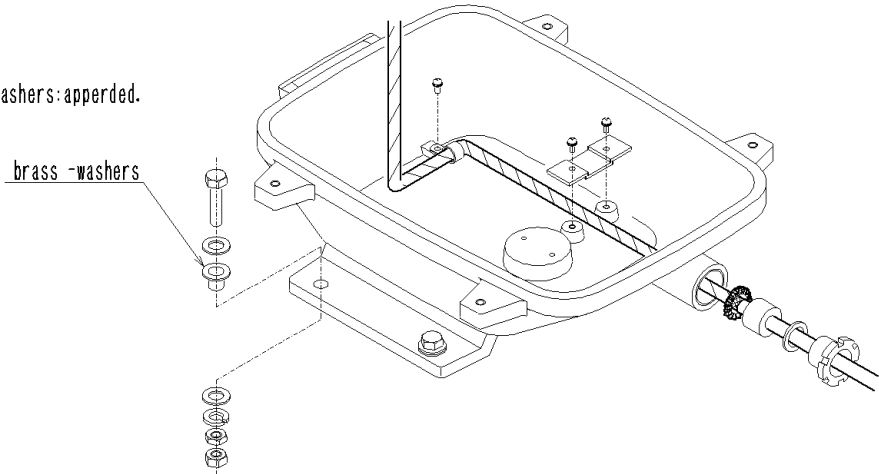

4. Clump the cable, connect 5 connectors.
If the cable has the terminal line, connect a terminal.

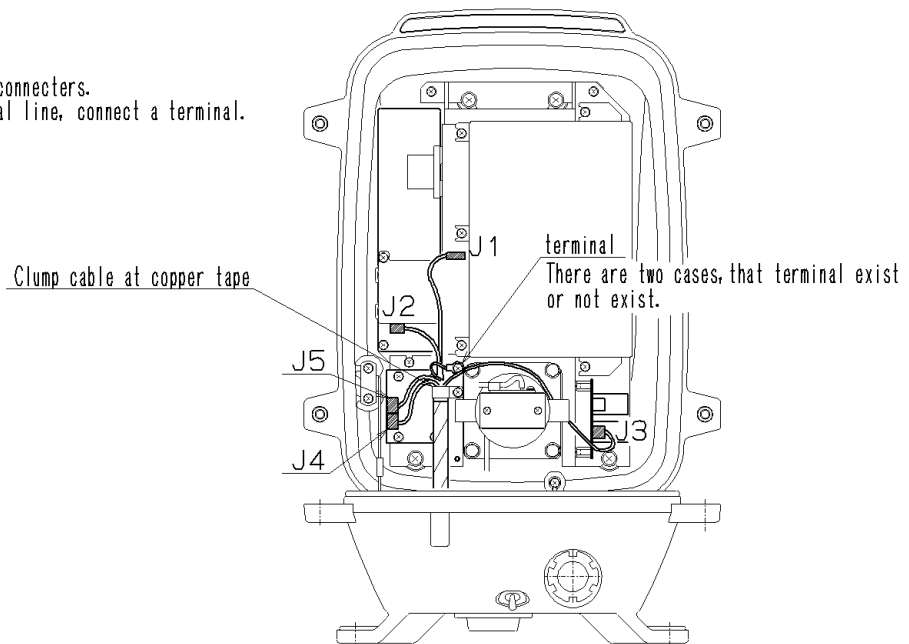

5. Apply silicone sealant around the bolts and into the cable inlet.

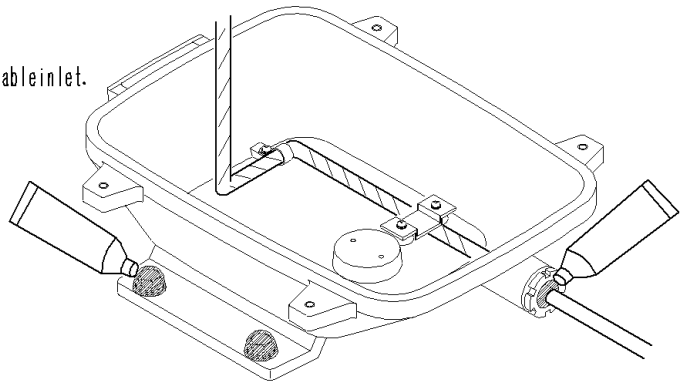

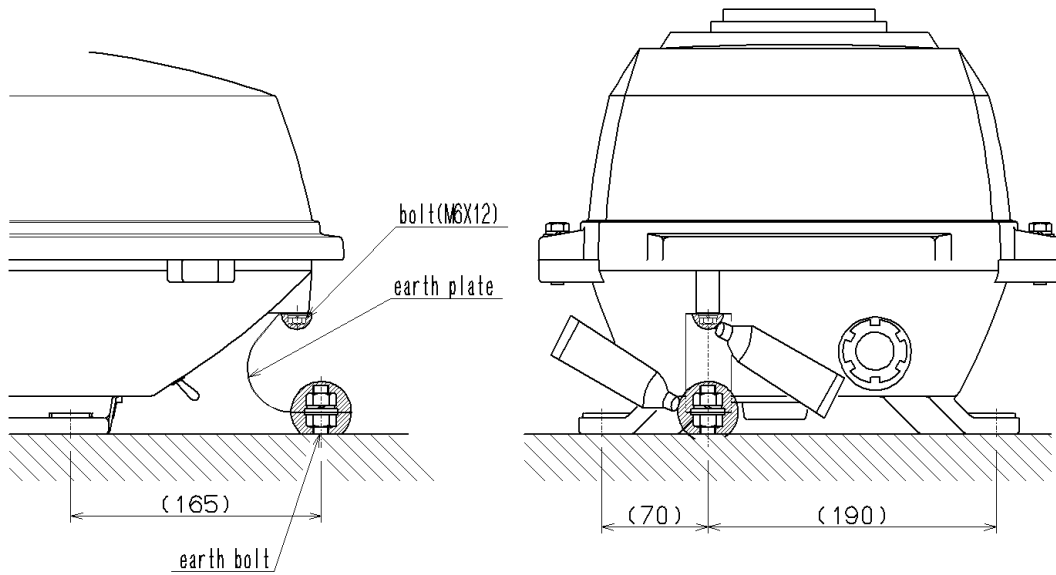

6. Bolt the earth plate to mountbase and scanner.
Apply silicone sealant around the bolts.



9.3 *Installing an Indicator Unit*

9.3.1 Specifying the installation position

 CAUTION	
	Provide a distance of 1m or more between a processing unit and a magnetic compass. If a processing unit is installed in a position too close to a magnetic compass, it may affect the magnetic compass.
	Install a processing unit in the location that is not affected by seawater. The processing unit is not waterproof.

An indicator unit comprises the following three components.

Processing unit NDC-1260 : Box of an A4 size

Keyboard unit NCE-7640 : Keyboard with knobs or keys

Display unit NWZ-146 : LCD display unit that is packed separately from a processing unit and a keyboard unit

9.3.2 Installation method

- (a) Install an indicator unit in such a way that can be observed by users easily.
- (b) Install the indicator unit giving consideration to maintenance after installation.

9.3.3 Rear of the processing unit

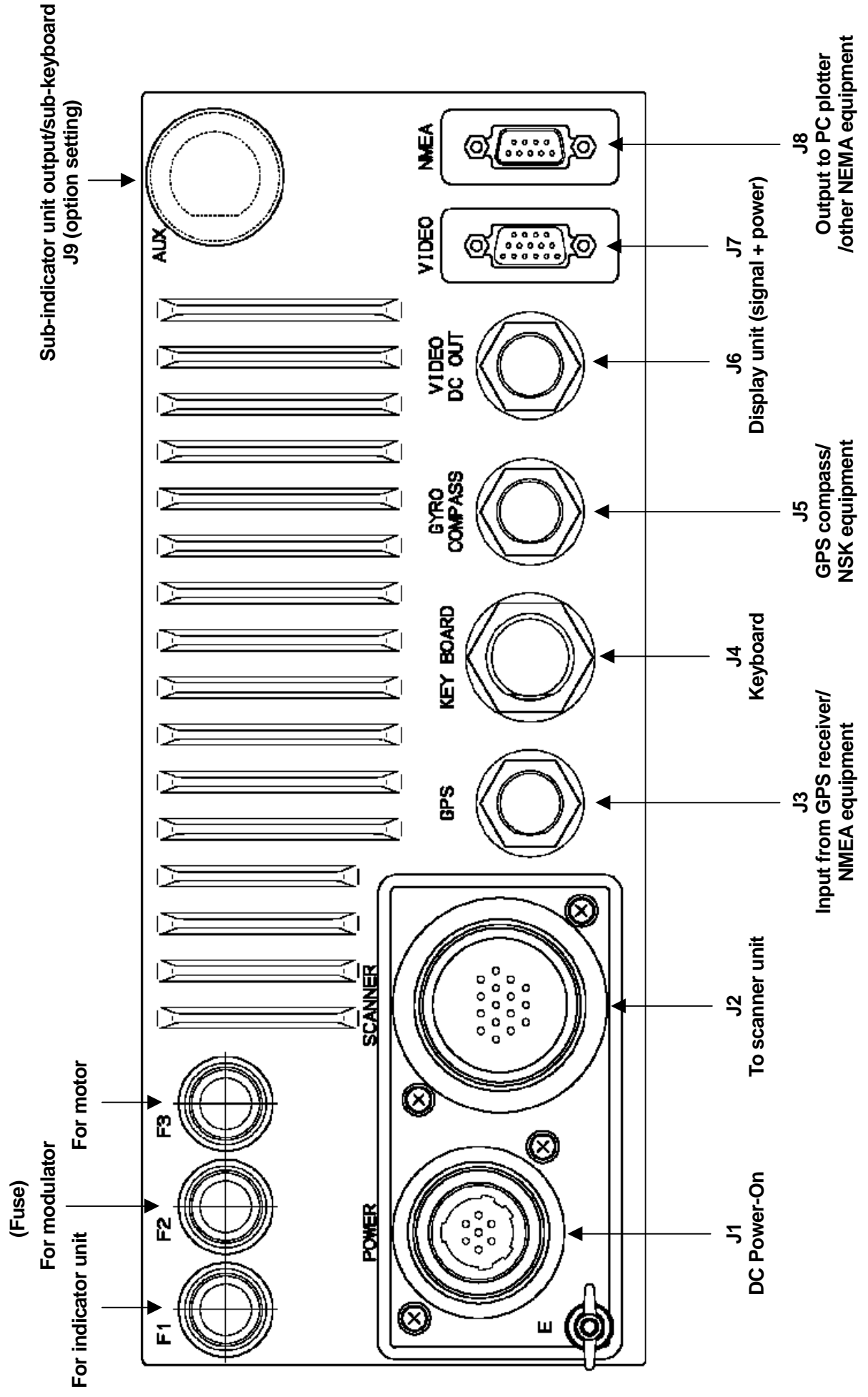

9.3.4 Signals of option connectors

GPS connector (J3)

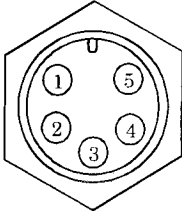

To GPS or NMEA equipment

- (1) +12V : Power for GPS receiver
- (2) GND : Power GND for GPS receiver
- (3) NAVCOM : Signal GND
- (4) NAVRX : Input from receiving signals from GPS
- (5) NAVTX : Output of transmitting signals to GPS

Connector for GPS compass/NSK equipment (J5)

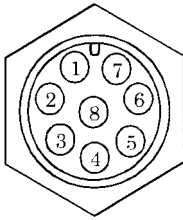

To GPS compass or NSK unit

- (1) NSKTX- : Output of receiving signals from NSK+
- (2) NSKTX+ : Output of receiving signals from NSK-
- (3) NSKRX+ : Input of receiving signals from NSK+
- (4) NSKRX- : Input of receiving signals from NSK-
- (5) GND : Power GND for NSK
- (6) ALM+ : Dry contact output 1
- (7) ALM- : Dry contact output 2
- (8) +5V : Power for NSK (+5V)

Use the following plug connectors, P3 and P5, for J3 and J5.

Connector	Type	JRC code
P3 (for J3)	LTWD06BFFA-L180	5JCDX00014
P5 (for J5)	LTWD08BFFA-L180	5JCDX00015

Connector for signal output to PC plotter/NMEA equipment (J8)

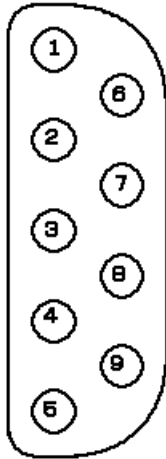

To PC plotter or NMEA equipment

(1) NC	: Unused
(2) RSRXD	: RXD signal input (reserved)
(3) RSTXD	: NMEA signal output
(4) NC	: Unused
(5) GND	: Signal GND
(6) NC	: Unused
(7) RSRTS	: RTS signal output (reserved)
(8) RSCTS	: CTS signal input

(2) RSRXD and (7) RSRTS are used for special purposes.

NMEA signals are output from (3) RSTXD and RS232C output is set at short circuit between 1 and 2 of power terminal block jumper TB1, and RS422 (NEMA0183) is set at short circuit between 2 and 3. To connect J8 and a PC plotter (RS232C port), use a commercial cross type DSUB9-pin cable (for RS232C).

To connect J8 to different NMEA equipment, also obtain a commercial DSUB9-pin connector.

In this case, make sure that the jumper of power terminal block TB1 is set between 2 and 3 (RS422 level).

9.3.5 Installing and display unit

Display unit NWZ-146 is connected with two cables.

1. Setting vertically or horizontally

A display unit can be installed vertically or horizontally.

When changing the orientation of a display unit from vertically to horizontally or vice versa, remove the four small screws from the rear of the display unit and install it with the required orientation as shown below.

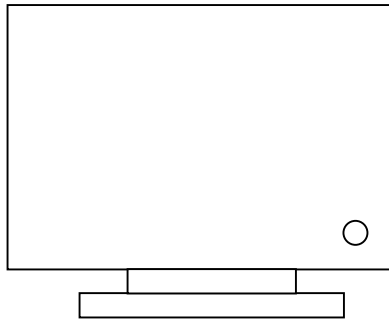

Horizontal installation

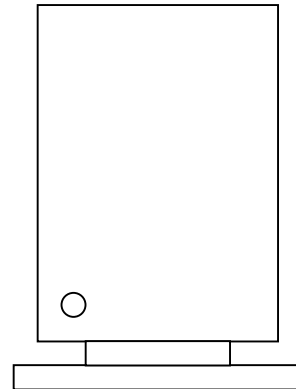

Vertical installation

(o: Brightness adjustment knob)

2. Connecting cables

Connect two cables from the processing unit.

One cable is used as a video cable and the other is used as a power cable. As shown in the photograph below, insert the two cables at the rear of the display unit, turn the plugs until they stop, and check that the cables do not come off even if they are pulled.



Connection on the display unit side :
Make sure that the cables do not come off even if they are pulled.

Connect two cables from the processing unit.

As shown in the photograph below, insert the power cable connector at the rear of the processing unit and turn the plug until it stops, and check that the cable does not come off even if it is pulled.

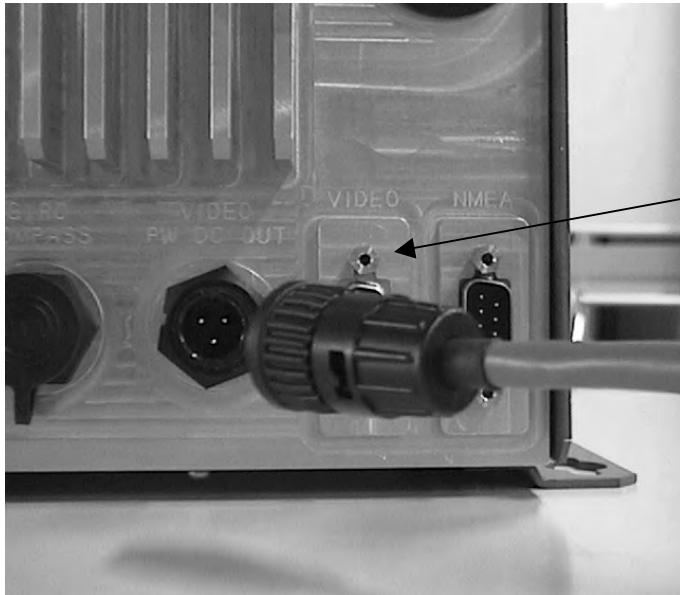

Connection 1 of the processing unit:
Power cable
Check that the cable does not come off even if it is pulled.

Insert the signal cable at the rear of the processing unit, turn the two knobs with plugs until they stop, and check that the cable does not come off even if it is pulled.

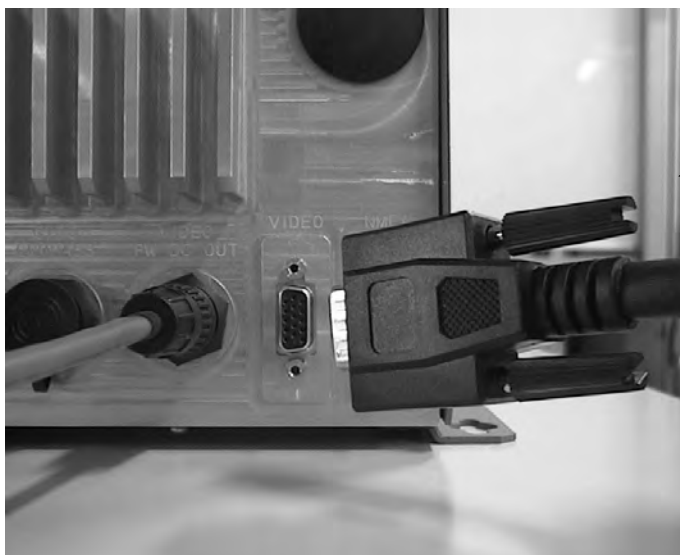

Connection 1 of the processing unit:
Signal cable
After inserting a signal cable, fix the cable firmly by turning the knob of the cable until it stops. Check that the cable does not come off even it is pulled.

9.3.6 Installing a keyboard unit

A keyboard unit can be installed at any location within a distance of 5m with a processing unit.



The cable is attached to the keyboard unit.

Connecting a cable

Connect one cable to a processing unit.

Turn the insertion plug at the rear of the processing unit to the full position and check that the cable does not come off even if it is pulled.

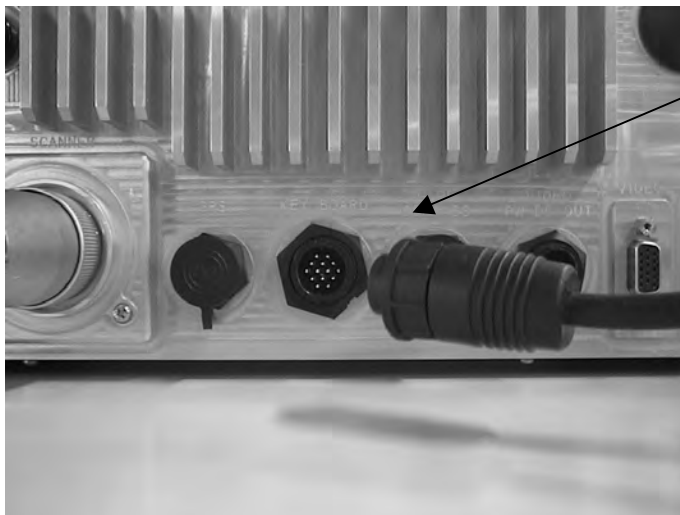

Check that the cable does not come off even if it is pulled.

9.3.7 Attaching a power cable (CFQ-6911-5)

A power cable of 5m length with a connector is attached to this radar equipment.

Color	Number of element wires/ diameter (mm)	Cross section (mm ²)	Polarity
Red	50/0.18	1.25	+
Red	50/0.18	1.25	+
Red	50/0.18	1.25	+
Black	50/0.18	1.25	-
Black	50/0.18	1.25	-
Black	50/0.18	1.25	-



CFQ-6911-5 cable
Cable length 5m

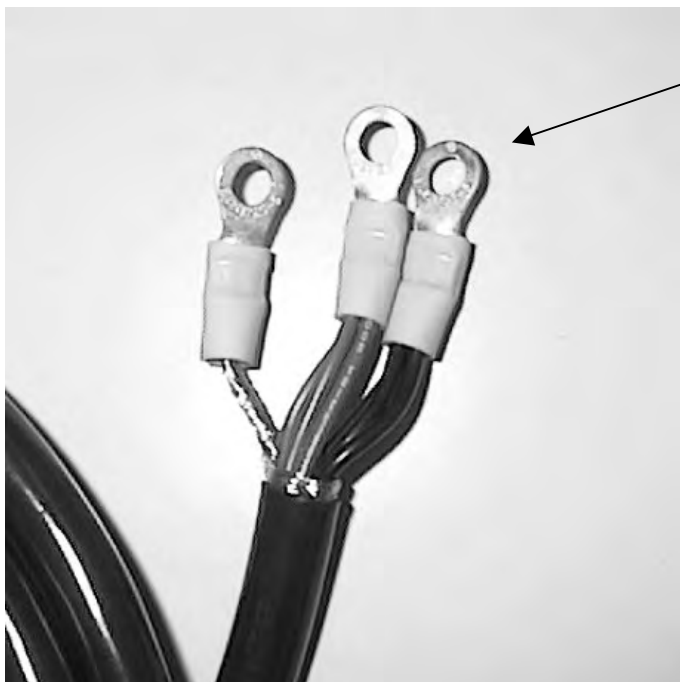

Cable process method

1. Crimp three black cables together.
2. Crimp three red cables together in the same way.
3. Crimp the shielding cable.
4. Install the red cables on the + side of the ship's power supply, the black cables on the - side of the ship's power supply, and the shielding cable in the hull's earth.

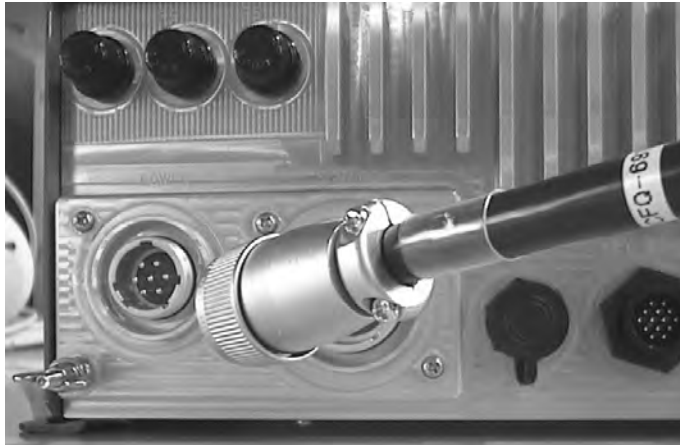

Inset cable CFQ-6911-5 into processing unit J1.

Caution

- Incorrect connection between the ship's power supply or the rectifier and the power cable may cause an equipment failure.

Selecting a cable when a long power cable is required

- The input voltage to an indicator is determined by subtracting the voltage drop up to the power cable from the ship's power supply voltage. Therefore, if the power cable is too thin or too long, the voltage drops substantially, preventing the radar from functioning at its full capacity. Use the following guideline for selecting a power cable.

- Take the voltage fluctuation rate into consideration when determining a voltage (V_s) value of the ship's power supply.
- Use the following formula for calculating a voltage drop (V).

$$V=2LRKI$$

L : Cable length

R : Direct current resistance at 20°C (Ω/m)

K : Conductor resistance temperature counting (=1.22)

I : Maximum peak current (A)

- Various cable direct current resistances (R) and allowable current (I_{max})

Cable type	R (20°C)	I_{max} (45°C continuously)
CVVS2 x 1.25	16.7 Ω/km	13A
CVVS2 x 2.0	9.42 Ω/km	19A
CVVS2 x 3.5	5.30 Ω/km	26a

Provide a sufficient extra current value to I_{max} when selecting cables.

9.3.8 Attaching a cable between a processing unit and a scanner unit (CFQ-6912-20/30)

- (a) Use this cable for connecting a processing unit and a scanner unit.
- (b) Use a cable with the following connector for this radar equipment.

Cable length	JRC code	Remarks
20m	CFQ-6912-20	Standard
30m	CFQ-6912-30	Option



Cable CFQ-6912-20/30
Connector on both sides

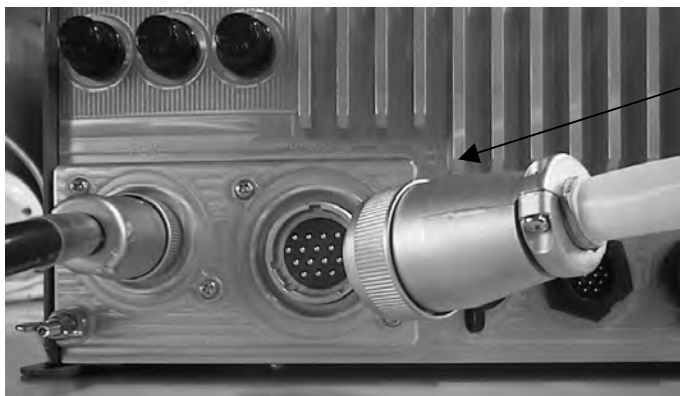

Insert cable CFQ-6912-20/30
in processing unit J2

After inserting the cable, push the cable to the end.

Connection table of cable CFQ-6912-20/30

Pin number	Color	Wire material	Signal name
1	Blue thick, gray thick	AWG16	2A
2	Purple thick, brown thick	AWG16	2A
3	White thick, orange thick	AWG16	1A
4	Red thick, green thick	AWG16	1A
5	Black thick, blue thick	AWG16	2A
6	Black	AWG22	GND
7	Drain wire (coaxial) (drain wire: Shielding, braided shielding)	AWG24	VDE
8	–	–	+12V
9	Yellow thick, pink thick	AWG16	1A
10	Coaxial cable core	AWG24	VD
11	Yellow	AWG24 twisted pair	COM+
12	Green	AWG24	BZ
13	White	AWG24 twisted pair	COM–
14	Drain wire (shielding) (drain wire: coaxial, braided shielding)	AWG24	TIE
15	Shielding wire core	AWG24	TI
16	Orange medium	AWG22	BP
Cover	Braided shielding (drain wire, coaxial, drain wire shielding)		

* Cable shape: 14mm ± 0.5mm

Caution

- A cable is not connected to pin number 8, however, +12V is output to the processing unit side. This voltage (+12V) is used when an external simulator is connected.

The explanation up to this section covers the method in standard configuration. The next section describes cable attaching methods when optional equipment is connected.

9.3.9 Connecting a GPS receiver and NMEA equipment

1. Connecting GPS receiver of JRC

A cable of a GPS receiver such as GPS100/DGPS212 can be connected by directly inserting the cable to the J3 connector.

GPS100 manufactured by JRC



Insert a cable in J3 from GPS.

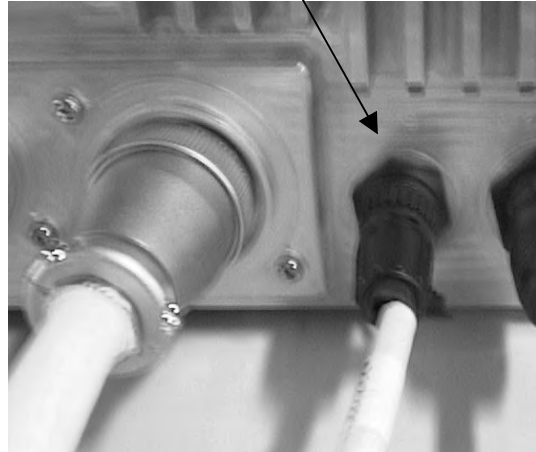

2. Connecting another manufacturer's GPS receiver or NMEA data output equipment

When connecting NMEA data from the NMEA data output equipment of JRC other than those indicated above or other manufacturer's GPS, use 6-pin connector P3 for J3 (LTWD06BFFA-L180).

Connect signal output to pin 4 from the NEMA equipment and signal return from the NEMA equipment to pin 2.

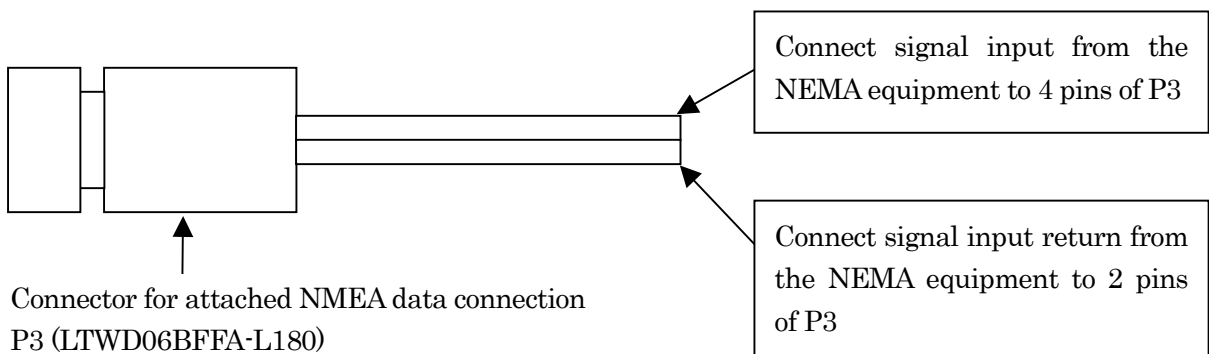

Method of assembling and connecting P3 (LTWD06BFFA-L180) and P5 (LTWD08BFFA-L180) that are attached

THE INSTRUCTION FOR FIELD INSTALLATION CONNECTOR

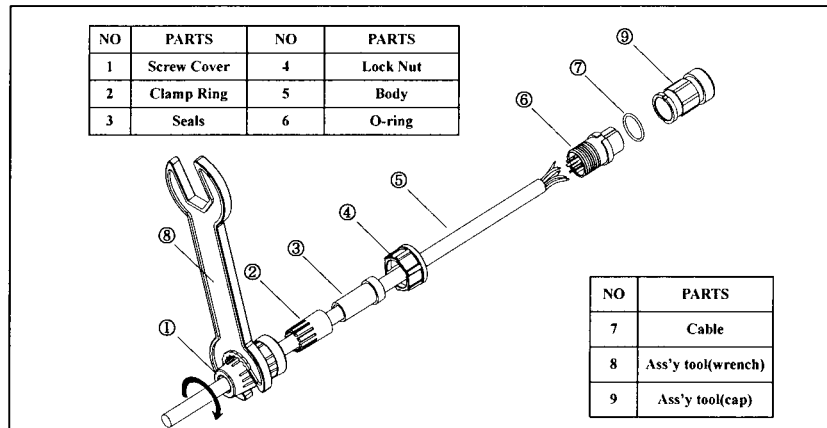

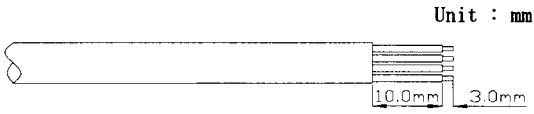
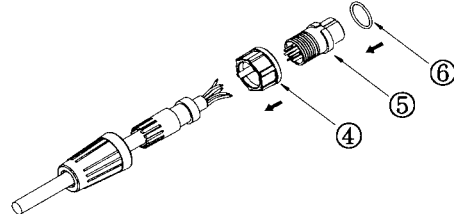
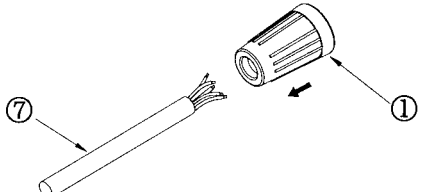
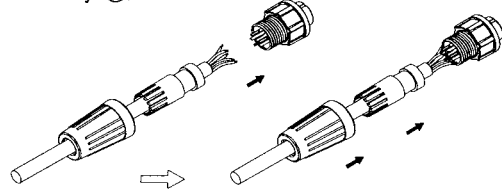
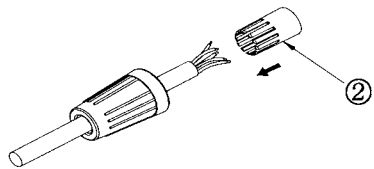
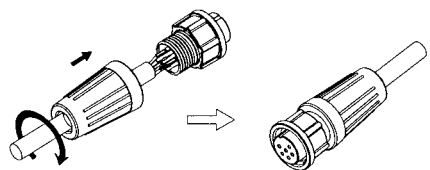
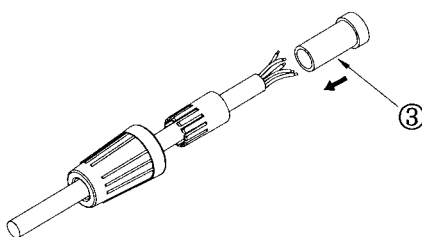
<p>Step 1: Strip cable sheath & insulation.</p>  <p style="text-align: right;">Unit : mm</p>	<p>Step 5: Insert lock nut ④ into cable, and then insert O-ring ⑥ into connector body ⑤.</p> 
<p>Step 2: Insert screw cover ① into cable.</p> 	<p>Step 6: Solder conductors to allocated contacts, then screw or install every part into connector body ⑤.</p> 
<p>Step 3: Insert clamp ring ② into cable.</p> 	<p>Step 7: Tighten screw cover with hand tool (Optional) or your hand while holding Ass'y tool (Optional)</p> 
<p>Step 4: Insert seal ③ into cable.</p> 	<p>Note: 1. Ass'y tool (cap) help to ensure good locking of screw cover into the connector body. 2. Ass'y Hand Tools (cap & wrench) are sold separately.</p>

3. NMEA0183 standard input/output sentences

●Input sentences

NORMAL INPUT	
\$xxGGA	Global Positioning System Fix Data
\$xxGLL	Geographic Position - Latitude/Longitude
\$xxVTG	Course Over Ground and Ground Speed
\$xxRMC	Recommended Minimum Specific GNSS Data
\$xxBWC	Bearing and Distance to Waypoint
\$xxRMB	Recommended Minimum Navigation Information
HIGH RATE INPIUT (Use only heading information)	
\$xxHDG	Heading, Deviation and Variation
\$xxHDM	Heading - Magnetic
\$xxHDT	Heading - True
\$xxVHW	Water Speed and Heading

●Output sentences

\$GPGGA	Global Positioning System Fix Data Necessary to connect the GPS112 or DGPS212
\$GPGLL	Geographic Position - Latitude/Longitude Necessary to connect the GPS112 or DGPS212
\$GPRMC	Recommended Minimum Specific GNSS Data Necessary to connect the GPS112 or DGPS212
\$GPVTG	Course Over Ground and Ground Speed Necessary to connect the GPS112 or DGPS212
\$RAOSD	Own Ship Data
\$RARSD	Radar System Data
\$RATTM	Tracked Target Messege

9.3.10 Connecting a GPS compass (JLR-10)

A MARPA unit, which is an optional unit, can be used by connecting GPS compass JLR-10 of JRC.

1. Using a dedicated cable

JLR-10 can be connected easily by using the CFQ-6934 dedicated cable of JRC. This cable enables not only receiving of azimuth information from JLR-10 but also receiving of longitude and latitude information as NMEA data.



Photograph 1
JLR-10/NSK unit dedicated connection cable : CFQ-6934

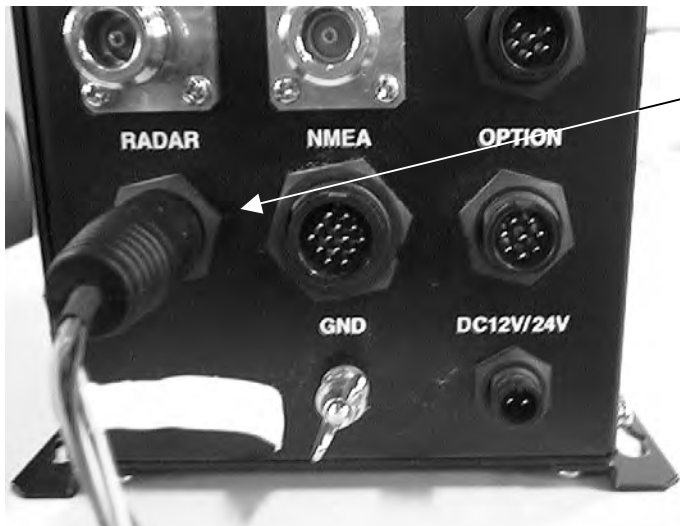

Photograph 2
Insert the 8-pin connector of CFQ-6934 with COMPAS (RADAR) label attached to the "RADAR" connector of JLR-10.

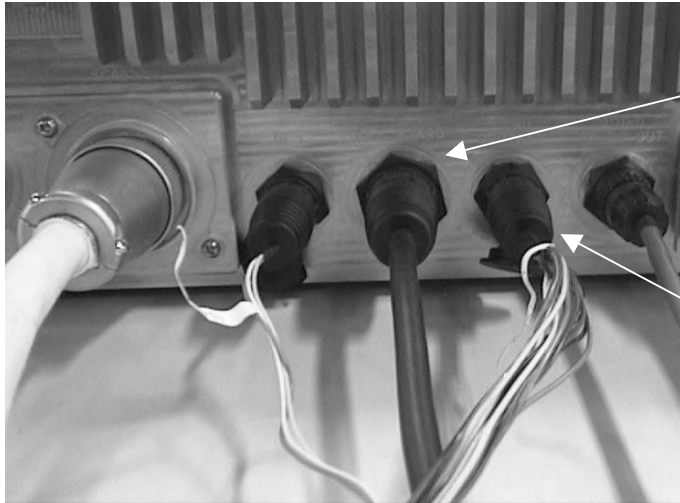

Photograph 3
 Insert the 6-pin connector of CFQ-6934 with GPS (IND) label attached to the connector of processing unit J3.

Insert the 9-pin connector of CFQ-6934 with NSK(IND) label attached to the connector of processing unit J5.

To input NMEA data such as position information from the GPS equipment of JRC or a different manufacturer by acquiring azimuth data from JLR-10, connect a cable from GPS equipment using the connection method that is described in 9.3.9, "Connecting a GPS receiver and NMEA equipment" or using a reserved cable, P3. Do not use the cable from JLR-10, which is inserted in GPS(J3) input, as shown in Photograph 3.

2. When not using a dedicated cable

To connect azimuth information data from a GPS compass, use J5 8-pin connector P5 (LTWD09BFFA-L180) that is included in the main unit package. See below for the connection method.

Signal name	GPS compass connector side	Connector of the equipment
Compass data input+	NC	J5-1
Compass data input-	NC	J5-2
Compass data output+	RADAR-4	J5-3
Compass data output-	RADAR-3	J5-4
GND	RADAR-5	J5-5

The above information is related to the connection of azimuth data for JLR-10 only. For position information, use the method that is described in 9.3.9, "Connecting a GPS receiver and NMEA equipment".

9.3.11 Connecting an electromagnetic compass

Caution

- **Make correctly connection between the output of ship's power and rectifier unit, and power cable.
If neither connection nor voltage is right, it may cause an equipment failure.**

Azimuth information can be input to a radar indicator unit if the electromagnetic compass is equipped with a NMEA0183 output pin. (An electromagnetic compass without NMEA0183 output pin cannot be connected.)

To connect azimuth information data from an electromagnetic compass, use 8-pin connector P5 for J5 (LTWD09BFFA-L180).

For the connection, connect NEMA0183+ from the electromagnetic compass to pin 3 and NEMA0183- from the electromagnetic compass to pin 4.

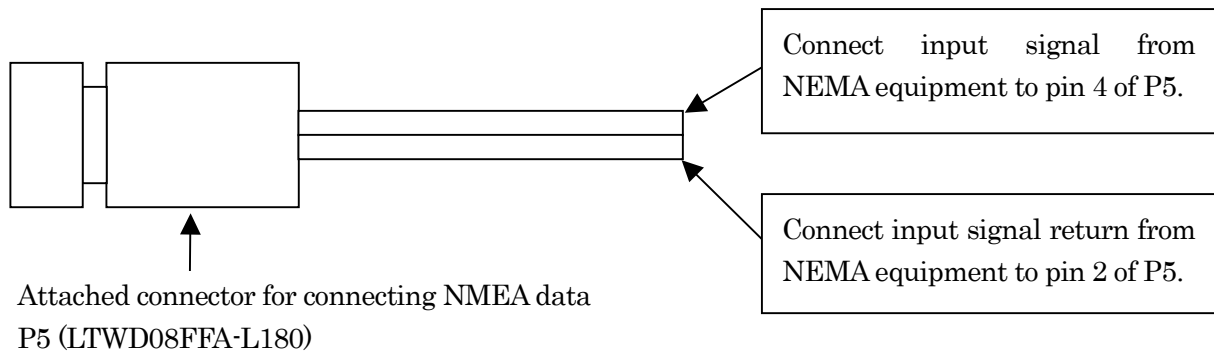

Note:

The data that can be input from a magnetic compass is NMEA-0183 (HDT/HDM/HDG format).

Caution

- **For data input from a magnetic compass, operation is not enabled even if optional MARPA is connected.
The data input from GPS compass or gyro is required.**

9.3.12 Connecting gyro

By purchasing an optional item, NSK Unit NCT-4106, gyro and electromagnetic log can be connected.

For connecting, use the CFQ-6934 dedicated cable of JRC that is enclosed by the NCT-4106.

NCT-4106 can be connected easily with the processing unit by using this cable.

And the NCT-4106 is built in the interface circuit for high capacity external buzzer contact output (dry contact output), a big buzzer can be directly driven.



Photograph 1

Insert the 8-pin connector (IND NSK) of CFQ-6934 (JLR-10/NSK unit dedicated connection cable) to the connector of processing unit J5.



Photograph 2

Insert the 8-pin connector (NSK) of CFQ-6934 (JLR-10/NSK unit dedicated connection cable) to the connector of NCT 4106.

9.3.13 Connecting a PC plotter and NMEA equipment

This equipment can output NEMA0183 data to a PC plotter and NMEA equipment. It is possible to select RS232C output and NMEA output (RS422 level) by setting a jumper pin.

1. Outputting NMEA0183 data to a PC plotter (RS232C output)

Set JP1 of the CBD-1638 power terminal block to a jumper between 1 and 2 (initial position). Connect a commercial RS232C cross cable (9-pin DSUB female) to this equipment J8 and connect the other side to the COM port of the personal computer.

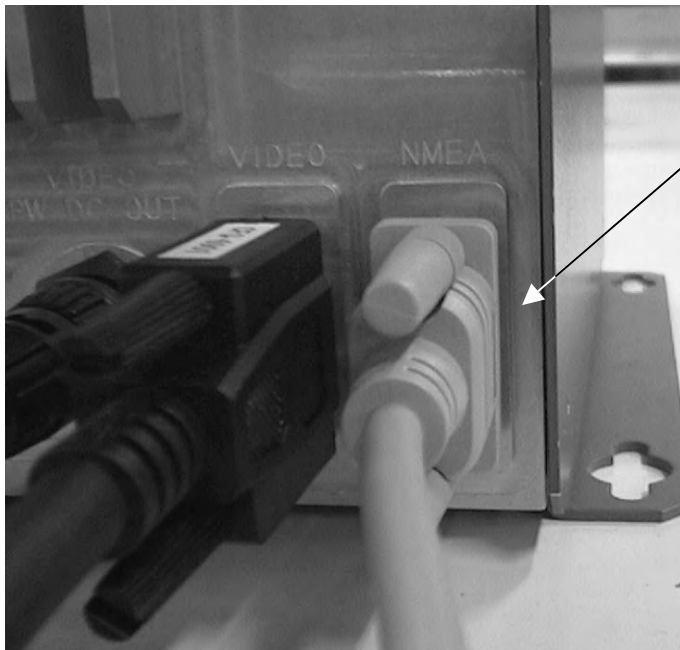

Connect a commercial 9-pin RS232C cross cable (9-pin DSUB female) to this equipment J8 and connect the other side to the COM port of the personal computer.

2. Outputting NMEA0183 data to NMEA equipment (RS422 output)

Set JP1 of the CBD-1638 power terminal block to a jumper between 2 and 3. Prepare a 9-pin DSUB female connector, connect output from pin 3 to NMEA+signal input of NMEA equipment and output from pin 5 to NMEA-signal input of NMEA equipment.

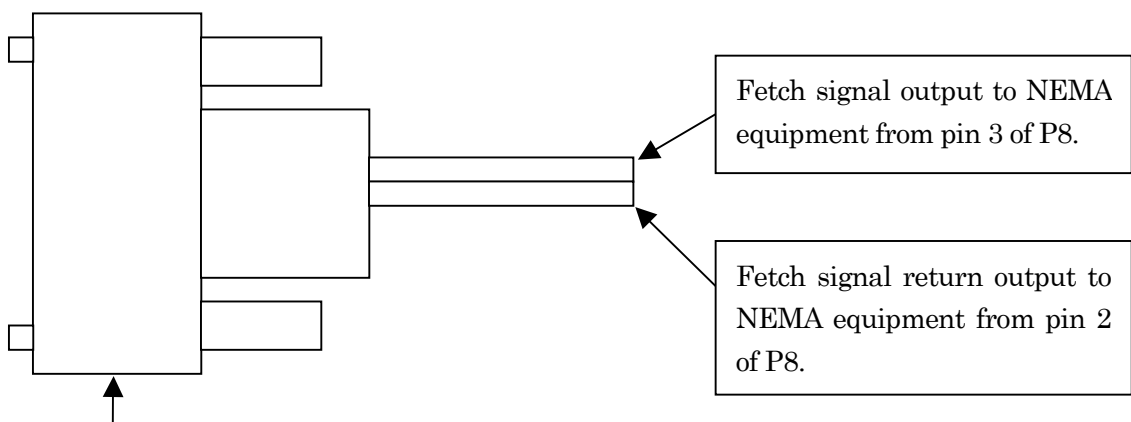

P8: Use a commercial RS232C cross cable by shortening.

3. Switching RS232C/RS422 signal output

Switching signal output from RS232C to RS422 alternately, switch jumper JP1 of power terminal block CBD-1638.

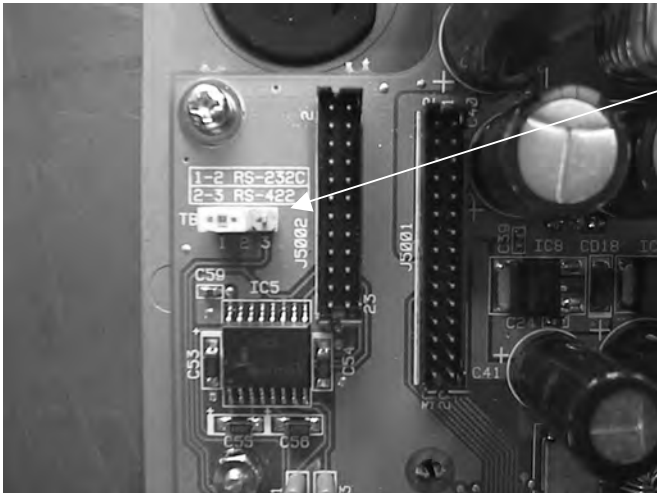

RS232C signal output
Jumper set between 1 and 2 of TB1 as shown in the photograph.

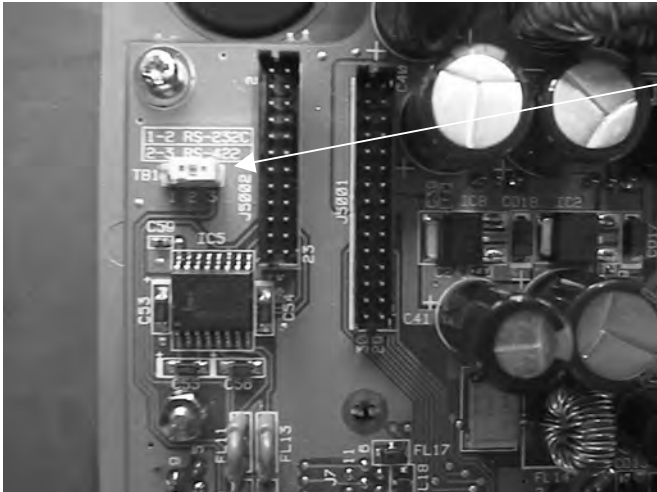

RS422 signal output
Jumper set between 2 and 3 of TB1 as shown in the photograph.

The TB1 jumper is set between 1 and 2 (RS232C) at factory delivery.

9.3.14 Connecting external buzzers

This equipment is equipped with dry contact output for external buzzers. Dry contact is output from a jumper set between pins 6 and 7 from the 8-pin connector of J5. The contact of the output is a capacity up to 1A/30V. If a greater current/voltage is applied, install equipment of adequate contact capacity such as relay in the external section.

If the current/voltage exceeds the contact capacity, the contact of this equipment becomes fused and the external buzzer keeps ringing, causing an extremely dangerous situation.

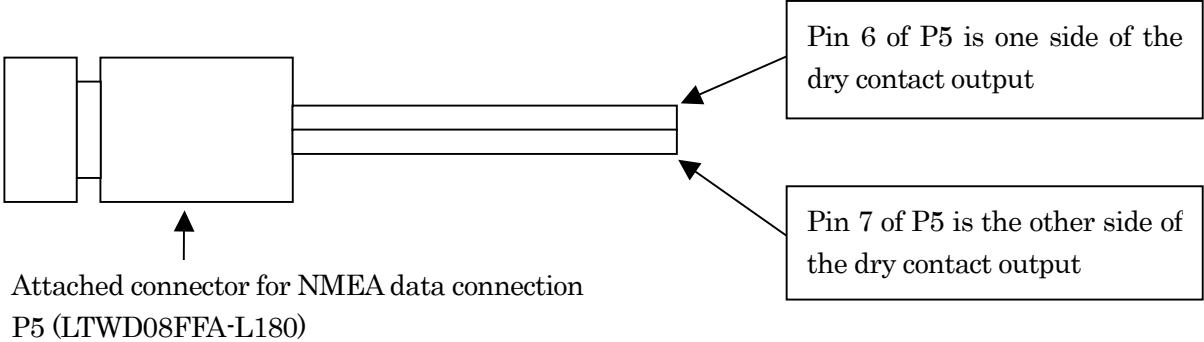

9.4 Changing Ship's Power

⚠ CAUTION



Use correct fuse ratings.
The use of incorrect ratings may cause an equipment failure.

- **Modify the ratings as follows according to the ship's power.**
(At product delivery, a fuse of 24V is provided.)

1. Display

Three types of fuses, F1, F2, and F3, are available.

- F1 : Fuse for the processing unit (10A)
- F2 : Fuse for scanner unit transmitter-receiver (or less)
- F3 : Fuse for scanner unit motor (or less)

A fuse for a processing unit (F1) is 10A regardless of the input voltage and scanner unit output. A fuse for a modulator (F2) and a fuse for a scanner unit motor (F3) change according to the input voltage as shown in the table below.

When the product is purchased, the 6.3A timelag fuse is inserted in the F2 fuse as the fuse for 12V, and the 5A timelag fuse is inserted in the F3 fuse as the fuse for 12V.

Surely exchange for the fuses suitable for the scanner unit and ship's power by using the table below.

For NKE-2042 (4kw radome type scanner unit), fuse insertion is not necessary since F3 (fuse for motor) is not available.

List of fuses

Scanner unit model	Input power voltage	F2		F3	
		Rating	JRC code	Rating	JRC code
NKE-2042 (4kw)	DC12V	6.3A time-lag	5ZFAD00543	—	—
	DC24V/32V	3.15A time-lag	5ZFAD00359	—	—
NKE-2062 (6kw)	DC12V	6.3A time-lag	5ZFAD00543	5A time-lag	5ZFAD00393
	DC24V/32V	3.15A time-lag	5ZFAD00359	5A time-lag	5ZFAD00393

2. Scanner unit

No changes are made for a scanner unit.

9.5 Checking and Adjustment After Installation

9.5.1 Checking after installation

- (a) After completion of installation, it is necessary to check if all the operations have been carried out according to the instruction. In particular, check if the cables are connected correctly, each unit is installed properly, there is no water leakage from the scanner unit, and cable shielding braiding is installed correctly.

9.5.2 Checking operation

- (a) After checking installation, confirm that the ship's voltage is within the permissible range before checking radar operation.
- (b) After examining the contents of Chapter 3, "Operation Procedures" and confirming that there is no abnormality as a result of radar operation, check that all the keyboard units function normally by actually operating them.
- (c) When re-adjustment is necessary even if the result of operation checking indicates normal, make adjustments as instructed by studying 9.6, "Adjustment".

9.5.3 Various adjustments

- (a) It is absolutely necessary to adjust the azimuth of the radar.
- (b) When the knob is set near the center at tuning or the radar cannot be tuned, make rough tuning adjustments using "Tuning preset" in the initialization menu.
- (c) When the distance on the radar PPI screen and the actual distance do not match, adjust the distance using "0 mile adjustment" in the menu.
- (d) The alarm volume can be adjusted using "Buzzer volume" in the menu.
- (e) STC can be adjusted using "Sea clutter preset" menu.

9.5.4 Rectifier

● A rectifier can be used for both of the ship's voltage types, AC100/110/115V and 200/220/230V, however, the input pin connection modes must be changed as shown in the diagram below.

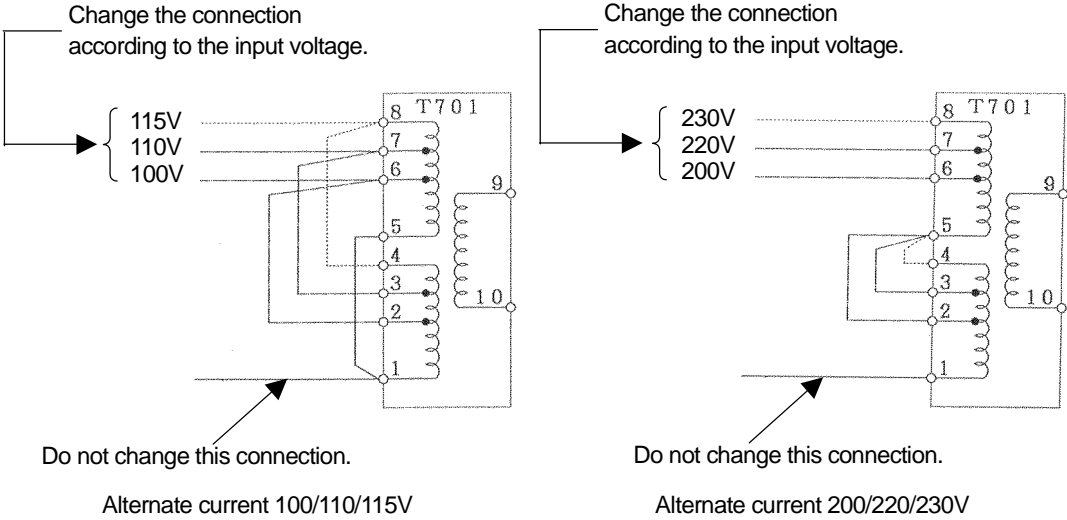

NBA-797 input pin connection change

9.6 Adjustment

9.6.1 General adjustment



Adjustment after component replacement

This section describes the adjustment required as a result of replacement of the main components.

- (a) Replacement of magnetron V101 → Tuning preset
- (b) Replacement of front end E101 → Tuning preset

9.6.2 Adjusting a scanner unit

Some scanner unit adjustments are necessary, however, no re-adjustments are necessary since the scanner unit is thoroughly adjusted at the factory. However, if adjustments become necessary as a result of the operation checking at inspection or fault repair, make the following adjustments.

 DANGER	
	<div style="border: 1px solid black; display: inline-block; padding: 2px;">High Voltage</div> <p>Since some sections of the modulator (CME-322 or QME-323) generate a high voltage of about 4000V, no one except service engineers are allowed to touch inside of the modulator. The high voltage may cause death or a serious injury of any person by electric shock.</p>

1. Adjusting AVR output voltage of a modulator

- (a) When the radar is in a transmission mode, set the distance range to 12 nautical miles, connect a voltmeter between J201-13PIN and GND of modulator CME-322 or CME-323, and adjust the voltage to +8(V) at RV2.

2. Adjusting a tuning indication level of a receiver

- (a) Set the tuning mode to manual when it is set to automatic.
- (b) Carry out tuning by setting the distance range to 12 nautical miles or more.

9.6.3 Adjusting an indicator unit

Some adjustments are necessary for the indicator unit, however, no re-adjustments are necessary since the indicator unit is thoroughly adjusted at the factory. However, if adjustments become necessary as a result of operation checking at inspection or fault repair, make the following adjustments.

Adjusting AVR output

- (a) Connect a calibrated voltmeter (digital display is recommended to eliminate reading error) between TP15 +13V and TP16 GND of power terminal block CBD-1638 and adjust the output to $+13V \pm 0.1V$.

Caution

- Make sure that the scanner unit is connected before adjustment.

9.7 Initialization

This section describes how to initialize radar equipment. Initialization of radar equipment is necessary when using it for the first time.

Initialization involves the following tasks.

- 9.7.1 Adjusting a receiver [+RANGE-] [TX/PRF] [AUTO-TUNE] [MENU]
 1. Tuning preset
 2. Center frequency adjustment
 3. Tuning indicator level adjustment
- 9.7.2 Noise level adjustment [MENU]
- 9.7.3 Azimuth adjustment [TM/RM] [AZI MODE] [MENU]
- 9.7.4 0 mile adjustment [TM/RM] [AZI MODE] [MENU]
- 9.7.5 Setting a scanner unit height [MENU]
- 9.7.6 Setting a gyro value [MENU] [AZI MODE]

Caution

- **Initialize radar equipment before using it for the first time.**
Without initialization, radar equipment can neither indicate targets nor measure distances and azimuths.

Caution

- **Do not turn off the power until the following adjustments are completed.**
Otherwise, an error occurs in the memory of the setting values that were adjusted internally and, in the worst case, the equipment may not function.

- **The initialization menu "Setting at installation" can be displayed by pressing the [MENU] key in long mode.**
Text "Initialization menu described above" is displayed in the description provided below. This setting indicates the menu indication method.

9.7.1 Adjusting a receiver [+RANGE-] [TX/PRF] [AUTO-TUNE] [MENU]

1. Tuning preset



On this menu, make a rough tuning adjustment. When this menu is displayed, the automatic tuning setting state is temporarily changed to manual tuning setting during adjustment. At completion of adjustment, the mode is reset to automatic tuning setting.

Use the following procedure to perform tuning preset.

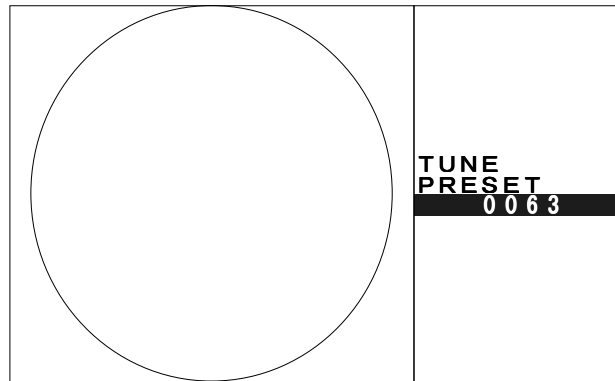
- Press the [+RANGE-] key and set the range to 24NM.
- Press the [TX/PRF] key and send signals for 10 minutes or more.
- Set the [AUTO-TUNE] knob to a 12 o'clock position.
- Display the **INSTALLATION** menu by pressing the [MENU] key in long mode, select **RADAR**, **RADAR ADJUST**, and **TUNE PRESET**, and press [JOG DIAL] or [ACQ/ENT].
- When the following menu is displayed, press [JOG DIAL] to maximize the tuning oscillation, and end the operation by pressing [JOG DIAL] or [ACQ/ENT].



2. Center frequency adjustment

 WARNING	
	<p>This adjustment is a function of adjusting tune indication and peak of echo, it is already made at the factory. The default value is 64. The settings must not be changed on the spot. When the tune indication and peak of echo shift, if the settings are carefully adjusted, you can not get the tuning. The gain falls, a collision etc. may occur.</p>

Adjust the frequency so that the image size becomes the maximum when oscillation of the tuning indicator reaches the maximum.

Use the following procedure to set a central frequency.

- Carry out steps from (a) to (c) of "1. Tuning preset".

- (b) Display the **INSTALLATION** menu by pressing the **[MENU]** key in long mode, select **RADAR**, **RADAR ADJUST**, and **CENTER FRQ**, and press **[JOG DIAL]** or **[ACQ/ENT]**.
- (c) Adjust the frequency by changing the value by turning **[JOG DIAL]** to the left or right, and end the operation by pressing **[JOG DIAL]** or **[ACQ/ENT]**.

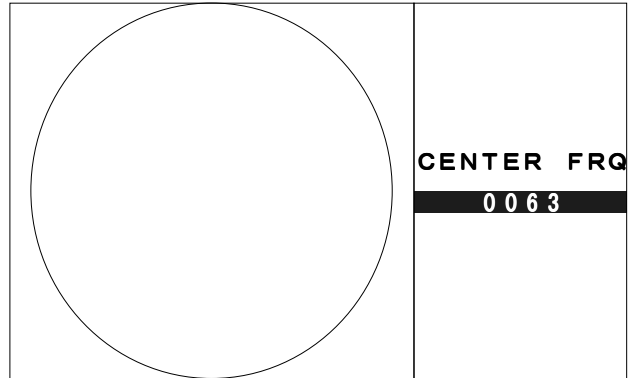

3. Tuning indicator level adjustment

Set the scale when the tuning indicator bar has reached the maximum level.

Use the following procedure to adjust a tuning indicator level.

- (a) Carry out steps from (a) to (c) of "1. Tuning preset".
- (b) Display the **INSTALLATION** menu by pressing the **[MENU]** key in long mode, select **RADAR**, **RADAR ADJUST**, and **TUNE INDICATOR**, and press **[JOG DIAL]** or **[ACQ/ENT]**.
- (c) Adjust the indicator level by changing the value by turning **[JOG DIAL]** to the left or right until the tuning indicator indicates 70% to 80% of the tuning indicator area, and end the operation by pressing **[JOG DIAL]** or **[ACQ/ENT]**.

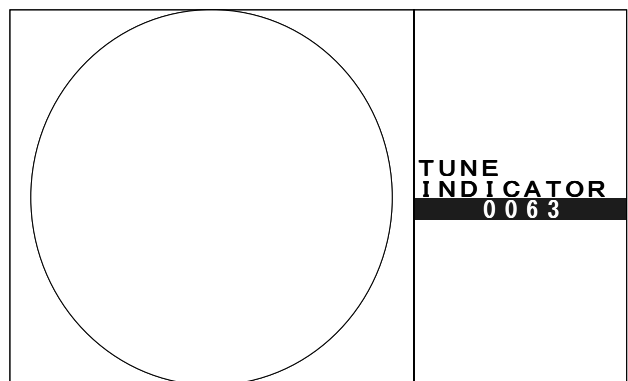

9.7.2 Noise level adjustment [MENU]

Adjust the base level of the echo that is displayed on the PPI screen.

Caution

- Since this adjustment is made at the factory before delivery, basically, the settings must not be changed.
Unnecessary adjustments cause degradation of sensitivity, causing image display abnormality.

Use the following procedure to adjust a nozzle level.

- Display the **INSTALLATION** menu by pressing the **[MENU]** key in long mode, select **RADAR**, **RADAR ADJUST2**, and **NOISE LEVEL**, and press **[JOG DIAL]** or **[ACQ/ENT]**.
- Adjust the noise level that is displayed on the screen by turning **[JOG DIAL]** to the left or right, and end the operation by pressing **[JOG DIAL]** or **[ACQ/ENT]**.

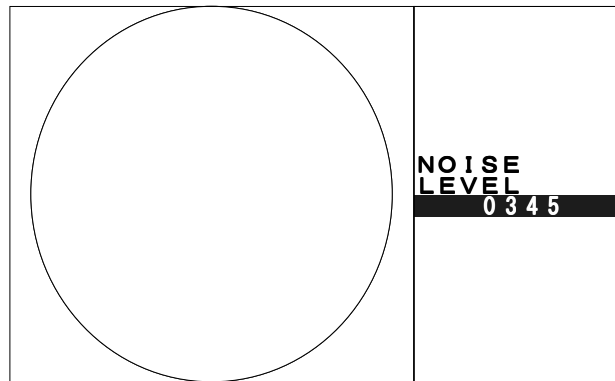

9.7.3 Azimuth adjustment [TM/RM] [AZI MODE] [MENU]

This operation is to adjust the azimuth on the PPI screen.

Use the following procedure to adjust the azimuth.

- Select the RM mode by pressing the **[TM/RM]** key.
When the mode is already set to "RM", this operation is not necessary.
- Select the H-UP mode by pressing the **[AZI MODE]** key.
When the mode is already set to "H-UP", this operation is not necessary.
- Display the **INSTALLATION** menu by pressing the **[MENU]** key in long mode, select **RADAR**, **RADAR ADJUST**, and **BEARING**, and press **[JOG DIAL]** or **[ACQ/ENT]**.
- When a line for setting an azimuth is displayed, set the azimuth to the established target on the screen by turning **[JOG DIAL]**, and press **[JOG DIAL]** or **[ACQ/ENT]**.
- Move the established target to the position to be displayed on the screen by turning **[JOG DIAL]**, and end the operation by pressing **[JOG DIAL]** or **[ACQ/ENT]**.

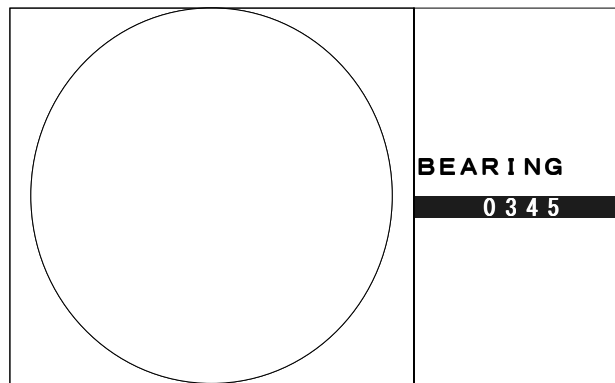

9.7.4 0 mile adjustment [TM/RM] [AZI MODE] [MENU]

This operation is to adjust the distance calibration on the PPI screen.

Use the following procedure for 0 mile adjustment.

- (a) Select the RM mode by pressing the [TM/RM] key.
When the mode is already set to "RM", this operation is not necessary.
- (b) Select the H-UP mode by pressing the [AZI MODE] key.
When the mode is already set to "H-UP", this operation is not necessary.
- (c) Set the range to 0.125 miles by pressing the [+RANGE-] key.
- (d) Display the INSTALLATION menu by pressing the [MENU] key in long mode, select RADAR, RADAR ADJUST, and DISPLAY TIMING, and press [JOG DIAL] or [ACQ/ENT].
- (e) Set the target to a required position on the screen by turning [JOG DIAL] and end the operation by pressing [JOG DIAL] or [ACQ/ENT].

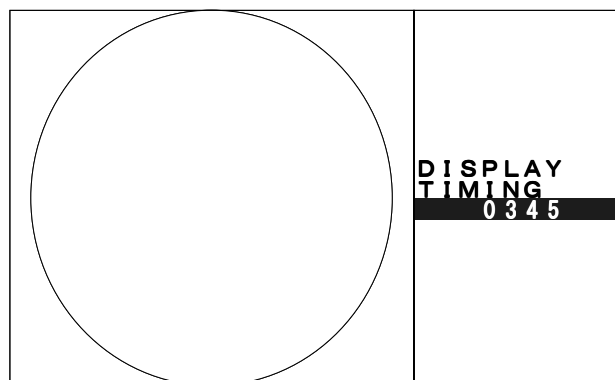

9.7.5 Setting a scanner unit height [MENU]

Set a height from a surface of the sea to the scanner unit of the radar.

By changing this setting value, the effect of the STC function (sea clutter elimination function) for distances can be changed.

This function is also useful for changing the effect of the [AUTO-SEA] knob.

Use the following procedure to set a scanner unit height.

- (a) Display the INSTALLATION menu by pressing the [MENU] key in long mode, select RADAR, RADAR ADJUST2, and ANTTENA HEIGHT, and press [JOG DIAL] or [ACQ/ENT].

- (b) When the following menu is displayed, select a required setting value from **5m**, **5-10m**, **10-m** by turning **[JOG DIAL]** and end the operation by pressing **[ACQ/ENT]**.

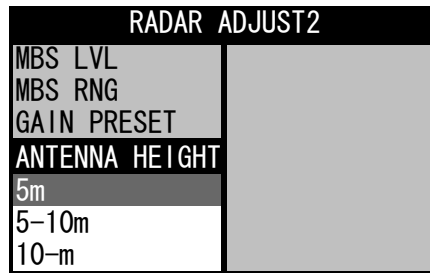

9.7.6 Setting a gyro value **[MENU]** **[AZI MODE]**

After connecting an optional NSK unit, set a master gyro value in the NSK unit.

⚠ CAUTION

The GPS compass JLR-10 of JRC always can output absolute azimuth without gyro setting.
Therefore, do not set a gyro value when connecting JLR-10.

Use the following procedure to set a gyro value.

- (a) Display the **INSTALLATION** menu by pressing the **[MENU]** key in long mode, select **GYRO SETTING**, and press **[JOG DIAL]** or **[ACQ/ENT]**.
- (b) After setting the gyro value that was read from the master gyro by turning **[JOG DIAL]**, end the operation by pressing **[JOG DIAL]** or **[ACQ/ENT]**.

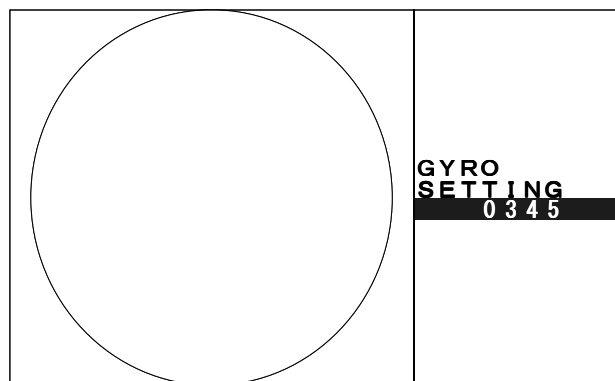

- (c) For operation (a), the menu can be opened directly from **[AZI MODE]**. When the **[AZI MODE]** key is pressed, the initial menu is displayed. Subsequent operation is the same as for (b).

9.8 Various Initial Settings

This section describes the various settings required to facilitate the use of radar such as setting of radar signal processing and setting at connection of various types of navigation equipment.

9.8.1 Sensitivity preset [AUTO-SEA] [AUTO-RAIN] [GAIN/PL] [MENU]

Set the maximum level indicated when the "Sensitivity" knob is used.

Do not change the adjustment unnecessarily. Normally, the level must be set to 255. In this case, no adjustment is necessary.

When adjustment is necessary, carry out the procedure described in 9.7.2, "Noise level adjustment [MENU]" before making further adjustments.

Use the following procedure to carry out sensitivity preset.

- (a) Set the target expansion function to OFF.
- (b) Turn the [AUTO-SEA] knob to the minimum position (anti-clockwise for one full rotation).
- (c) Turn the [AUTO-RAIN] knob to the minimum position (anti-clockwise for one full rotation).
- (d) Turn the [GAIN/PL] knob to the maximum position (clockwise for one full rotation).
(In this state, the echo is displayed at the highest level on this PPI screen.)
- (e) Display the INSTALLATION menu by pressing the [MENU] key in long mode, select RADAR, RADAR ADJUST2, and GAIN PRESET, and press [JOG DIAL] or [ACQ/ENT].
- (f) Adjust the sensitivity level by turning [JOG DIAL] and end the operation by pressing [JOG DIAL] or [ACQ/ENT].

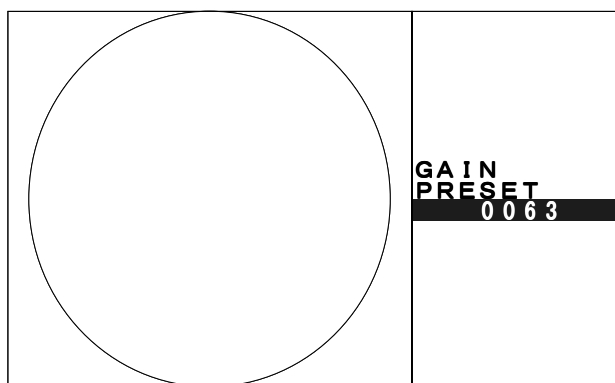

9.8.2 Sea clutter preset [+RANGE-] [AUTO-TUNE] [AUTO-SEA] [AUTO-RAIN] [GAIN/PL] [MENU]

Set the maximum control level that is indicated by turning the [AUTO-SEA] knob.

Do not change this setting unnecessarily.

Use the following procedure for executing sea clutter preset.

- (a) Set range to 6NM by using the [+RANGE-] key.
- (b) Adjust the tuning using the [AUTO-TUNE] knob.
- (c) Set the target expansion function to OFF.
- (d) Turn the [AUTO-SEA] knob to the maximum position (clockwise for one full rotation).
- (e) Turn the [AUTO-RAIN] knob to the minimum position (anti-clockwise for one full rotation).
- (f) Turn the [GAIN/PL] knob to the maximum position (clockwise for one full rotation).

(In this state, the echo is displayed at the highest level on this PPI screen.)

- (g) Display the **INSTALLATION** menu by pressing the **[MENU]** key in long mode, select **RADAR**, **RADAR ADJUST2**, and **STC PRESET**, and press **[JOG DIAL]** or **[ACQ/ENT]**.
- (h) Adjust the control level to the level where noise near 6NM is slightly above by turning **[JOG DIAL]** and end the operation by pressing **[JOG DIAL]** or **[ACQ/ENT]**.

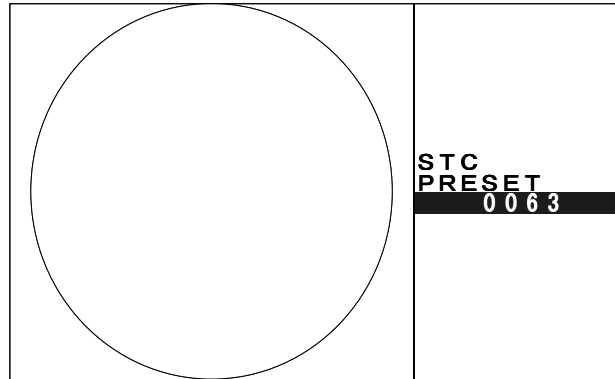

9.8.3 Control of main bang [+RANGE-] [AUTO-TUNE] [AUTO-SEA] [AUTO-RAIN] [GAIN/PL] [MENU]

This adjustment is to suppress a main bang, which is a reflection signal from a microwave circuit of a waveguide that normally appears as a circular image at the center of the radar screen.

In the optimum adjustment, a faint image of a main bang remains on the screen.

WARNING



Do not change this adjustment unnecessarily.
An incorrect adjustment may erase the closest target and a collision occurs, this may cause death or a serious injury of any person.

Use the following procedure to set a main bang suppression level and its range.

- (a) Set range to 0.125NM by using the **[+RANGE-]** key.
- (b) Adjust the tuning using the **[AUTO-TUNE]** knob.
- (c) Set the target expansion function to OFF.
- (d) Set the correlation processing function to OFF.
- (e) Turn the **[AUTO-SEA]** knob to the center position, and adjust the function strength to the extent that main bang can be indentified.
- (f) Turn the **[AUTO-RAIN]** knob to the minimum position (anti-clockwise for one full rotation).
- (g) Turn the **[GAIN/PL]** knob to the maximum position (clockwise for one full rotation).
(In this state, the echo is displayed at the highest level on this PPI screen.)
- (h) Display the **INSTALLATION** menu by pressing the **[MENU]** key in long mode, select **RADAR**, **RADAR ADJUST2**, and **MBS LVL**, and press **[JOG DIAL]** or **[ACQ/ENT]**.

- (i) Adjust the main bang suppression level by turning **[JOG DIAL]** and erase the main bang. After completion of adjustment of the suppression level, end the operation by pressing **[JOG DIAL]** or **[ACQ/ENT]**.

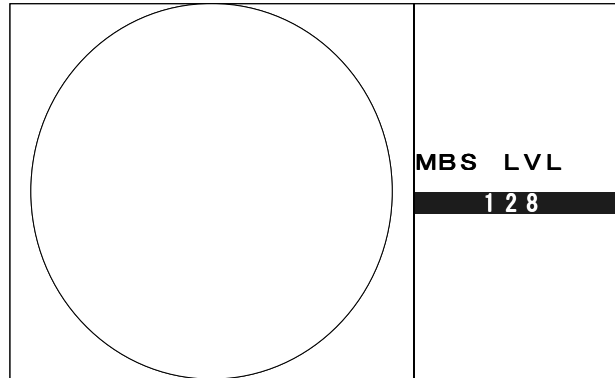

Consequently, the main bang suppression level has been adjusted.

- (j) Select **[MBS RNG]** by turning **[JOG DIAL]**, set the main bang erasing range and end the operation by pressing **[JOG DIAL]** or **[ACQ/ENT]**.
- (k) Adjust and set the main bang suppression range by turning **[JOG DIAL]** and end the operation by pressing **[JOG DIAL]** or **[ACQ/ENT]**.

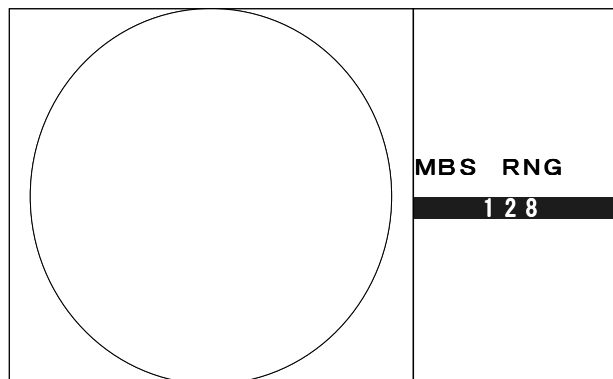

Consequently, the main bang suppression range has been adjusted.

9.8.4 Setting a close range dynamic range [MENU]

Set a range for changing a close range dynamic range. A range from 0.0 to 3.3 miles can be set.

Use the following procedure to set a close range dynamic range.

- (a) Display the **[INSTALLATION]** menu by pressing the **[MENU]** key in long mode, select **[RADAR]**, **[RADAR ADJUST2]**, and **[DR NEAR RNG.]**, and press **[JOG DIAL]** or **[ACQ/ENT]**.
- (b) Adjust the main bang suppression level by turning **[JOG DIAL]** and erase the main bang. After completion of adjustment of the suppression level, end the operation by pressing **[JOG DIAL]** or **[ACQ/ENT]**.

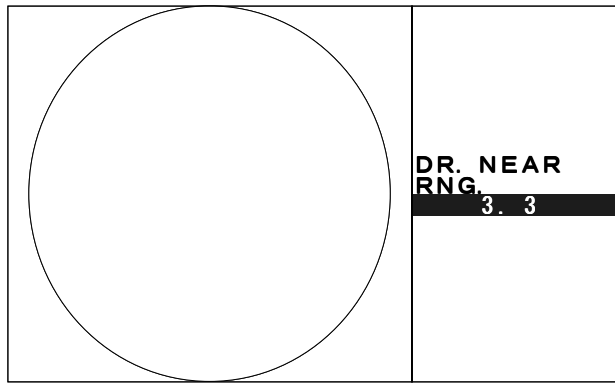

9.8.5 Setting a video gradation level [MENU]

Set a video gradation (dynamic range).

The following levels are available:

- NARROW: Although the video gradation range becomes narrow, the sensitivity increases. Suitable for long range.
- NORMAL: Normal video gradation
- WIDE: The video gradation range becomes wide, enabling checking of the targets such as sea clutter, rain, and snow more easily.

Use the following procedure to set a video gradation level.

- (a) Display the **INSTALLATION** menu by pressing the **[MENU]** key in long mode, select **RADAR**, **RADAR SETTING**, and **VIDEO LATITUDE**, and press **[JOG DIAL]** or **[ACQ/ENT]**.
- (b) When the following menu is displayed, select **NORMAL**, **NARROW**, or **WIDE** by turning **[JOG DIAL]** and end the operation by pressing **[JOG DIAL]** or **[ACQ/ENT]**.

RADAR SETTING	
VIDEO LATITUDE	NARROW
NORMAL	LEVEL 1
NARROW	OFF
WIDE	OFF
IR SHIFT	OFF
DR RANGE CONT	OFF
TGT EXP LEVEL	LEVEL 1
TGT EXP PROC	OFF
GAIN OFFSET	0

9.8.6 Setting video noise suppression display [MENU]

This function enables removal of unnecessary noise such as noise and sea clutter at display of a radar image, by setting a threshold value to suppression of display of a low gradation section (noise components). Noise display suppression increases in the sequence of OFF → LEVEL 1 → LEVEL 2.

The following options are available:

- OFF: Displays level 0 or higher of 16 levels (all the levels).
- LEVEL 1: Displays level 4 or higher of 16 levels.
- LEVEL 2: Displays level 8 or higher of 16 levels.

Use the following procedure to set a video gradation level.

- (a) Display the **INSTALLATION** menu by pressing the **[MENU]** key in long mode, select **RADAR**, **RADAR SETTING**, and **VD NOISE REJ**, and press **[JOG DIAL]** or **[ACQ/ENT]**.
- (b) When the following menu is displayed, select **OFF**, **LEVEL 1**, or **LEVEL 2** by turning **[JOG DIAL]** and end the operation by pressing **[JOG DIAL]** or **[ACQ/ENT]**.

RADAR SETTING	
VIDEO LATITUDE	NARROW
VD NOISE REJ	LEVEL1
OFF	OFF
LEVEL1	OFF
LEVEL2	OFF
DR RANGE CONT	OFF
TGT EXP LEVEL	LEVEL1
TGT EXP PROC	OFF
GAIN OFFSET	0

9.8.7 Setting a small target detection mode **[MENU]**

This function detects a distant faint target on a radar image.

To detect a distant faint target, increase a detection probability by reducing the scanner unit rotation speed and focusing radio waves of the radar to a distant faint target.

Note

Since 4kw is a radome type and does not have a motor rotation control function, this function does not operate even if it is set to ON.

Use the following procedure to set a small target detection mode.

- (a) Display the **INSTALLATION** menu by pressing the **[MENU]** key in long mode, select **RADAR**, **RADAR SETTING**, and **S-BUOY DETECT**, and press **[JOG DIAL]** or **[ACQ/ENT]**.
- (b) When the following menu is displayed, select **ON** by turning **[JOG DIAL]** and end the operation by pressing **[JOG DIAL]** or **[ACQ/ENT]**.

RADAR SETTING	
VIDEO LATITUDE	NARROW
VD NOISE REJ	LEVEL1
S-BUOY DETECT	OFF
OFF	OFF
ON	OFF
DR RANGE CONT	OFF
TGT EXP LEVEL	LEVEL1
TGT EXP PROC	OFF
GAIN OFFSET	0

9.8.8 Setting a float mode [MENU]

Use this function to change a start level of STC near your ship by adjusting the [AUTO-SEA] knob on the keyboard when buoys such as floats are to be displayed and the auto STC function is ON. In general, when buoys such as floats are to be observed by setting the auto STC/auto FTC function to ON, it is recommended to set a tolerant level for the STC near your ship.

Use the following procedure to set a video gradation level.

- Display the **INSTALLATION** menu by pressing the **[MENU]** key in long mode, select **RADAR**, **RADAR SETTING**, and **F-NET DETECT**, and press **[JOG DIAL]** or **[ACQ/ENT]**.
- When the following menu is displayed, select **ON** by turning **[JOG DIAL]** and end the operation by pressing **[JOG DIAL]** or **[ACQ/ENT]**.

RADAR SETTING	
VIDEO LATITUDE	NARROW
VD NOISE REJ	LEVEL1
S-BUOY DETECT	OFF
F-NET DETECT	OFF
OFF	OFF
ON	OFF
TGT EXP LEVEL	LEVEL1
TGT EXP PROC	OFF
GAIN OFFSET	0

9.8.9 Setting an inference suppression function level [MENU]

This function weakens the normal interference suppression function by shifting all the values of IR1, IR2, and IR3.

When radar interference suppression has started strongly, set this function to ON.

When this function is set to ON, the interference suppression performance is decreased, however, a possibility of becoming easy to detect small targets and distant faint targets come out.

Use the following procedure to set a video gradation level.

- Display the **INSTALLATION** menu by pressing the **[MENU]** key in long mode, select **RADAR**, **RADAR SETTING**, and **IR SHIFT**, and press **[JOG DIAL]** or **[ACQ/ENT]**.
- Select **ON** by turning **[JOG DIAL]** and end the operation by pressing **[JOG DIAL]** or **[ACQ/ENT]**.

RADAR SETTING	
VIDEO LATITUDE	NARROW
VD NOISE REJ	LEVEL1
S-BUOY DETECT	OFF
F-NET DETECT	OFF
IR SHIFT	OFF
OFF	OFF
ON	LEVEL1
TGT EXP PROC	OFF
GAIN OFFSET	0

9.8.10 Setting a short distance dynamic range [MENU]

Use this function to change a short distance dynamic range by using the [AUTO-SEA] knob.

Use the following procedure to set a video gradation level.

- (a) Display the **INSTALLATION** menu by pressing the **[MENU]** key in long mode, select **RADAR**, **RADAR SETTING**, and **DR RANGE CONT**, and press **[JOG DIAL]** or **[ACQ/ENT]**.
- (b) When the following menu is displayed, select **ON** by turning **[JOG DIAL]** and end the operation by pressing **[JOG DIAL]** or **[ACQ/ENT]**.

RADAR SETTING	
VIDEO LATITUDE	NARROW
VD NOISE REJ	LEVEL1
S-BUOY DETECT	OFF
F-NET DETECT	OFF
IR SHIFT	OFF
DR RANGE CONT	OFF
OFF	LEVEL1
ON	OFF
GAIN OFFSET	0

9.8.11 Setting a value of the target expansion function [MENU]

This function sets the degree of effect when the target expansion function is ON. The values that can be set are LEVEL 1, LEVEL 2, LEVEL 3, and LEVEL 4 and the target expansion distance and the expansion rate in the azimuth direction increase in that sequence.

If the level is increased too much, the distance resolution deteriorate. Therefore, set an appropriate value.

Use the following procedure to set a video gradation level.

- (a) Display the **INSTALLATION** menu by pressing the **[MENU]** key in long mode, select **RADAR**, **RADAR SETTING**, and **TGT EXP LEVEL**, and press **[JOG DIAL]** or **[ACQ/ENT]**.
- (b) When the following menu is displayed, select one of the levels from **LEVEL 1** to **LEVEL 4** by turning **[JOG DIAL]** and end the operation by pressing **[JOG DIAL]** or **[ACQ/ENT]**.

RADAR SETTING	
VIDEO LATITUDE	NARROW
VD NOISE REJ	LEVEL1
S-BUOY DETECT	OFF
F-NET DETECT	OFF
TGT EXP LEVEL	OFF
LEVEL1	OFF
LEVEL2	LEVEL1
LEVEL3	OFF
LEVEL4	0

9.8.12 Setting target expansion function control [MENU]

Use this function to set whether the target expansion function can be set to ON in the main menu.

Use the following procedure to set a video gradation level.

- (a) Display the **INSTALLATION** menu by pressing the **[MENU]** key in long mode, select **RADAR**, **RADAR SETTING**, and **TGT EXP PROC**, and press **[JOG DIAL]** or **[ACQ/ENT]**.
- (b) When the following menu is displayed, select **ON** by turning **[JOG DIAL]** and end the operation by pressing **[JOG DIAL]** or **[ACQ/ENT]**.

RADAR SETTING	
VIDEO LATITUDE	NARROW
VD NOISE REJ	LEVEL1
S-BUOY DETECT	OFF
F-NET DETECT	OFF
IR SHIFT	OFF
DR RANGE CONT	OFF
TGT EXP PROC	LEVEL1
OFF	OFF
ON	0

9.8.13 Setting a sensitivity correction value [MENU]

Use this function to increase or reduce the sensitivity temporarily by increasing or reducing the noise level value when setting function key sensitivity correction to ON for distant targets.

A sensitivity correction value can be set within the range from -32 to +32.

Use the following procedure to set a sensitivity correction value.

- (a) Display the **INSTALLATION** menu by pressing the **[MENU]** key in long mode, select **RADAR**, **RADAR SETTING**, and **GAIN OFFSET**, and press **[JOG DIAL]** or **[ACQ/ENT]**.
- (b) Select value from **-32** to **+32** by turning **[JOG DIAL]** and end the operation by pressing **[JOG DIAL]** or **[ACQ/ENT]**.

RADAR SETTING	
VIDEO LATITUDE	NARROW
VD NOISE REJ	LEVEL1
S-BUOY DETECT	OFF
F-NET DETECT	OFF
IR SHIFT	OFF
DR RANGE CONT	OFF
TGT EXP LEVEL	LEVEL1
GAIN OFFSET	OFF
0	0

9.8.14 Setting transmission power control [MENU]

This function sets transmission power.

The following options are available.

NORMAL : Normal power

HIGH POWER : Although the life span of the magnetron decreases, the sensitivity increases.

ECONOMY : Although the sensitivity decreases, the life span of the magnetron increases.

Use the following procedure to set a video gradation level.

- (a) Display the **INSTALLATION** menu by pressing the **[MENU]** key in long mode, select **RADAR**, **RADAR SETTING**, and **XMT REP. FREQ**, and press **[JOG DIAL]** or **[ACQ/ENT]**.
- (b) Select **NORMAL**, **HIGH POWER**, or **ECONOMY** by turning **[JOG DIAL]** and end the operation by pressing **[JOG DIAL]** or **[ACQ/ENT]**.

RADAR SETTING	
VIDEO LATITUDE	NARROW
VD NOISE REJ	LEVEL1
S-BUOY DETECT	OFF
F-NET DETECT	OFF
IR SHIFT	OFF
DR RANGE CONT	OFF
XMT REP. FREQ	LEVEL1
NORMAL	OFF
HIGH POWER	0
ECONOMY	NORMAL

9.8.15 Setting a scanner unit rotation speed [MENU]

This function sets a transmission rotation speed.

This radar equipment has a function that automatically sets the scanner unit rotation speed to the pre-specified speed according to the change of the range/pulse width.

The pulse width and range differ according to 6/10KW. The operation is as follows.

Use the following procedure to set a video gradation level.

- (a) Display the **INSTALLATION** menu by pressing the **[MENU]** key in long mode, select **ROT SPEED**, and press **[JOG DIAL]** or **[ACQ/ENT]**.
- (b) Select one of **HIGH**, **MIDDLE**, and **LOW** by turning **[JOG DIAL]** and end the operation by pressing **[JOG DIAL]** or **[ACQ/ENT]**.

ROT SPEED	
0.125NM	HIGH
0.25NM	HIGH
0.5NM	HIGH
0.75NM	HIGH
1.5NM-SP	HIGH
1.5NM-LP	HIGH
3NM-SP	HIGH
3NM-LP	HIGH
6NM-SP	HIGH
6NM-LP	HIGH
NEXT	

ROT SPEED	
0.125NM	HIGH
HIGH	HIGH
MIDDLE	HIGH
LOW	HIGH
1.5NM-SP	HIGH
1.5NM-LP	HIGH
3NM-SP	HIGH
3NM-LP	HIGH
6NM-SP	HIGH
6NM-LP	HIGH
NEXT	

In the menu shown above, a speed of 0.125 miles of 6KW is set. As shown in the menu on the left-hand side, each range/pulse width can be changed for each pulse width within the range.

Caution

- There is no scanner unit rotation speed function in 4KW.

9.8.16 Setting information in a GPS receiver

In this section, initial values are set in a GPS receiver (GPS receiver of JRC).

1. Setting the position of your own ship [MENU]

Transmit latitude and longitude information of the position of your own ship to a GPS receiver.

Use the following procedure to set a video gradation level to a GPS receiver.

- (a) Display the **INSTALLATION** menu by pressing the **[MENU]** key in long mode, select **GPS**, **GPS SETTING**, and **POSITION**, **[JOG DIAL]** or **[ACQ/ENT]**.
- (b) When the following menu is displayed, set the South and the North of the latitude, unit of the degree, unit of the minute, and the unit of the second sequentially. As the procedure for those settings, change the numbers by turning **[JOG DIAL]**, determine the entry of each item by pressing **[JOG DIAL]** or **[ACQ/ENT]**. When the information up to the second of the latitude is determined, the cursor moves to the longitude line. Change the settings of the East and the West of the longitude, the unit of the degree, the unit of the second in that sequence by turning **[JOG DIAL]**, determine the entry of each item by pressing **[JOG DIAL]** or **[ACQ/ENT]**, and end the operation.

GPS SETTING	
POSITION	N 36° 36.000'
N 36° 36.000'	E136° 36.000'
E136° 36.000'	10M
GEODETIC DATUM	WGS-84
FIX MODE	AUTO
HDOP LEVEL	10
AVERAGE	MANUAL 2S
EXCLUDE SAT	00 00 00
	00 00 00
MASTER RESET	
TX COMMAND	

2. Setting a height of own ship [MENU]

Send a height of your own ship to a GPS receiver.

Use the following procedure to set a video gradation level to a GPS receiver.

- (a) Display the **INSTALLATION** menu by pressing the **[MENU]** key in long mode, select **GPS**, **GPS SETTING**, and **ANTENNA HEIGHT**, and press **[JOG DIAL]** or **[ACQ/ENT]**.

- (b) When the following menu is displayed, change the numbers using **[JOG DIAL]**, and if a required value is set, end the operation by pressing **[JOG DIAL]** or **[ACQ/ENT]**.

GPS SETTING	
POSITION	N 36° 36.000' E136° 36.000'
ANTENNA HEIGHT	10M
10M	WGS-84
FIX MODE	AUTO
HDOP LEVEL	10
AVERAGE	MANUAL 2S
EXCLUDE SAT	00 00 00 00 00 00
MASTER RESET	
TX COMMAND	

3. Setting geodetic information **[MENU]**

This function sets geodetic information of the current position of own ship and sends the information to a GPS receiver.

Use the following procedure to set geodetic information to a GPS receiver.

- (a) Display the **INSTALLATION** menu by pressing the **[MENU]** key in long mode, select **GPS**, **GPS SETTING**, and **GEODETTIC DATUM**, and press **[JOG DIAL]** or **[ACQ/ENT]**.
- (b) When the following menu is displayed, set the required geodetic information by turning **[JOG DIAL]** and end the operation by pressing **[JOG DIAL]** or **[ACQ/ENT]**.

GPS SETTING	
POSITION	N 36° 36.000' E136° 36.000'
ANTENNA HEIGHT	10M
GEODETTIC DATUM	WGS-84
WGS-84	AUTO
	10
AVERAGE	MANUAL 2S
EXCLUDE SAT	00 00 00 00 00 00
MASTER RESET	
TX COMMAND	

List of geodetic information

No.	Name
0	WGS-84
1	WGS-72
2	Japan
3	North American 1927 (U.S)
4	North American 1927 (Canada & Alaska)
5	European 1950 (Europe)
6	Australian geodetic 1966 (Australia)
7	Ordance Survery of Great Britain (England)
8	NAD-83
9	— (no use)
10	— (no use)
11	ADINDAN (Etiopia & Sudan)
12	ARC 1950 (Botswana)
13	AUSTRALIAN GEODETIC 1984 (Australia)
14	BERMUDA 1957 (the Bermudas)
15	BOGOTA OBSERVATORY (Columbia)
16	CAMPO INCHAUSPE
17	CHATHAM 1971
18	CHUA ASTRO (Paraguay)
19	CORREGO ALEGRE (Brazil)
20	DJAKARTA (VATAVIA) (Sumata)
21	EUROPEAN 1979 (Europe)
22	GEODETIC DATUM 1949 (New Zealand)
23	GUAM 1963 (Guam)
24	HAYFORD 1910 (Finland)
25	HJORSEY 1955 (Ice land)
26	INDIAN (India & Nepal)
27	IRELAND
28	KERTAU 1948 (West Malaysia)
29	L.C.5 ASTRO (Cayman Black Island)
30	LIBERIA 1964 (Liberia)
31	LUZON (Philippines)
32	MERCHICH (Morocco)

No.	Name
33	MINNA (Cameroon)
34	NAHRWAN (Oman)
35	NAPARIMA, BWI (Trinidad and Tobago)
36	OLD EGYPTIAN (egypt)
37	OLD HAWAIIAN (the Hawaii Island)
38	PICO DE LAS NIEVES (the Canary Island)
39	PROVISIONAL SOUTH AMERICAN 1956 (South America)
40	PROVISIONAL SOUTH CHILEAN 1963 (Southern Chile)
41	PUETRO RICO (Puerto Rico and V irgin Island)
42	QORNOQ (South Greenland)
43	RT90 (Sweden)
44	SANTA BRAZ (Sao Maguel, Santa Maria Island)
45	SOUTH AMERICAN 1969 (South America)
46	SOUTHWEST BASE (Faial,Graciosa,Pico,Jorge and terceira Island)
47	TIMBALAI 1948 (Brunei and East Malaysia)

4. Setting a position fixing mode [MENU]

This function sets a position fixing mode of a GPS receiver and sends the information to a GPS receiver.

2D cannot obtain height information in two-dimensional position fixing.

3D cannot obtain height information in three-dimensional position fixing.

AUTO automatically selects the optimum of 2D and 3D position fixing.

Use the following procedure to set a position fixing mode to GPS receiver.

- Display the **INSTALLATION** menu by pressing the **[MENU]** key in long mode, select **GPS**, **GPS SETTING**, and **FIX MODE**, and press **[JOG DIAL]** or **[ACQ/ENT]**.
- When the following menu is displayed, select **2D**, **3D**, or **AUTO** by turning **[JOG DIAL]** and end the operation by pressing **[JOG DIAL]** or **[ACQ/ENT]**.

GPS SETTING	
POSITION	N 36° 36.000' E136° 36.000'
ANTENNA HEIGHT	10M
GEODETTIC DATUM	WGS-84
FIX MODE	AUTO
2D	10
3D	MANUAL 2S
AUTO	00 00 00 00 00 00
MASTER RESET	
TX COMMAND	

5. Setting a HDOP level [MENU]

This function sends a HDOP level of a GPS receiver to a GPS receiver.

Three HDOP levels, 4, 10, 20 are available. The lower the value, the higher is the precision. However, position fixing becomes more difficult.

Normally, customers need not set this information.

Use the following procedure to set a HDOP level to a GPS receiver.

- Display the **INSTALLATION** menu by pressing the **[MENU]** key in long mode, select **GPS**, **GPS SETTING**, and **HDOP LEVEL**, and press **[JOG DIAL]** or **[ACQ/ENT]**.
- When the following menu is displayed, select **4**, **10**, or **20** by turning **[JOG DIAL]** and end the operation by pressing **[JOG DIAL]** or **[ACQ/ENT]**.

GPS SETTING	
POSITION	N 36° 36.000' E136° 36.000'
ANTENNA HEIGHT	10M
GEODETTIC DATUM	WGS-84
FIX MODE	AUTO
HDOP LEVEL	10
4	MANUAL 2S
10	00 00 00
20	00 00 00
MASTER RESET	
TX COMMAND	

6. Setting an averaging level [MENU]

This function sends time data for averaging position information that is output from a GPS receiver to a GPS receiver. Three types of averaging levels, 2 seconds, 10 seconds, and 40 seconds, are available. A lower value represents faster data updating, however, the position information that is received is uneven.

Normally, customers need not set this information.

Use the following procedure to set a video gradation level to a GPS receiver.

- Display the **INSTALLATION** menu by pressing the **[MENU]** key in long mode, select **GPS**, **GPS SETTING**, and **AVERAGE** and press **[JOG DIAL]** or **[ACQ/ENT]**.
- When the following menu is displayed, select **40S**, **10S**, or **2S** by turning **[JOG DIAL]** and end the operation by pressing **[JOG DIAL]** or **[ACQ/ENT]**.

GPS SETTING	
POSITION	N 36° 36.000' E136° 36.000'
ANTENNA HEIGHT	10M
GEODETTIC DATUM	WGS-84
FIX MODE	AUTO
HDOP LEVEL	10
AVERAGE	MANUAL 2S
40S	00 00 00
10S	00 00 00
2S	
TX COMMAND	

7. Setting a prohibited satellite number [MENU]

This function sends a satellite that is prohibited to a GPS receiver among the GPS satellites that have been launched.

Normally, customers need not set this information.

Use the following procedure to set a prohibited satellite number.

- Display the **INSTALLATION** menu by pressing the **[MENU]** key in long mode, select **GPS**, **GPS SETTING**, **EXCLUDE SAT** and press **[JOG DIAL]** or **[ACQ/ENT]**.
- When the following menu is displayed, set a satellite number using **[JOG DIAL]**, determine the entry by pressing **[JOG DIAL]** or **[ACQ/ENT]**, repeat these steps until all the information items are entered, and end the operation by returning to the previous menu.

GPS SETTING	
POSITION	N 36° 36.000' E136° 36.000'
ANTENNA HEIGHT	10M
GEODETTIC DATUM	WGS-84
EXCLUDE SAT	AUTO
00	10
00	MANUAL 2S
00	00 00 00
00	00 00 00
00	
00	

8. GPS receiver master reset [MENU]

This function sends master reset to a GPS receiver and initializes the GPS receiver.

Normally, customers need not set this information.

Use the following procedure to send Master Reset.

- (a) Display the **INSTALLATION** menu by pressing the **[MENU]** key in long mode, select **GPS**, **GPS SETTING**, **MASTER RESET** and press **[JOG DIAL]** or **[ACQ/ENT]**.
- (b) When the following menu is displayed, select **ON** using **[JOG DIAL]**. TX COMMAND described in Item 9 is automatically starts and the setting of master reset is sent to the GPS receiver. The procedure is completed when "COMPLETE!" is displayed. If transmission fails, "TX FAILED!" is displayed. In this case, start the procedure from (a) again.

Note

The setting that was set to ON in (b) is reset automatically to **OFF** after transmission of TX COMMAND.

GPS SETTING	
POSITION	N 36° 36.000' E136° 36.000'
ANTENNA HEIGHT	10M
GEODETTIC DATUM	WGS-84
FIX MODE	AUTO
HDOP LEVEL	10
AVERAGE	MANUAL 2S
EXCLUDE SAT	00 00 00
MASTER RESET	00 00 00
OFF	
ON	

9. Sending updated set values [MENU]

This function sends the information from item 1 to item 8 that is set in GPS to a GPS receiver. The values set in items 1 to 8 are not set in the GPS receiver unless this transmission operation is performed even if the values are changed on the menu.

Use the following procedure to set a prohibited satellite number.

- (a) Display the **INSTALLATION** menu by pressing the **[MENU]** key in long mode, select **GPS**, **GPS SETTING**, **TX COMMAND** and press **[JOG DIAL]** or **[ACQ/ENT]**.
- (b) When the following menu is displayed and transmission starts, message "TRANSMIT ..." is displayed. When transmission is completed successfully, "COMPLETE!" is displayed. If transmission fails, "TX FAILED!" is displayed. In this case, start the procedure from (a) again.

GPS SETTING	
POSITION	N 36° 36.000'
	E136° 36.000'
ANTENNA HEIGHT	10M
GEODETTIC DATUM	WGS-84
FIX MODE	AUTO
HDOP LEVEL	10
AVERAGE	MANUAL 2S
EXCLUDE SAT	00 00 00
TX COMMAND	00 00 00
TRANSMIT...	
COMPLETE!	

10. Setting UTC time [MENU]

This function sends UTC (world time) to a GPS receiver.

Use the following procedure to set the UTC setting to a GPS receiver.

- Display the **INSTALLATION** menu by pressing the **[MENU]** key in long mode, select **[GPS]**, **[GPS SETTING2]**, **[UTC]** and press **[JOG DIAL]** or **[ACQ/ENT]**.
- When the following menu is displayed, change the values set in the year, month, day, hour, minute, and second in that sequence using **[JOG DIAL]**, determine each change by pressing **[JOG DIAL]** or **[ACQ/ENT]** and end the operation.

GPS SETTING2	
UTC	2003/01/23
2003/01/23	23:59:59
23:59:59	+00:00
TX COMMAND	

11. Setting a UTC time difference [MENU]

This function sends a time difference with UTC (world time) to a GPS receiver.

Use the following procedure to set the time difference with UTC to a GPS receiver.

- Display the **INSTALLATION** menu by pressing the **[MENU]** key in long mode, select **[GPS]**, **[GPS SETTING2]**, **[TIME DIFF.]** and press **[JOG DIAL]** or **[ACQ/ENT]**.
- When the following menu is displayed, set a time difference by changing the values by turning **[JOG DIAL]** and end the operation by pressing **[JOG DIAL]** or **[ACQ/ENT]**.

GPS SETTING2	
UTC	2003/01/23
	23:59:59
TIME DIFF.	+00:00
+00:00	

12. Sending updated setting values [MENU]

This function sends setting information of items 10 and 11 to GPS to a GPS receiver.

The setting values of items 10 and 11 are not set in the GPS receiver without this transmission operation, even if they are changed and set on the menu.

Use the following procedure to set updated setting values.

- (a) Display the **INSTALLATION** menu by pressing the **[MENU]** key in long mode, select **GPS**, **GPS SETTING2**, **TX COMMAND** and press **[JOG DIAL]** or **[ACQ/ENT]**.
- (b) When the following menu is displayed and transmission starts, message "TRANSMIT..." is displayed. If the transmission completes successfully, "COMPLETE!" is displayed. If the transmission fails, "TX FAILED" is displayed. In this case, starts the procedure from (a) again.

GPS SETTING2	
UTC	2003/01/23
TX COMMAND	23:59:59
TRANSMIT...	+00:00
COMPLETE!	

9.8.17 Setting information in a DGPS receiver

Set initial values in a DGPS receiver (differential GPS receiver of JRC).

1. Setting a DPGS mode [MENU]

This function sends the mode setting of a DGPS receiver to the DGPS receiver.

Use the following procedure to set the mode setting of a DGPS receiver to the DGPS receiver.

Normally, customers need not set this information.

- Display the **INSTALLATION** menu by pressing the **[MENU]** key in long mode, select **DGPS**, **DGPS SETTING**, **MODE** and press **[JOG DIAL]** or **[ACQ/ENT]**.
- When the following menu is displayed, select either **MANUAL** or **AUTO** by turning **[JOG DIAL]** and end the operation by pressing **[JOG DIAL]** or **[ACQ/ENT]**.

DGPS SETTING	
MODE	AUTO
MANUAL	288.0KHZ
AUTO	200BPS
TX COMMAND	

2. Setting a frequency used by a beacon station [MENU]

This function sends the frequency set for a beacon station to a DGPS receiver.

A frequency of a beacon station can be set in 0.5kHz steps within the range from 283.5kHz to 325.5kHz.

Use the following procedure to set a frequency used for a beacon station to a DGPS receiver.

- Display the **INSTALLATION** menu by pressing the **[MENU]** key in long mode, select **GPS**, **DGPS SETTING**, **FREQUENCY** and press **[JOG DIAL]** or **[ACQ/ENT]**.
- When the following menu is displayed, set a frequency by turning **[JOG DIAL]** and end the operation by pressing **[JOG DIAL]** or **[ACQ/ENT]**.

DGPS SETTING	
MODE	AUTO
FREQUENCY	288.0KHZ
288.0KHZ	200BPS
DGPS MODE	ON
TX COMMAND	

3. Setting a baud rate for communication with a beacon station [MENU]

This function sends the baud rate that is set for communication with a beacon station to a DGPS receiver.

Three baud rates are available for communication with a beacon station, 50, 100, and 200BPS.

Use the following procedure to set a baud rate for communication with a beacon station to a DGPS receiver.

- Display the **INSTALLATION** menu by pressing the **[MENU]** key in long mode, select **GPS**, **DGPS SETTING**, **BAUDRATE** and press **[JOG DIAL]** or **[ACQ/ENT]**.
- When the following menu is displayed, select **50BPS**, **100BPS**, or **200BPS** by turning **[JOG DIAL]** and end the operation by pressing **[JOG DIAL]** or **[ACQ/ENT]**.

DGPS SETTING	
MODE	AUTO
FREQUENCY	288.0KHZ
BAUDRATE	200BPS
200BPS	ON
TX COMMAND	

4. Setting a DPGS mode [MENU]

This function sends the DPGS ON/OFF (GPS mode) setting to a DGPS receiver.

When the DPGS mode is set to ON, high precision information can be obtained using the information from a beacon station.

When the DPGS mode is set to OFF, information can be obtained with the same precision as for GPS.

Use the following procedure to set the DPGS mode to ON/OFF.

- Display the **INSTALLATION** menu by pressing the **[MENU]** key in long mode, select **GPS**, **DGPS SETTING**, **DGPS MODE** and press **[JOG DIAL]** or **[ACQ/ENT]**.
- When the following menu is displayed, select either **OFF** or **ON** by turning **[JOG DIAL]** and end the operation by pressing **[JOG DIAL]** or **[ACQ/ENT]**.

DGPS SETTING	
MODE	AUTO
FREQUENCY	288.0KHZ
DGPS MODE	200BPS
OFF	ON
ON	

5. Sending updated setting values [MENU]

This function sends the information of items 1 to 4 that was set to GPS to a GPS receiver.

The values sets in items 1 to 4 are not set in the GPS receiver without this transmission operation even if the values are changed and set on the menu.

Use the following procedure to send updated setting values to a GPS receiver.

- Display the **INSTALLATION** menu by pressing the **[MENU]** key in long mode, select **GPS**, **DGPS SETTING**, **TX COMMAND** and press **[JOG DIAL]** or **[ACQ/ENT]**.
- When the following menu is displayed and transmission starts, message "TRANSMIT..." is displayed. If the transmission completes successfully, "COMPLETE!" is displayed. If the transmission fails, "TX FAILED!" is displayed. In this case, start the procedure from (a) again.

DGPS SETTING	
MODE	AUTO
TX COMMAND	288.0KHZ
TRANSMIT...	200BPS
COMPLETE!	

9.8.18 Setting information in a WAAS receiver

Set initial values in WAAS receiver (WAAS receiver of JRC). A WAAS receiver demonstrates high precision position fixing from GPS by receiving, from satellites also, the same information as that received from the DGPS beacon station.

1. Setting a WAAS mode [MENU]

This function sends, to a DGPS receiver, the setting information as to whether differential information of a WAAS receiver is obtained from a beacon or a satellite.

Use the following procedure to set information as to whether differential information is received from a beacon or a satellite.

- Display the **INSTALLATION** menu by pressing the **[MENU]** key in long mode, select **GPS**, **WAAS SETTING**, **MODE** and press **[JOG DIAL]** or **[ACQ/ENT]**.
- When the following menu is displayed, select **BEACON**, **WAAS**, or **AUTO** by turning **[JOG DIAL]** and end the operation by pressing **[JOG DIAL]** or **[ACQ/ENT]**.

WAAS SETTING	
MODE	AUTO
BEACON	ON
WAAS	NO USE
AUTO	AUTO
TX COMMAND	

2. Setting a position fixing satellite [MENU]

This function sends, to a WAAS receiver, the setting information as to whether a WAAS satellite is used as a position fixing satellite. The function also sets information as to whether a WAAS satellite is used as a satellite for position fixing.

Use the following procedure to set information as to whether differential information is received from a beacon or a satellite.

- Display the **INSTALLATION** menu by pressing the **[MENU]** key in long mode, select **GPS**, **WAAS SETTING**, **RANGING** and press **[JOG DIAL]** or **[ACQ/ENT]**.
- When the following menu is displayed, select **OFF** (not used) or **ON** (used) by turning **[JOG DIAL]** and end the operation by pressing **[JOG DIAL]** or **[ACQ/ENT]**.

WAAS SETTING	
MODE	AUTO
RANGING	ON
OFF	NO USE
ON	AUTO
TX COMMAND	

3. Setting information whether a prohibited satellite can be used [MENU]

This function sends, to a WAAS receiver, the setting information as to whether a prohibited WAAS satellite is used.

Use the following procedure to set information as to whether a prohibited WAAS satellite is used.

- (a) Display the **INSTALLATION** menu by pressing the **[MENU]** key in long mode, select **GPS**, **WAAS SETTING**, **NG WAAS**, and press **[JOG DIAL]** or **[ACQ/ENT]**.
- (b) When the following menu is displayed, select **NO USE** or **USE** by turning **[JOG DIAL]** and end the operation by pressing **[JOG DIAL]** or **[ACQ/ENT]**.

WAAS SETTING	
MODE	AUTO
RANGING	ON
NG WAAS	NO USE
NO USE	AUTO
USE	

4. Setting a satellite number [MENU]

This function sends the setting of a WAAS satellite that is used to a WAAS receiver. A number between 120 and 138 can be selected automatically.

Use the following procedure to set a number of the WAAS satellite that is used.

- (a) Display the **INSTALLATION** menu by pressing the **[MENU]** key in long mode, select **GPS**, **WAAS SETTING**, **WAAS NO.**, and press **[JOG DIAL]** or **[ACQ/ENT]**.
- (b) When the following menu is displayed, select either a number between **120** and **138** or **AUTO** by turning **[JOG DIAL]** and end the operation by pressing **[JOG DIAL]** or **[ACQ/ENT]**.

WAAS SETTING	
MODE	AUTO
RANGING	ON
NG WAAS	NO USE
WAAS NO.	AUTO
AUTO	

5. Sending updated setting values [MENU]

This function sends the information of items 1 to 4 that was set to WAAS to a WAAS receiver. The values that are set in items 1 to 4 are not set in the GPS receiver without this transmission operation even if the values are changed and set on the menu.

Use the following procedure to send updated setting values to a GPS receiver.

- (a) Display the **INSTALLATION** menu by pressing the **[MENU]** key in long mode, select **GPS**, **WAAS SETTING**, **TX COMMAND** and press **[JOG DIAL]** or **[ACQ/ENT]**.
- (b) When the following menu is displayed and transmission starts, message "TRANSMIT..." is displayed. If the transmission completes successfully, "COMPLETE!" is displayed. If the transmission fails, "TX FAILED!" is displayed. In this case, start the procedure from (a) again.

WAAS SETTING	
MODE	AUTO
RANGING	ON
TX COMMAND	NO USE
TRANSMIT...	AUTO
COMPLETE!	

9.8.19 Displaying GPS receiving status

This function displays receiving status of the GPS receiver (GPS/DGPS/WAAS receiver) connected now.

Use the following procedure to display the GPS receiver status.

- Display the **INSTALLATION** menu by pressing the **[MENU]** key in long mode, select **GPS RECEIVING STATUS**, and press **[JOG DIAL]** or **[ACQ/ENT]**.
- Since the GPS receiving status is displayed as follows, grasp the situation of the satellites that are carried out positioning now.

GPS RECEIVING STATUS				
DGPS				
SAT NO.	24	25		
AZIMUTH	245.9°	123.5°	°	°
ELV.	81.0°	45.4°	°	°
SNR	43	45		
SAT NO.				
AZIMUTH	°	°	°	°
ELV.				
SNR				
SAT NO.				
AZIMUTH	°	°	°	°
ELV.				
SNR				
VERSION	R26.00			
DOP	1			
ALTITUDE	65M			
RSSI	0			
BEACON	2003/01/01			
DATE/TIME	04:15:01			
(UTC)				

9.8.20 Initializing ATA [MENU]

Set the ATA function to ON/OFF.

Caution

- Even if the ATA function is set to ON in the menu shown below, the ATA function does not run unless the optional MARPA unit is installed. Do not set the ATA function to ON unless a MARPA unit is installed.

Use the following procedure to set the ATA function to ON or OFF.

- Display the **INSTALLATION** menu by pressing the **[MENU]** key in long mode, select **ATA SETTING** and **ATA**, and press **[JOG DIAL]** or **[ACQ/ENT]**.
- When the following menu is displayed, select **ON** to use the ATA function and **OFF** not to use the ATA function and end the operation by pressing **[JOG DIAL]** or **[ACQ/ENT]**.

ATA SETTING	
ATA	OFF
OFF	64
ON	64
LEVEL G	64
VECTOR CONST	4
AUTO ACQ	OFF
TEST VIDEO	OFF
NUMBERING	AUTO
GATE DISP	OFF

Other items are available on the ATA menu of the second level. Other items and the operation method of ATA are included in the MARPA unit that is sold separately. See the instruction manual of the unit.

9.8.21 Setting a course data input type [MENU]

Select course data input.

As course data, manual input values, course information from GPS, and gyro or magnetic compass input data are available. For manual input, manual course information that is set in the next item can be used.

Use the following procedure to set the ATA function to ON or OFF.

- (a) Display the **INSTALLATION** menu by pressing the **[MENU]** key in long mode, select **DATA/IN OUT** and **COURSE IN**, and press **[JOG DIAL]** or **[ACQ/ENT]**.
- (b) When the following menu is displayed, select **MANUAL**, **GPS**, or **COMPASS GYRO** and end the operation by pressing **[JOG DIAL]** or **[ACQ/ENT]**.

DATA/ IN OUT	
COURSE IN	COMPASS GYRO
MANUAL	000°
GPS	GPS BT
COMPASS GYRO	00.0 KT
POSITION IN	GPS
MANUAL POS.	N 36° 36.000'
	E136° 36.000'
COMPASS PORT	JLR-10 (9600)
2ND PANEL	DISABLE
NMEA OUT	>
CALIBRATION	>

Note

COG can be input as the course information from GPS and HDM, HDT, HDG, and VHW can be input as the course information from a magnetic compass.

9.8.22 Setting manual course data [MENU]

When Manual is selected as course data input on the menu shown above, enter a manual course.

Use the following procedure to set manual course data input.

- Display the **INSTALLATION** menu by pressing the **[MENU]** key in long mode, select **DATA/IN OUT** and **MANUAL COURSE** and press **[JOG DIAL]** or **[ACQ/ENT]**.
- When the following menu is displayed, select a course by turning **[JOG DIAL]** and end the operation by pressing **[JOG DIAL]** or **[ACQ/ENT]**.

DATA/ IN OUT	
COURSE IN	COMPASS GYRO
MANUAL COURSE	000°
000°	GPS BT
MANUAL SPEED	00.0 KT
POSITION IN	GPS
MANUAL POS.	N 36° 36.000'
	E136° 36.000'
COMPASS PORT	JLR-10 (9600)
2ND PANEL	DISABLE
NMEA OUT	>
CALIBRATION	>

9.8.23 Setting a speed data input type [MENU]

Select speed data input.

As speed data, a manual input value, a ground speed from GPS, and a sea speed from an optional NSK unit are available. For manual input, manual speed information that is set in the following item can be used.

Use the following procedure to set speed data input.

- Display the **INSTALLATION** menu by pressing the **[MENU]** key in long mode, select **DATA/IN OUT** and **SPEED IN** and press **[JOG DIAL]** or **[ACQ/ENT]**.
- When the following menu is displayed, select **MANUAL**, **GPS BT**, or **COMPASS WT** and end the operation by pressing **[JOG DIAL]** or **[ACQ/ENT]**.

DATA/ IN OUT	
COURSE IN	COMPASS GYRO
MANUAL COURSE	000°
SPEED IN	GPS BT
MANUAL	00.0 KT
GPS BT	GPS
COMPASS WT	N 36° 36.000'
	E136° 36.000'
COMPASS PORT	JLR-10 (9600)
2ND PANEL	DISABLE
NMEA OUT	>
CALIBRATION	>

Note

COMPASS WT runs only when an optional NSK unit is connected and a signal is input to the NSK unit from electromagnetic log.

9.8.24 Setting manual speed data [MENU]

Input a manual course required when manual is selected as the speed data input on the menu shown above.

Use the following procedure to set speed data input.

- Display the **INSTALLATION** menu by pressing the **[MENU]** key in long mode, select **DATA/IN OUT** and **MANUAL SPEED** and press **[JOG DIAL]** or **[ACQ/ENT]**.
- When the following menu is displayed, select a course by turning **[JOG DIAL]** and end the operation by pressing **[JOG DIAL]** or **[ACQ/ENT]**.

DATA/ IN OUT	
COURSE IN	COMPASS GYRO
MANUAL COURSE	000°
SPEED IN	GPS BT
MANUAL SPEED	00.0 KT
00.0 KT	GPS
MANUAL POS.	N 36° 36.000'
	E136° 36.000'
COMPASS PORT	JLR-10 (9600)
2ND PANEL	DISABLE
NMEA OUT	>
CALIBRATION	>

9.8.25 Setting own ship's position input selection [MENU]

This function enables selection of position information from GPS or manual input as the method for inputting an own ship's position. When GPS is selected, position information from GPS is used and when manual is selected, the position information that is set by manual input shown in the next item is used.

Use the following procedure to select own ship's position input selection.

- Display the **INSTALLATION** menu by pressing the **[MENU]** key in long mode, select **DATA/IN OUT** and **POSITION IN** and press **[JOG DIAL]** or **[ACQ/ENT]**.
- When the following menu is displayed, select **MANUAL** or **GPS** and end the operation by pressing **[JOG DIAL]** or **[ACQ/ENT]**.

DATA/ IN OUT	
COURSE IN	COMPASS GYRO
MANUAL COURSE	000°
SPEED IN	GPS BT
MANUAL SPEED	00.0 KT
POSITION IN	GPS
MANUAL	N 36° 36.000'
GPS	E136° 36.000'
COMPASS PORT	JLR-10 (9600)
2ND PANEL	DISABLE
NMEA OUT	>
CALIBRATION	>

Note

The signals of NMEA0183 which can be received from J3 of GPS port are as follows.

GGA, GLL, VTG, RMB

9.8.26 Setting own ship's position input [MENU]

Set manual input of own ship's position that is required when manual is selected in the own ship's position input from the menu shown above.

Use the following procedure to set speed data input.

- (a) Display the **INSTALLATION** menu by pressing the **[MENU]** key in long mode, select **DATA/IN OUT** and **MANUAL POS.** and press **[JOG DIAL]** or **[ACQ/ENT]**.
- (b) When the following menu is displayed, set the values of South and North of the latitude, the unit of degree, the unit of minute, and the unit of second in that sequence by changing the values using the **[JOG DIAL]** and determine each value by pressing **[JOG DIAL]** or **[ACQ/ENT]**. When the information up to the second of latitude has been confirmed, the cursor moves to the longitude line. Change the values of East and West of the longitude, the unit of degree, the unit of second in that sequence by turning **[JOG DIAL]** and determine each value by pressing **[JOG DIAL]** or **[ACQ/ENT]**.

DATA/ IN OUT	
COURSE IN	COMPASS GYRO
MANUAL COURSE	000°
SPEED IN	GPS BT
MANUAL SPEED	00.0 KT
POSITION IN	GPS
MANUAL POS.	N 36° 36.000'
N 36° 36.000'	E136° 36.000'
E136° 36.000'	JLR-10 (9600)
2ND PANEL	DISABLE
NMEA OUT >	
CALIBRATION >	

9.8.27 Setting a compass input baud rate [MENU]

Set a baud rate of a compass port.

Optional NSK unit : 9600BPS

GPS compass JLR-10 of JRC : 9600BPS

NEMA-0183 input equipment such as electronic compass : 4800BPS

Use the following procedure to set speed data input.

- (a) Display the **INSTALLATION** menu by pressing the **[MENU]** key in long mode, select **DATA/IN OUT** and **COMPASS PORT** and press **[JOG DIAL]** or **[ACQ/ENT]**.
- (b) When the following menu is displayed, select **NSK (9600)**, **JLR-10 (9600)**, or **COMPASS (4800)** and end the operation by pressing **[JOG DIAL]** or **[ACQ/ENT]**.

DATA/ IN OUT	
COURSE IN	COMPASS GYRO
MANUAL COURSE	000°
SPEED IN	GPS BT
MANUAL SPEED	00.0 KT
POSITION IN	GPS
MANUAL POS.	N 36° 36.000'
	E136° 36.000'
COMPASS PORT	JLR-10 (9600)
NSK (9600)	DISABLE
JLR-10 (9600)	
COMPASS (4800)	

The signal formats which can be input from J5 of COMPSS port are as follows.

NSK (9600) : JRC original format

JLR-10 (9600) : JRC original format

COMPASS (4800) : MNEA0183 signal, HDT, HDG, VHW, VHW, HDM

9.8.28 Setting connection of the 2nd keyboard [MENU]

Set the presence or absence of an optional 2nd keyboard.

Set the following information when connecting an optional 2nd keyboard.

Use the following procedure to use the 2nd keyboard.

- Display the **INSTALLATION** menu by pressing the **[MENU]** key in long mode, select **DATA/IN OUT** and **2ND PANEL** and press **[JOG DIAL]** or **[ACQ/ENT]**.
- When the following menu is displayed, select **DISABLE** or **ENABLE** and end the operation by pressing **[JOG DIAL]** or **[ACQ/ENT]**.

DATA/ IN OUT	
COURSE IN	COMPASS GYRO
MANUAL COURSE	000°
SPEED IN	GPS BT
MANUAL SPEED	00.0 KT
POSITION IN	GPS
MANUAL POS.	N 36° 36.000'
	E136° 36.000'
COMPASS PORT	JLR-10 (9600)
2ND PANEL	DISABLE
DISABLE	
ENABLE	

9.8.29 Setting a NMEA data output frequency [MENU]

When an output frequency of NMEA-0183 data that is output from a NMEA output port is set and the **[CSR POS]** key is pressed, set ON/OFF for the output of RSD data or OSD data.

An output frequency between 0 second to 99 seconds (0: output OFF) can be set.

Note

See 3, "NMEA0183 standard input/output sentences" of 9.3.9, "Connecting a GPS receiver and NMEA equipment".

Use the following procedure to set a NMEA data output frequency

- (a) Display the **INSTALLATION** menu by pressing the **[MENU]** key in long mode, select **DATA/IN OUT** and **NMEA OUT** and press **[JOG DIAL]** or **[ACQ/ENT]**.
- (b) When the following menu is displayed, select the output times to be changed from **GGA**, **GLL**, **RMC**, **VTG**, **OSD**, **RSD**, and **TTM** by turning **[JOG DIAL]** and press **[JOG DIAL]** or **[ACQ/ENT]**.
- (c) Set an output frequency by turning **[JOG DIAL]** and end the operation by pressing **[JOG DIAL]** or **[ACQ/ENT]**.

NMEA OUT	
GGA	OSEC
OSEC	OSEC
RMC	OSEC
VTG	OSEC
OSD	OSEC
RSD	OSEC
TTM	OSEC
CURSOR POS.	OFF

Example : Changing GGA output time

Use the following procedure to set the [CSR POS] key output to ON or OFF.

- (a) Select **CURSOR POS.** on the menu shown in (b) above and press **[JOG DIAL]** or **[ACQ/ENT]**.
- (b) Select **OFF** or **ON** by turning **[JOG DIAL]** and end the operation by pressing **[JOG DIAL]** or **[ACQ/ENT]**.

NMEA OUT	
GGA	OSEC
GLL	OSEC
RMC	OSEC
VTG	OSEC
OSD	OSEC
CURSOR POS.	OSEC
OFF	OSEC
ON	OFF

9.8.30 Setting selection of a magnetic azimuth sensor correction value [MENU]

Set whether correction values are set manually or RMC data is used when connecting a magnetic azimuth sensor.

Select whether correction values are set manually using a magnetic compass or RMC DATA is used.

Note

When RMC data is set in the following settings and RMC data is not set, 0 degree is assumed for the correction value.

Use the following procedure to set selection of a magnetic azimuth sensor correction value.

- (a) Display the **INSTALLATION** menu by pressing the **[MENU]** key in long mode, select **DATA/IN OUT**, **CALIBRATION**, and **MAG CORR.** and press **[JOG DIAL]** or **[ACQ/ENT]**.

- (b) When the following menu is displayed, select **MANUAL** or **RMC** by turning **[JOG DIAL]** and end the operation by pressing **[JOG DIAL]** or **[ACQ/ENT]**.

CALIBRATION	
MAG CORR.	MANUAL
MANUAL	0.0 °
RMC	

9.8.31 Setting manual data for a compass correction value [MENU]

Input a manual correction value as the manual correction data input as shown above.

Use the following procedure to set selection of a magnetic azimuth sensor correction value.

- (a) Display the **INSTALLATION** menu by pressing the **[MENU]** key in long mode, select **DATA/IN OUT**, **CALIBRATION**, and **MANUAL** and press **[JOG DIAL]** or **[ACQ/ENT]**.
- (b) When the following menu is displayed, set a correction value by turning **[JOG DIAL]** and end the operation by pressing **[JOG DIAL]** or **[ACQ/ENT]**.

CALIBRATION	
MAG CORR.	MANUAL
MANUAL	0.0 °
0.0 °	

9.8.32 Setting a PC output baud rate [MENU]

Set a baud rate of the output port for a NEMA data personal computer.

This setting becomes valid when the 2nd keyboard that was described above is not connected (OFF).

Four types of baud rates are available; 4800BPS, 9600BPS, 19200BPS, and 38400BPS.

Use the following procedure to set a PC output baud rate.

- (a) Display the **INSTALLATION** menu by pressing the **[MENU]** key in long mode, select **BAUD RATE** and **PC** and press **[JOG DIAL]** or **[ACQ/ENT]**.
- (b) When the following menu is displayed, select **4800**, **9600**, **19200**, or **38400** by turning **[JOG DIAL]** and end the operation by pressing **[JOG DIAL]** or **[ACQ/ENT]**.

BAUD RATE	
PC	4800
4800	4800

9.8.33 Setting a keyboard port baud rate [MENU]

Set a baud rate of a keyboard port.

When a 2nd keyboard is connected (ON), the same baud rate as the keyboard port is set for the PC port that was described above.

Four types of baud rates are available; 4800BPS, 9600BPS, 19200BPS, and 38400BPS.

Use the following procedure to set a keyboard port baud rate.

- (a) Display the **INSTALLATION** menu by pressing the **[MENU]** key in long mode, select **BAUD RATE** and **PANEL** and press **[JOG DIAL]** or **[ACQ/ENT]**.

- (b) When the following menu is displayed, select **4800**, **9600**, **19200**, or **38400** by turning **[JOG DIAL]** and end the operation by pressing **[JOG DIAL]** or **[ACQ/ENT]**.

BAUD RATE	
PANEL	4800
4800	4800

9.8.34 Setting a display direction of the indicator [MENU]

Set a display direction of the indicator.

Four indicator display direction are available, 0 degree: HORIZONTAL, 90 degrees: VERTICAL-RIGHT, 180 degrees: INVERSION, and 270 degrees: VERTICAL-LEFT.

Use the following procedure to set a display direction of the indicator.

- (a) Display the **INSTALLATION** menu by pressing the **[MENU]** key in long mode, select **DISPLAY MOUNT** and press **[JOG DIAL]** or **[ACQ/ENT]**.
- (b) When the following menu is displayed, select **HORIZONTAL**, **VERTICAL-RIGHT**, **INVERSION**, or **VERTICAL-LEFT** by turning **[JOG DIAL]** and end the operation by pressing **[JOG DIAL]** or **[ACQ/ENT]**.

Note

The above function is also set when the system is started by pressing one of the following keys at Power ON.

[AUTO-TUNE] : 0 degree : HORIZONTAL

[AUTO-RAIN] : 90 degrees : VERTICAL-RIGHT

[AUTO-SEA] : 180 degrees : INVERSION

[GAIN/PL] : 270 degrees : VERTICAL-LEFT

DISPLAY MOUNT	
GYRO SETTING	123.4°
SIMULATION	OFF
RADAR	>
GPS	>
ATA SETTING	>
DATA/IN OUT	>
DISPLAY MOUNT	
HORIZONTAL	
VERTICAL-RIGHT	
INVERSION	
VERTICAL-LEFT	

9.8.35 Setting a display timing of the indicator [MENU]

Set a horizontal/vertical display timing of the indicator.

A value between 130 and 160 can be set for a horizontal timing and a value between 20 and 50 can be set for a vertical timing.

Use the following procedure to set horizontal display timing of the indicator.

- (a) Display the **INSTALLATION** menu by pressing the **[MENU]** key in long mode, select **LCD SETTING** and **HS DISP SATART** and press **[JOG DIAL]** or **[ACQ/ENT]**.
- (b) When the following menu is displayed, set a required value by turning **[JOG DIAL]** and end the operation by pressing **[JOG DIAL]** or **[ACQ/ENT]**.



Use the following procedure to set vertical display timing of the indicator.

- Display the **INSTALLATION** menu by pressing the **[MENU]** key in long mode, select **LCD SETTING** and **VS DISP SATART** and press **[JOG DIAL]** or **[ACQ/ENT]**.
- When the following menu is displayed, set a required value by turning **[JOG DIAL]** and end the operation by pressing **[JOG DIAL]** or **[ACQ/ENT]**.



9.8.36 Setting reading/writing setting values to non-initialization memory [MENU]

Various setting values can be stored or read from the area where data is stored permanently even in non-initialization memory or the area is initialized.

Use the following procedure to write the setting into non-initialization memory.

- Display the **INSTALLATION** menu by pressing the **[MENU]** key in long mode, select **BACKUP MEMORY** and **STORE** and press **[JOG DIAL]** or **[ACQ/ENT]**.
- When the following menu is displayed, select **YES** to store data or **NO** not to store data by turning **[JOG DIAL]** and end the operation by pressing **[JOG DIAL]** or **[ACQ/ENT]**.



As a result of the operation, all the values that were set on the menu or by initialization are stored in a non-initialization memory and the non-initialization memory is not erased even if master reset operation is performed.

Therefore, before executing master reset, store the values in the non-initialization memory and after executing master reset, execute read processing that is described in the next item.

Use the following procedure to set read processing from non-initialization memory.

- When the following menu is displayed after execution of (a) indicated above, select **YES** to load data or **NO** not to store data by turning **[JOG DIAL]** and end the operation by pressing **[JOG DIAL]** or **[ACQ/ENT]**.

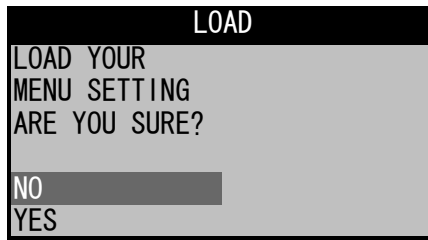

As a result of the operation indicated above, the data that was set by initialization is returned.

9.8.37 Initializing a menu storage area [MENU]

Initialize all the menu areas other than the initialization area (installation setting storage area).

Use the following procedure to initialize menu storage areas.

- (a) Display the menu by pressing the [MENU] key in long mode, select and press [JOG DIAL] or [ACQ/ENT].
- (b) When the following menu is displayed, select to initialize the areas or not to initialize the areas by turning [JOG DIAL] and end the operation by pressing [JOG DIAL] or [ACQ/ENT].

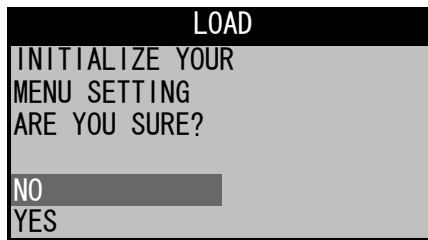

9.8.38 Displaying simulator images

Demonstration screens can be displayed on PPI by validating this function.

Use the following procedure to set a simulator mode.

- (a) Display the menu by pressing the [MENU] key in long mode, select and press [JOG DIAL] or [ACQ/ENT].
- (b) Using [JOG DIAL], invert characters when using a built-in simulator and when using an external simulator (NDW-51 and so on) among , , and , and end the operation by pressing [JOG DIAL] or [ACQ/ENT].

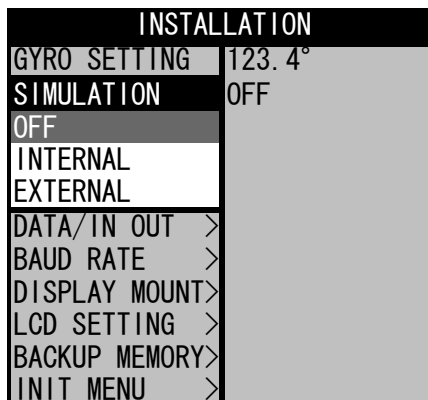

Caution

- This function becomes effective only when the radar is in preparation state.

When an external simulator is connected, set a special mode of the item and select ON.

9.8.39 Special mode

Use this function to select a mode that allows transmission with the safety switch or the motor line disconnected.

Set this mode for measuring a scanner unit power or transmitting signals by deactivating the scanner unit in external simulator mode.

Caution

- Since the following mode is used at maintenance or demonstration, this function can be used by service engineers only.

Use the following procedure to set horizontal display timing of the indicator.

- Display the INSTALLATION menu by pressing the **[MENU]** key in long mode, select RADAR, RADAR ADJUST, or MOTOR and press **[JOG DIAL]** or **[ACQ/ENT]**.
- Select OFF by turning **[JOG DIAL]** and end the operation by pressing **[JOG DIAL]** or **[ACQ/ENT]**.

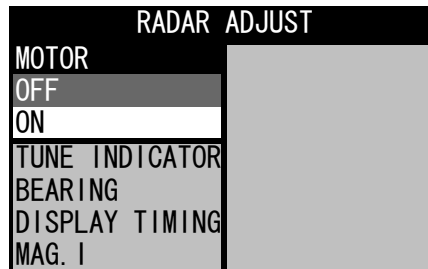

DANGER



When the above setting is set to OFF, microwaves are radiated even if the scanner unit is not rotating, it may cause death or a serious injury of any person. Therefore, utmost care is necessary. Make the setting is set ON after the required operation is completed.

9.9 Resetting Adjustments to the Initial State

When detecting any of the following problems, turn off the power once and then turn it on again.
Radar is busy.

The screen is unstable.

The keys are locked.

If the problem cannot be solved, initialize the equipment using the following procedure.

Caution

- When the equipment is initialized, the entire information is erased including the initialization menu.

- Press the **[STBY]** and **[TX/PRF]** keys together.
The power is turned off.
- Turn on the power by pressing **[STBY]** while pressing **[ACQ/ENT]** and **[MENU]**.

When the following menu is displayed, select **YES** by using **[JOG DIAL]** when initializing the equipment.

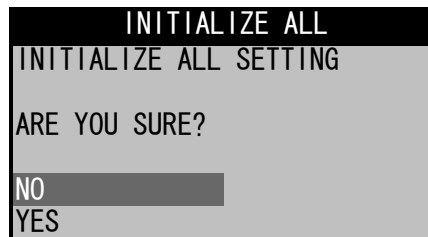

9.10 Maintenance

9.10.1 General maintenance

To operate radar equipment constantly in a good condition, the following maintenance is necessary. Maintain the equipment periodically. Periodic maintenance reduces failures.

The following common maintenance points are applied to each unit.

1. Cleaning the equipment

Remove dust, stains, and seawater from the cabinet as much as possible. Use a dry cloth for cleaning.

2. Checking the tightening of screws

Check the tightening of screws of assembly and component setting crews that are used for the equipment.

3. Checking connections

Check the cable connections between equipment units (scanner unit - processing unit, processing unit - power, processing unit - keyboard unit, processing unit - display unit, processing unit - optional equipment) if the equipment units are electrically connected.

DANGER



Make sure that the main power is turned off before maintaining the equipment. In particular, when a rectifier is used, a voltage is output from the rectifier even if the power of the display is turned off and the radar is stopped. This may cause failures of equipments, or death or a serious injury of any person by electric shock.

9.10.2 Scanner unit

DANGER



When checking a scanner unit for maintenance, make sure that the main power is turned off and the safety switch attached to the scanner unit is set to OFF. If the power is not turned off, failures of equipments may occur, and death or a serious injury of any person may occur by electric shock. And touching a rotating scanner unit may cause failures of equipments, or death or a serious injury of any person by electric shock.

CAUTION



Since the modulation section contains a magnetron with stored magnetism, do not place a lock or a magnetic card close to the modulation section. Otherwise, failures or data corruption may occur in such devices.

1. Radiation section

- (a) Radiation side of the radiation section (JMA-5104: All sides of the radome cover)

If JMA5106/JMA-5110 (entire area of the radiation section) is contaminated or damaged by smoke, dust, or paint, attenuation and reflection of waves occur, causing deterioration of radar performance. Check the radiation area occasionally and keep it clean by wiping with a soft cloth dipped with alcohol or moisturized cloth if it is dirty.

CAUTION



Do not use solvents such as thinner, gasoline, benzene, trichlene, and ketone. These solvents cause discoloration or deterioration.

2. Rotation driving section

(a) Greasing gears

Apply grease on the faces of the teeth of each gear using a spatula or brush. The more frequently greasing is applied, the longer the life span becomes, preventing the abrasion. Greasing is necessary at least once in six months.

Use "Mobilux 2" of Mobile Oil or equipment product for the grease.

(b) Driving motor

i) Attenuator

Greasing is not necessary unless there is oil leakage.

ii) Motor

The life span of the brush itself is 2000 hours. When the brush is worn out to a half of the entire length, replace it.

The communicator must be kept clean all the time. If carbon dust is stuck and cannot be removed with a dry cloth, polish the section with sand paper of No.150 to 400.

The carbon brush can be removed by removing the caps on both sides of the bottom of the motor.

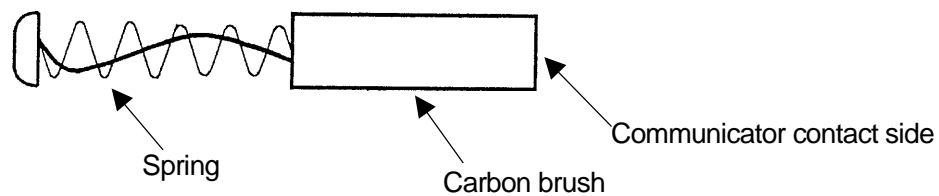

List of replacement carbon brushes

Scanner unit model name	Item name	Model name	JRC code	Replacement quantity
JMA-5104	–	–	–	Cannot be replaced
JMA-5106	Carbon brush	54531-1	BRXP05247	2
JMA-5110	Carbon brush	S00152-5C-70	BRXP00918	2

* Since the brush of JMA-5104 cannot be replaced, it must be replaced by motor ASSY.

(c) Mounting stand

Check the scanner unit mounting bolts occasionally and paint them every six months to prevent corrosion.

9.10.3 Display

Cleaning display

Caution

- When dust is attached on the LCD display area, the clarity deteriorates and the image becomes dark. Clean the surface with soft cloth (flannel or cotton) gently. The cloth can be dipped with an antistatic agent; however, do not rub the surface strongly.

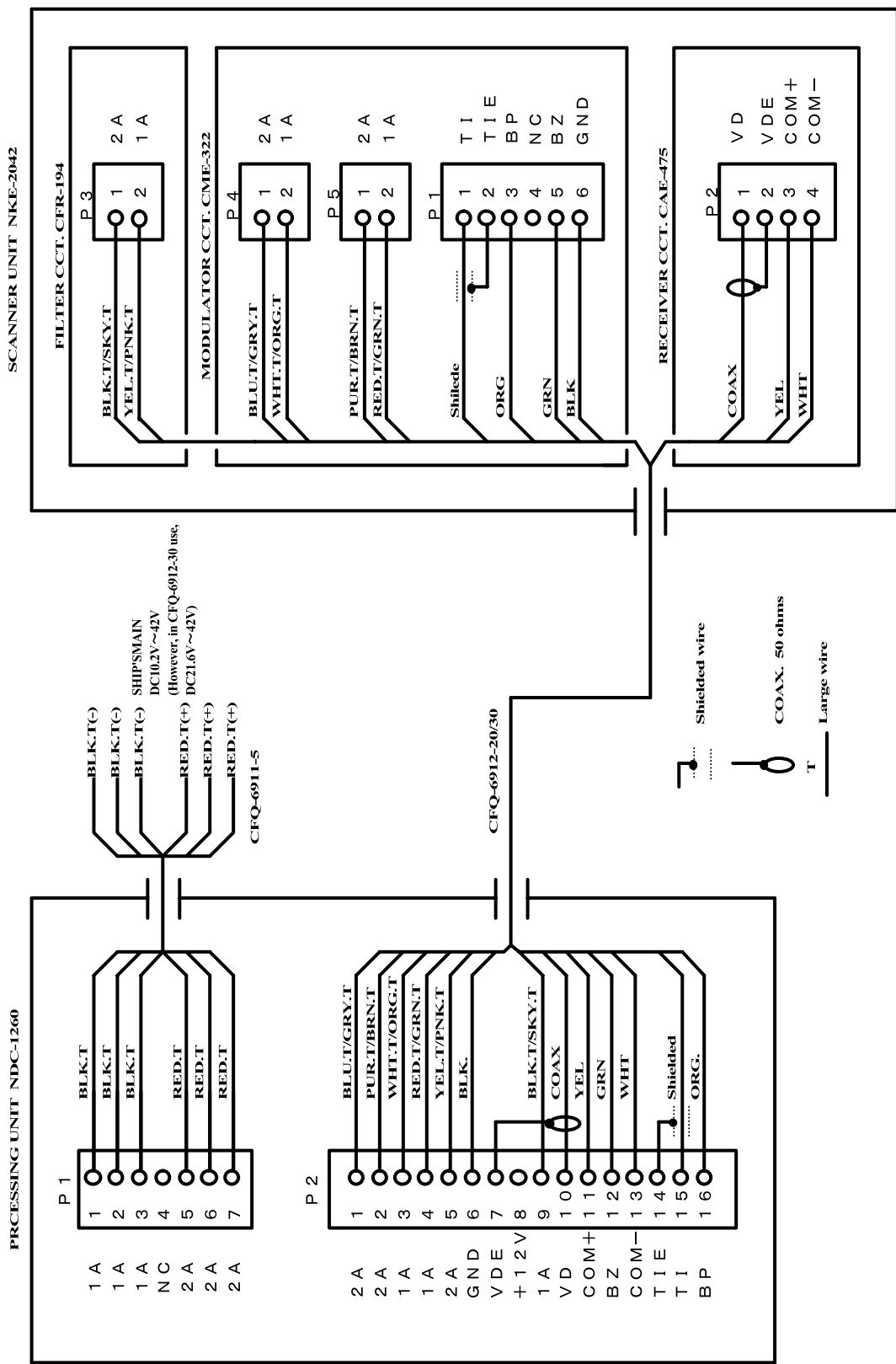

[Fig. 101 INTERCONNECTION DIAGRAM OF JMA-5104]

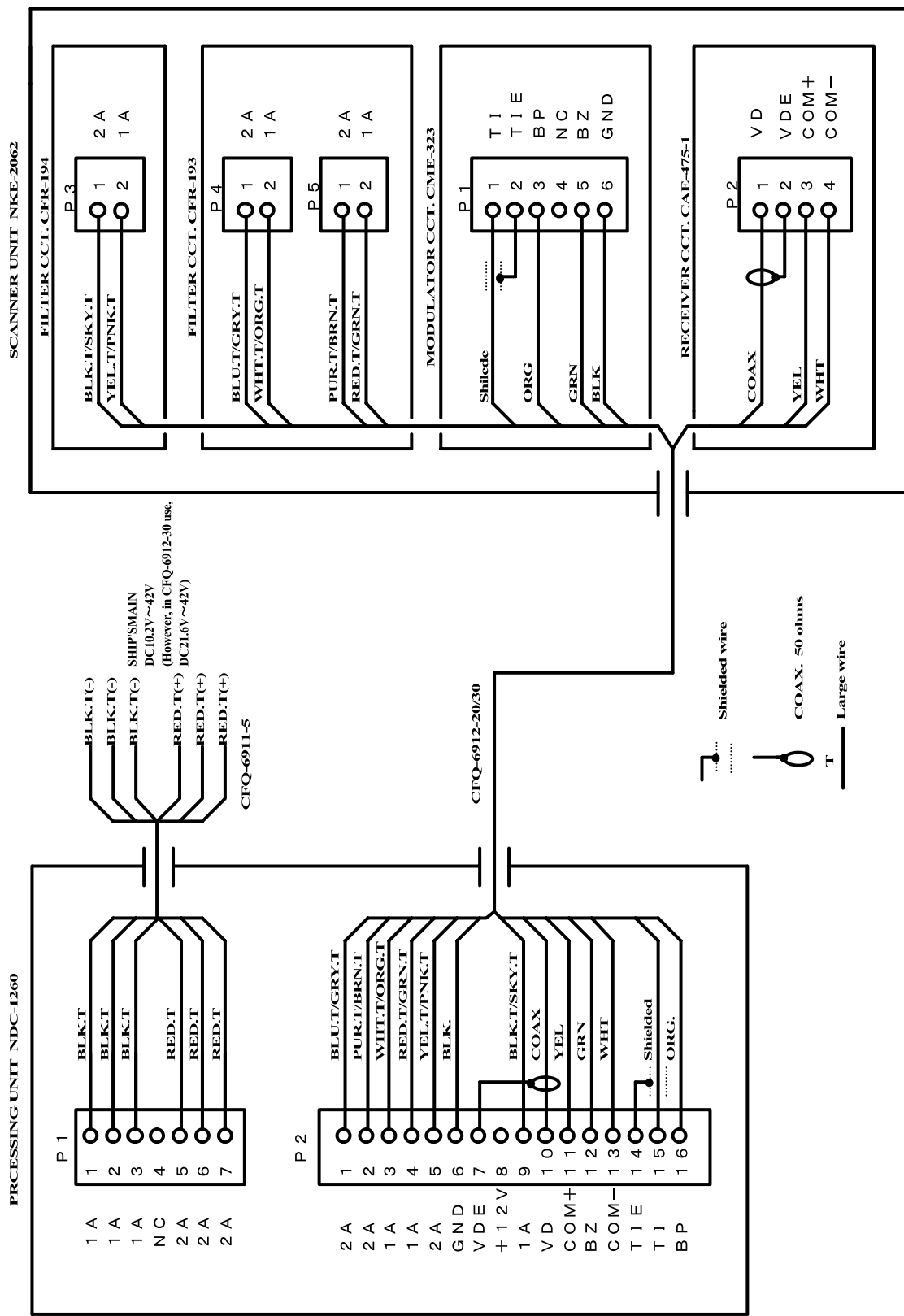

[Fig. 102 INTERCONNECTION DIAGRAM OF JMA-5106]

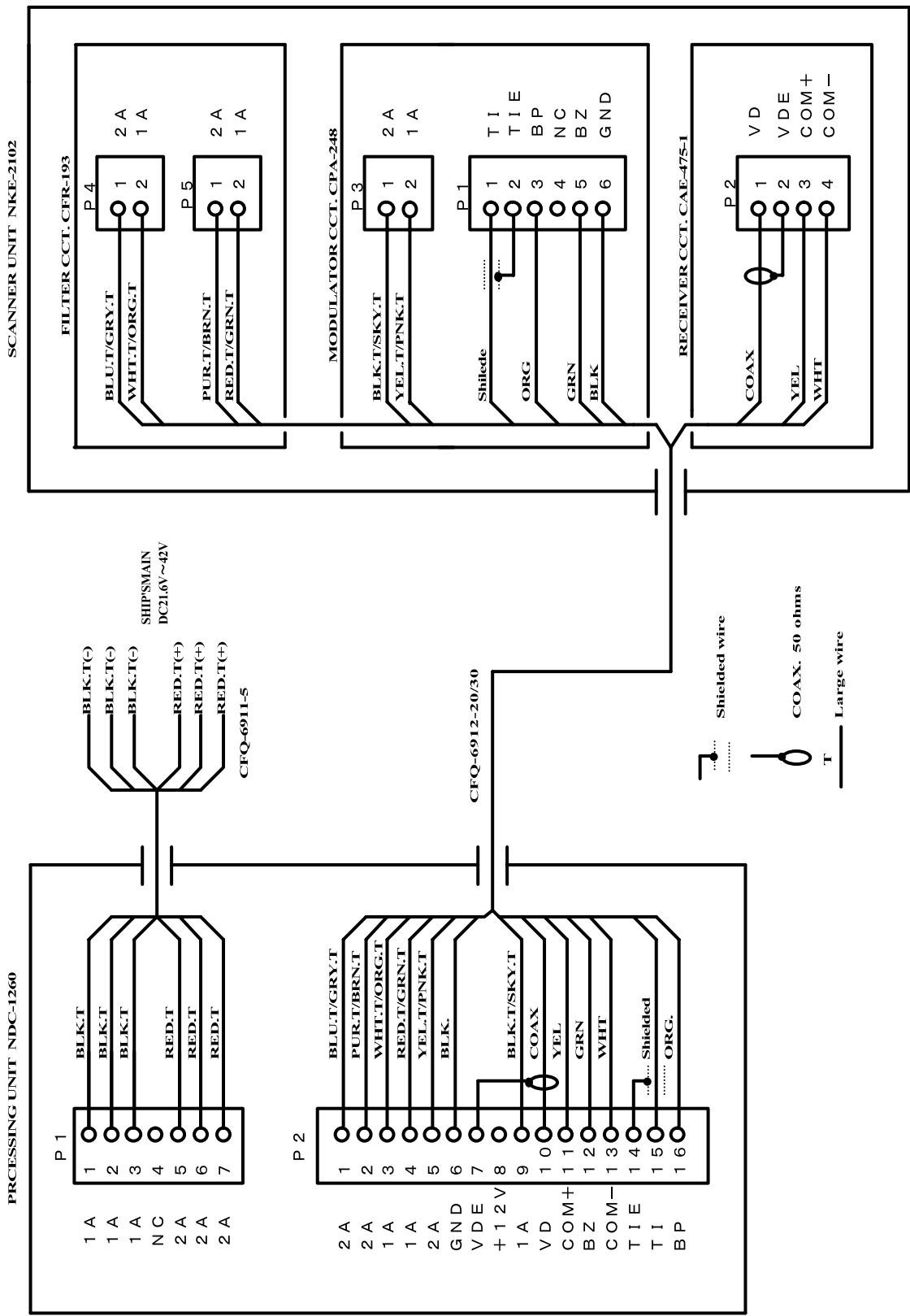

[Fig. 103 INTERCONNECTION DIAGRAM OF JMA-5110]

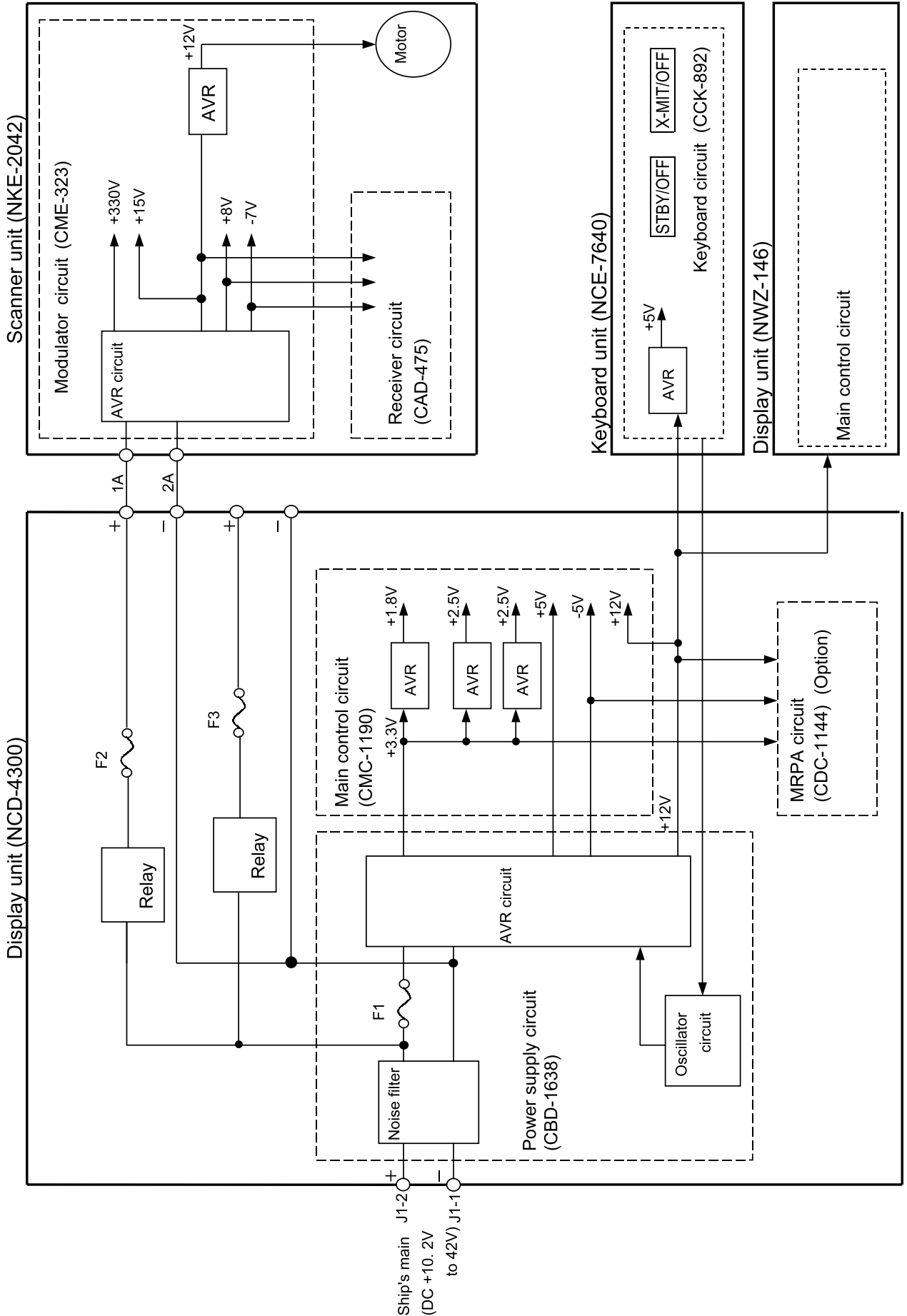

[Fig. 104. PRIMARY POWER SYSTEM DIAGRAM OF JMA-5104]

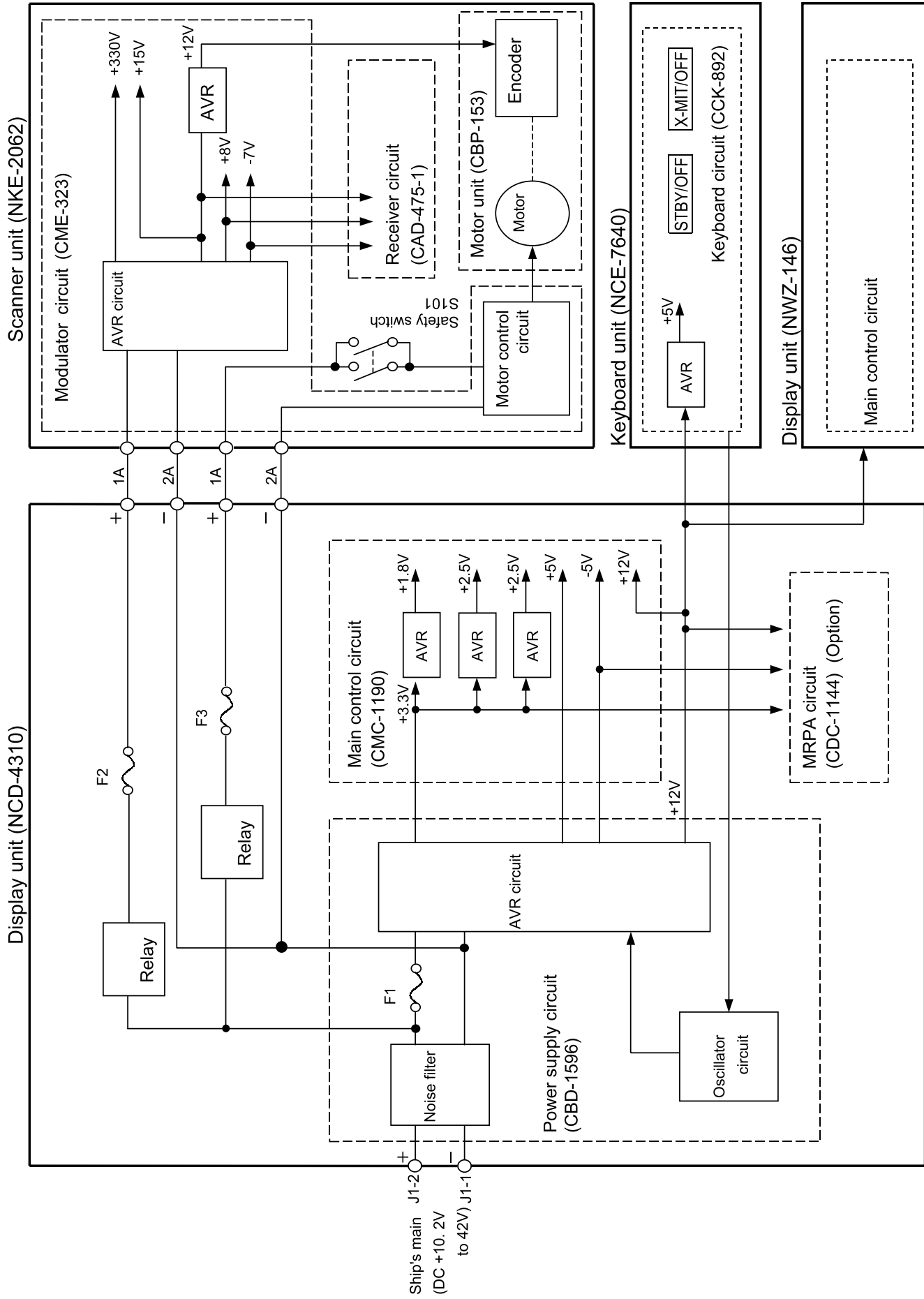

[Fig. 105 PRIMARY POWER SYSTEM DIAGRAM OF JMA-5106]

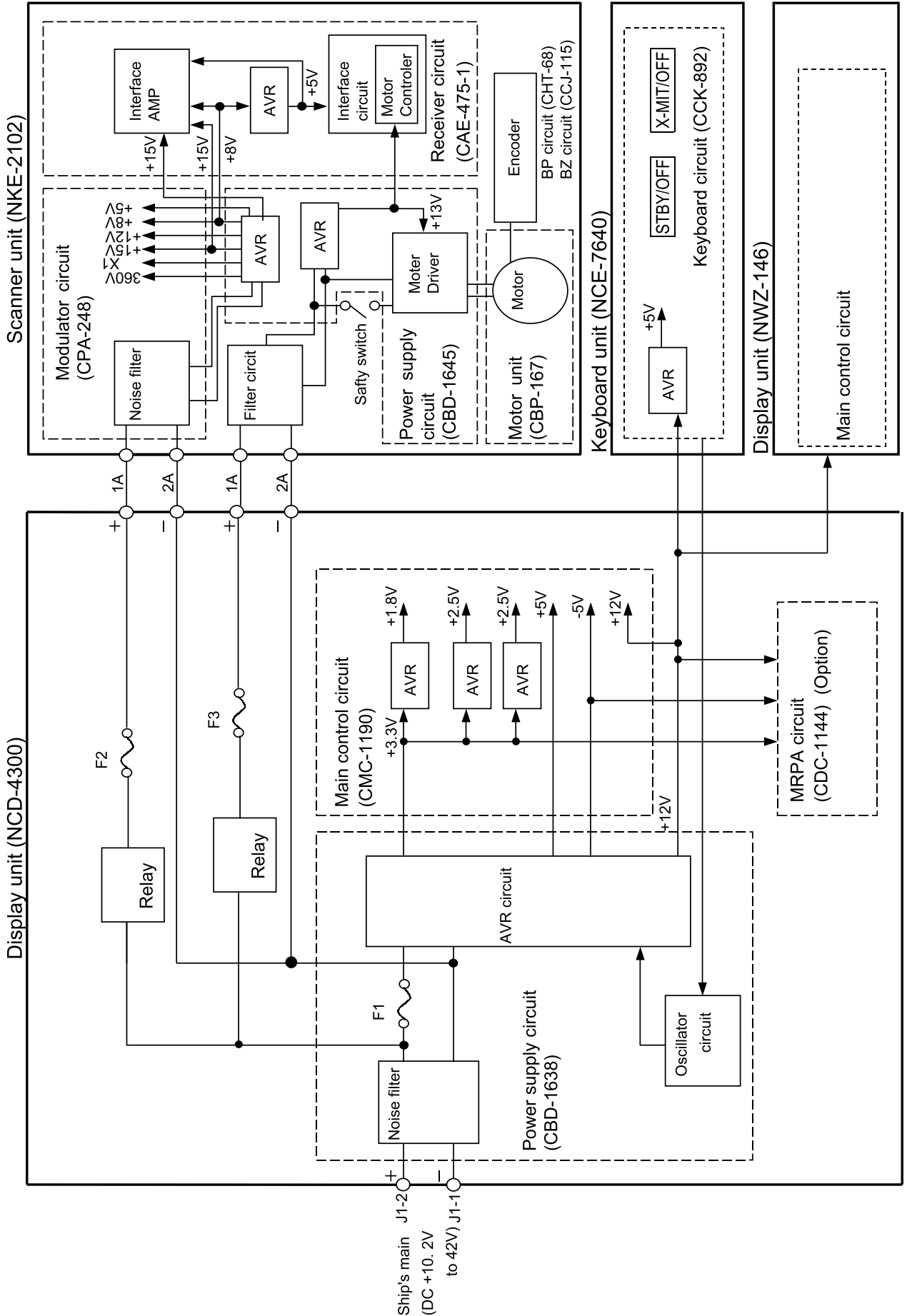

[Fig. 106 PRIMARY POWER SYSTEM DIAGRAM OF JMA-5110]

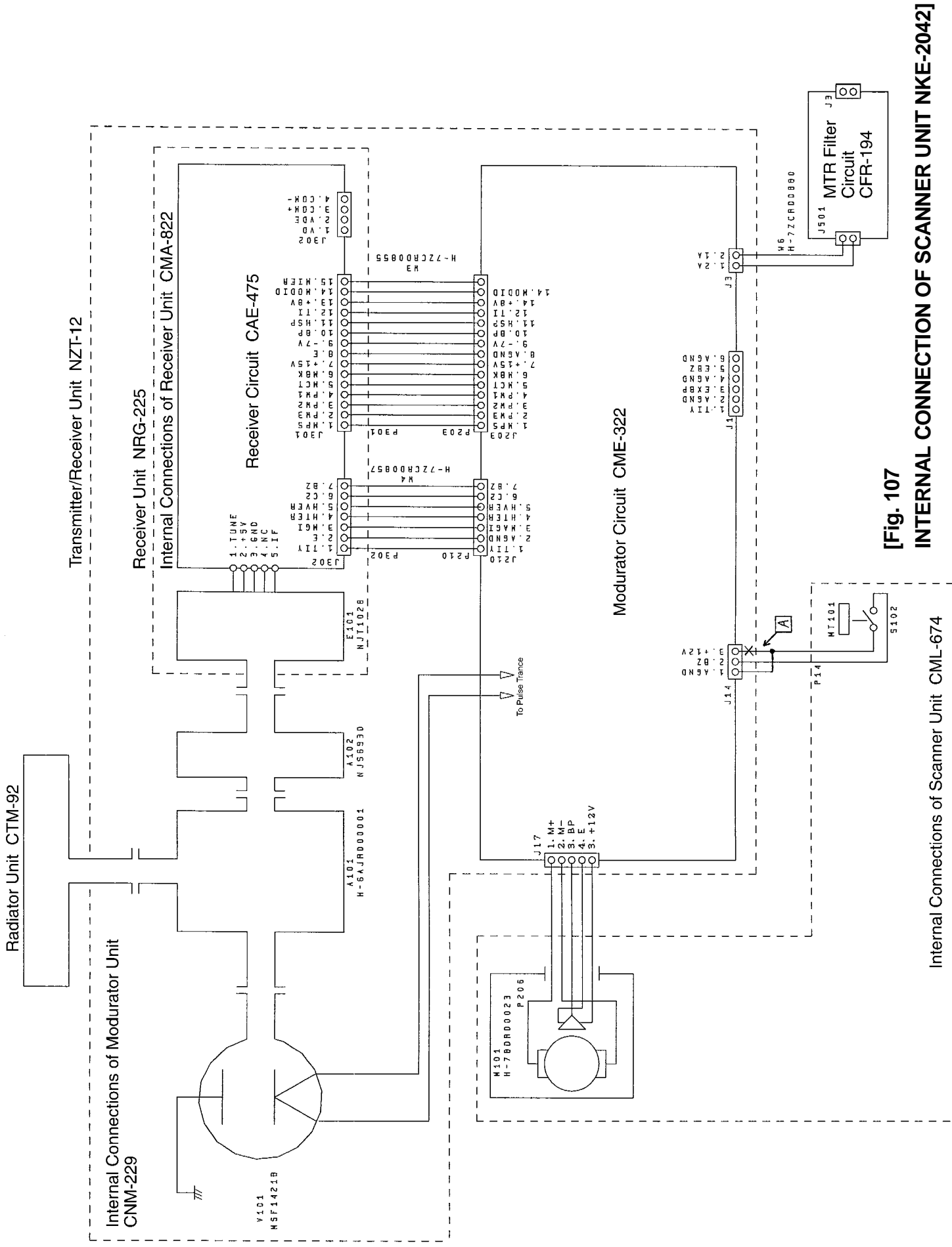

[Fig. 107

INTERNAL CONNECTION OF SCANNER UNIT NKE-2042]

Internal Connections of Scanner Unit CML-674

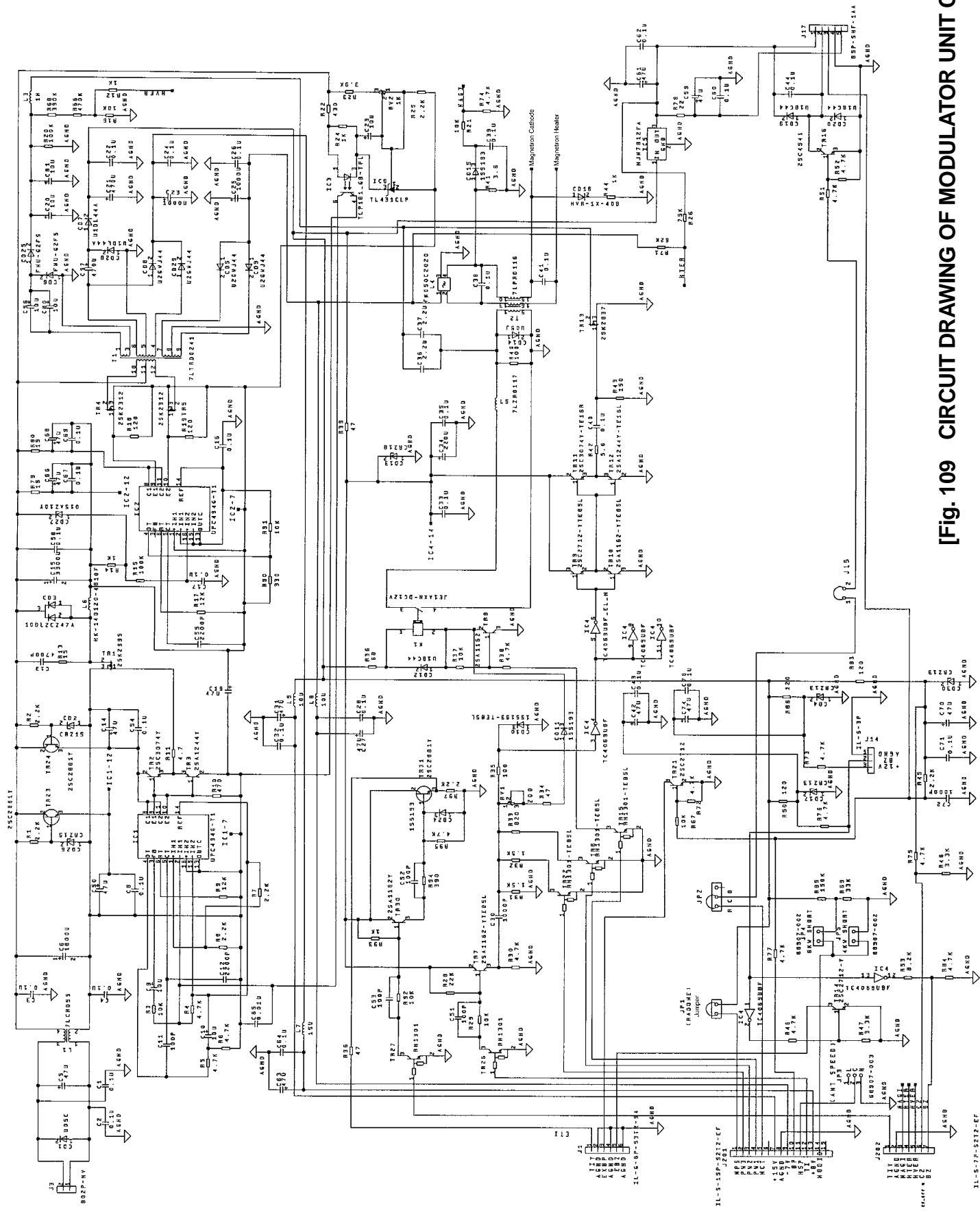

[Fig. 109 CIRCUIT DRAWING OF MODULATOR UNIT CME-322]

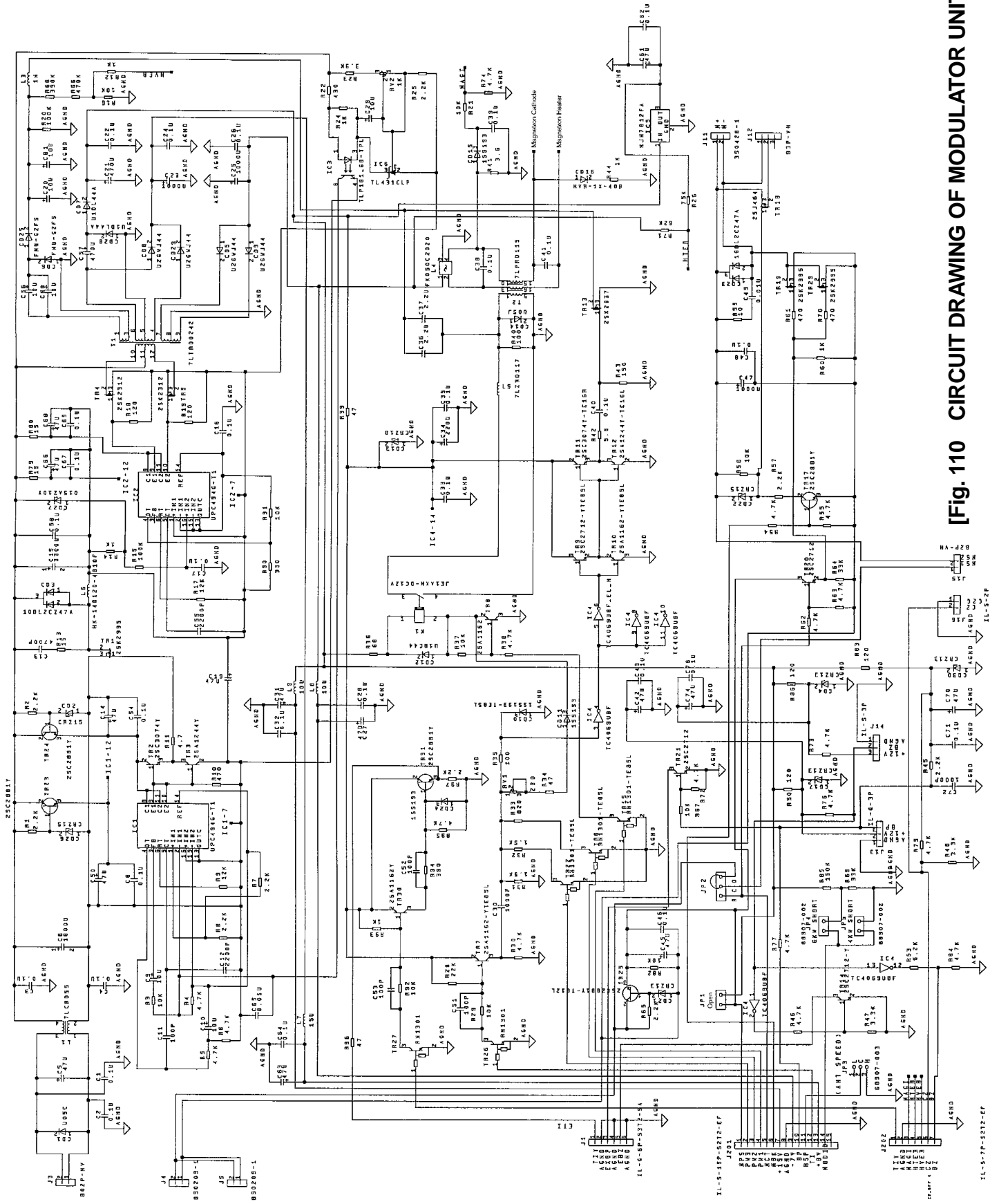

[Fig. 110 CIRCUIT DRAWING OF MODULATOR UNIT CME-323]

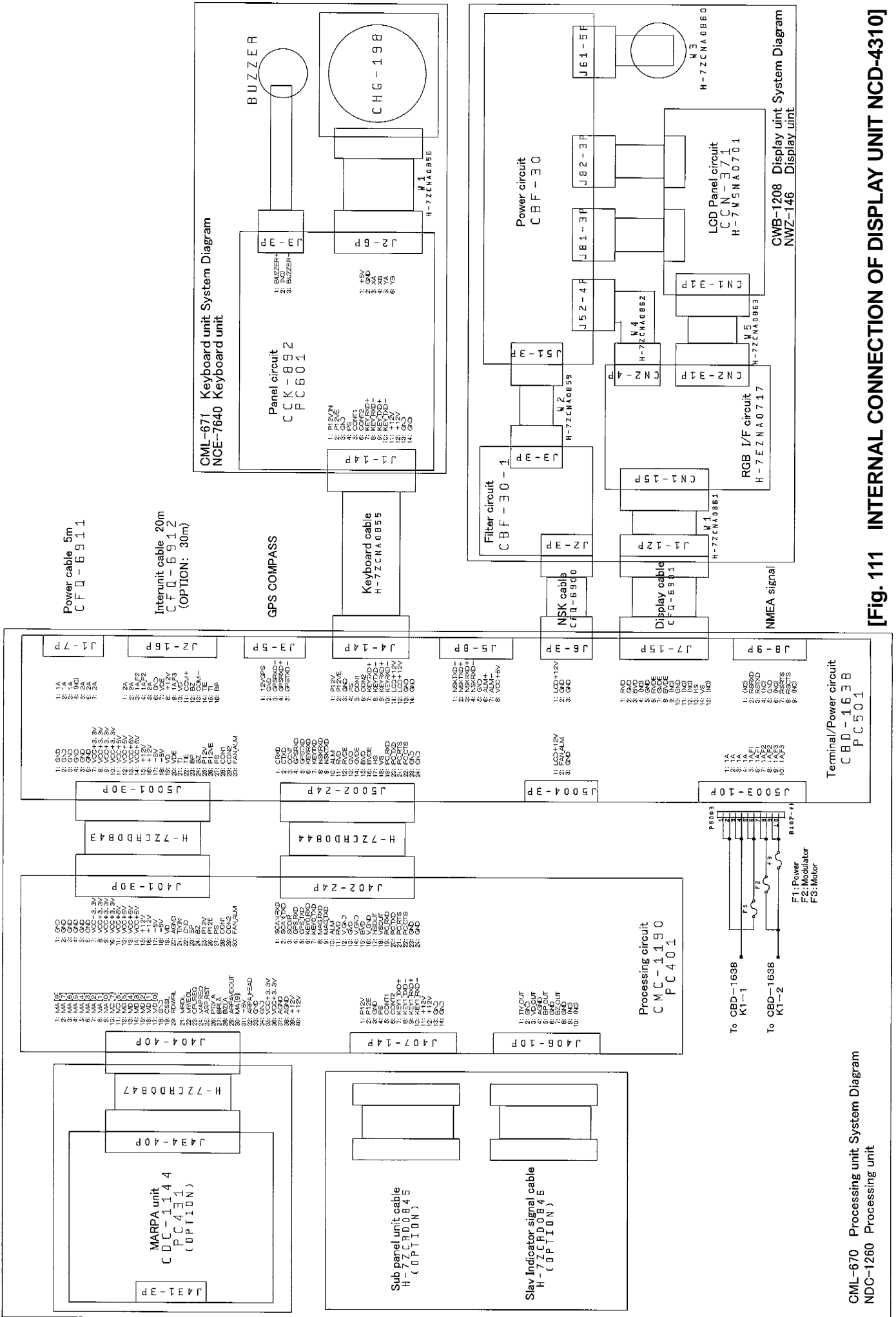

[Fig. 111 INTERNAL CONNECTION OF DISPLAY UNIT NCD-4310]

CML-670 Processing unit System Diagram
NDC-1260 Processing unit

CML-571 Keyboard unit System Diagram
NCE-7640 Keyboard unit

CWB-1208 Display unit System Diagram
NMZ-146 Display unit

Processing unit
C M C - 1 1 9 0
P C 4 0 1

Terminal/Power circuit
C B D - 1 6 3 8
P C 5 0 1

GPS COMPASS

Keyboard unit
C K K - 8 9 2
P C 6 0 1

BUZZER
C H G - 1 9 8

Filter circuit
C B F - 3 0 - 1

Power circuit
C B F - 3 0

LCD Panel circuit
C C N - 3 7 1
H - 7 M 5 N A 0 7 0 1

RGB I/F circuit
H - 7 E Z N A 0 7 1 7

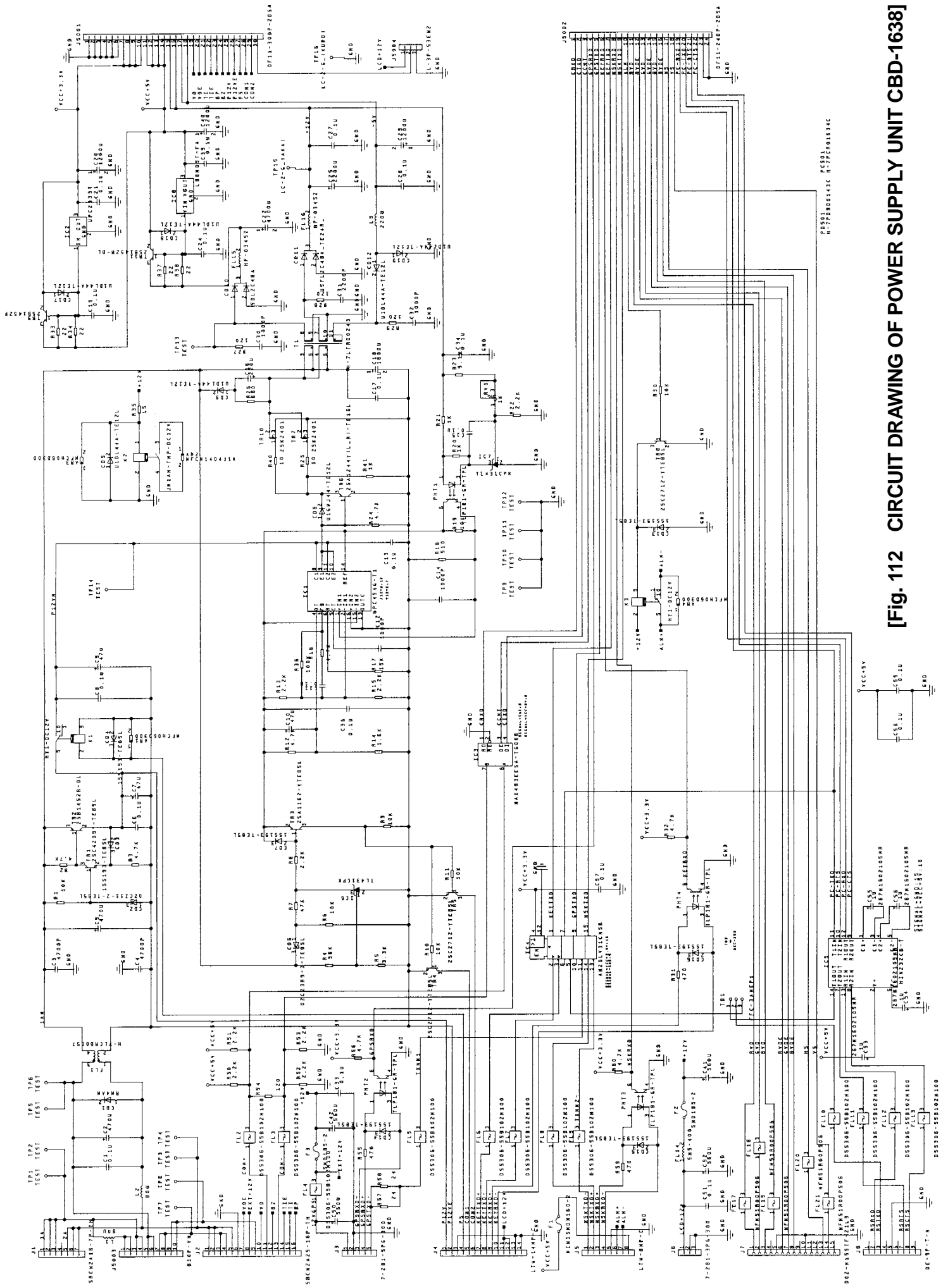

[Fig. 112 CIRCUIT DRAWING OF POWER SUPPLY UNIT CBD-1638]

CE 0191 ①

For further information contact:



Since 1915

Japan Radio Co., Ltd.

**HEAD OFFICE &
SALES DEPT.**

Nittochi Nishi-shinjuku bldg,
10-1, Nishi-Shinjuku 6-chome, Shinjuku-ku,
Tokyo 160-8328 JAPAN
Phone : +81-3-3348-0151
Fax : +81-3-3348-3648

MAIN PLANT

1-1, Shimorenjaku 5-chome, Mitaka-shi,
Tokyo 181-8510 JAPAN
Phone : +81-422-45-9111
Fax : +81-422-45-9110

CODE No. 7ZPRD0590

EDITION 1
JUN. 2003
JRC