

TEST DATA OF JMA-9122/9123

Type JMA-9122 Ser. No. LB00421

Scanner Unit NKE-1125

Display Unit NCD-4990

Ship's Main AC100 to 115V, 50/60Hz, 1 ϕ
 AC220 to 240V, 50/60Hz, 1 ϕ

Date July.17.2008

Section Chief Mr. Hashimoto

Inspector M. Itoh

1 Mechanical Tests

Appearance and Structure

Scanner Unit	Good
Display Unit	Good

2 Electrical Tests

2.1 Working of each operation unit

Scanner Unit	Good
Keyboard Unit	Good
POWER key	Good
PWR ACK key	Good
TX/STBY key	Good
EBL1/EBL2 key	Good
VRM1/VRM2 key	Good
ALARM ACK key	Good
ACQ MANUAL key	Good
ACQ CANCEL key	Good
TGT DATA key	Good
PANEL key	Good
USER key	Good
OPTION1/2 key	Good
T/R / VECT key	Good
DAY/NIGHT	Good
AIS/AR PA key	Good
HL OFF key	Good
DATA OFF key	Good
+/-RANGE key	Good
ACQ/ENT key	Good
TUNE Control	Good
RAIN Control	Good
SEA Control	Good
GAIN Control	Good
EBL dial	Good
VRM dial	Good
Track ball	Good
Track ballL/R button	Good

2.2 Scanner

VSWR	frequency (MHz)	VSWR
	9380	1.04
	9410	1.04
	9440	1.07
Scanner Rotation Speed		24 rpm

2.3 Transmitter

Magnetron Ser. No.	A0279A
Operating Frequency	
(at 0.07 μ s pulse 0.5 NM-SP1)	9418.3 MHz
(at 0.2 μ s pulse 3NM -MP1)	9415.8 MHz
(at 0.3 μ s pulse 3NM -MP2)	9414.7 MHz
(at 0.4 μ s pulse 3NM -MP3)	9414.7 MHz
(at 0.8 μ s pulse 3NM -LP1)	9414.2 MHz
(at 1.0 μ s pulse 24NM -LP2)	9413.7 MHz
(at 1.2 μ s pulse 24NM -LP3)	9413.7 MHz
Peak Output Power	
(at 0.07 μ s pulse 0.5 NM-SP1)	17.6 kw
(at 0.2 μ s pulse 3NM -MP1)	19.5 kw
(at 0.3 μ s pulse 3NM -MP2)	19.4 kw
(at 0.4 μ s pulse 3NM -MP3)	19.4 kw
(at 0.8 μ s pulse 3NM -LP1)	19.5 kw
(at 1.0 μ s pulse 24NM -LP2)	19.5 kw
(at 1.2 μ s pulse 24NM -LP3)	19.6 kw
Pulse Length	
(at 0.07 μ s pulse 0.5 NM-SP1)	0.086 μ S
(at 0.2 μ s pulse 3NM -MP1)	0.151 μ S
(at 0.3 μ s pulse 3NM -MP2)	0.260 μ S
(at 0.4 μ s pulse 3NM -MP3)	0.354 μ S
(at 0.8 μ s pulse 3NM -LP1)	0.740 μ S
(at 1.0 μ s pulse 24NM -LP2)	0.948 μ S
(at 1.2 μ s pulse 24NM -LP3)	1.110 μ S

2.4 Receiver

MIC Front-end Ser. No.	0001
Diode limiter Ser. No.	A8939A
IF Center Frequency	60 MHz
IF Bandwidth	20/6/3 MHz

2.5 Display

Input Voltage and Current(at 48NM)	AC.100V 4.2A
Repetition Frequency	
(0.07 μ s)	2249 Hz
(0.2 μ s)	2249 Hz
(0.3 μ s)	1901 Hz
(0.4 μ s)	1401 Hz
(0.8 μ s)	750 Hz
(1.0 μ s)	650 Hz
(1.2 μ s)	510 Hz

3 Overall Tests

Working Time of Timer	3min
Input Variation (AC 90 V – 126.5 V)	Good
Overall Sensitivity	Good
Minimum Range	Good
Bearing Accuracy	Good
Mechanical Noise	Good

(Sec. 2.1046) 1.0 RF Power Output

(Sec. 2.1049) 2.0 Occupied Bandwidth

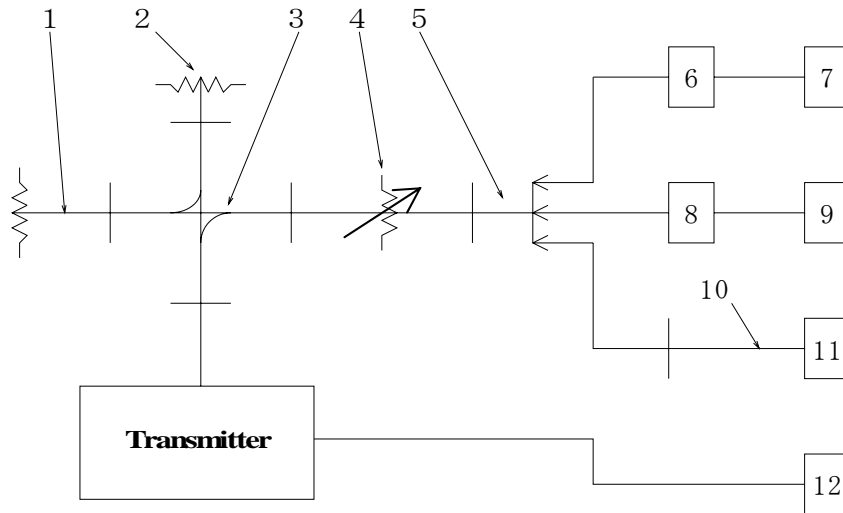

1:Dummy Load	PE6815	PASTERNAK
2:High Power Dummy Load	PE6824	PASTERNAK
3:Direction Coupler	5D363	SHIMADARIKA
Coupling 30dB		
Directivity 30dB		
4:Attenuator	8495B	HP
5:Adaptor	X281A	HP
6:Power Sensor	N1921A	Agilent
7:Power Meter	N1911A	Agilent
8:Crystal Detector	423B	HP
9:Oscilloscope	TDS3034B	Tektronix
10:Coaxial Cable	JUNFLON DGM024	JUNKOSHA
11:Spectrum Analyzer	E4448A	Agilent
12:Frequency Counter	5302A	HP

Measurement Point : Transmitter Output

FCC Submittal Material Data

(Sec. 2.1046)

1.0 RF Power Output

1.1 Peak Power

(at 0.07 μ s pulse 0.5 NM-SP1)	17.6 kw
(at 0.2 μ s pulse 3NM -MP1)	19.5 kw
(at 0.3 μ s pulse 3NM -MP2)	19.4 kw
(at 0.4 μ s pulse 3NM -MP3)	19.4 kw
(at 0.8 μ s pulse 3NM -LP1)	19.5 kw
(at 1.0 μ s pulse 24NM -LP2)	19.5 kw
(at 1.2 μ s pulse 24NM -LP3)	19.6 kw

1.2 Average Power

(at 0.07 μ s pulse 0.5 NM-SP1)	3.49 w
(at 0.2 μ s pulse 3NM -MP1)	6.62 w
(at 0.3 μ s pulse 3NM -MP2)	9.59 w
(at 0.4 μ s pulse 3NM -MP3)	9.62 w
(at 0.8 μ s pulse 3NM -LP1)	10.8 w
(at 1.0 μ s pulse 24NM -LP2)	12.0 w
(at 1.2 μ s pulse 24NM -LP3)	11.1 w

1.3 Load Impedance

VSWR 1.05 at 9.36 – 9.46 GHz

(Sec. 2.1049) 2.0 Occupied Bandwidth
 2.1 0.07 μ S Pulse PRF 2249Hz
 0.07 μ S Pulse Length 0.0856 μ S

Scale
 10dB/Div

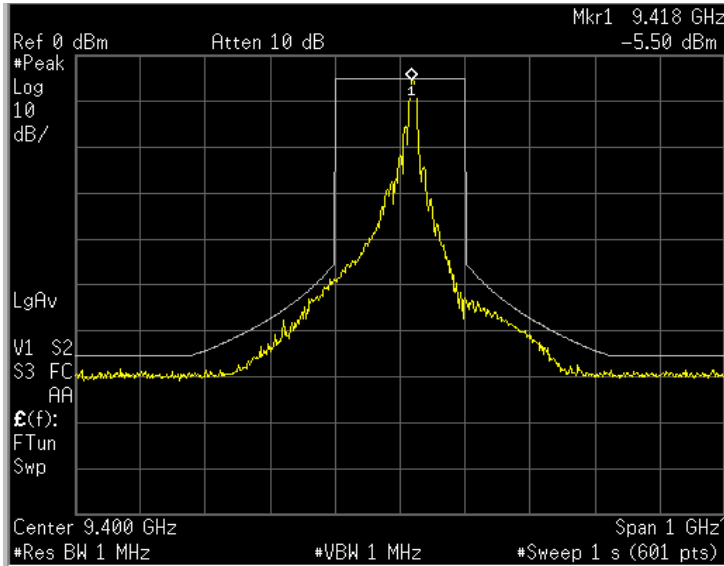

RF Spectrum
 0.07 μ S Pulse

OBW=54.3 MHz

Scale 100MHz/Div
 Center Frequency 9400MHz

Scale
 50mV/Div

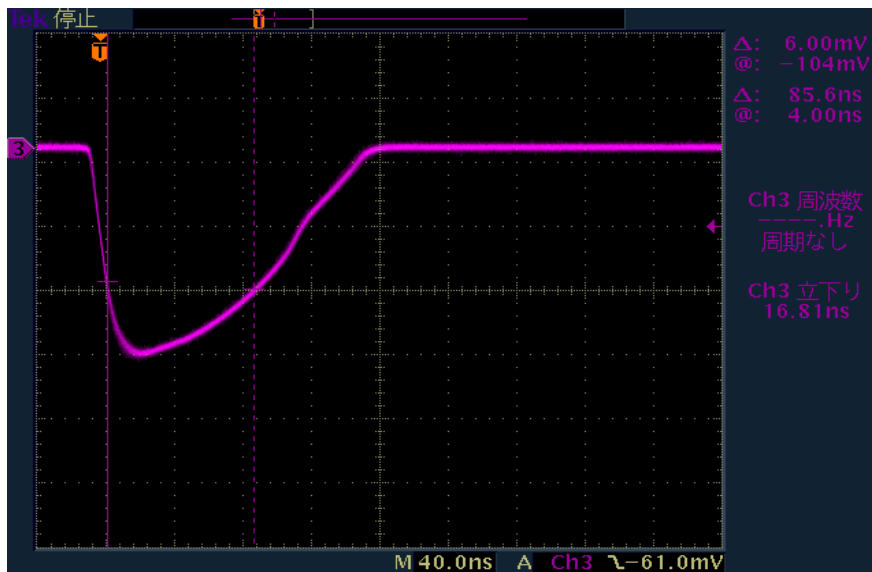

← - 3 dB

Detected RF
 Pulse
 0.07 μ S Pulse

Scale 0.04 μ S/Div

(Sec. 2.1049)

2.2 0.2 μ S Pulse PRF 2249Hz
0.2 μ S Pulse Length 0.151 μ S

Scale
10dB/Div

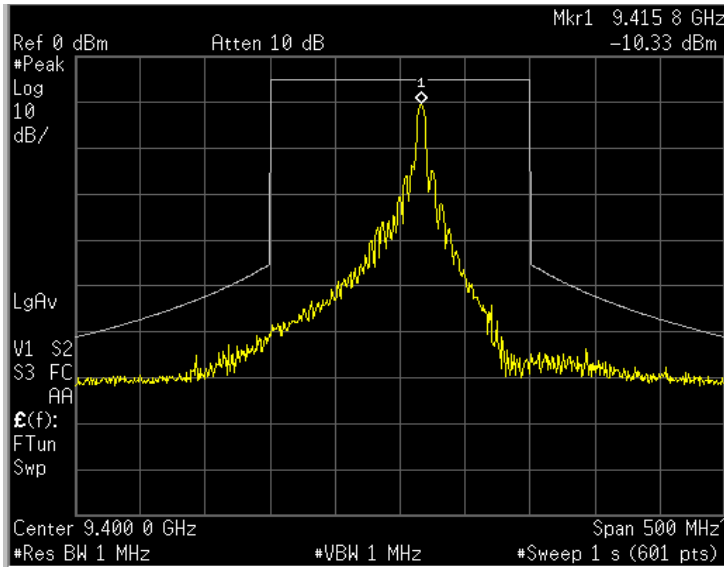

RF Spectrum
0.2 μ S Pulse

OBW=41.1MHz

Scale 50MHz/Div
Center Frequency 9400MHz

Scale
50mV/Div

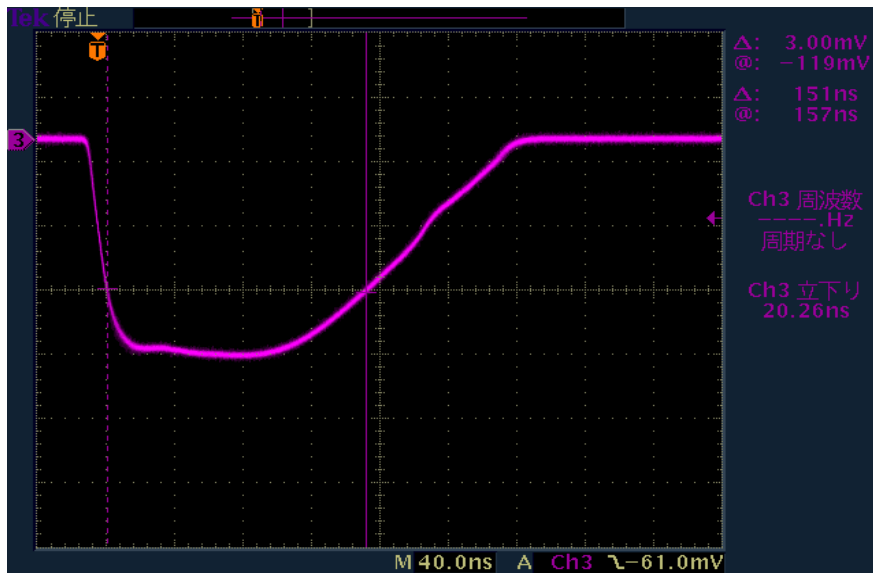

← - 3 dB

Detected RF
Pulse
0.2 μ S Pulse

Scale 0.04 μ S/Div

(Sec. 2.1049)

2.3 0.3 μ S Pulse PRF 1901Hz
0.3 μ S Pulse Length 0.26 μ S

Scale
10dB/Div

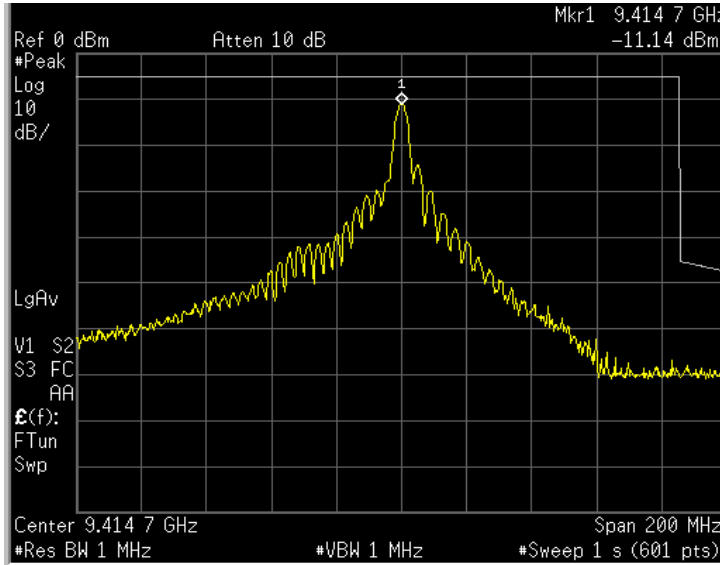

RF Spectrum
0.3 μ S Pulse

OBW=29.7MHz

Scale 20MHz/Div
Center Frequency 9414.7MHz

Scale
50mV/Div

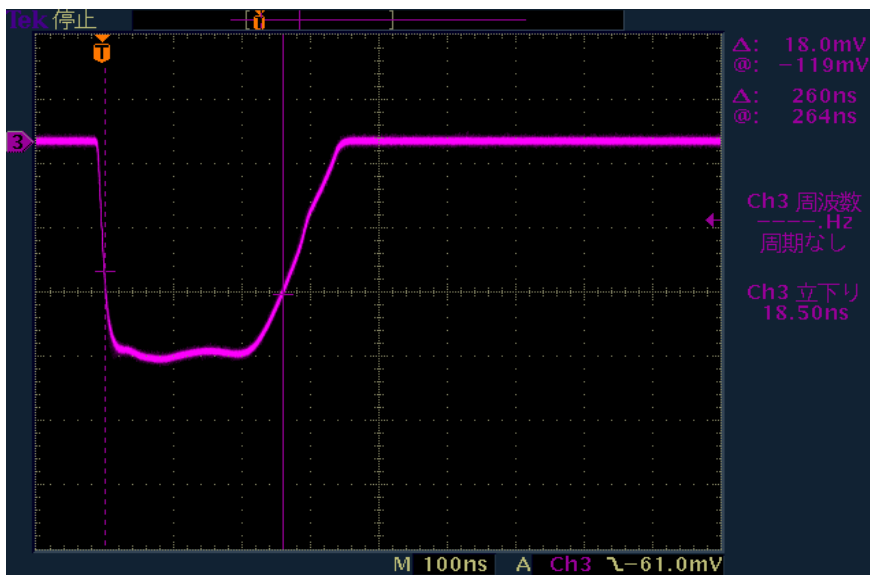

\leftarrow -3 dB

Detected RF
Pulse
0.3 μ S Pulse

Scale 0.1 μ S/Div

(Sec. 2.1049)

2.4 0.4 μ S Pulse PRF 1401Hz
0.4 μ S Pulse Length 0.354 μ S

Scale
10dB/Div

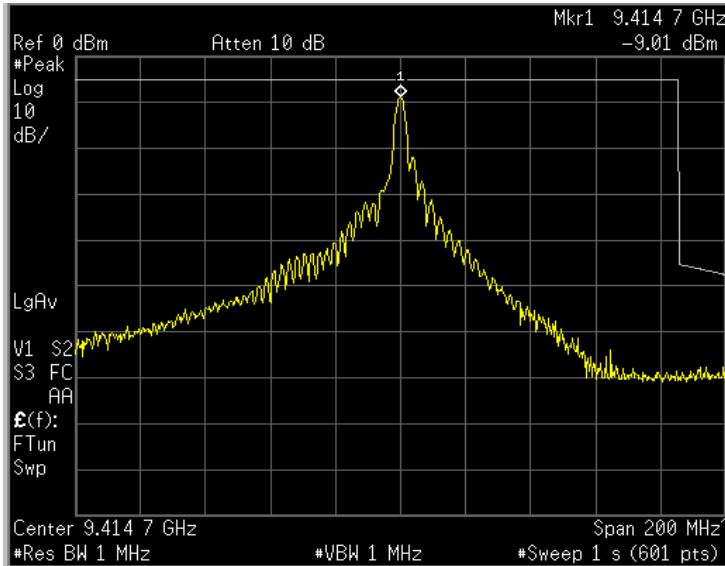

RF Spectrum
0.4 μ S Pulse

OBW=24.0MHz

Scale 20MHz/Div
Center Frequency 9414.7MHz

Scale
50mV/Div

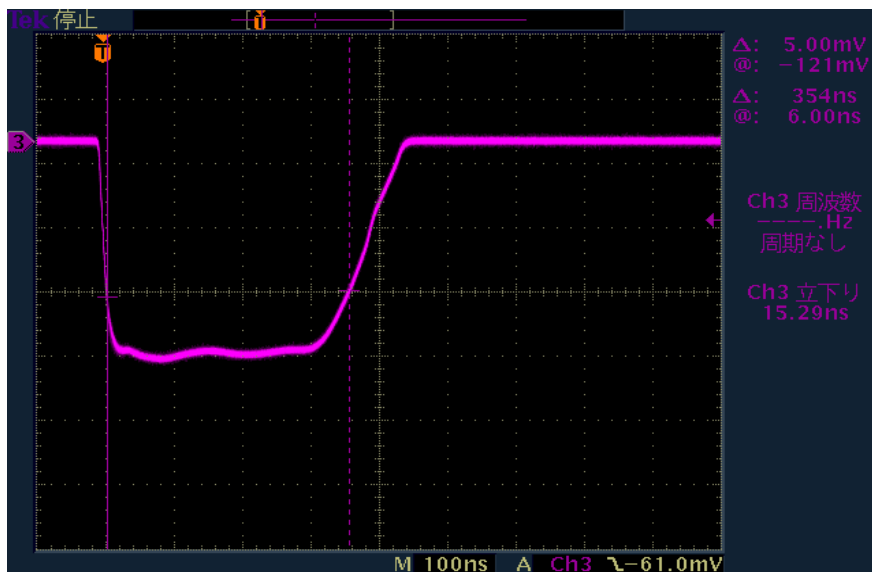

← - 3 dB

Detected RF
Pulse
0.4 μ S Pulse

Scale 0.1 μ S/Div

(Sec. 2.1049)

2.5 0.8 μ S Pulse PRF 749.8Hz
0.8 μ S Pulse Length 0.740 μ S

Scale
10dB/Div

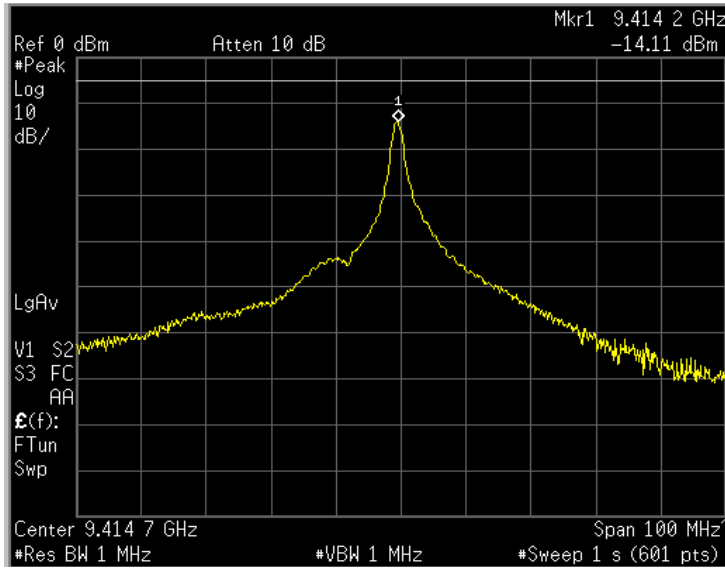

RF Spectrum
0.8 μ S Pulse
OBW=13.9MHz

Scale 10MHz/Div
Center Frequency 9414.7MHz

Scale
50mV/Div

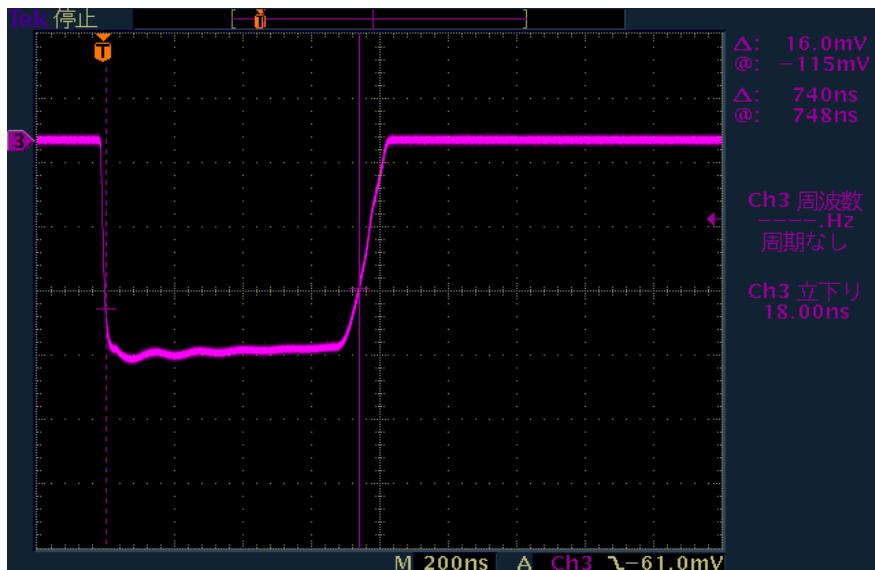

← - 3 dB
Detected RF
Pulse
0.8 μ S Pulse

Scale 0.2 μ S/Div

(Sec. 2.1049)

2.5 1.0 μ S Pulse PRF 650.2Hz
1.0 μ S Pulse Length 1.11 μ S

Scale
10dB/Div

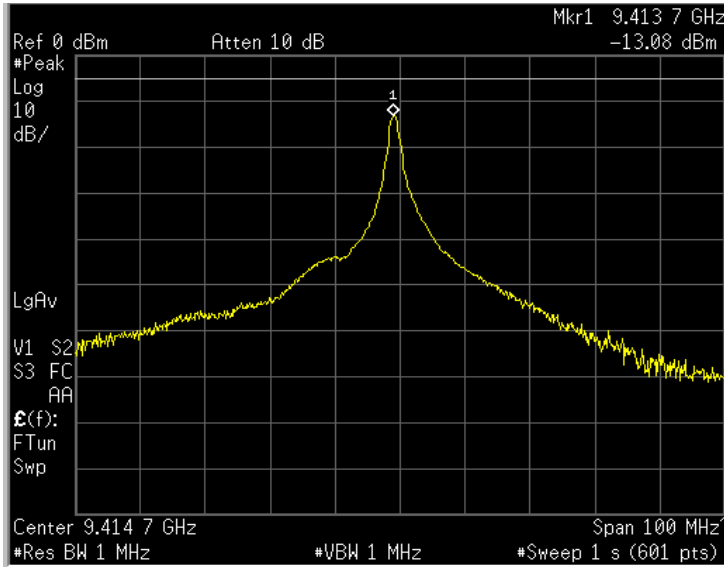

RF Spectrum
1.0 μ S Pulse

OBW=12.2MHz

Scale 10MHz/Div
Center Frequency 9414.7MHz

Scale
50mV/Div

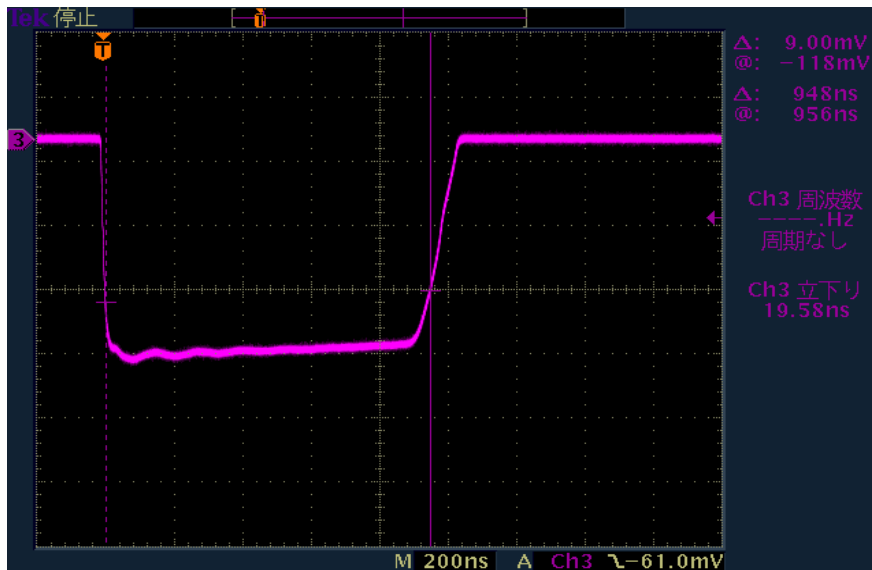

← -3 dB

Detected RF
Pulse
1.0 μ S Pulse

Scale 0.2 μ S/Div

(Sec. 2.1049)

2.5 1.2 μ S Pulse PRF 509.9Hz
1.2 μ S Pulse Length 1.11 μ S

Scale
10dB/Div

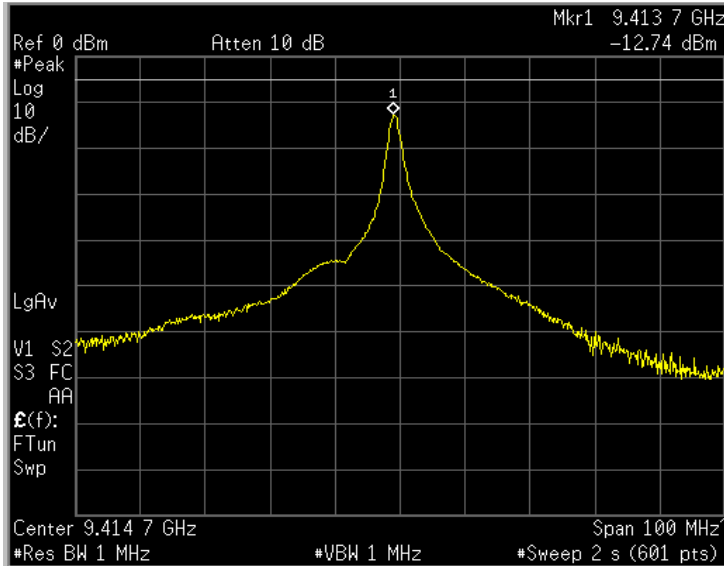

RF Spectrum
1.2 μ S Pulse

OBW=11.1MHz

Scale 10MHz/Div
Center Frequency 9414.7MHz

Scale
50mV/Div

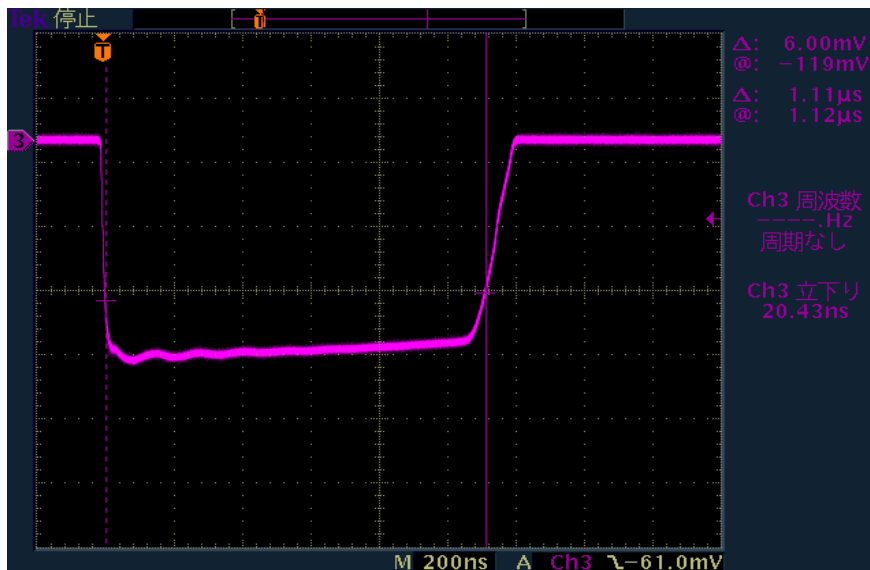

← - 3 dB

Detected RF
Pulse
1.2 μ S Pulse

Scale 0.2 μ S/Div

(Sec.2.1051) Spurious emission at antenna terminals

Condition 1: 0 to 20GHz

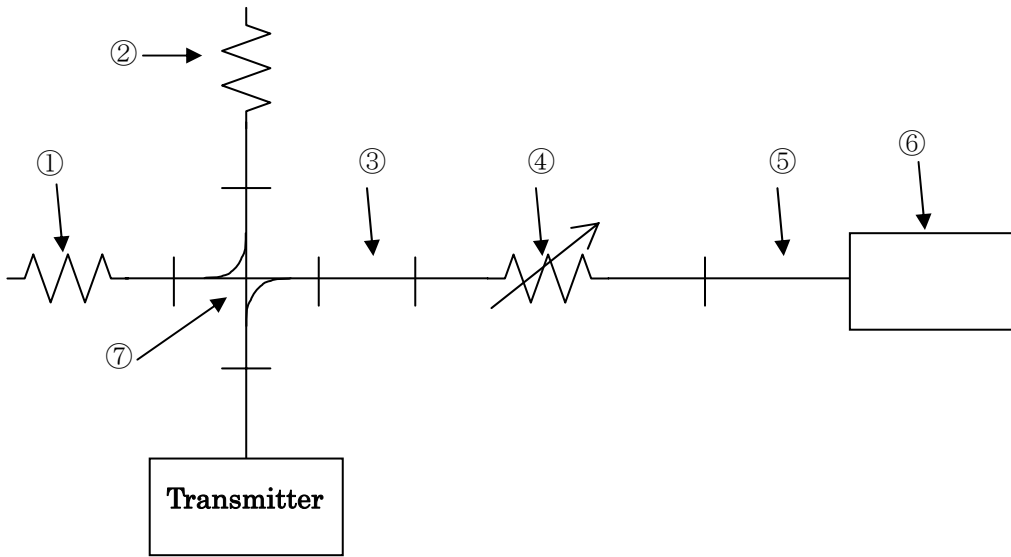

①Dummy Load	PE6815	PASTERNAK
②High Power Dummy Load	PE6824	PASTERNAK
③Adaptor	X281A	HP
④Attenuator	8495B	HP
⑤Coaxial Cable	JUNFLON DGM024	JUNKOSHA
⑥Spectrum Analyzer	E4448A	Agilent
⑦Direction Coupler	5D363	SHIMADARIKA
Coupling	: 30dB	
Directivity	: 30dB	

Attenuation 4 : 40dB
 Measurement Point : Transmitter Output

(2.1051)

Scale
↑ 10dB/Div
→ 290MHz/Div

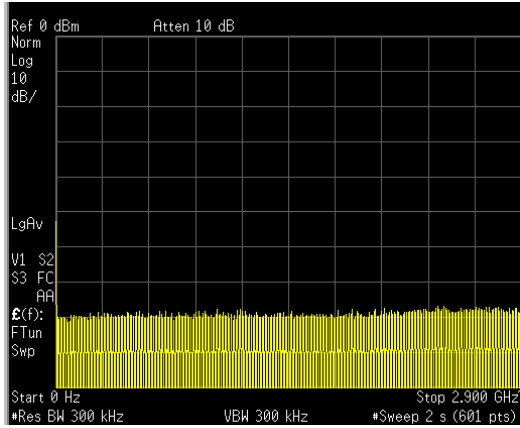

Spurious signal

OFF

0 to 2.9GHz

Scale
↑ 10dB/Div
→ 290MHz/Div

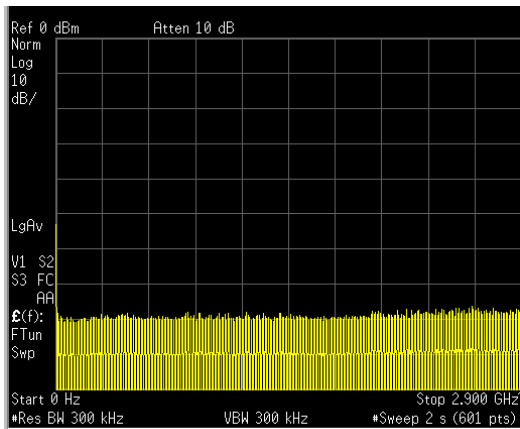

Spurious signal

Stand-By

0 to 2.9GHz

Scale
↑ 10dB/Div
→ 290MHz/Div

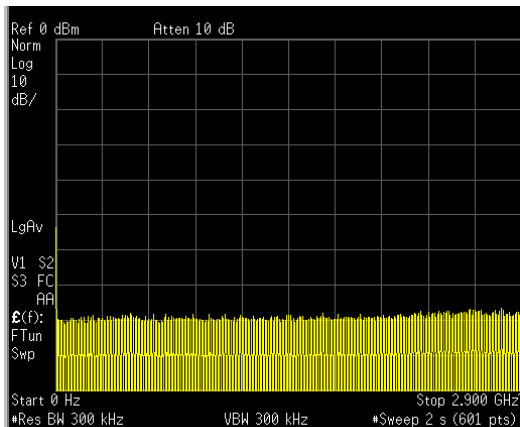

Spurious signal

0.070 μ s Pulse

0 to 2.9GHz

(2.1051)

Scale
↑ 10dB/Div
→ 290MHz/Div

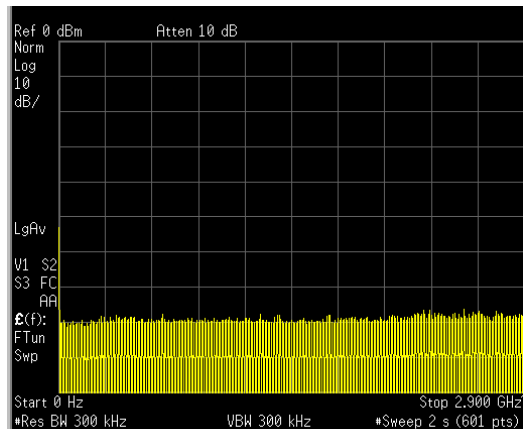

Spurious signal
0.20 μ s Pulse
0 to 2.9GHz

Scale
↑ 10dB/Div
→ 290MHz/Div

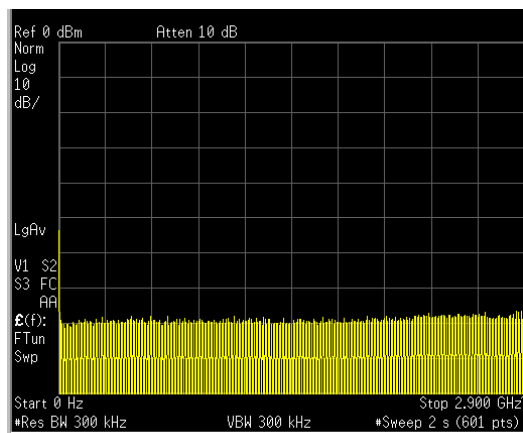

Spurious signal
0.30 μ s Pulse
0 to 2.9GHz

Scale
↑ 10dB/Div
→ 290MHz/Div

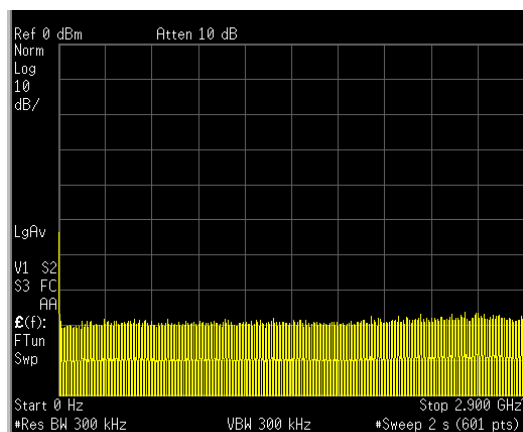

Spurious signal
0.40 μ s Pulse
0 to 2.9GHz

(2.1051)

Scale

↑ 10dB/Div

→ 290MHz/Div

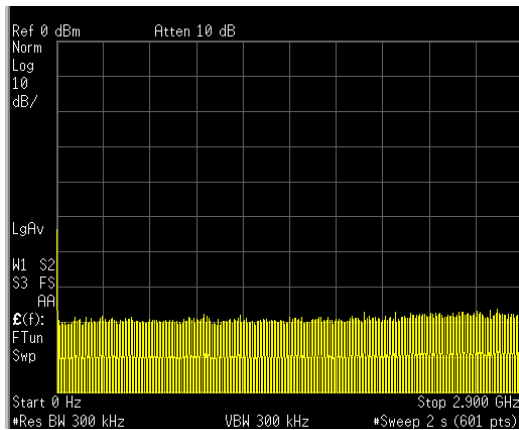

Spurious signal

0.80 μ s Pulse

0 to 2.9GHz

Scale

↑ 10dB/Div

→ 290MHz/Div

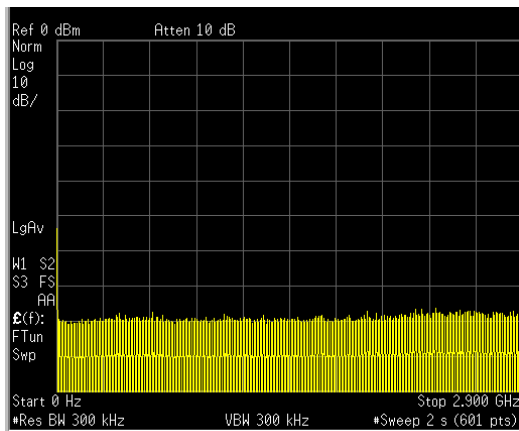

Spurious signal

1.0 μ s Pulse

0 to 2.9GHz

Scale

↑ 10dB/Div

→ 290MHz/Div

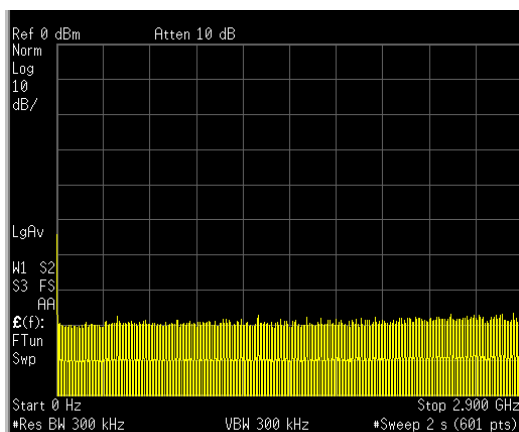

Spurious signal

1.2 μ s Pulse

0 to 2.9GHz

(2.1051)

Scale
↑ 10dB/Div
→ 350MHz/Div

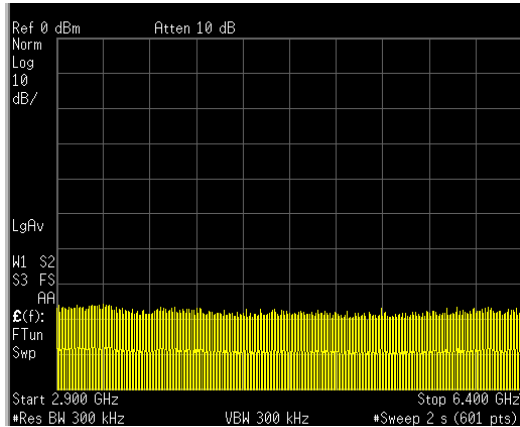

Spurious signal

OFF

2.9 to 6.4GHz

Scale
↑ 10dB/Div
→ 350MHz/Div

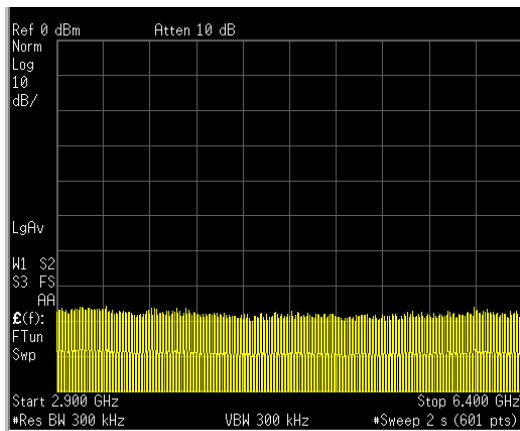

Spurious signal

Stand-By

2.9 to 6.4GHz

Scale
↑ 10dB/Div
→ 350MHz/Div

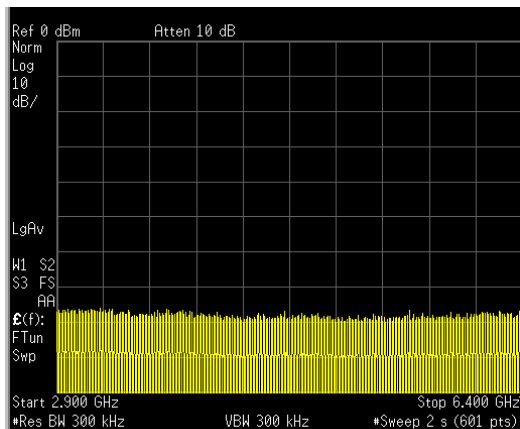

Spurious signal

0.070 μ s Pulse

2.9 to 6.4GHz

(2.1051)

Scale

↑ 10dB/Div

→ 350MHz/Div

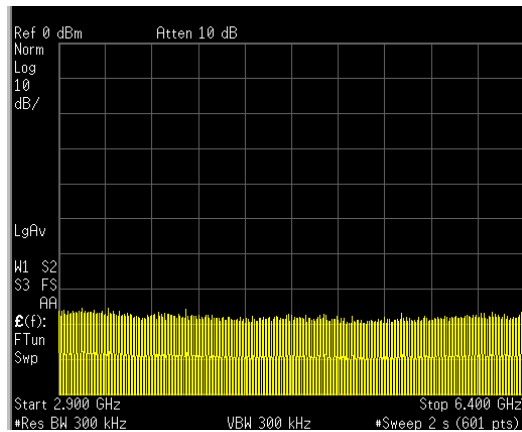

Spurious signal

0.20 μ s Pulse

2.9 to 6.4GHz

Scale

↑ 10dB/Div

→ 350MHz/Div

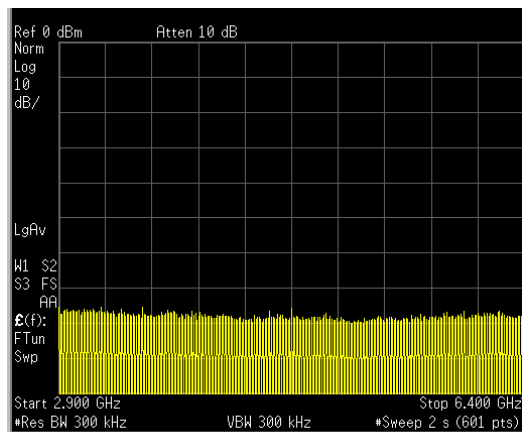

Spurious signal

0.30 μ s Pulse

2.9 to 6.4GHz

Scale

↑ 10dB/Div

→ 350MHz/Div

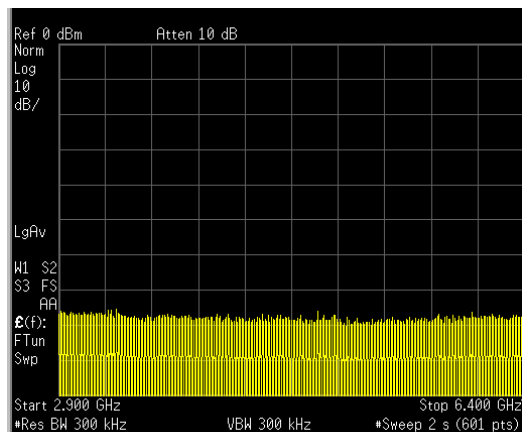

Spurious signal

0.40 μ s Pulse

2.9 to 6.4GHz

(2.1051)

Scale
↑ 10dB/Div
→ 350MHz/Div

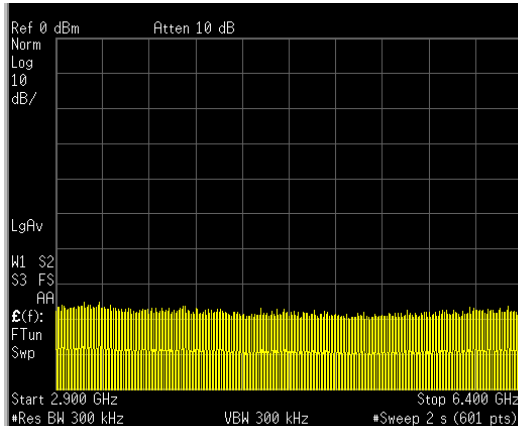

Spurious signal

0.80 μ s Pulse

2.9 to 6.4GHz

Scale
↑ 10dB/Div
→ 350MHz/Div

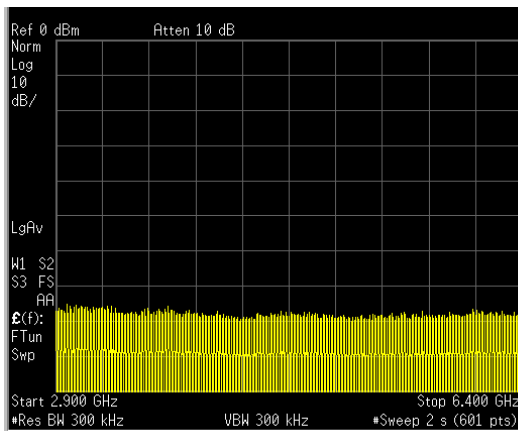

Spurious signal

1.0 μ s Pulse

2.9 to 6.4GHz

Scale
↑ 10dB/Div
→ 350MHz/Div

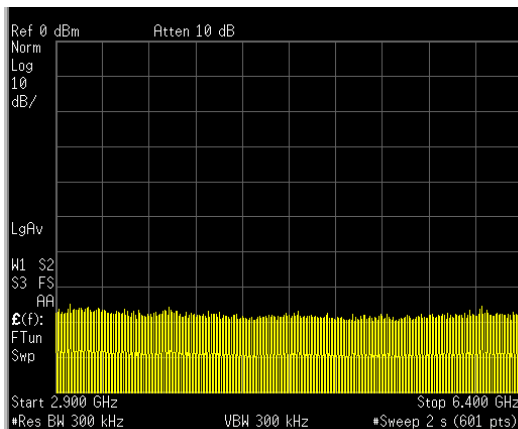

Spurious signal

1.2 μ s Pulse

2.9 to 6.4GHz

(2.1051)

Scale
↑ 10dB/Div
→ 660MHz/Div

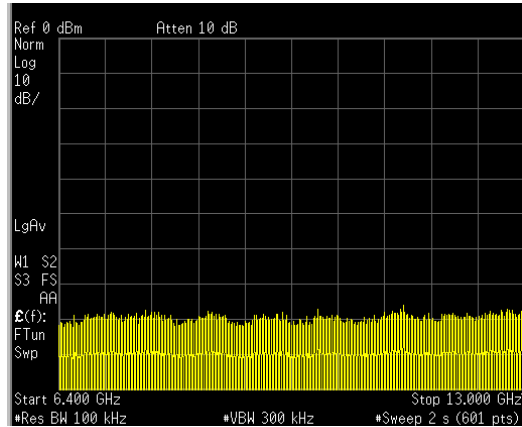

Spurious signal

OFF

6.4 to 13GHz

Scale
↑ 10dB/Div
→ 660MHz/Div

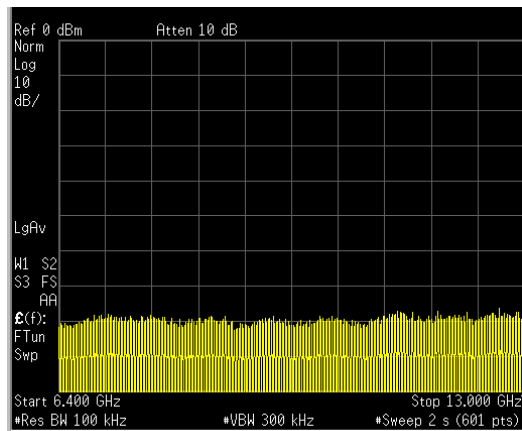

Spurious signal

Stand-By

6.4 to 13GHz

Scale
↑ 10dB/Div
→ 660MHz/Div

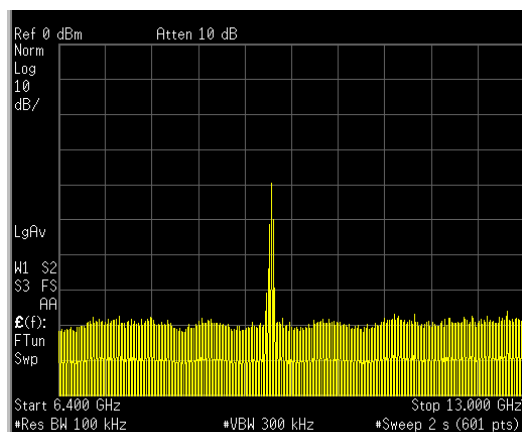

Spurious signal

0.070 μ s Pulse

6.4 to 13GHz

(2.1051)

Scale
↑ 10dB/Div
→ 660MHz/Div

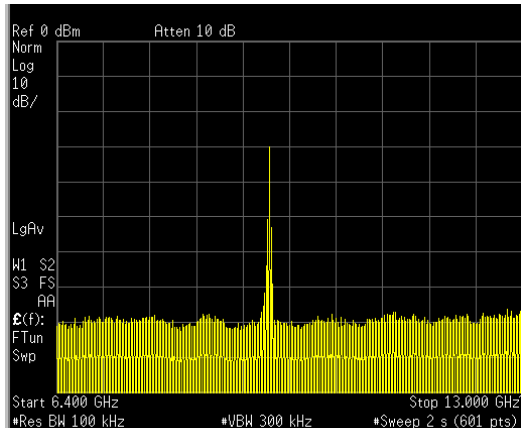

Spurious signal

0.20 μ s Pulse

6.4 to 13GHz

Scale
↑ 10dB/Div
→ 660MHz/Div

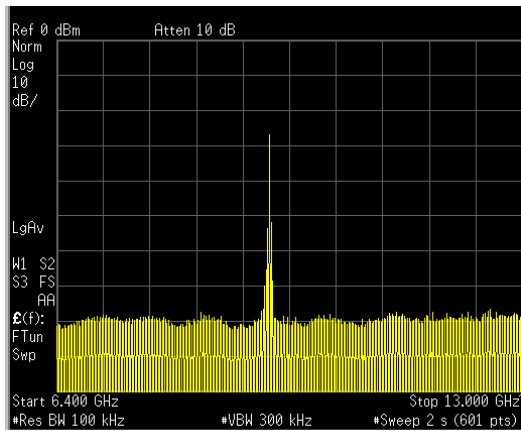

Spurious signal

0.30 μ s Pulse

6.4 to 13GHz

Scale
↑ 10dB/Div
→ 660MHz/Div

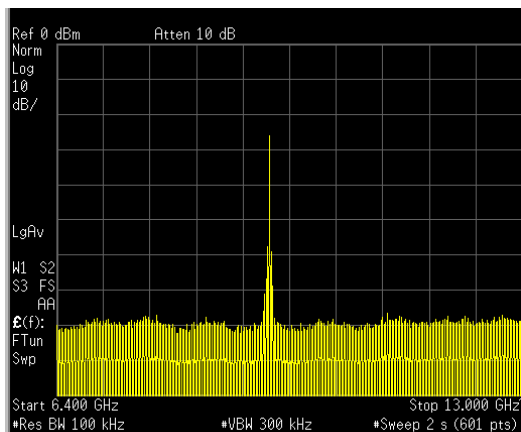

Spurious signal

0.40 μ s Pulse

6.4 to 13GHz

(2.1051)

Scale

↑ 10dB/Div

→ 660MHz/Div

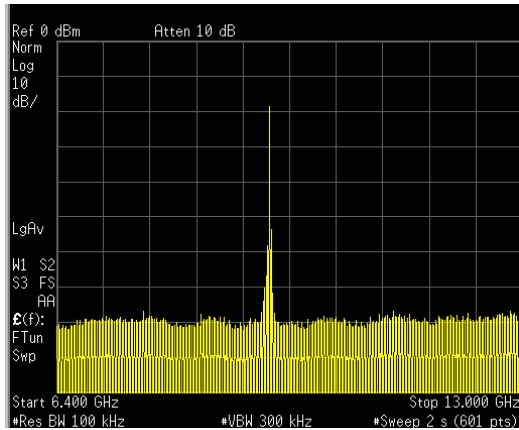

Spurious signal

0.80 μ s Pulse

6.4 to 13GHz

Scale

↑ 10dB/Div

→ 660MHz/Div

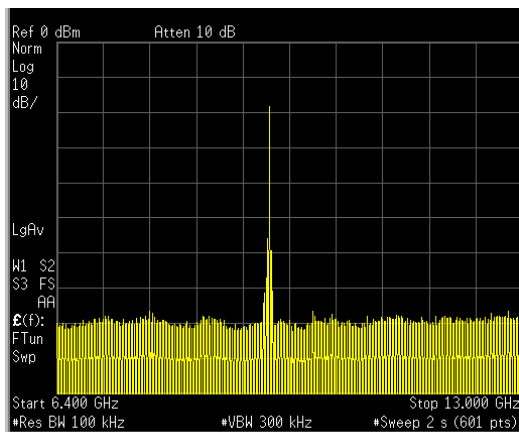

Spurious signal

1.0 μ s Pulse

6.4 to 13GHz

Scale

↑ 10dB/Div

→ 660MHz/Div

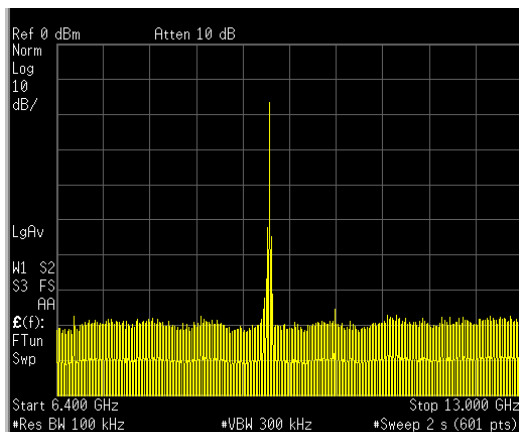

Spurious signal

1.2 μ s Pulse

6.4 to 13GHz

(2.1051)

Scale
↑ 10dB/Div
→ 700MHz/Div

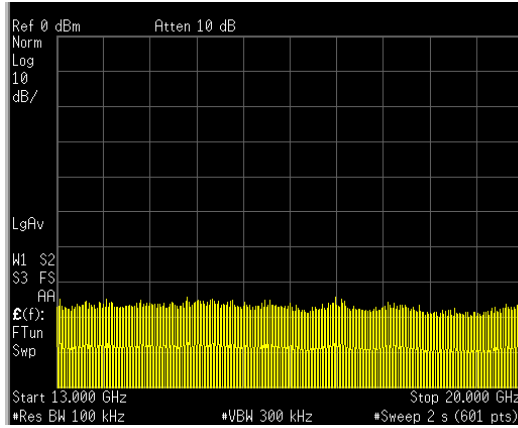

Spurious signal

OFF

13 to 20GHz

Scale
↑ 10dB/Div
→ 700MHz/Div

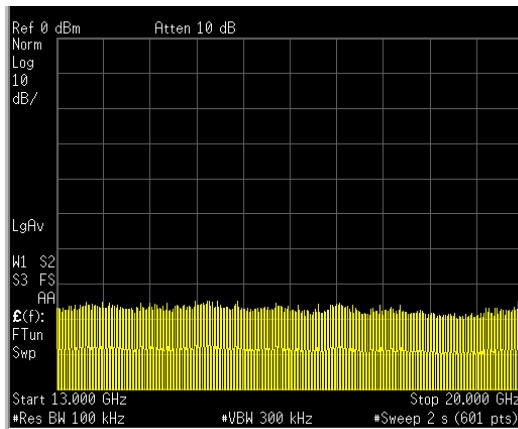

Spurious signal

Stand-By

13 to 20GHz

Scale
↑ 10dB/Div
→ 700MHz/Div

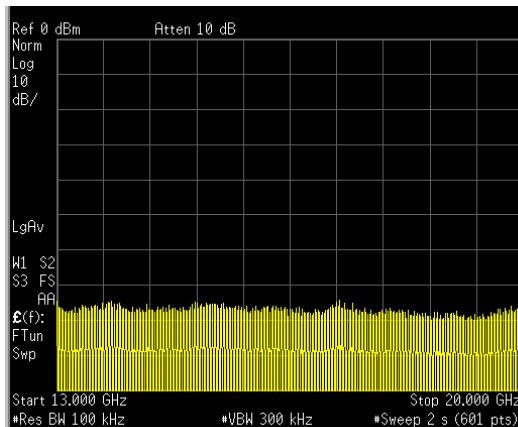

Spurious signal

0.070 μ s Pulse

13 to 20GHz

(2.1051)

Scale
↑ 10dB/Div
→ 700MHz/Div

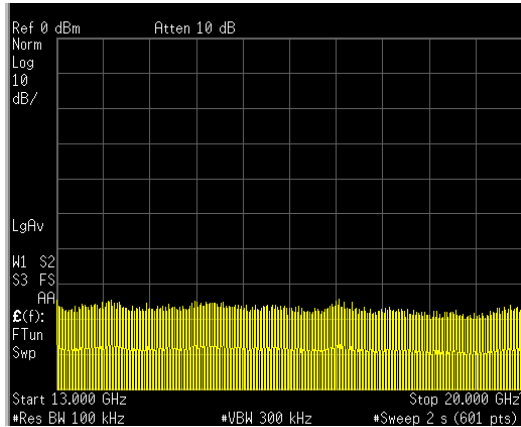

Spurious signal

0.20 μ s Pulse

13 to 20GHz

Scale
↑ 10dB/Div
→ 700MHz/Div

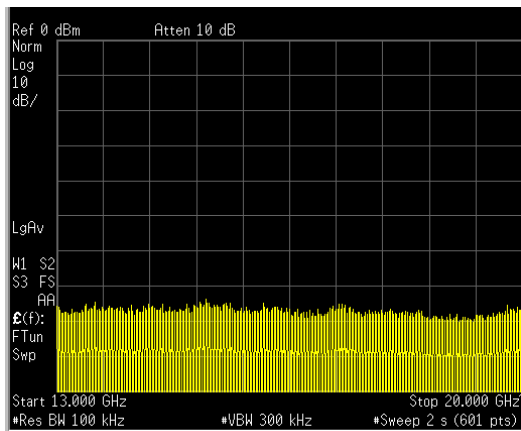

Spurious signal

0.30 μ s Pulse

13 to 20GHz

Scale
↑ 10dB/Div
→ 700MHz/Div

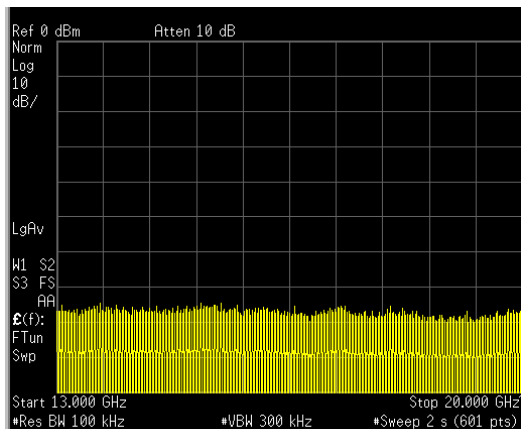

Spurious signal

0.40 μ s Pulse

13 to 20GHz

(2.1051)

Scale
↑ 10dB/Div
→ 700MHz/Div

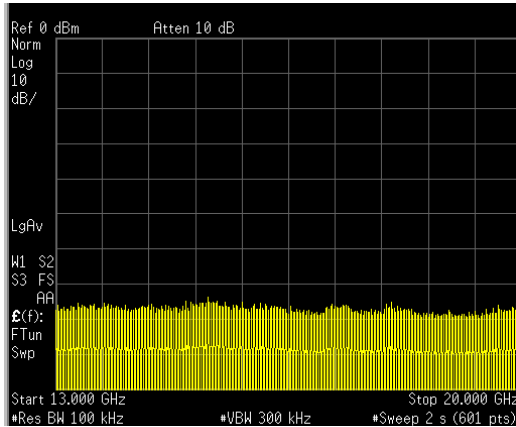

Spurious signal

0.80 μ s Pulse

13 to 20GHz

Scale
↑ 10dB/Div
→ 700MHz/Div

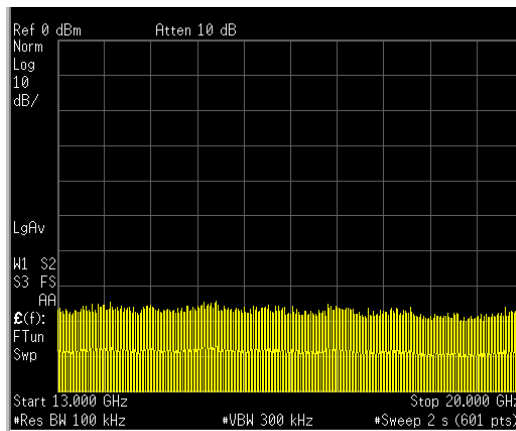

Spurious signal

1.0 μ s Pulse

13 to 20GHz

Scale
↑ 10dB/Div
→ 700MHz/Div

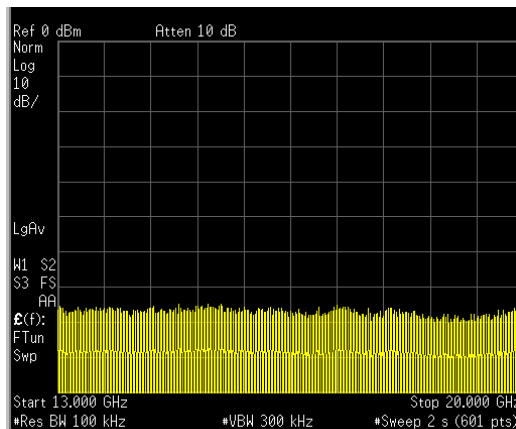

Spurious signal

1.2 μ s Pulse

13 to 20GHz

(Sec.2.1051) Spurious emission at antenna terminals

Condition 2: 12 to 28GHz

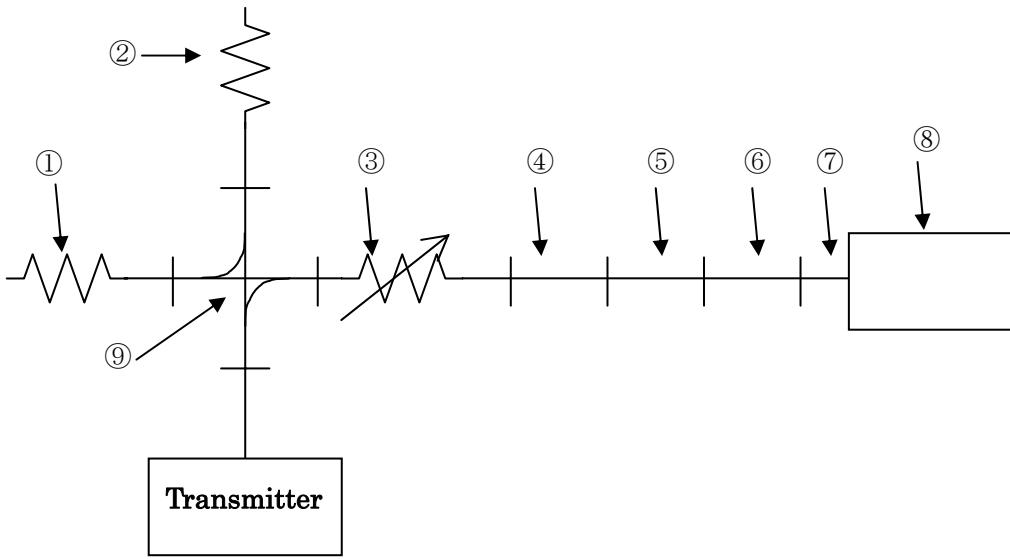

①Dummy Load	PE6815	PASTERNAK
②High Power Dummy Load	PE6824	PASTERNAK
③Attenuator	X382A	HP
④Tapered W/G	195-XV KU	AIRCOM
⑤Tapered W/G	11518A	HP
⑥Adaptor	22093-KF20	FLANN
⑦Coaxial Cable	SUCOFLEX101	HUBER+SUHNER
⑧Spectrum Analyzer	E4448A	Agilent
⑨Direction Coupler	5D363	SHIMADARIKA
Coupling	: 30dB	
Directivity	: 30dB	

Attenuation 3 : 40dB
 Measurement Point : Transmitter Output

(2.1051)

Scale
↑ 10dB/Div
→ 1.6GHz/Div

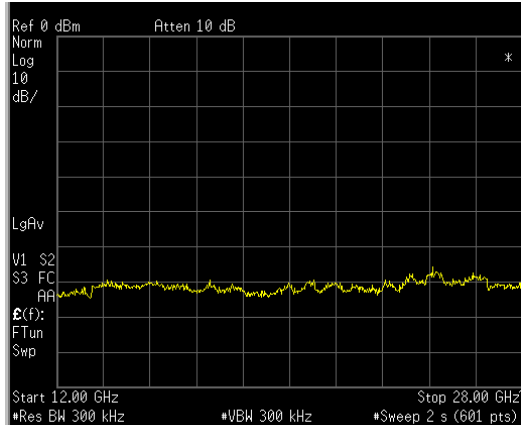

Spurious signal

OFF

12 to 28GHz

Scale
↑ 10dB/Div
→ 1.6GHz/Div

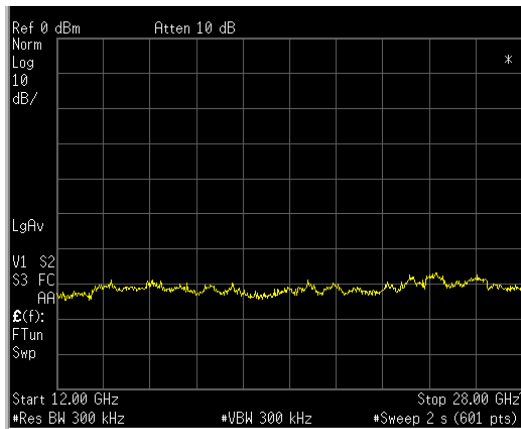

Spurious signal

Stand-By

12 to 28GHz

Scale
↑ 10dB/Div
→ 1.6GHz/Div

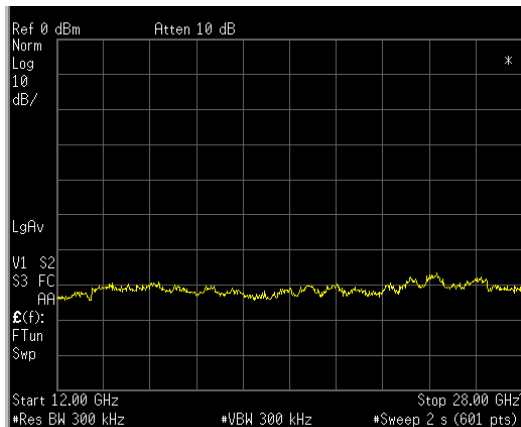

Spurious signal

0.070 μ s Pulse

12 to 28GHz

(2.1051)

Scale
↑ 10dB/Div
→ 1.6GHz/Div

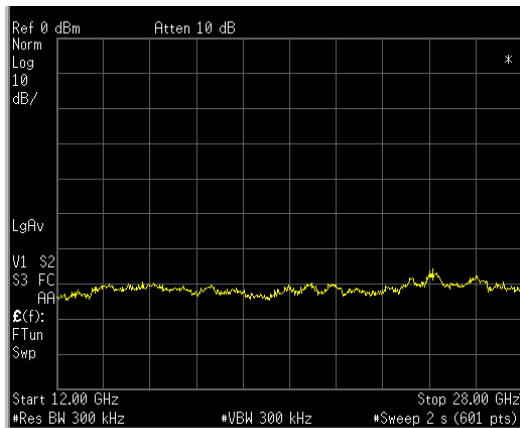

Spurious signal

0.20 μ s Pulse

12 to 28GHz

Scale
↑ 10dB/Div
→ 1.6GHz/Div

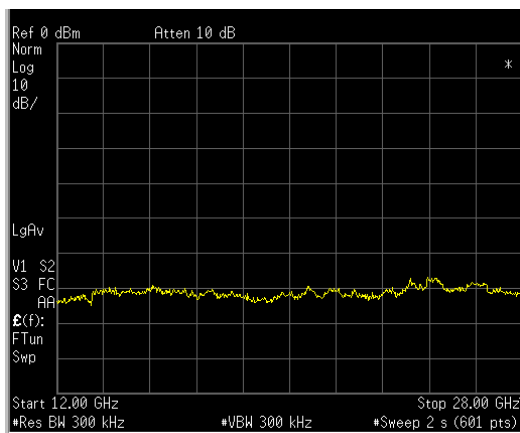

Spurious signal

0.30 μ s Pulse

12 to 28GHz

Scale
↑ 10dB/Div
→ 1.6GHz/Div

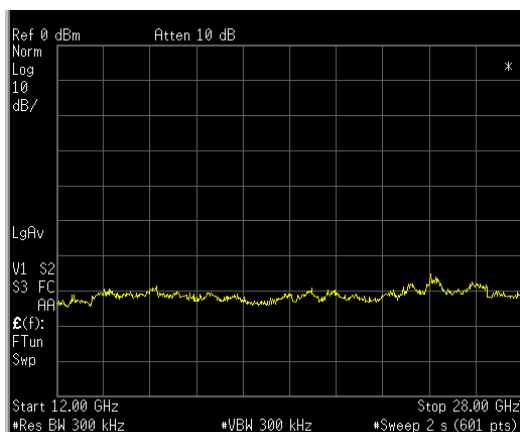

Spurious signal

0.40 μ s Pulse

12 to 28GHz

(2.1051)

Scale
↑ 10dB/Div
→ 1.6GHz/Div

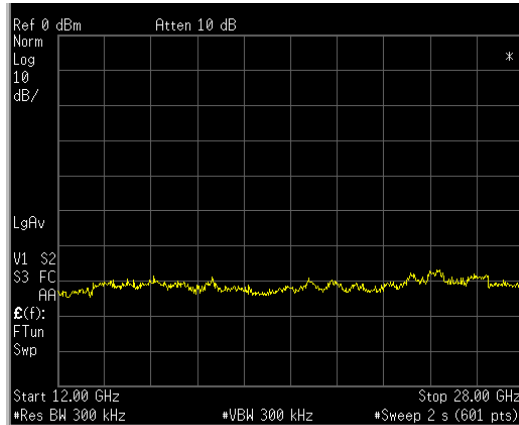

Spurious signal

0.80 μ s Pulse

12 to 28GHz

Scale
↑ 10dB/Div
→ 1.6GHz/Div

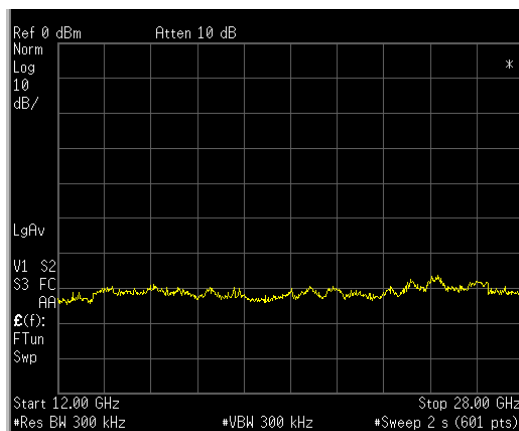

Spurious signal

1.0 μ s Pulse

12 to 28GHz

Scale
↑ 10dB/Div
→ 1.6GHz/Div

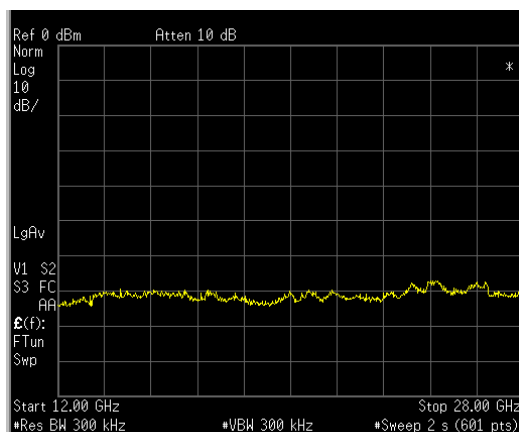

Spurious signal

1.2 μ s Pulse

12 to 28GHz

(Sec.2.1051) Spurious emission at antenna terminals

Condition 3: 28 to 50GHz

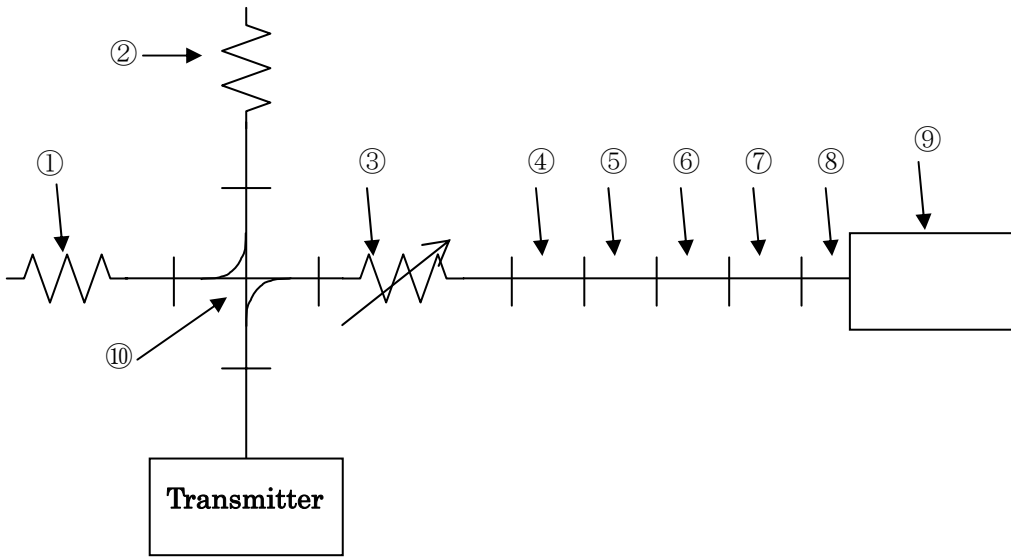

①Dummy Load	PE6815	PASTERNAK
②High Power Dummy Load	PE6824	PASTERNAK
③Attenuator	X382A	HP
④Tapered W/G	195-XV KU	AIRCOM
⑤Tapered W/G	11518A	HP
⑥Tapered W/G	11520A	HP
⑦Adaptor	22093-KF20	FLANN
⑧Coaxial Cable	SUCOFLEX101	HUBER+SUHNER
⑨Spectrum Analyzer	E4448A	Agilent
⑩Direction Coupler	5D363	SHIMADARIKA
Coupling	: 30dB	
Directivity	: 30dB	

Attenuation 3 : 40dB
 Measurement Point : Transmitter Output

(2.1051)

Scale
↑ 10dB/Div
→ 2.2GHz/Div

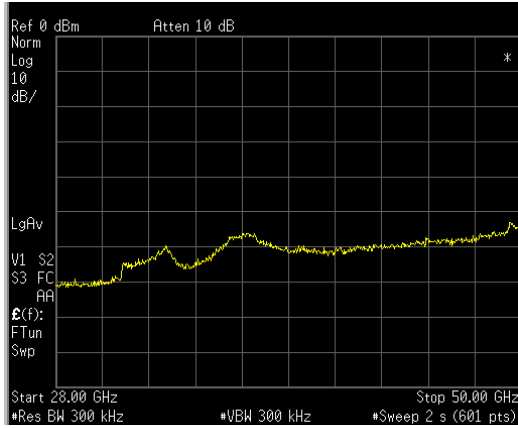

Spurious signal

OFF

28 to 50GHz

Scale
↑ 10dB/Div
→ 2.2GHz/Div

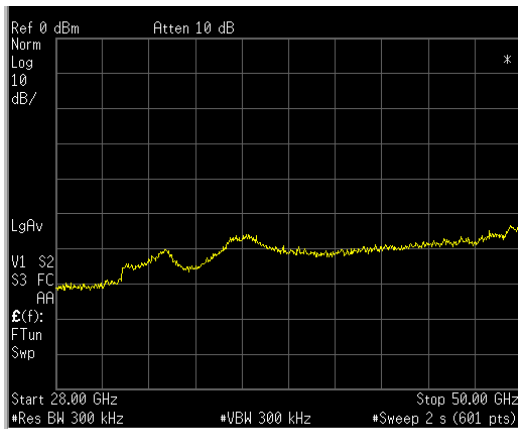

Spurious signal

Stand-By

28 to 50GHz

Scale
↑ 10dB/Div
→ 2.2GHz/Div

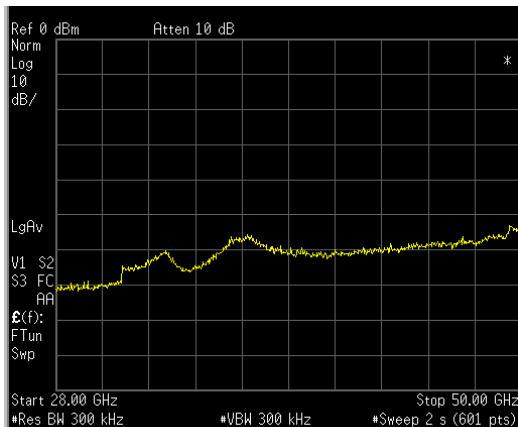

Spurious signal

0.070 μ s Pulse

28 to 50GHz

(2.1051)

Scale
↑ 10dB/Div
→ 2.2GHz/Div

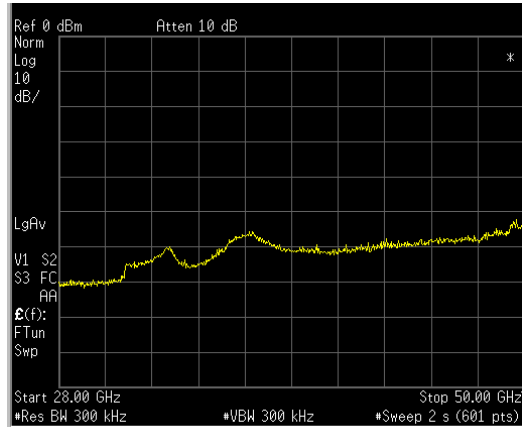

Spurious signal

0.20 μ s Pulse

28 to 50GHz

Scale
↑ 10dB/Div
→ 2.2GHz/Div

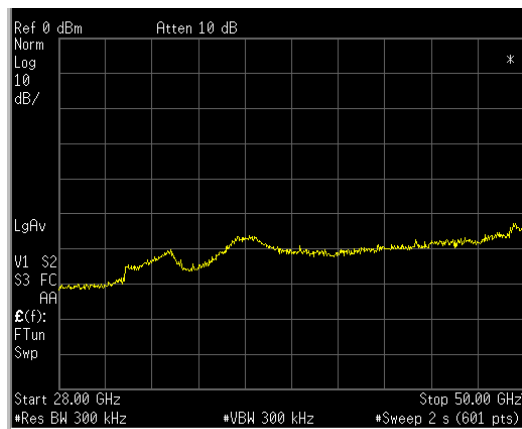

Spurious signal

0.30 μ s Pulse

28 to 50GHz

Scale
↑ 10dB/Div
→ 2.2GHz/Div

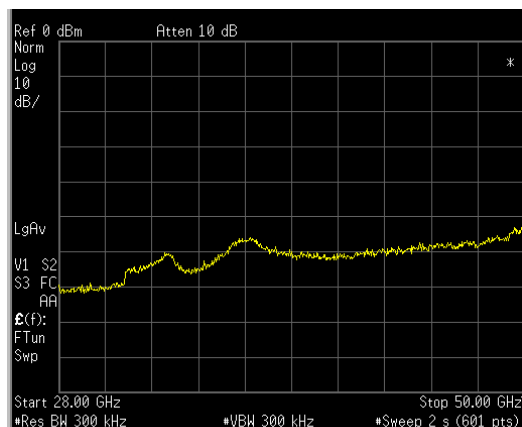

Spurious signal

0.40 μ s Pulse

28 to 50GHz

(2.1051)

Scale
↑ 10dB/Div
→ 2.2GHz/Div

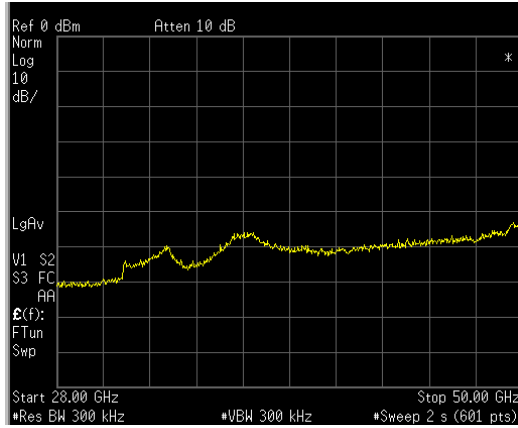

Spurious signal
0.80 μ s Pulse
28 to 50GHz

Scale
↑ 10dB/Div
→ 2.2GHz/Div

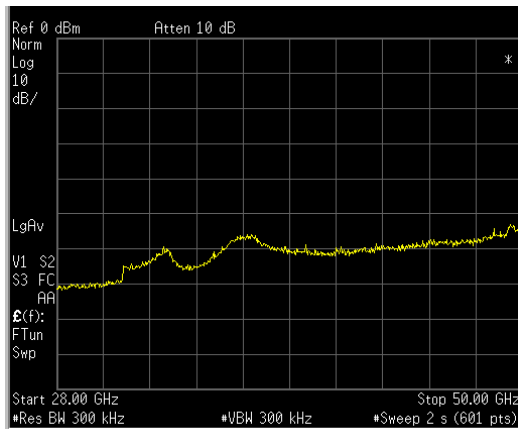

Spurious signal
1.0 μ s Pulse
28 to 50GHz

Scale
↑ 10dB/Div
→ 2.2GHz/Div

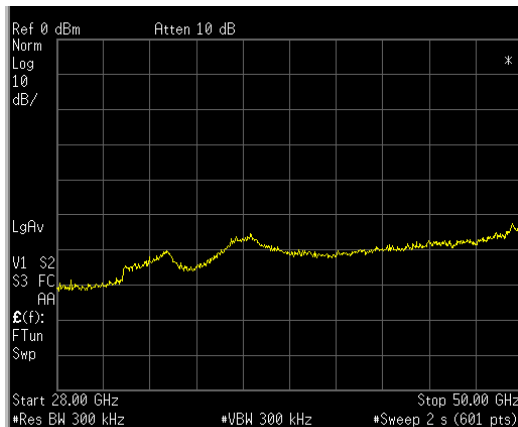

Spurious signal
1.2 μ s Pulse
28 to 50GHz

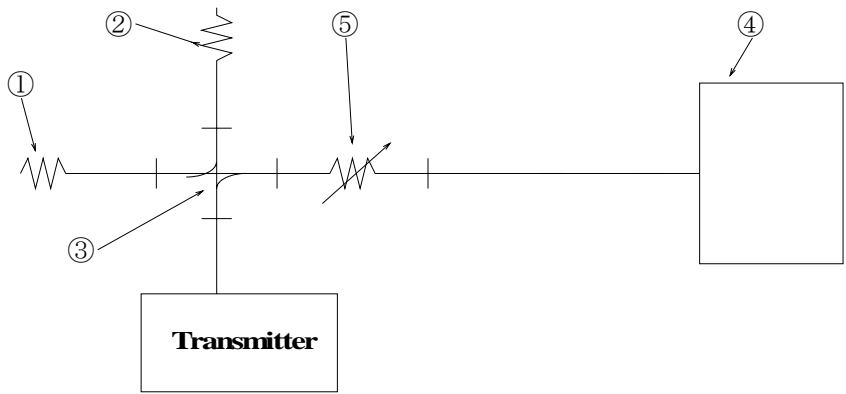

1. Dummy Load	PE6815	PASTERNAK
2. High Power Dummy Load	PE6824	PASTERNAK
3. Directional Coupler	5D363	SHIMADARIKA
Coupling	30dB	
Directivity	30dB	
4. Spectrum Analyzer	E4448A	Agilent
5. Attenuator	8495B	HP
Temperature Chamber	T-15S	TABAI

Measurement Procedure

- 1 The antenna pedestal, Transceiver and display unit were set up in the temperature chamber and the measurement equipment were set outside the temperature chamber.
- 2 With power removed , the temperature was decreased to – 30 °C and permitted to stabilize for three hours. Power was applied and measured warm-up time. After 30 minutes place the radar in X-MIT, measured frequency at AC85V (AC100V-15%), AC132.25V (AC115V+15%).
- 3 With power off , the temperature was raised in 10 °C steps. The sample was permitted to stabilize at each step for at least three hours. Power was applied and measured warm-up time. After 30 minutes place the radar in X-MIT, measured frequency at AC85V (AC100V-15%), AC132.25V (AC115V+15%).

Temperature [°C]	Operating Frequency [MHz]						Warm-Up Time (min) <X-MIT>
	0.07 μ S Pulse		0.2 μ S Pulse		0.3 μ S Pulse		
	AC85V	AC132.25V	AC85V	AC132.25V	AC85V	AC132.25V	
- 25	9427	9426	9424	9424	9423	9423	30
- 20	9426	9426	9423	9423	9423	9423	30
- 10	9423	9424	9423	9423	9423	9424	30
0	9421	9422	9420	9420	9420	9421	30
+10	9420	9420	9418	9419	9417	9417	30
+20	9418	9417	9416	9416	9415	9415	30
+30	9416	9416	9414	9414	9413	9413	30
+40	9415	9415	9413	9413	9413	9413	30
+50	9415	9415	9413	9413	9413	9413	30
+55	9415	9415	9413	9413	9413	9413	30

Temperature [°C]	Operating Frequency [MHz]						Warm-Up Time (min) <X-MIT>
	0.4 μ S Pulse		0.8 μ S Pulse		1.0 μ S Pulse		
	AC85V	AC132.25V	AC85V	AC132.25V	AC85V	AC132.25V	
- 25	9421	9422	9421	9420	9420	9419	30
- 20	9421	9422	9421	9420	9420	9419	30
- 10	9421	9421	9420	9420	9419	9419	30
0	9418	9419	9417	9417	9417	9417	30
+10	9416	9416	9415	9416	9415	9415	30
+20	9415	9415	9414	9415	9414	9414	30
+30	9412	9412	9411	9411	9412	9412	30
+40	9411	9411	9410	9410	9411	9411	30
+50	9410	9410	9408	9408	9411	9411	30
+55	9410	9410	9408	9408	9411	9410	30

Temperature [°C]	Operating Frequency [MHz]						Warm-Up Time (min) <X-MIT>
	1.2 μ S Pulse						
	AC85V	AC132.25V					
- 25	9420	9420					30
- 20	9420	9420					30
- 10	9420	9419					30
0	9417	9416					30
+10	9415	9414					30
+20	9414	9414					30
+30	9411	9411					30
+40	9410	9411					30
+50	9409	9410					30
+55	9409	9409					30

SECTION 5

TEST: Spurious Emissions Field Strength

EQUIPMENT: JMA-9122 S/N LB00421

FCC SPECIFICATION: Sections 2.1053.

MINIMUM STANDARD: Mean power of emissions originating in equipment lowest generated frequency to at least 40 GHz shall be attenuated below the mean power of the transmitter by at least 43 plus 10 log (mean power in watts) decibels. Since transmitter mean power is 11.1 watts maximum (long pulse) or 40.5 dBm:

$$\begin{aligned} \text{Emissions} &\leq 40.5 \text{ dBm} - [43 + 10 \log(11.1)] \text{ dBm} \\ &\leq -13.0 \text{ dBm} \end{aligned}$$

TEST RESULTS: No spurious emissions observed above minimum standard.

TEST CONDITIONS: Tamb = 20°C to 25°C RHamb = 40% ~ 60%
Eut input = 48 VDC

STABILIZATION: EUT energized for 10 minutes minimum.

TEST EQUIPMENT: JRC Original – Shielded Room
Other equipment – see test set-ups.

DATE: July,25.2008

TEST ENGINEER: M.ITOH

CALIBRATION OF TESTS 1~5 (0~1GHz)

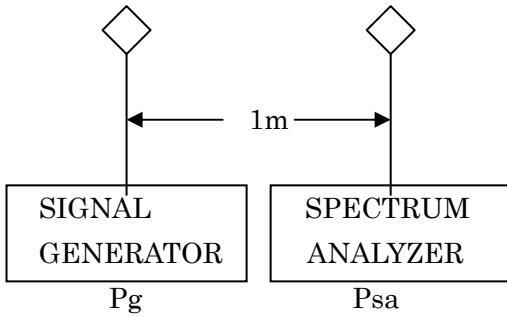

A signal source of known amplitude was used as a calibrating signal with identical antenna on the generator and the spectrum analyzer.

From previous testing in the shielded room, the antenna factors are considered much greater than path loss.

Hence half of the difference in signals Pg and Psa is due to each antenna.

The calibrating signal on the analyzer is therefore:

$$P_{cal} = P_{sa} - (P_{sa} - P_g) / 2 = (P_{sa} + P_g) / 2 \text{ dBm.}$$

The log ref level on the analyzer is adjusted so as to read other signals directly:

$$\text{LRL (adjusted)} = \text{LRL(set)} + P_{cal} - P_{sa} \text{ dBm.}$$

The calibrating signal used was selected on the basis of best average amplitude over the frequency range of interest.

TEST	CAL sig	Psa	Pg	Pcal	LRL(set)	LRL(adj)
1	250 kHz	-72	0	-36.0	0	36.0
2	2.5 MHz	-54	0	-27.0	0	27.0
3	25 MHz	-30	0	-15.0	0	15.0
4	250 MHz	-33	0	-16.5	0	16.5
5	500 MHz	-28	0	-14.0	0	14.0

TEST #1 Frequency Band: 0~500KHz

Log Ref. Level:36.0 dBm

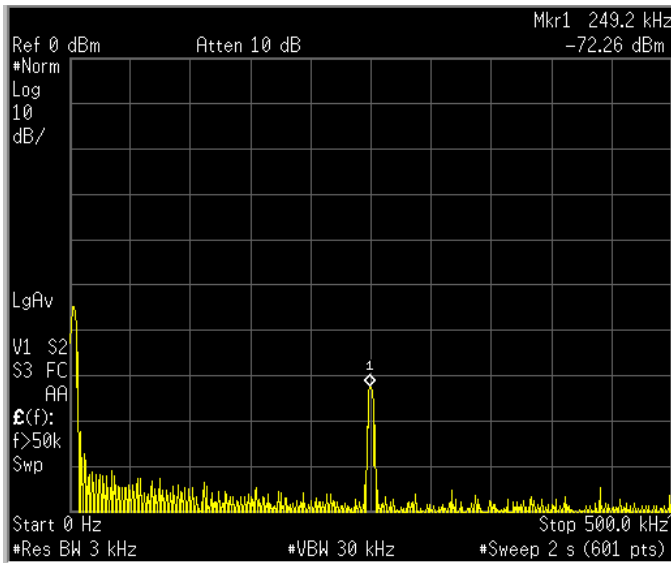

Ambient

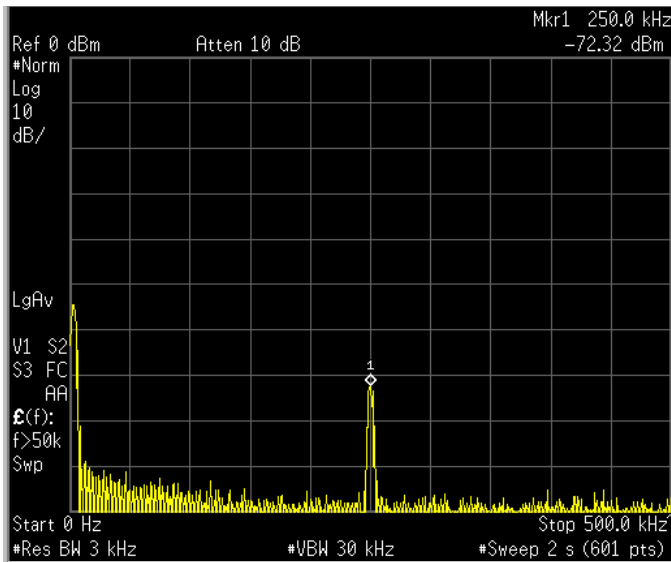

Stand-By

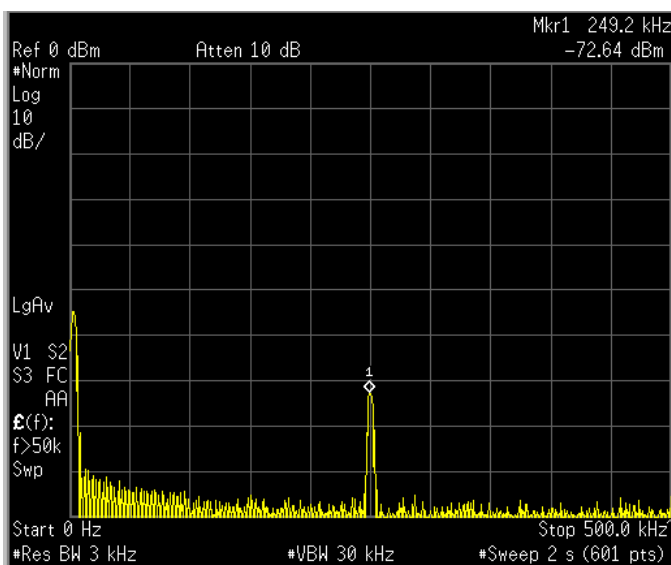

0.07 μ S Pulse

TEST #1 Frequency Band: 0~500KHz

Log Ref. Level:36.0 dBm

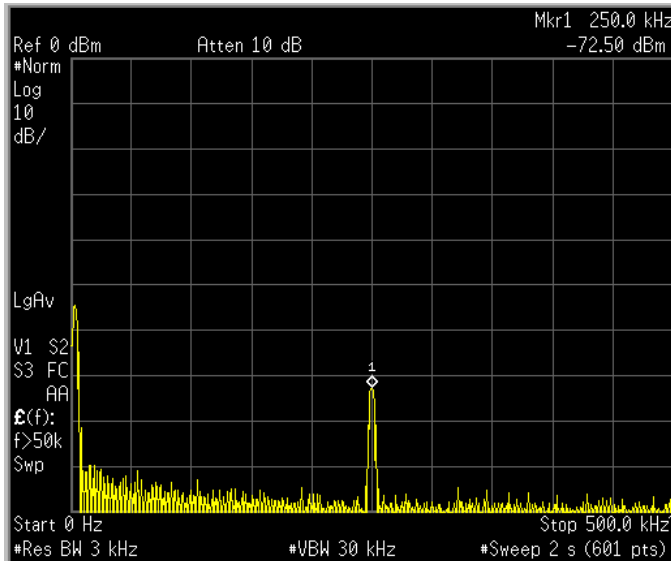

0.2 μ S Pulse

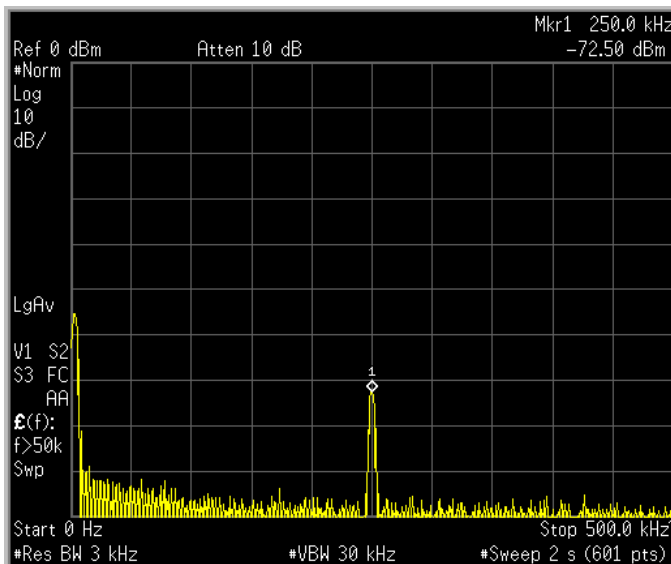

0.3 μ S Pulse

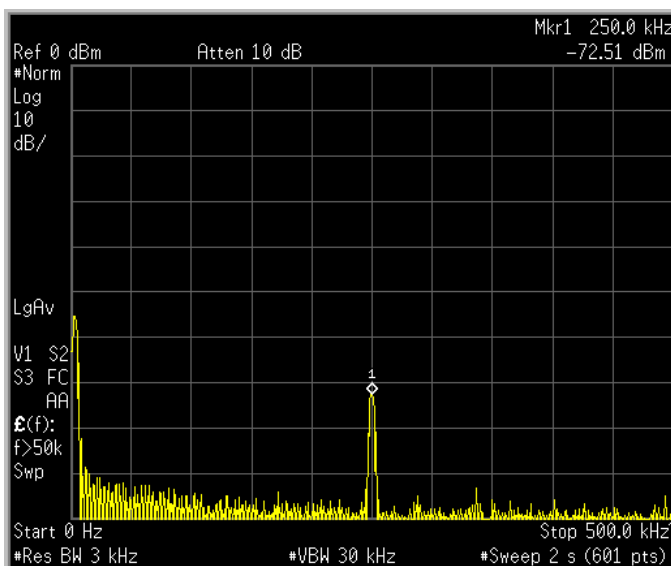

0.4 μ S Pulse

TEST #1 Frequency Band: 0~500KHz

Log Ref. Level:36.0 dBm

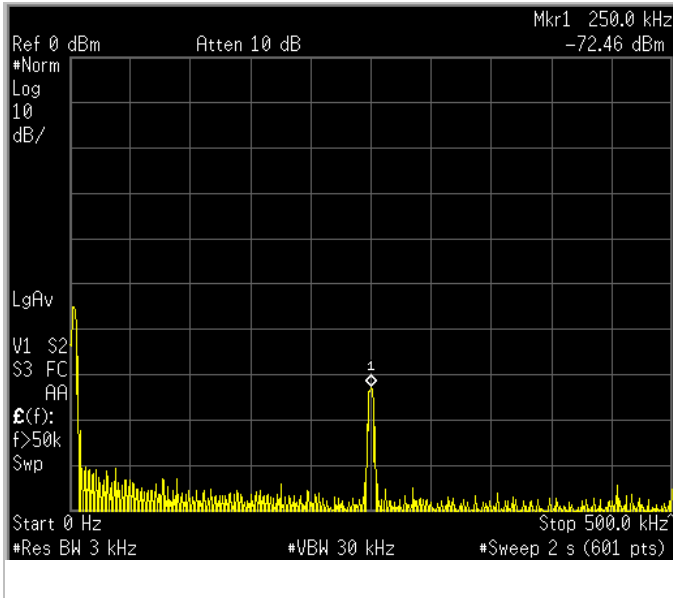

0.8 μ S Pulse

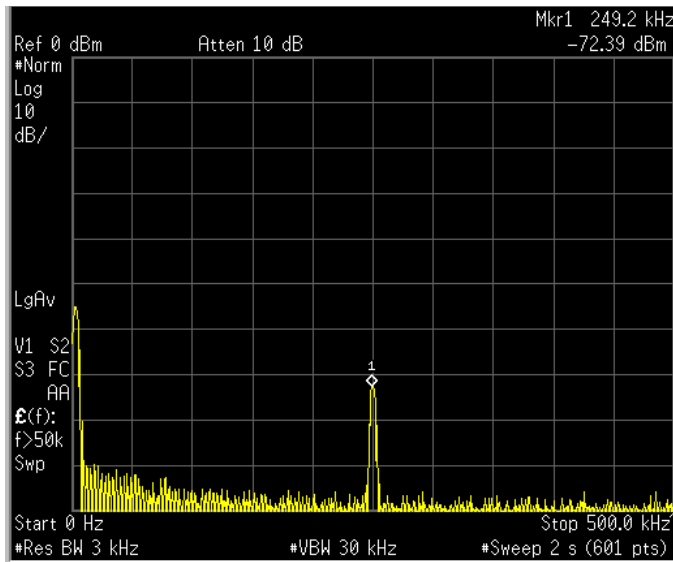

1.0 μ S Pulse

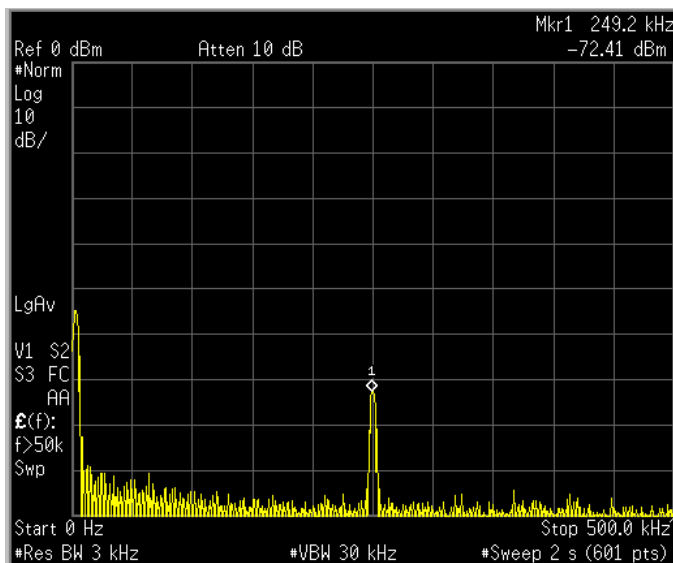

1.2 μ S Pulse

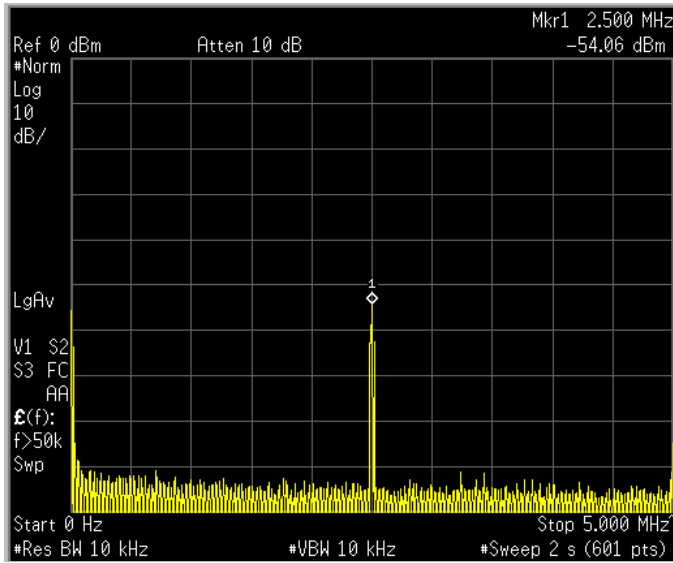

Ambient

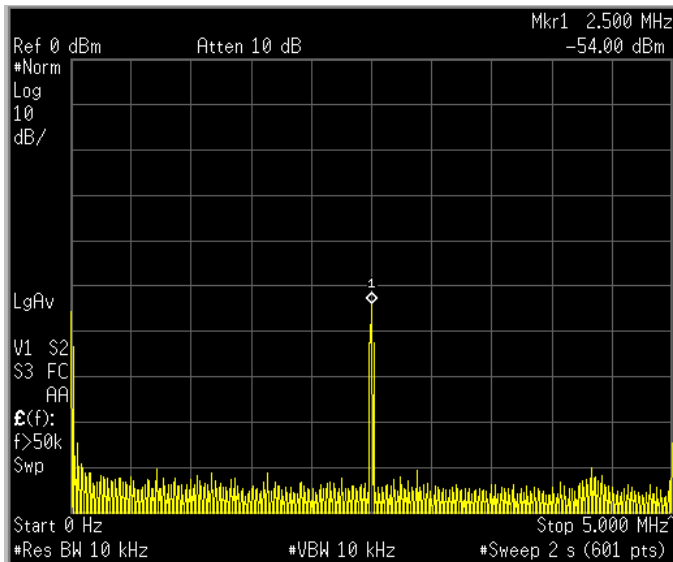

Stand-By

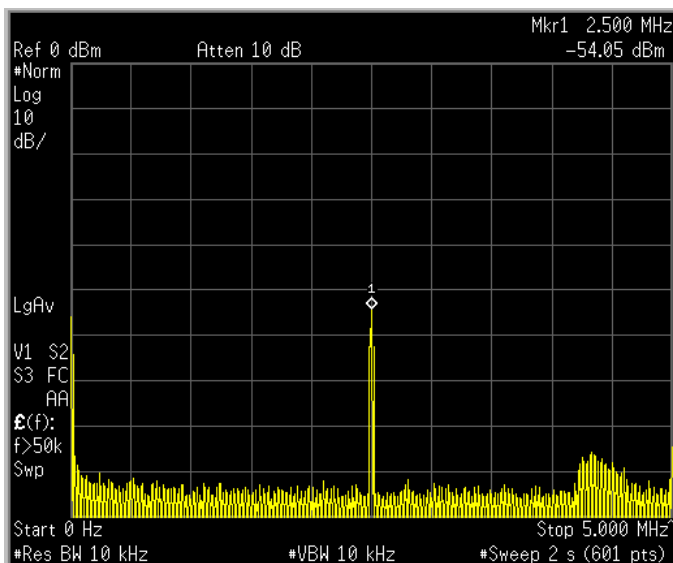

0.07 μ S Pulse

TEST #2 Frequency Band: 0~5MHz

Log Ref. Level:27.0 dBm

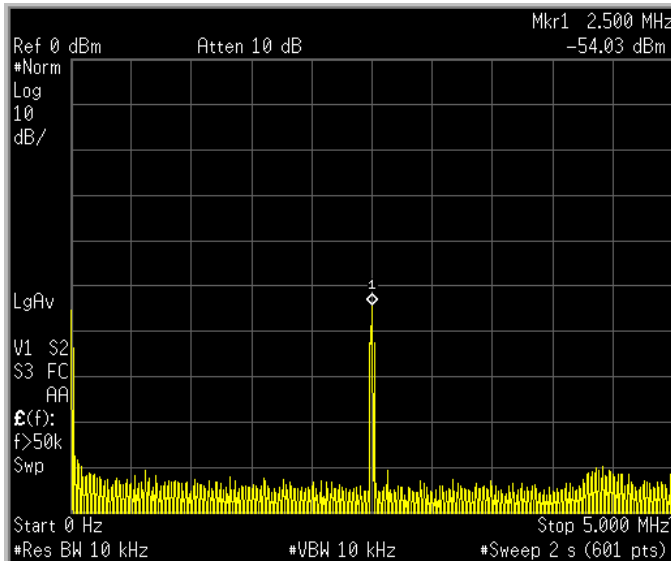

0.2 μ S Pulse

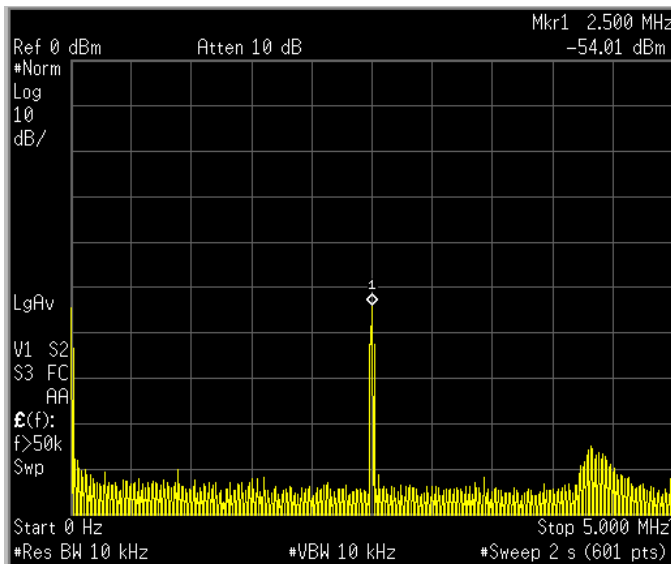

0.3 μ S Pulse

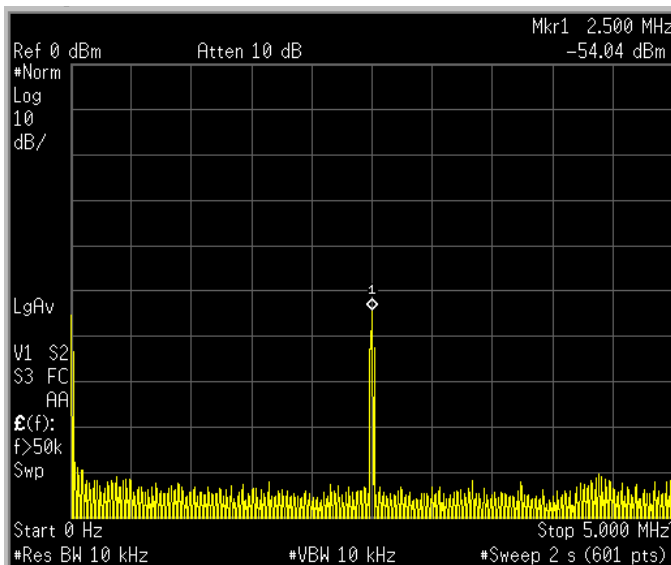

0.4 μ S Pulse

TEST #2 Frequency Band: 0~5MHz

Log Ref. Level:27.0 dBm

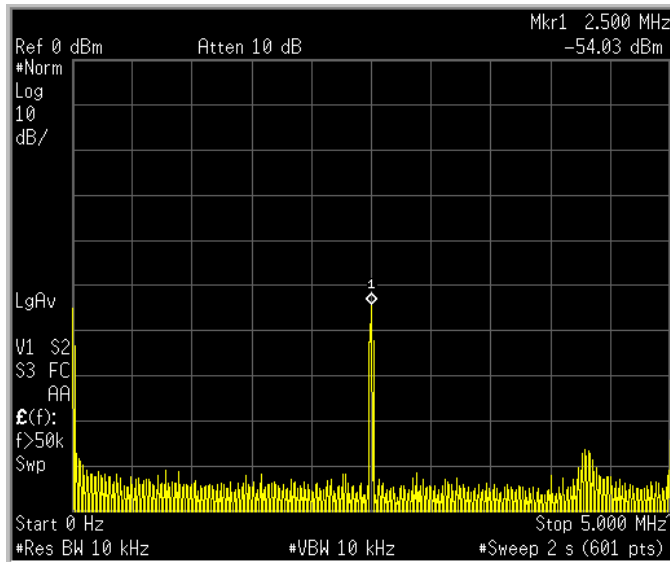

0.8 μ S Pulse

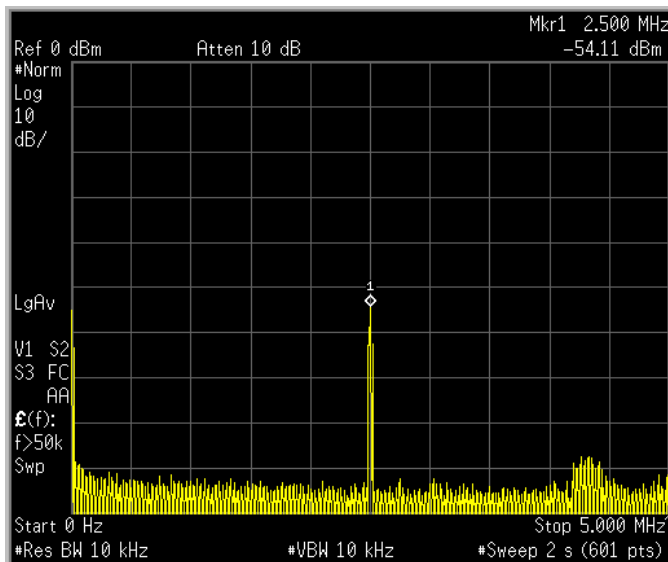

1.0 μ S Pulse

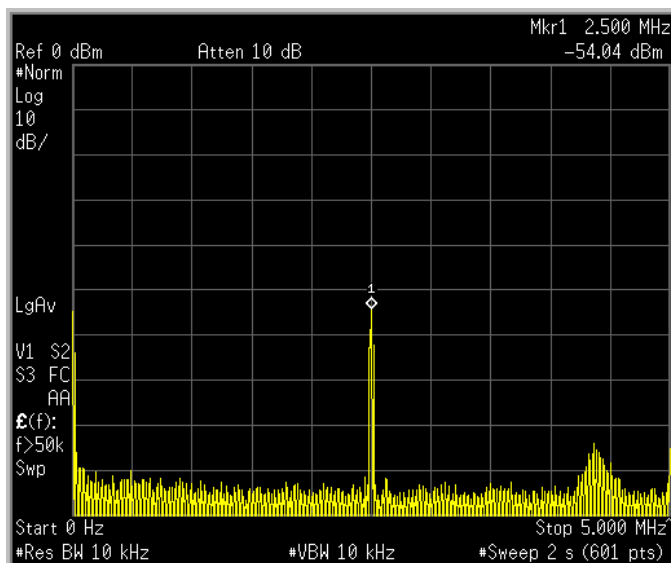

1.2 μ S Pulse

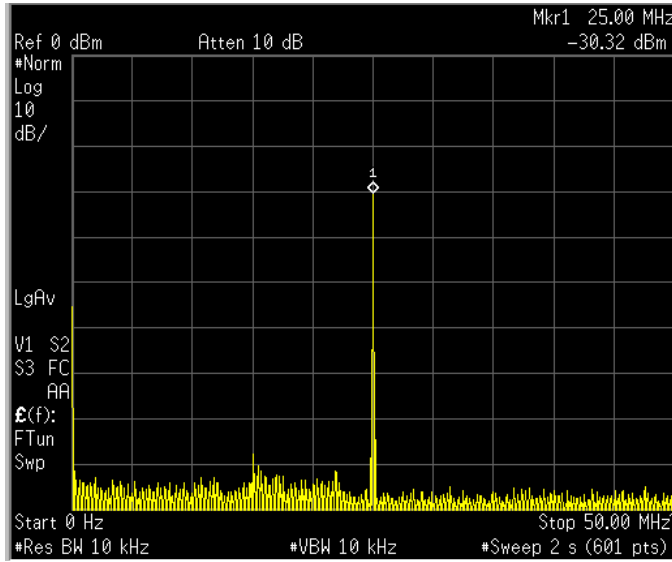

Ambient

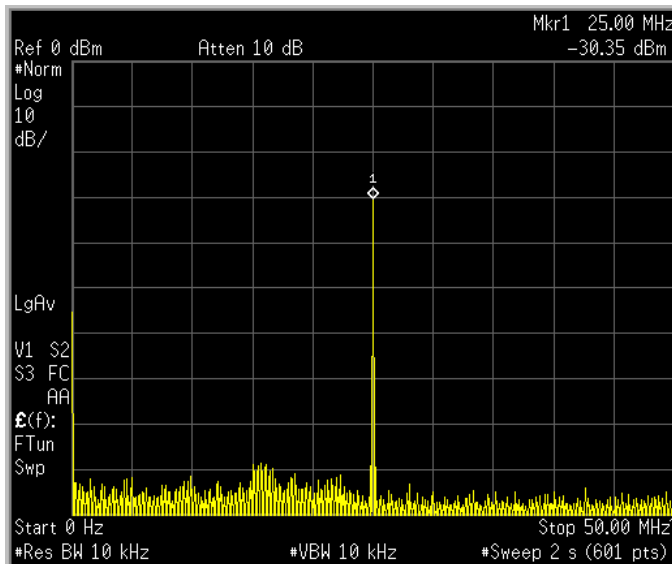

Stand-By

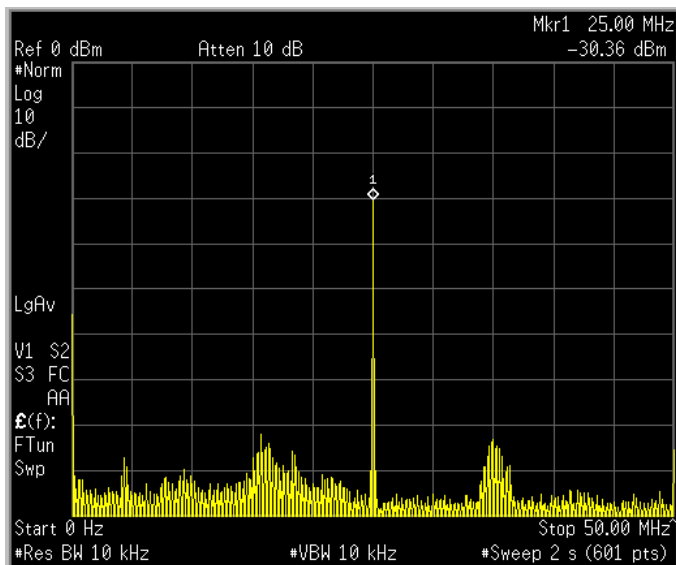

0.07 μ S Pulse

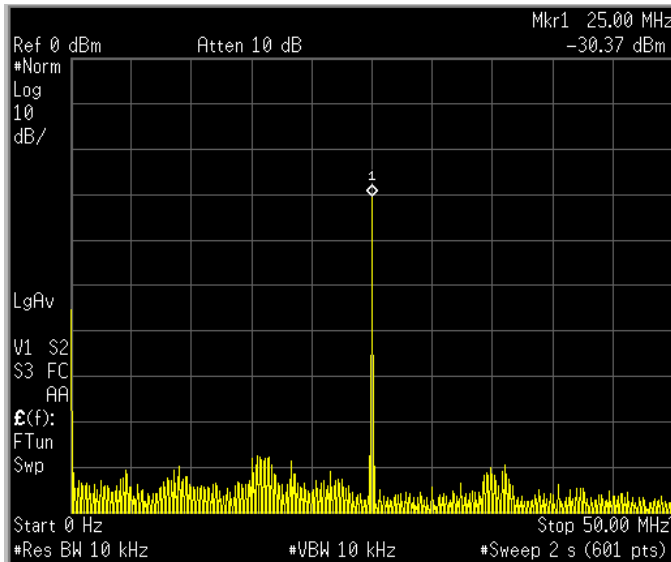

0.2 μ S Pulse

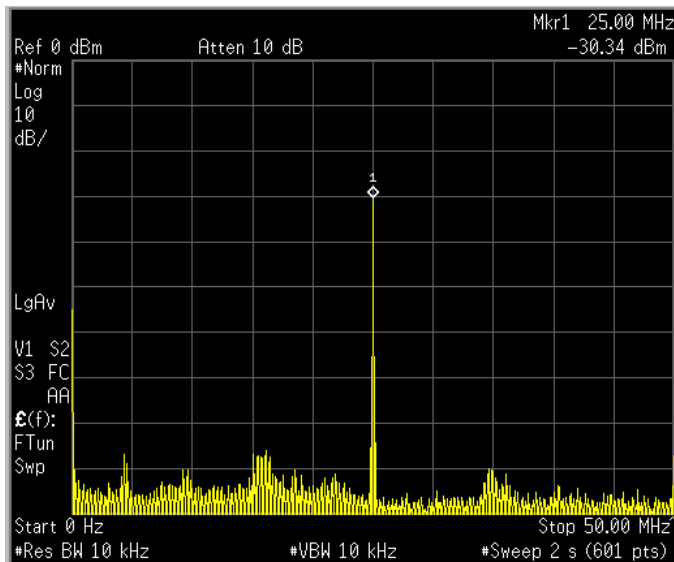

0.3 μ S Pulse

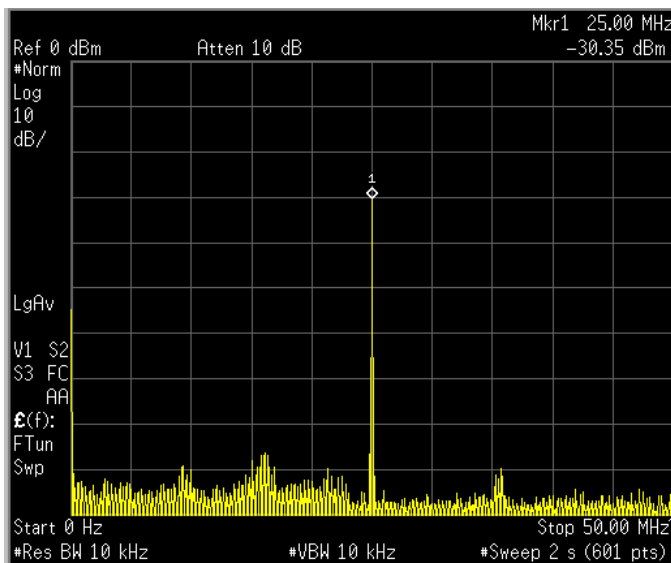

0.4 μ S Pulse

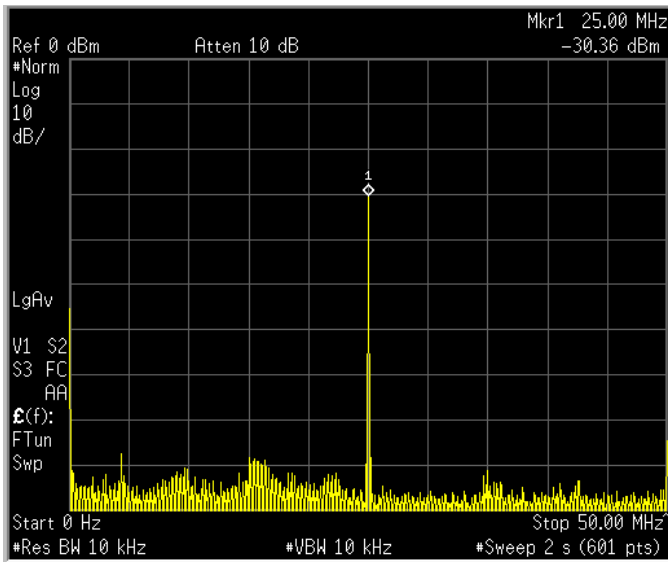

0.8 μ S Pulse

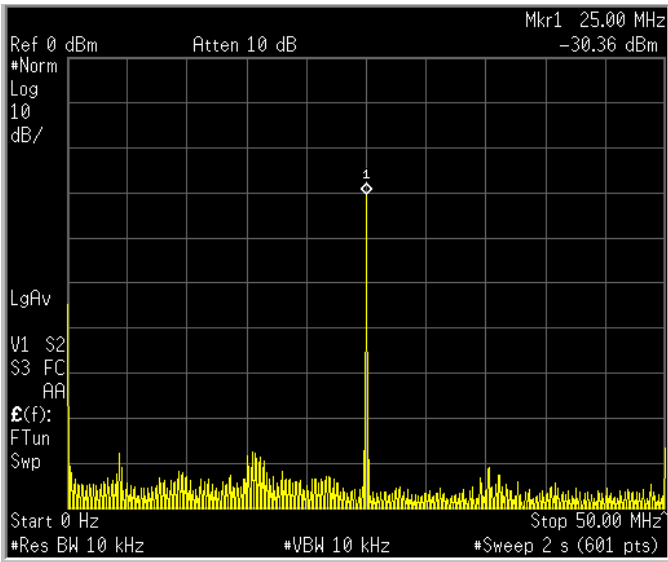

1.0 μ S Pulse

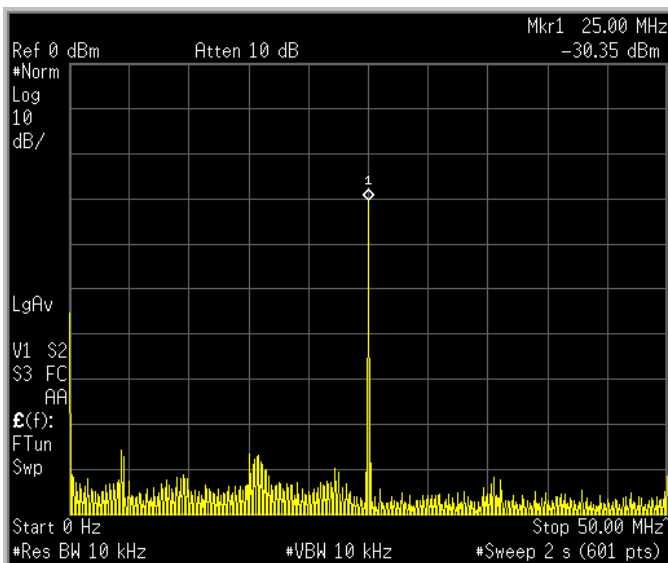

1.2 μ S Pulse

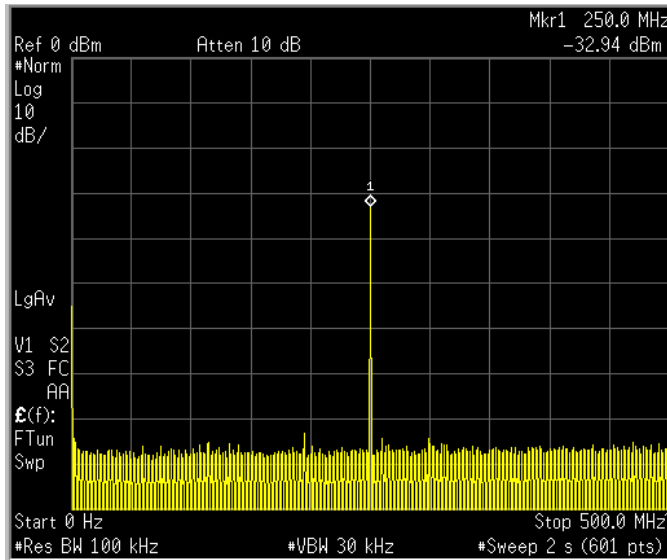

Ambient

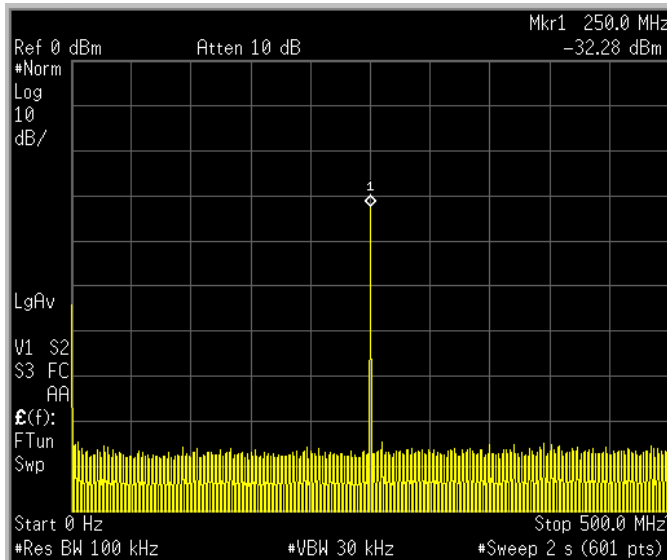

Stand-By

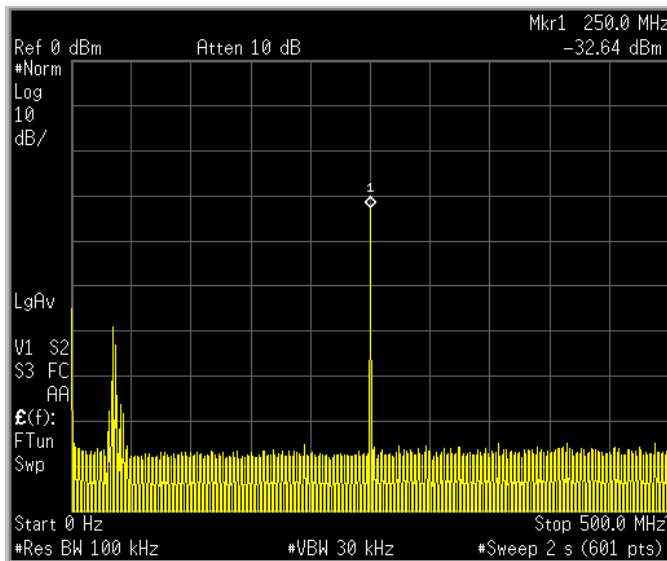

0.07 μ S Pulse

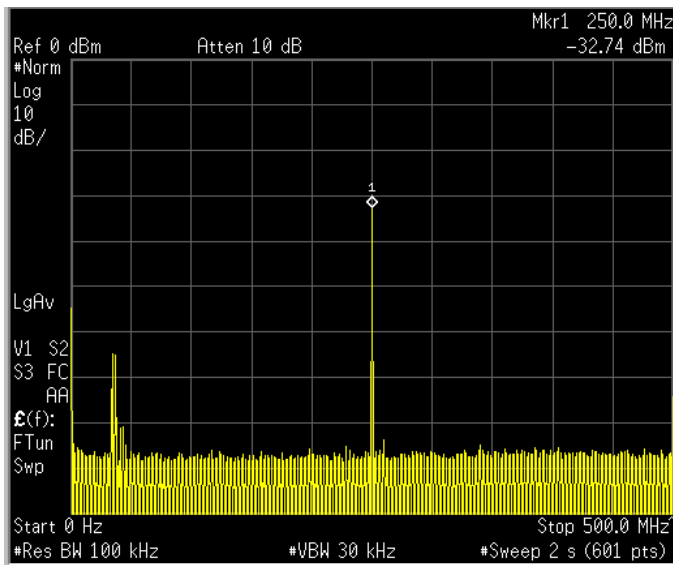

0.2 μ S Pulse

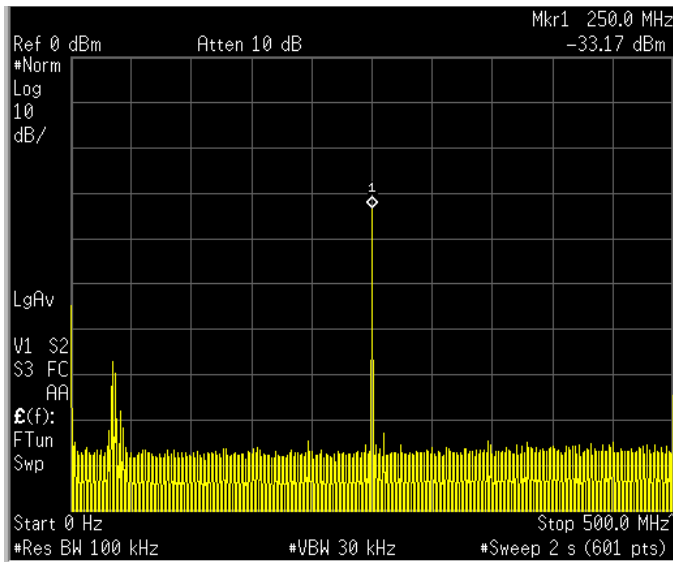

0.3 μ S Pulse

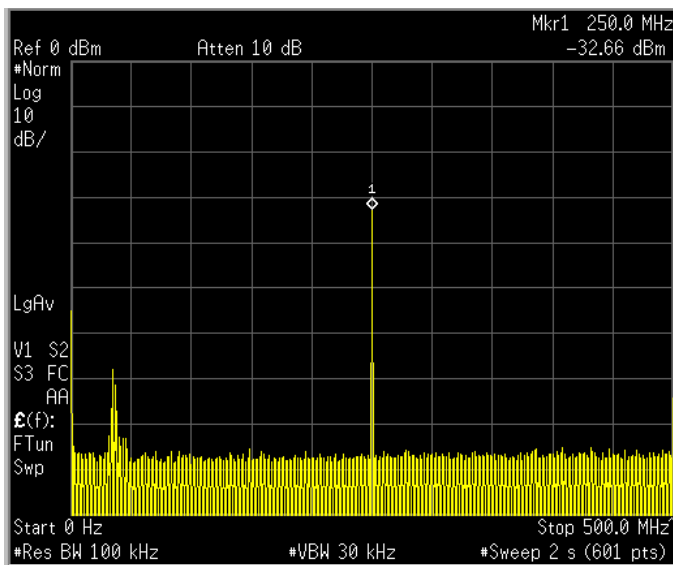

0.4 μ S Pulse

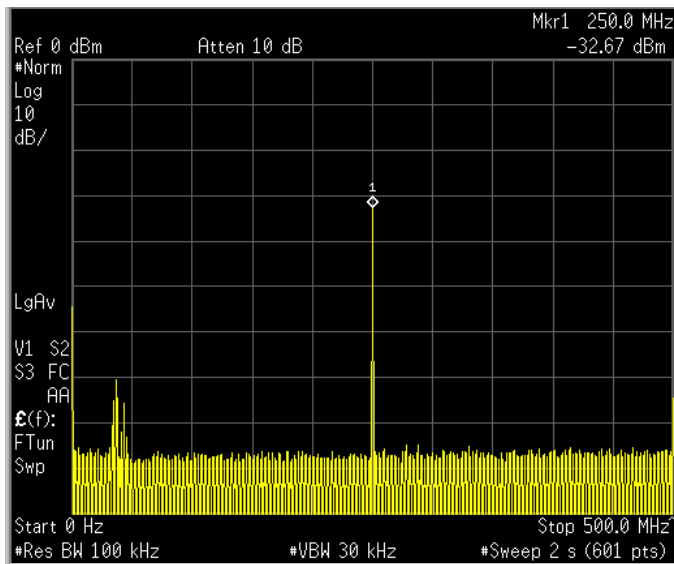

0.8 μ S Pulse

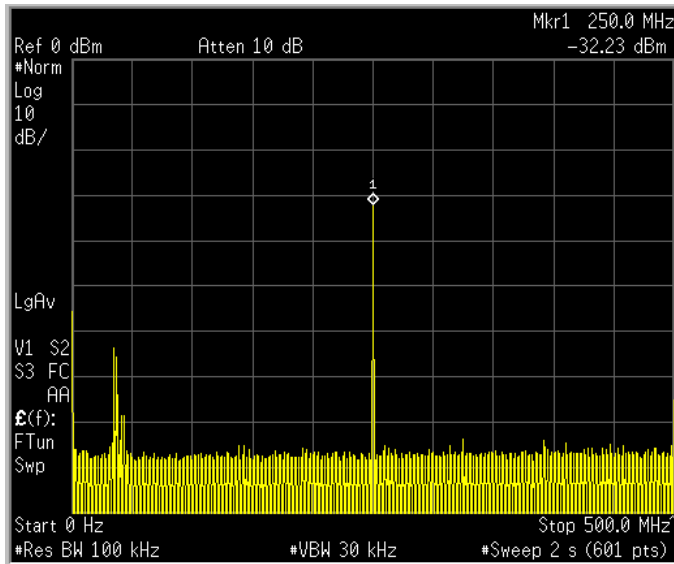

1.0 μ S Pulse

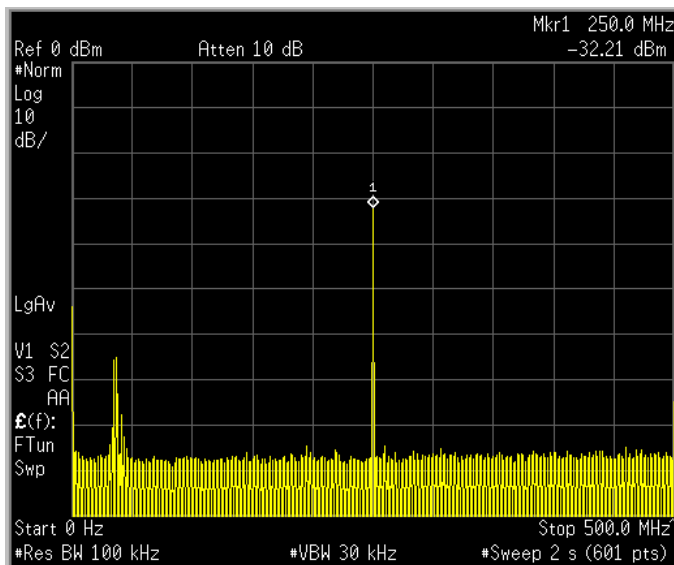

1.2 μ S Pulse

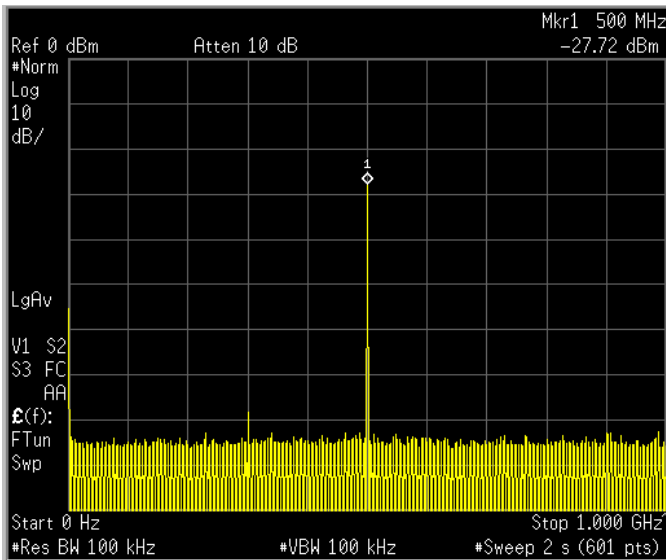

Ambient

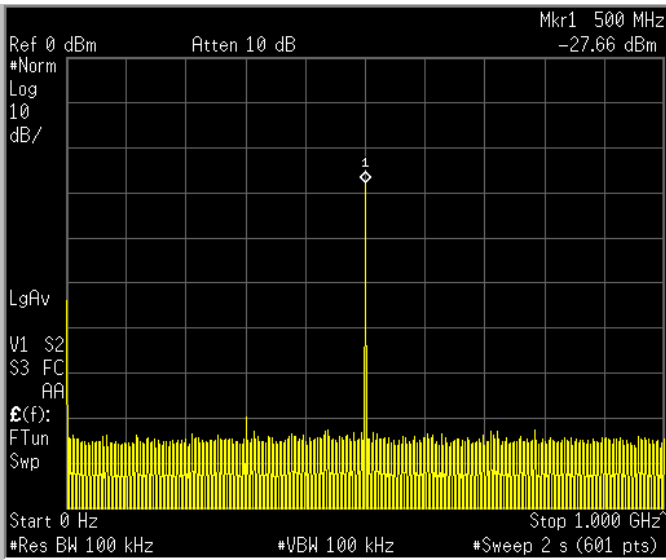

Stand-By

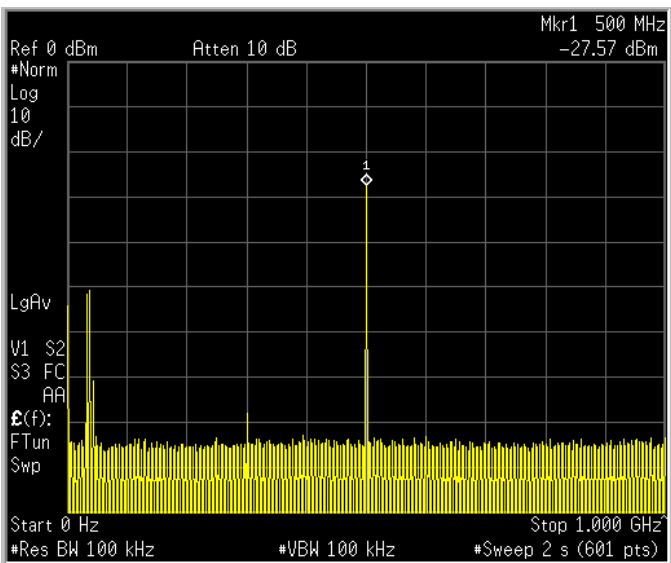

0.07 μ S Pulse

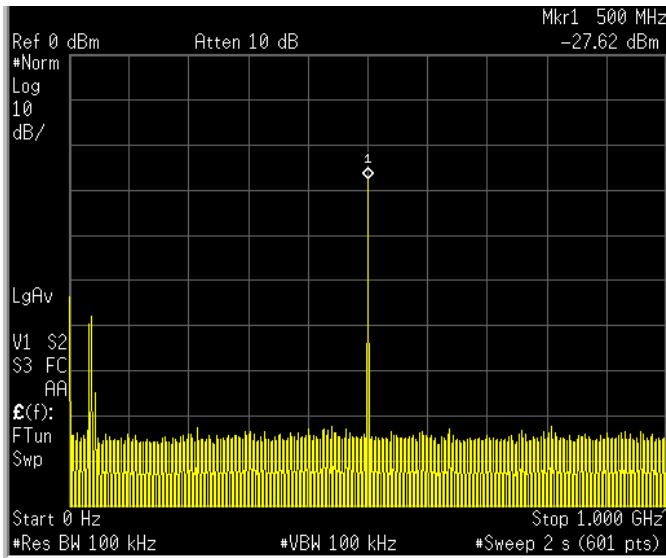

0.2 μ S Pulse

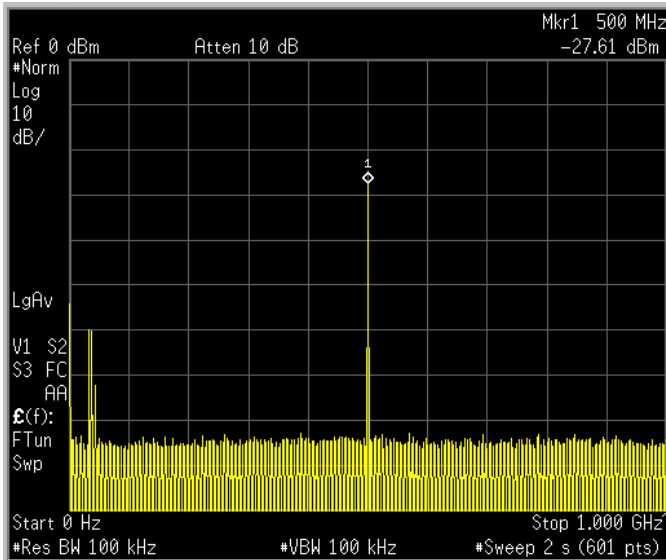

0.3 μ S Pulse

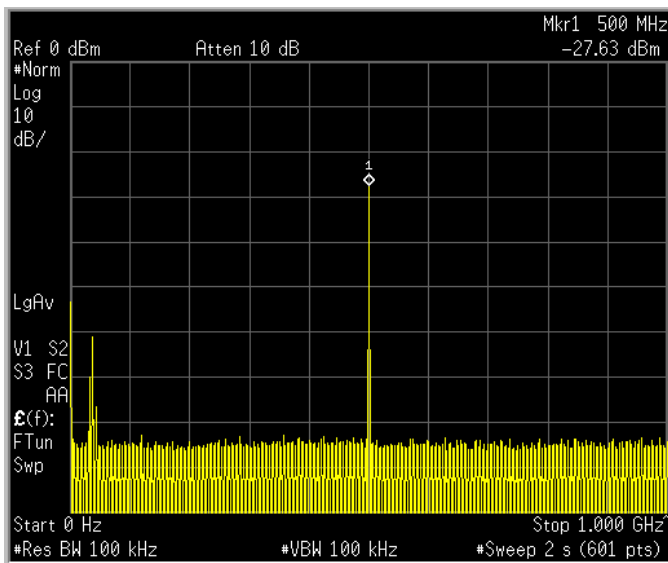

0.4 μ S Pulse

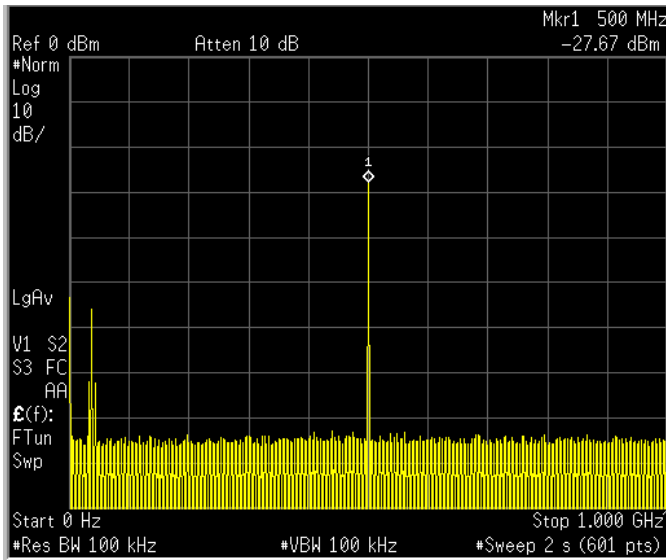

0.8 μ S Pulse

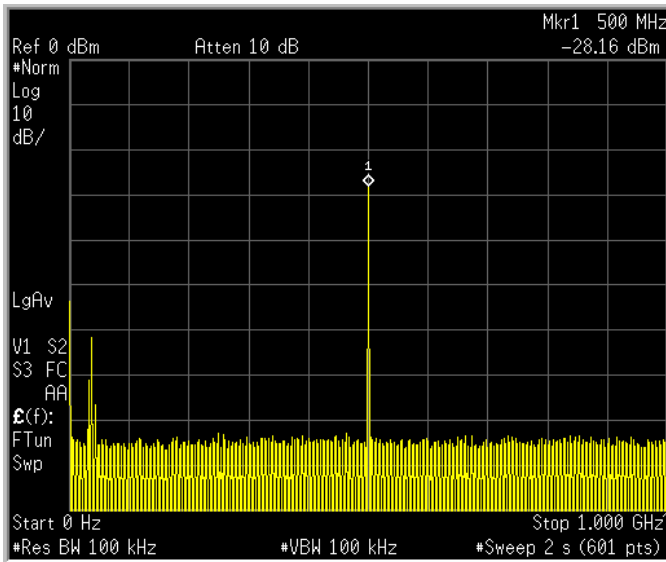

1.0 μ S Pulse

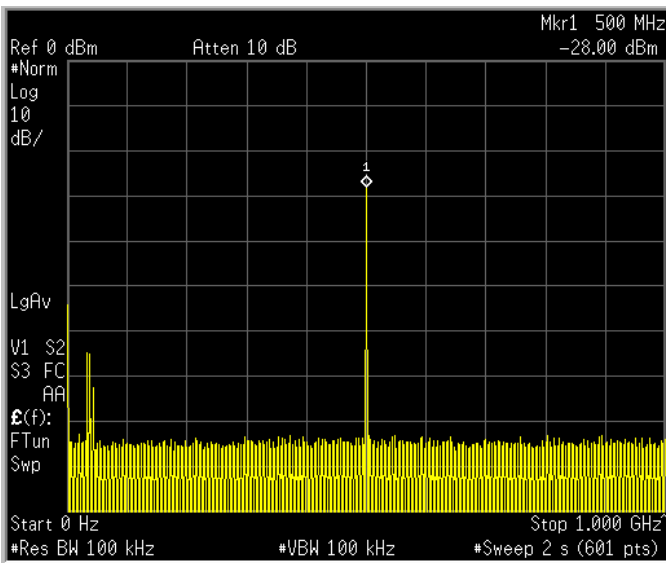

1.2 μ S Pulse

CALIBRATION OF TESTS 6~11 (1~50 GHz)

Instead of using a signal source of known amplitude to calibrate the receiving system, the path and antenna characteristics were computed.

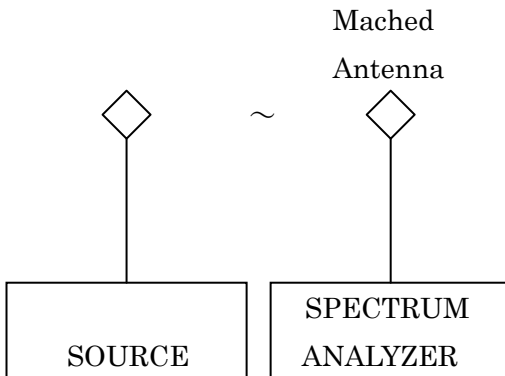

The power density at distance R is :
$$P = \frac{1.64 P_t}{4 \pi R^2}$$

Where P_t is power transmitted.
 The power to the analyzer is :
$$P_{sa} = P_{Ar} = \frac{P G \lambda^2}{4 \pi}$$

Where G is the receiving antenna gain and A_r is the effective area of the receiving antenna

Hence
$$P_{sa} = \frac{1.64 P_t}{4 \pi R^2} \times \frac{P G \lambda^2}{4 \pi} = \frac{1.6 G \lambda^2}{16 \pi^2} \times P_t \text{ at 1 meter}$$

and
$$P_t = \frac{16 \pi^2 P_{sa}}{1.64 G \lambda^2} = \frac{96.3 P_{sa}}{G \lambda^2}$$

$= P_{sa} \text{ (dBm)} + 19.8 \text{ (dB)} - G \text{ (dB)} - 20 \log \lambda \text{ (dB)}$

TEST	HORN GAIN		WAVELENGTH		Pt - Psa		LOG REF LEVEL	
	(AVG)	dB	(dB)		LO	HI		
	LO	HI	LO	HI	LO	HI		
6		6	-10.5	-21.6	24.3	35.4	0 dBm	0 – 2.9 G
7		6	-21.3	-28.0	35.1	41.8	0 dBm	2.9 – 6.4 G
8		6	-27.6	-34.1	41.4	47.9	0 dBm	6.4 – 12.5G
9		6	-31.2	-35.6	45.0	49.4	0 dBm	12.5 – 20 G
10	23.3	24.9	-35.6	-38.8	32.1	33.7	0 dBm	12.4 – 28 G
11	23.6	25.1	-39.4	-42.5	35.6	37.2	0 dBm	28 – 50 G

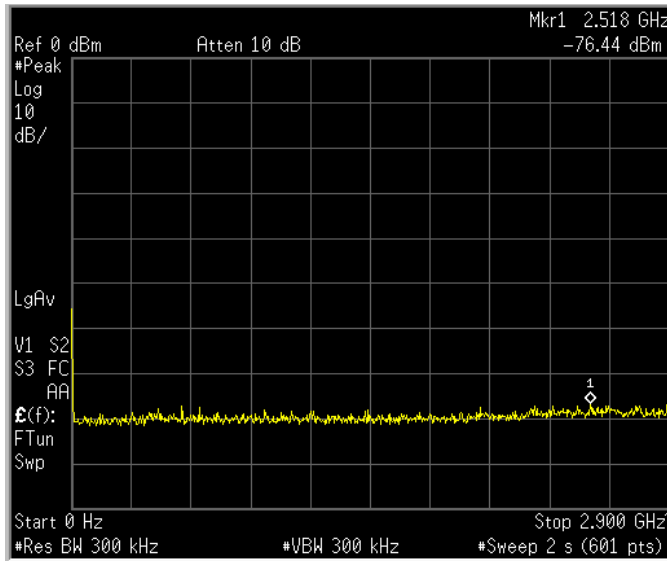

Ambient

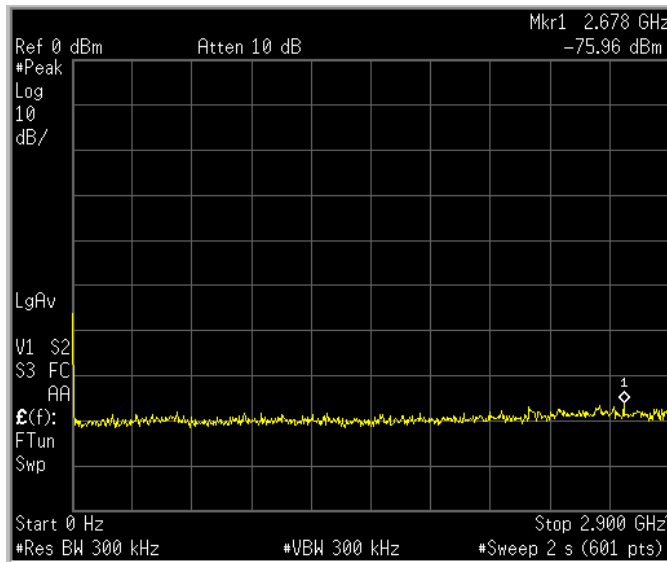

Stand-By

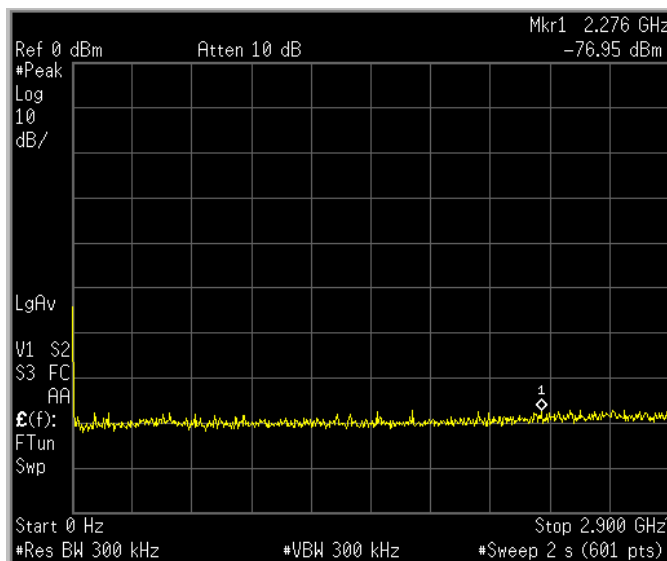

0.07 μ S Pulse

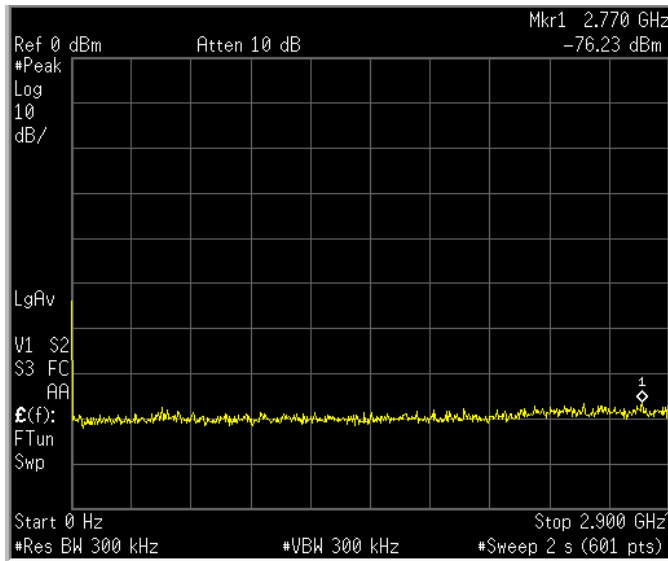

0.2 μ S Pulse

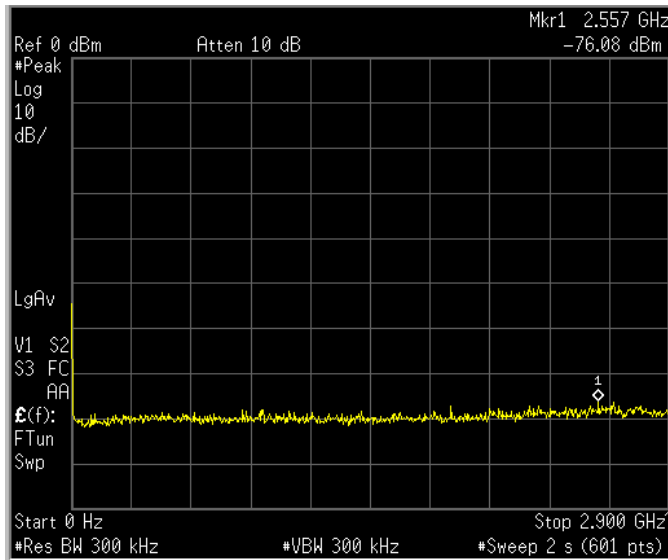

0.3 μ S Pulse

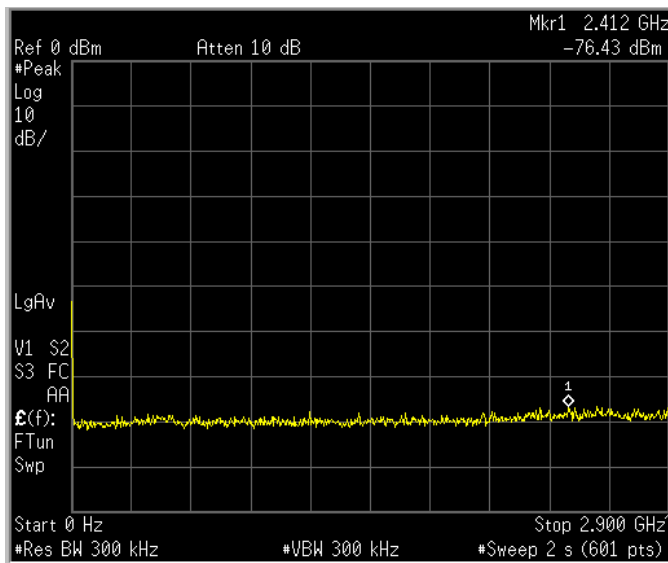

0.4 μ S Pulse

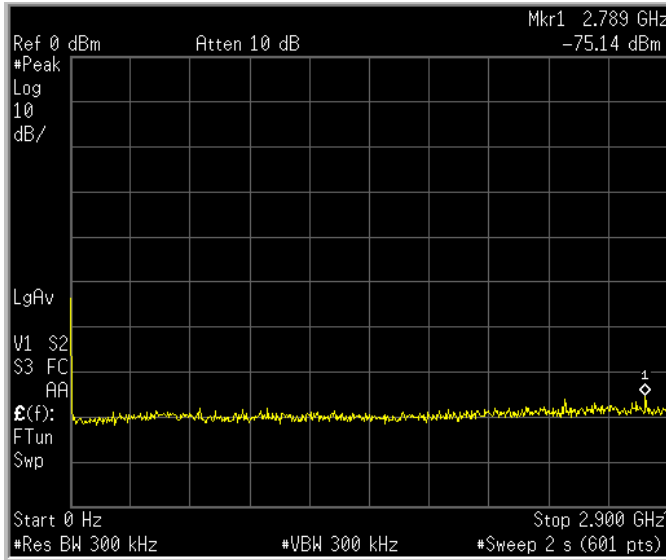

0.8 μ S Pulse

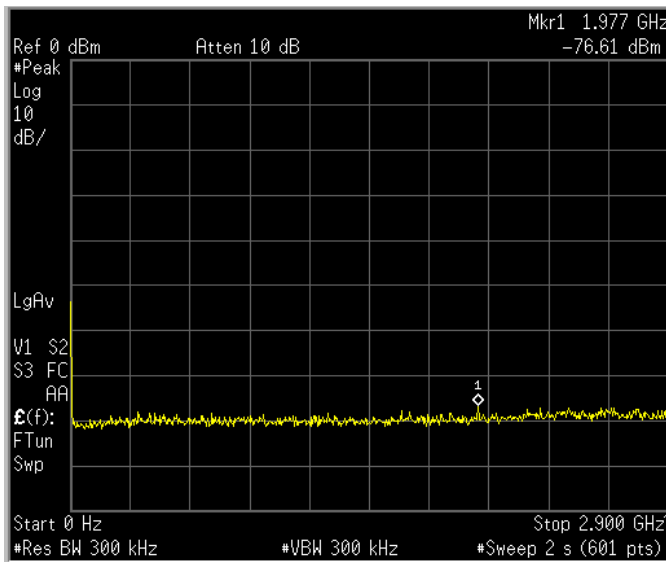

1.0 μ S Pulse

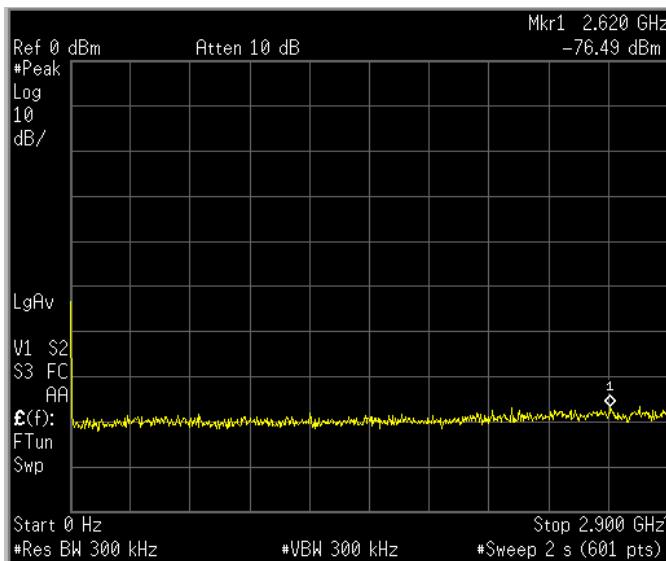

1.2 μ S Pulse

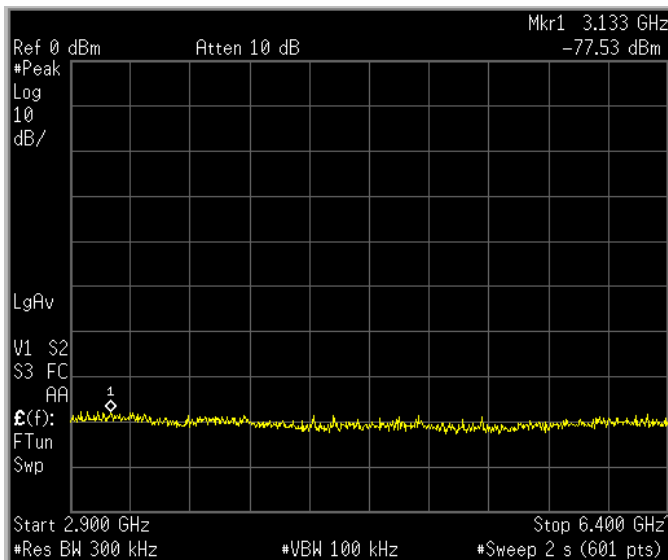

Ambient

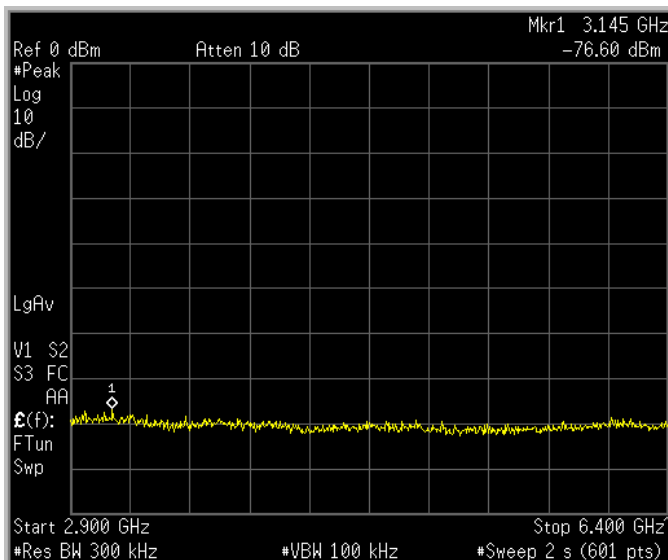

Stand-By

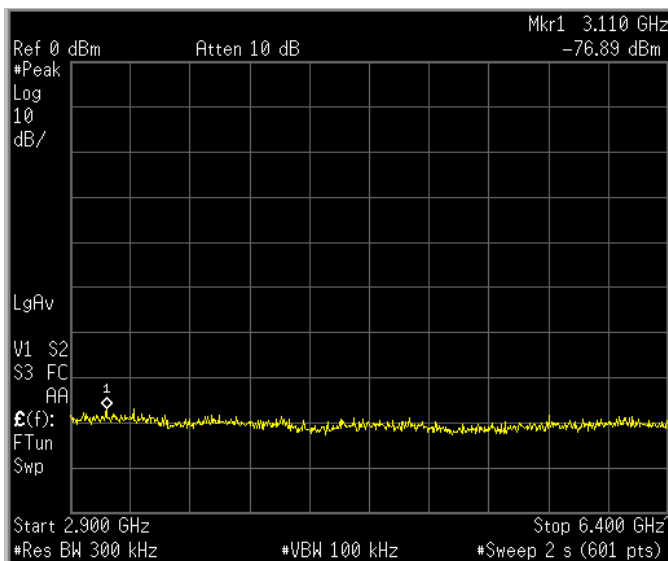

0.07 μ S Pulse

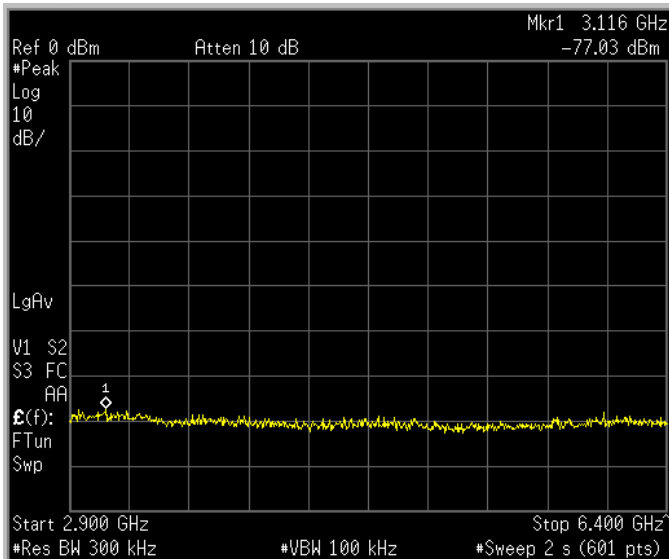

0.2 μ S Pulse

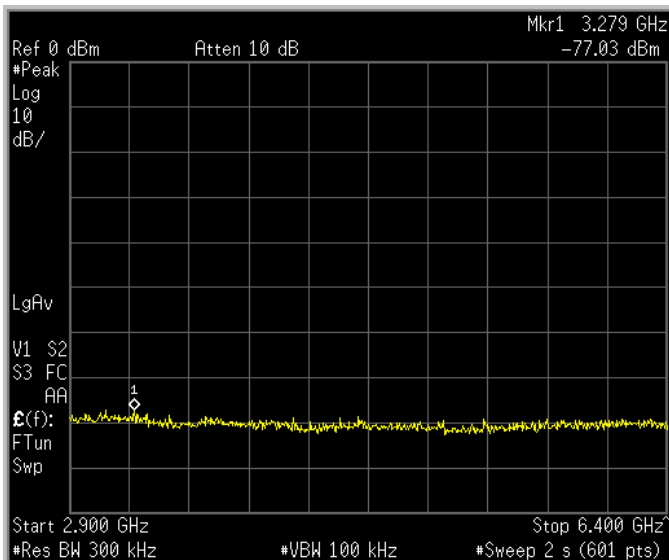

0.3 μ S Pulse

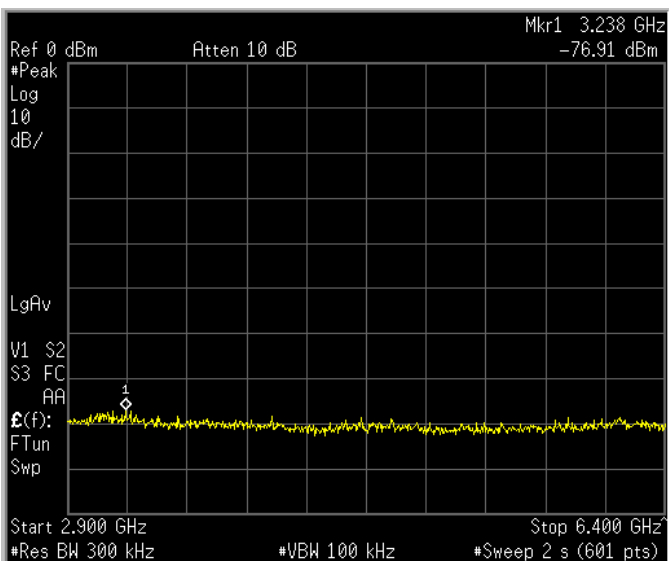

0.4 μ S Pulse

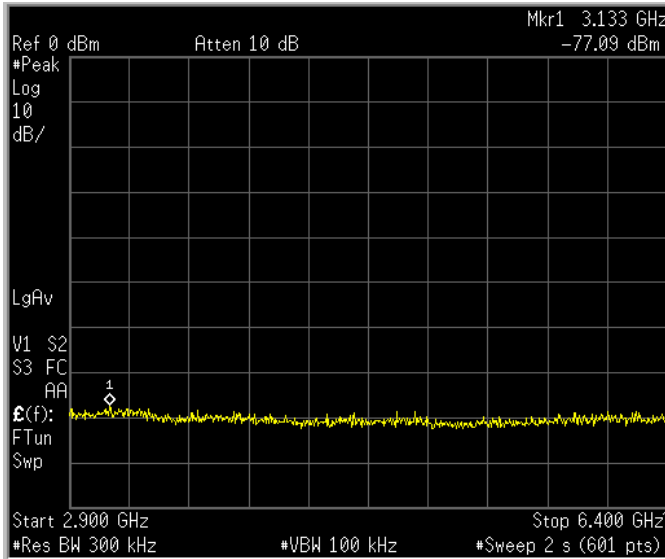

0.8 μ S Pulse

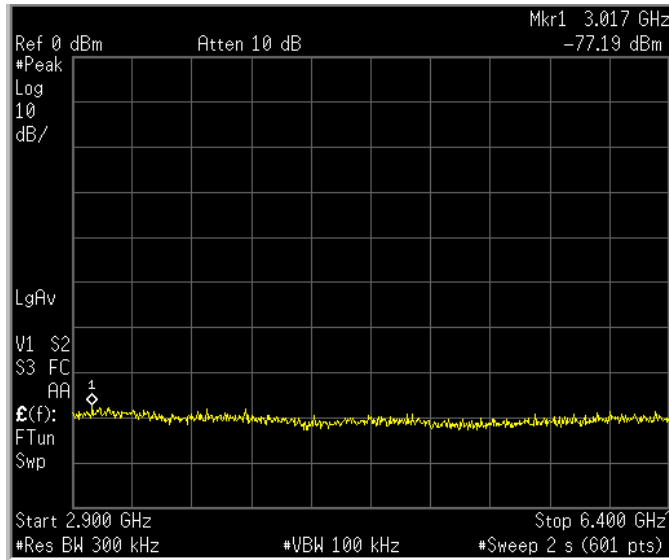

1.0 μ S Pulse

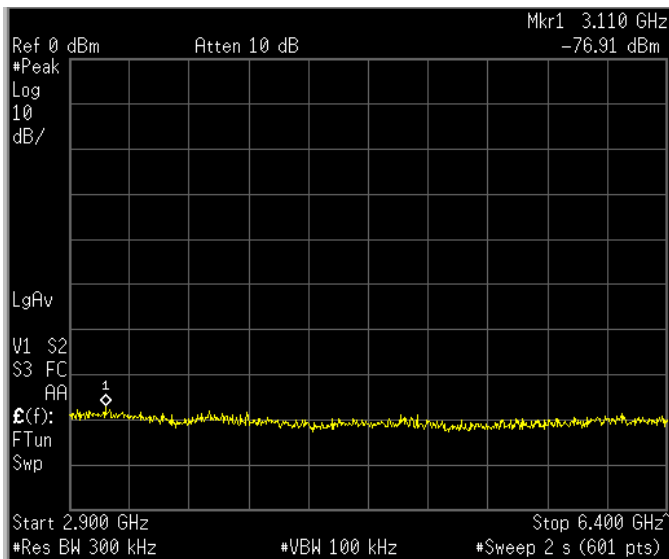

1.2 μ S Pulse

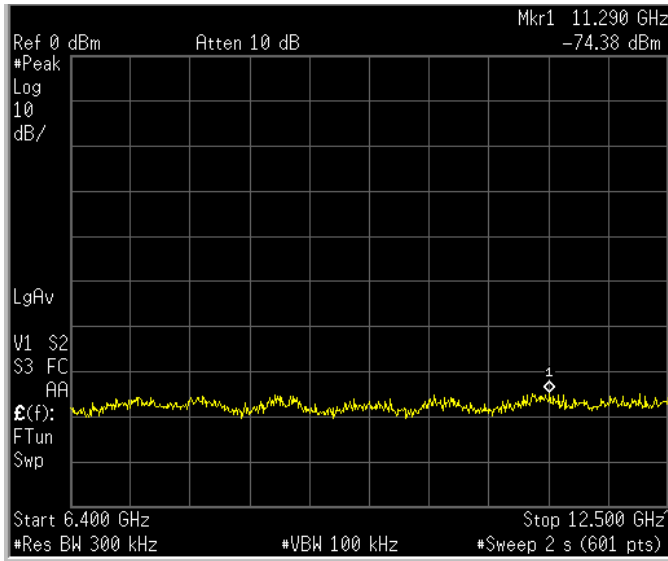

Ambient

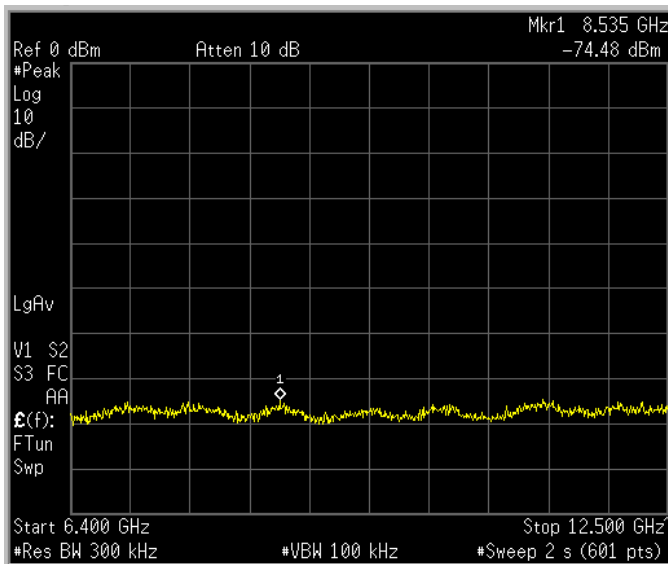

Stand-By

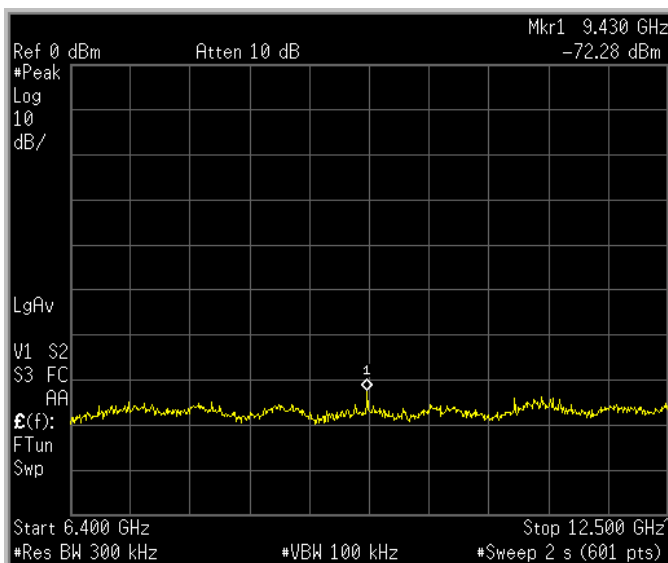

0.07 μ S Pulse

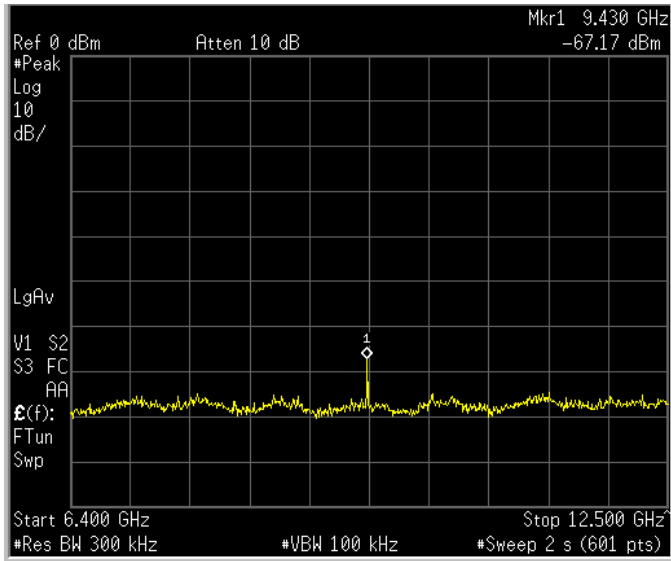

0.2 μ S Pulse

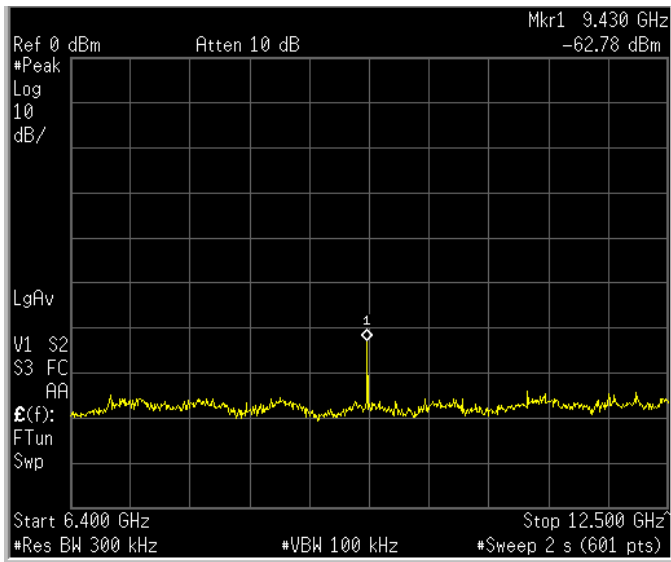

0.3 μ S Pulse

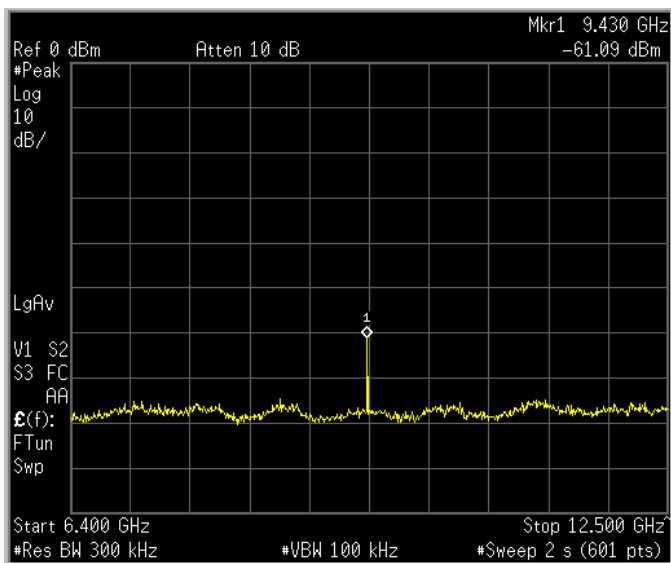

0.4 μ S Pulse

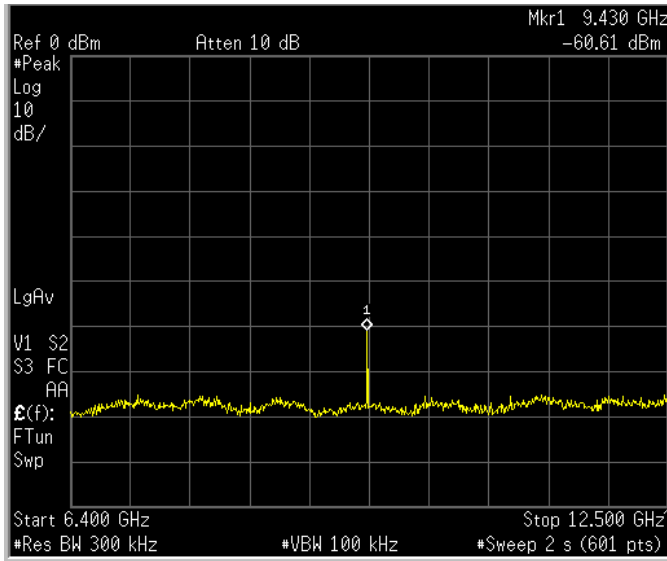

0.8 μ S Pulse

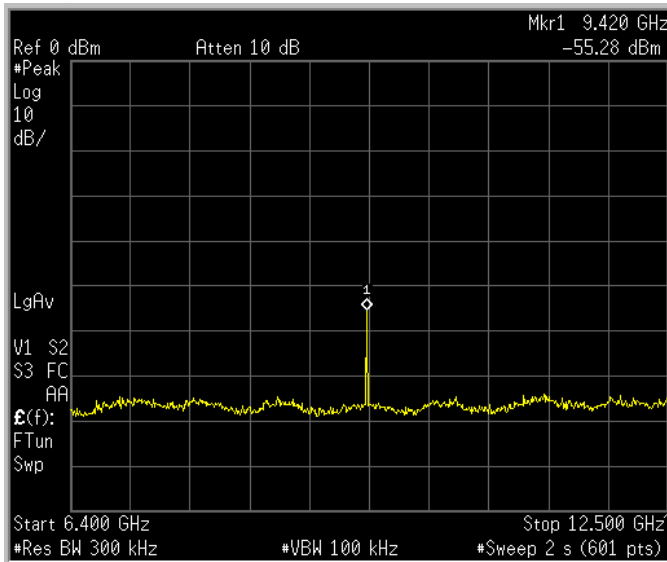

1.0 μ S Pulse

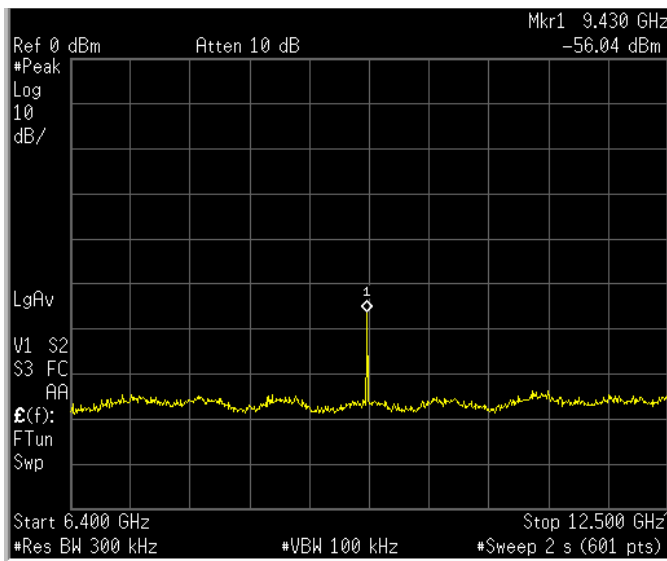

1.2 μ S Pulse

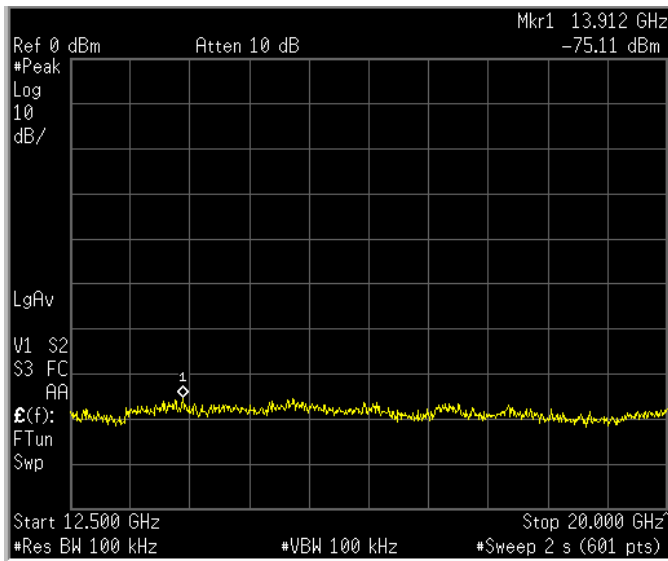

Ambient

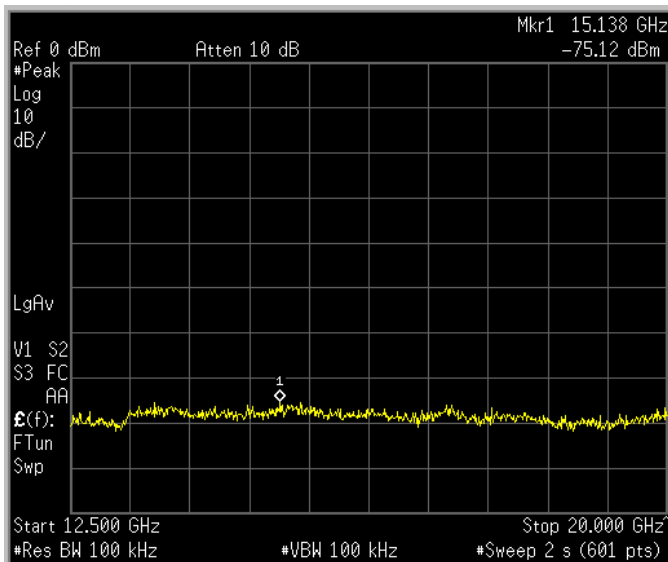

Stand-By

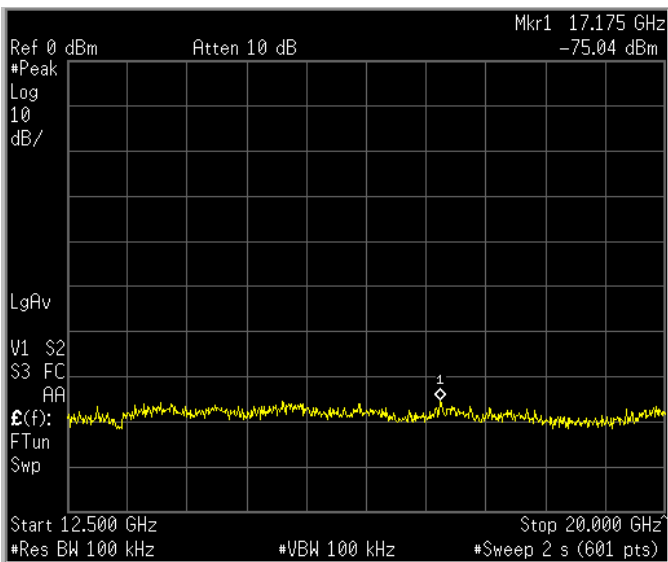

0.07 μ S Pulse

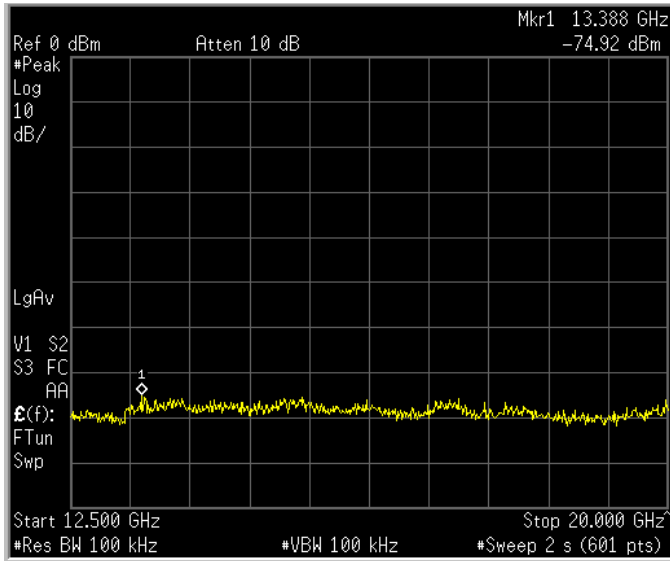

0.2 μ S Pulse

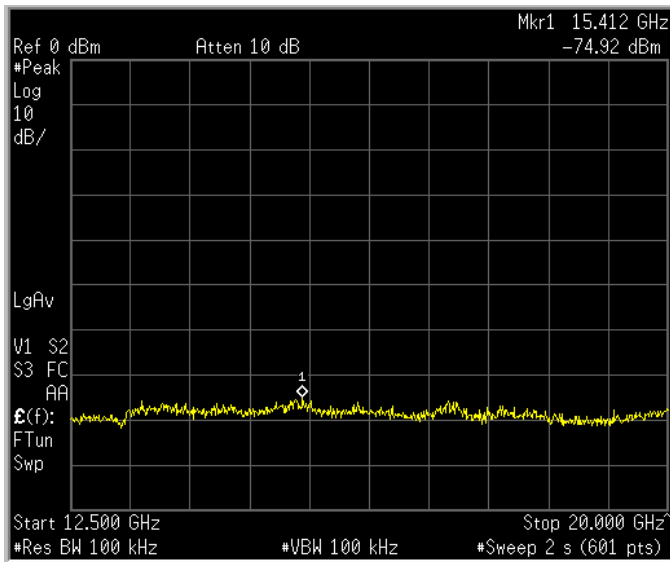

0.3 μ S Pulse

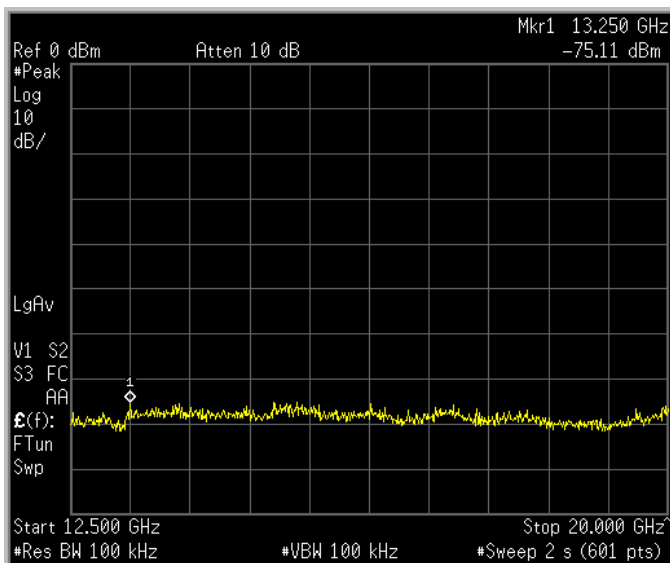

0.4 μ S Pulse

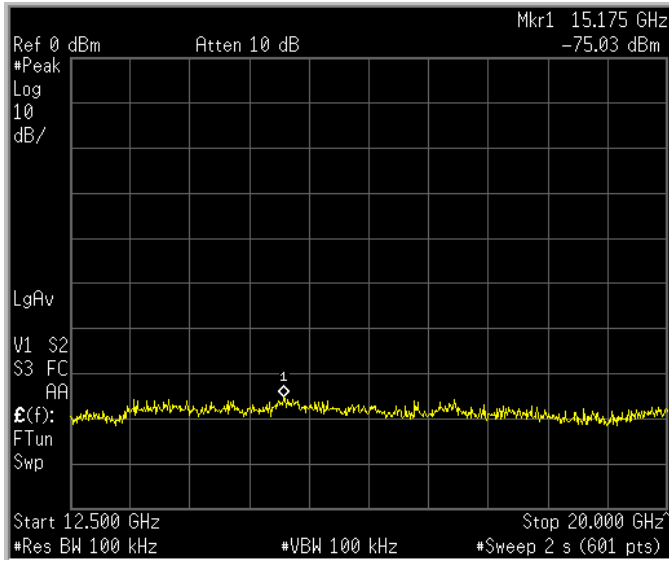

0.8 μ S Pulse

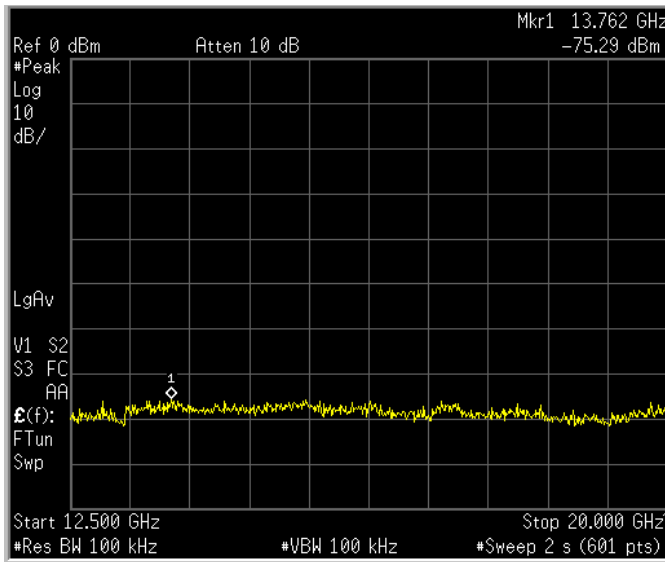

1.0 μ S Pulse

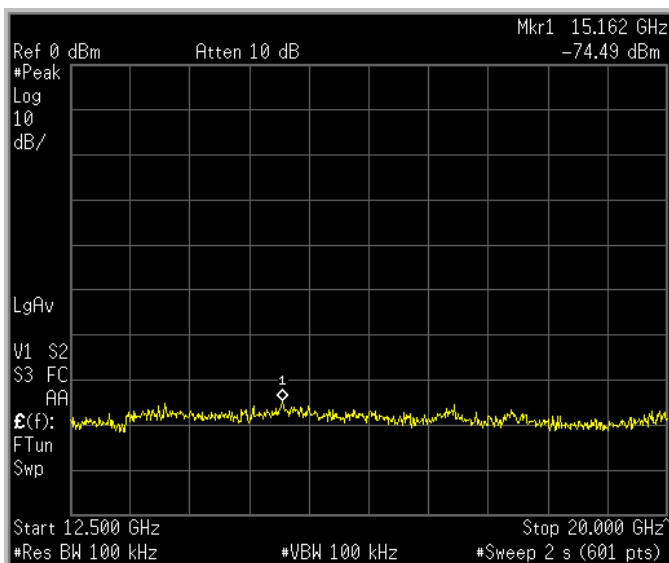

1.2 μ S Pulse

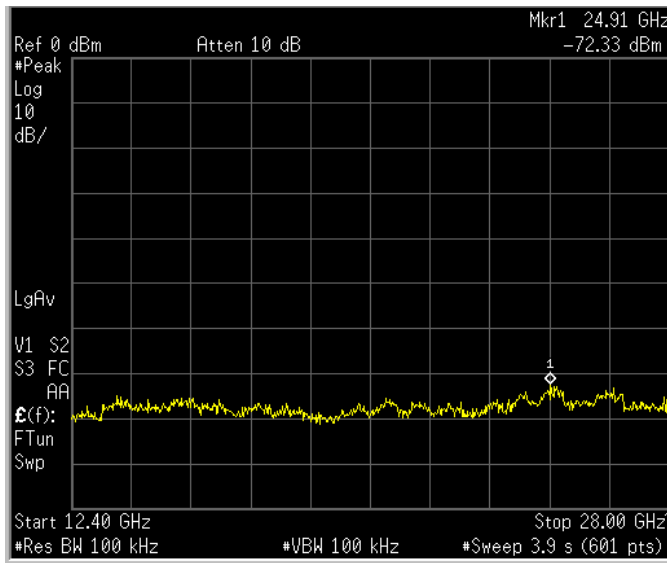

Ambient

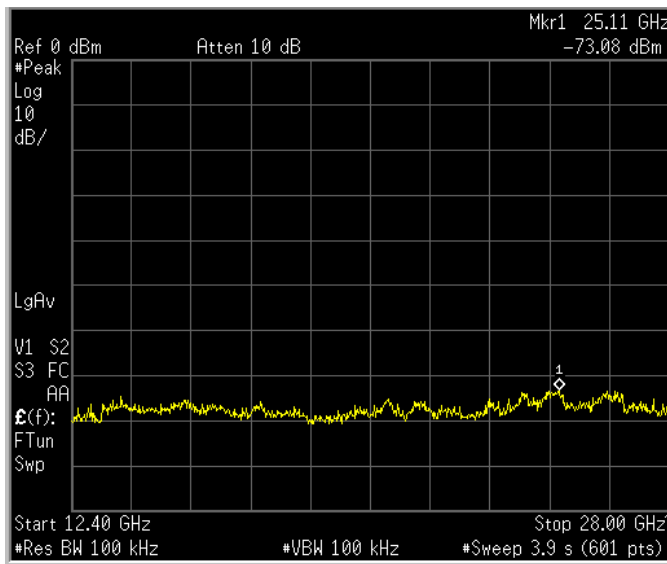

Stand-By

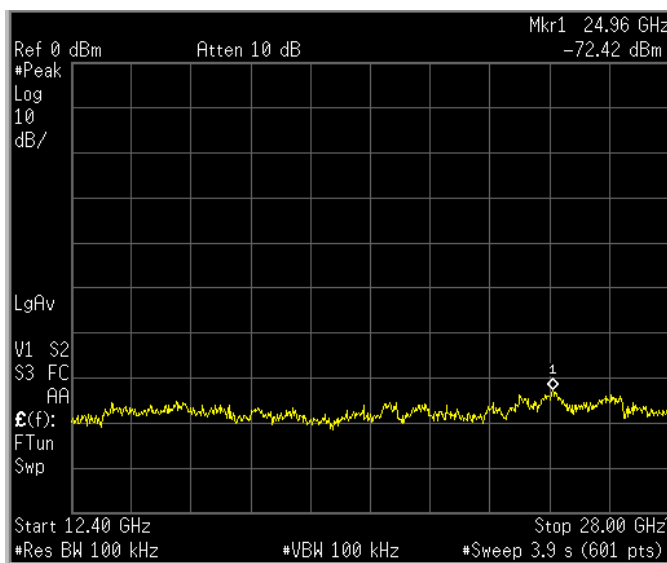

0.07 μ S Pulse

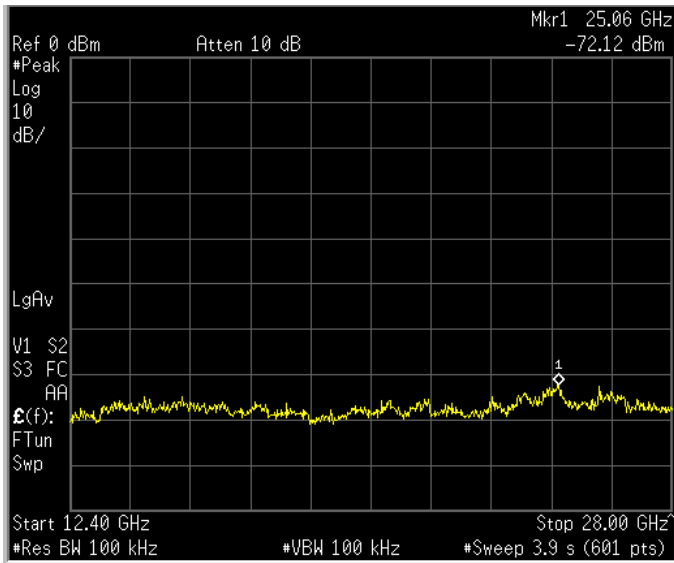

0.2 μ S Pulse

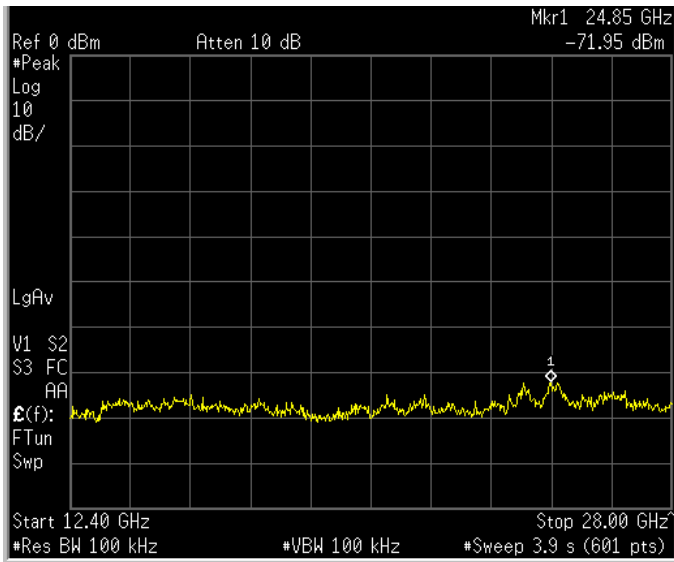

0.3 μ S Pulse

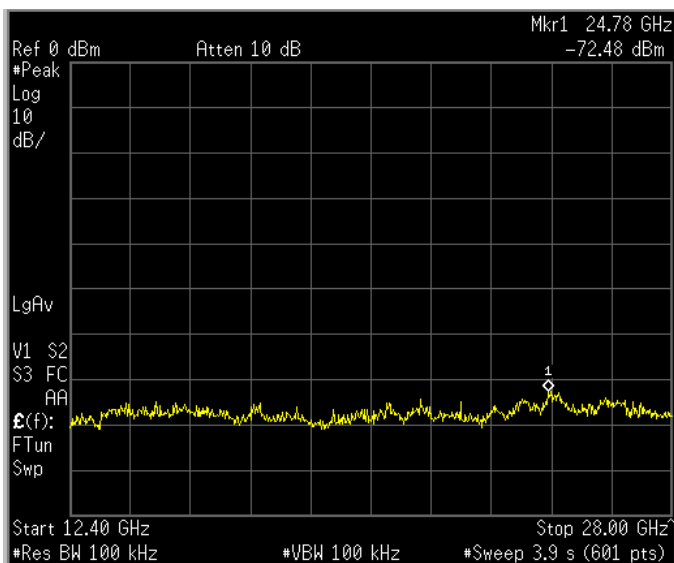

0.4 μ S Pulse

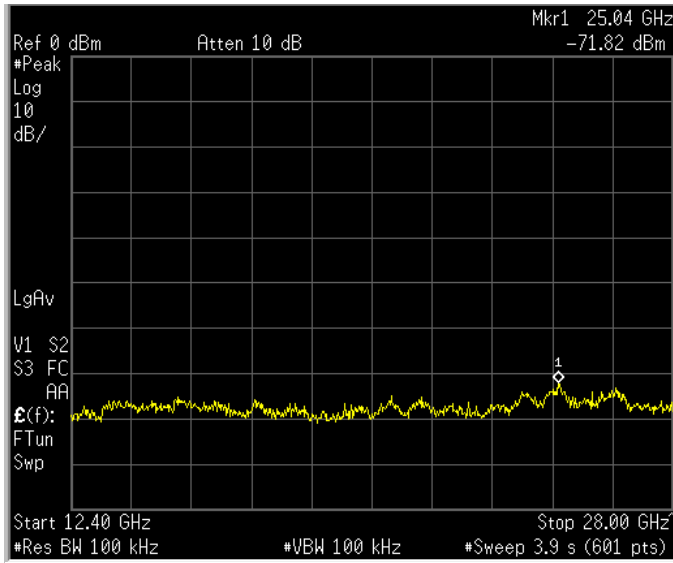

0.8 μ S Pulse

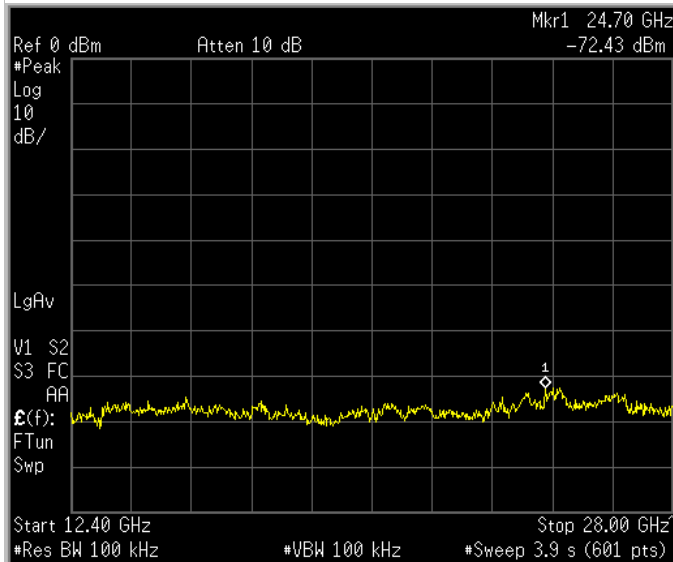

1.0 μ S Pulse

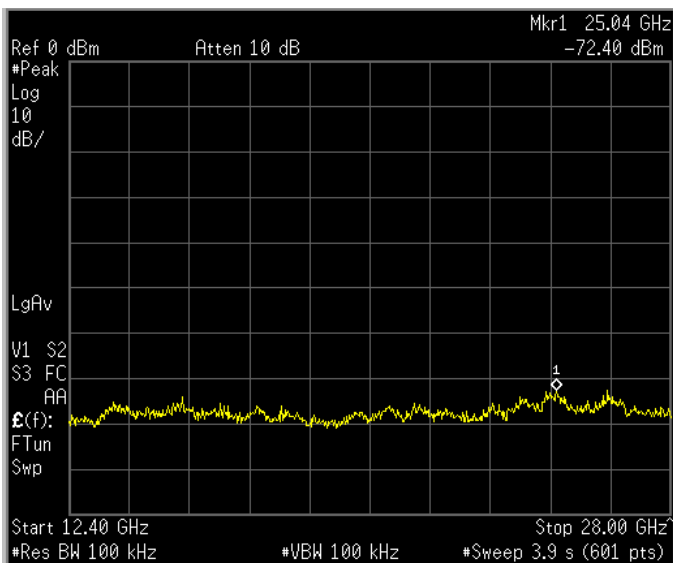

1.2 μ S Pulse

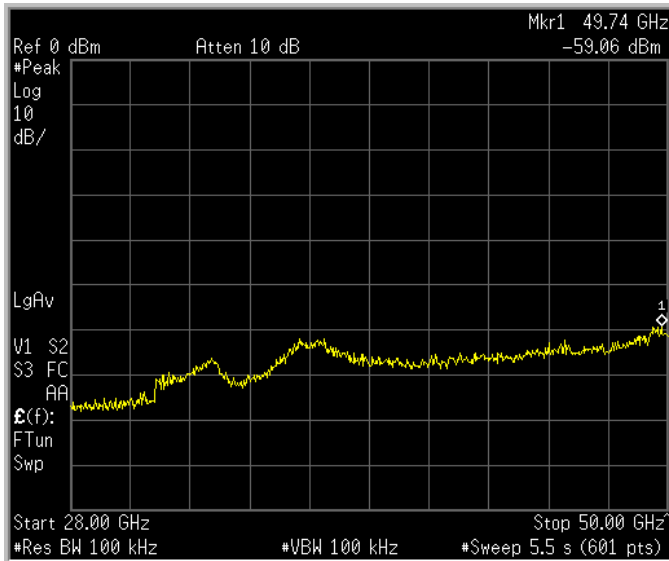

Ambient

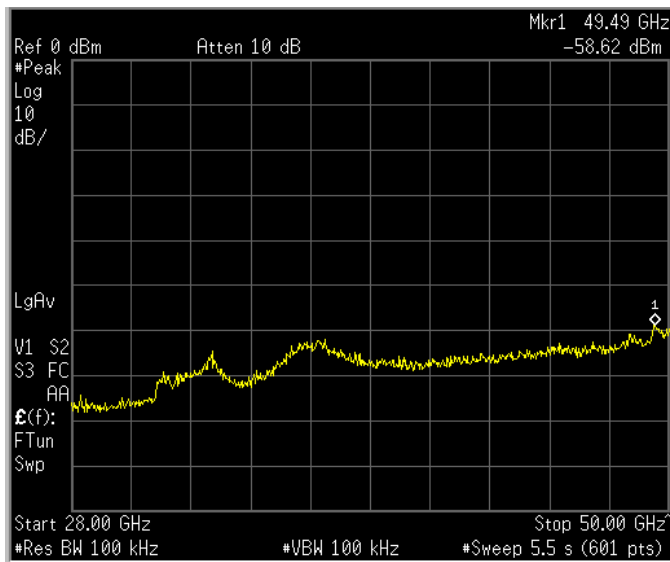

Stand-By

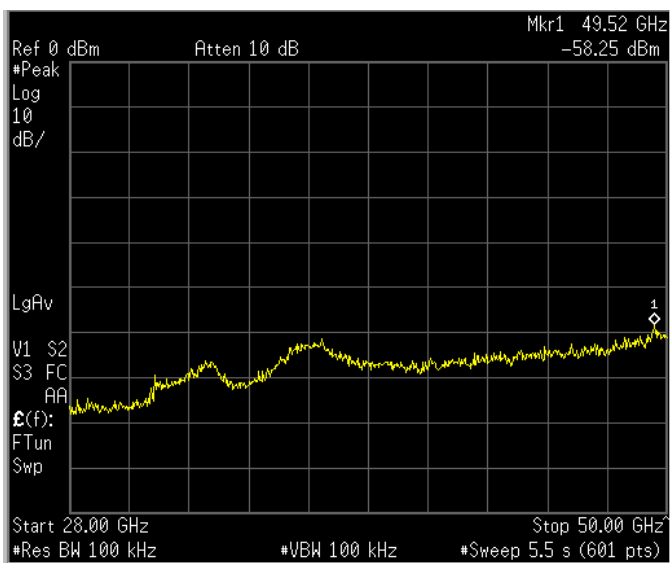

0.07 μ S Pulse

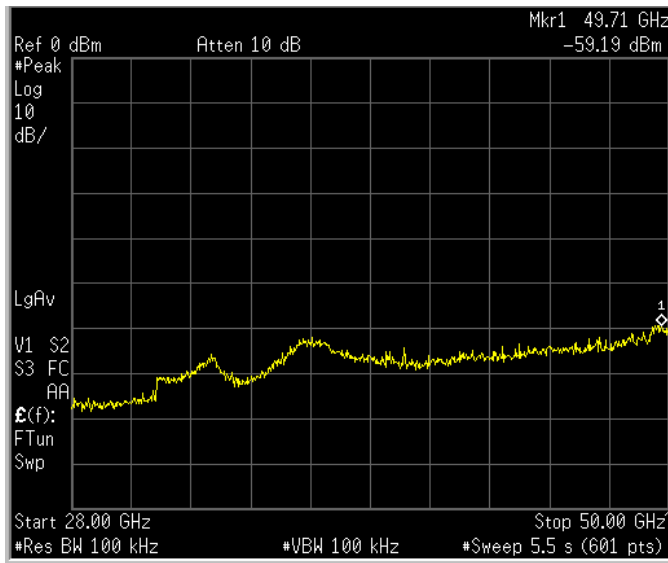

0.2 μ S Pulse

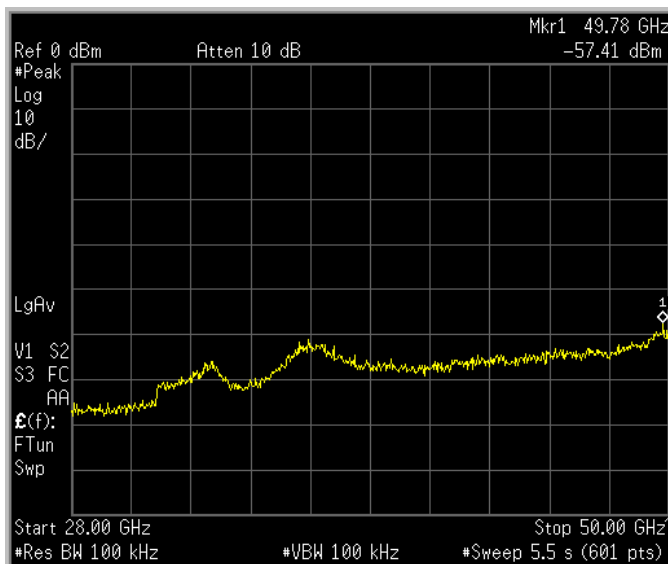

0.3 μ S Pulse

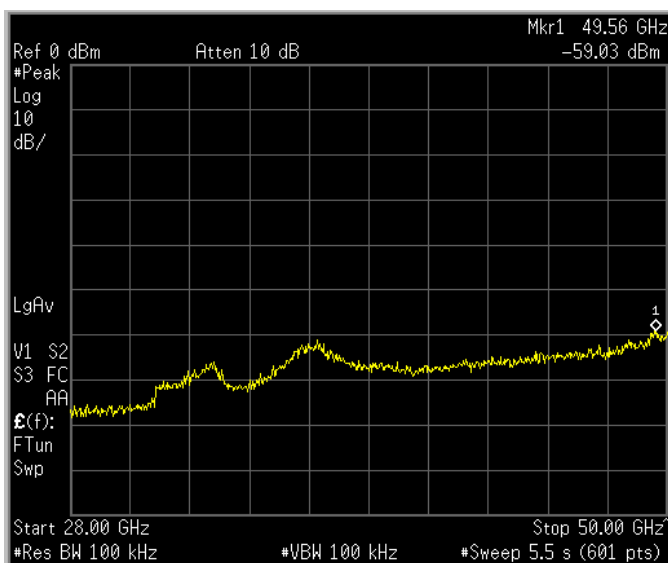

0.4 μ S Pulse

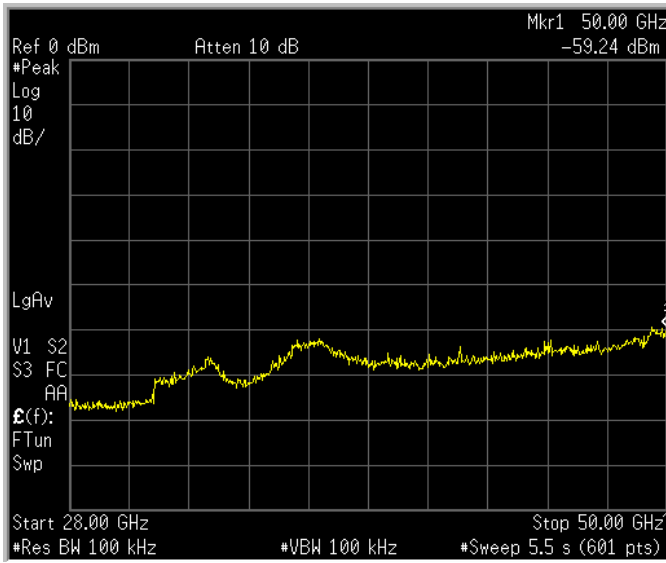

0.8 μ S Pulse

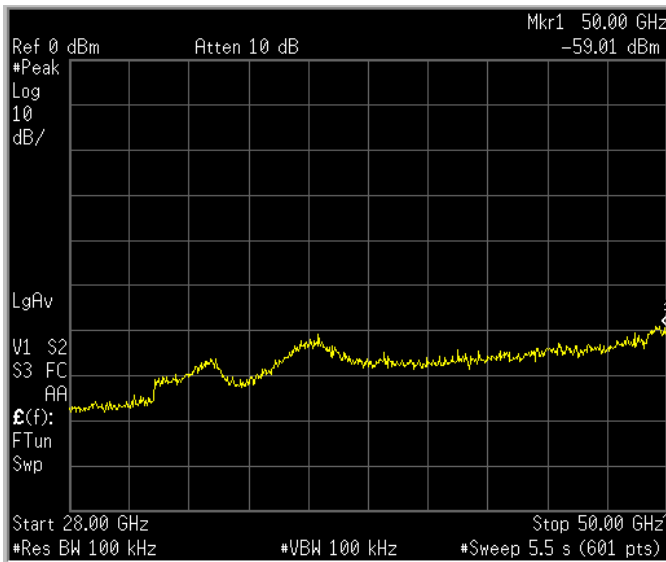

1.0 μ S Pulse

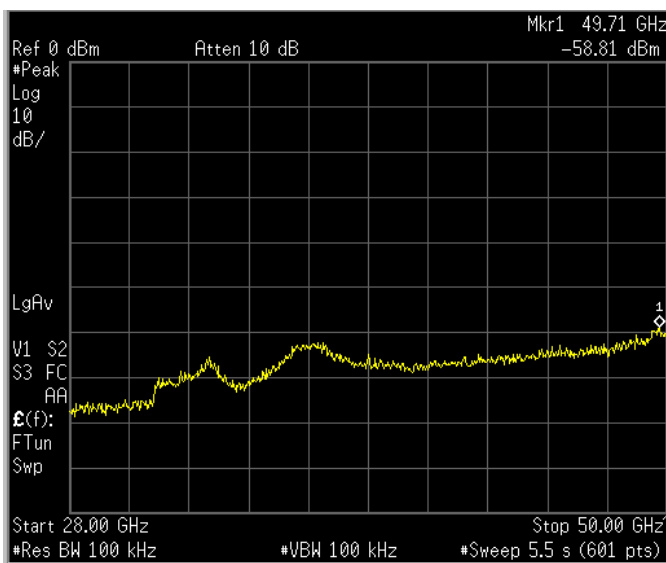

1.2 μ S Pulse