

TEST RESULT FOR FCC CERTIFICATION

Report Number : 7ZTJD0005

FCC ID : CKEJSS-2500

Purpose of test : Certify JSS-2500/JSS-2500N

Grantee's type or model No. : JSS-2500N (*1)

Drawing, specification or exhibit : FCC Part 2, 15 and 80

Quantity of item tested : One (1) of the above type

Abstract : Refer to result sections

Date tested completed : Aug 22, 2013

Test place : Japan Radio Co., Ltd.
Mitaka Plant
1-1, SHIMORENJAKU 5 CHOME,
MITAKA-SHI, TOKYO 181-8510,
JAPAN

(*1) : JSS-2500N (DSC/NBDP model) includes JSS-2500 (DSC Model),
so test equipment used JSS-2500N.

We, Japan Radio Company Limited, declare under our sole responsibility that the CKEJSS-2500 conforms to the CFR part 80 rules for MF/HF Radio Equipment.

Signed: Hideo Otsuki

Date: August 26, 2013

Hideo Otsuki
Manager
Network & Communication Group
Engineering Department
Marine Electronics Division

Signed: Shuji Furuta

Shuji Furuta
Network & Communication Group
Engineering Department
Marine Electronics Division

INDEX

1. General
2. Test for requirement
 - 2.1 RF power output and power amplifier operating parameters
 - 2.2 Modulation characteristics
 - 2.2.1 Frequency response of audio modulating circuit
 - 2.2.2 Modulation limiting characteristics
 - 2.2.3 Overall transmitter audio frequency response
 - 2.3 Occupied bandwidth
 - 2.4 Spurious emissions at antenna terminal
 - 2.5 Field strength of spurious radiation
 - 2.6 Frequency stability
 - 2.6.1 Frequency stability with temperature
 - 2.6.2 Frequency stability with primary supply voltage
 - 2.6.3 Frequency stability from cold start
 - 2.7 Interference

1. General

1.1 Normal test conditions

Power source	: 220V AC single phase 50Hz, or 24V DC
Temperature range	: +15°C to +30°C
Relative humidity	: 20% to 75%

1.2 Environmental test conditions

Power source

High voltage	: 253V AC (115%) 50Hz, 27.6V DC (115%)
Normal voltage	: 220V AC (100%) 50Hz, 24.0V DC (100%)
Low voltage	: 187V AC (85%) 50Hz, 20.4V DC (85%)

Temperature range

Low temperature	: -30°C
High temperature	: +50°C

1.3 Antenna impedance: 50 ohm

1.4 Modulation input impedance: 600 ohm

1.5 Equipment under test JSS-2500N block set up: Fig. 1.5

1.6 List of measurement instruments: Table 1.6

1.5 Equipment under test JSS-2500N block set up

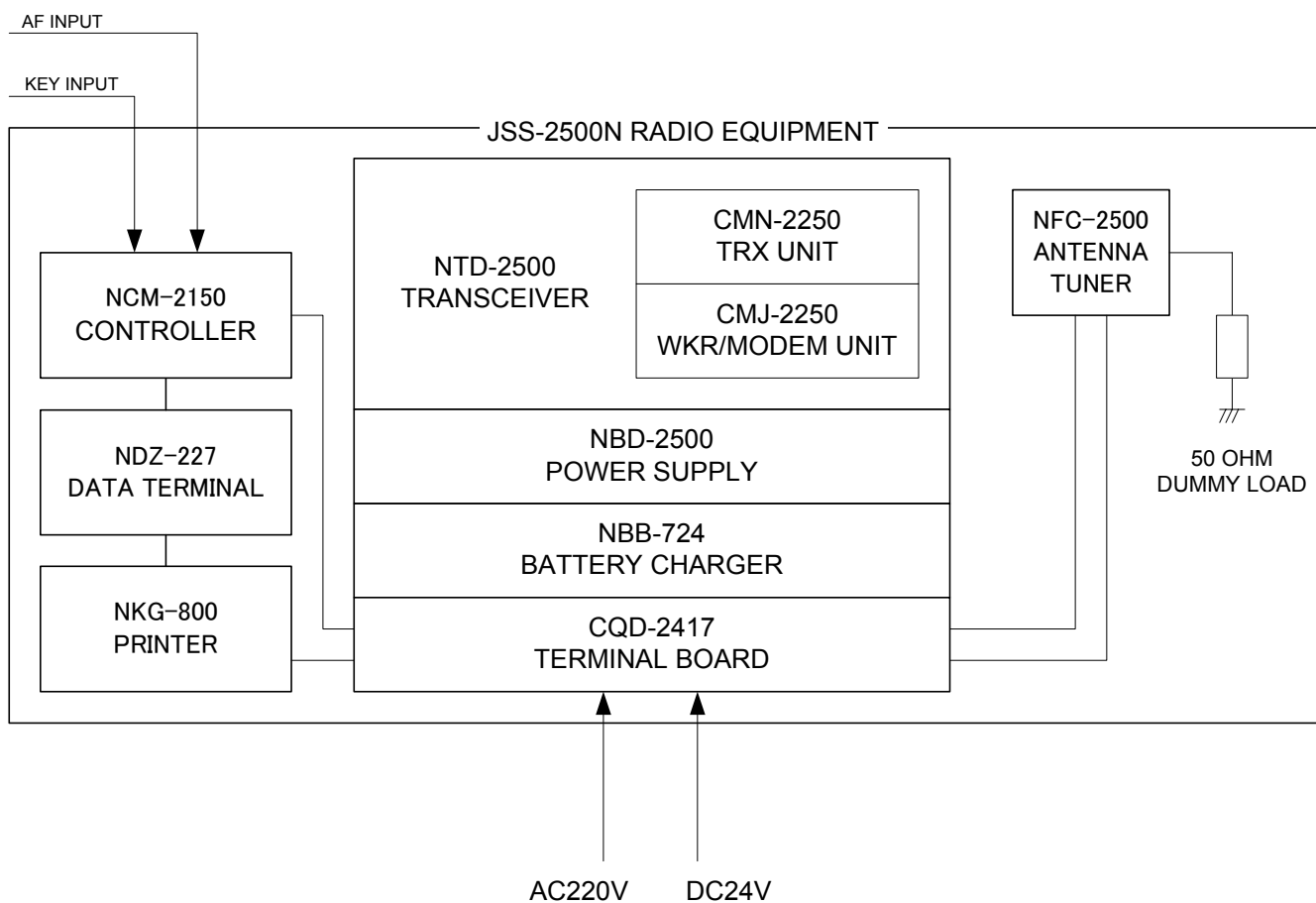

Fig. 1.5

1.6 List of measuring instruments

The measuring instruments used for these tests are maintained in good working condition and are calibrated on routine basis every six months.

Table 1.6

Article	Model	Serial No	Manufacturer	Calibration Date DD/MM/YY
AF Oscillator	796F	M-13748049	ShibaSoku	19/03/2013
AF Oscillator	AH87A	M-16034023	ShibaSoku	27/03/2013
AF Attenuator	STA-115	3074A	Tokyo KO-ON Denpa	08/01/2013
Bi-Directional coupler	4266	4381	Bird	20/12/2012
Wattmeter	TLP-52X	37109	FUJISOKU	08/01/2013
50 ohm dummy load	DL-102A-39-A	505714-1	Nihon Koushuuha	12/09/2012
Spectrum analyzer	8562E	3650A00306	HP	18/03/2013
Oscilloscope	475	-	Tektronix	14/02/2013
Frequency counter	TR5823H	-	ADVANTEST	13/02/2013
Attenuator	769-30	03579	Narda	27/03/2013
Dummy Load	908A	-	Agilent Technologies	26/03/2013

2. Test for requirement

2.1 RF power output and power amplifier operating parameters [FCC §2.1046(a),(b), §80.215(d)]

2.1.1 Test procedure

The Radio Equipment JSS-2500N was connected as shown in Fig. 2.1.1.

Output power: AC power supply --- 1.6 - 4MHz, 400W
4 - 27.5MHz, 500W

DC power supply --- 1.6 - 4MHz, 100W
4 - 27.5MHz, 150W

- (1) In AC power supply conditions: AC220V and $\pm 15\%$
The equipment was tested on each of marine bands in the transmitter frequency range with J3E, A1A and F1B (DSC and NBDP) modes, on the 2MHz marine band at three frequencies with J3E, A1A and F1B modes.
- (2) In DC power supply conditions: DC24V
The equipment was tested at three frequencies with J3E, A1A and F1B (DSC and NBDP) modes.

In J3E mode, test signals of 400Hz and 1800Hz are applied simultaneously to the microphone input. The levels of the tones were adjusted to produce equal output power. The level of the input signal increased until the transmitter rated output power, and then increased by 10dB as shown in Fig. 2.2.2.2 of the Modulation limiting characteristics test.

The transmission power in A1A mode was measured by continuous keying on.

In F1B mode, the continuous dot pattern modulated by the CMJ-2250 WKR MODEM unit is applied to the line input of the CMN-2250 TRX UNIT.

The current and voltage level of the final power amplifier were measured using the Ic/Vc menu of the NCM-2150 CONTROLLER. The AC and DC source voltages were measured at the power supply terminal.

The carrier suppression level without test signals was measured at this time with the spectrum analyzer.

According to the Recommendation ITU-R SM.326-7, the output power is calculated using the following formula.

$$\text{Output power} = \text{mean power} \times \left[\frac{\text{Deflection of oscilloscope at two-signal}}{\text{Deflection of oscilloscope at one signal}} \right]^2$$

(Watt)

2.1.2 Test results

Test results are as shown from Table 2.1.2-1 to Table 2.1.2-4.

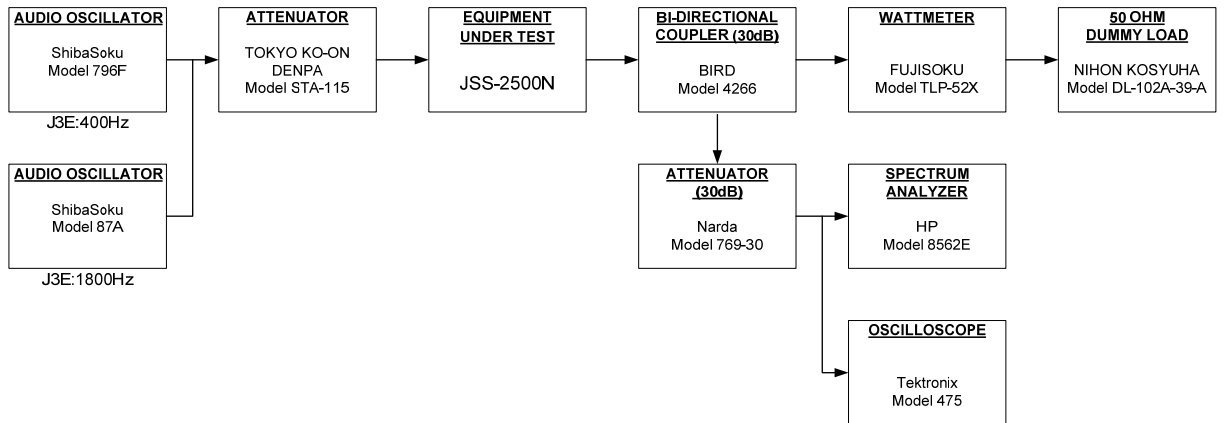

Fig. 2.1.1 Test set up for Power output and amplifier operating parameters

Table 2.1.2-1 Test results (AC220V)
RF power output and power amplifier operating parameters (cont'd)

(1/2)

Frequency (kHz)	Emission	Output (W)	Final Voltage (V)	Final Current (A)	Modulation	Modulation Level (V _{pep})	Carrier below pep (dB)
1619.0	J3E	376	120	9.1	2-Tone	0.004	----
		0	120	4.0	None	----	less than -80
	A1A	370	120	8.9	----	----	----
	F1B	375	120	9.1	Dot signal	2.2	----
2182.0	J3E	374	120	7.8	2-Tone	0.004	----
		0	120	4.0	None	----	less than -80
	A1A	360	120	7.6	----	----	----
	F1B	370	120	7.8	Dot signal	2.2	----
2187.5	J3E	372	120	7.8	2-Tone	0.004	----
		0	120	4.0	None	----	less than -80
	A1A	360	120	7.8	----	----	----
	F1B	375	120	7.8	Dot signal	2.2	----
2830.0	J3E	380	120	8.0	2-Tone	0.004	----
		0	120	4.0	None	----	less than -80
	A1A	370	120	8.0	----	----	----
	F1B	380	120	8.0	Dot signal	2.2	----
3258.0	J3E	388	120	8.9	2-Tone	0.004	----
		0	120	4.0	None	----	less than -80
	A1A	370	120	8.8	----	----	----
	F1B	380	120	8.9	Dot signal	2.2	----
4125.0	J3E	496	120	9.8	2-Tone	0.005	----
		0	120	4.0	None	----	less than -80
	A1A	490	120	9.6	----	----	----
	F1B	500	120	9.8	Dot signal	2.2	----
6215.0	J3E	500	120	9.8	2-Tone	0.005	----
		0	120	4.0	None	----	less than -80
	A1A	490	120	9.7	----	----	----
	F1B	505	120	9.8	Dot signal	2.2	----
8291.0	J3E	504	120	9.9	2-Tone	0.005	----
		0	120	4.0	None	----	less than -80
	A1A	500	120	9.9	----	----	----
	F1B	510	120	10.0	Dot signal	2.2	----
12290.0	J3E	499	120	9.5	2-Tone	0.005	----
		0	120	3.9	None	----	less than -80
	A1A	495	120	9.4	----	----	----
	F1B	500	120	9.6	Dot signal	2.2	----

Table 2.1.2-1 Test results (AC220V)

RF power output and power amplifier operating parameters (cont'd)

(2/2)

Frequency (kHz)	Emission	Output (W)	Final Voltage (V)	Final Current (A)	Modulation	Modulation Level (Vpep)	Carrier Below pep (dB)
16420.0	J3E	503	120	9.6	2-Tone	0.005	----
		0	120	3.9	None	----	less than -80
	A1A	490	120	9.5	----	----	----
	F1B	495	120	9.6	Dot signal	2.2	----
22177.0	J3E	496	120	9.9	2-Tone	0.005	----
		0	120	3.9	None	----	less than -80
	A1A	490	120	9.8	----	----	----
	F1B	500	120	9.9	Dot signal	2.2	----
26175.0	J3E	496	120	10.6	2-Tone	0.005	----
		0	120	3.9	None	----	less than -80
	A1A	495	120	10.5	----	----	----
	F1B	505	120	10.7	Dot signal	2.2	----

Table 2.1.2-2 Test results (AC187V)

RF power output and power amplifier operating parameters (cont'd)

(1/2)

Frequency (kHz)	Emission	Output (W)	Final Voltage (V)	Final Current (A)	Modulation	Modulation Level (V _{pep})	Carrier below pep (dB)
1619.0	J3E	376	120	9.1	2-Tone	0.004	----
		0	120	4.0	None	----	less than -80
	A1A	370	120	8.9	----	----	----
	F1B	375	120	9.1	Dot signal	2.2	----
2182.0	J3E	374	120	7.8	2-Tone	0.004	----
		0	120	4.0	None	----	less than -80
	A1A	360	120	7.6	----	----	----
	F1B	370	120	7.8	Dot signal	2.2	----
2187.5	J3E	372	120	7.8	2-Tone	0.004	----
		0	120	4.0	None	----	less than -80
	A1A	360	120	7.8	----	----	----
	F1B	375	120	7.8	Dot signal	2.2	----
2830.0	J3E	380	120	8.0	2-Tone	0.004	----
		0	120	4.0	None	----	less than -80
	A1A	370	120	8.0	----	----	----
	F1B	380	120	8.0	Dot signal	2.2	----
3258.0	J3E	388	120	8.9	2-Tone	0.004	----
		0	120	4.0	None	----	less than -80
	A1A	370	120	8.8	----	----	----
	F1B	380	120	8.9	Dot signal	2.2	----
4125.0	J3E	496	120	9.8	2-Tone	0.005	----
		0	120	4.0	None	----	less than -80
	A1A	490	120	9.6	----	----	----
	F1B	500	120	9.8	Dot signal	2.2	----
6215.0	J3E	500	120	9.8	2-Tone	0.005	----
		0	120	4.0	None	----	less than -80
	A1A	490	120	9.7	----	----	----
	F1B	505	120	9.8	Dot signal	2.2	----
8291.0	J3E	504	120	9.9	2-Tone	0.005	----
		0	120	4.0	None	----	less than -80
	A1A	500	120	9.9	----	----	----
	F1B	510	120	10.0	Dot signal	2.2	----
12290.0	J3E	499	120	9.5	2-Tone	0.005	----
		0	120	3.9	None	----	less than -80
	A1A	495	120	9.4	----	----	----
	F1B	500	120	9.6	Dot signal	2.2	----

Table 2.1.2-2 Test results (AC187V)

RF power output and power amplifier operating parameters (cont'd)

(2/2)

Frequency (kHz)	Emission	Output (W)	Final Voltage (V)	Final Current (A)	Modulation	Modulation Level (Vpep)	Carrier Below pep (dB)
16420.0	J3E	503	120	9.6	2-Tone	0.005	----
		0	120	3.9	None	----	less than -80
	A1A	490	120	9.5	----	----	----
	F1B	495	120	9.6	Dot signal	2.2	----
22177.0	J3E	496	120	9.9	2-Tone	0.005	----
		0	120	3.9	None	----	less than -80
	A1A	490	120	9.8	----	----	----
	F1B	500	120	9.9	Dot signal	2.2	----
26175.0	J3E	496	120	10.6	2-Tone	0.005	----
		0	120	3.9	None	----	less than -80
	A1A	495	120	10.5	----	----	----
	F1B	505	120	10.7	Dot signal	2.2	----

Table 2.1.2-3 Test results (AC253V)

RF power output and power amplifier operating parameters (cont'd)

(1/2)

Frequency (kHz)	Emission	Output (W)	Final Voltage (V)	Final Current (A)	Modulation	Modulation Level (Vpep)	Carrier below pep (dB)
1619.0	J3E	376	120	9.1	2-Tone	0.004	----
		0	120	4.0	None	----	less than -80
	A1A	370	120	8.9	----	----	----
	F1B	375	120	9.1	Dot signal	2.2	----
2182.0	J3E	374	120	7.8	2-Tone	0.004	----
		0	120	4.0	None	----	less than -80
	A1A	360	120	7.6	----	----	----
	F1B	370	120	7.8	Dot signal	2.2	----
2187.5	J3E	372	120	7.8	2-Tone	0.004	----
		0	120	4.0	None	----	less than -80
	A1A	360	120	7.8	----	----	----
	F1B	375	120	7.8	Dot signal	2.2	----
2830.0	J3E	380	120	8.0	2-Tone	0.004	----
		0	120	4.0	None	----	less than -80
	A1A	370	120	8.0	----	----	----
	F1B	380	120	8.0	Dot signal	2.2	----
3258.0	J3E	388	120	8.9	2-Tone	0.004	----
		0	120	4.0	None	----	less than -80
	A1A	370	120	8.8	----	----	----
	F1B	380	120	8.9	Dot signal	2.2	----
4125.0	J3E	496	120	9.8	2-Tone	0.005	----
		0	120	4.0	None	----	less than -80
	A1A	490	120	9.6	----	----	----
	F1B	500	120	9.8	Dot signal	2.2	----
6215.0	J3E	500	120	9.8	2-Tone	0.005	----
		0	120	4.0	None	----	less than -80
	A1A	490	120	9.7	----	----	----
	F1B	505	120	9.8	Dot signal	2.2	----
8291.0	J3E	504	120	9.9	2-Tone	0.005	----
		0	120	4.0	None	----	less than -80
	A1A	500	120	9.9	----	----	----
	F1B	510	120	10.0	Dot signal	2.2	----
12290.0	J3E	499	120	9.5	2-Tone	0.005	----
		0	120	3.9	None	----	less than -80
	A1A	495	120	9.4	----	----	----
	F1B	500	120	9.6	Dot signal	2.2	----

Table 2.1.2-3 Test results (AC253V)

RF power output and power amplifier operating parameters (cont'd)

(2/2)

Frequency (kHz)	Emission	Output (W)	Final Voltage (V)	Final Current (A)	Modulation	Modulation Level (Vpep)	Carrier Below pep (dB)
16420.0	J3E	503	120	9.6	2-Tone	0.005	----
		0	120	3.9	None	----	less than -80
	A1A	490	120	9.5	----	----	----
	F1B	495	120	9.6	Dot signal	2.2	----
22177.0	J3E	496	120	9.9	2-Tone	0.005	----
		0	120	3.9	None	----	less than -80
	A1A	490	120	9.8	----	----	----
	F1B	500	120	9.9	Dot signal	2.2	----
26175.0	J3E	496	120	10.6	2-Tone	0.005	----
		0	120	3.9	None	----	less than -80
	A1A	495	120	10.5	----	----	----
	F1B	505	120	10.7	Dot signal	2.2	----

Table 2.1.2-4 Test results (DC24V)

RF power output and power amplifier operating parameters (cont'd)

(1/1)

Frequency (kHz)	Emission	Output (W)	Final Voltage (V)	Final Current (A)	Modulation	Modulation Level (Vpep)	Carrier below pep (dB)
2182.0	J3E	108	100	2.9	2-Tone	0.006	----
		0	100	1.5	None	----	less than -80
	A1A	104	100	2.9	----	----	----
	F1B	106	100	2.9	Dot signal	2.2	----
2187.5	J3E	104	100	2.9	2-Tone	0.006	----
		0	100	1.5	None	----	less than -80
	A1A	102	100	2.9	----	----	----
	F1B	103	100	2.9	Dot signal	2.2	----

2.2 Modulation characteristics

2.2.1 Frequency response of audio modulating circuit [FCC §2.1047(a)]

2.2.1.1 Test procedure

The Radio Equipment JSS-2500N was connected as shown in Fig. 2.2.1.1.

An audio oscillator was used to drive the JSS-2500N (NCM-2150) handset input. The output signal of the MIC amplifier varied from 60Hz to 10kHz (100Hz to 5kHz) was measured with the audio spectrum analyzer.

2.2.1.2 Test results

Test results are shown in Table 2.2.1.2 and Fig. 2.2.1.2.

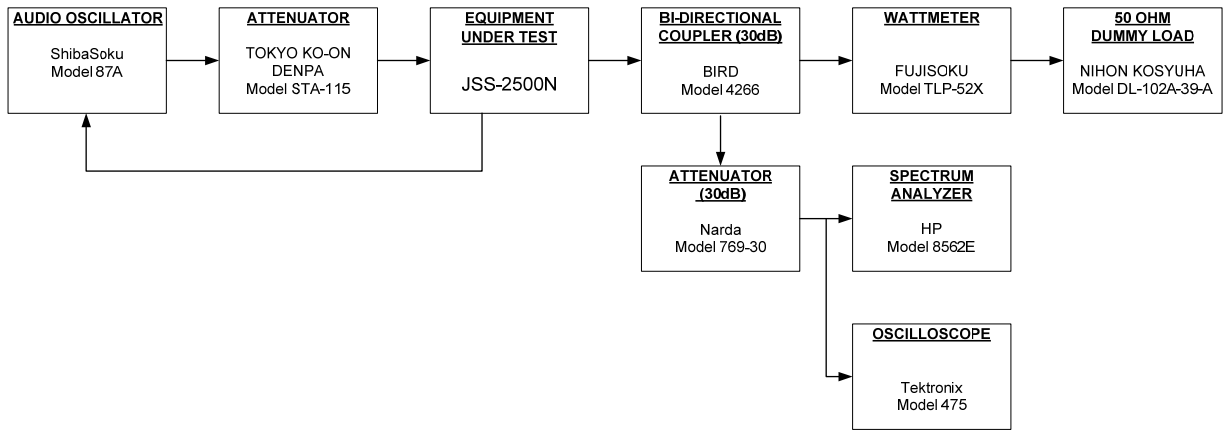

Fig. 2.2.1.1 Test set up for Frequency response of audio modulating circuit

Table 2.2.1.2 Frequency response of audio modulating circuit

Input Audio oscillator frequency (Hz)	Attenuation (dB)
60	-13.6
70	-11.2
80	-9.4
90	-8.2
100	-7.1
150	-4.4
200	-3.1
300	-1.7
400	-1.0
500	-0.6
750	-0.1
1000	0
1500	0
2000	-0.1
2500	-0.2
3000	-0.4
4000	-1.1
5000	-2.0
6000	-3.0
7000	-4.4
8000	-6.0
9000	-7.3
10000	-9.4

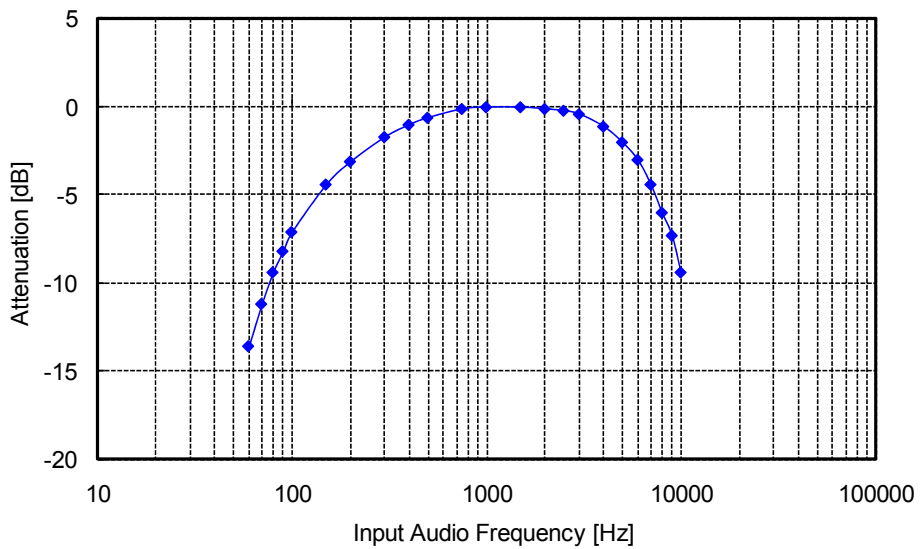

Fig 2.2.1.2 Frequency response of audio modulating circuit

2.2.2 Modulation limiting characteristics [FCC §2.1047(b), §80.213(a)(3)]

2.2.2.1 Test procedure

The Radio Equipment JSS-2500N was connected as shown in Fig. 2.2.2.1.

The modulation in J3E mode was signals of 400Hz and 1800Hz adjusted to produce equal output power.

The audio output voltage was measured with the oscilloscope, and the RF output power was measured with the oscilloscope.

2.2.2.2 Test results

Test results is shown in Table 2.2.2.2 and Fig. 2.2.2.2.

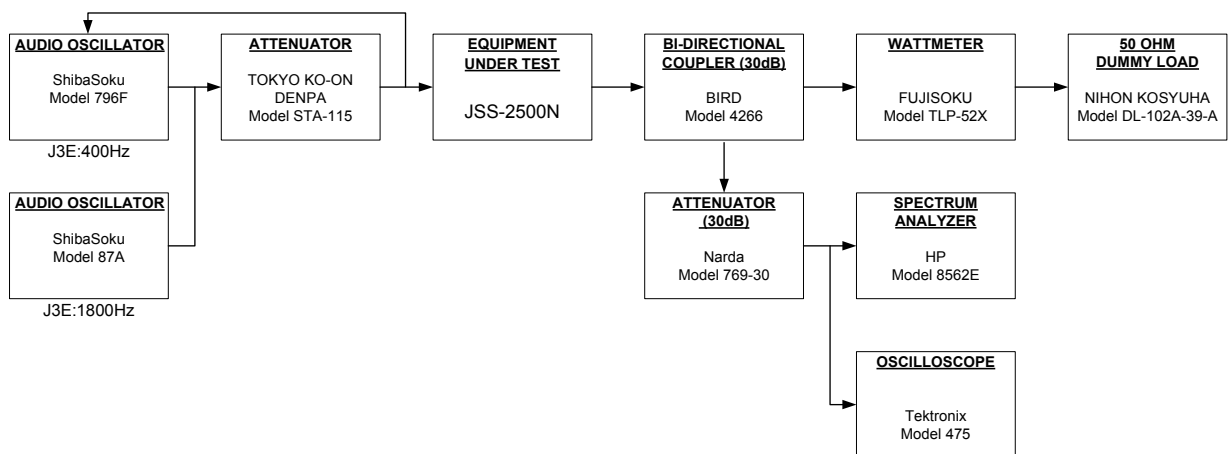

Fig. 2.2.2.1 Test set up for Modulation limiting characteristics

Table 2.2.2.2 Modulation limiting characteristics

Test frequency: 2182.0kHz

Mode: J3E

Line voltage: AC220V

Input level (mVrms)	RF output power (Wpep)
0.6	30
0.7	48
0.9	64
1.0	78
1.1	100
1.2	116
1.3	136
1.4	172
1.6	220
1.7	260
1.8	310
1.9	342
2.1	380
2.3	400
2.4	400
2.6	400
3.1	400
3.5	400
4.5	400
6.1	400
7.1	400
10.0	400

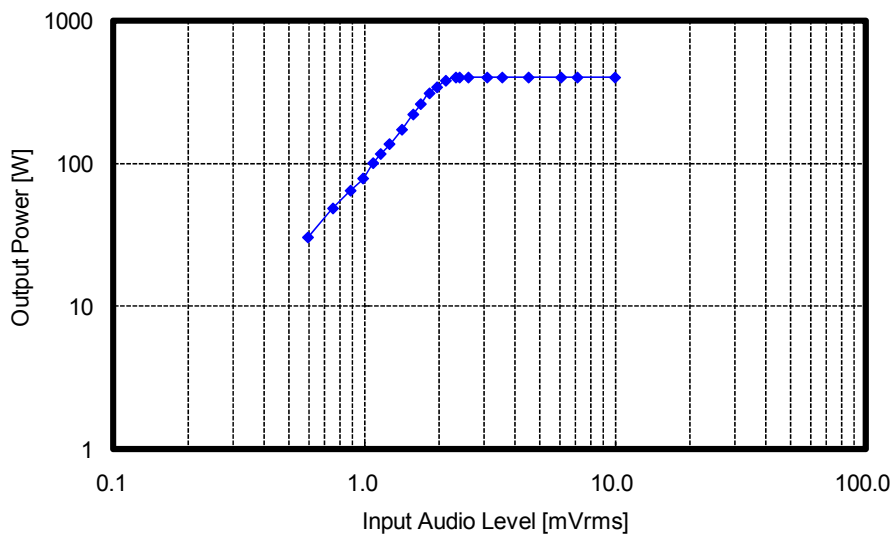

Fig 2.2.2.2 Modulation limiting characteristics

2.2.3 Overall transmitter audio frequency response [FCC §2.1047(c), 80.211(a)]

2.2.3.1 Test procedure

The Radio Equipment JSS-2500N was connected as shown in Fig. 2.2.3.1.

The overall transmitter audio response curve includes the audio response of the complete transmitter from handset input to power output. The level of test signal varied from 50Hz to 10kHz adjusted so that the output power at the peak response characteristic was 10dB below the rated output power. The peak response was measured with the spectrum analyzer.

2.2.3.2 Test results

Test results are shown in Table 2.2.3.2 and Fig. 2.2.3.2.

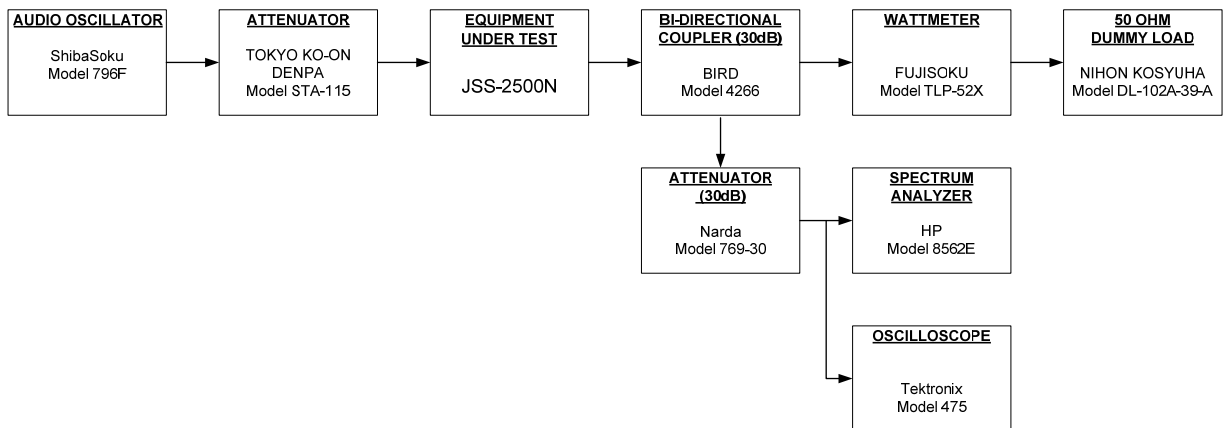
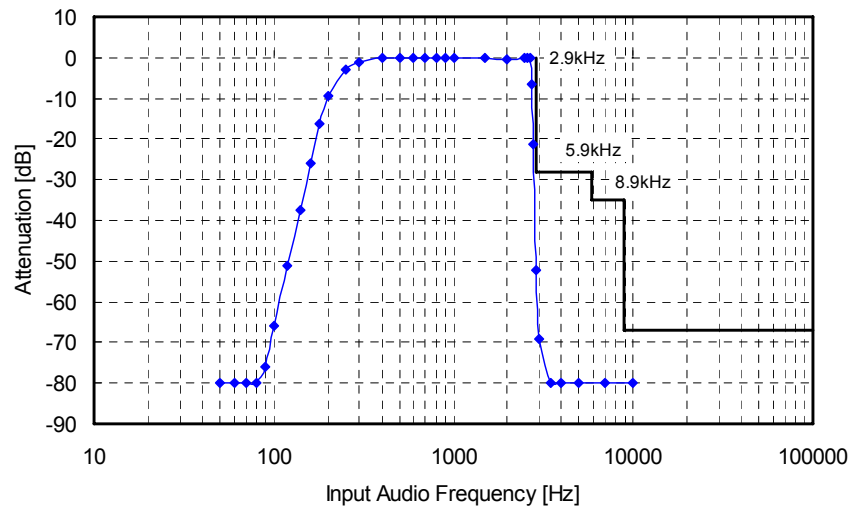

Fig. 2.2.3.1 Test set up for Overall transmitter audio frequency response

Table 2.2.3.2 Overall transmitter audio frequency response

Input Audio oscillator frequency (Hz)	Attenuation (dB)
50	less than -80.0
60	less than -80.0
70	less than -80.0
80	less than -80.0
90	-75.6
100	-66.0
120	-50.0
140	-38.0
160	-25.0
180	-15.0
200	-9.3
250	-2.8
300	-1.0
400	-0.1
500	-0.1
600	0.0
700	-0.2
800	-0.2
900	-0.2
1000	-0.2
1500	-0.3
2000	-0.3
2500	-0.2
2600	-0.2
2700	-0.3
2750	-6.8
2800	-22.2
2900	-53.5
3000	-70.2
3500	less than -80.0
4000	less than -80.0
5000	less than -80.0
7000	less than -80.0
10000	less than -80.0



2.3 Occupied bandwidth

[FCC §2.1049(a),(c)(2), §80.205(a), §80.211(a),(f)]

2.3.1 Test procedure

The Radio Equipment JSS-2500N was connected as shown in Fig. 2.3.1.

The transmitter was modulated with signals of 400Hz and 1800Hz for J3E mode, with 16 dots per second for A1A mode, with continuous dot pattern for F1B mode.

The J3E modulation level was shown in Fig. 2.2.2.2 of the Modulation limiting characteristics. The J3E audio input level was constant at 10dB over the rated output power as per §2.1047(c). The spectrum analyzer was adjusted so that mean power was at the reference.

The equipment was tested on each of marine bands in the transmitter frequency range with J3E, A1A and F1B modes, on the 2MHz marine band at two frequencies with J3E, A1A and F1B modes.

2.3.2 Test results

Test results are shown from Fig. 2.3.2-1 to Fig. 2.3.2-42.

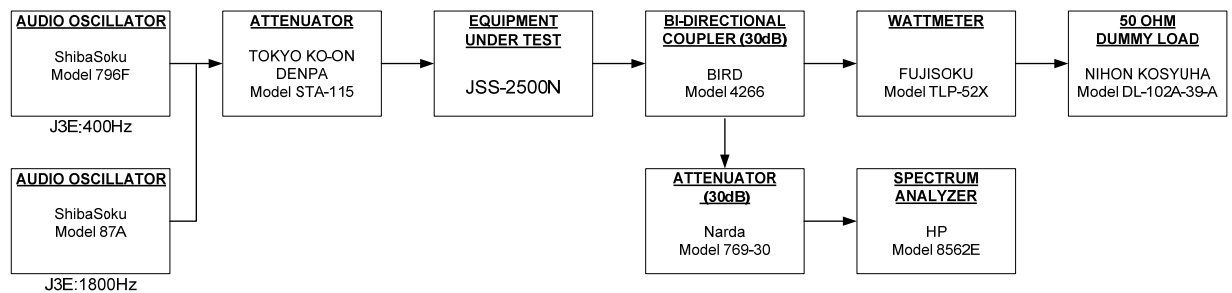

Fig. 2.3.1 Test set up for Occupied bandwidth

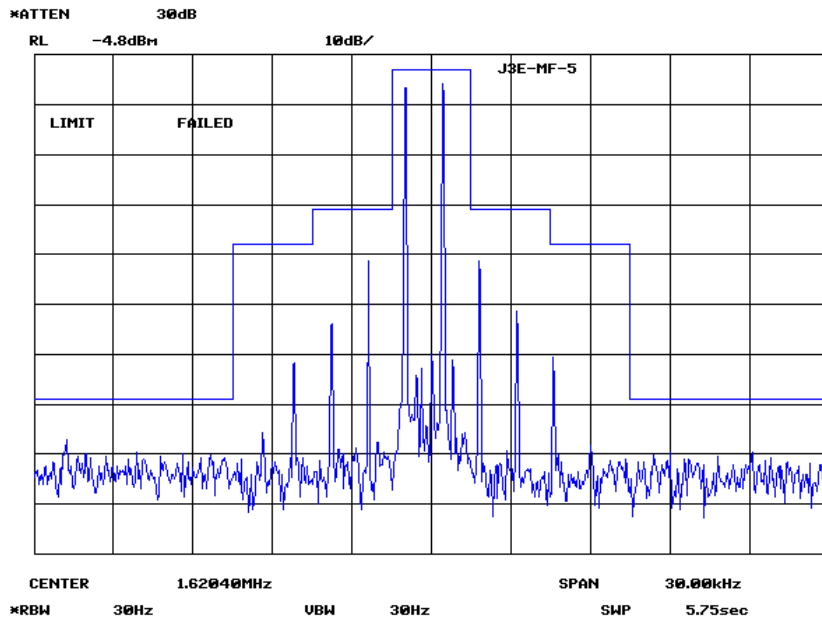

Fig. 2.3.2-1 Occupied bandwidth
Frequency : 1.619 MHz
Mode : J3E
Line Voltage : AC220V

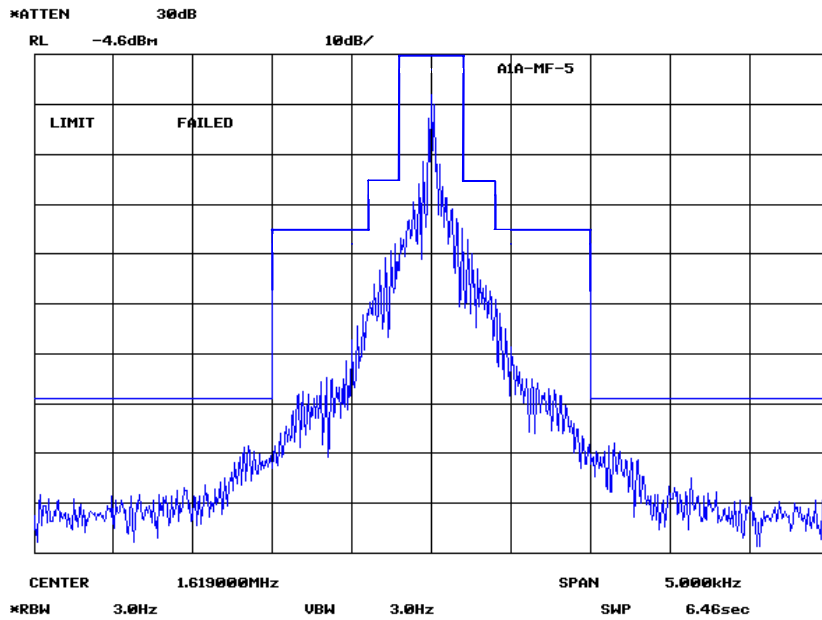

Fig. 2.3.2-2 Occupied bandwidth
Frequency : 1.619 MHz
Mode : A1A
Line Voltage : AC220V

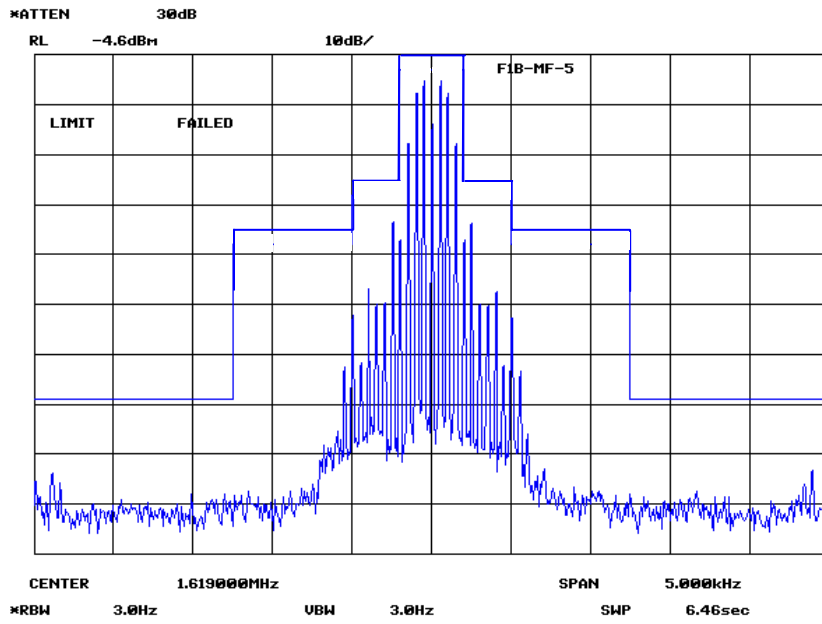

Fig. 2.3.2-3 Occupied bandwidth
Frequency:1619.0kHz
Mode:F1B
Line Voltage:AC220V

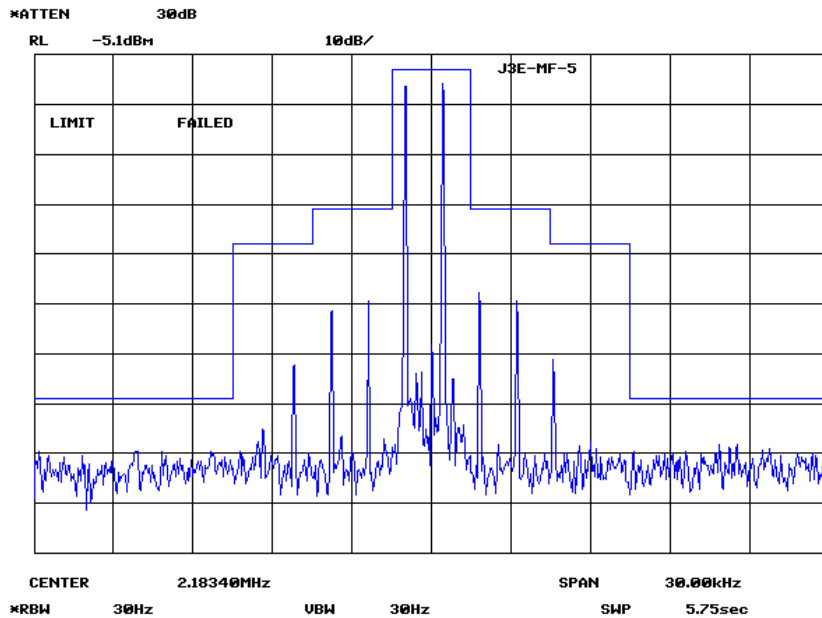

Fig. 2.3.2-4 Occupied bandwidth
Frequency:2182.0kHz
Mode:J3E
Line Voltage:AC220V

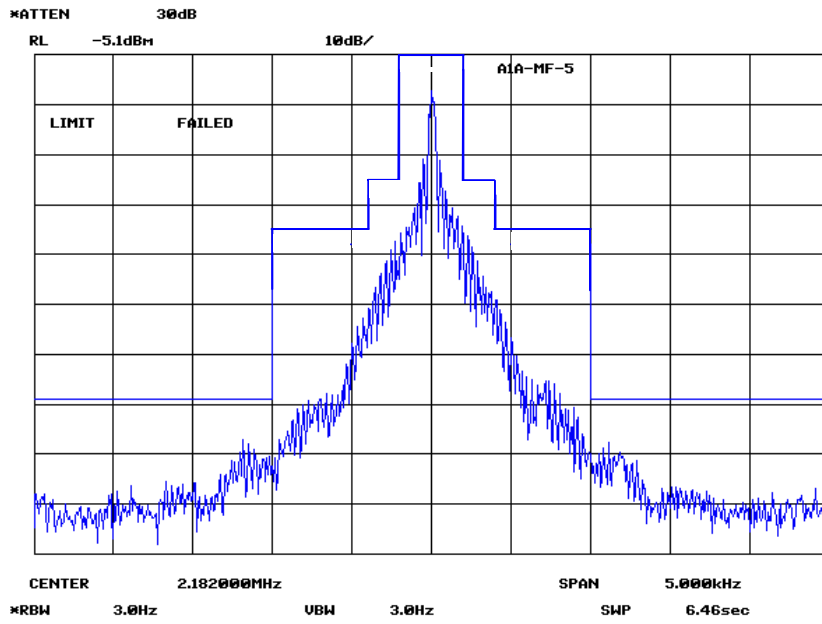

Fig. 2.3.2-5 Occupied bandwidth
Frequency:2182.0kHz
Mode:A1A
Line Voltage:AC220V

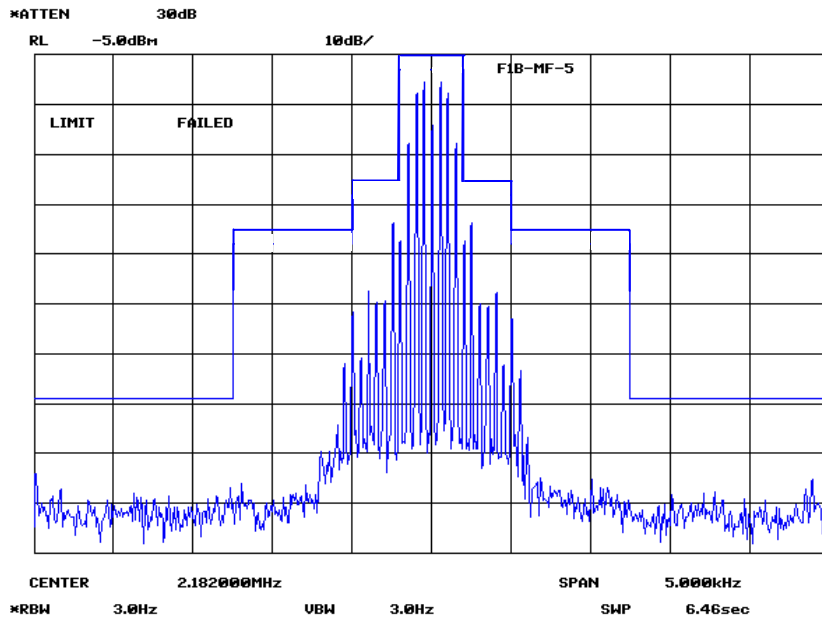

Fig. 2.3.2-6 Occupied bandwidth
Frequency:2182.0kHz
Mode:F1B
Line Voltage:AC220V

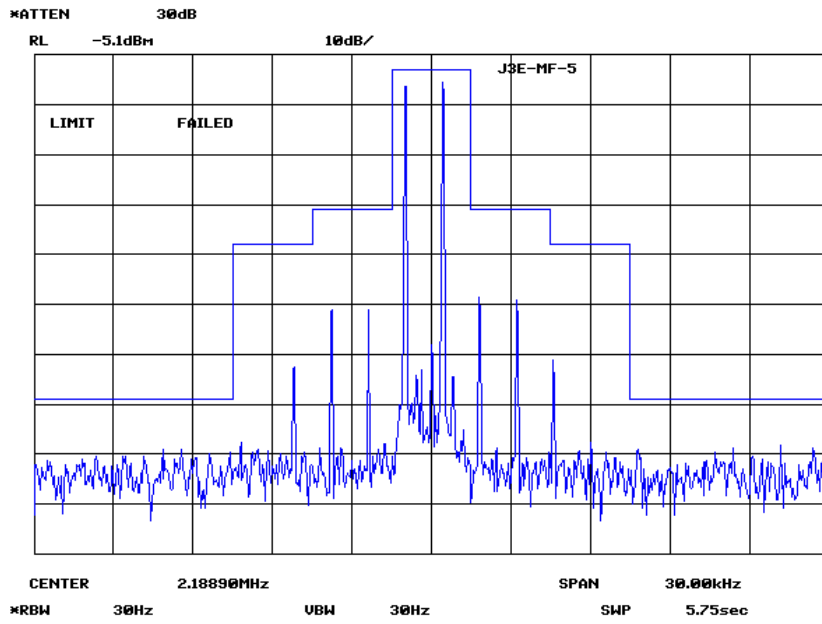

Fig. 2.3.2-7 Occupied bandwidth
Frequency:2187.5kHz
Mode:J3E
Line Voltage:AC220V

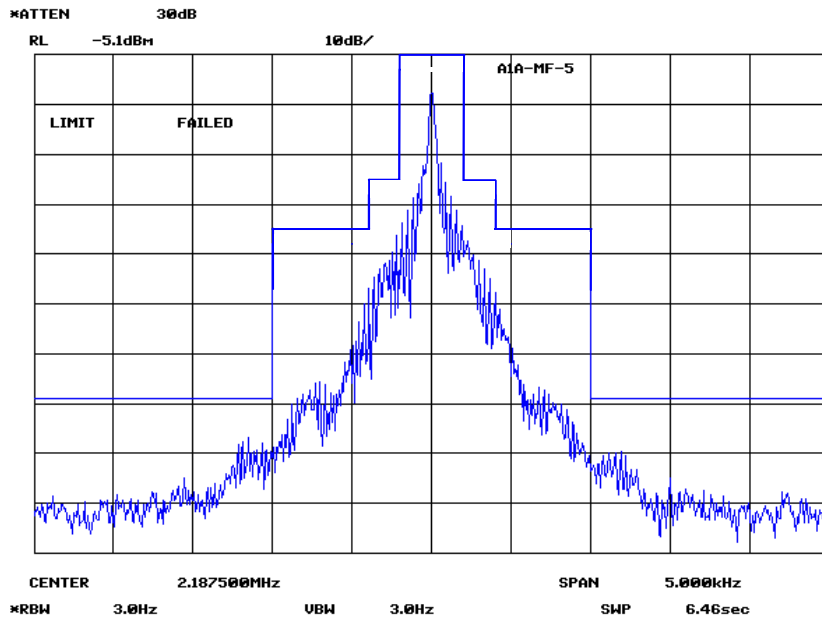

Fig. 2.3.2-8 Occupied bandwidth
Frequency:2187.5kHz
Mode:A1A
Line Voltage:AC220V

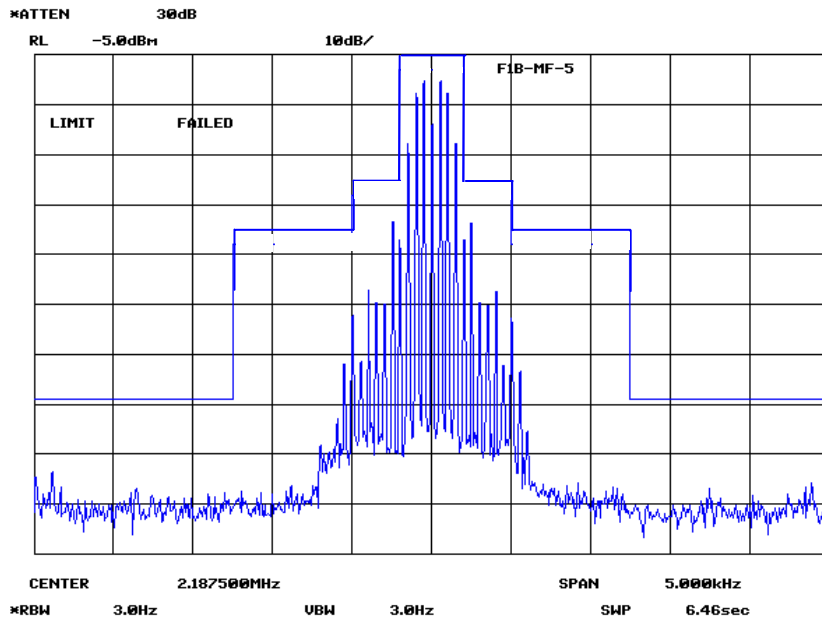

Fig. 2.3.2-9 Occupied bandwidth
Frequency:2187.5kHz
Mode:F1B
Line Voltage:AC220V

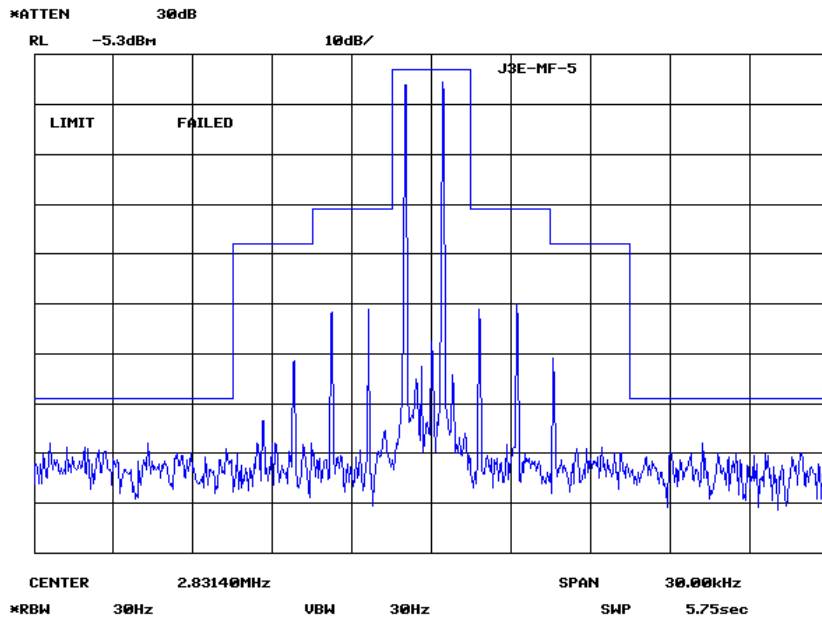

Fig. 2.3.2-10 Occupied bandwidth
Frequency:2830.0kHz
Mode:J3E
Line Voltage:AC220V

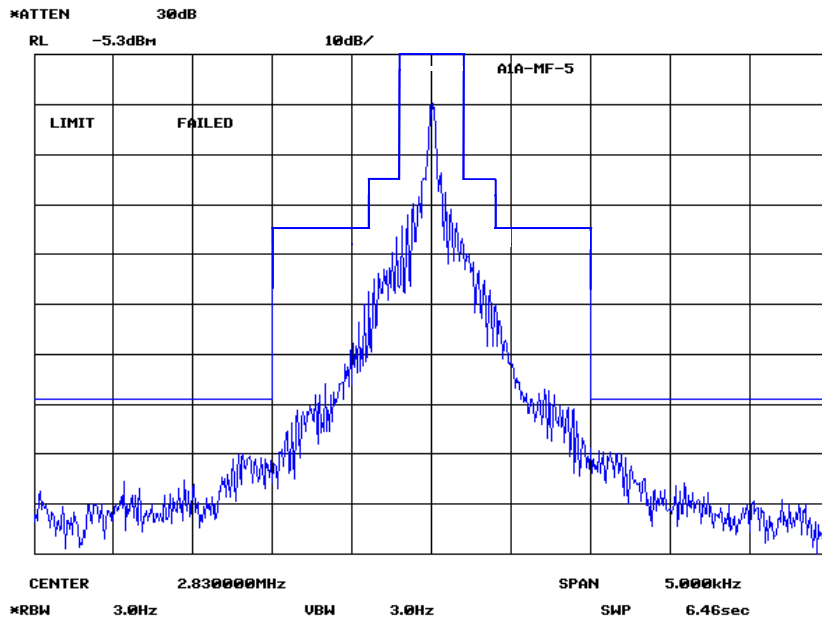

Fig. 2.3.2-11 Occupied bandwidth
Frequency:2830.0kHz
Mode:A1A
Line Voltage:AC220V

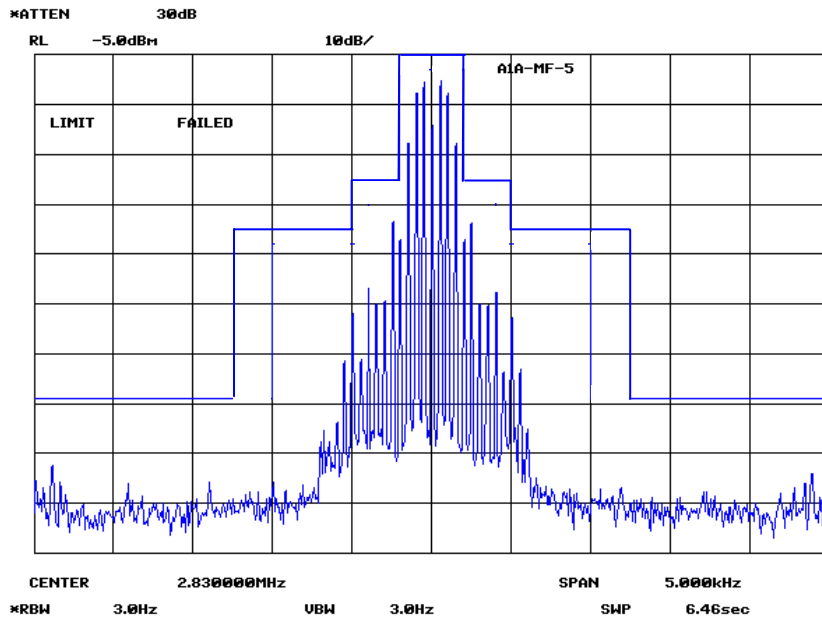

Fig. 2.3.2-12 Occupied bandwidth
Frequency:2830.0kHz
Mode:F1B
Line Voltage:AC220V

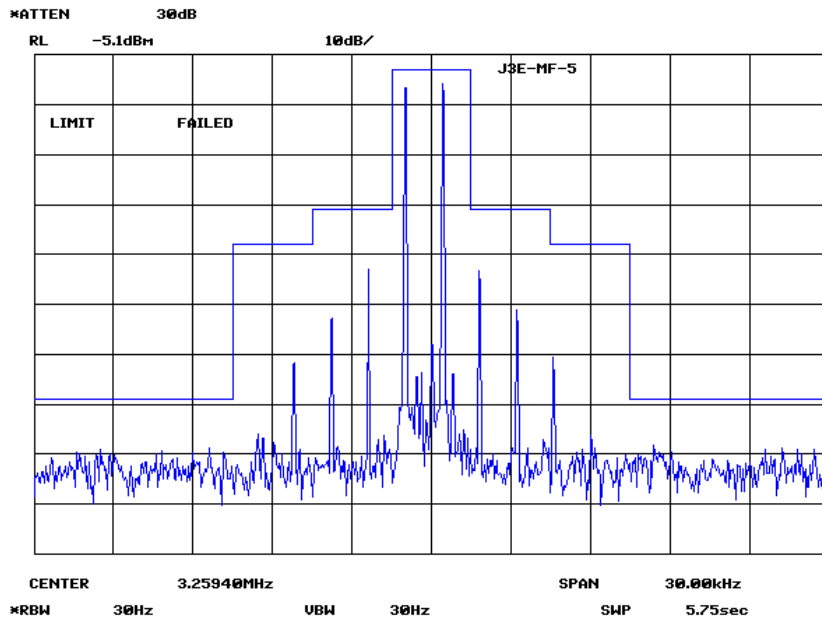

Fig. 2.3.2-13 Occupied bandwidth
Frequency:3258.0kHz
Mode:J3E
Line Voltage:AC220V

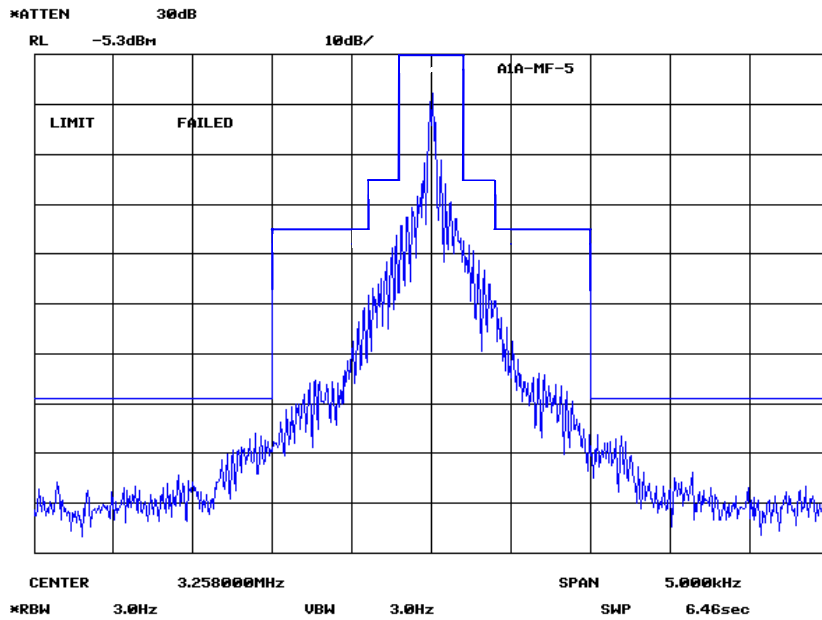

Fig. 2.3.2-14 Occupied bandwidth
Frequency:3258.0kHz
Mode:A1A
Line Voltage:AC220V

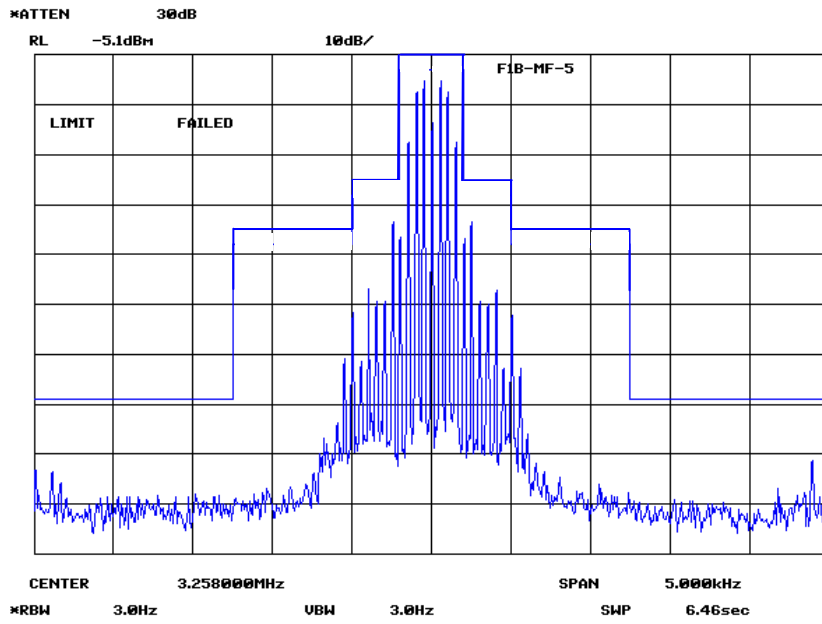

Fig. 2.3.2-15 Occupied bandwidth
Frequency:3258.0kHz
Mode:F1B
Line Voltage:AC220V

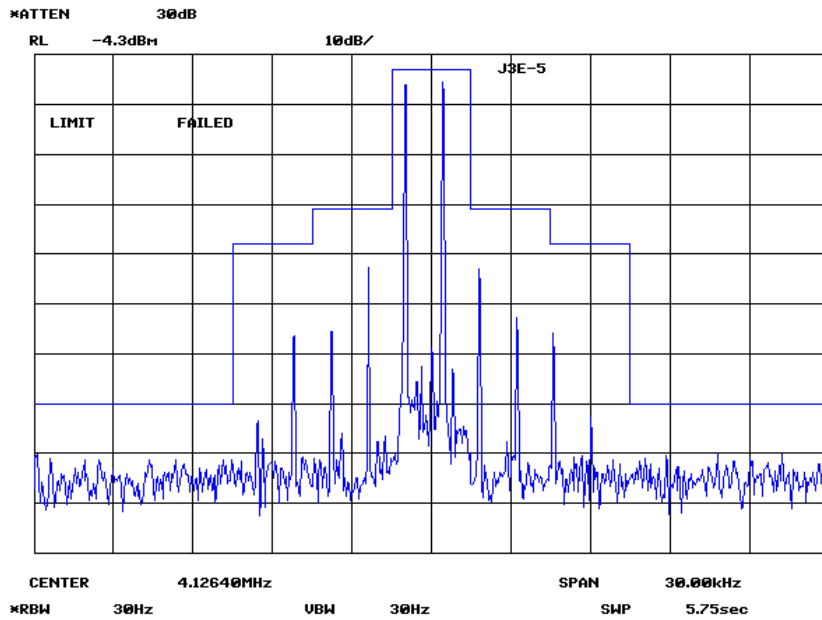

Fig. 2.3.2-16 Occupied bandwidth
Frequency:4125.0kHz
Mode:J3E
Line Voltage:AC220V

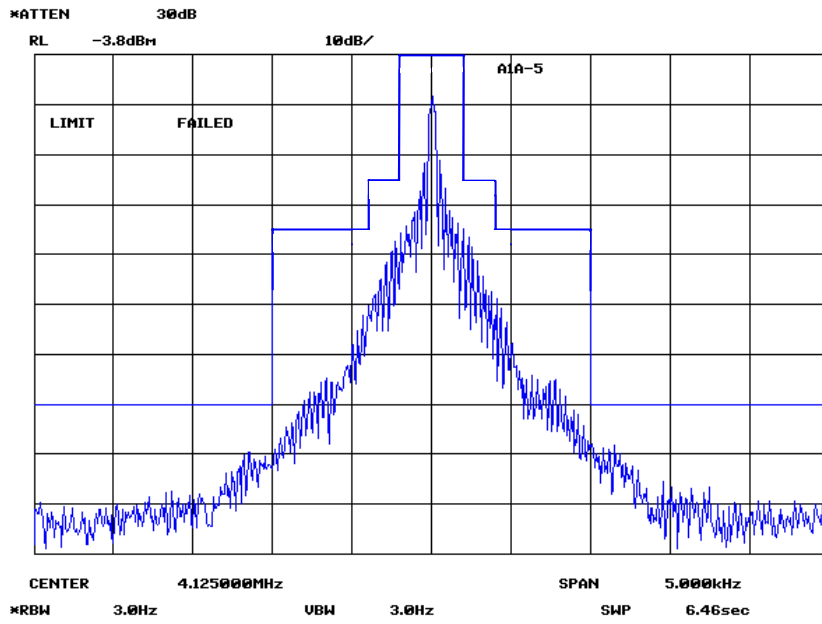

Fig. 2.3.2-17 Occupied bandwidth
Frequency:4125.0kHz
Mode:A1A
Line Voltage:AC220V

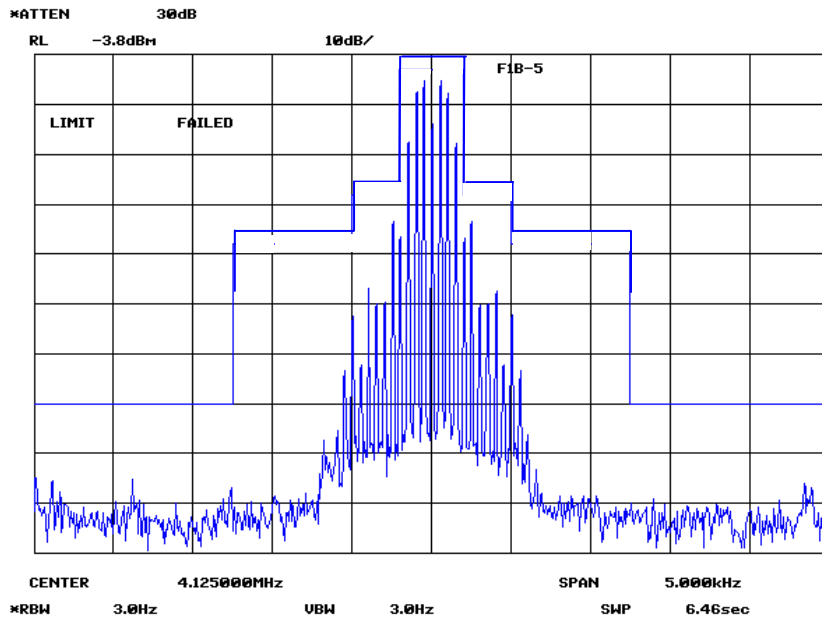

Fig. 2.3.2-18 Occupied bandwidth
Frequency:4125.0kHz
Mode:F1B
Line Voltage:AC220V

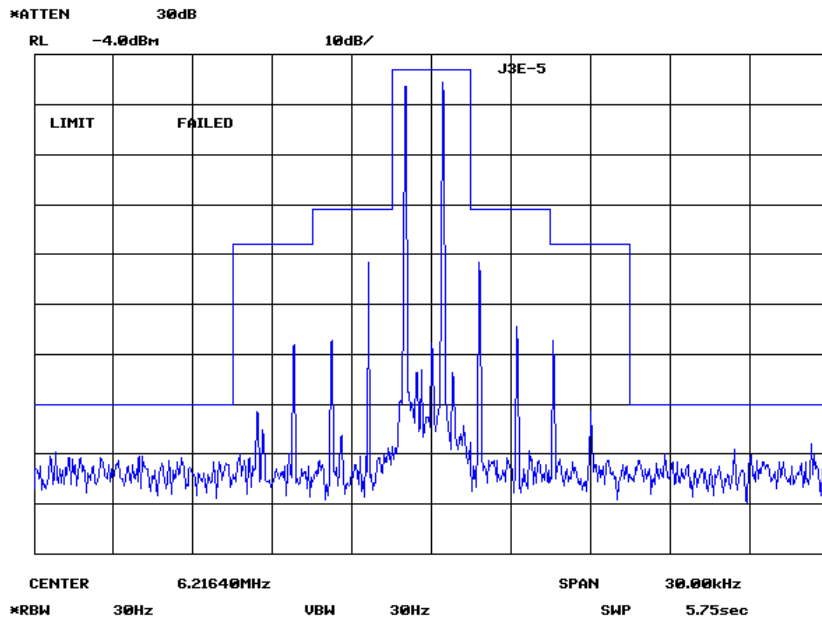

Fig. 2.3.2-19 Occupied bandwidth
Frequency:6215.0kHz
Mode:J3E
Line Voltage:AC220V

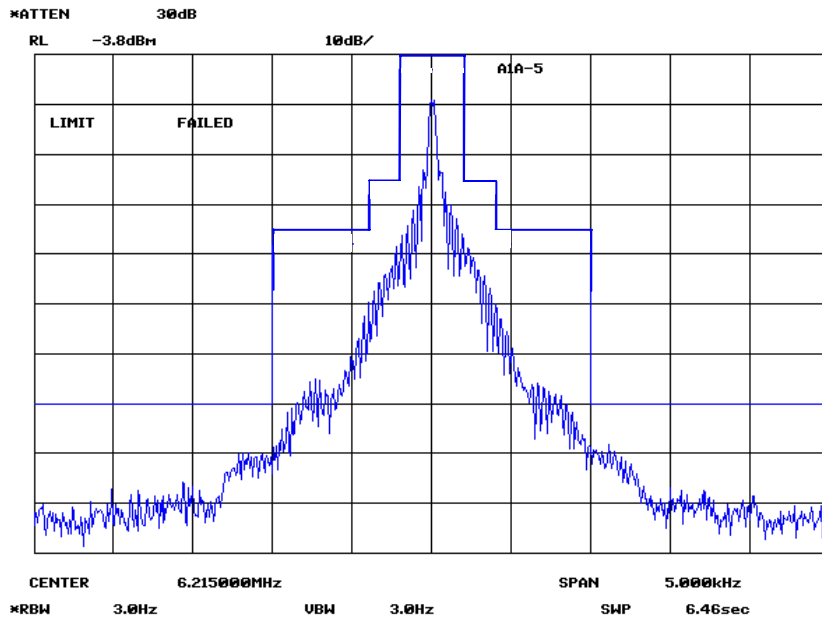

Fig. 2.3.2-20 Occupied bandwidth
Frequency:6215.0kHz
Mode:A1A
Line Voltage:AC220V

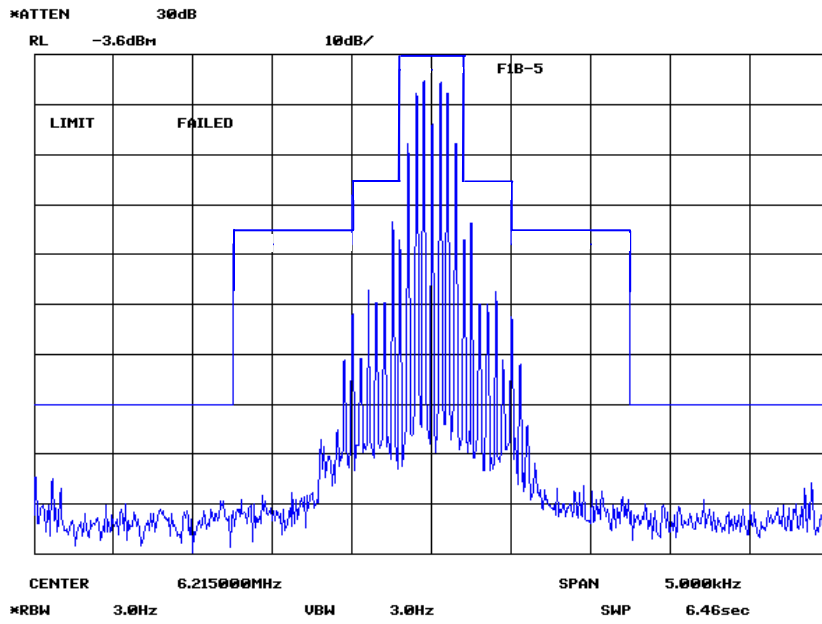

Fig. 2.3.2-21 Occupied bandwidth
 Frequency:6215.0kHz
 Mode:F1B
 Line Voltage:AC220V

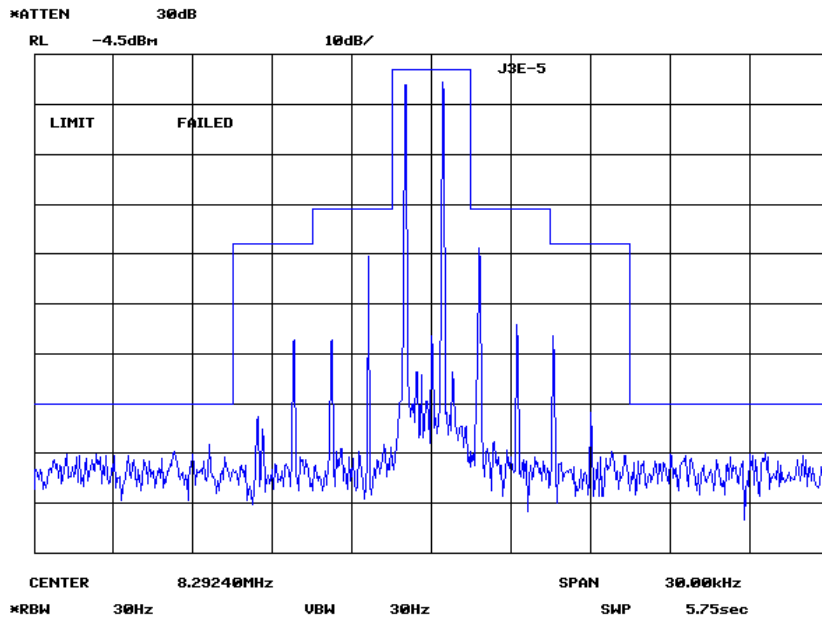

Fig. 2.3.2-22 Occupied bandwidth
 Frequency:8291.0kHz
 Mode:J3E
 Line Voltage:AC220V

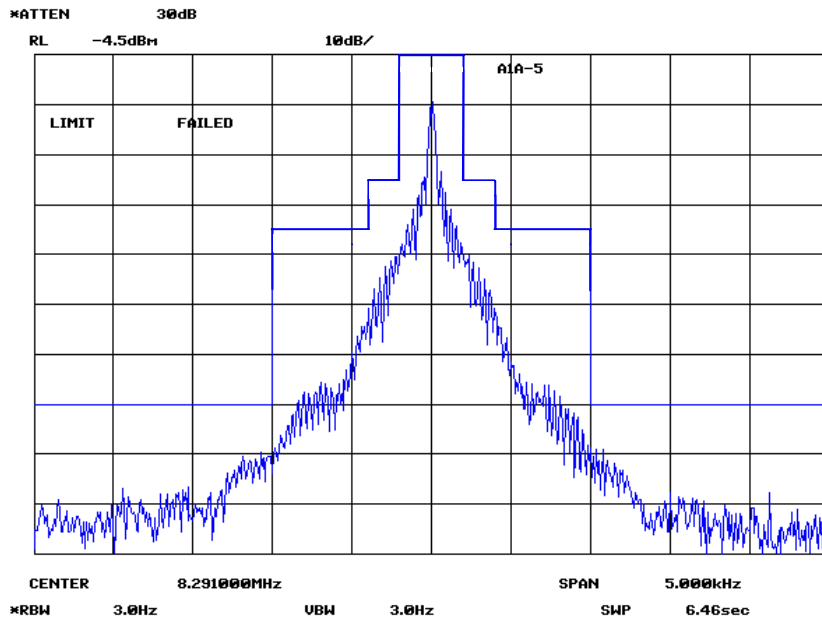

Fig. 2.3.2-23 Occupied bandwidth
Frequency:8291.0kHz
Mode:A1A
Line Voltage:AC220V

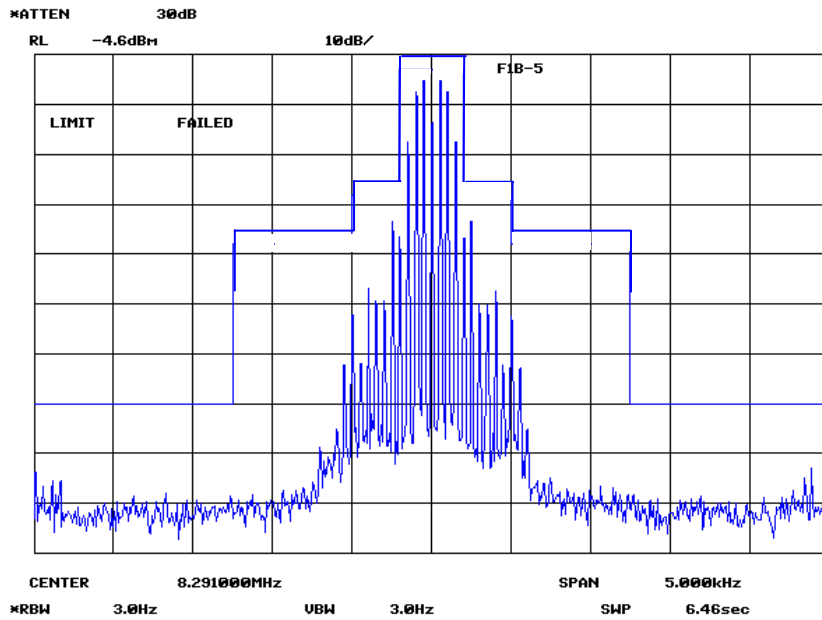

Fig. 2.3.2-24 Occupied bandwidth
Frequency:8291.0kHz
Mode:F1B
Line Voltage:AC220V

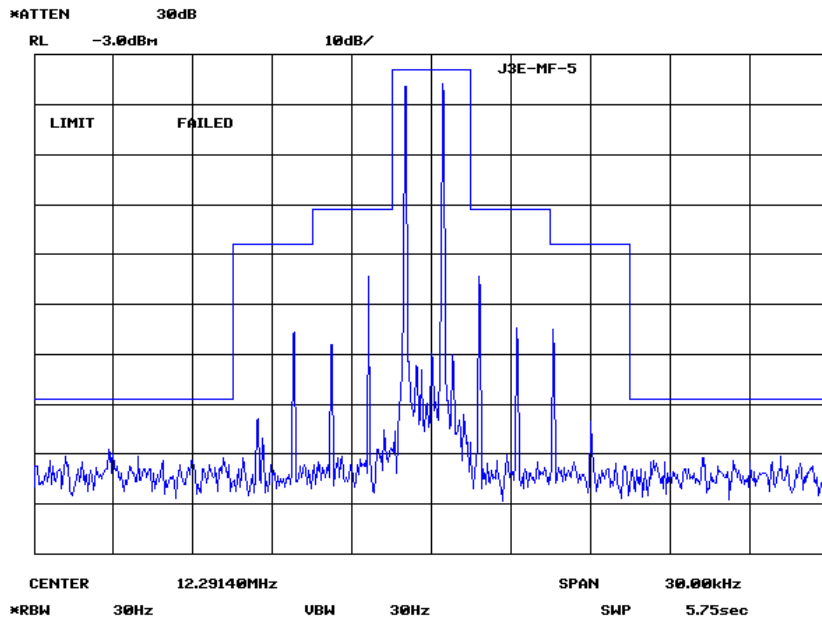

Fig. 2.3.2-25 Occupied bandwidth
Frequency:12290.0kHz
Mode:J3E
Line Voltage:AC220V

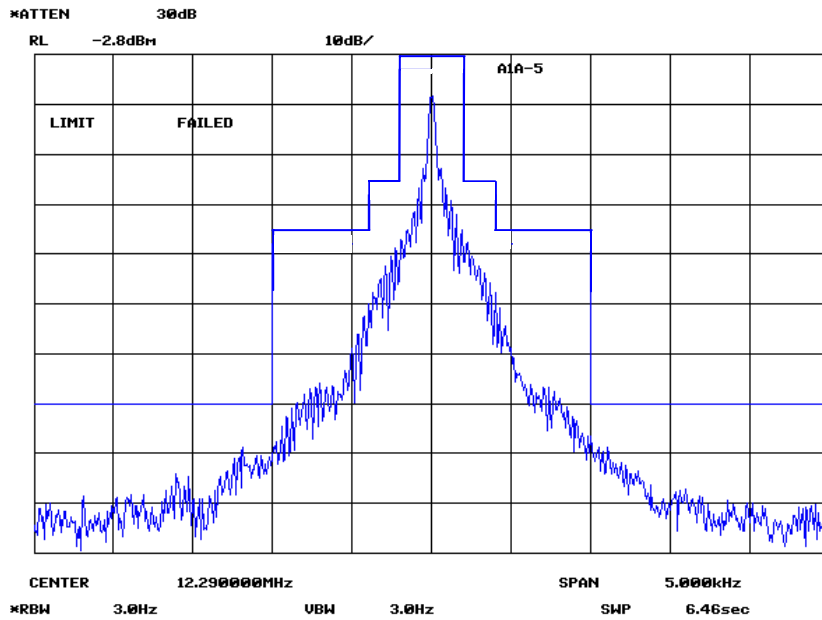

Fig. 2.3.2-26 Occupied bandwidth
Frequency:12290.0kHz
Mode:A1A
Line Voltage:AC220V

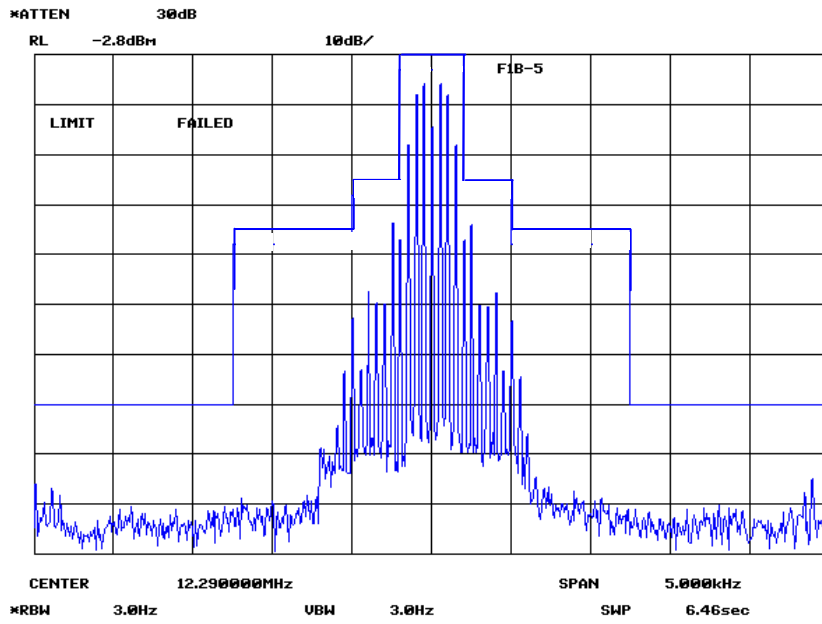

Fig. 2.3.2-27 Occupied bandwidth
 Frequency:12290.0kHz
 Mode:F1B
 Line Voltage:AC220V

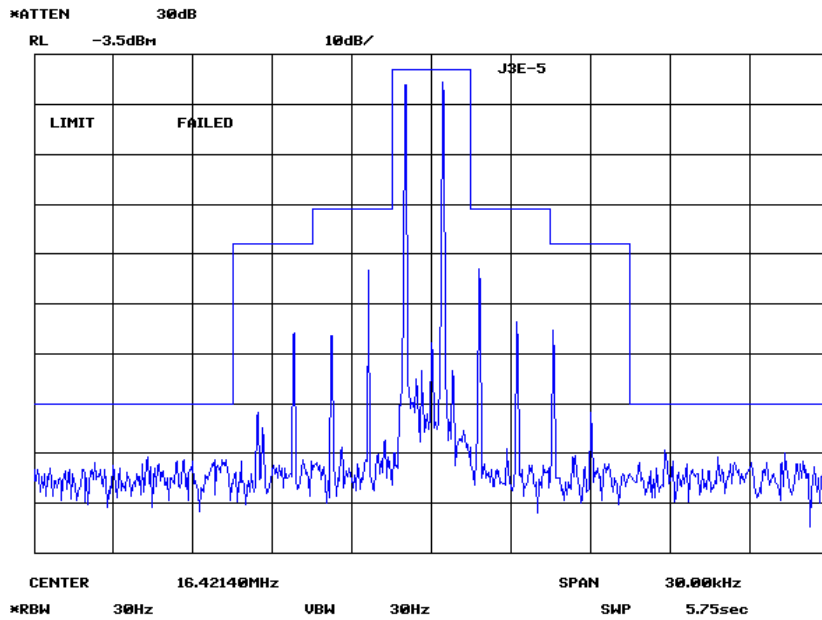

Fig. 2.3.2-28 Occupied bandwidth
 Frequency:16420.0kHz
 Mode:J3E
 Line Voltage:AC220V

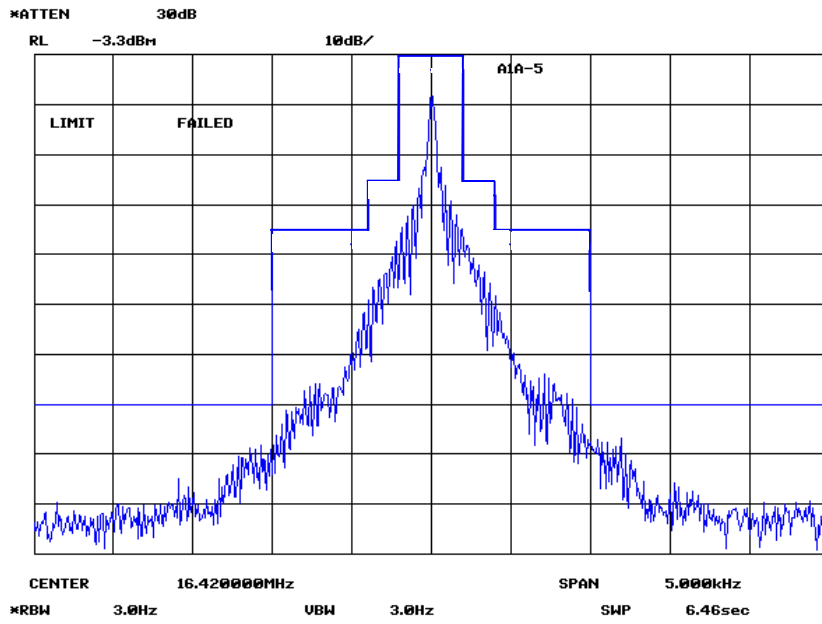

Fig. 2.3.2-29 Occupied bandwidth
Frequency:16420.0kHz
Mode:A1A
Line Voltage:AC220V

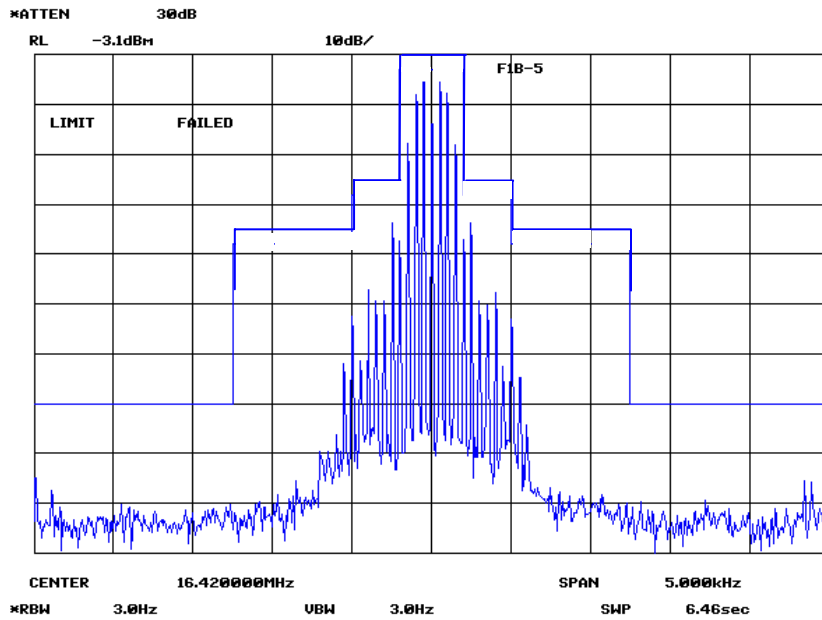

Fig. 2.3.2-30 Occupied bandwidth
Frequency:16420.0kHz
Mode:F1B
Line Voltage:AC220V

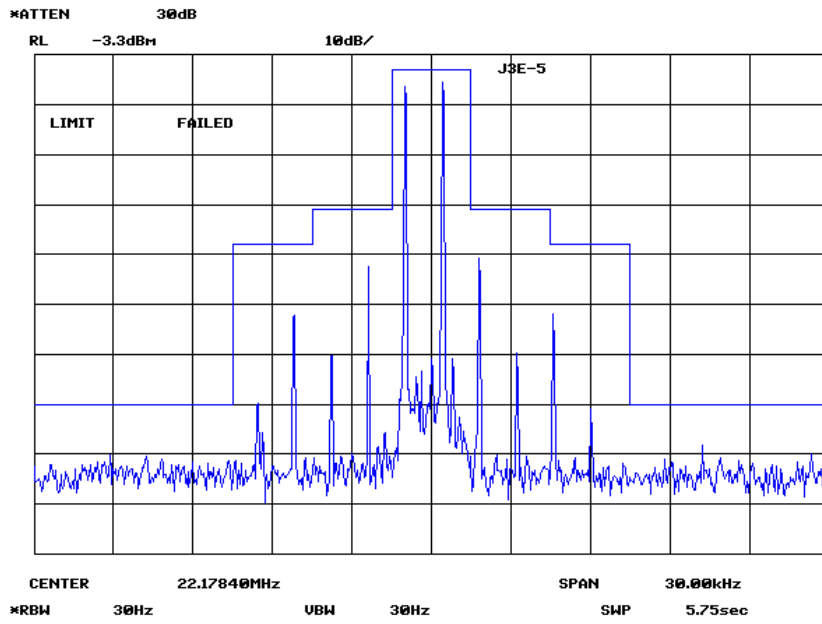

Fig. 2.3.2-31 Occupied bandwidth
Frequency:22177.0kHz
Mode:J3E
Line Voltage:AC220V

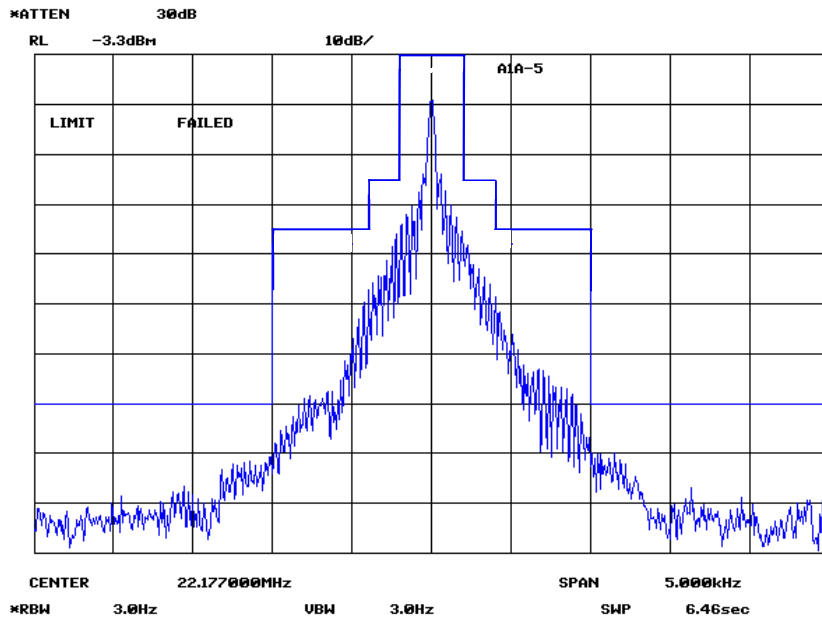

Fig. 2.3.2-32 Occupied bandwidth
Frequency:22177.0kHz
Mode:A1A
Line Voltage:AC220V

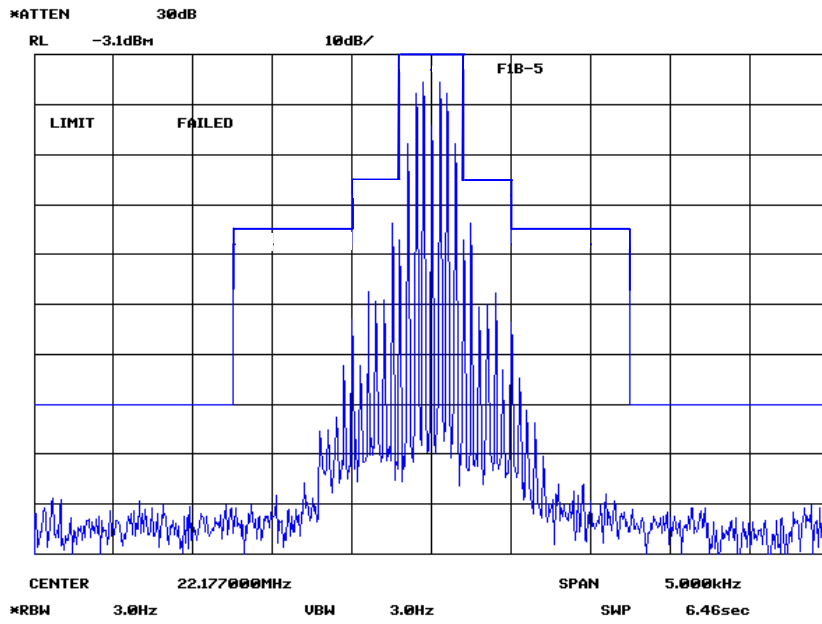

Fig. 2.3.2-33 Occupied bandwidth
 Frequency:22177.0kHz
 Mode:F1B
 Line Voltage:AC220V

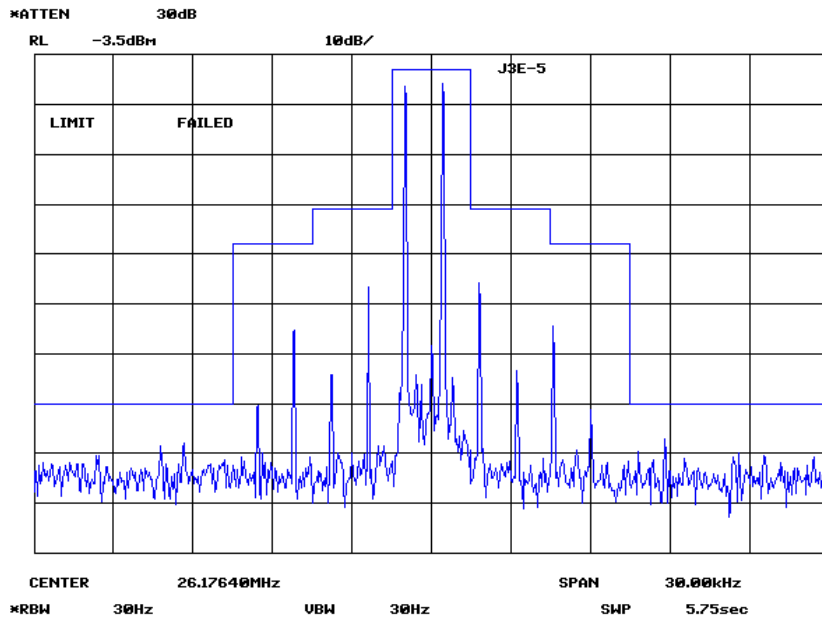

Fig. 2.3.2-34 Occupied bandwidth
 Frequency:26175.0kHz
 Mode:J3E
 Line Voltage:AC220V

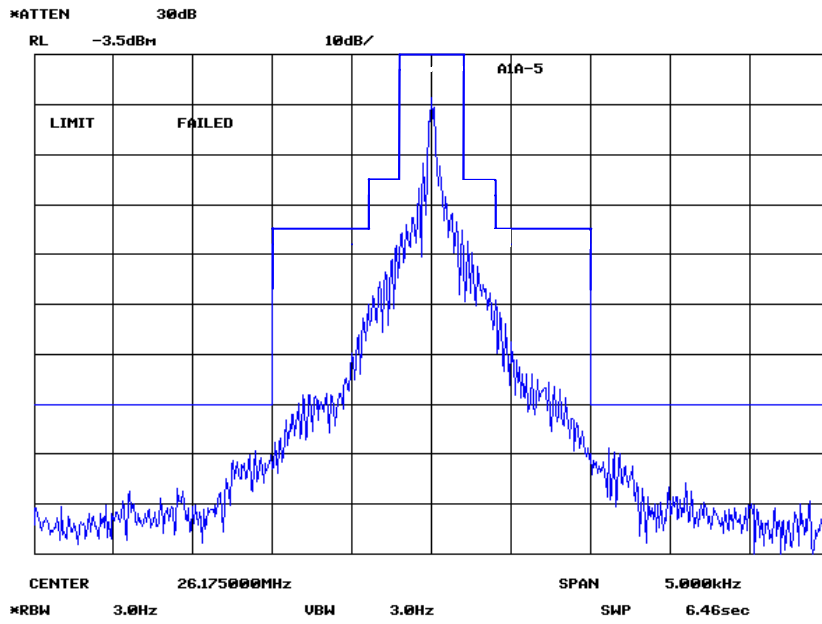

Fig. 2.3.2-35 Occupied bandwidth
Frequency:26175.0kHz
Mode:A1A
Line Voltage:AC220V

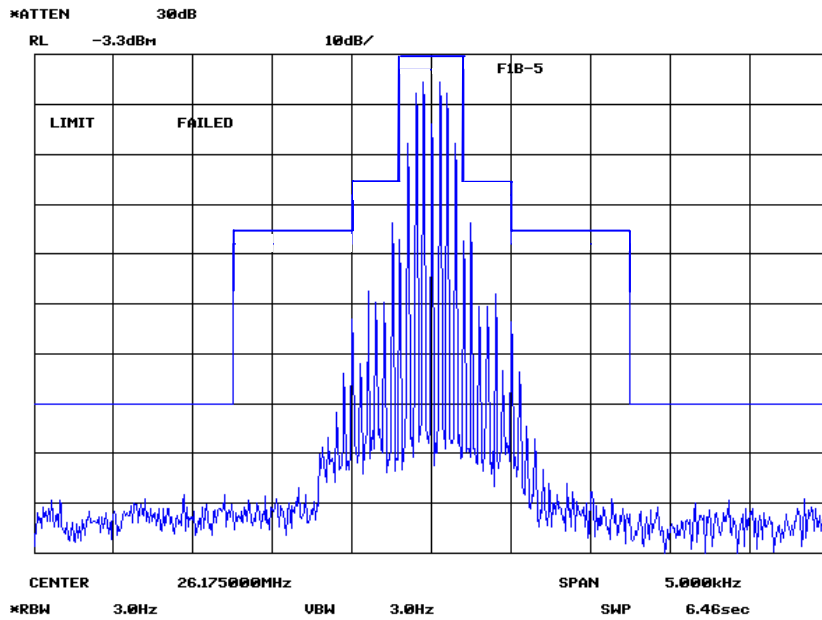

Fig. 2.3.2-36 Occupied bandwidth
Frequency:26175.0kHz
Mode:F1B
Line Voltage:AC220V

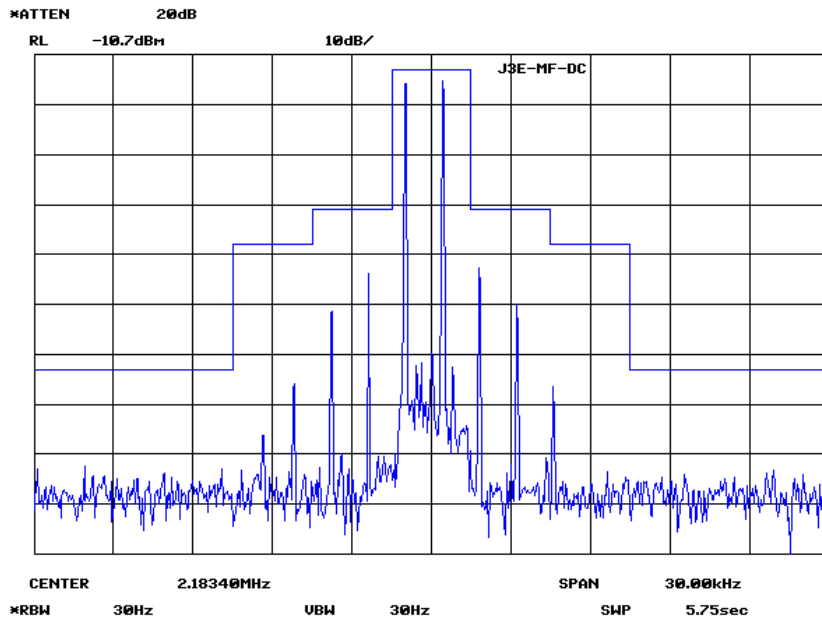

Fig. 2.3.2-37 Occupied bandwidth
Frequency:2182.0kHz
Mode:J3E
Line Voltage: DC24V

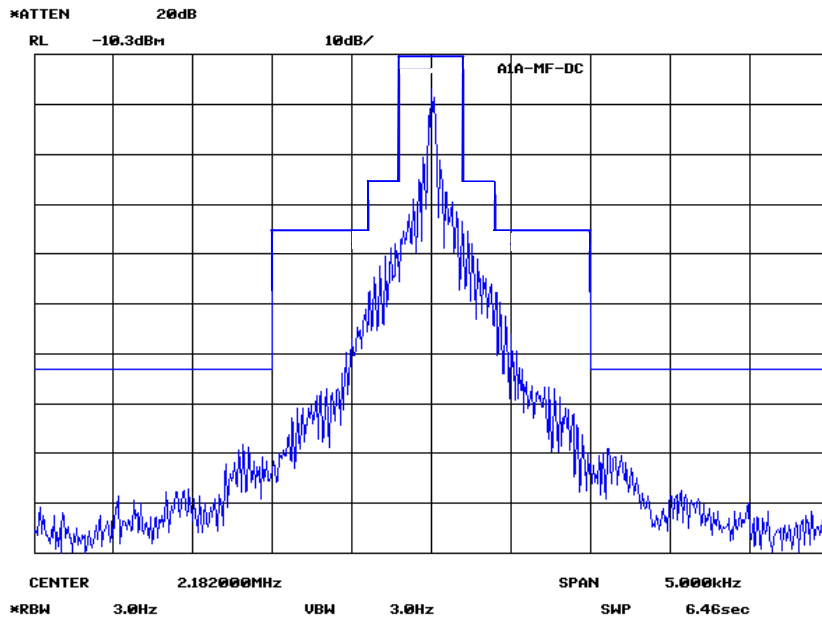

Fig. 2.3.2-38 Occupied bandwidth
Frequency:2182.0kHz
Mode:A1A
Line Voltage: DC24V

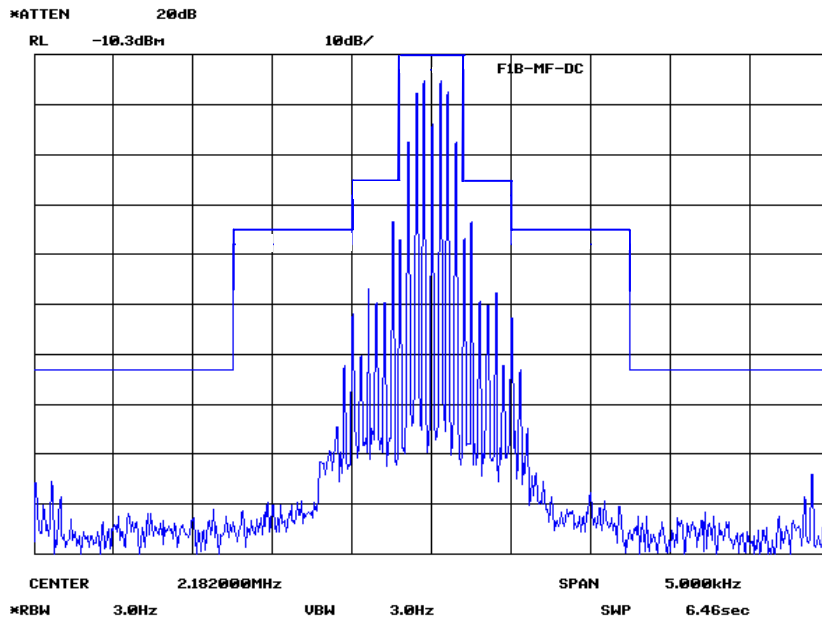

Fig. 2.3.2-39 Occupied bandwidth
Frequency:2182.0kHz
Mode:F1B
Line Voltage: DC24V

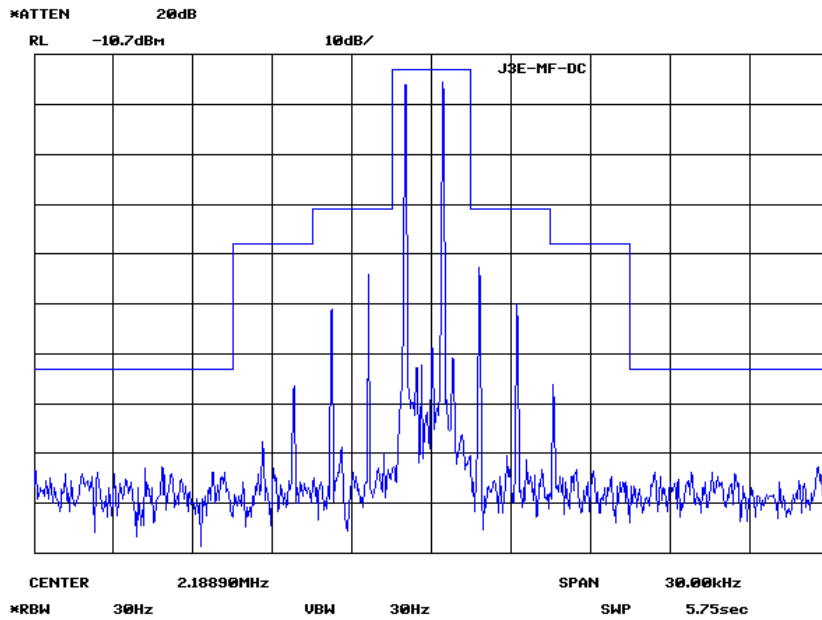

Fig. 2.3.2-40 Occupied bandwidth
Frequency:2187.5kHz
Mode:J3E
Line Voltage: DC24V

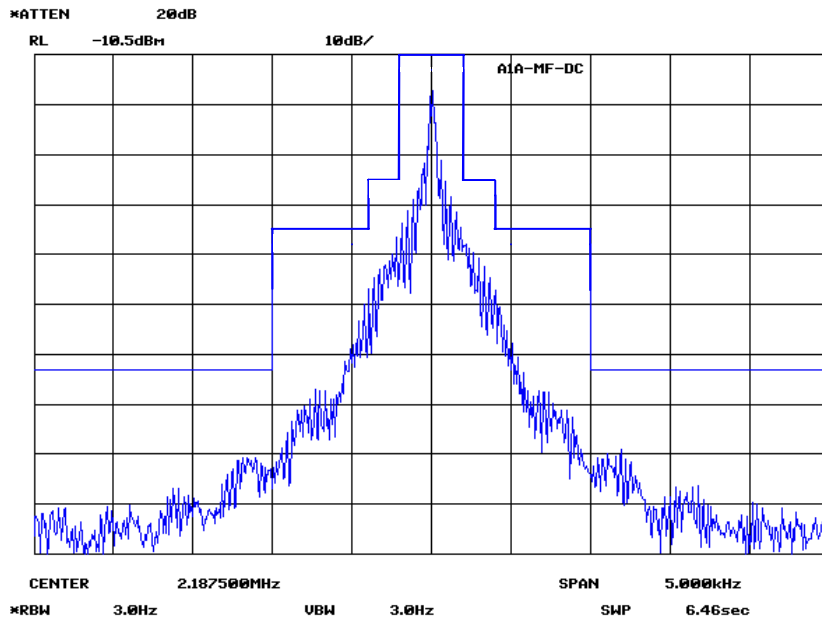

Fig. 2.3.2-41 Occupied bandwidth
Frequency:2187.5kHz
Mode:A1A
Line Voltage: DC24V

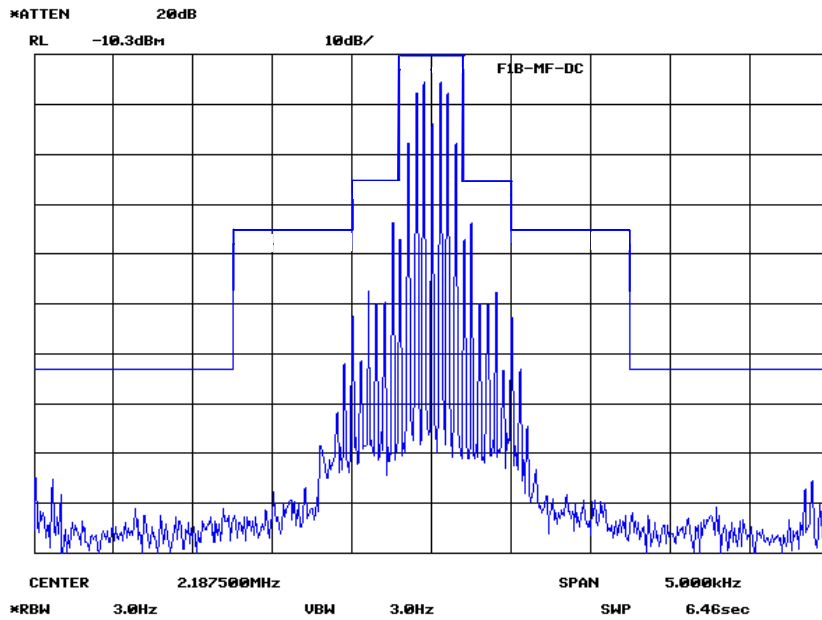

Fig. 2.3.2-42 Occupied bandwidth
Frequency:2187.5kHz
Mode:F1B
Line Voltage: DC24V

2.4 Spurious emissions at antenna terminal [FCC §2.1051, §80.211(a),(f)]

2.4.1 Test procedure

The Radio Equipment JSS-2500N was connected as shown in Fig. 2.4.1.

The equipment under test was operated in J3E mode and in all cases. The J3E modulation level was shown in Fig. 2.2.2.2 of the Modulation limiting characteristics. The J3E audio input level was constant at 10dB over the rated output power as per §2.1047(c). The output spectrum was investigated for the worst case in the frequency range of the transmitter, and the output form was commensurable with that shown in section 2.1 and 2.2 of this test data.

The equipment was tested in J3E mode included in the transmitter frequency range.

2.4.2 Test results

The results are shown from Fig. 2.4.2-1 to Fig. 2.4.2-14.

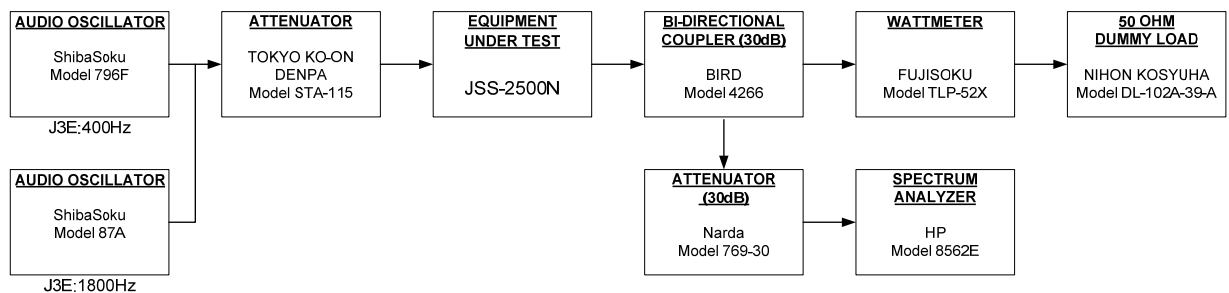

Fig. 2.4.1 Test set up for Spurious emissions at antenna terminal

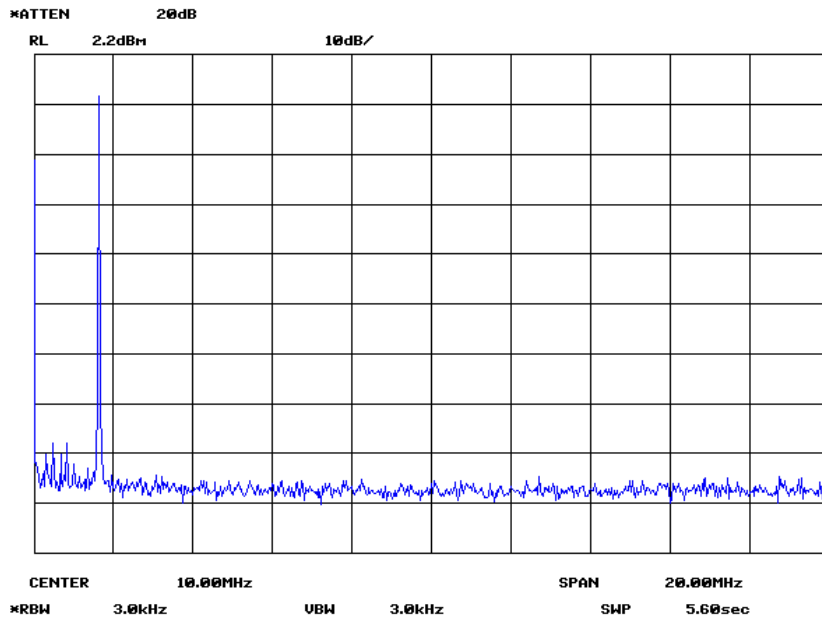

Fig. 2.4.2-1 Spurious emissions at antenna terminal
Frequency:1619.0kHz
Mode:J3E
Line Voltage:AC220V

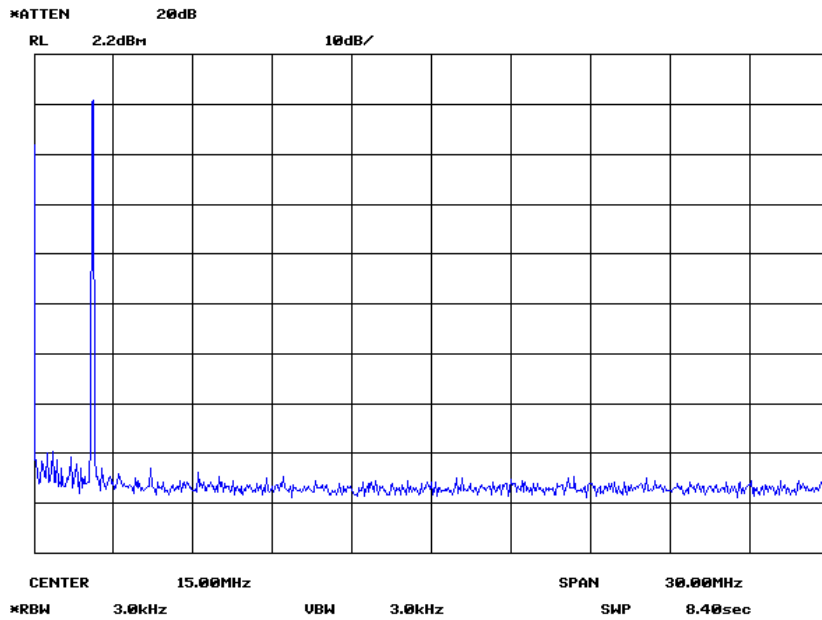

Fig. 2.4.2-2 Spurious emissions at antenna terminal
Frequency:2182.0kHz
Mode:J3E
Line Voltage:AC220V

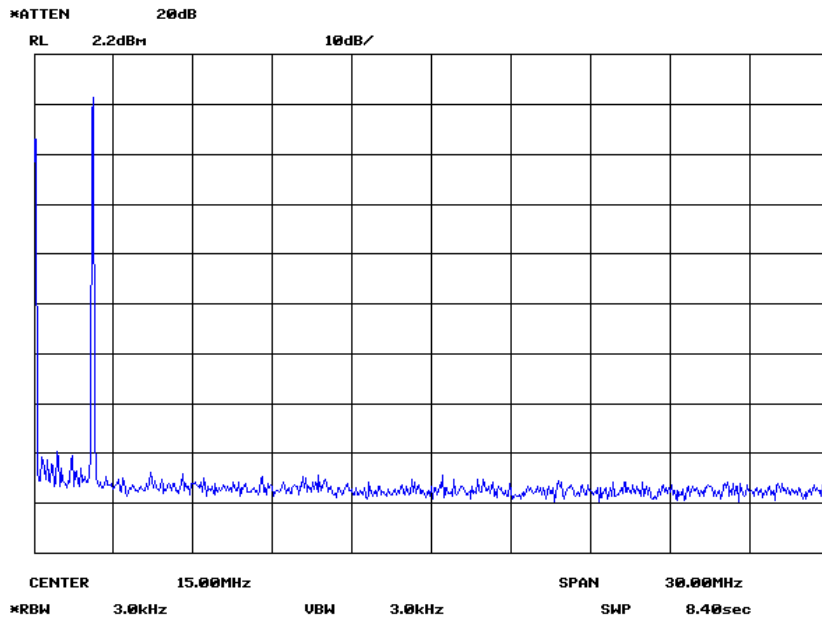

Fig. 2.4.2-3 Spurious emissions at antenna terminal
Frequency:2187.5kHz
Mode:J3E
Line Voltage:AC220V

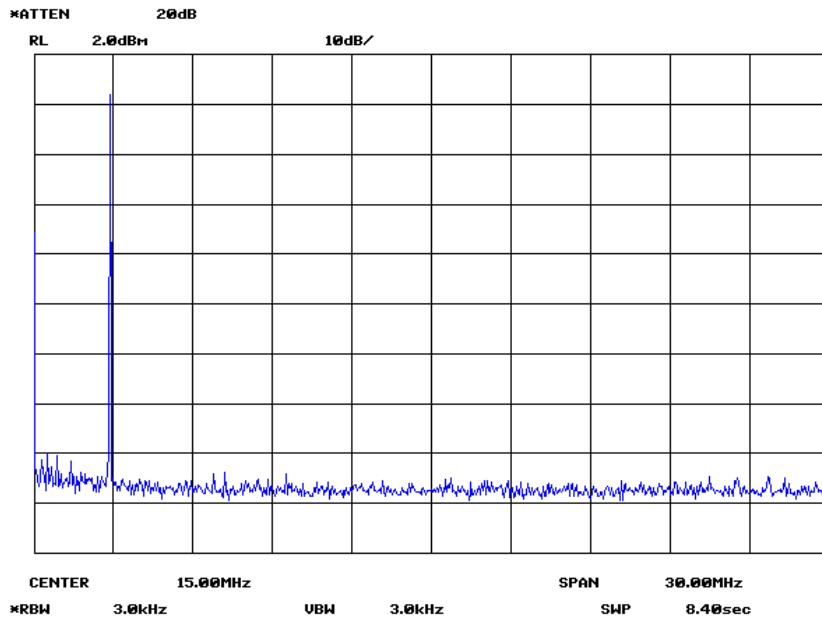

Fig. 2.4.2-4 Spurious emissions at antenna terminal
Frequency:2830.0kHz
Mode:J3E
Line Voltage:AC220V

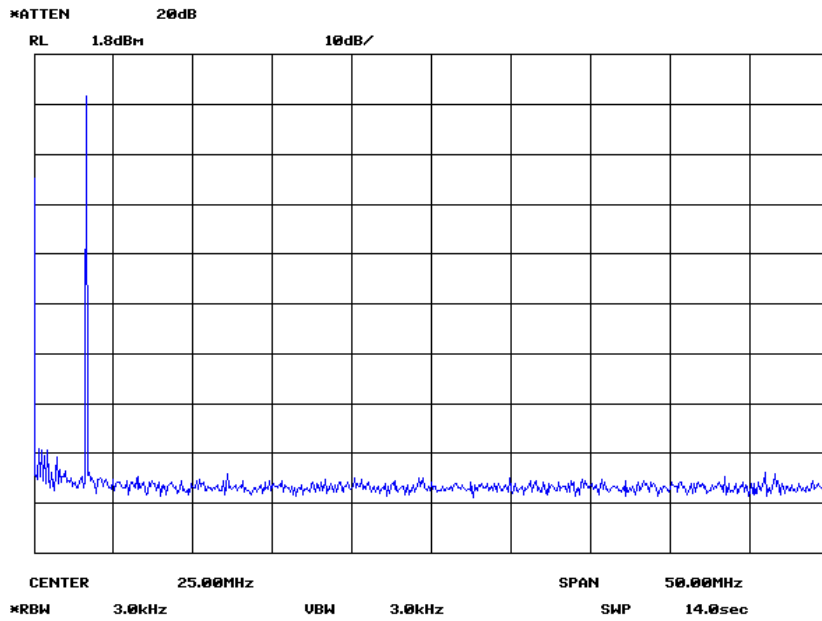

Fig. 2.4.2-5 Spurious emissions at antenna terminal
Frequency:3258.0kHz
Mode:J3E
Line Voltage:AC220V

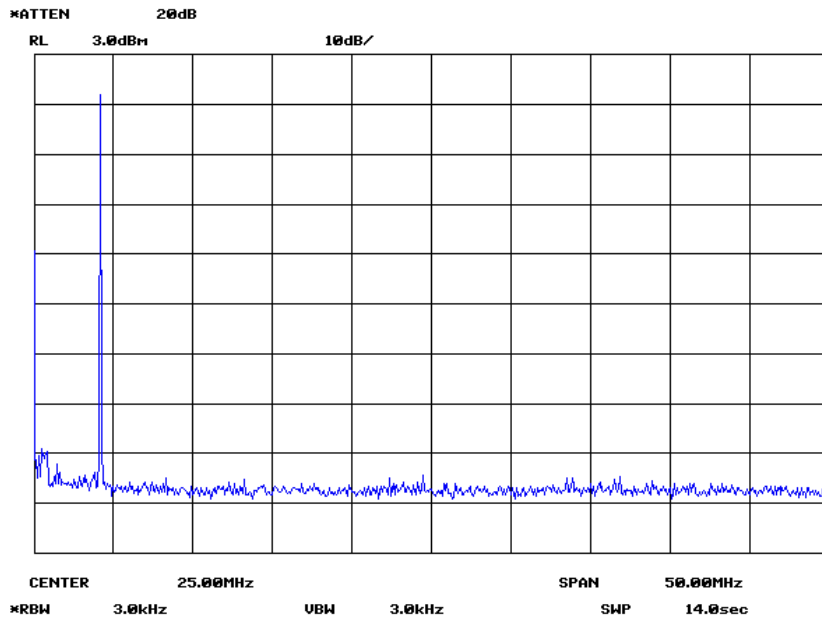

Fig. 2.4.2-6 Spurious emissions at antenna terminal
Frequency:4125.0kHz
Mode:J3E
Line Voltage:AC220V

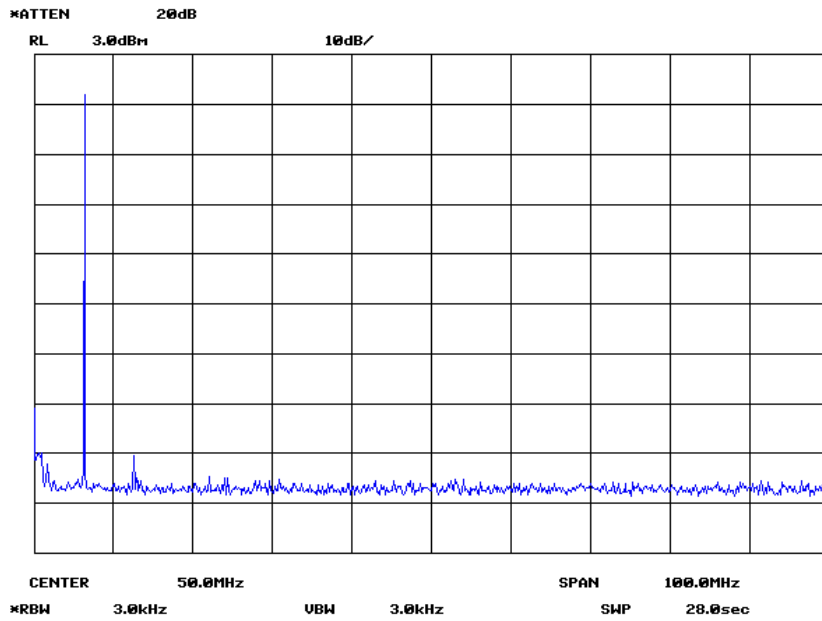

Fig. 2.4.2-7 Spurious emissions at antenna terminal
Frequency:6215.0kHz
Mode:J3E
Line Voltage:AC220V

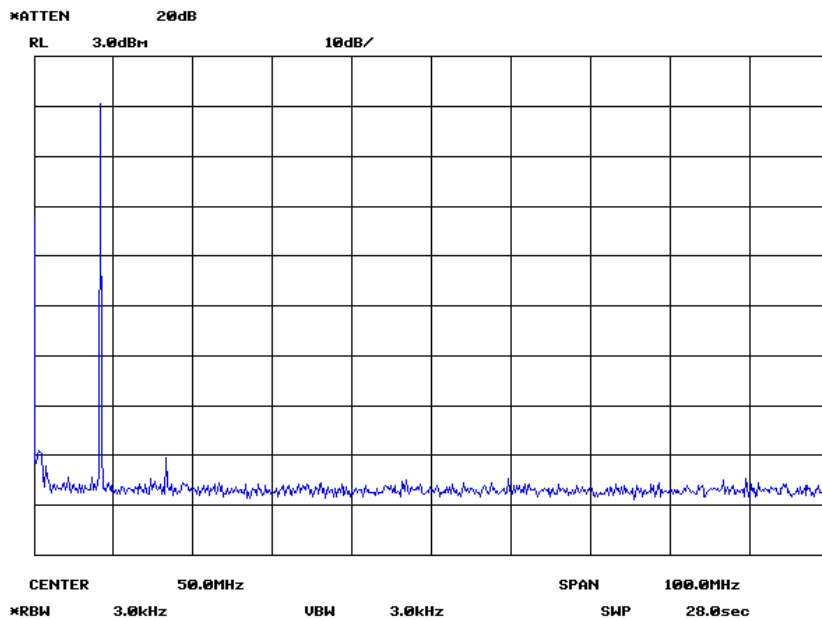

Fig. 2.4.2-8 Spurious emissions at antenna terminal
Frequency:8291.0kHz
Mode:J3E
Line Voltage:AC220V

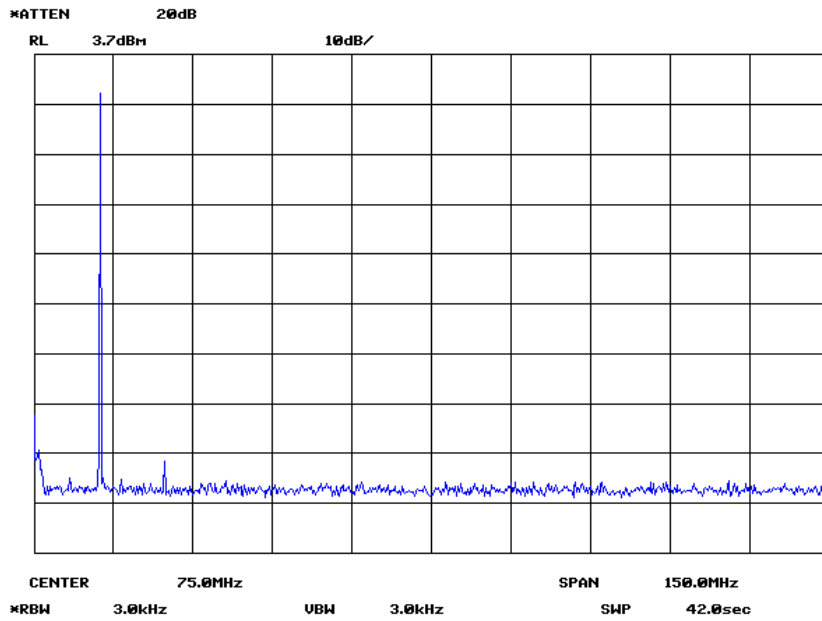

Fig. 2.4.2-9 Spurious emissions at antenna terminal
Frequency:12290.0kHz
Mode:J3E
Line Voltage:AC220V

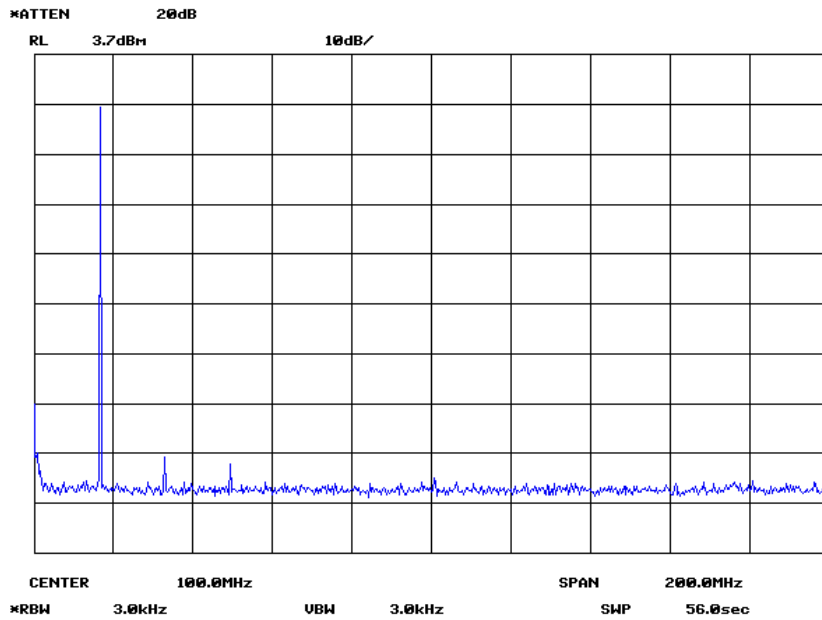

Fig. 2.4.2-10 Spurious emissions at antenna terminal
Frequency:16420.0kHz
Mode:J3E
Line Voltage:AC220V

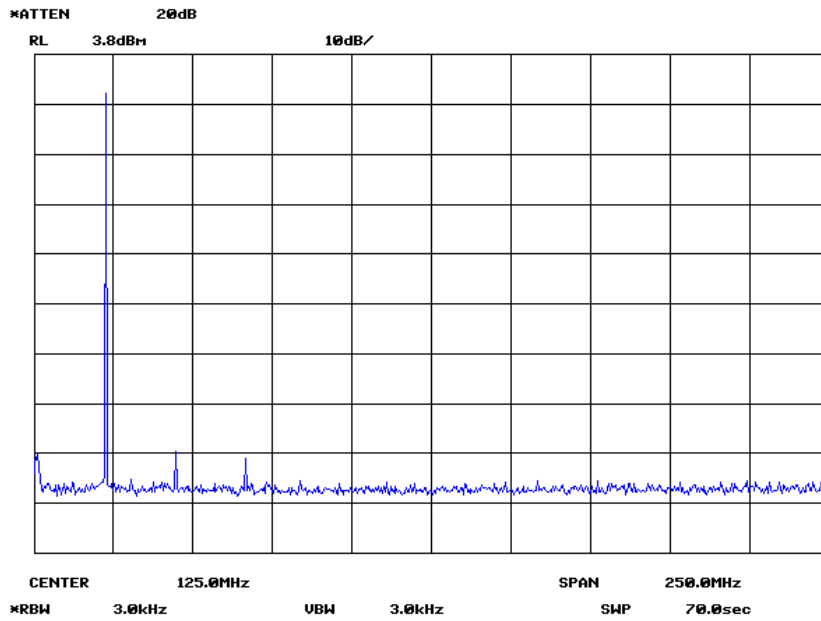

Fig. 2.4.2-11 Spurious emissions at antenna terminal
Frequency:22177.0kHz
Mode:J3E
Line Voltage:AC220V

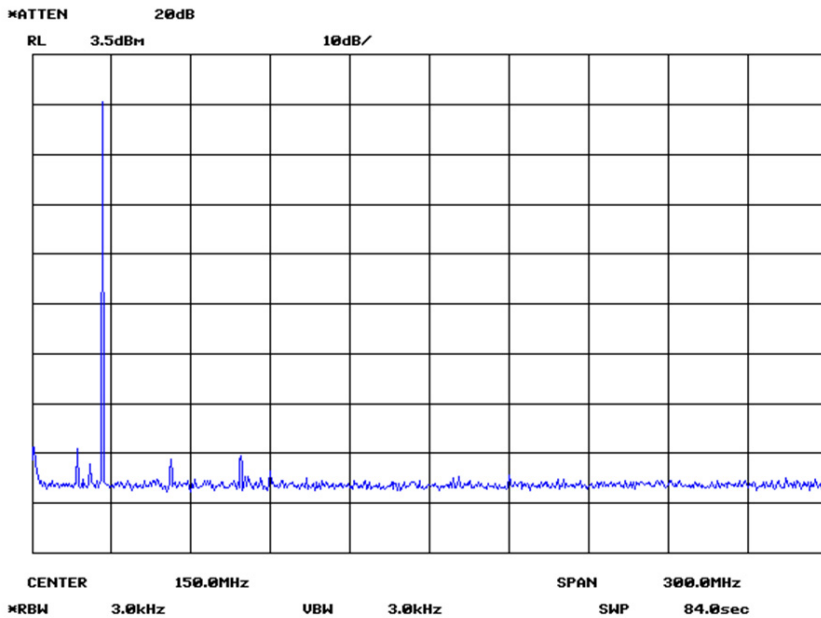

Fig. 2.4.2-12 Spurious emissions at antenna terminal
Frequency:26175.0kHz
Mode:J3E
Line Voltage:AC220V

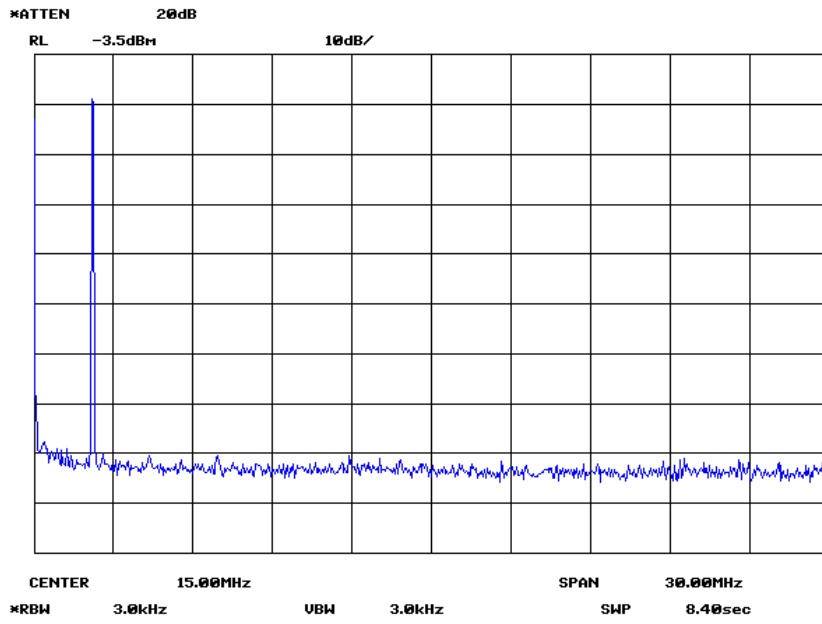

Fig. 2.4.2-13 Spurious emissions at antenna terminal
Frequency:2182.0kHz
Mode:J3E
Line Voltage:DC24V

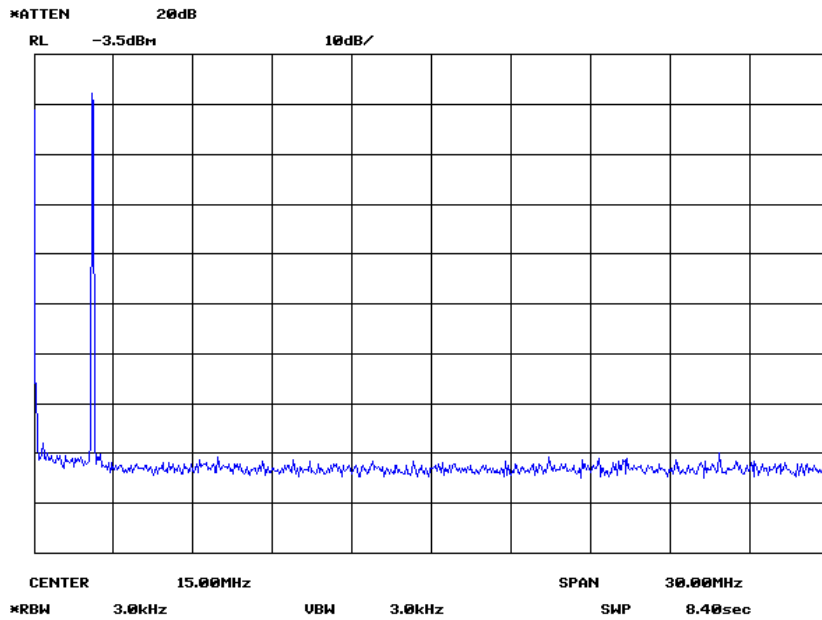

Fig. 2.4.2-14 Spurious emissions at antenna terminal
Frequency:2187.5kHz
Mode:J3E
Line Voltage:DC24V

2.5 Field strength of spurious radiation [FCC §2.1053]

2.5.1 Test procedure

The transmitter was tested for radiated spurious emissions in J3E mode.

During this procedure, the transmitter was tuned to 8.291MHz and the input levels of two tones, 400Hz and 1800Hz, were so adjusted that the two principal frequency components of the radio frequency signal produced were equal in magnitude.

Initially, the radiating frequencies were identified and recorded within a shielded enclosure. The test set up was then re-located to an open field test site.

A nonconductive platform was used to support the transmitter and the dummy load. The power supply leads extended vertically downwards to a power supply located at the bottom of the nonconductive platform. The receiving antenna was located 3 meters from the transmitter during testing.

Two types of antenna were used whichever antenna corresponded to the portion of the spectrum being investigated. The actual magnitude of any unwanted signals was determined with a spectrum analyzer. The level of each spurious signal between 20MHz and 1000MHz was noted.

Field strength was then calculated after adding the necessary cable losses and antenna correction factors. The reference field strength was calculated using the following equation.

$$E = ((49.2) \times (Pt))^{1/2} / D^*$$

Where : E = Field strength (V/Meter)
Pt = Transmitter power (Watts)
D = Distance from transmitter (Meters)

* "Reference Data for Radio Engineers". Fifth Edition, Page 25-7.

2.5.2 Test results

Test results are shown in Table 2.5.1.

In all of the following tables, "c" refers to the fundamental carrier frequency of 8291.0kHz. The spurious and harmonic radiated emissions are attenuated not less than -60.0dB.

Table 2.5.1 Field strength of spurious radiation

Test frequency: 8291.0kHz

Mode: J3E

Tone: 400/1800Hz

Line voltage: AC220V

Frequency	Field strength (dBc)
2c	less than -80
3c	
4c	
5c	
6c	
7c	
8c	
9c	
10c	

2.6 Frequency stability
[FCC §2.1055(a)(1), §80.209(a)]

2.6.1 Frequency stability with temperature
[FCC §2.1055(a)(1),(b), §80.209(a)]

2.6.1.1 Test procedure

The Radio Equipment JSS-2500N was placed in an environmental chamber with control and the equipment was connected as shown in Fig.2.6.1.1.

The power supply was set for AC220V and the voltage was monitored during the test. The RF output was fed to 50ohm dummy load and a sample was coupled to the frequency counter.

The equipment was set for the A1A mode. Two test were measured, one at 1619kHz and one at the highest frequency that the transmitter operates, 27499.9kHz.

The temperature chamber was lowed to -30°C and the equipment was allowed to stabilize for one(1) hour. The transmitter was keyed and the frequency recorded. The temperature was raised in 10°C steps to $+50^{\circ}\text{C}$. The equipment was allowed to stabilize for 60 minutes. The frequency was recorded at each temperature after warm-up time.

2.6.1.2 Test results

Test results are shown in Table 2.6.1.2 and Fig. 2.6.1.2.

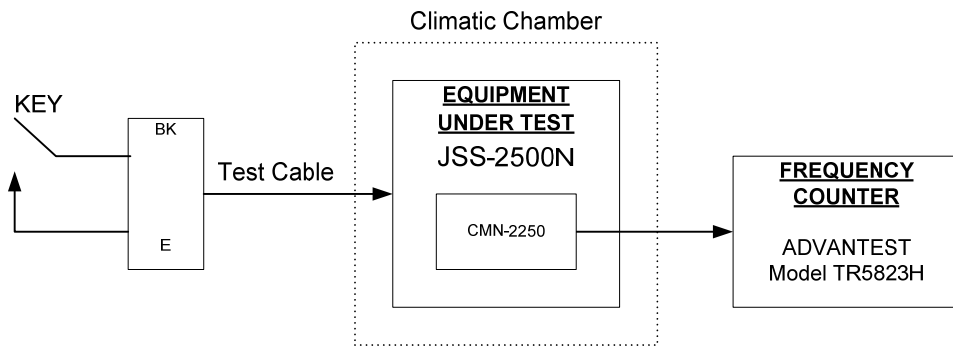

Fig. 2.6.1.1 Test set up for Frequency stability with temperature

Table 2.6.1.2 Frequency stability with temperature

Test frequency: 1619.0kHz and 27499.9kHz

Mode: A1A

Line voltage: AC220V

Temperature (°C)	Frequency error (Hz)	
	1619.0kHz	27499.9kHz
-30	0.2	1.6
-20	0.2	1.6
-10	0.3	2.0
0	0.2	1.5
10	-0.1	-2.2
20	-0.2	-4.2
30	-0.3	-2.4
40	-0.2	-2.8
50	0.1	1.8

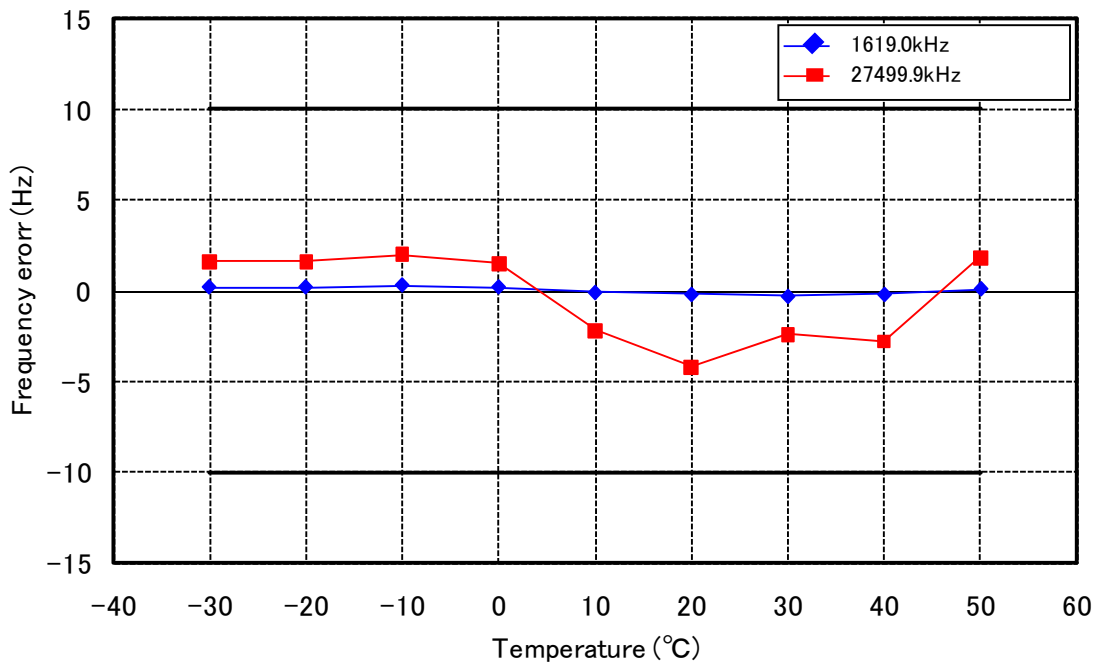

Fig. 2.6.1.2 Frequency stability with temperature

2.6.2 Frequency stability with primary supply voltage
[FCC §2.1055(d)(1),(3), §80.209(a)]

2.6.2.1 Test procedure

The Radio Equipment JSS-2500N was connected as shown in Fig.2.6.2.1.

The equipment was set for A1A. The frequency stability with varying line voltage was checked in power supply conditions of each AC operation and DC operation.

The AC voltage meter was used to measure the primary AC operation supply voltage. The DC voltage meter was used to measure the primary DC operation supply voltage.

(1) Measuring AC operation

The primary AC supply voltage was varied from 187 to 253 volts and the output frequency of the equipment under test in A1A mode was measured at both 1619.0kHz and 27499.9kHz

(2) Measuring DC operation

The primary DC supply voltage was varied from 20.4 to 27.6 volts and the output frequency of the equipment under test in A1A mode was measured at 2182.0kHz.

2.6.2.2 Test results

Test results are shown in table 2.6.2.2-1, table 2.6.2.2-2, Fig. 2.6.2.2-1, and Fig. 2.6.2.2-2.

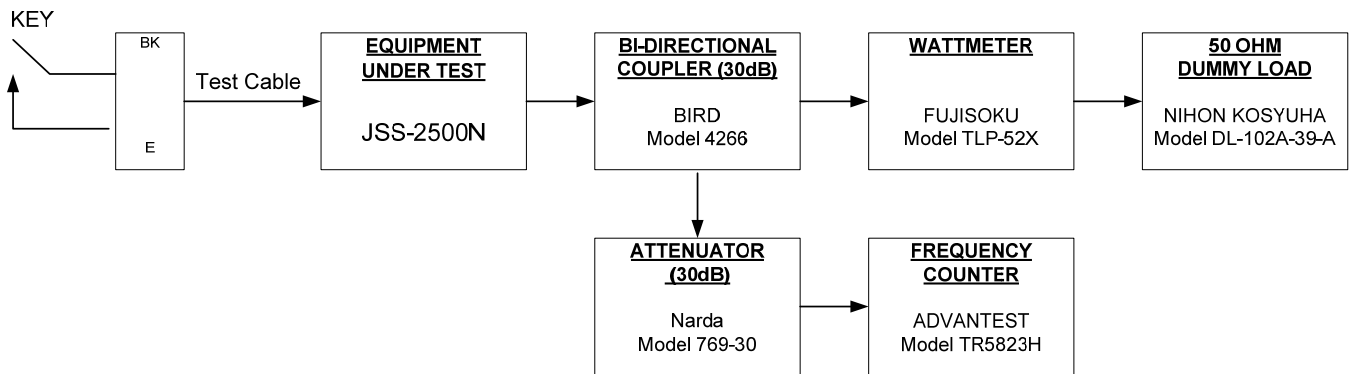

Fig. 2.6.2.1 Test set up for Frequency stability with primary supply voltage

Table 2.6.2.2-1 Frequency stability with primary supply voltage

Test frequency: 1619.0kHz and 27499.9kHz

Mode: A1A

Line voltage: AC220V

Voltage variation (%)	Supply voltage (V)	Frequency error (Hz)	
		1619.0kHz	27499.9kHz
-15	187	-0.2	-4.0
-10	198	-0.1	-4.2
-5	209	-0.2	-4.2
0	220	-0.2	-4.1
5	231	-0.2	-4.2
10	242	-0.1	-4.1
15	253	-0.2	-4.2

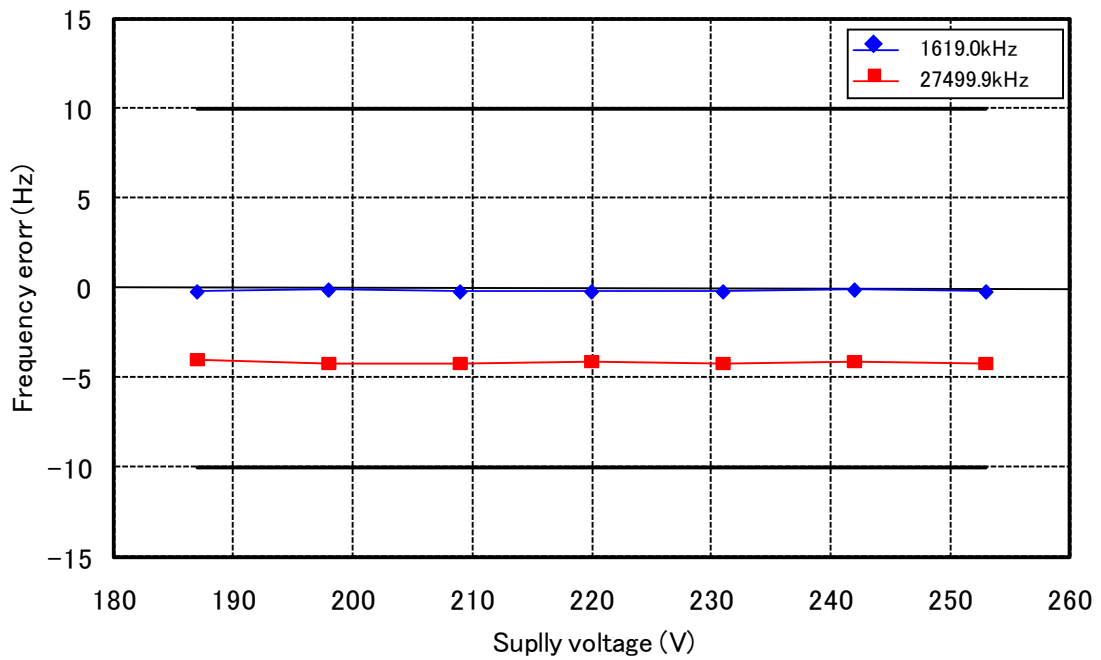

Fig. 2.6.2.2-1 Frequency stability with primary supply voltage

Table 2.6.2.2-2 Frequency stability with primary supply voltage

Test frequency: 2182.0kHz

Mode: A1A

Line voltage: DC24V

Voltage variation (%)	Supply voltage (V)	Frequency error (Hz)
-15	20.4	-0.2
-10	21.6	-0.1
-5	22.8	-0.2
0	24.0	-0.2
5	25.2	-0.2
10	26.4	-0.1
15	27.6	-0.2

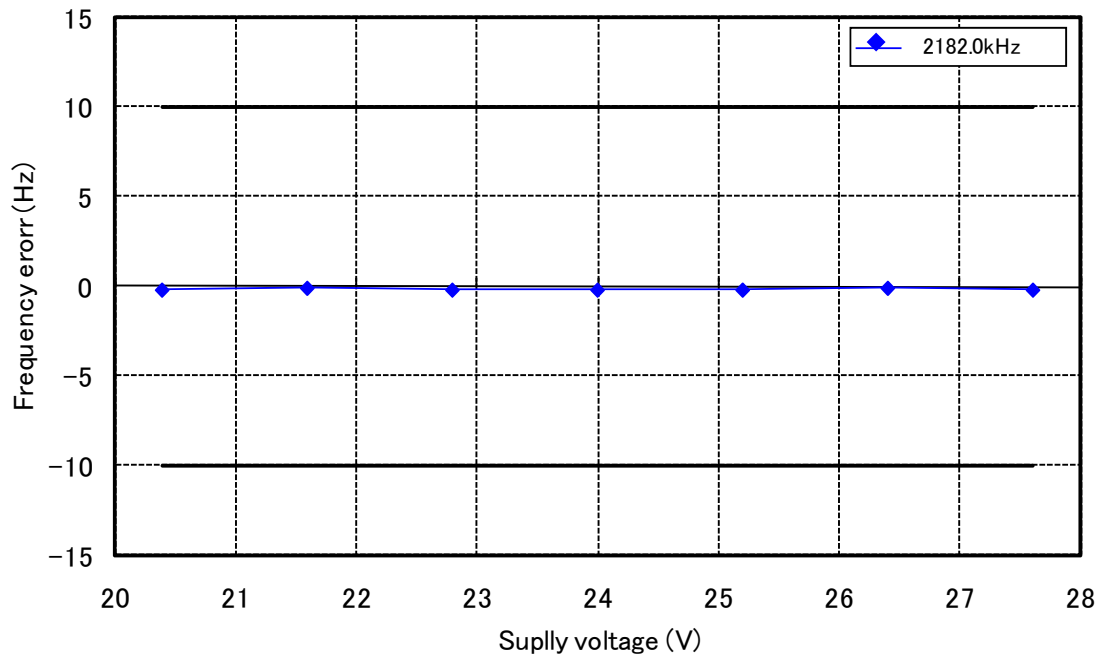

Fig. 2.6.2.2-2 Frequency stability with primary supply voltage

2.6.3 Frequency stability from cold start [FCC §2.1055(c)(1),(2), §80.209(a)]

The Radio Equipment JSS-2500N uses a TCXO as a reference generator from which the synthesizer derives all output frequencies. The reference generator is 0.3ppm over a temperature range from -30°C to $+55^{\circ}\text{C}$.

2.6.3.1 Test procedure

The Radio Equipment JSS-2500N was placed in an environmental chamber with control and the equipment was connected as shown in Fig.2.6.3.1.

The equipment was measured at -30°C to $+50^{\circ}\text{C}$ (10°C step) and was set for A1A mode.

Two test were measured, one at 1619kHz and one at the highest frequency that the transmitter operates, 27499.9kHz.

The temperature chamber was lowed to -30°C and the equipment was allowed to stabilize for one(1) hour with no primary power applied.

The primary power was then applied and the equipment was immediately keyed and the frequency was recorded. The equipment was keyed and frequency recorded at one-minute intervals up to 10 minutes, at two minutes intervals between 10 and 20 minutes, and then, the frequency was recorded every 5 minutes.

The primary power was then removed and the chamber temperature was raised in -20°C , and stabilized for 60 minutes after which the measurement was repeated.

2.6.3.2 Test results

Test results are shown from Table 2.6.3.2-1 to Table 2.6.3.2-9 and from Fig. 2.6.3.2-1 to Fig. 2.6.3.2-9.

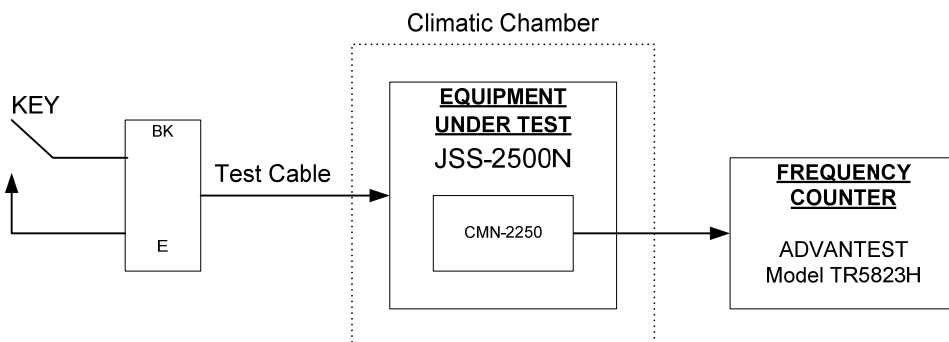

Fig. 2.6.3.1 Test set up for Frequency stability from cold start

Table 2.6.3.2-1 Frequency stability from cold start

Test frequency: 1619.0kHz and 27499.9kHz
 Mode: A1A
 Temperature: -30°C
 Line voltage: AC220V

Lapse of time (min)	Frequency error (Hz)	
	1619.0kHz	27499.9kHz
0	0.0	-0.5
1	0.1	1.4
2	0.2	1.6
3	0.2	1.5
4	0.2	1.6
5	0.1	1.7
6	0.2	1.6
7	0.2	1.6
8	0.2	1.4
9	0.1	1.6
10	0.2	1.5
12	0.2	1.6
14	0.2	1.5
16	0.2	1.2
18	0.2	1.4
20	0.2	1.6
25	0.2	1.8
30	0.2	1.4
35	0.2	1.4
40	0.1	1.7
45	0.2	1.4
50	0.2	1.4
55	0.2	1.2
60	0.2	1.5

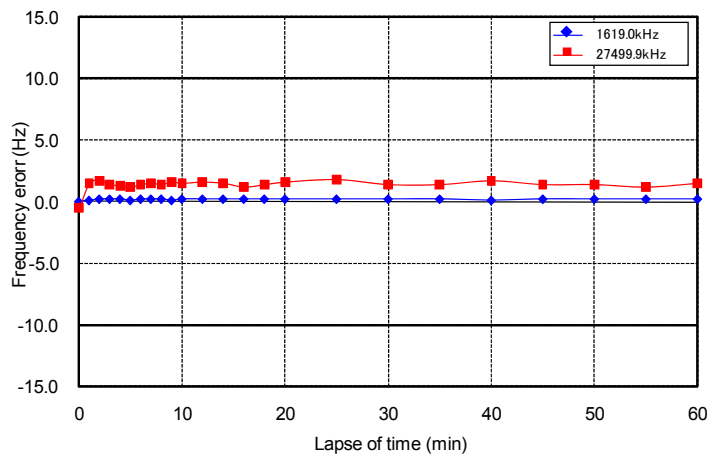

Fig. 2.6.3.2-1 Frequency stability from cold start

Table 2.6.3.2-2 Frequency stability from cold start

Test frequency: 1619.0kHz and 27499.9kHz

Mode: A1A

Temperature: -20°C

Line voltage: AC220V

Lapse of time (min)	Frequency error (Hz)	
	1619.0kHz	27499.9kHz
0	0.0	1.1
1	0.1	1.6
2	0.2	1.5
3	0.2	1.3
4	0.2	1.4
5	0.2	1.4
6	0.2	1.4
7	0.1	1.5
8	0.2	1.6
9	0.2	1.6
10	0.2	1.6
12	0.3	1.5
14	0.2	1.4
16	0.2	1.2
18	0.2	1.4
20	0.2	1.6
25	0.1	1.7
30	0.2	1.8
35	0.2	1.5
40	0.3	1.2
45	0.2	1.4
50	0.1	1.6
55	0.2	1.6
60	0.2	1.6

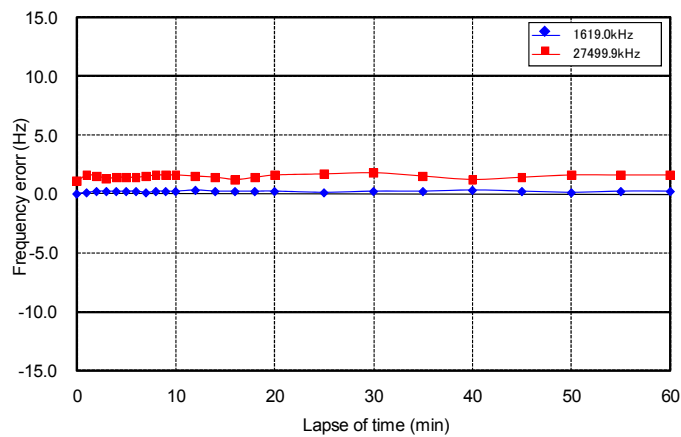

Fig. 2.6.3.2-2 Frequency stability from cold start

Table 2.6.3.2-3 Frequency stability from cold start

Test frequency: 1619.0kHz and 27499.9kHz
 Mode: A1A
 Temperature: -10°C
 Line voltage: AC220V

Lapse of time (min)	Frequency error (Hz)	
	1619.0kHz	27499.9kHz
0	0.1	1.2
1	0.2	1.5
2	0.3	1.6
3	0.2	1.3
4	0.2	1.3
5	0.3	1.4
6	0.2	1.5
7	0.2	1.5
8	0.3	1.7
9	0.2	1.8
10	0.2	1.9
12	0.3	2.0
14	0.2	2.1
16	0.1	2.1
18	0.2	2.0
20	0.2	1.9
25	0.3	1.8
30	0.2	2.1
35	0.3	2.1
40	0.2	2.0
45	0.3	2.1
50	0.3	1.9
55	0.3	2.0
60	0.3	2.0

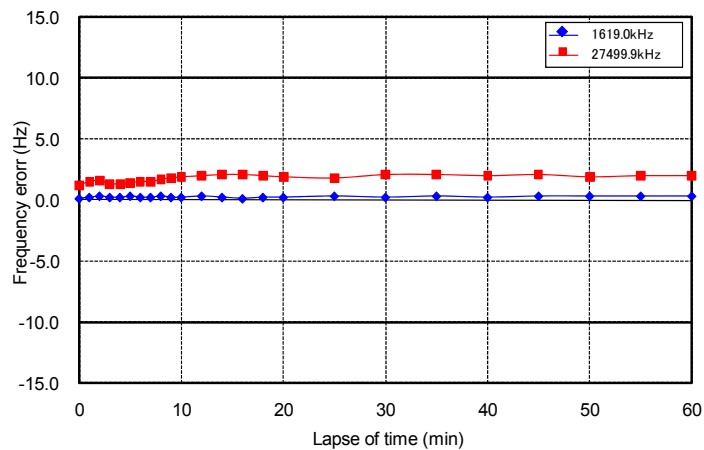

Fig. 2.6.3.2-3 Frequency stability from cold start

Table 2.6.3.2-4 Frequency stability from cold start

Test frequency: 1619.0kHz and 27499.9kHz
 Mode: A1A
 Temperature: 0°C
 Line voltage: AC220V

Lapse of time (min)	Frequency error (Hz)	
	1619.0kHz	27499.9kHz
0	-0.1	0.1
1	0.1	1.0
2	0.2	1.7
3	0.2	1.8
4	0.2	1.7
5	0.3	1.6
6	0.2	1.5
7	0.1	1.4
8	0.2	1.3
9	0.2	1.4
10	0.2	1.4
12	0.3	1.5
14	0.2	1.6
16	0.2	1.5
18	0.2	1.5
20	0.2	1.4
25	0.1	1.5
30	0.2	1.4
35	0.1	1.4
40	0.2	1.3
45	0.2	1.5
50	0.2	1.6
55	0.2	1.5
60	0.2	1.5

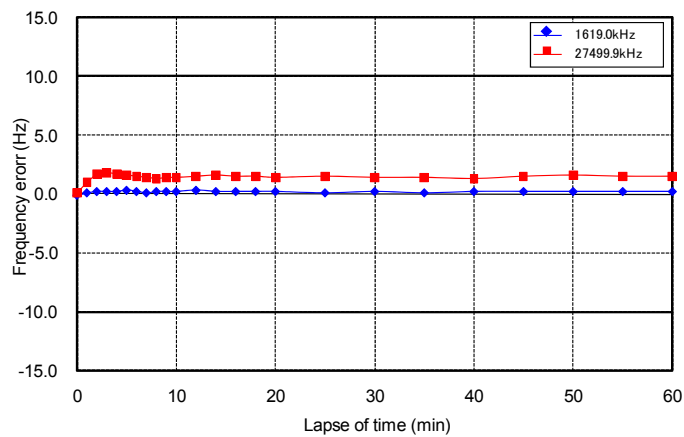

Fig. 2.6.3.2-4 Frequency stability from cold start

Table 2.6.3.2-5 Frequency stability from cold start

Test frequency: 1619.0kHz and 27499.9kHz
 Mode: A1A
 Temperature: 10°C
 Line voltage: AC220V

Lapse of time (min)	Frequency error (Hz)	
	1619.0kHz	27499.9kHz
0	0.1	0.5
1	0.0	0.2
2	0.0	-0.2
3	-0.1	-0.5
4	0.0	-1.0
5	-0.1	-1.5
6	0.0	-1.8
7	0.1	-2.0
8	0.0	-2.2
9	-0.1	-2.1
10	0.0	-2.0
12	-0.2	-2.0
14	-0.1	-1.9
16	-0.1	-1.8
18	-0.2	-2.0
20	-0.2	-2.1
25	-0.1	-2.2
30	-0.2	-2.1
35	-0.1	-2.2
40	-0.1	-2.2
45	-0.2	-2.1
50	-0.1	-2.2
55	-0.1	-2.2
60	-0.1	-2.2

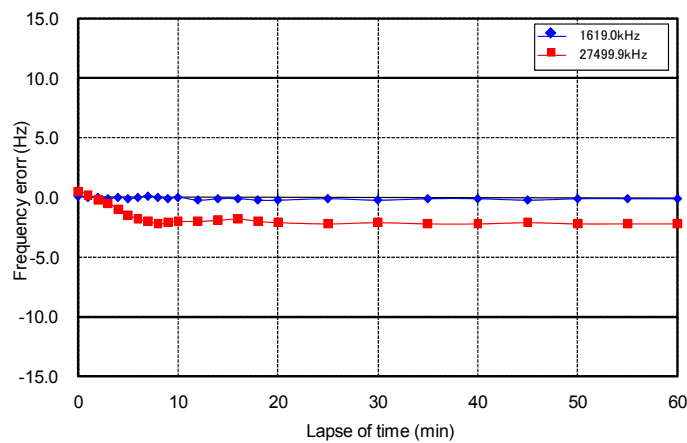

Fig. 2.6.3.2-5 Frequency stability from cold start

Table 2.6.3.2-6 Frequency stability from cold start

Test frequency: 1619.0kHz and 27499.9kHz
 Mode: A1A
 Temperature: 20°C
 Line voltage: AC220V

Lapse of time (min)	Frequency error (Hz)	
	1619.0kHz	27499.9kHz
0	0.1	-0.2
1	0.0	-1.2
2	-0.1	-2.0
3	-0.1	-2.9
4	-0.2	-3.4
5	-0.1	-3.6
6	-0.2	-3.9
7	-0.2	-4.1
8	-0.3	-4.2
9	-0.2	-4.3
10	-0.2	-4.3
12	-0.2	-4.2
14	-0.1	-4.1
16	-0.2	-4.2
18	-0.3	-4.2
20	-0.2	-4.3
25	-0.2	-4.3
30	-0.3	-4.2
35	-0.2	-4.1
40	-0.2	-4.1
45	-0.2	-4.2
50	-0.2	-4.2
55	-0.2	-4.2
60	-0.2	-4.2

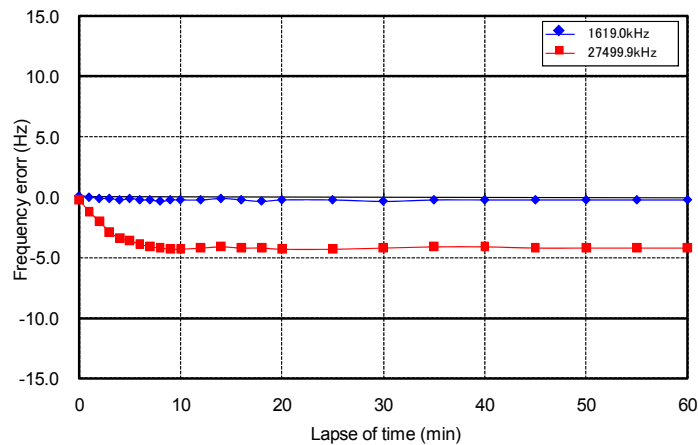

Fig. 2.6.3.2-6 Frequency stability from cold start

Table 2.6.3.2-7 Frequency stability from cold start

Test frequency: 1619.0kHz and 27499.9kHz
 Mode: A1A
 Temperature: 30°C
 Line voltage: AC220V

Lapse of time (min)	Frequency error (Hz)	
	1619.0kHz	27499.9kHz
0	0.0	-3.2
1	-0.1	-3.0
2	-0.2	-2.8
3	-0.2	-2.6
4	-0.2	-2.3
5	-0.3	-2.2
6	-0.2	-2.1
7	-0.2	-2.0
8	-0.3	-1.8
9	-0.3	-2.0
10	-0.4	-2.0
12	-0.3	-2.2
14	-0.3	-2.1
16	-0.4	-2.2
18	-0.3	-2.3
20	-0.3	-2.4
25	-0.4	-2.3
30	-0.3	-2.2
35	-0.3	-2.3
40	-0.3	-2.3
45	-0.3	-2.4
50	-0.3	-2.4
55	-0.4	-2.4
60	-0.3	-2.4

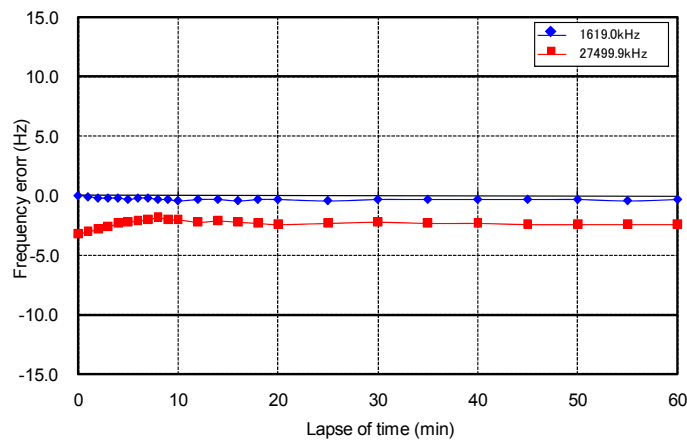

Fig. 2.6.3.2-7 Frequency stability from cold start

Table 2.6.3.2-8 Frequency stability from cold start

Test frequency: 1619.0kHz and 27499.9kHz
 Mode: A1A
 Temperature: 40°C
 Line voltage: AC220V

Lapse of time (min)	Frequency error (Hz)	
	1619.0kHz	27499.9kHz
0	0.1	-4.2
1	-0.1	-4.0
2	-0.1	-3.6
3	-0.2	-3.2
4	-0.2	-2.8
5	-0.3	-2.7
6	-0.2	-2.7
7	-0.2	-2.8
8	-0.1	-2.8
9	-0.2	-2.9
10	-0.2	-2.9
12	-0.3	-2.8
14	-0.2	-2.8
16	-0.2	-2.6
18	-0.1	-2.7
20	-0.1	-2.6
25	-0.2	-2.6
30	-0.2	-2.7
35	-0.2	-2.8
40	-0.3	-2.8
45	-0.2	-2.9
50	-0.2	-2.8
55	-0.2	-2.8
60	-0.2	-2.8

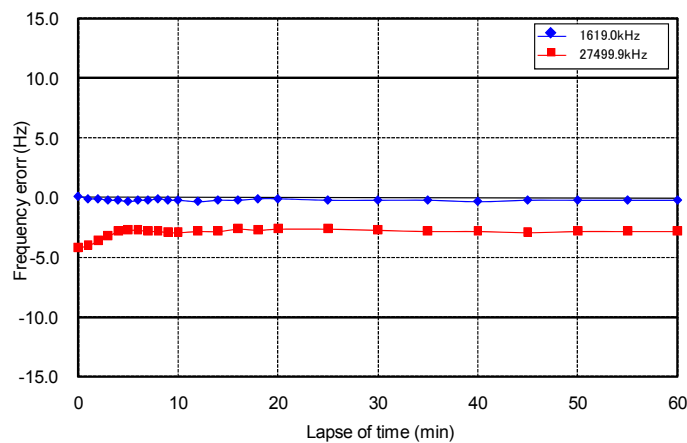

Fig. 2.6.3.2-8 Frequency stability from cold start

Table 2.6.3.2-9 Frequency stability from cold start

Test frequency: 1619.0kHz and 27499.9kHz
 Mode: A1A
 Temperature: 50°C
 Line voltage: AC220V

Lapse of time (min)	Frequency error (Hz)	
	1619.0kHz	27499.9kHz
0	0.0	-1.0
1	0.1	0.2
2	0.1	1.3
3	0.1	1.5
4	0.1	1.6
5	0.1	1.7
6	0.1	1.8
7	0.1	1.7
8	0.1	1.6
9	0.1	1.6
10	0.1	1.6
12	0.1	1.7
14	0.1	1.7
16	0.2	1.8
18	0.1	1.7
20	0.1	1.8
25	0.1	1.8
30	0.0	1.7
35	0.1	1.8
40	0.2	1.8
45	0.1	1.8
50	0.1	1.8
55	0.1	1.8
60	0.1	1.8

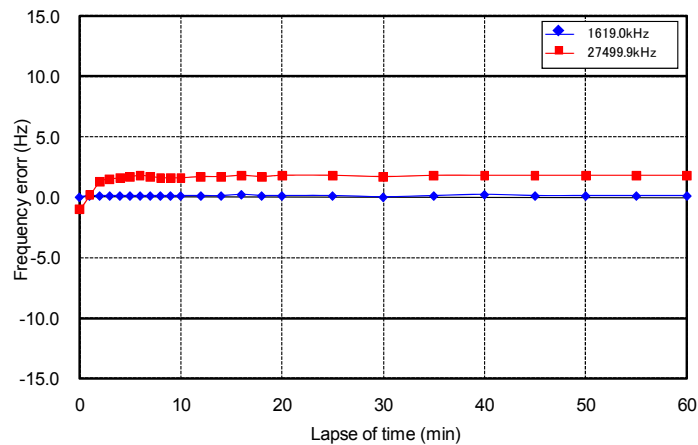

Fig. 2.6.3.2-9 Frequency stability from cold start

2.7 Interference
[FCC § 15.207, § 15.209]

2.7.1 Description of equipment

The Radio Equipment under test is JSS-2500/2500N which is consists of NTD-2500 Transceiver , NBD-2500 Power Supply, NFC-2500 Antenna Tuner, NCM-2150 Controller, NDZ-227 DTE, NDF-369 Keyboard and NKG-800 Printer.

2.7.2 Set up of testing

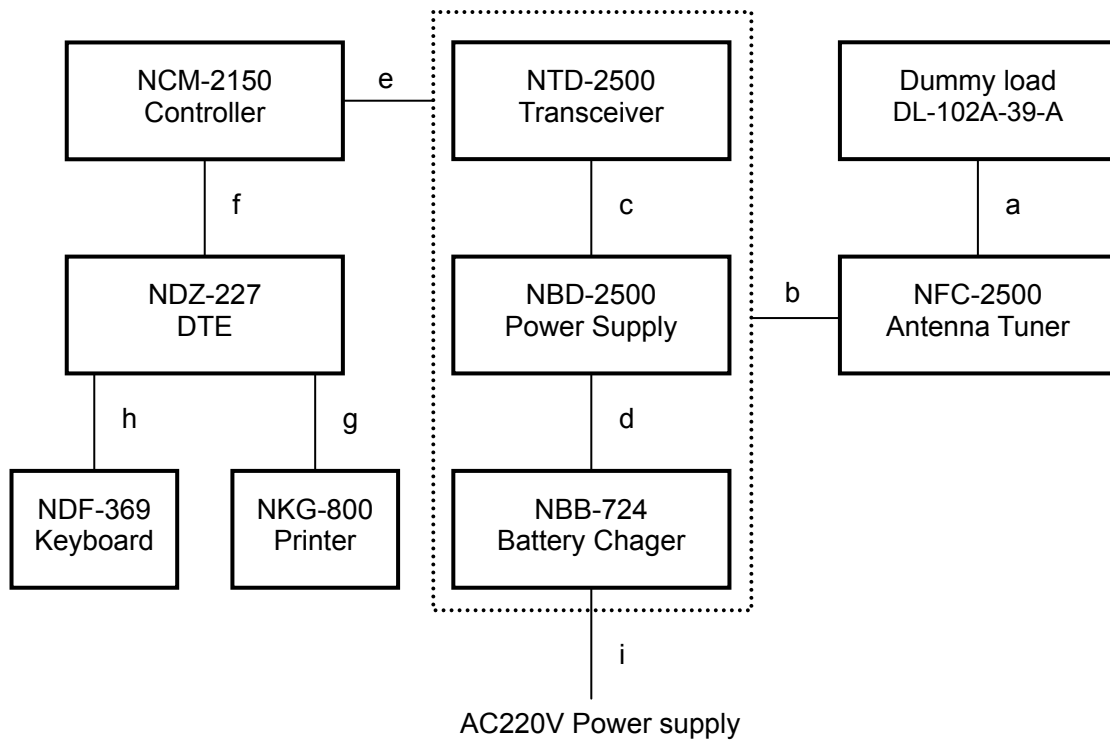

- a. RF coaxial cable
- b. RF coaxial cable and Control cable
- c. Power supply cable and Control cable
- d. Power supply cable
- e. Power supply cable and Control cable
- f. Power supply cable and Control cable
- g. Power supply cable and Printer cable
- h. Keyboard cable
- i. Power supply cable

2.7.3 Test procedure

The equipment was tested on the marine band at three frequencies, 2182.0kHz, 12290.0kHz and 26175.0kHz with J3E mode.

(1) Conducted interference

The line-impedance stabilization network (LISN) was connected between the equipment under test JSS-2500N and primary power supply.

The actual magnitude of any unwanted signals was measured with the spectrum analyzer and the test receiver. The level of each unwanted signal between 150kHz and 30MHz was noted. Conducted interference was calculated after adding the necessary cable losses and LISN factors.

(2) Radiated interference

The equipment was placed on the nonconductive platform (turntable) of EMI shielded room. The receiving antenna was located 3 meters away from the transmitter during testing. In order to investigate the maximum magnitude of any spurious signals, the turntable was rotated in every direction, the receiving antenna was moved up and down and the direction was changed into horizontal and vertical plane. The level of each spurious signal was measured with the spectrum analyzer between 9kHz and 2GHz and was calculated after adding the necessary cable losses and antenna correction factors.

*Test Place

Japan Radio Co., Ltd.

5-1-1 Shimorenjaku, Mitaka City Tokyo 181-8510, Japan

2.7.4 Test results

Test results are shown from Table 2.7.4-1 to Table 2.7.4-6 and from Fig. 2.7.4-1 to Fig. 2.7.4-6

Table 2.7.4-1 Conducted interference

Test frequency: 2182.0kHz
 Mode: J3E
 Line voltage: AC220V

Frequency (MHz)	Reading QP (dBuV)	LISN factor (dB)	Emission QP (dBuV)
0.199	32.3	10.2	42.5
3.096	26.0	10.8	36.8
4.453	26.0	11.0	37.0
10.277	32.5	11.8	44.3
19.531	22.0	12.8	34.8

Emission QP level = Reading QP level + LISN factor

Table 2.7.4-2 Conducted interference

Test frequency: 12290.0kHz
 Mode: J3E
 Line voltage: AC220V

Frequency (MHz)	Reading QP (dBuV)	LISN factor (dB)	Emission QP (dBuV)
0.201	36.5	10.2	46.7
4.226	25.9	11.0	36.9
10.277	33.1	11.7	44.8
10.643	30.0	11.7	41.7
19.544	21.5	12.8	34.3

Emission QP level = Reading QP level + LISN factor

Table 2.7.4-3 Conducted interference

Test frequency: 26175.0kHz
 Mode: J3E
 Line voltage: AC220V

Frequency (MHz)	Reading QP (dBuV)	LISN factor (dB)	Emission QP (dBuV)
0.199	34.8	10.2	45.0
4.035	25.6	11.0	36.6
10.265	32.3	11.7	44.0
13.749	22.4	12.2	34.6
20.339	20.9	12.9	33.8

Emission QP level = Reading QP level + LISN factor

Fig. 2.7.4-1 Conducted interference

Test frequency: 2182.0kHz
Mode: J3E

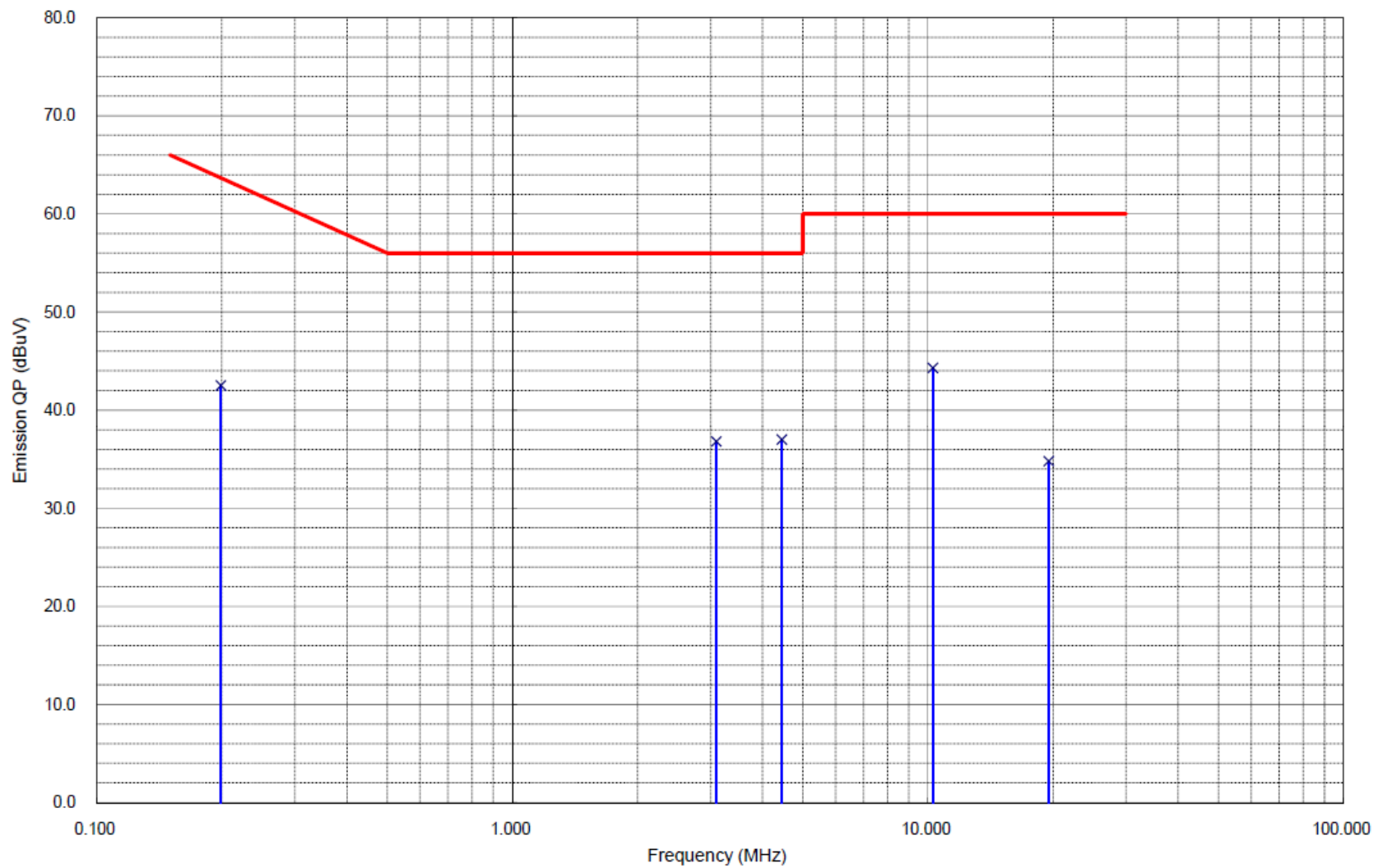

Fig. 2.7.4-2 Conducted interference

Test frequency: 12290.0kHz

Mode: J3E

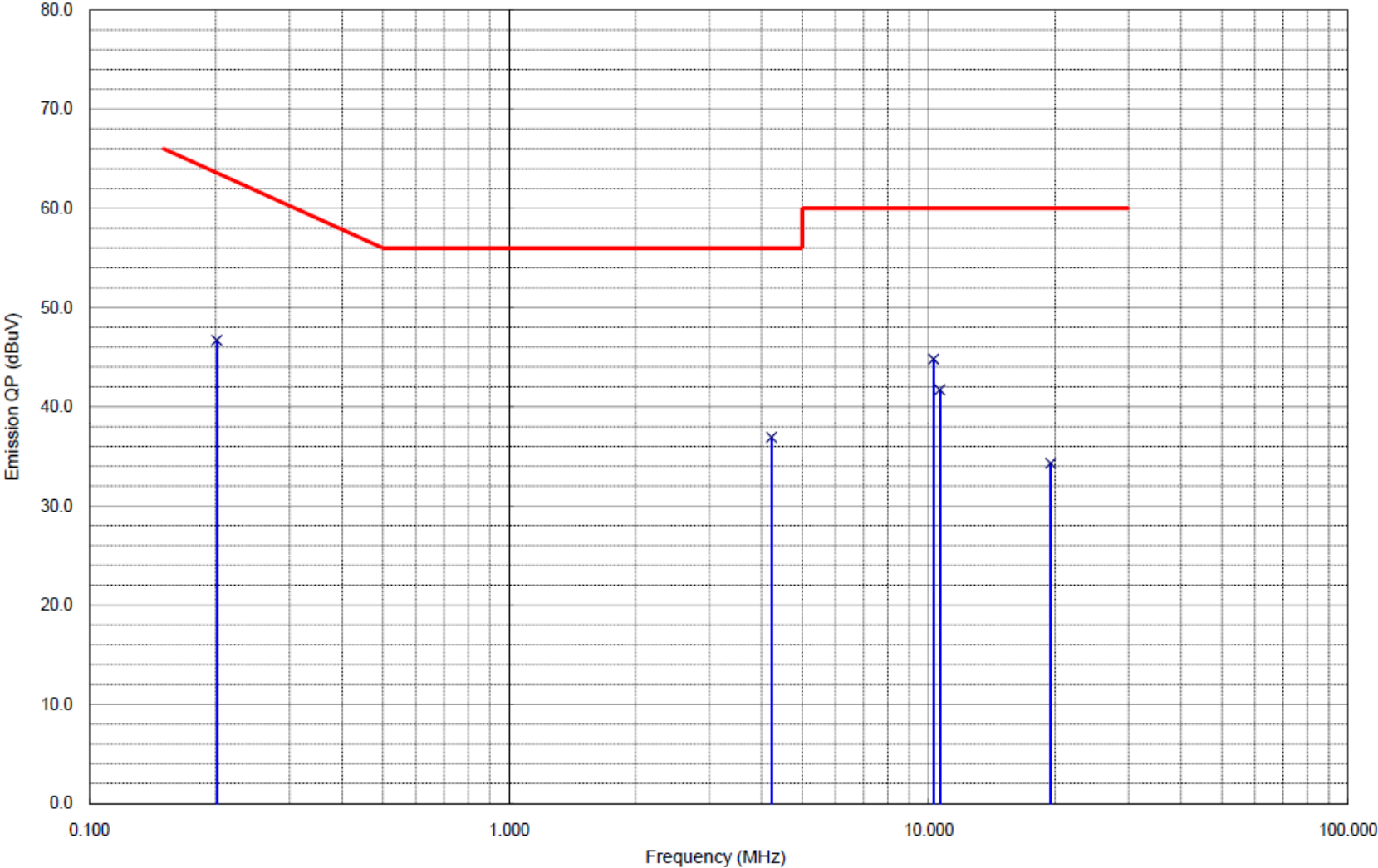

Fig. 2.7.4-3 Conducted interference

Test frequency: 26175.0kHz
Mode: J3E

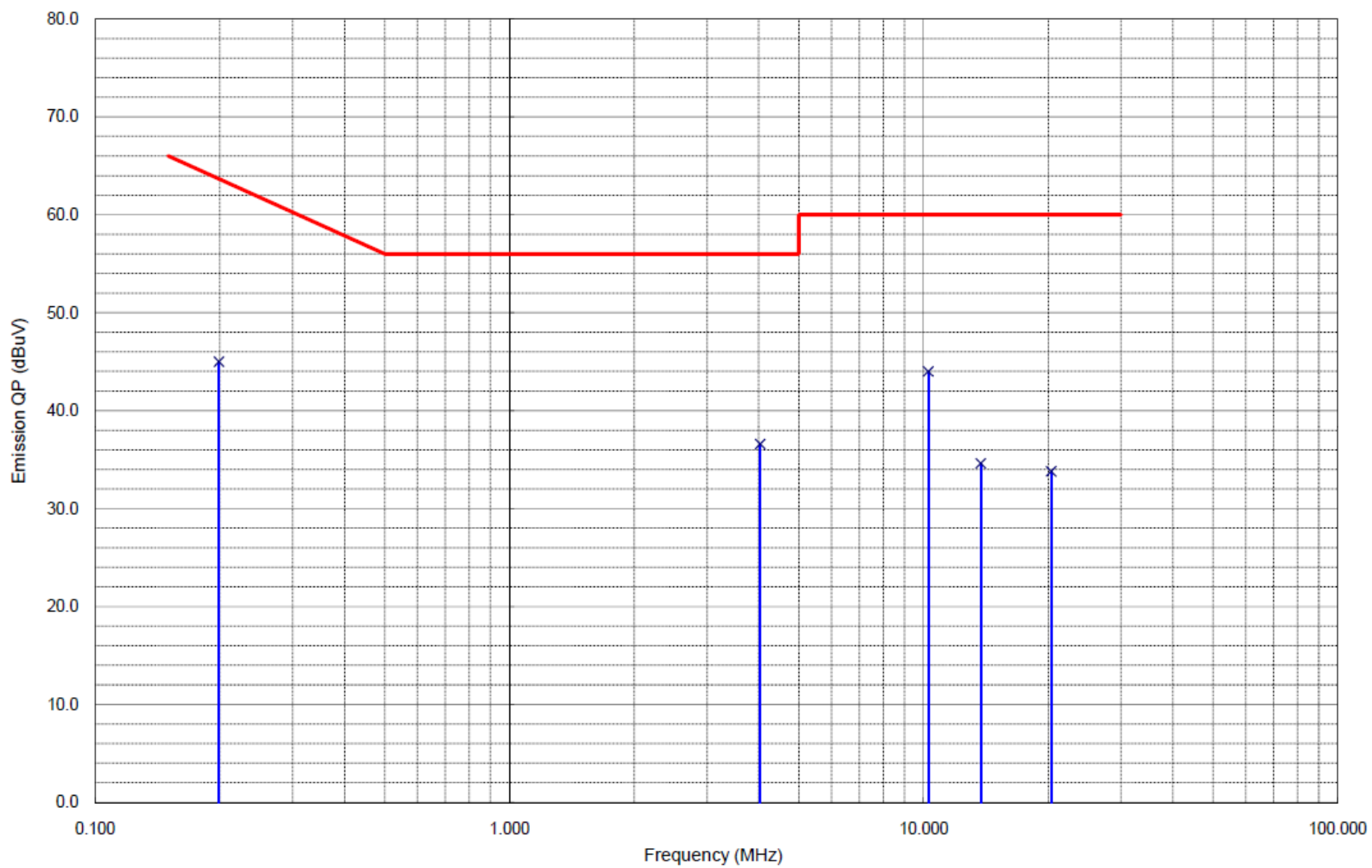

Table 2.7.4-4 Radiated interference

Test frequency: 2182.0kHz

Mode: J3E

Line voltage: AC220V

Frequency (MHz)	Reading (dBUV)		Calibration Factor (dB)	Emission Level (dBUV/m)
	Horizontal Plane	Vertical Plane		
0.035	48.8	----	19.1	67.9
0.058	----	38.8	19.0	57.8
0.199	25.9	----	18.9	44.8
0.398	----	23.7	18.9	42.6
1.134	----	19.9	18.9	38.8
398.000	12.1	----	20.5	32.6
1017.000	52.6	----	-15.5	37.1
1106.000	49.6	----	-15.0	34.6
1280.000	----	50.6	-14.0	36.6
1600.000	----	46.8	-12.1	34.7

Emission level = Reading level + Calibration factor

Calibration factor = Antenna factor + Cable loss – Amplifier gain

Fig. 2.7.4-4 Radiated interference

Test frequency: 2182.0kHz
Mode: J3E

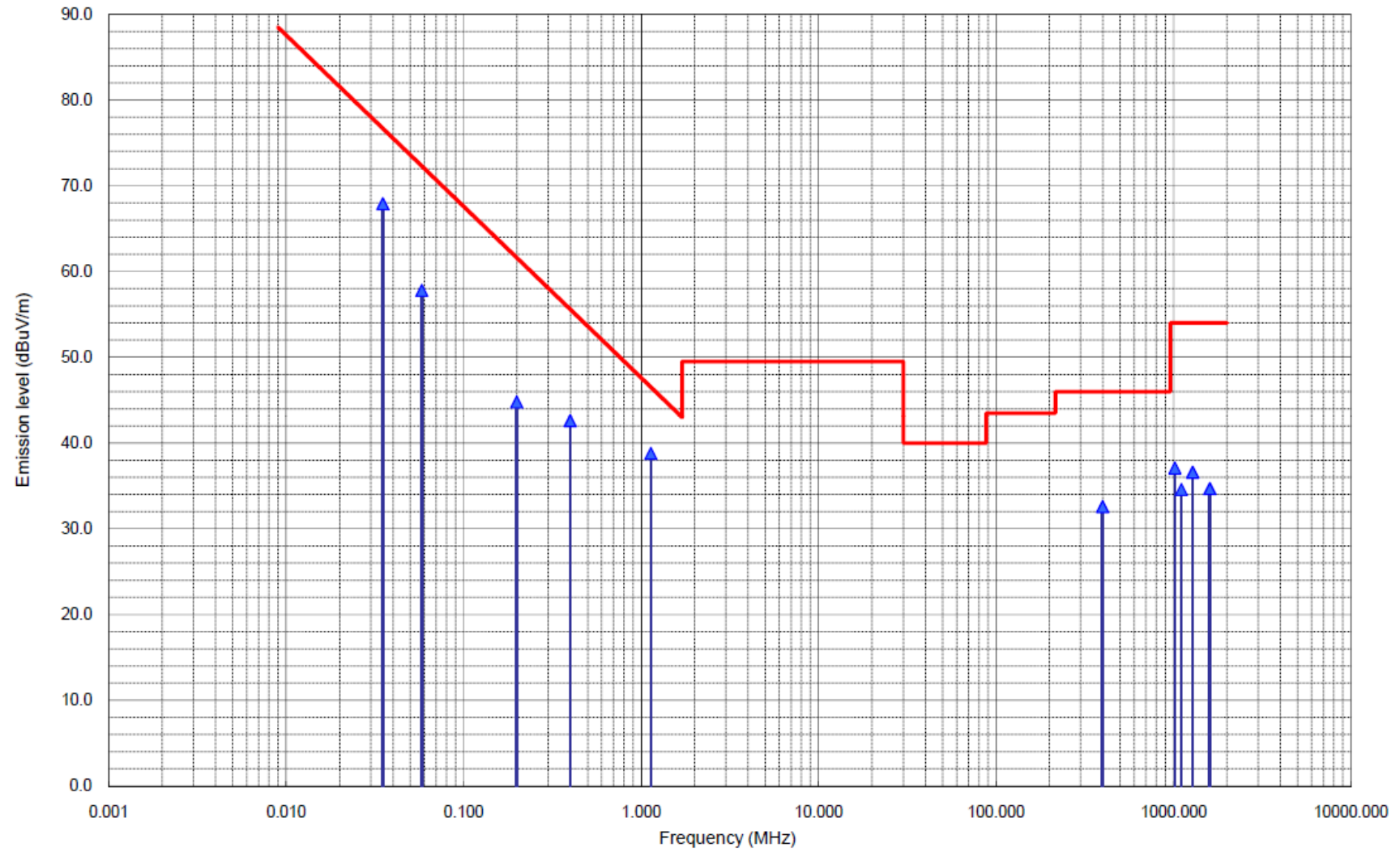

Table 2.7.4-5 Radiated interference

Test frequency: 12290.0kHz

Mode: J3E

Line voltage: AC220V

Frequency (MHz)	Reading (dBUV)		Calibration Factor (dB)	Emission Level (dBUV/m)
	Horizontal Plane	Vertical Plane		
0.036	48.8	----	19.1	67.9
0.058	----	35.8	19.0	54.8
0.199	----	23.5	18.9	42.4
0.399	----	22.9	18.9	41.8
1.134	----	21.5	18.9	40.4
298.920	6.6	----	23.4	30.0
398.000	12.7	----	20.5	33.2
1017.000	52.7	----	-15.5	37.2
1106.000	49.6	----	-15.0	34.6
1280.000	----	49.7	-14.0	35.7

Emission level = Reading level + Calibration factor

Calibration factor = Antenna factor + Cable loss – Amplifier gain

Fig. 2.7.4-5 Radiated interference

Test frequency: 12290.0kHz
Mode: J3E

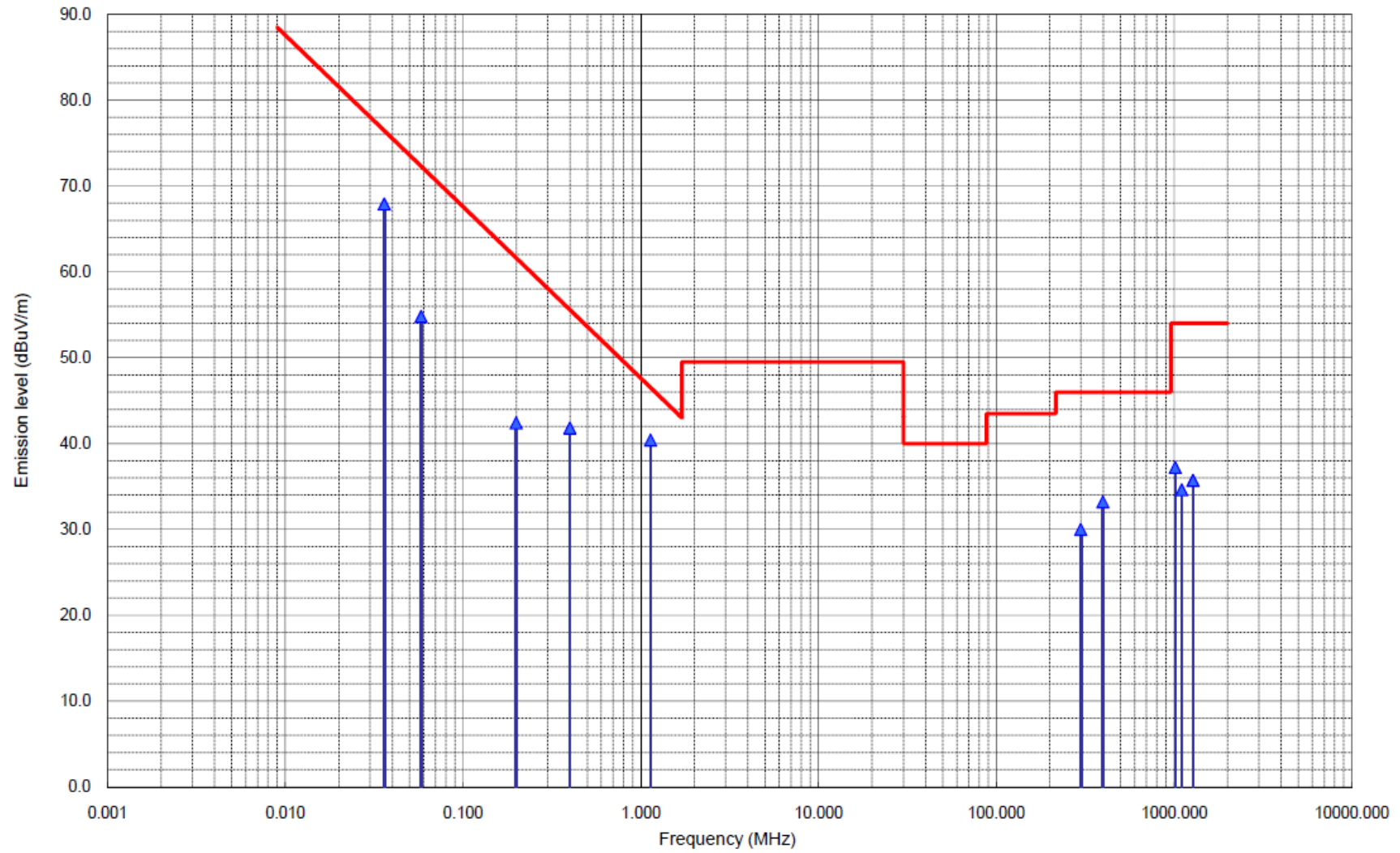

Table 2.7.4-6 Radiated interference

Test frequency: 26175.0kHz

Mode: J3E

Line voltage: AC220V

Frequency (MHz)	Reading (dBUV)		Calibration Factor (dB)	Emission Level (dBUV/m)
	Horizontal Plane	Vertical Plane		
0.030	41.1	----	19.1	60.2
0.048	----	39.0	19.1	58.1
0.636	----	22.2	18.9	41.1
1.134	----	21.4	18.9	40.3
398.000	12.3	----	20.5	32.8
1017.000	53.3	----	-15.5	37.8
1105.000	49.6	----	-15.0	34.6
1280.000	----	50.1	-14.0	36.1
1600.000	----	46.7	-12.1	34.6
1685.000	----	46.4	-11.2	35.2

Emission level = Reading level + Calibration factor

Calibration factor = Antenna factor + Cable loss – Amplifier gain

Fig. 2.7.4-6 Radiated interference

Test frequency: 26175.0kHz
Mode: J3E

