

TEST RESULT FOR FCC CERTIFICATION

Purpose of test : Certify JSB-196GM
Grantee's type or model No. : JSB-196GM
Drawing, specification or exhibit : FCC Part 2,15 and 80
Quantity of item tested : One (1) of the above type
Abstract : Refer to result sections
Date tested completed : June 23, 2000
Test place : Japan Radio Co., Ltd
Mitaka Plant
5-1-1, Shimorenjyaku,
Mitaka City, Tokyo
181-8510 Japan

Tested by: T. Negoro
T.Negoro

Checked by: F. Koide
F.Koide

Approved by: E. Kobayashi
E.Kobayashi

INDEX

1. General
2. Test for requirement
 - 2.1 RF power output and power amplifier operating parameters
 - 2.2 Modulation characteristics
 - 2.2.1 Frequency response of audio modulating circuit
 - 2.2.2 Modulation limiting characteristics
 - 2.2.3 Overall transmitter audio frequency response
 - 2.3 Occupied bandwidth
 - 2.4 Spurious emissions at antenna terminal
 - 2.5 Field strength of spurious radiation
 - 2.6 Frequency stability
 - 2.6.1 Frequency stability with temperature
 - 2.6.2 Frequency stability with primary supply voltage
 - 2.6.3 Frequency stability from cold start
 - 2.7 Interference

1. General

1.1 Normal test conditions

Power source	: 24.0V DC
Temperature range	: +15 to +30
Relative humidity	: 20% to 75%

1.2 Environmental test conditions

Power source	
High voltage	: 27.6V DC (115%)
Normal voltage	: 24.0V DC (100%)
Low voltage	: 20.4V DC (85%)

Temperature range	
Low temperature	: -30
High temperature	: +50

1.3 Antenna impedance: 50 ohm

1.4 Modulation input impedance: 600 ohm

1.5 Equipment under test JSB-196GM block set up: Fig. 1.5-1

1.6 List of measurement instruments: Table 1.6

1.5 Equipment under test JSB-196GM block set up

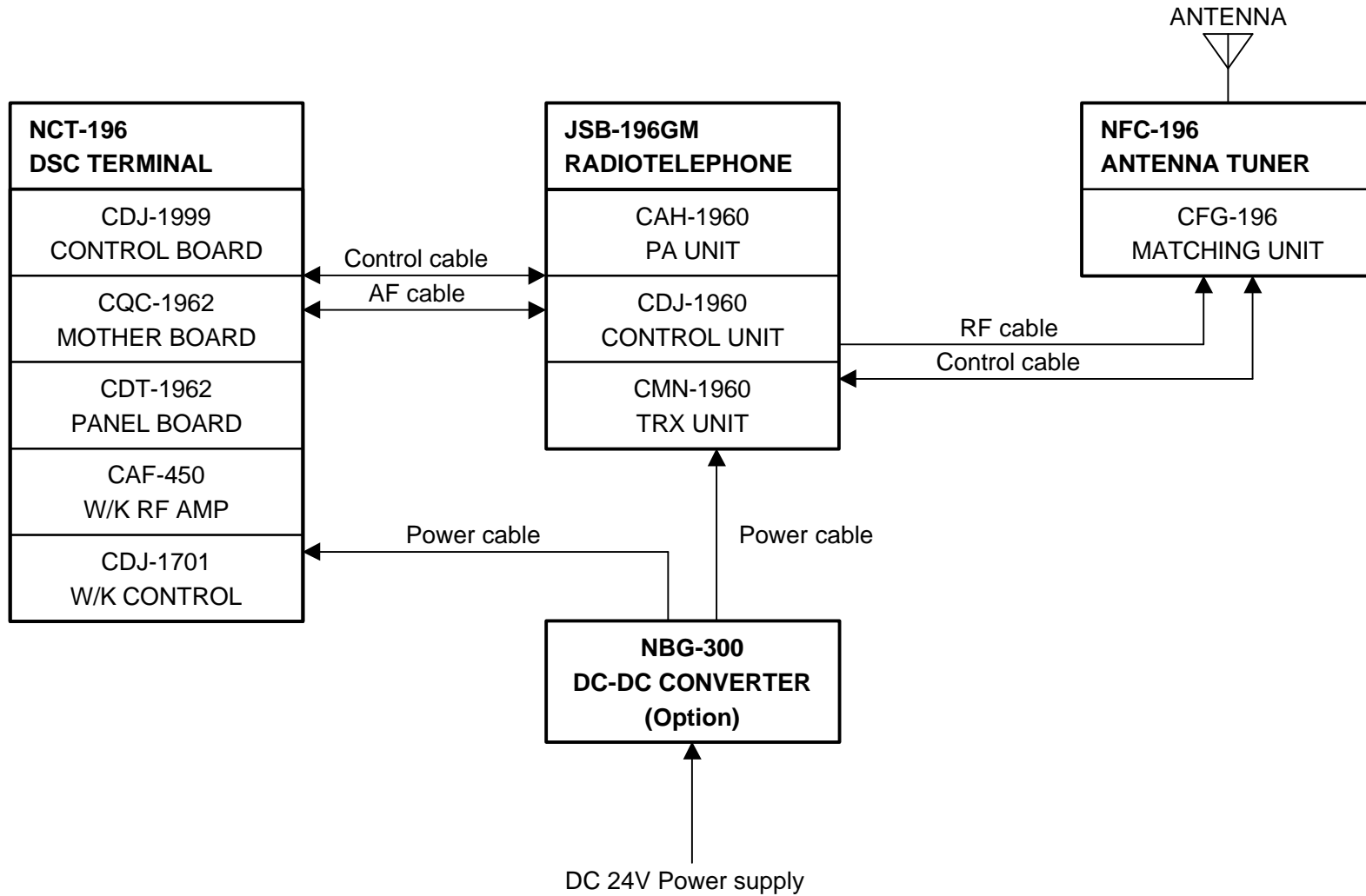

Fig. 1.5-1

1.6 List of measuring instruments

The measuring instruments used for these tests are maintained in good working condition and are calibrated on routine basis every six months.

Table 1.6

Article	Model	Serial No	Manufacturer
Regulated DC power supply	35-60L	1200011	Kikusui Electronics Corp.
DC voltage meter	2051	03953U	Yokogawa Electric Works, Ltd
Two tone oscillator	TF2005R	351225/10	Marconi
AF Attenuator	STA-114	Z4463	Tokyo KO-ON Denpa Co.,Ltd
Frequency counter	TR5825	01950011	Advantest
BI-Directional coupler	4266	-	Bird
Wattmeter	TLP-52X	15837	Fujisoku
Spectrum analyzer	8563A	-	HP
Spectrum analyzer	3582A	1809A03985	HP
Storage oscilloscope	9354TM	9354 2547	Lecroy
50 ohm dummy load	8860	2715	Bird

2. Test for requirement

2.1 RF power output and power amplifier operating parameters [FCC § 2.1046(a),(b), § 80.215(d)]

2.1.1 Test procedure

The Radio Equipment JSB-196GM was connected as shown in Fig. 2.1.1-1.

Output power: 1.6 – 4MHz, 100W
4-27.5MHz, 150W

Power supply conditions: DC 24V and ± 15%

The equipment was tested on each of marine bands in the transmitter frequency range with J3E, A1A and F1B (DSC) modes, on the 2MHz marine band at two frequencies with J3E, A1A and F1B modes.

The modulation in J3E mode was signals of 400Hz and 1800Hz applied simultaneously to the microphone input. The levels of the tones were adjusted to produce equal output power. The level of the input signal increased until the transmitter rated output power, and then increased by 10dB as shown in Fig. 2.2.2.2-1 of the Modulation limiting characteristics test.

The transmit output in A1A mode was measured with the continuous key down.

F1B mode was modulated with a continuous dot pattern by the DSC unit. DSC unit audio lines connected the JSB-196GM line input terminal. The audio input signal pass over the modulation limiting circuits.

Current and voltage level into the final power amplifier were measured with the data display function of the JSB-196GM. (Menu item No.18)

Readings were also taken with no audio input and carrier suppression was measured at this time with the spectrum analyzer.

Method of calculating the J3E output power according to ITU-R Recommendation 326-2. We read the power of the wattmeter, then calculated the output power by the following formula.

$$\text{Output power} = \text{mean power} \times \left[\frac{\text{Deflection of oscilloscope at two-signal}}{\text{Deflection of oscilloscope at one signal}} \right]^2$$

(Watt)

2.1.2 Test results

Test results are shown from Table 2.1.2-1 to Table 2.1.2-3.

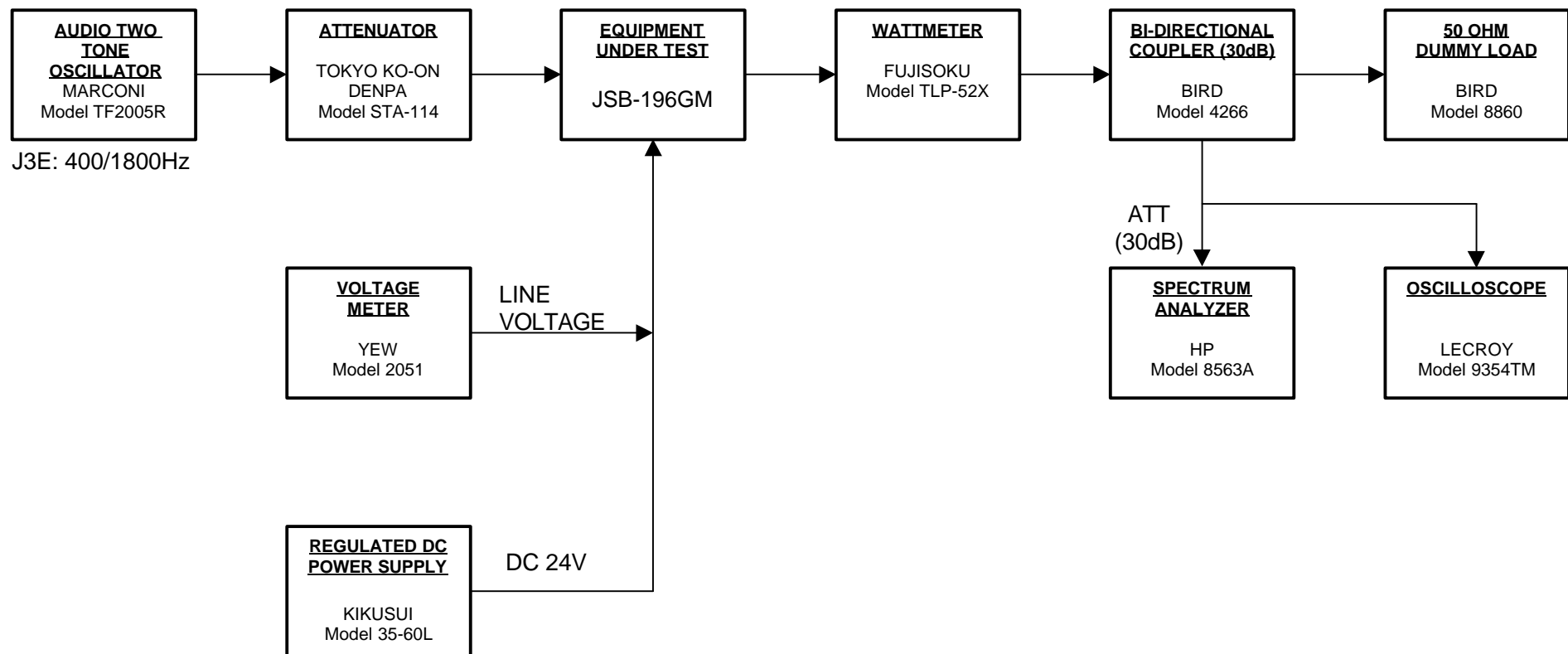

Fig. 2.1.1-1 Test set up for Power output and amplifier operating parameters

Table 2.1.2-1 Test results (DC 24.0V)

RF power output and power amplifier operating parameters (cont'd)

(1/2)

Frequency (kHz)	Emission	Output (W)	Final Voltage (V)	Final Current (A)	Modulation	Modulation Level (Vpep)	Carrier below pep (dB)
1619.0	J3E	100	13.1	15.7	2-Tone	0.03	----
		0	13.6	0.8	None	----	-90
	A1A	100	12.7	22.2	----	----	----
	F1B	100	12.7	22.0	Dot signal	2.2	----
2182.0	J3E	100	13.2	13.4	2-Tone	0.03	----
		0	13.6	0.8	None	----	-90
	A1A	100	12.8	19.0	----	----	----
	F1B	100	12.8	18.7	Dot signal	2.2	----
2187.5	J3E	100	13.2	13.2	2-Tone	0.03	----
		0	13.6	0.5	None	----	-90
	A1A	100	12.8	18.8	----	----	----
	F1B	95	12.9	18.0	Dot signal	2.2	----
2830.0	J3E	100	13.3	11.7	2-Tone	0.03	----
		0	13.6	0.8	None	----	-90
	A1A	100	12.9	16.4	----	----	----
	F1B	100	12.9	16.3	Dot signal	2.2	----
3258.0	J3E	100	13.3	11.5	2-Tone	0.03	----
		0	13.6	0.8	None	----	-90
	A1A	100	12.9	16.0	----	----	----
	F1B	100	12.9	16.0	Dot signal	2.2	----
4112.0	J3E	150	13.0	18.5	2-Tone	0.03	----
		0	13.6	0.8	None	----	-90
	A1A	150	12.5	25.9	----	----	----
	F1B	150	12.5	26.0	Dot signal	2.2	----
6212.0	J3E	150	13.1	16.5	2-Tone	0.03	----
		0	13.6	0.8	None	----	-90
	A1A	150	12.6	23.7	----	----	----
	F1B	150	12.6	23.8	Dot signal	2.2	----
8238.0	J3E	145	13.2	14.9	2-Tone	0.03	----
		0	13.6	0.8	None	----	-90
	A1A	150	12.8	21.3	----	----	----
	F1B	150	12.8	21.2	Dot signal	2.2	----
12339.0	J3E	150	13.2	15.1	2-Tone	0.03	----
		0	13.6	0.8	None	----	-90
	A1A	150	12.7	21.9	----	----	----
	F1B	150	12.6	22.0	Dot signal	2.2	----
16525.0	J3E	145	13.0	18.6	2-Tone	0.03	----
		0	13.6	0.8	None	----	-90
	A1A	150	12.5	26.6	----	----	----
	F1B	150	12.5	26.5	Dot signal	2.2	----

Table 2.1.2-1 Test results (DC 24.0V)

RF power output and power amplifier operating parameters (cont'd)

(2/2)

Frequency (kHz)	Emission	Output (W)	Final Voltage (V)	Final Current (A)	Modulation	Modulation Level (V _{pep})	Carrier Below pep (dB)
22093.0	J3E	145	13.2	14.6	2-Tone	0.03	----
		0	13.6	0.8	None	----	-90
	A1A	150	12.8	20.9	----	----	----
	F1B	150	12.9	20.9	Dot signal	2.2	----
26175.0	J3E	150	13.1	15.4	2-Tone	0.03	----
		0	13.6	0.8	None	----	-90
	A1A	150	12.8	22.0	----	----	----
	F1B	150	12.8	22.0	Dot signal	2.2	----

Table 2.1.2-2 Test results (DC 20.4V)

RF power output and power amplifier operating parameters (cont'd)

(1/2)

Frequency (kHz)	Emission	Output (W)	Final Voltage (V)	Final Current (A)	Modulation	Modulation Level (V _{pep})	Carrier below pep (dB)
1619.0	J3E	100	13.1	15.7	2-Tone	0.03	----
		0	13.6	0.8	None	----	-90
	A1A	100	12.7	22.2	----	----	----
	F1B	95	12.7	21.4	Dot signal	2.2	----
2182.0	J3E	100	13.2	13.4	2-Tone	0.03	----
		0	13.6	0.8	None	----	-90
	A1A	100	12.8	19.0	----	----	----
	F1B	95	12.8	18.1	Dot signal	2.2	----
2187.5	J3E	100	13.2	13.2	2-Tone	0.03	----
		0	13.6	0.5	None	----	-90
	A1A	100	12.8	18.8	----	----	----
	F1B	95	12.9	18.0	Dot signal	2.2	----
2830.0	J3E	100	13.3	11.7	2-Tone	0.03	----
		0	13.6	0.8	None	----	-90
	A1A	100	12.9	16.4	----	----	----
	F1B	100	12.9	16.3	Dot signal	2.2	----
3258.0	J3E	100	13.3	11.5	2-Tone	0.03	----
		0	13.6	0.8	None	----	-90
	A1A	100	12.9	16.0	----	----	----
	F1B	95	12.9	15.1	Dot signal	2.2	----
4112.0	J3E	148	13.0	18.2	2-Tone	0.03	----
		0	13.6	0.8	None	----	-90
	A1A	150	12.5	25.9	----	----	----
	F1B	148	12.6	25.5	Dot signal	2.2	----
6212.0	J3E	150	13.1	16.5	2-Tone	0.03	----
		0	13.6	0.8	None	----	-90
	A1A	148	12.6	23.5	----	----	----
	F1B	150	12.6	24.1	Dot signal	2.2	----
8238.0	J3E	145	13.2	14.9	2-Tone	0.03	----
		0	13.6	0.8	None	----	-90
	A1A	150	12.8	21.3	----	----	----
	F1B	150	12.8	21.2	Dot signal	2.2	----
12339.0	J3E	150	13.2	15.1	2-Tone	0.03	----
		0	13.6	0.8	None	----	-90
	A1A	150	12.6	22.1	----	----	----
	F1B	150	12.6	22.0	Dot signal	2.2	----
16525.0	J3E	148	13.0	19.0	2-Tone	0.03	----
		0	13.6	0.8	None	----	-90
	A1A	150	12.5	26.6	----	----	----
	F1B	150	12.5	26.5	Dot signal	2.2	----

Table 2.1.2-2 Test results (DC 20.4V)

RF power output and power amplifier operating parameters (cont'd)

(2/2)

Frequency (kHz)	Emission	Output (W)	Final Voltage (V)	Final Current (A)	Modulation	Modulation Level (V _{pep})	Carrier Below pep (dB)
22093.0	J3E	145	13.2	14.6	2-Tone	0.03	----
		0	13.6	0.8	None	----	-90
	A1A	150	12.8	20.9	----	----	----
	F1B	145	12.9	19.8	Dot signal	2.2	----
26175.0	J3E	150	13.1	15.4	2-Tone	0.03	----
		0	13.6	0.8	None	----	-90
	A1A	150	12.8	22.0	----	----	----
	F1B	150	12.8	22.1	Dot signal	2.2	----

Table 2.1.2-3 Test results (DC 27.6V)

RF power output and power amplifier operating parameters (cont'd)

(1/2)

Frequency (kHz)	Emission	Output (W)	Final Voltage (V)	Final Current (A)	Modulation	Modulation Level (V _{pep})	Carrier below pep (dB)
1619.0	J3E	100	13.1	15.7	2-Tone	0.03	----
		0	13.6	0.8	None	----	-90
	A1A	100	12.7	22.2	----	----	----
	F1B	100	12.7	22.0	Dot signal	2.2	----
2182.0	J3E	100	13.2	13.4	2-Tone	0.03	----
		0	13.6	0.8	None	----	-90
	A1A	100	12.8	19.0	----	----	----
	F1B	100	12.8	18.7	Dot signal	2.2	----
2187.5	J3E	100	13.2	13.2	2-Tone	0.03	----
		0	13.6	0.5	None	----	-90
	A1A	100	12.8	18.8	----	----	----
	F1B	95	12.9	18.0	Dot signal	2.2	----
2830.0	J3E	100	13.3	11.7	2-Tone	0.03	----
		0	13.6	0.8	None	----	-90
	A1A	100	12.9	16.4	----	----	----
	F1B	105	12.8	17.3	Dot signal	2.2	----
3258.0	J3E	100	13.3	11.5	2-Tone	0.03	----
		0	13.6	0.8	None	----	-90
	A1A	100	12.9	16.0	----	----	----
	F1B	105	12.8	17.2	Dot signal	2.2	----
4112.0	J3E	150	13.0	18.3	2-Tone	0.03	----
		0	13.6	0.8	None	----	-90
	A1A	150	12.5	25.9	----	----	----
	F1B	145	12.6	25.0	Dot signal	2.2	----
6212.0	J3E	150	13.1	16.5	2-Tone	0.03	----
		0	13.6	0.8	None	----	-90
	A1A	150	12.6	24.0	----	----	----
	F1B	150	12.6	24.1	Dot signal	2.2	----
8238.0	J3E	145	13.2	14.9	2-Tone	0.03	----
		0	13.6	0.8	None	----	-90
	A1A	150	12.8	21.3	----	----	----
	F1B	150	12.8	21.2	Dot signal	2.2	----
12339.0	J3E	145	13.2	14.9	2-Tone	0.03	----
		0	13.6	0.8	None	----	-90
	A1A	150	12.6	22.1	----	----	----
	F1B	150	12.6	22.0	Dot signal	2.2	----
16525.0	J3E	150	13.0	19.4	2-Tone	0.03	----
		0	13.6	0.8	None	----	-90
	A1A	150	12.5	26.6	----	----	----
	F1B	150	12.5	26.5	Dot signal	2.2	----

Table 2.1.2-3 Test results (DC 27.6V)

RF power output and power amplifier operating parameters (cont'd)

(2/2)

Frequency (kHz)	Emission	Output (W)	Final Voltage (V)	Final Current (A)	Modulation	Modulation Level (V _{pep})	Carrier Below pep (dB)
22093.0	J3E	145	13.2	14.6	2-Tone	0.03	----
		0	13.6	0.8	None	----	-90
	A1A	150	12.8	20.9	----	----	----
	F1B	150	12.8	20.7	Dot signal	2.2	----
26175.0	J3E	150	13.1	15.4	2-Tone	0.03	----
		0	13.6	0.8	None	----	-90
	A1A	145	12.7	21.0	----	----	----
	F1B	145	12.7	21.1	Dot signal	2.2	----

2.2 Modulation characteristics

2.2.1 Frequency response of audio modulating circuit [FCC § 2.1047(a)]

2.2.1.1 Test procedure

The Radio Equipment JSB-196GM was connected as shown in Fig. 2.2.1.1-1.

An audio oscillator was used to drive the JSB-196GM handset input. The output signal of the MIC amplifier varied from 60Hz to 10kHz was measured with the audio spectrum analyzer.

2.2.1.2 Test results

Test results are shown in Table 2.2.1.2-1 and Fig. 2.2.1.2-1.

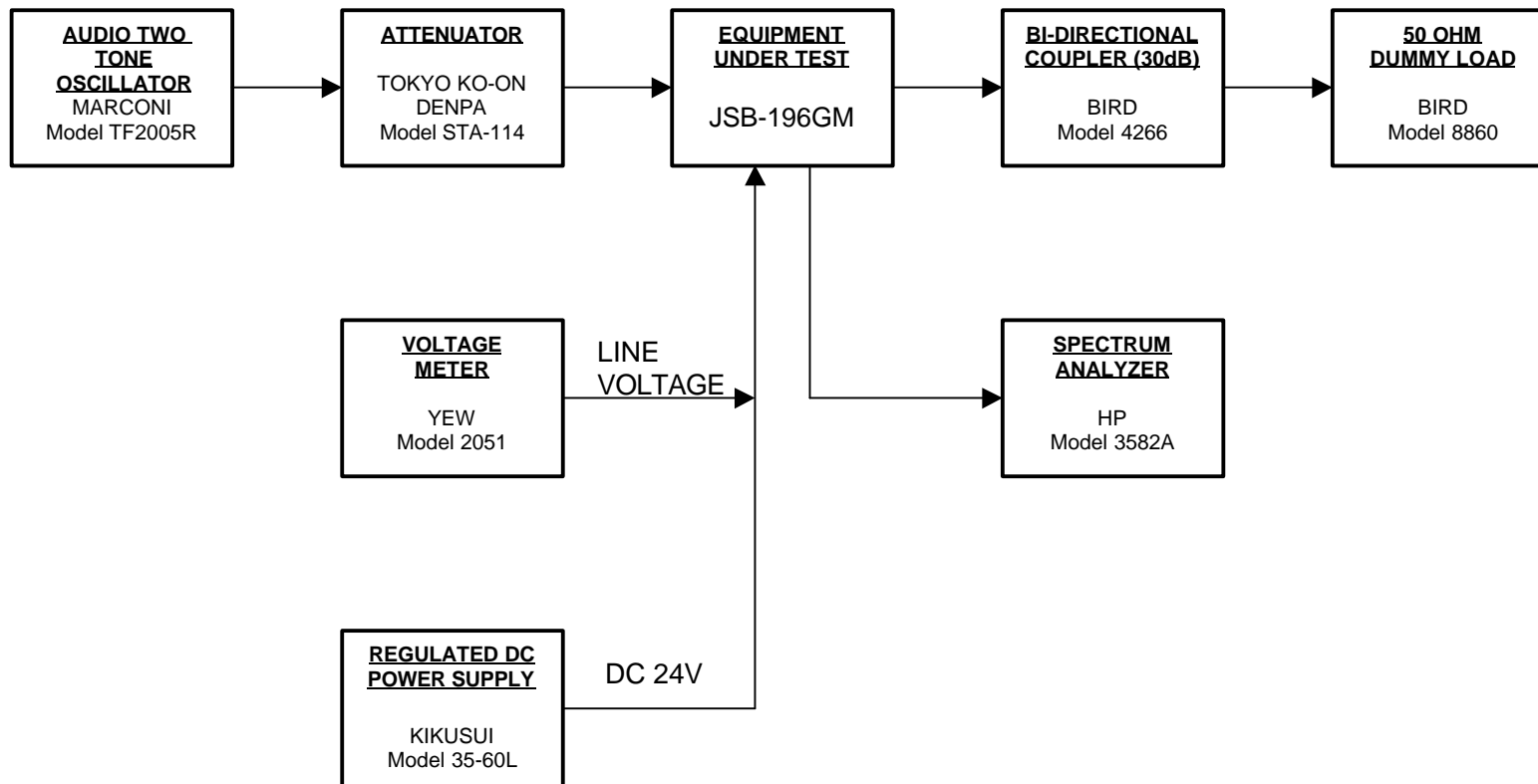
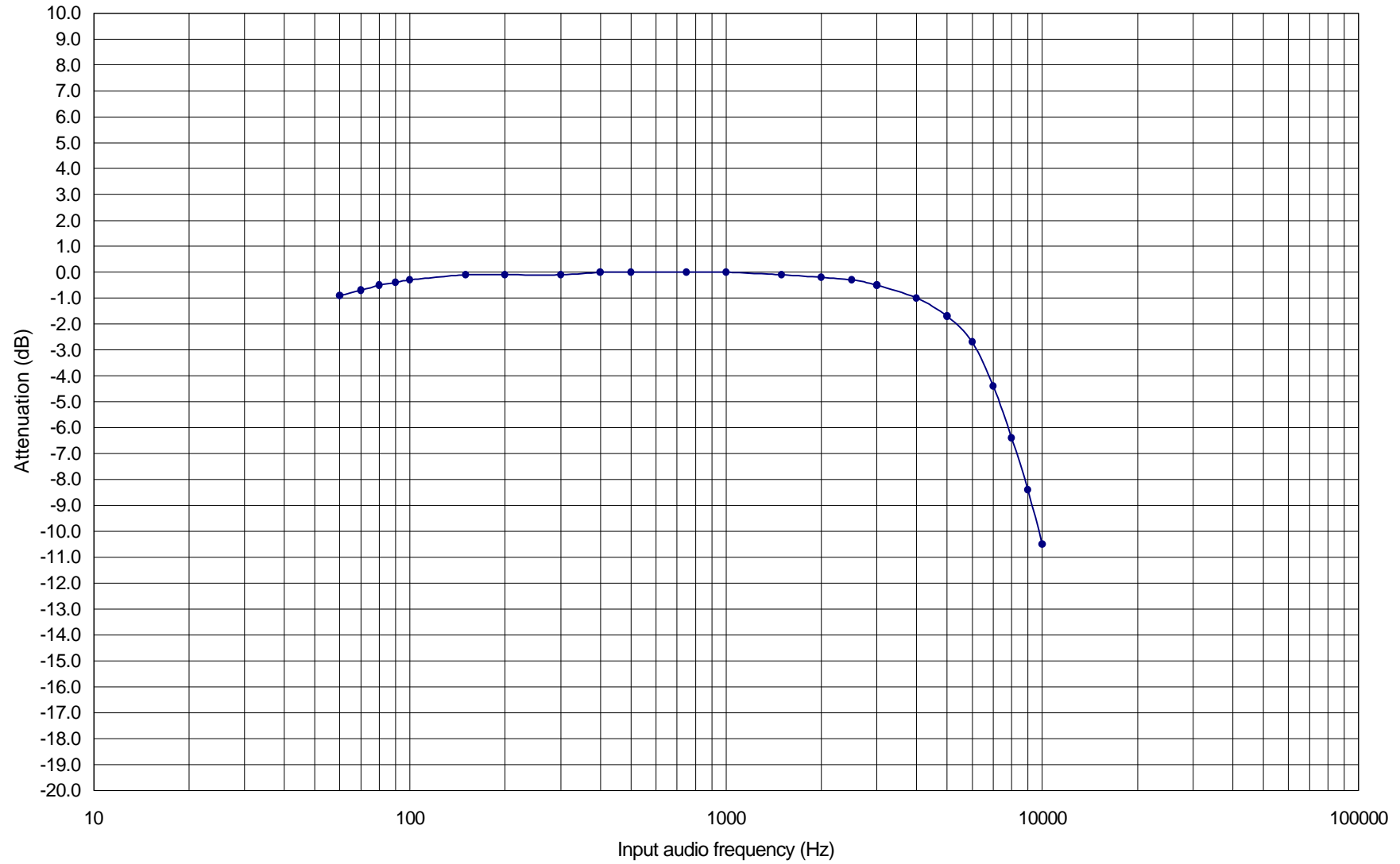

Fig. 2.2.1.1-1 Test set up for Frequency response of audio modulating circuit

Table 2.2.1.2-1 Frequency response of audio modulating circuit

Input Audio oscillator frequency (Hz)	Attenuation (dB)
60	-0.9
70	-0.7
80	-0.5
90	-0.4
100	-0.3
150	-0.1
200	-0.1
300	-0.1
400	0.0
500	0.0
750	0.0
1000	0.0
1500	-0.1
2000	-0.2
2500	-0.3
3000	-0.5
4000	-1.0
5000	-1.7
6000	-2.7
7000	-4.4
8000	-6.4
9000	-8.4
10000	-10.5

Fig. 2.2.1.2-1 Frequency response of audio modulating circuit



2.2.2 Modulation limiting characteristics [FCC § 2.1047(b), § 80.213(a)(3)]

2.2.2.1 Test procedure

The Radio Equipment JSB-196GM was connected as shown in Fig. 2.2.2.1-1.

The modulation in J3E mode was signals of 400Hz and 1800Hz adjusted to produce equal output power.

The audio output voltage was measured with the oscilloscope, and the RF output power was measured with the oscilloscope.

2.2.2.2 Test results

Test results is shown in Table 2.2.2.2-1 and Fig. 2.2.2.2-1.

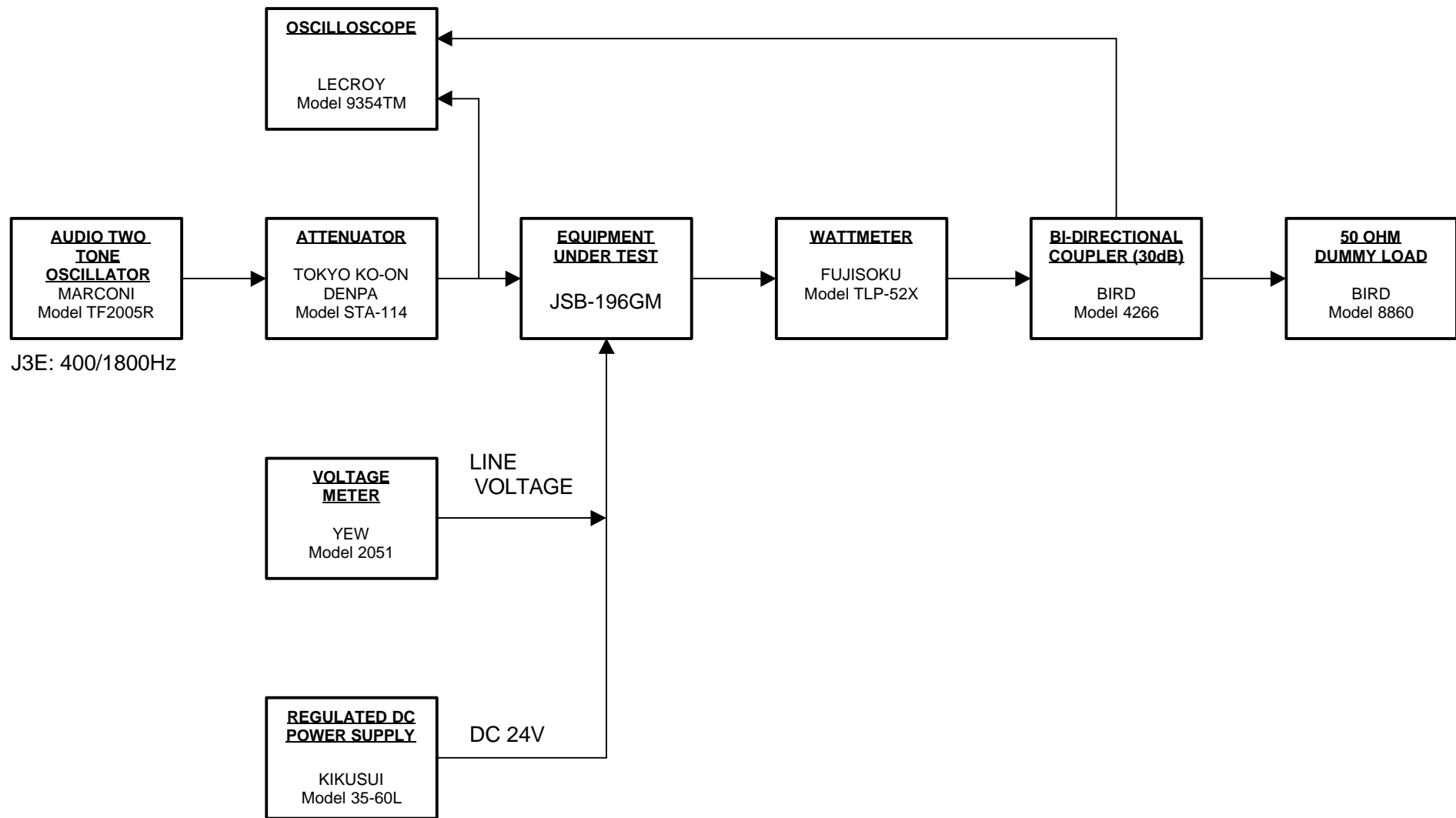

Fig. 2.2.2.1-1 Test set up for Modulation limiting characteristics

Table 2.2.2.2-1 Modulation limiting characteristics

Test frequency: 4112.6kHz

Mode: J3E

Line voltage: DC 24V

Input level (mVrms)	RF output power (Wpep)
0.6	1.2
0.7	2.4
0.8	4
0.9	6.5
1.0	10
1.1	15
1.2	21
1.3	28
1.4	35
1.5	44
1.6	54
1.7	66
1.8	78
1.9	91
2.0	103
2.5	130
3.0	137
4.0	143
5.0	145
6.0	145
7.0	145
8.0	145
9.0	145
10.0	145
11.0	145
12.0	145
13.0	145
14.0	145
15.0	145
16.0	145
17.0	145
18.0	145
19.0	145
20.0	145

Fig. 2.2.2.2-1 Modulation limiting characteristics

Test frequency: 4112.6kHz

Mode: J3E

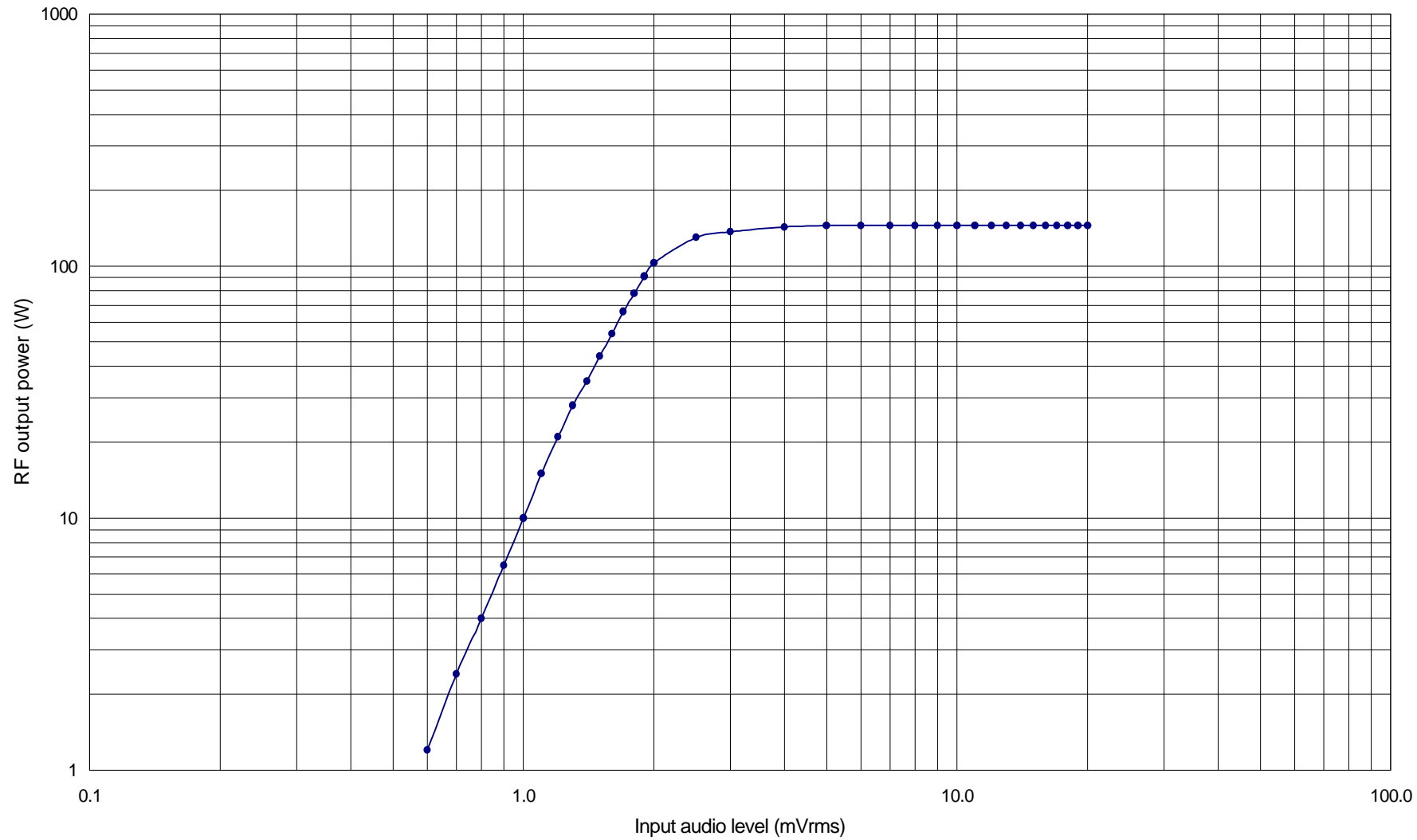

2.2.3 Overall transmitter audio frequency response [FCC § 2.1047(c), 80.211(a)]

2.2.3.1 Test procedure

The Radio Equipment JSB-196GM was connected as shown in Fig. 2.2.3.1-1.

The overall transmitter audio response curve includes the audio response of the complete transmitter from handset input to power output. The level of test signal varied from 50Hz to 10kHz adjusted so that the output power at the peak response characteristic was 10dB below the rated output power. The peak response was measured with the spectrum analyzer.

2.2.3.2 Test results

Test results are shown in Table 2.2.3.2-1 and Fig. 2.2.3.2-1.

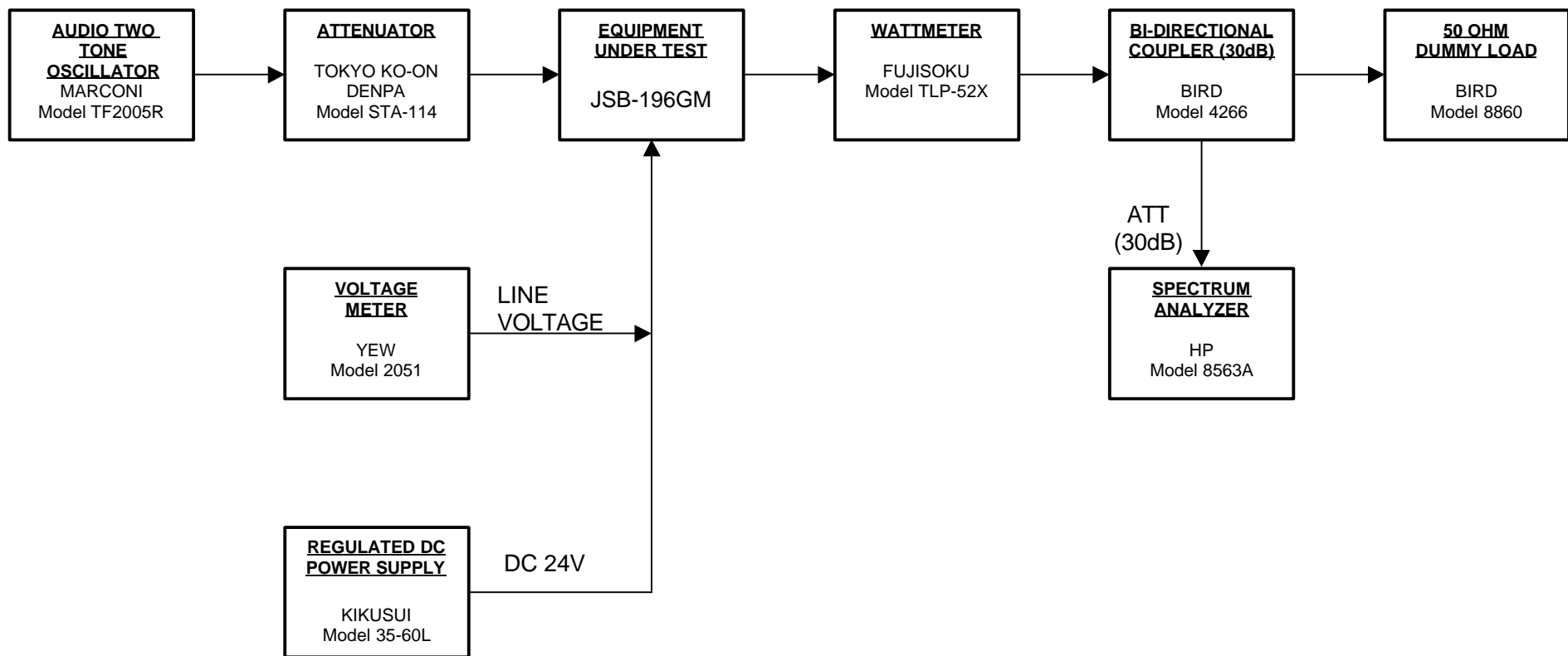

Fig. 2.2.3.1-1 Test set up for Overall transmitter audio frequency response

Table 2.2.3.2-1 Overall transmitter audio frequency response

Input Audio oscillator frequency (Hz)	Attenuation (dB)
50	-90.0
60	-90.0
70	-90.0
80	-90.0
90	-90.0
100	-90.0
120	-89.0
140	-87.0
160	-80.0
180	-66.2
200	-55.2
250	-28.7
300	-4.0
400	0.0
500	-0.2
600	0.0
700	0.0
800	-0.2
900	-0.3
1000	-0.2
1500	-0.8
2000	-1.7
2500	-3.2
2600	-3.4
2700	-4.5
2750	-8.5
2800	-36.2
2900	-74.2
3000	-80.0
3500	-87.0
4000	-89.0
5000	-90.0
7000	-90.0
10000	-90.0

2.3 Occupied bandwidth
[FCC § 2.1049(a),(c)(2), § 80.205(a), § 80.211(a),(f)]

2.3.1 Test procedure

The Radio Equipment JSB-196GM was connected as shown in Fig. 2.3.1-1.

The transmitter was modulated with signals of 400Hz and 1800Hz for J3E mode, with 16 dots per second for A1A mode, with continuous dot pattern for F1B mode.

The J3E modulation level was shown in Fig. 2.2.2.2-1 of the Modulation limiting characteristics. The J3E audio input level was constant at 10dB over the rated output power as per § 2.1047(c). The spectrum analyzer was adjusted so that mean power was at the 0dB reference.

The equipment was tested on each of marine bands in the transmitter frequency range with J3E, A1A and F1B modes, on the 2MHz marine band at two frequencies with J3E, A1A and F1B modes.

2.3.2 Test results

Test results are shown from Fig. 2.3.2-1 to Fig. 2.3.2-36.

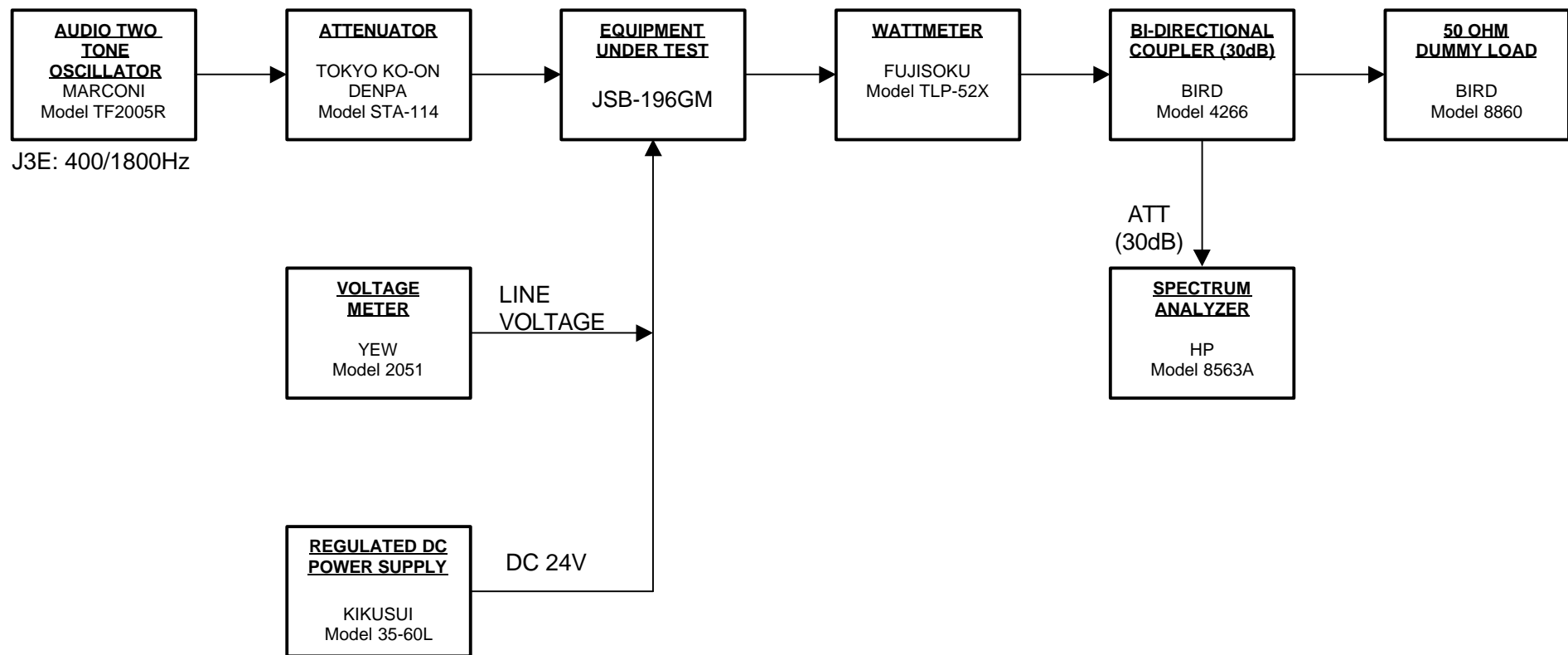

Fig. 2.3.1-1 Test set up for Occupied bandwidth

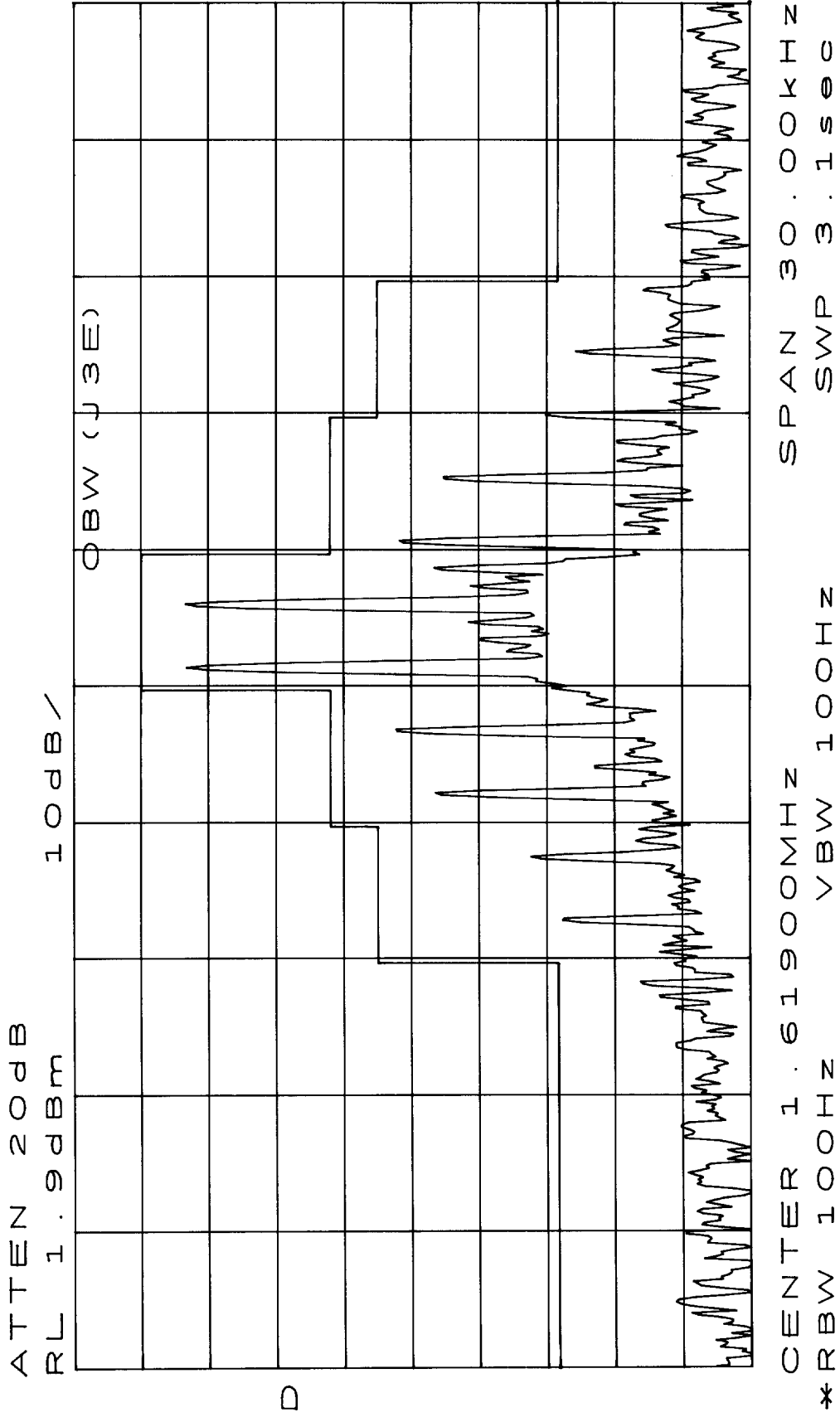
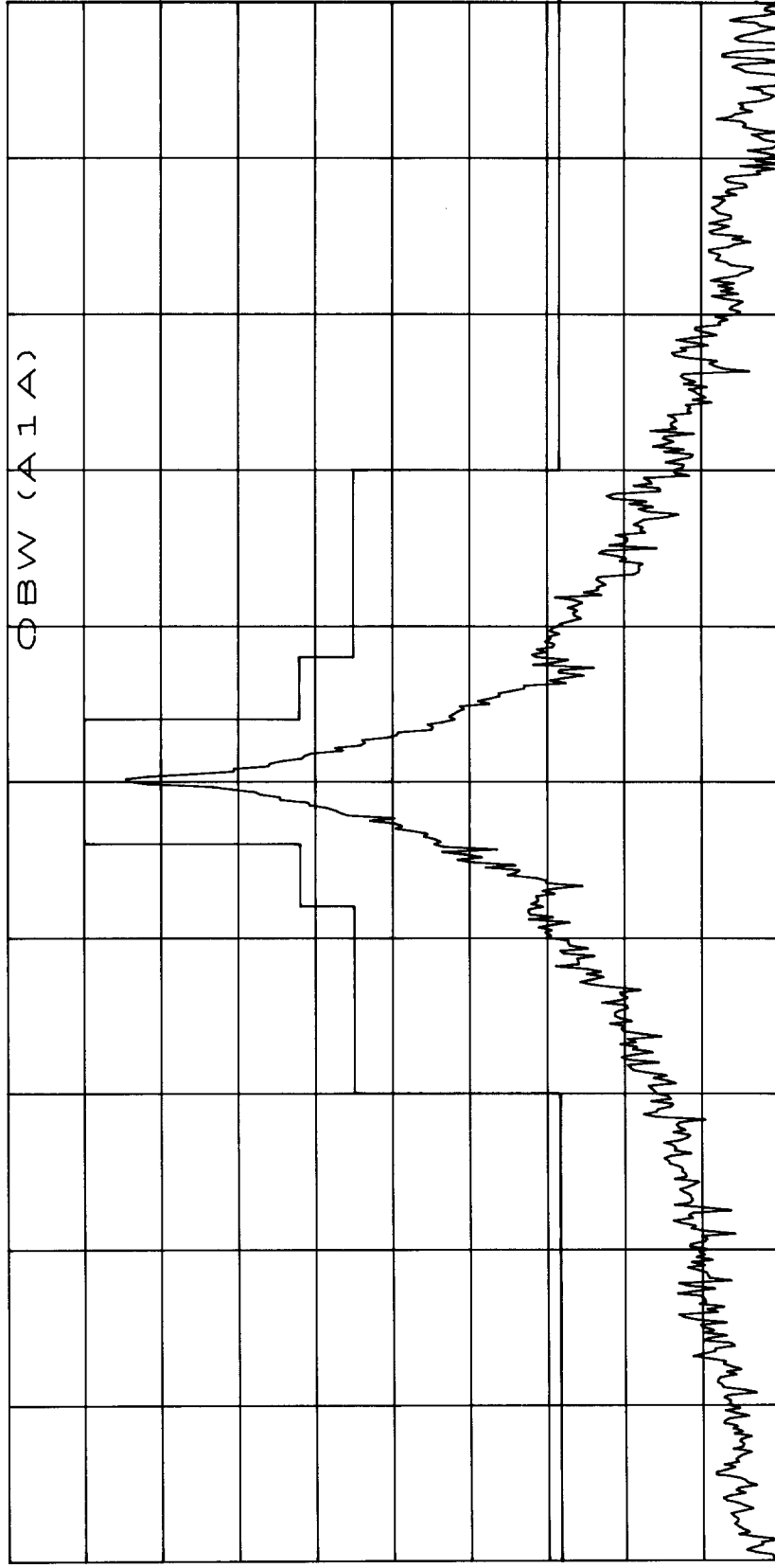

Fig. 2.3.2-1 Occupied bandwidth

Frequency: 1619.0kHz
 Mode: J3E
 Line Voltage: DC 24V

ATTEN 20dB
RL 1.9dBm

10dB/



CENTER 1.619000MHZ SPAN 5.000KHZ
*RBW 10HZ VBW 10HZ *SWP 10sec

Fig. 2.3.2-2 Occupied bandwidth

Frequency: 1619.0kHz
Mode: A1A
Line Voltage: DC 24V

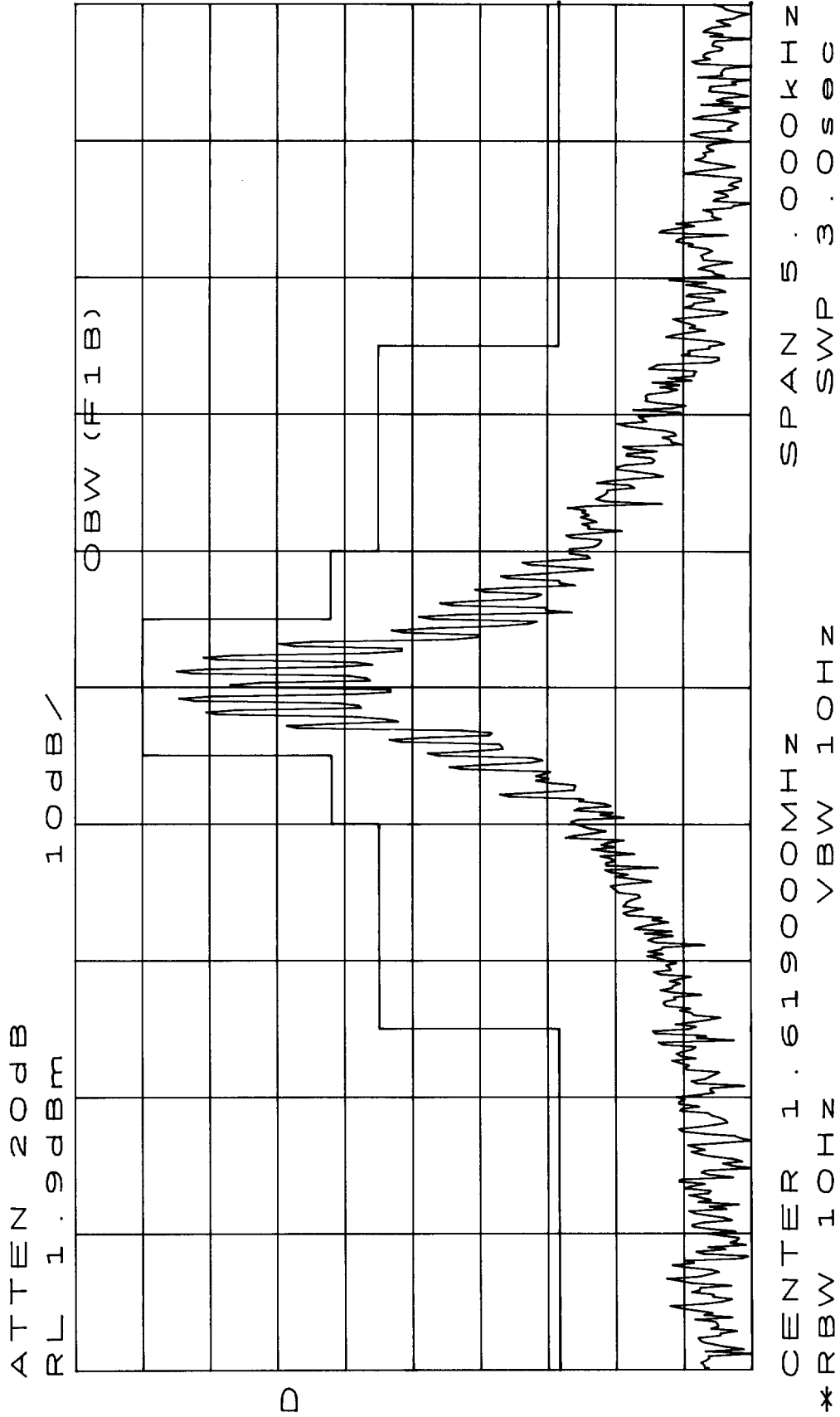

Fig. 2.3.2-3 Occupied bandwidth

Frequency: 1619.0kHz
 Mode: F1B
 Line Voltage: DC 24V

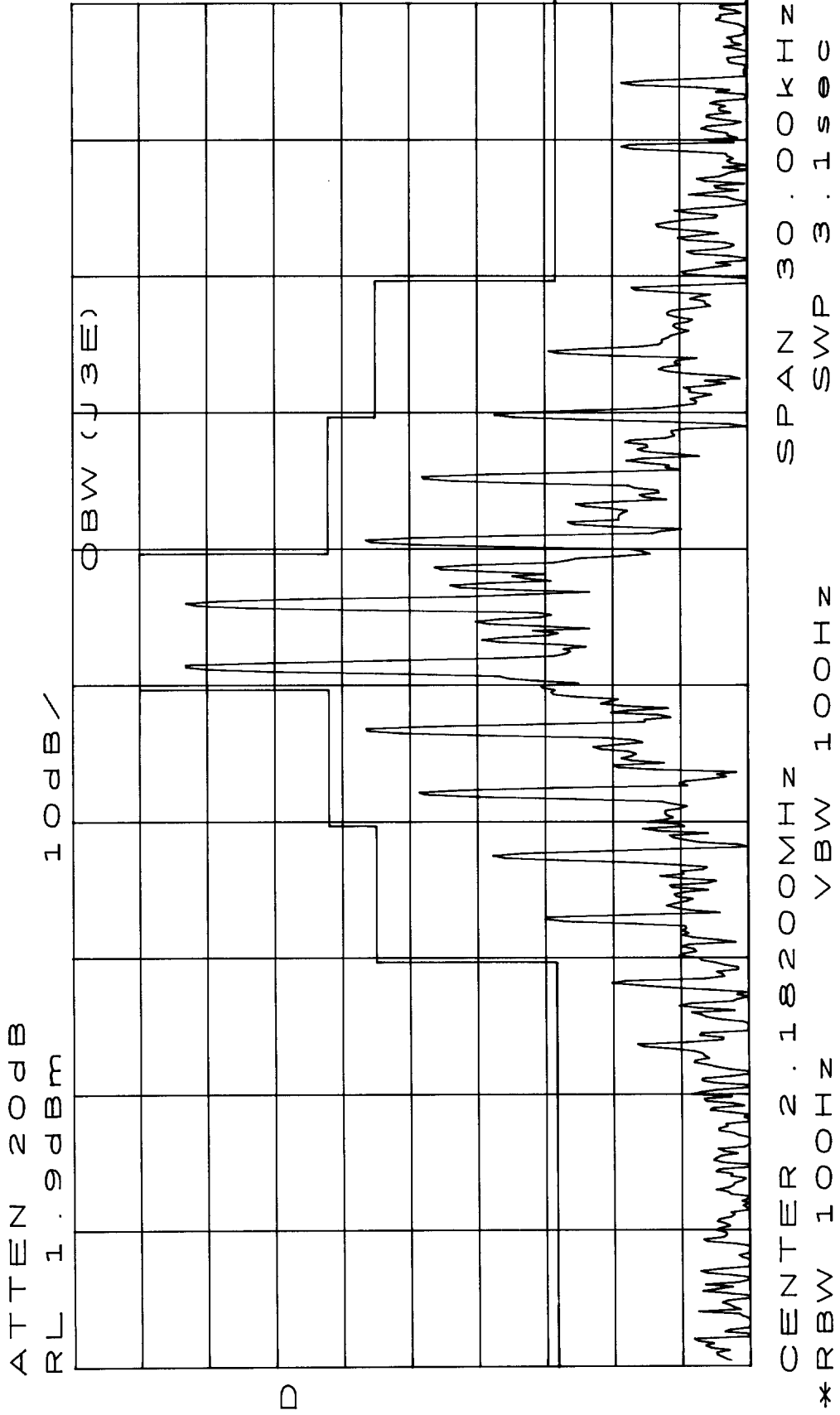
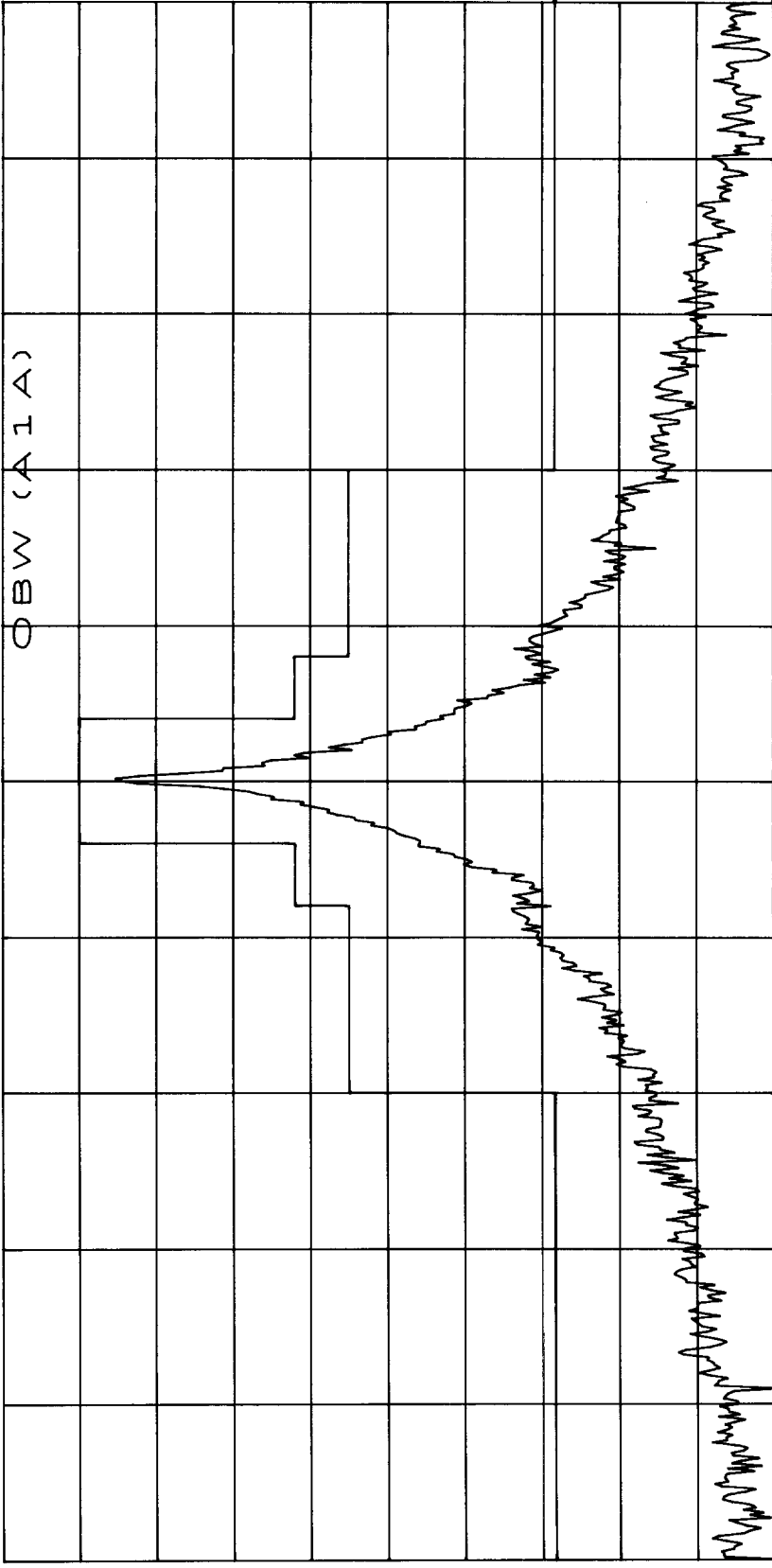

Fig. 2.3.2-4 Occupied bandwidth

Frequency: 2182.0kHz
 Mode: J3E
 Line Voltage: DC 24V

ATTEN 20dB
RL 1.9dBm

10dB/



D

CENTER 2.18200MHZ
*RBW 10HZ
SPAN 5.000KHZ
*SWP 10SEC
VBW 10HZ

Fig. 2.3.2-5 Occupied bandwidth

Frequency: 2182.0kHz
Mode: A1A
Line Voltage: DC 24V

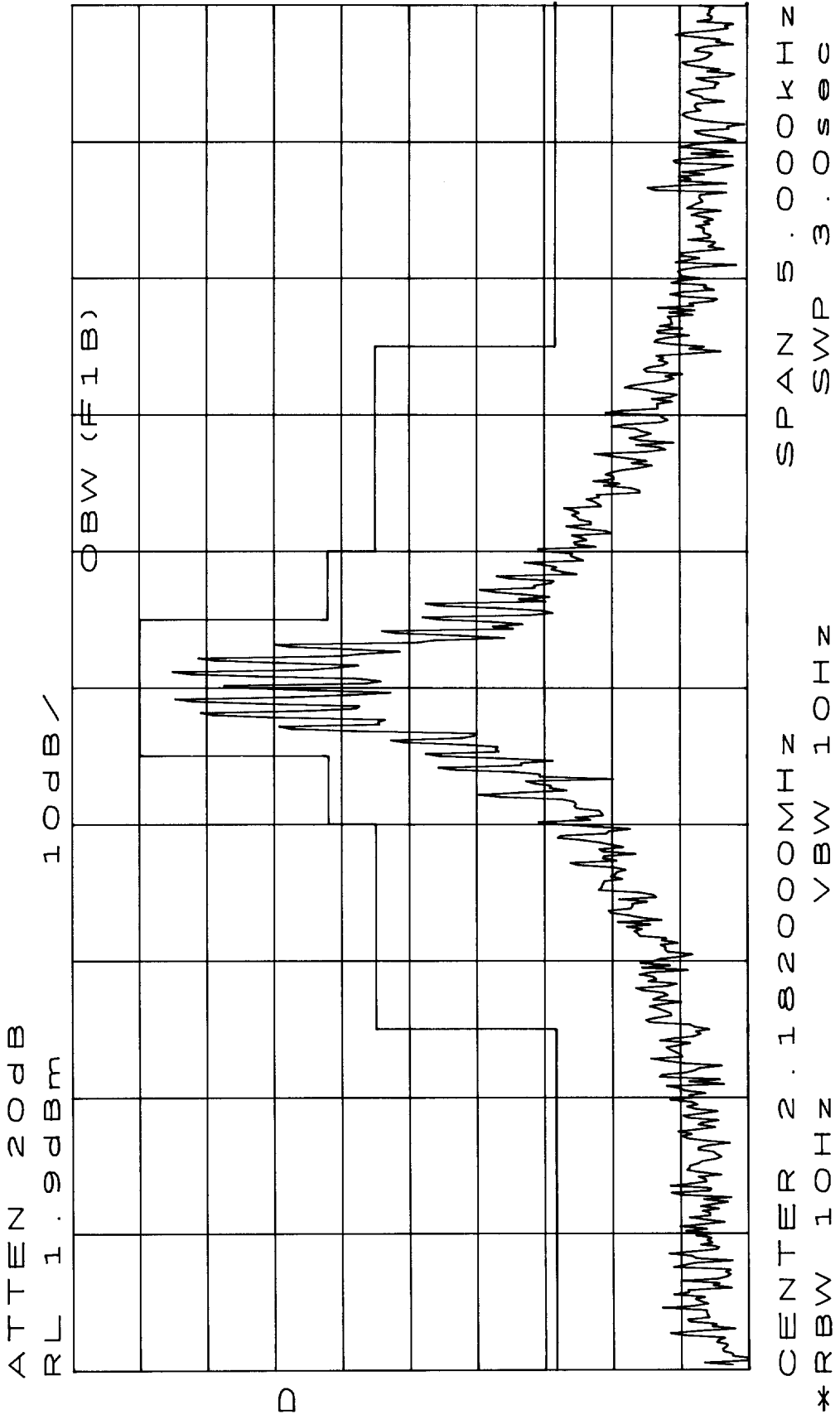
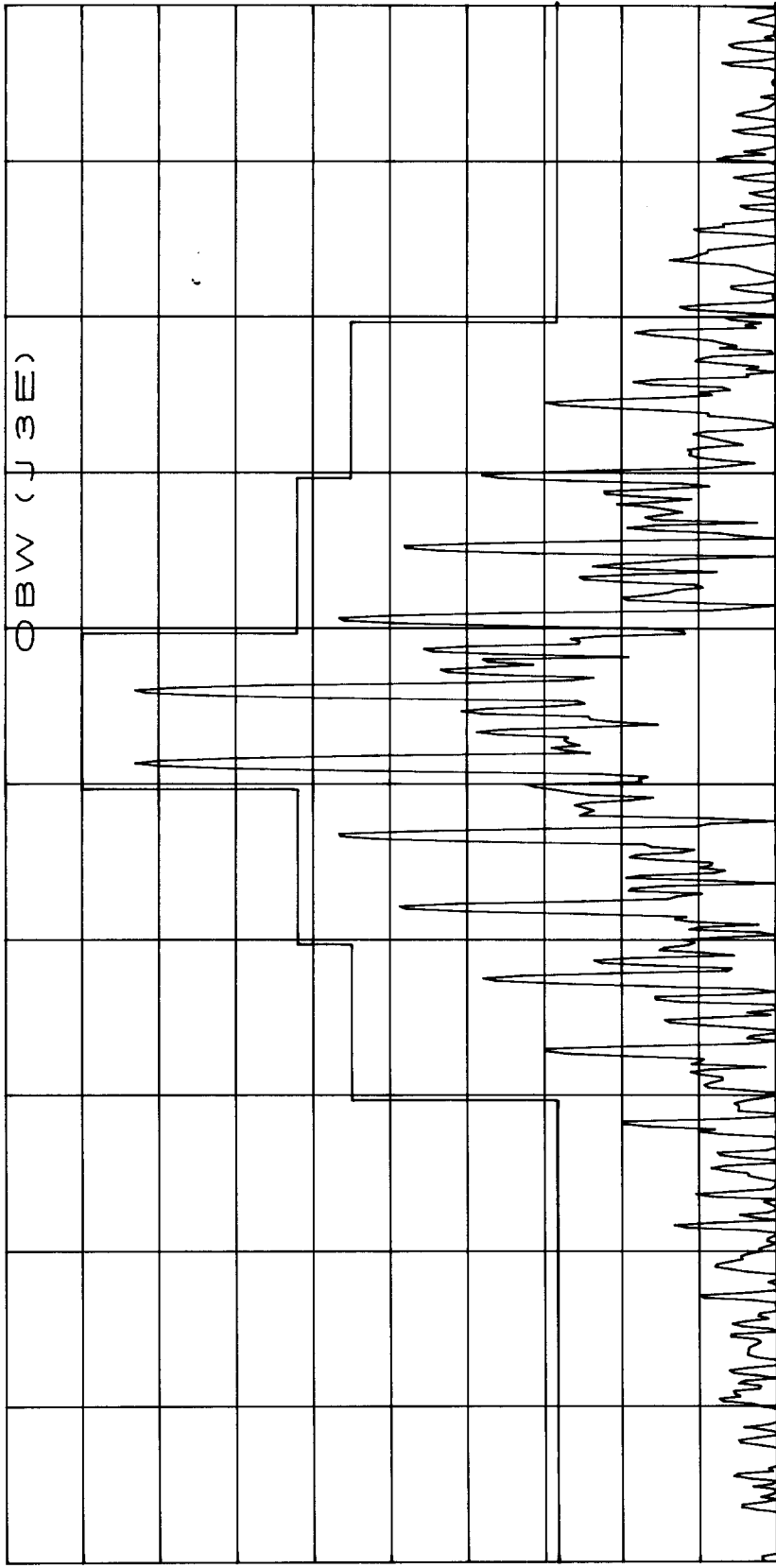

Fig. 2.3.2-6 Occupied bandwidth

Frequency: 2182.0kHz
 Mode: F1B
 Line Voltage: DC 24V

ATTEN 20dB
RL 1.9dBm

10dB/



D

CENTER 2.18750MHZ SPAN 30.00KHZ
*RBW 100HZ VBW 100HZ SWP 3.1sec

Fig. 2.3.2-7 Occupied bandwidth

Frequency: 2187.5kHz
Mode: J3E
Line Voltage: DC 24V

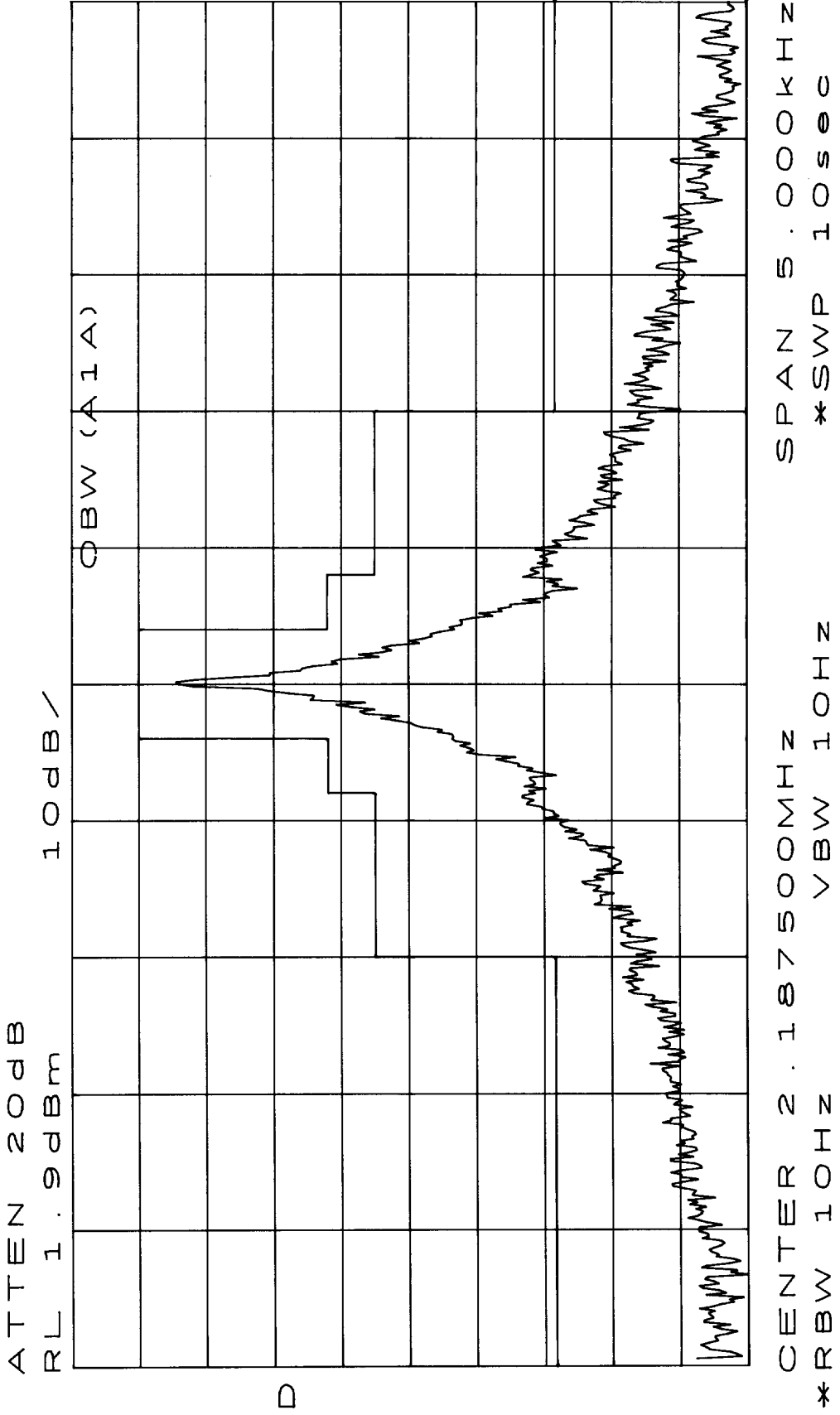
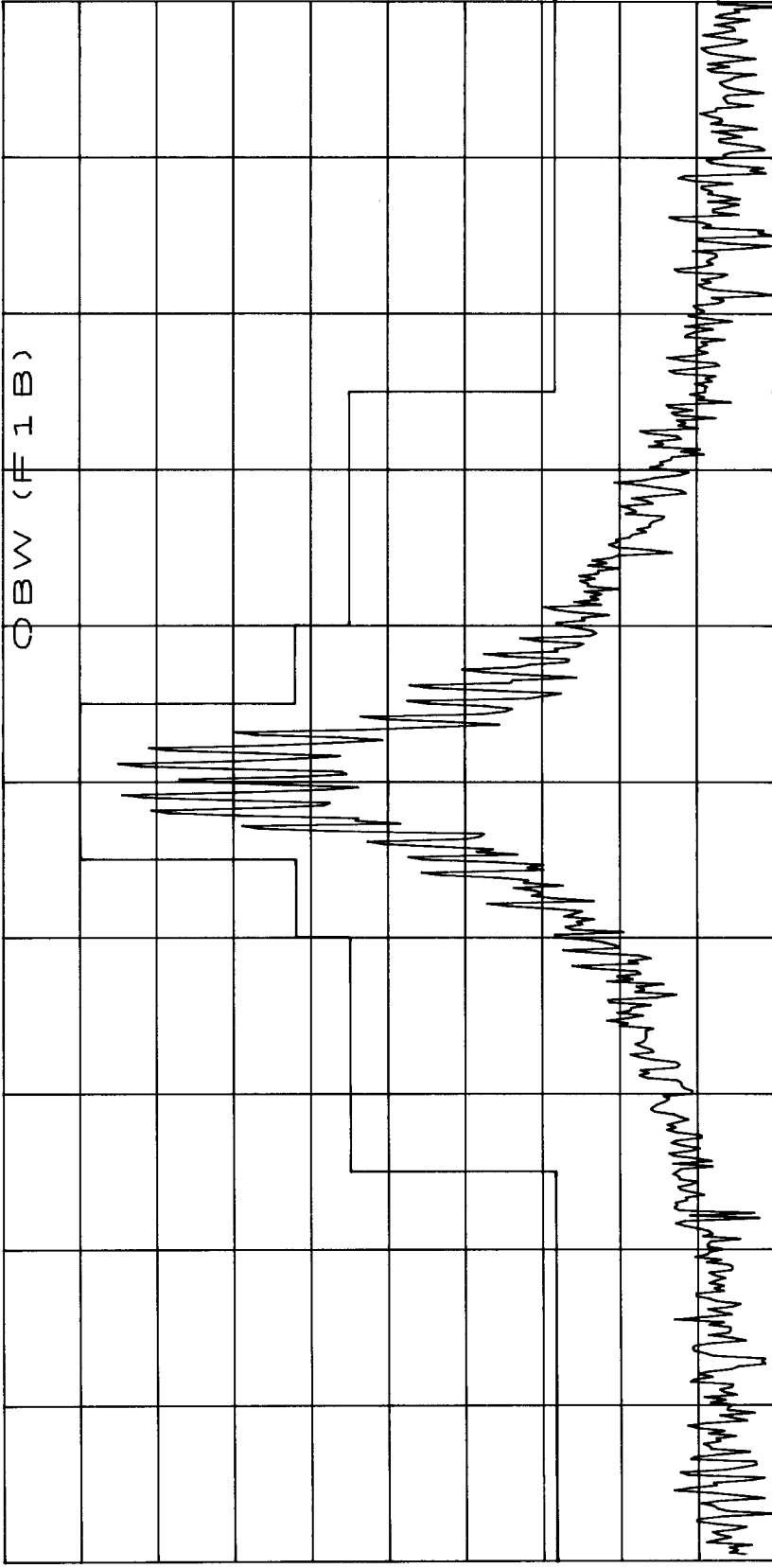

Fig. 2.3.2-8 Occupied bandwidth

Frequency: 2187.5kHz
 Mode: A1A
 Line Voltage: DC 24V

ATTEN 20dB
RL 1.9dBm

10dB/



OBW (F1B)

CENTER 2.187500MHZ
*RBW 10HZ
SPAN 5.000KHZ
VBW 10HZ
SWP 3.0sec

Fig. 2.3.2-9 Occupied bandwidth

Frequency: 2187.5kHz
Mode: F1B
Line Voltage: DC 24V

ATTEN 20dB
RL 1.9dBm

10dB/

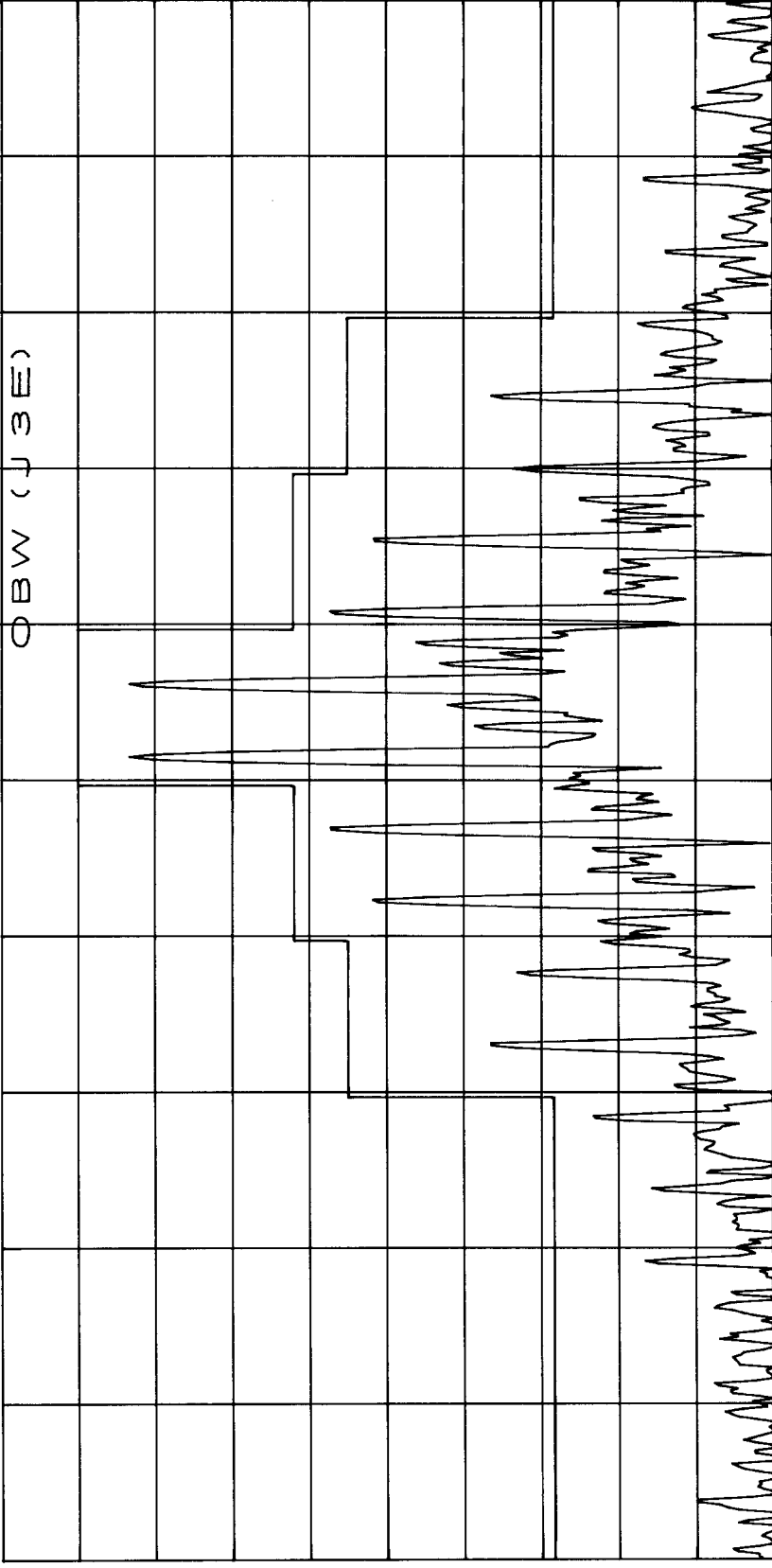

D

CENTER 2.83000MHZ SPAN 30.00KHZ
*RBW 100HZ VBW 100HZ SWP 3.1sec

Fig. 2.3.2-10 Occupied bandwidth

Frequency: 2830.0kHz
Mode: J3E
Line Voltage: DC 24V

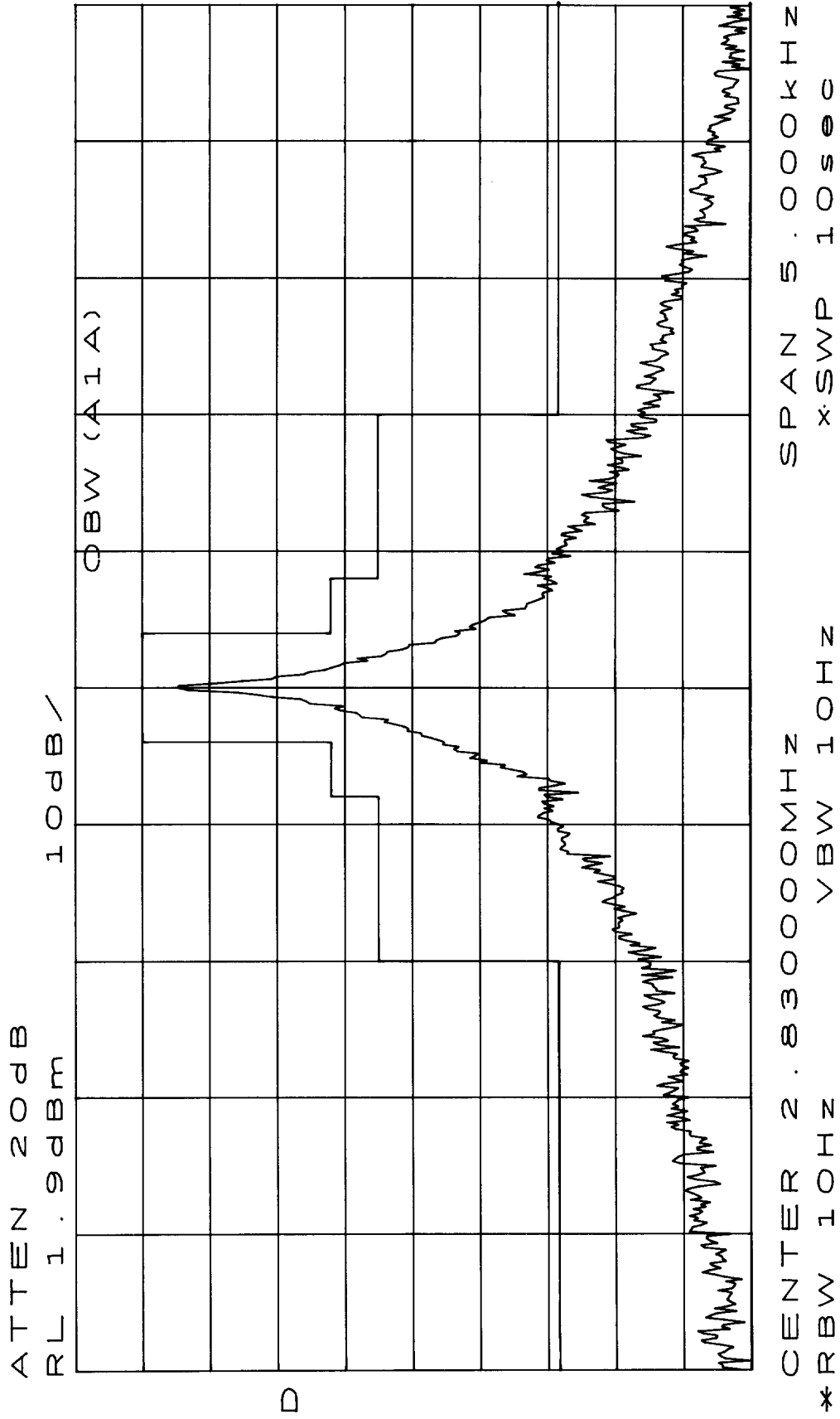

Fig. 2.3.2-11 Occupied bandwidth

Frequency: 2830.0kHz
 Mode: A1A
 Line Voltage: DC 24V

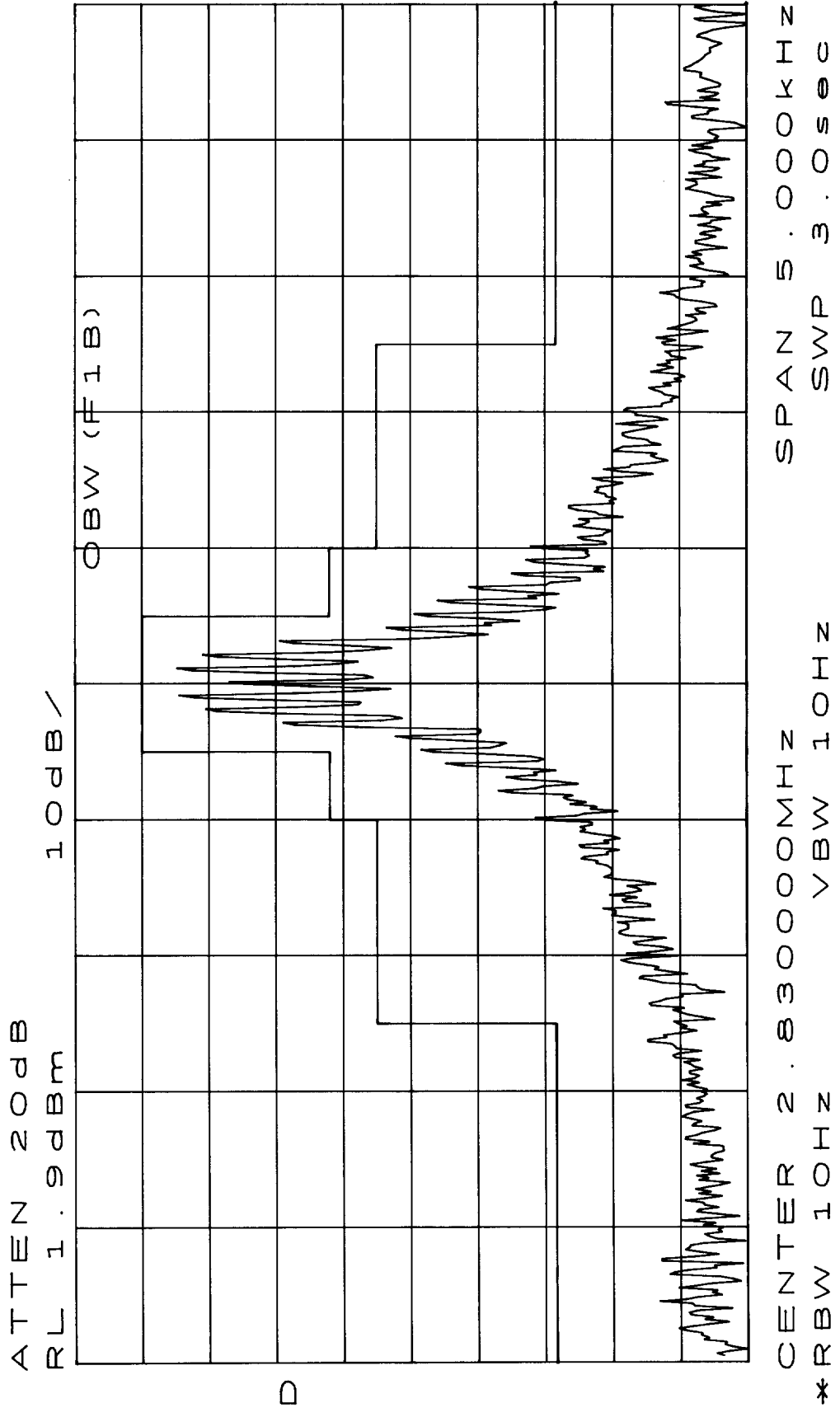
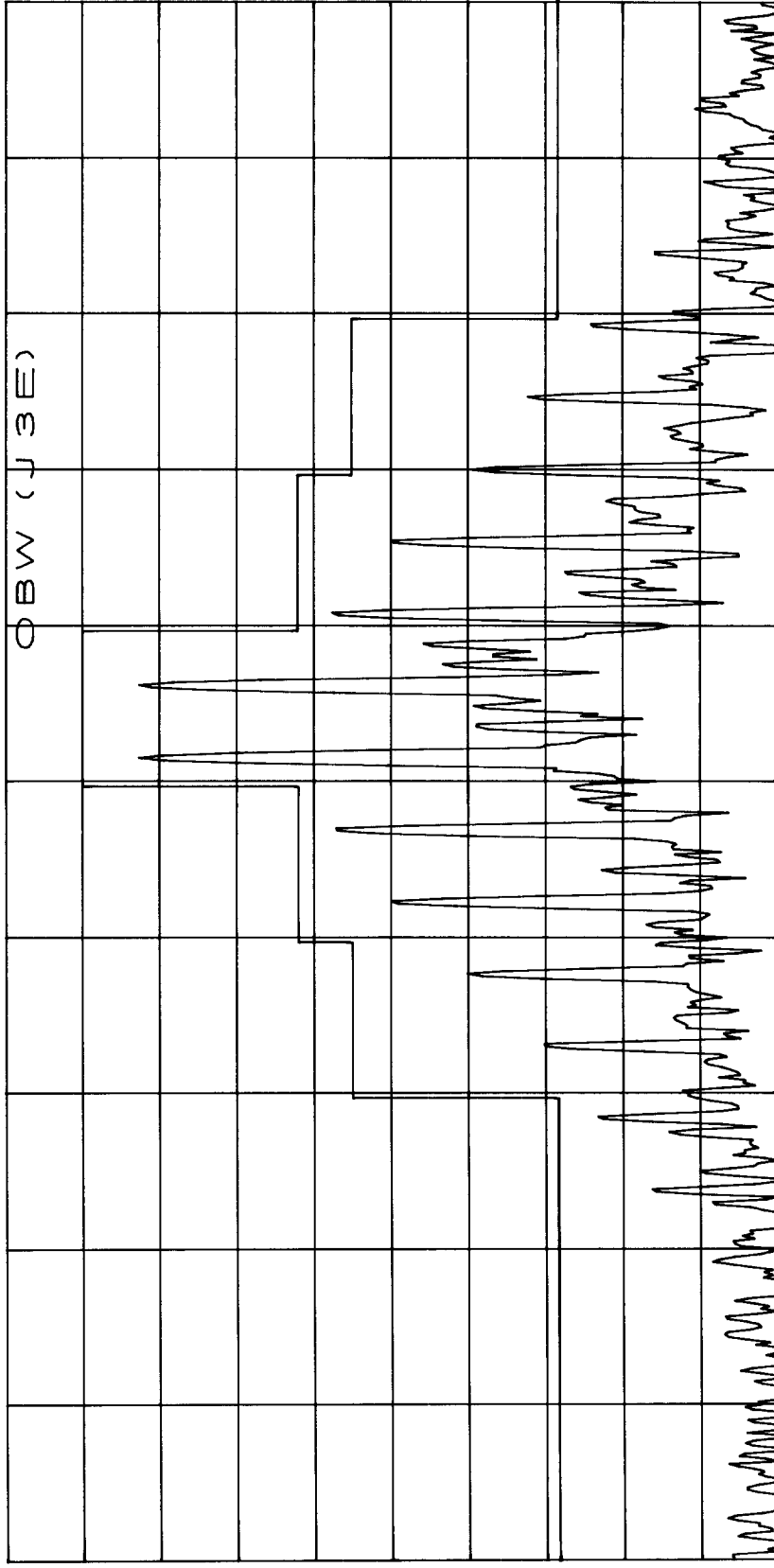

Fig. 2.3.2-12 Occupied bandwidth

Frequency: 2830.0kHz
 Mode: F1B
 Line Voltage: DC 24V

ATTEN 20dB
RL 1.9dBm

10dB/



CENTER 3.25800MHZ VBW 100HZ SPAN 30.00KHZ
*RBW 100HZ SWP 3.1sec

Fig. 2.3.2-13 Occupied bandwidth

Frequency: 3258.0kHz
Mode: J3E
Line Voltage: DC 24V

ATTEN 20dB
RL 1.9dBm

10dB/

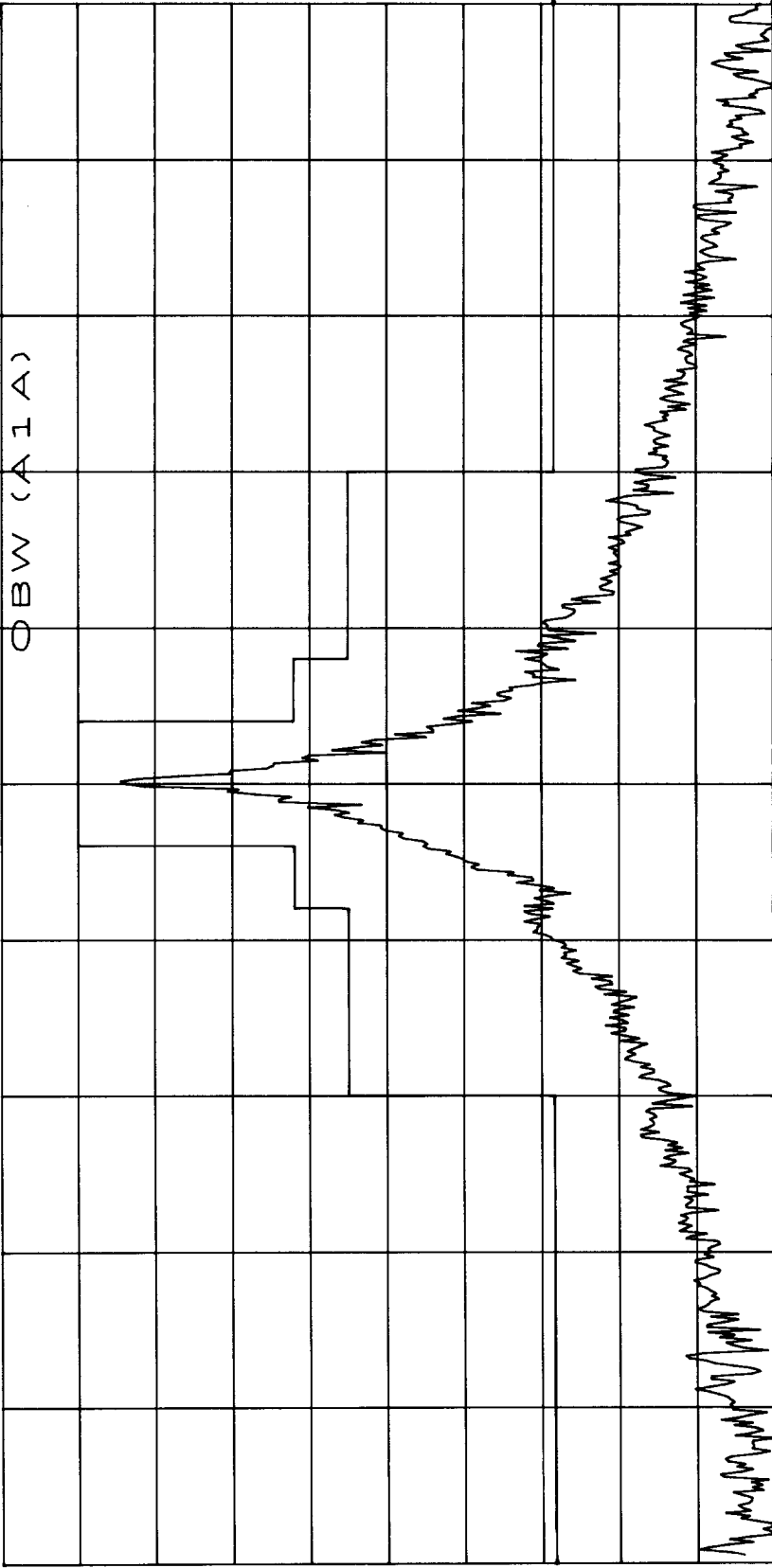

D

CENTER 3.258000MHZ
*RBW 10HZ
SPAN 5.000KHZ
*SWP 10sec
VBW 10HZ

Fig. 2.3.2-14 Occupied bandwidth

Frequency: 3258.0kHz
Mode: A1A
Line Voltage: DC 24V

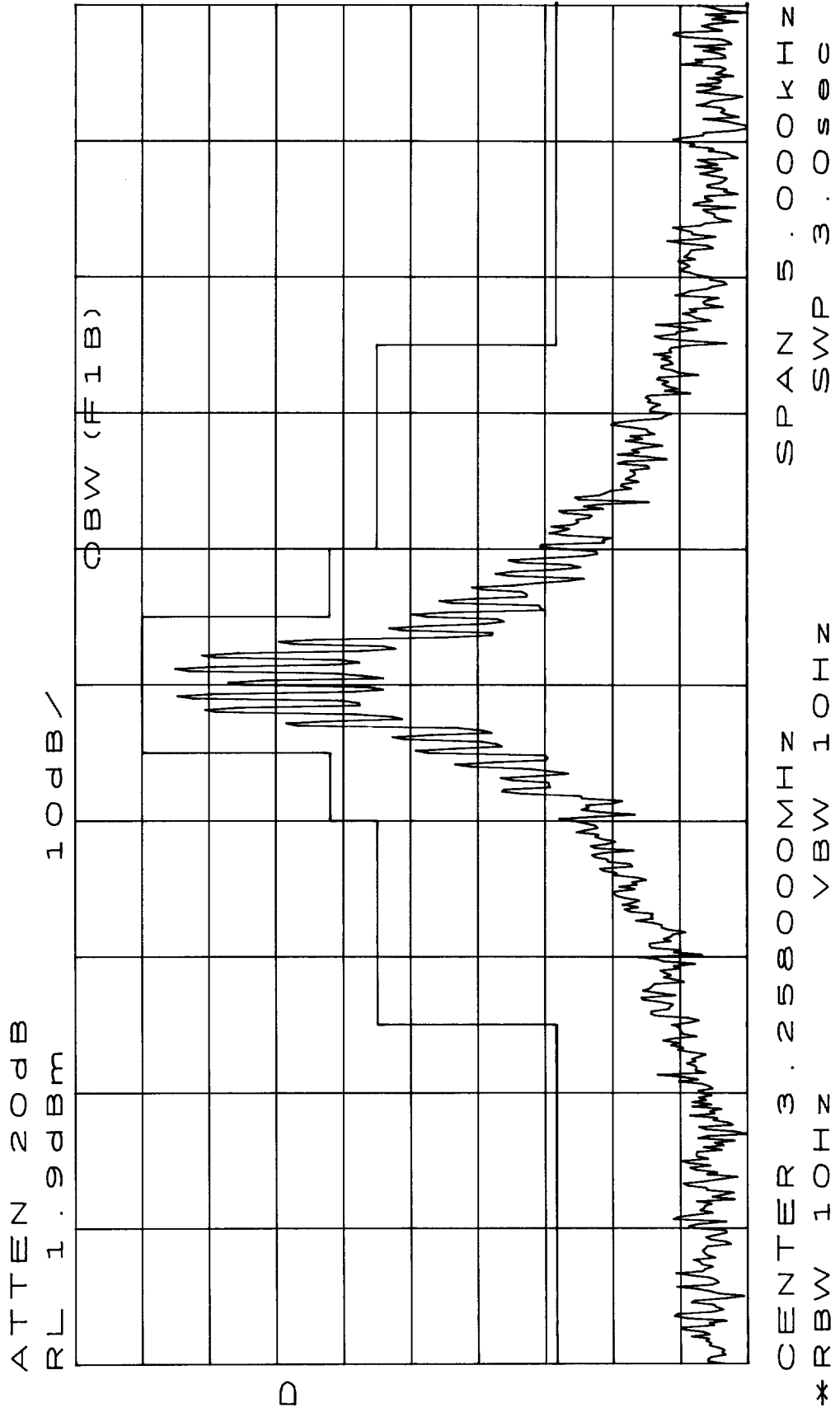
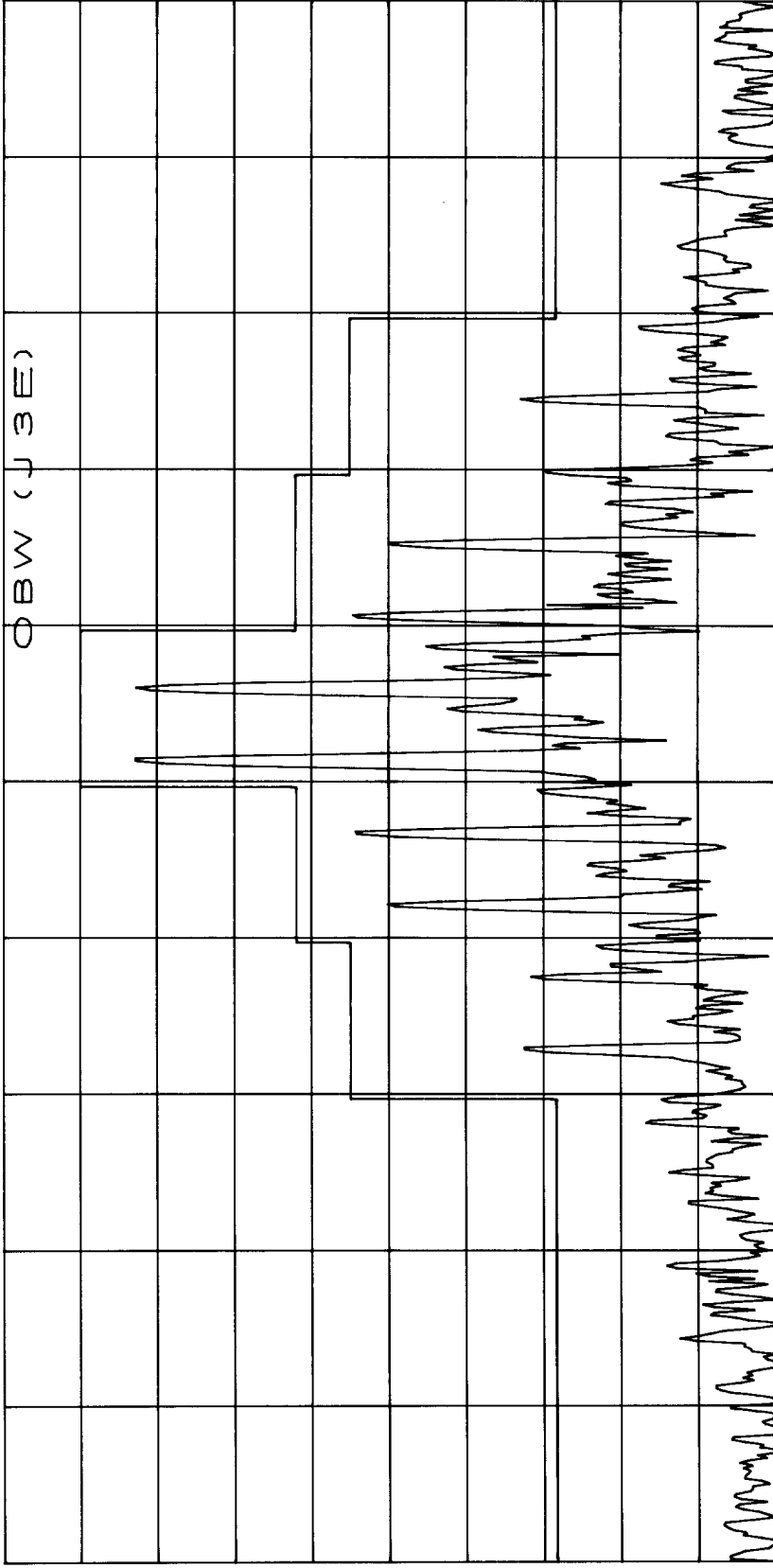

Fig. 2.3.2-15 Occupied bandwidth

Frequency: 3258.0kHz
 Mode: F1B
 Line Voltage: DC 24V

ATTEN 20dB
RL 1.9dBm

10dB/



D

OBW (J3E)

CENTER 4.11200MHZ V BW 100HZ SPAN 30.00KHZ
*RBW 100HZ SWP 3.1sec

Fig. 2.3.2-16 Occupied bandwidth

Frequency: 4112.0kHz
Mode: J3E
Line Voltage: DC 24V

ATTEN 20dB
RL 1.9dBm

10dB/

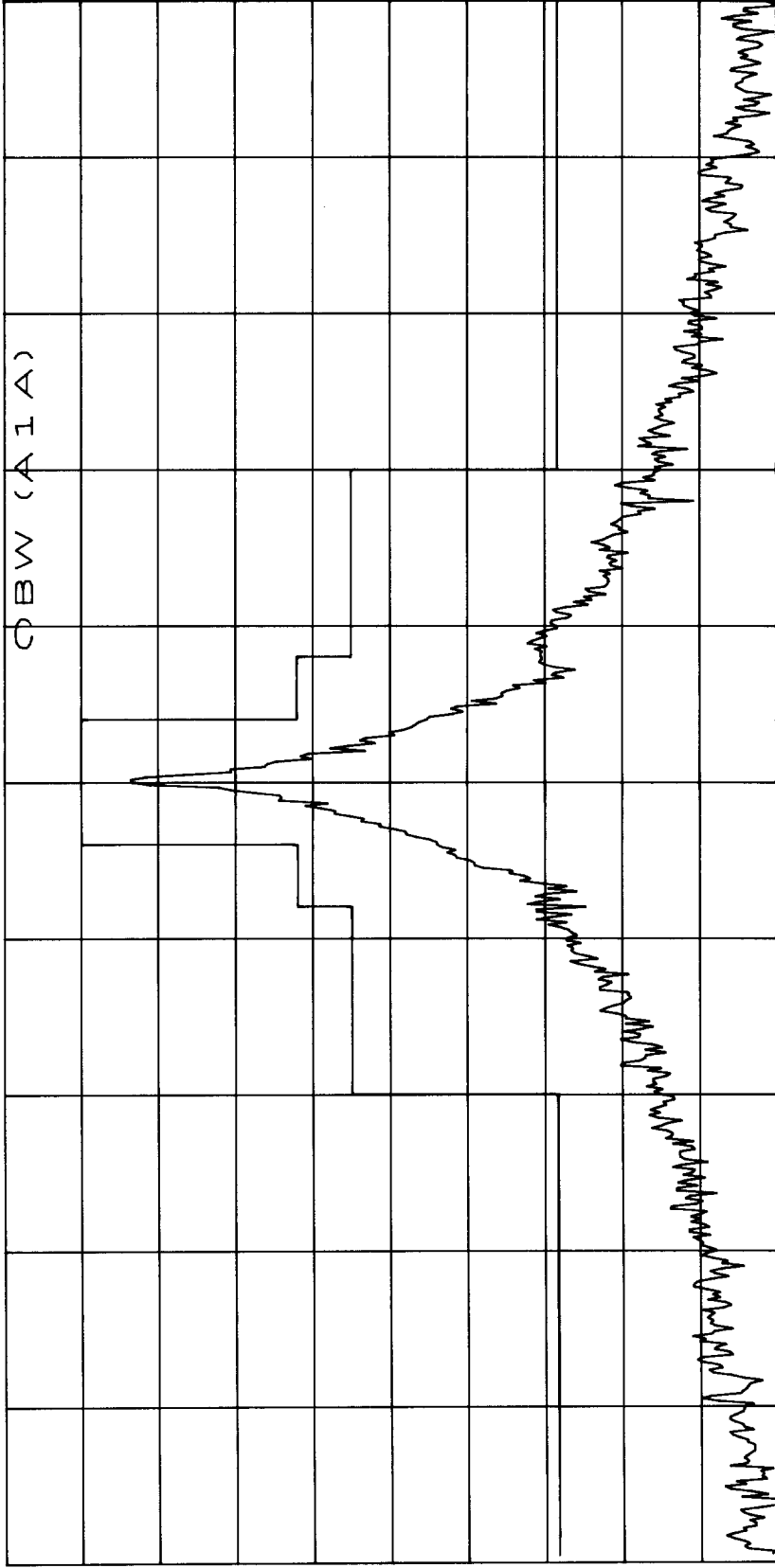

CENTER 4.112000MHZ VBW 10HZ SPAN 5.000KHZ
*RBW 10HZ *SWP 10sec

Fig. 2.3.2-17 Occupied bandwidth

Frequency: 4112.0kHz
Mode: A1A
Line Voltage: DC 24V

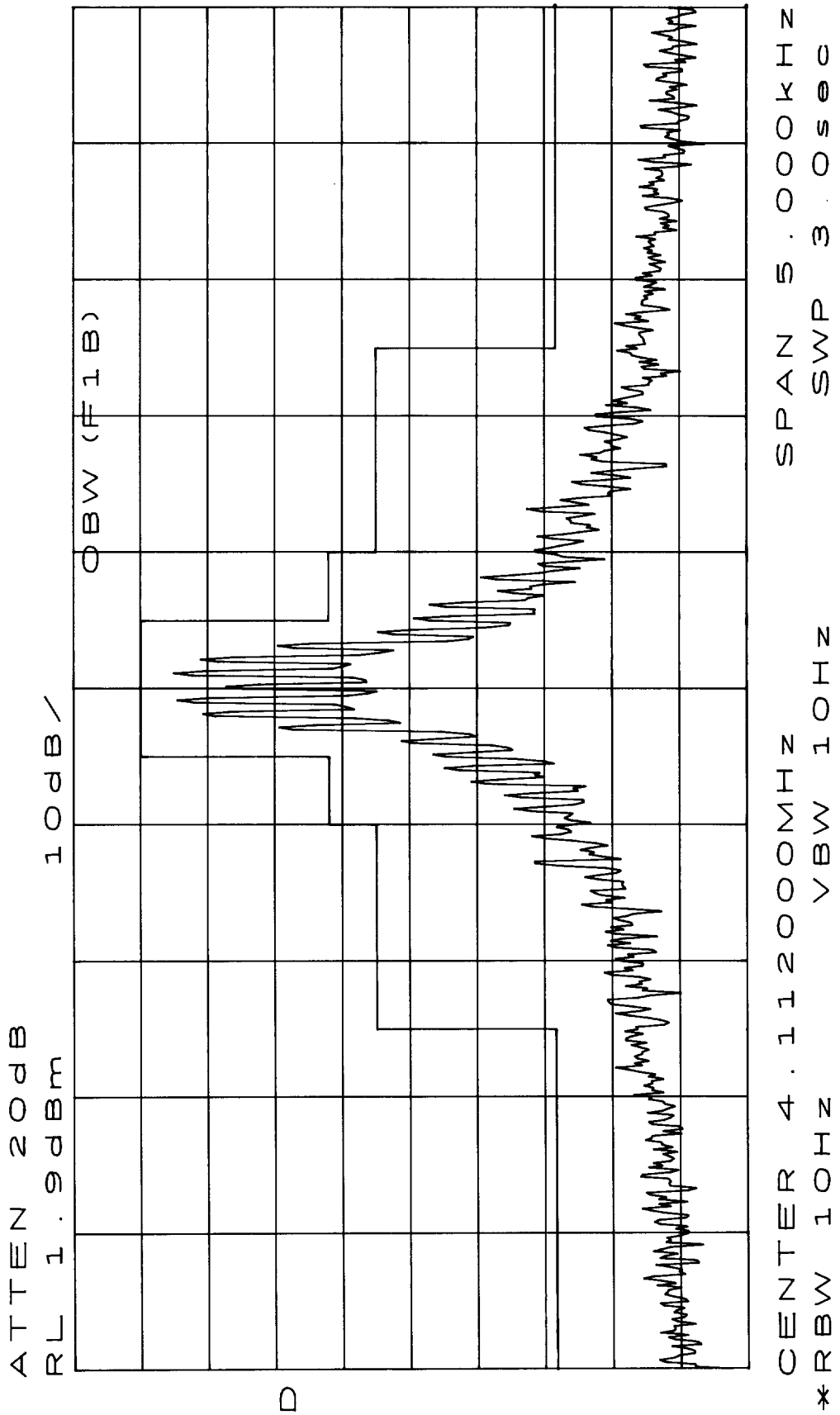
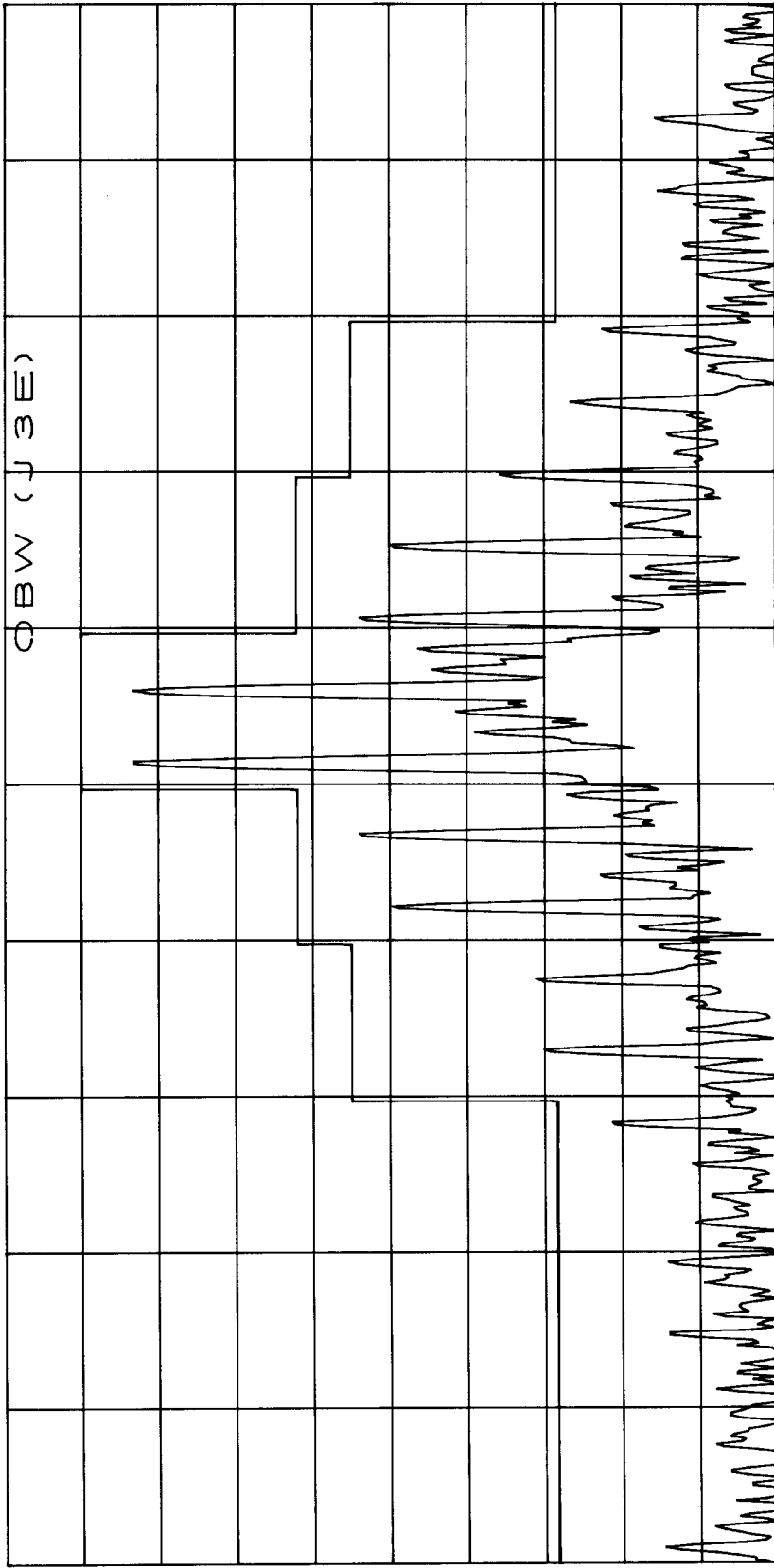

Fig. 2.3.2-18 Occupied bandwidth

Frequency: 4112.0kHz
 Mode: F1B
 Line Voltage: DC 24V

ATTEN 20dB
RL 1.9dBm

10dB/



OBW (J3E)

CENTER 6.21200MHZ VBW 100HZ SPAN 30.00KHZ
*RBW 100HZ SWP 3.1sec

Fig. 2.3.2-19 Occupied bandwidth

Frequency: 6212.0kHz
Mode: J3E
Line Voltage: DC 24V

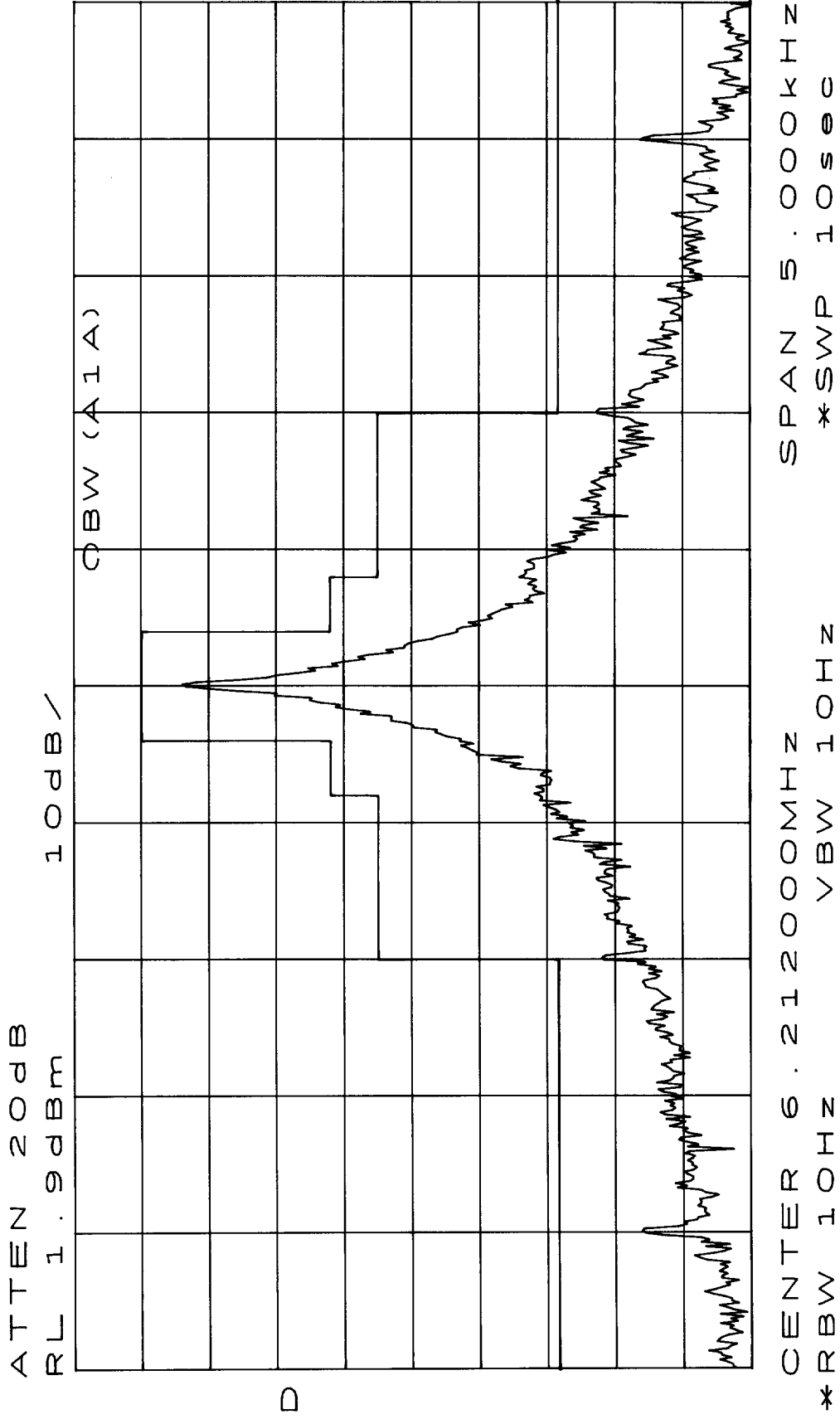

Fig. 2.3.2-20 Occupied bandwidth

Frequency: 6212.0kHz
 Mode: A1A
 Line Voltage: DC 24V

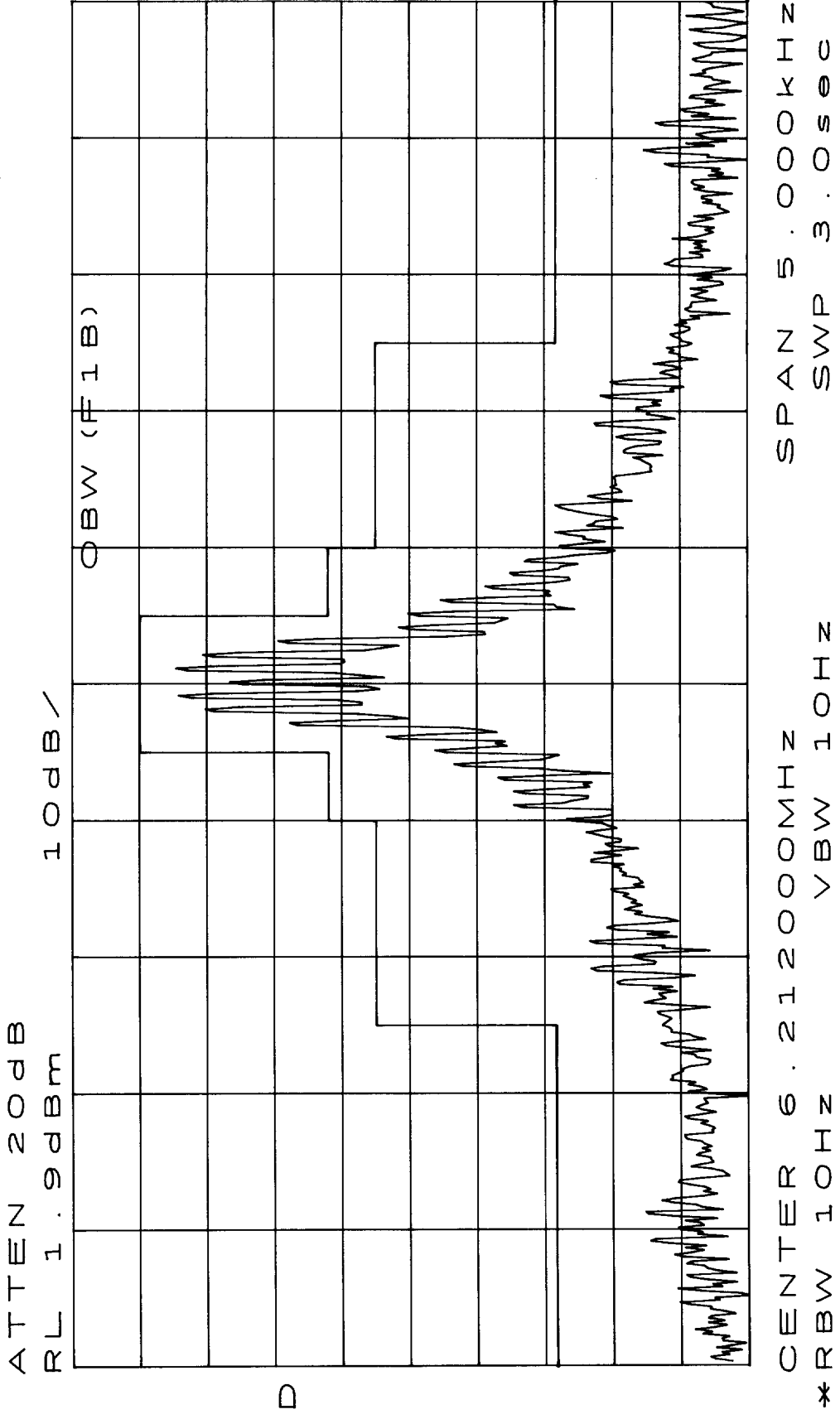
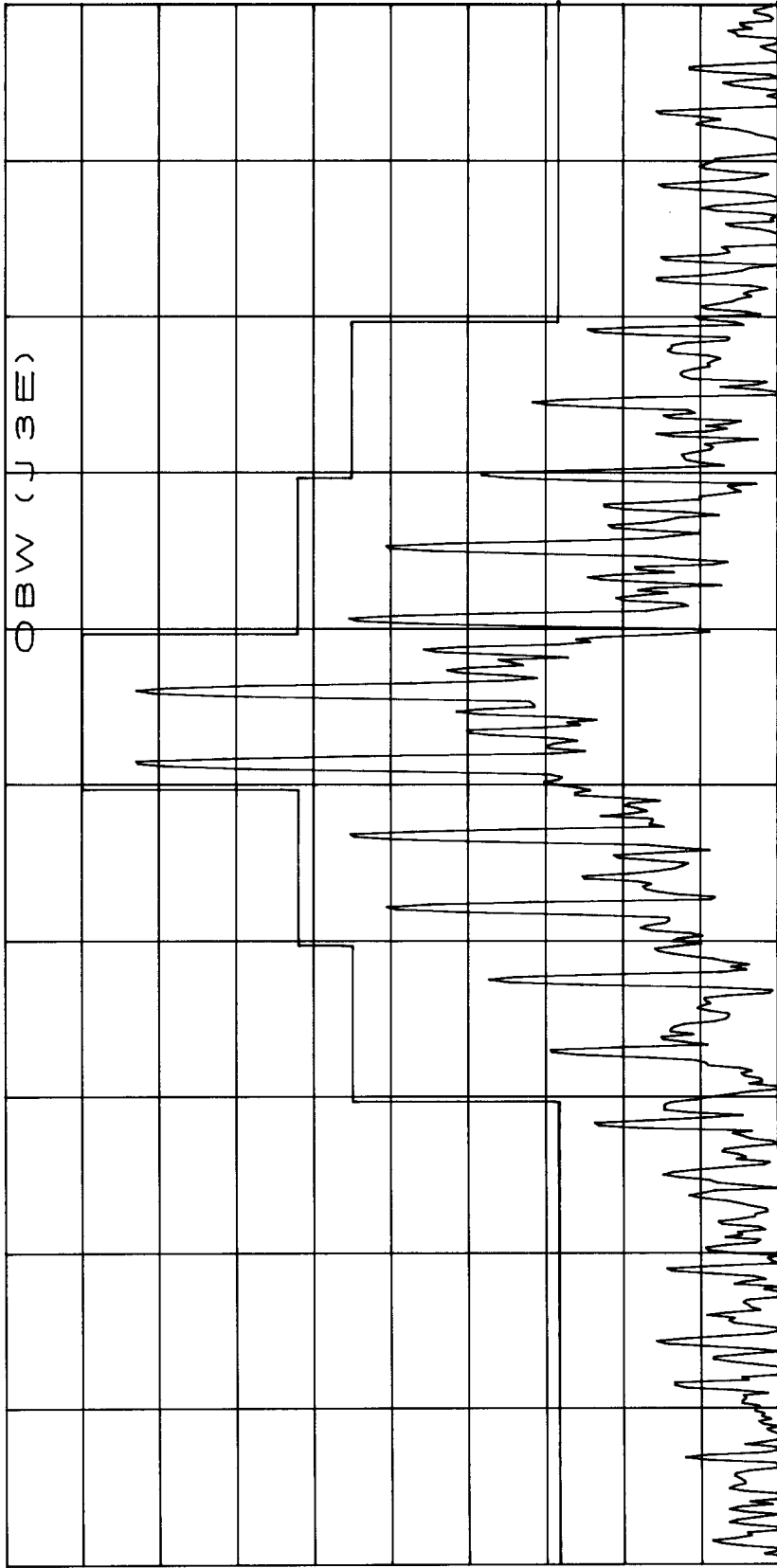

Fig. 2.3.2-21 Occupied bandwidth

Frequency: 6212.0kHz
 Mode: F1B
 Line Voltage: DC 24V

ATTEN 20dB
RL 1.9dBm

10dB/



D

CENTER 8.23800MHZ VBW 100HZ SPAN 30.00KHZ
*RBW 100HZ SWP 3.1sec

Fig. 2.3.2-22 Occupied bandwidth

Frequency: 8238.0kHz
Mode: J3E
Line Voltage: DC 24V

ATTEN 20dB
RL 1.9dBm

10dB/

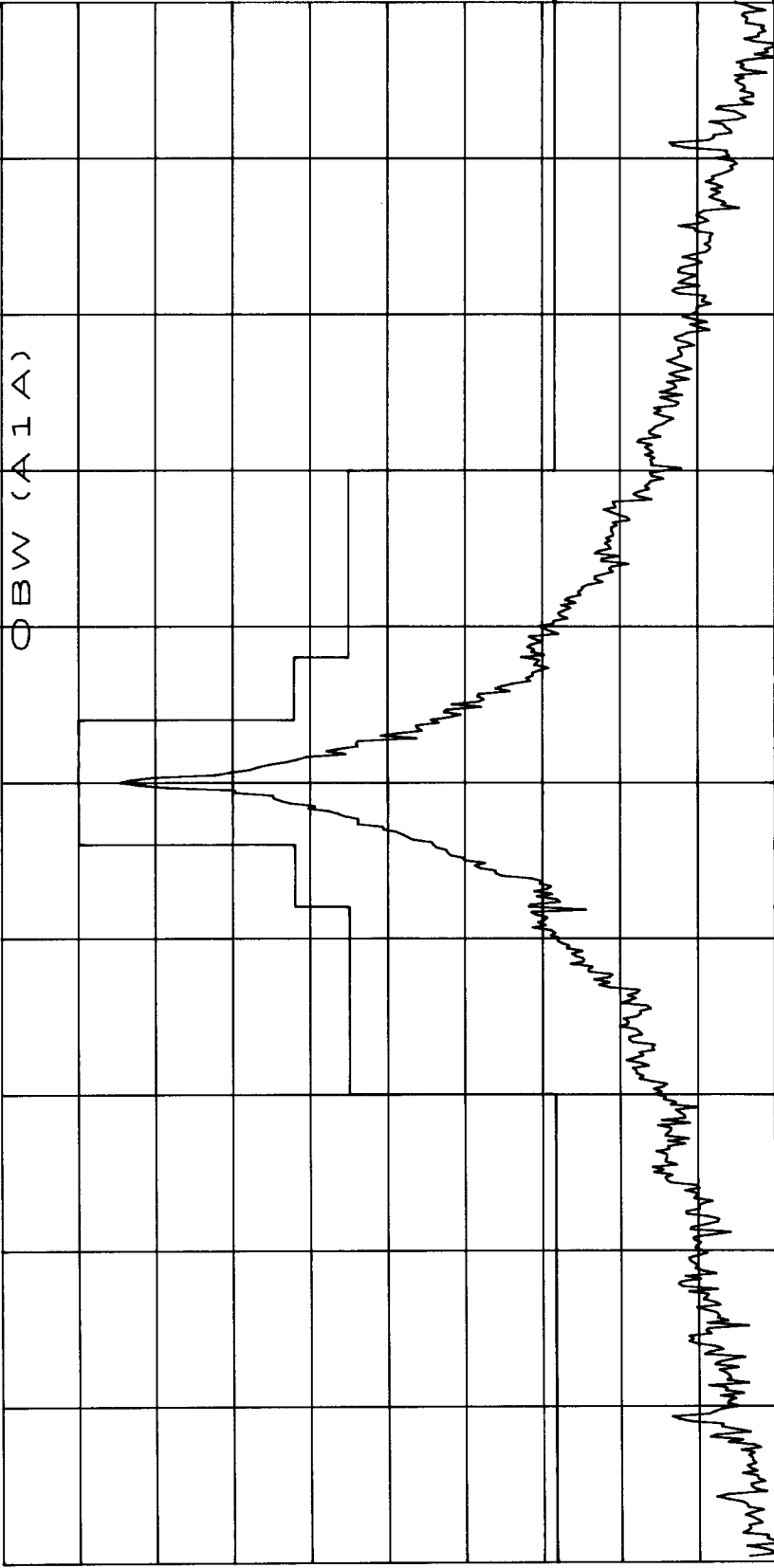

D

CENTER 8.238000MHZ
*RBW 10HZ
SPAN 5.000KHZ
x:SWP 10sec
VBW 10HZ

Fig. 2.3.2-23 Occupied bandwidth

Frequency: 8238.0kHz
Mode: A1A
Line Voltage: DC 24V

ATTEN 20dB

RL 1.9dBm

10dB/

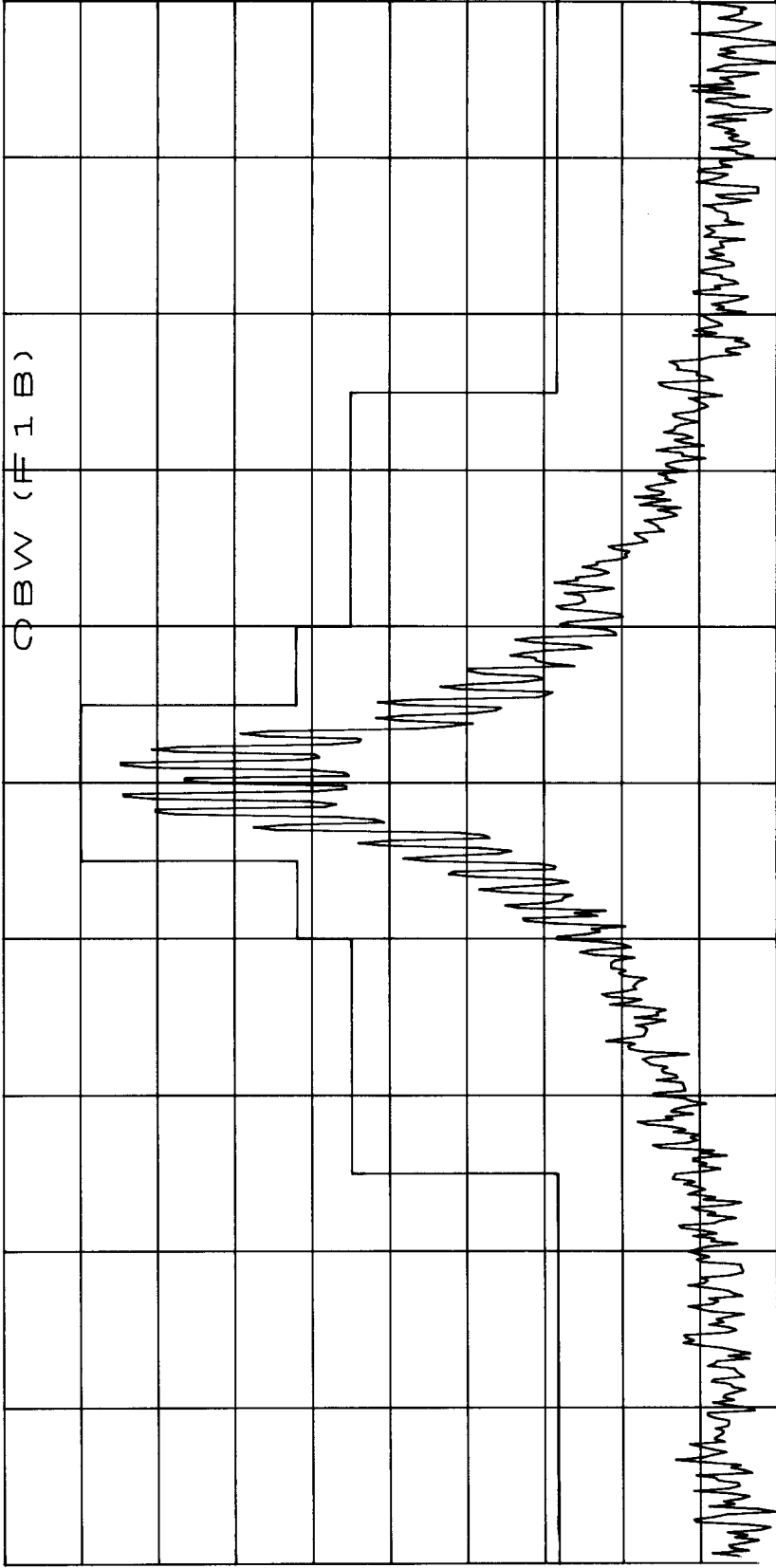

CENTER 8.238000MHZ VBW 10HZ SPAN 5.000KHZ
*RBW 10HZ SWP 30sec

Fig. 2.3.2-24 Occupied bandwidth

Frequency: 8238.0kHz
Mode: F1B
Line Voltage: DC 24V

ATTEN 20dB
RL 1.9dBm

10dB/

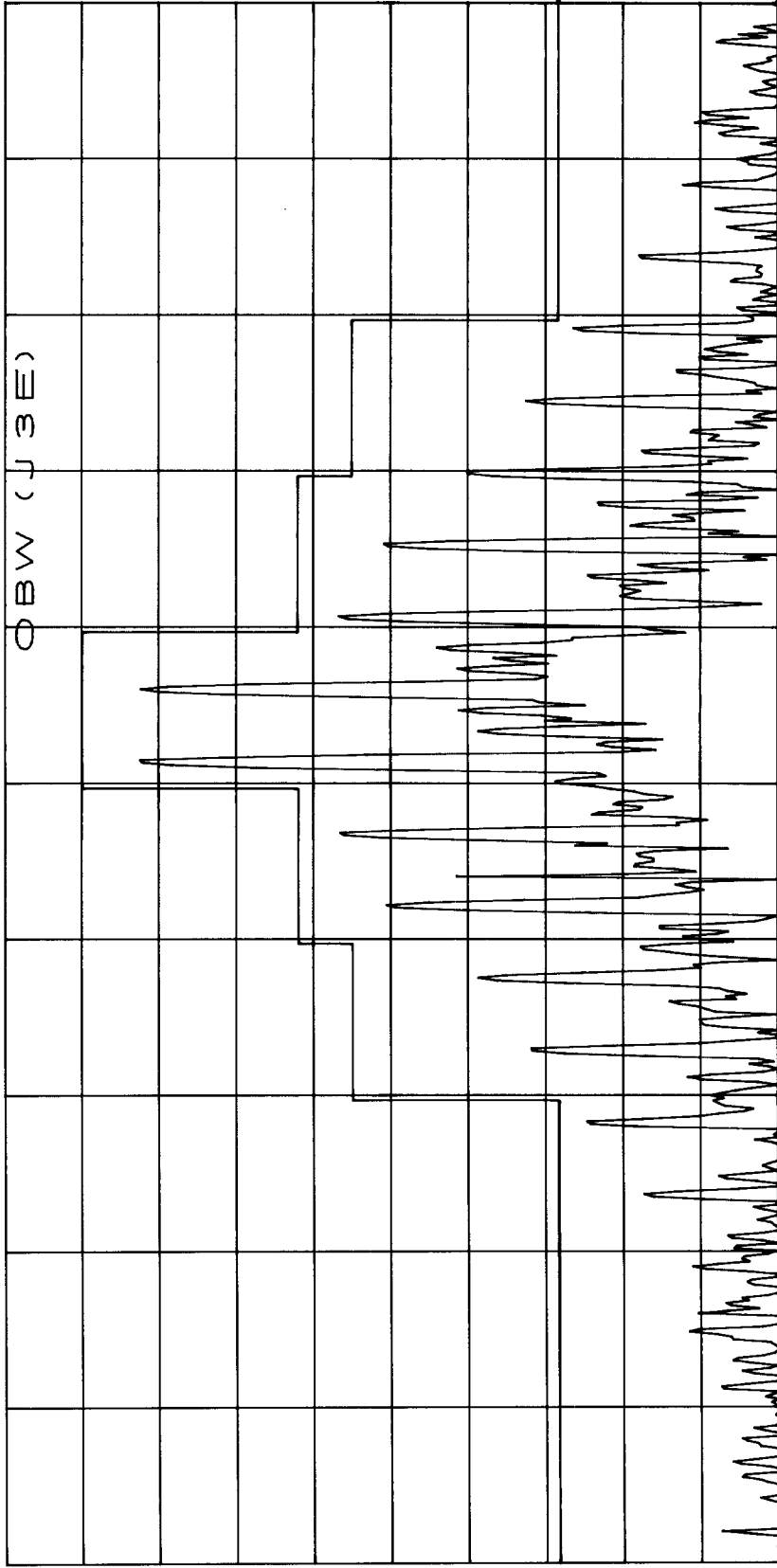

D

CENTER 12.33900MHZ SPAN 30.00KHZ
*RBW 100HZ VBW 100HZ SWP 3.1sec

Fig. 2.3.2-25 Occupied bandwidth

Frequency: 12339.0kHz
Mode: J3E
Line Voltage: DC 24V

ATTEN 20dB
RL 1.9dBm

10dB/

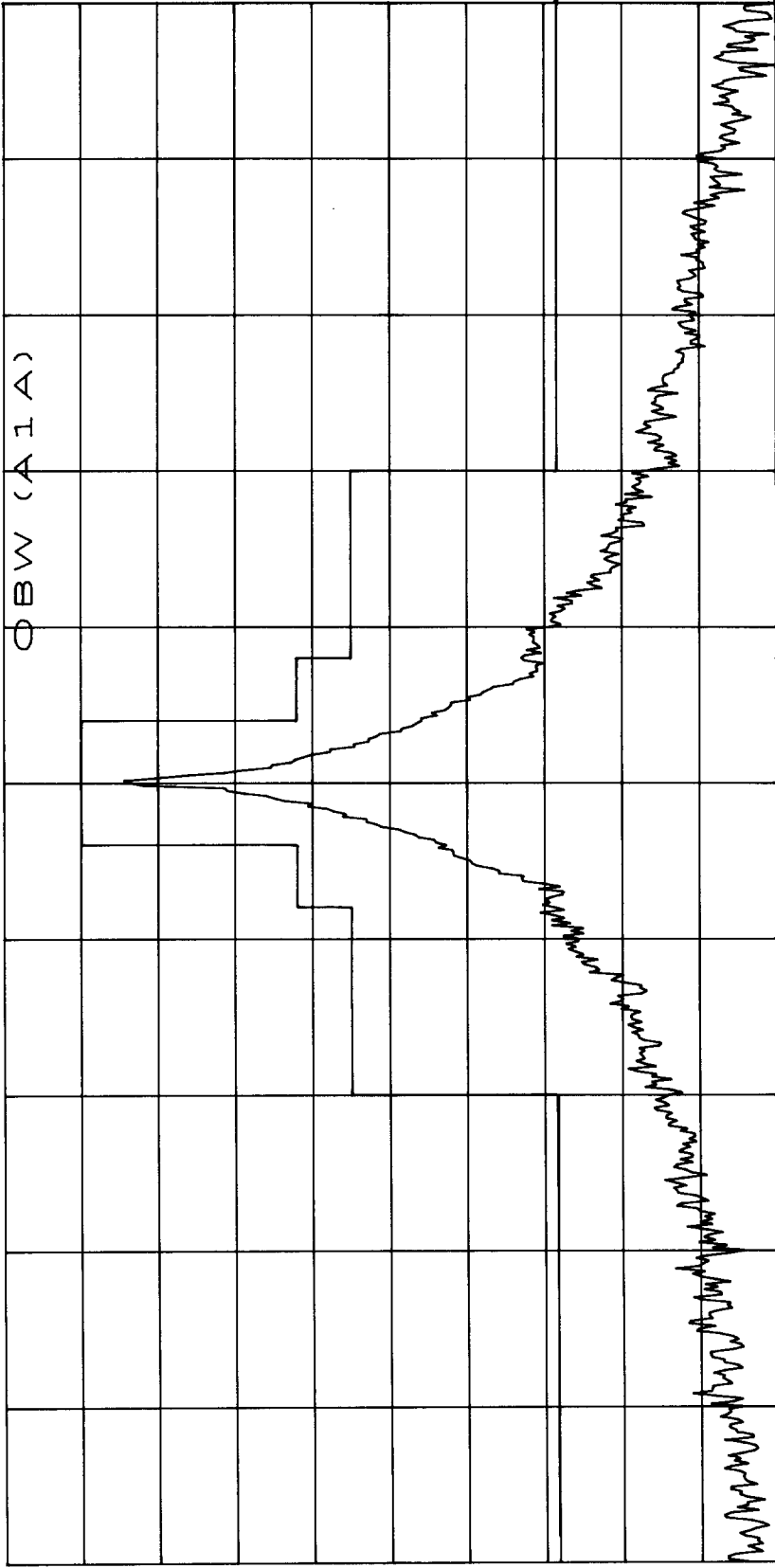

D

CENTER 12.33900MHZ
*RBW 10HZ
SPAN 5.000KHZ
*SWP 10sec
VBW 10HZ

Fig. 2.3.2-26 Occupied bandwidth

Frequency: 12339.0kHz
Mode: A1A
Line Voltage: DC 24V

ATTEN 20dB
RL 1.9dBm

10dB

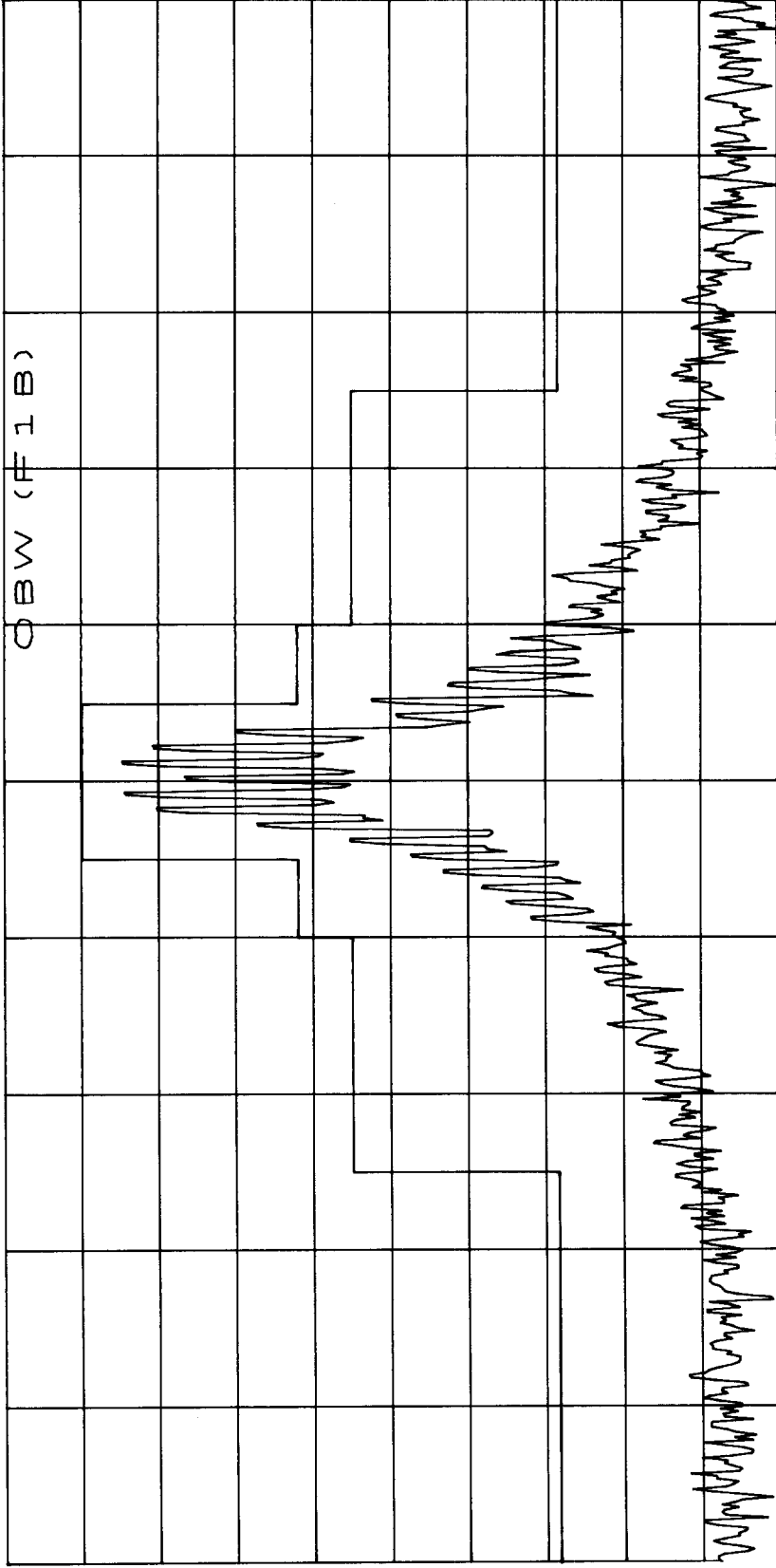

D

CENTER 12.339000MHZ
*RBW 10HZ
OBW (F1B)
SPAN 5.000KHZ
SWP 3.0sec

Fig. 2.3.2-27 Occupied bandwidth

Frequency: 12339.0kHz
Mode: F1B
Line Voltage: DC 24V

ATTEN 20dB
RL 1.9dBm

10dB/

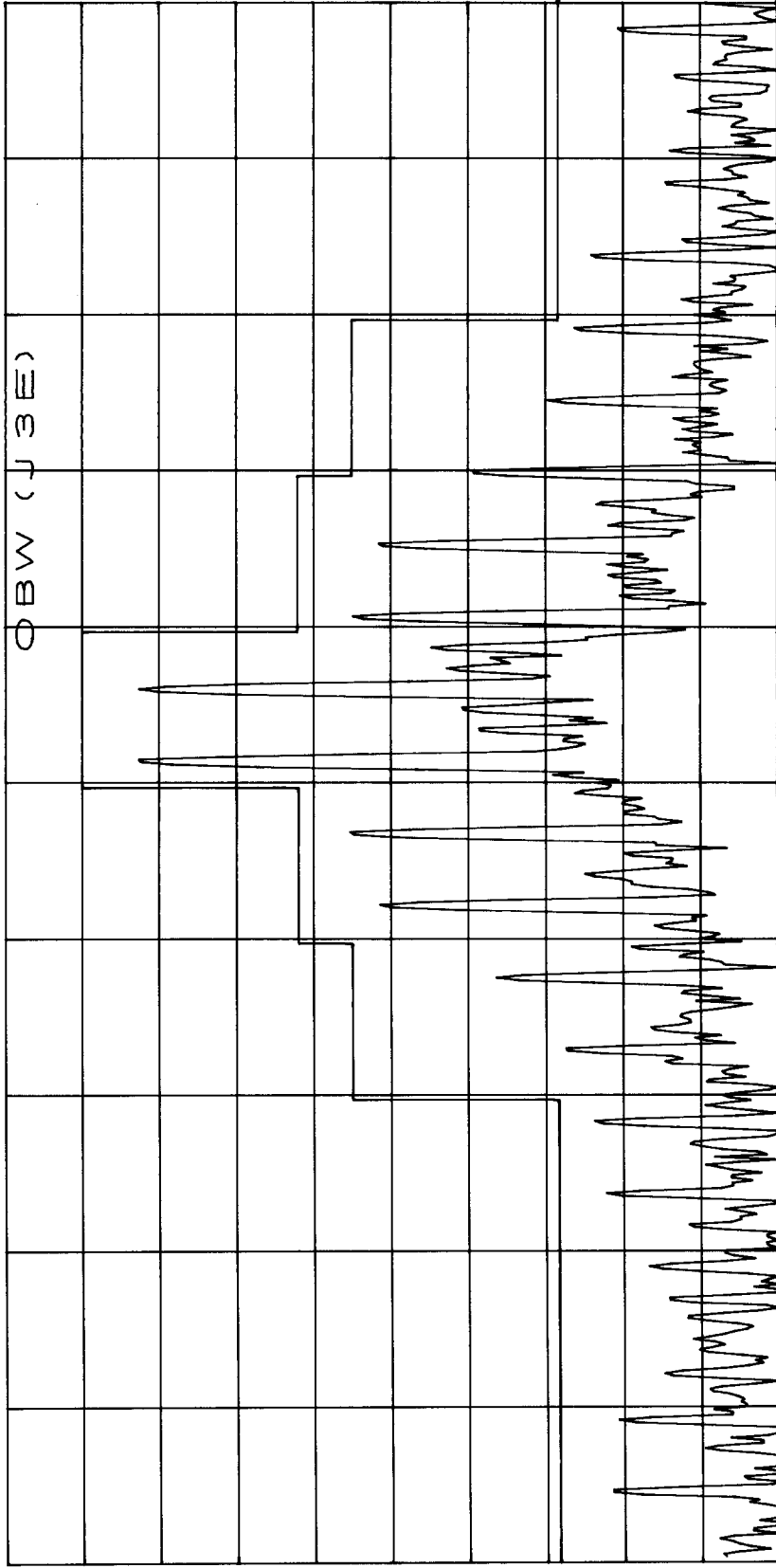

CENTER 16.52500MHZ SPAN 30.00KHZ
*RBW 100HZ VBW 100HZ SWP 3.1sec

Fig. 2.3.2-28 Occupied bandwidth

Frequency: 16525.0kHz
Mode: J3E
Line Voltage: DC 24V

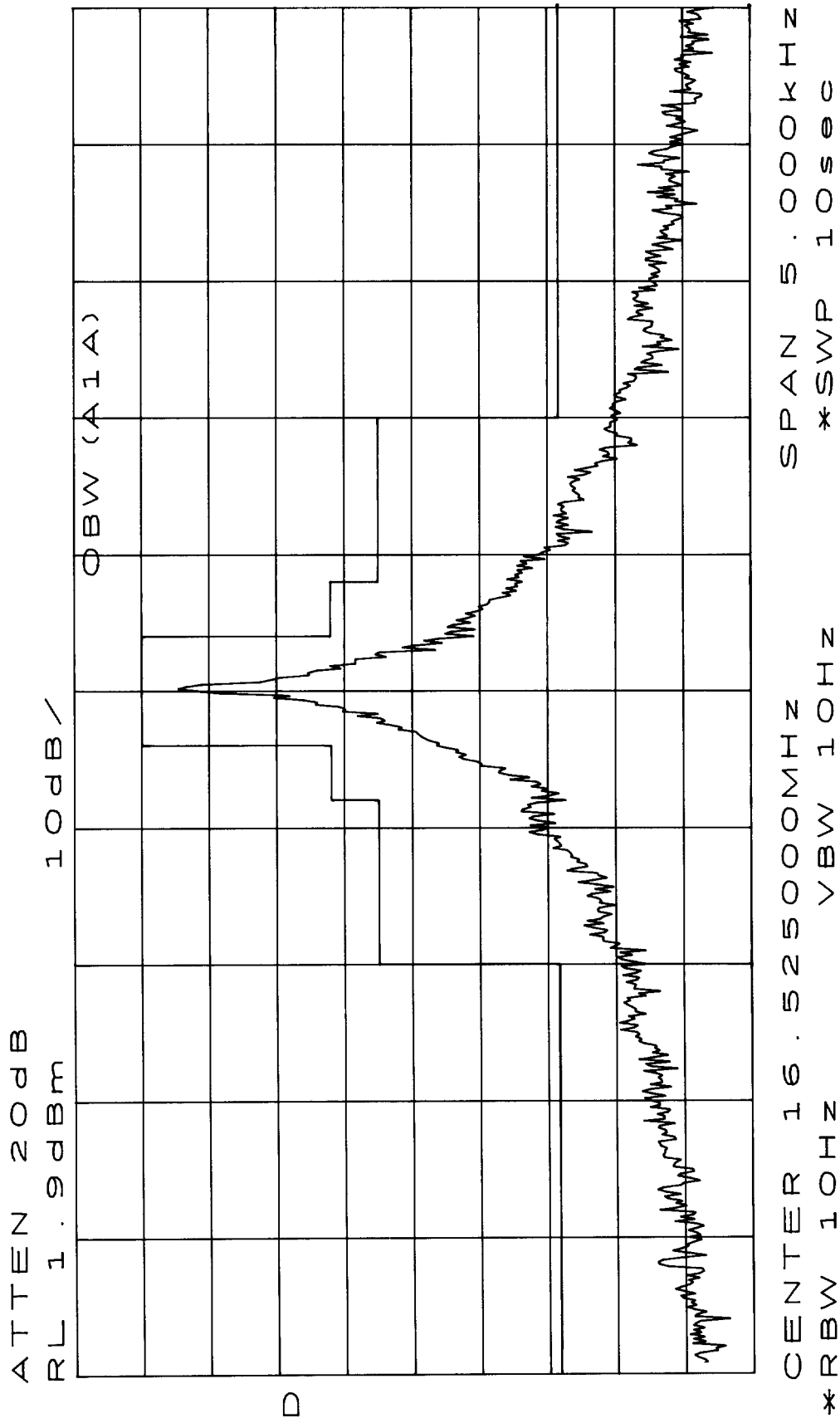
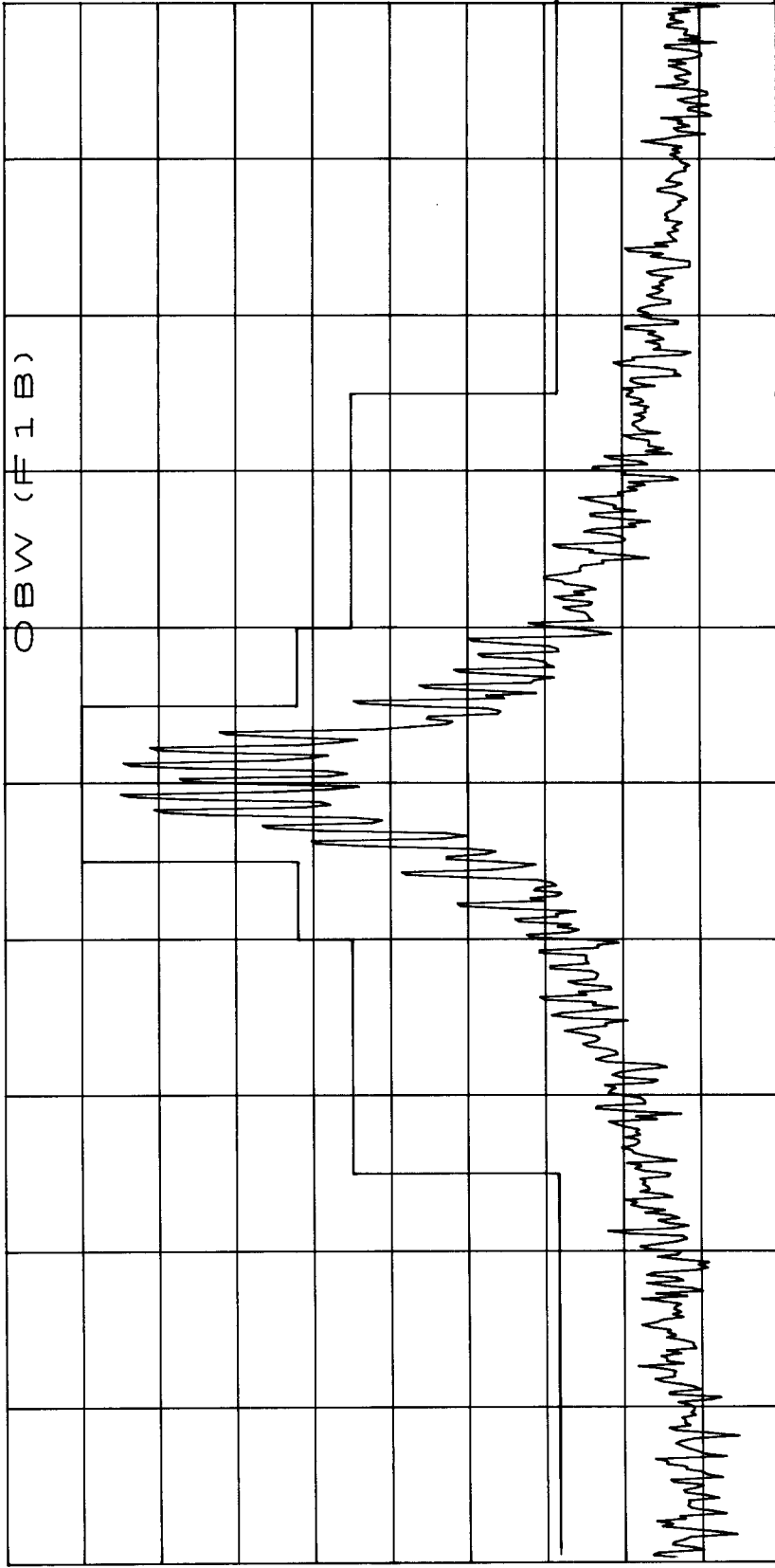

Fig. 2.3.2-29 Occupied bandwidth

Frequency: 16525.0kHz
 Mode: A1A
 Line Voltage: DC 24V

ATTEN 20dB
RL 1.9dBm

10dB/



D

CENTER 16.52500MHZ SPAN 5.000KHZ
*RBW 10HZ VBW 10HZ SWP 3.0sec

Fig. 2.3.2-30 Occupied bandwidth

Frequency: 16525.0kHz
Mode: F1B
Line Voltage: DC 24V

ATTEN 20dB
RL 1.9dBm

10dB/

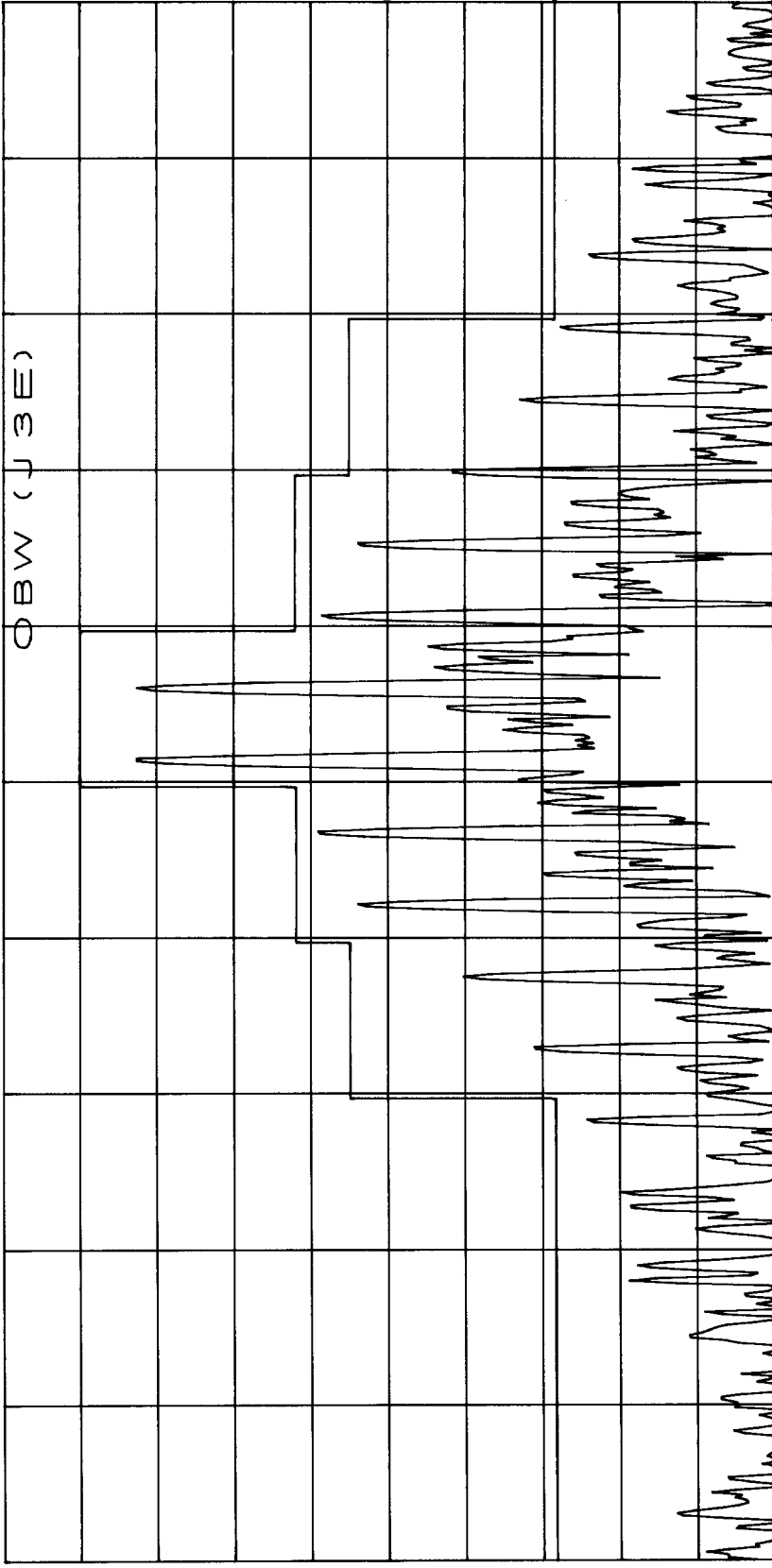

D

CENTER 22.09300MHZ SPAN 30.00KHZ
*RBW 100HZ VBW 100HZ SWP 3.1sec

Fig. 2.3.2-31 Occupied bandwidth

Frequency: 22093.0kHz
Mode: J3E
Line Voltage: DC 24V

ATTEN 20dB
RL 1.9dBm

10dB/

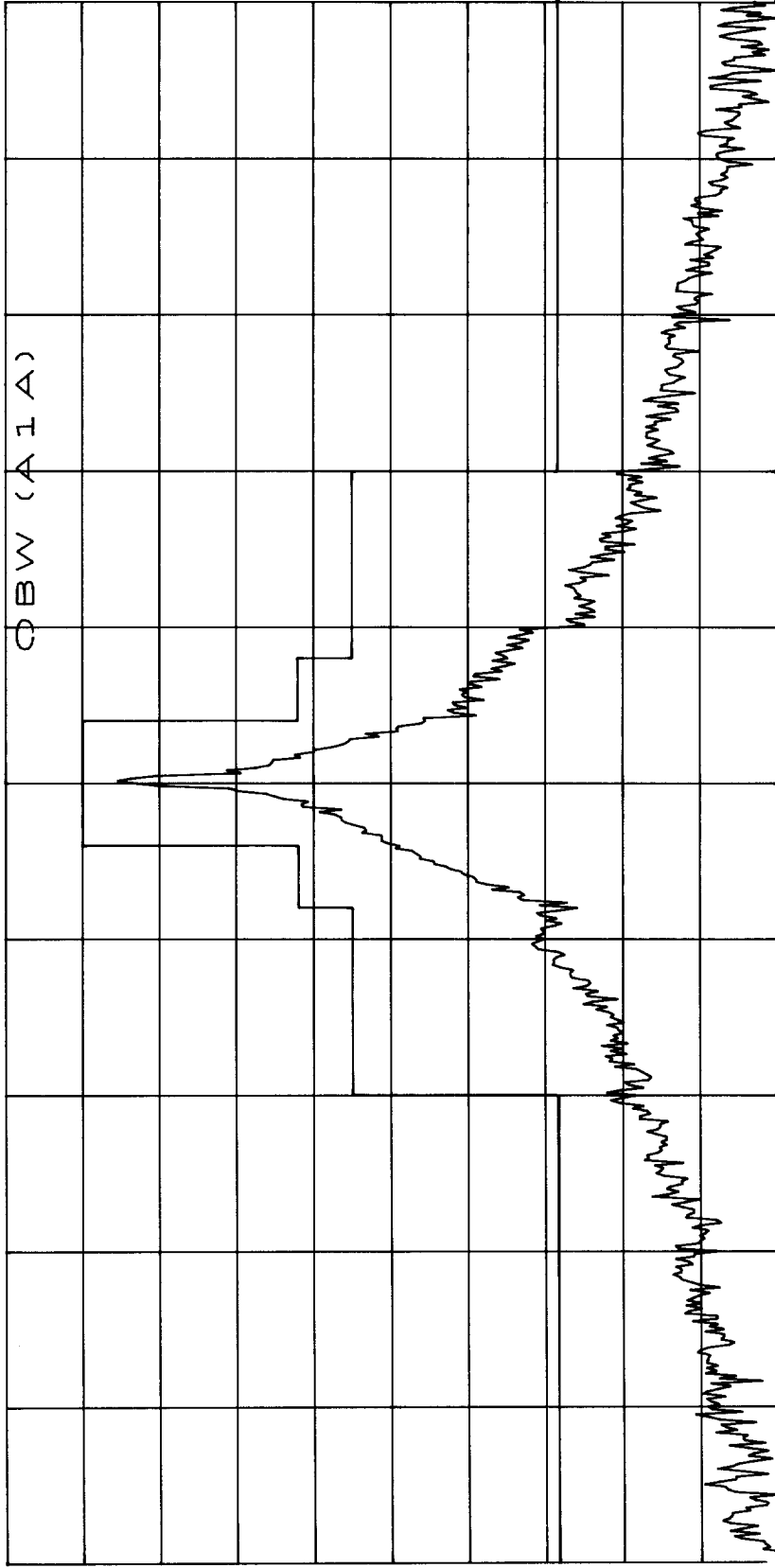

D

CENTER 22.09300MHZ
*RBW 10HZ
SPAN 5.000KHZ
*SWP 10sec
VBW 10HZ

Fig. 2.3.2-32 Occupied bandwidth

Frequency: 22093.0kHz
Mode: A1A
Line Voltage: DC 24V

ATTEN 20dB
RL 1.9dBm

10dB/

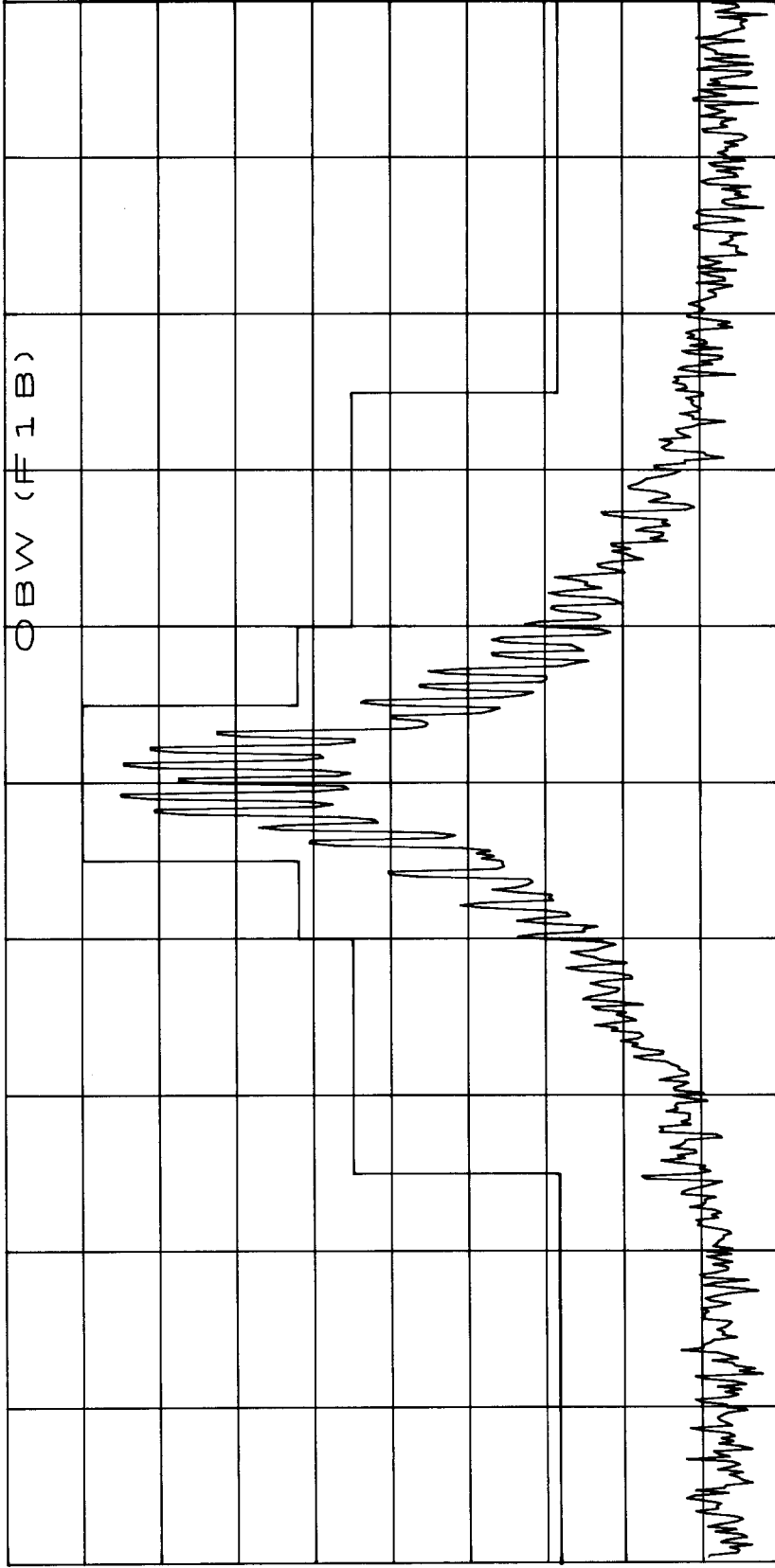

CENTER 22.093000MHZ SPAN 5.000KHZ
* RBW 10HZ VBW 10HZ SWP 3.00sec

Fig. 2.3.2-33 Occupied bandwidth

Frequency: 22093.0kHz
Mode: F1B
Line Voltage: DC 24V

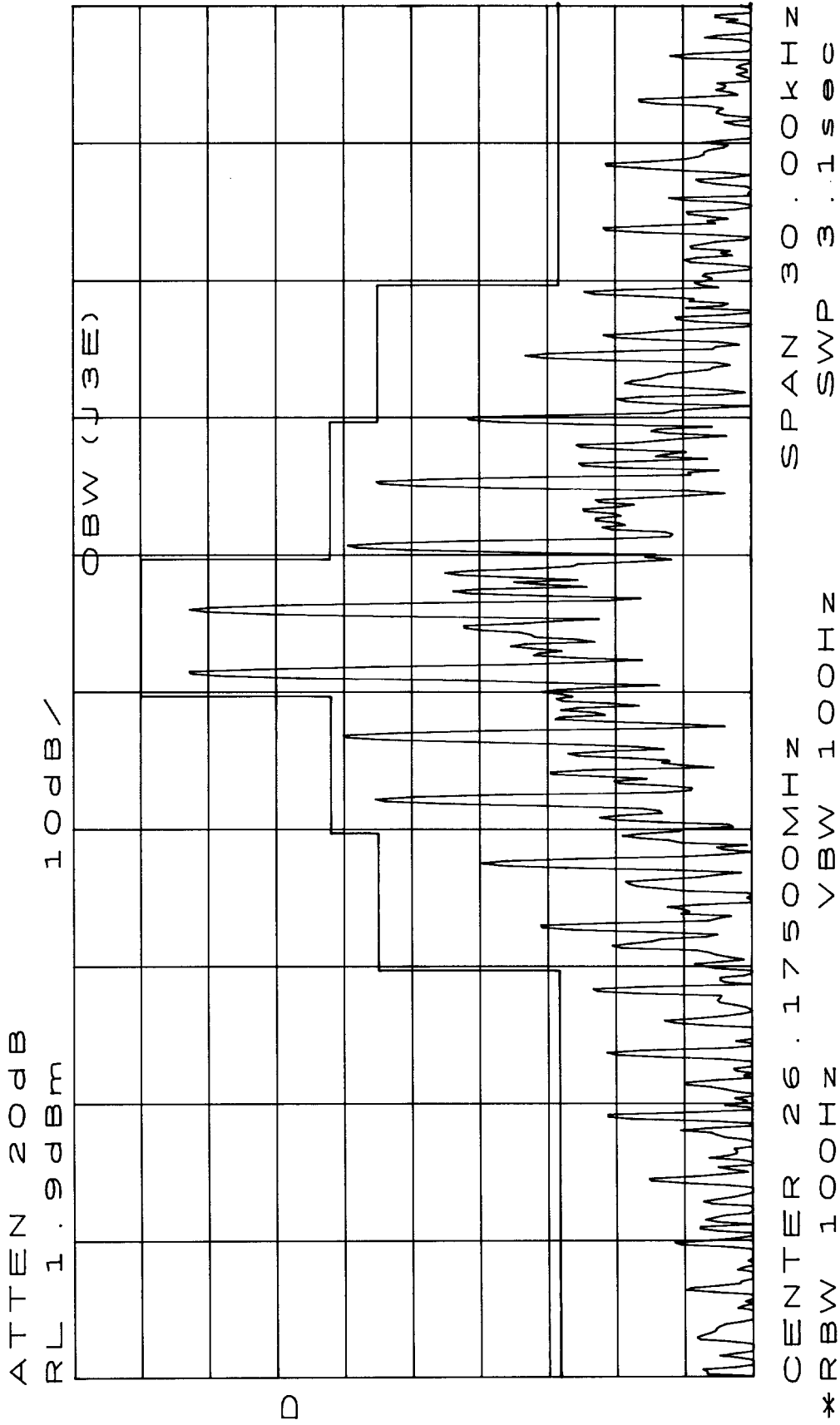
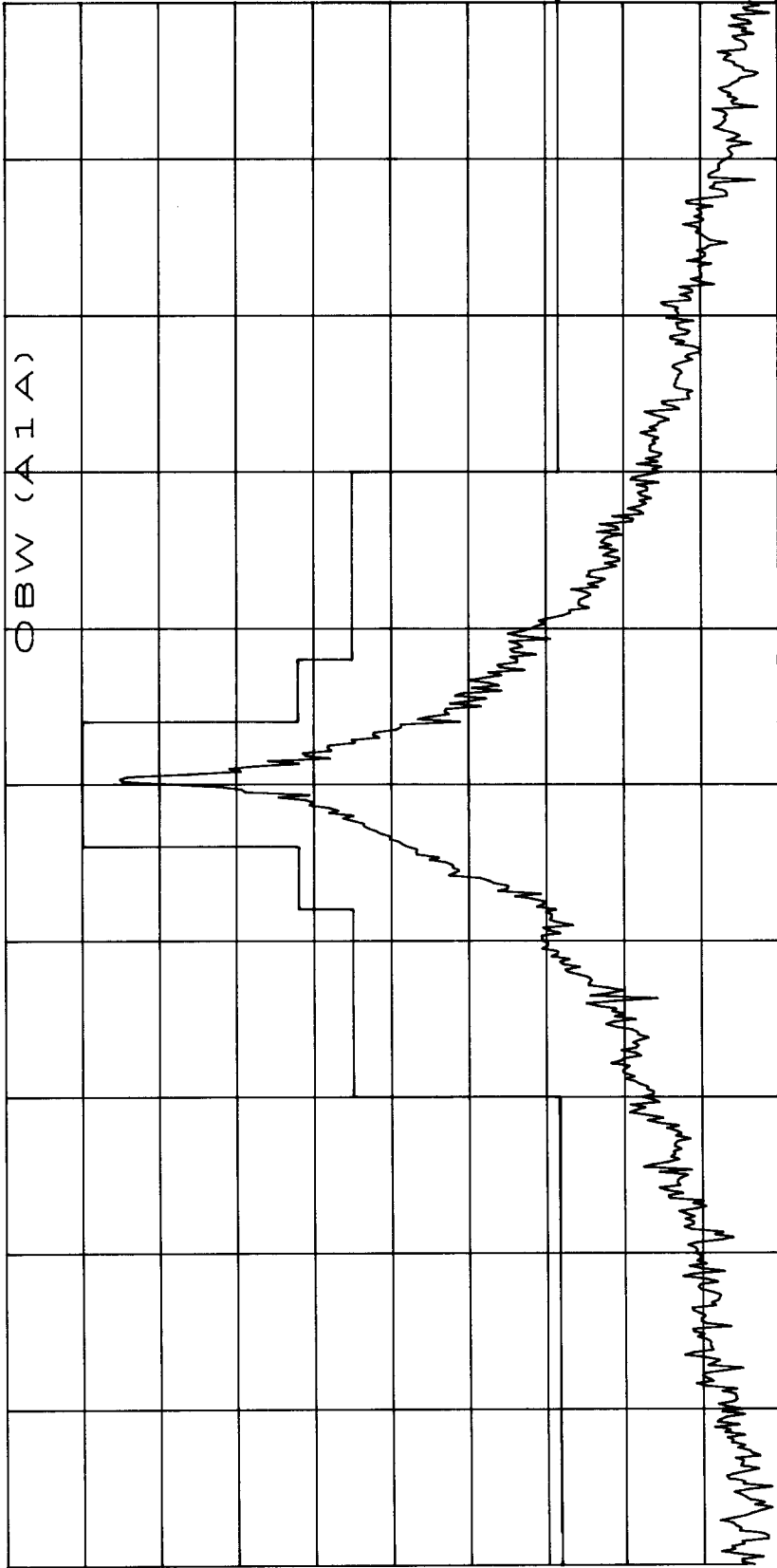

Fig. 2.3.2-34 Occupied bandwidth

Frequency: 26175.0kHz
 Mode: J3E
 Line Voltage: DC 24V

ATTEN 20dB
RL 1.9dBm

10dB/



CENTER 26.17500MHZ
*RBW 10HZ
SPAN 5.000KHZ
*SWP 10sec
VBW 10HZ

Fig. 2.3.2-35 Occupied bandwidth

Frequency: 26175.0kHz
Mode: A1A
Line Voltage: DC 24V

ATTEN 20dB
RL 1.9dBm

10dB

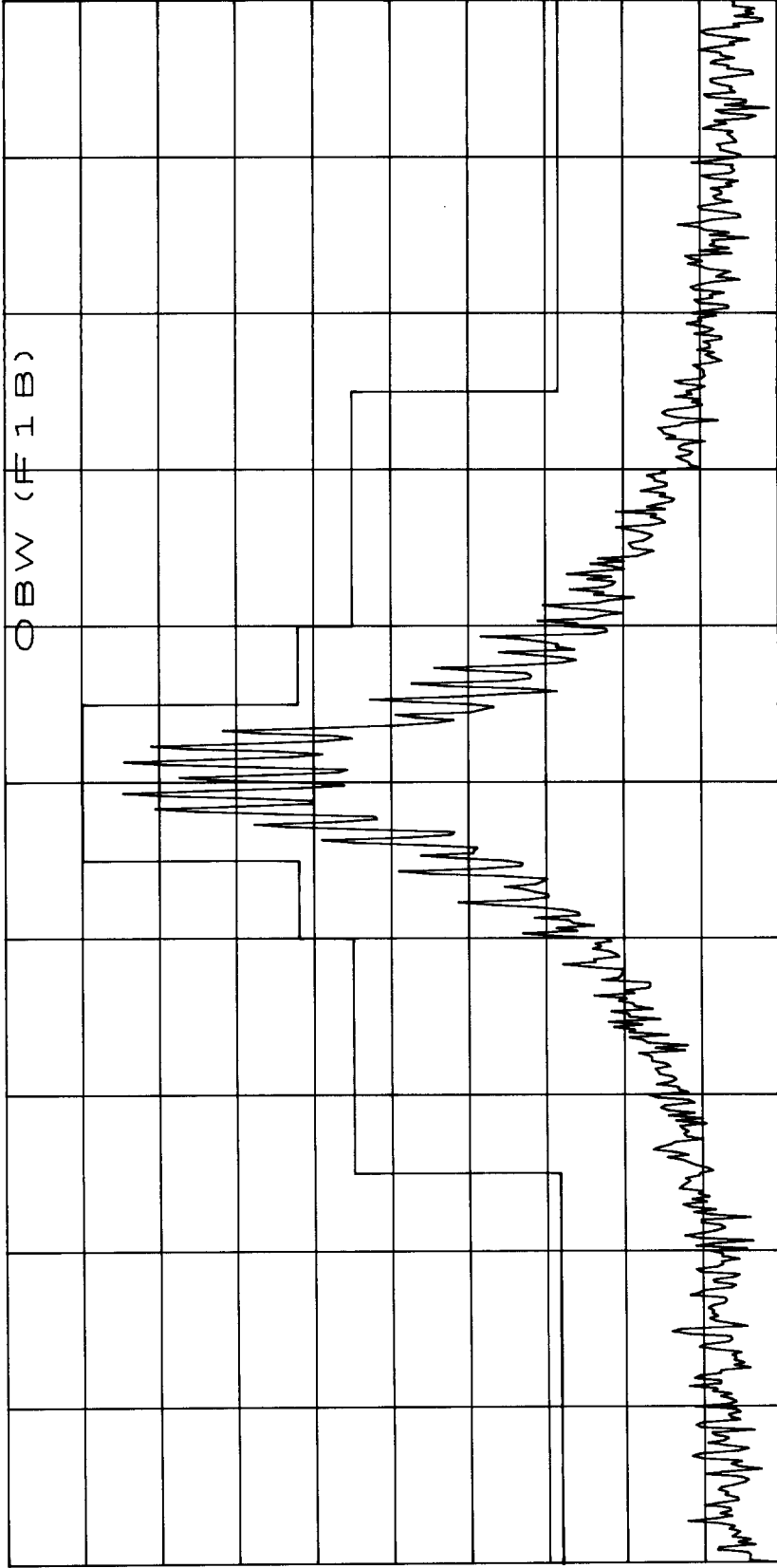

D

CENTER 26.17500MHZ
*RBW 10HZ
SPAN 5.000KHZ
SWP 3.0sec
VBW 10HZ

Fig. 2.3.2-36 Occupied bandwidth

Frequency: 26175.0kHz
Mode: F1B
Line Voltage: DC 24V

2.4 Spurious emissions at antenna terminal [FCC § 2.1051, § 80.211(a),(f)]

2.4.1 Test procedure

The Radio Equipment JSB-196GM was connected as shown in Fig. 2.4.1-1.

The equipment under test was operated in J3E mode and in all cases. The J3E modulation level was shown in Fig. 2.2.2.2-1 of the Modulation limiting characteristics. The J3E audio input level was constant at 10dB over the rated output power as per § 2.1047(c). The output spectrum was investigated for the worst case in the frequency range of the transmitter, and the output form was commensurable with that shown in section 2.1 and 2.2 of this test data.

The equipment was tested in J3E mode included in the transmitter frequency range.

2.4.2 Test results

The results are shown from Fig. 2.4.2-1 to Fig. 2.4.2-12.

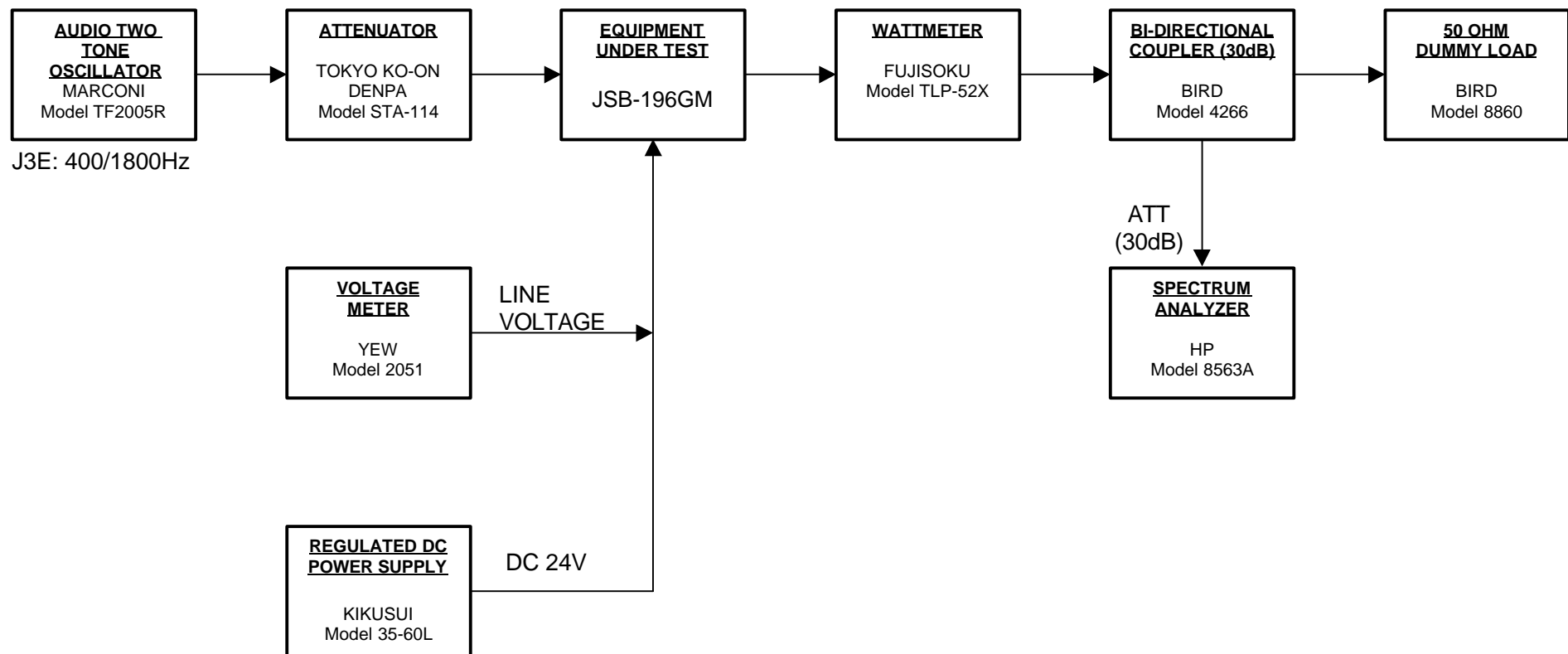
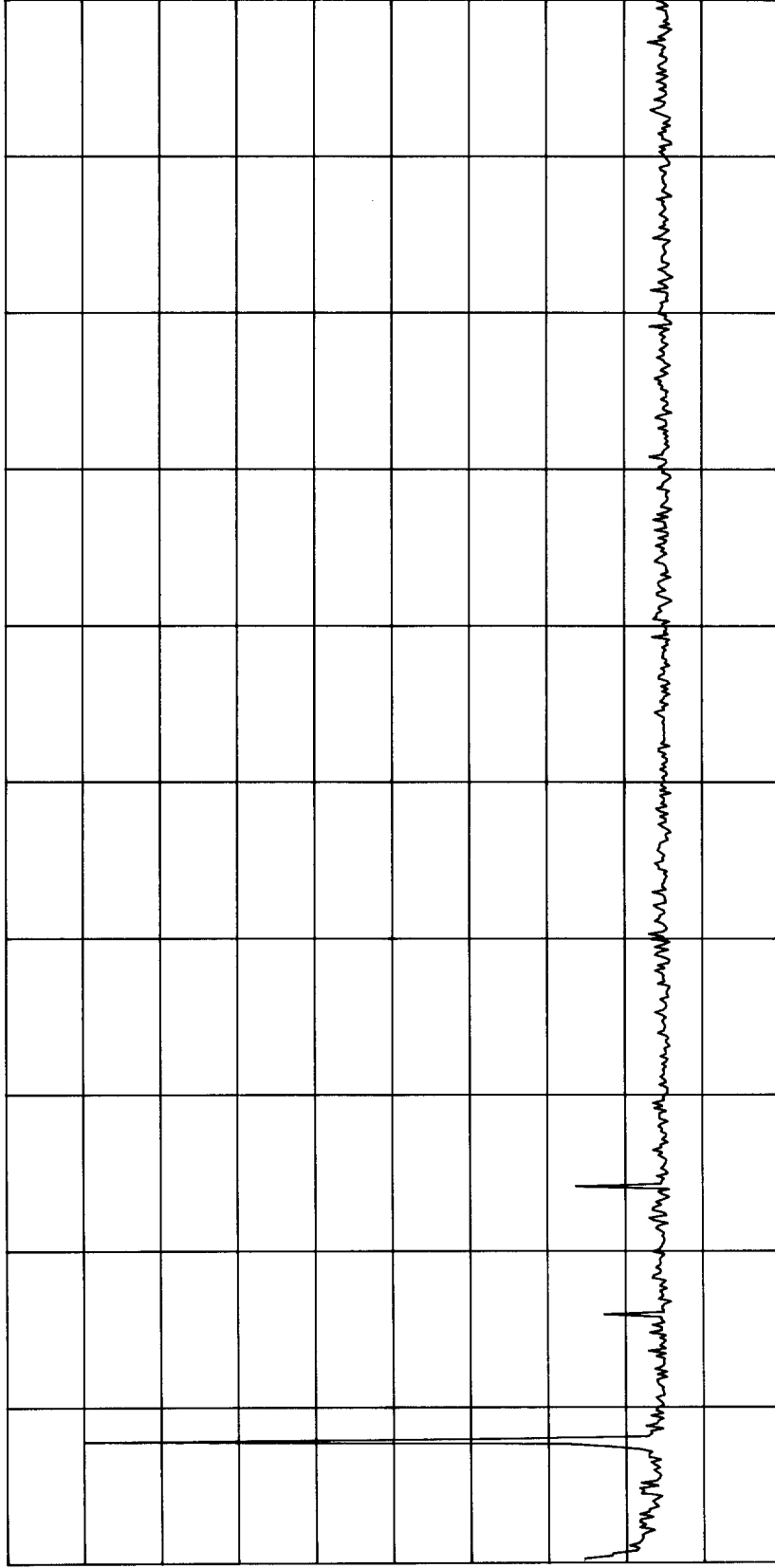

Fig. 2.4.1-1 Test set up for Spurious emissions at antenna terminal

ATTEN 20dB
RL 1.9dBm

10dB/



D

CENTER 10.00MHZ V BW 3.0KHZ SPAN 20.00MHZ
* RBW 3.0KHZ SWP 5.6sec

Fig. 2.4.2-1 Spurious emissions at antenna terminal

Frequency: 1619.0kHz
Mode: J3E
Line Voltage: DC 24V

ATTEN 20dB
RL 1.9dBm

10dB/

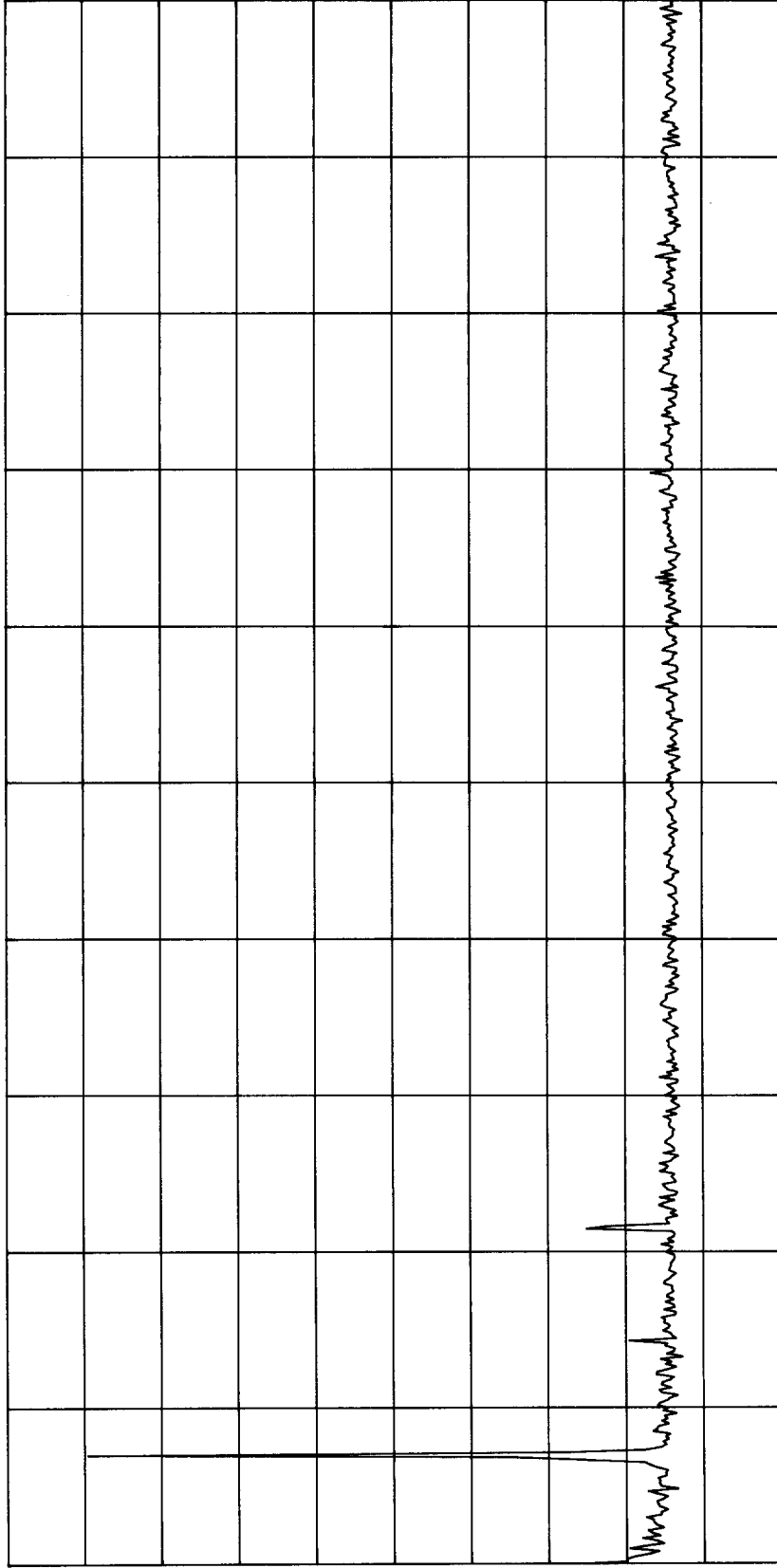

D

CENTER 15.00MHz VBW 3.0kHz SPAN 30.00MHz
*RBW 3.0kHz SWP 8.4sec

Fig. 2.4.2-2 Spurious emissions at antenna terminal

Frequency: 2182.0kHz
Mode: J3E
Line Voltage: DC 24V

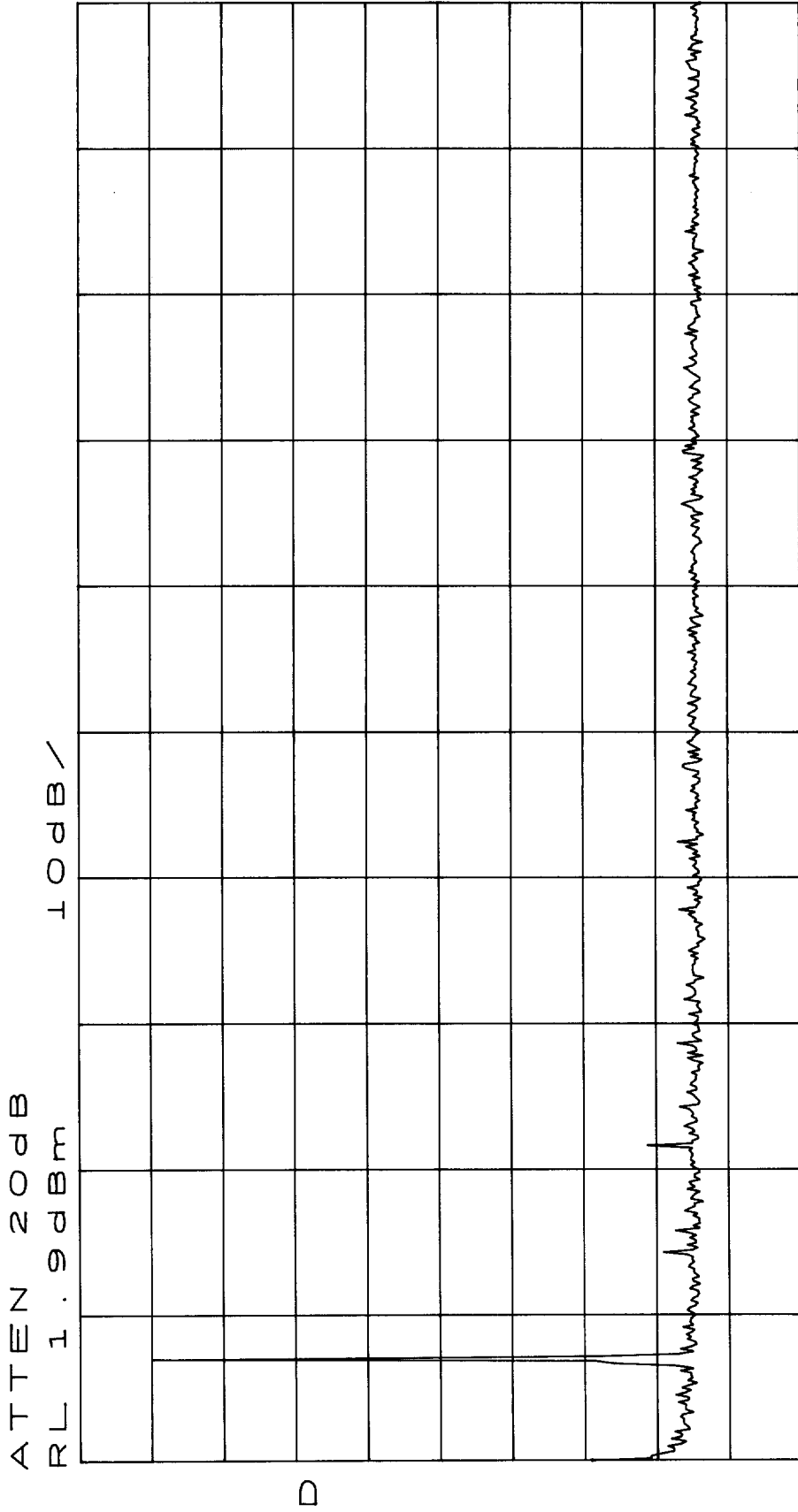
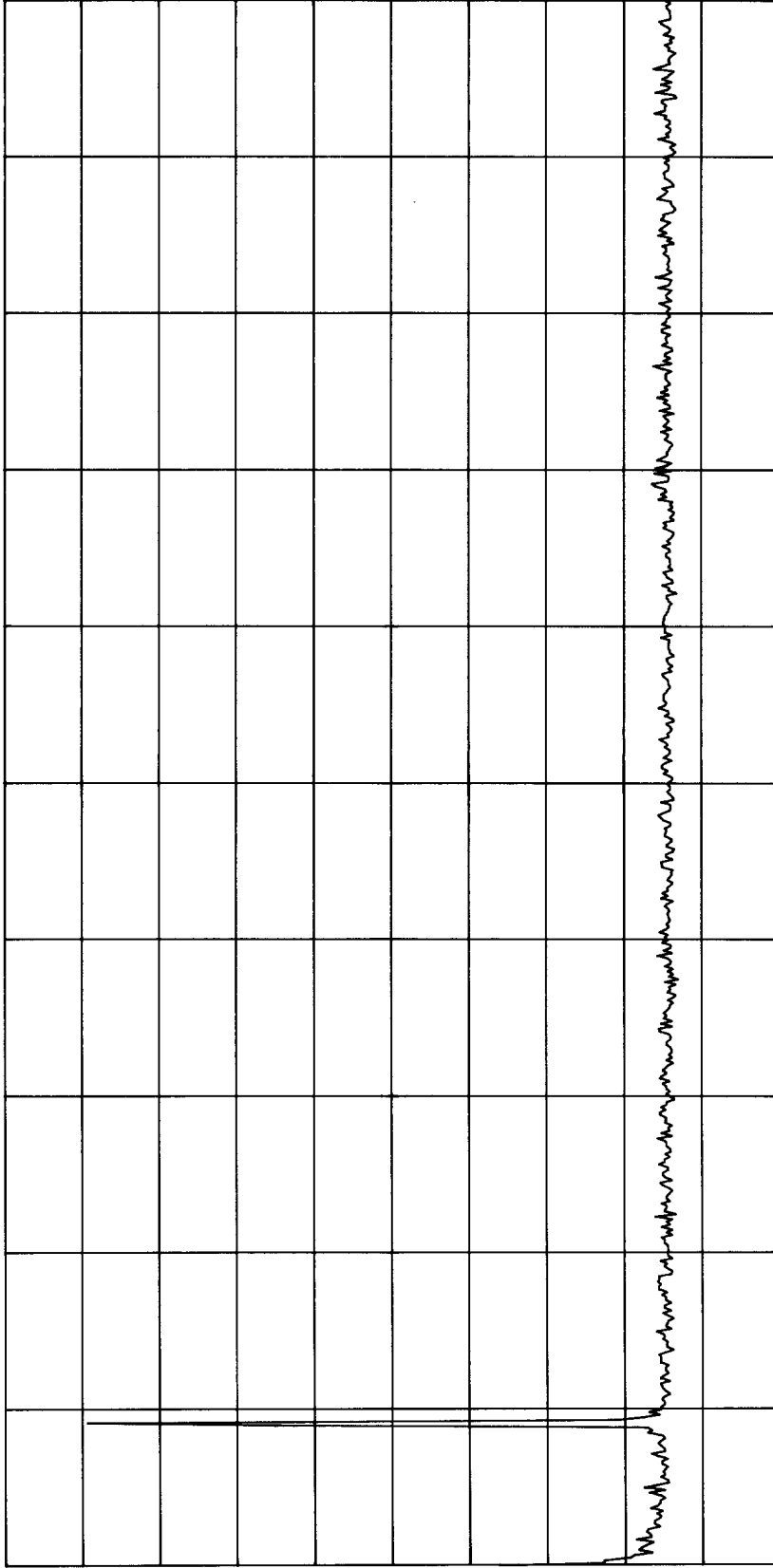

Fig. 2.4.2-3 Spurious emissions at antenna terminal

Frequency: 2187.5kHz
Mode: J3E
Line Voltage: DC 24V

ATTEN 20dB
RL 1.9dBm

10dB/



D

CENTER 15.00MHz VBW 3.0kHz SPAN 30.00MHz
*RBW 3.0kHz SWP 8.4sec

Fig. 2.4.2-4 Spurious emissions at antenna terminal

Frequency: 2830.0kHz
Mode: J3E
Line Voltage: DC 24V

ATTEN 20dB
RL 1.9dBm

10dB/

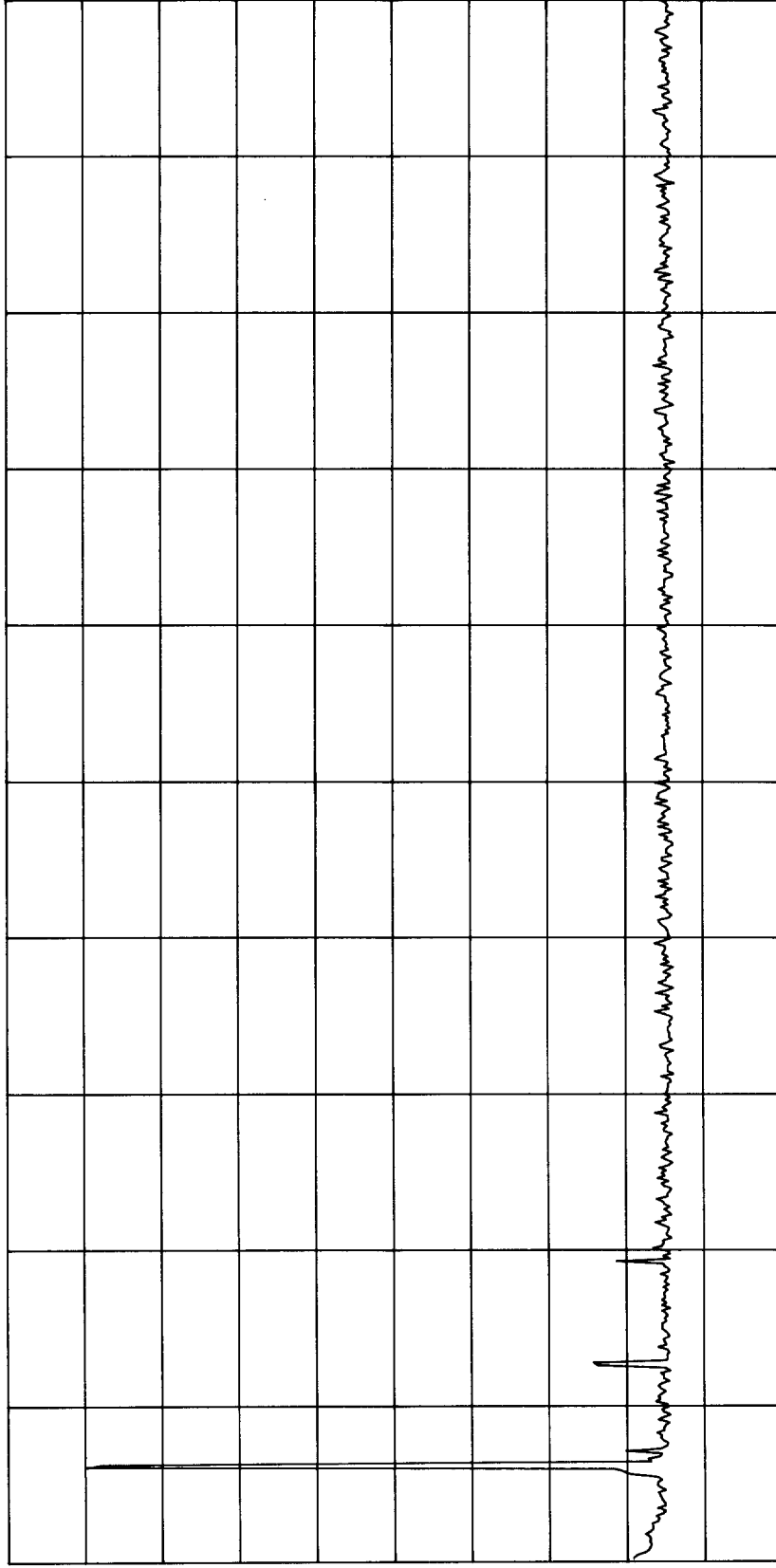

D

CENTER 25.00MHz VBW 3.0kHz SPAN 50.00MHz
*RBW 3.0kHz SWP 14sec

Fig. 2.4.2-5 Spurious emissions at antenna terminal

Frequency: 3258.0kHz
Mode: J3E
Line Voltage: DC 24V

ATTEN 20dB
RL 1.9dBm

10dB/

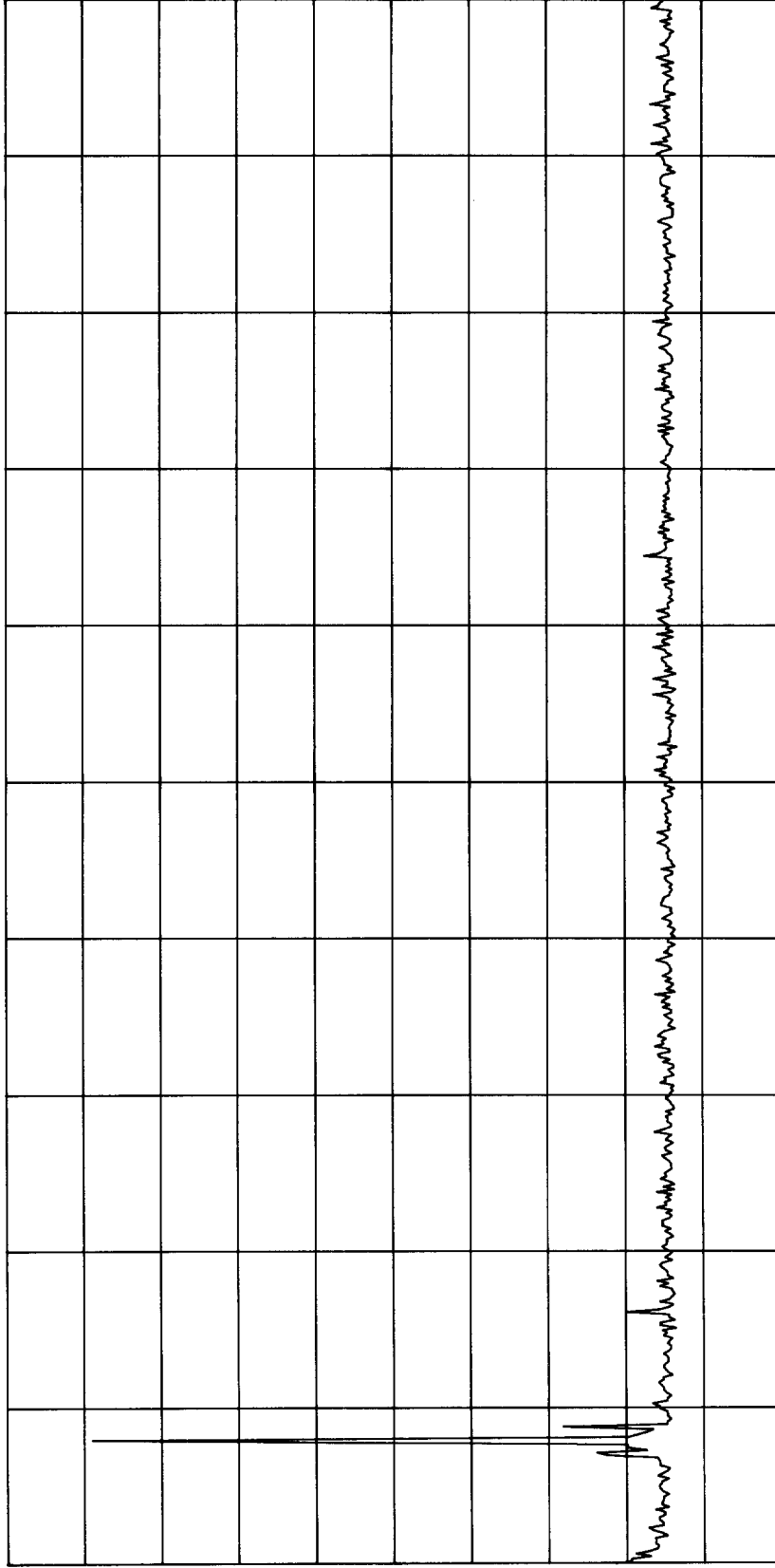

D

CENTER 25.00MHz SPAN 50.00MHz
*RBW 3.0kHz VBW 3.0kHz SWP 14sec

Fig. 2.4.2-6 Spurious emissions at antenna terminal

Frequency: 4112.0kHz
Mode: J3E
Line Voltage: DC 24V

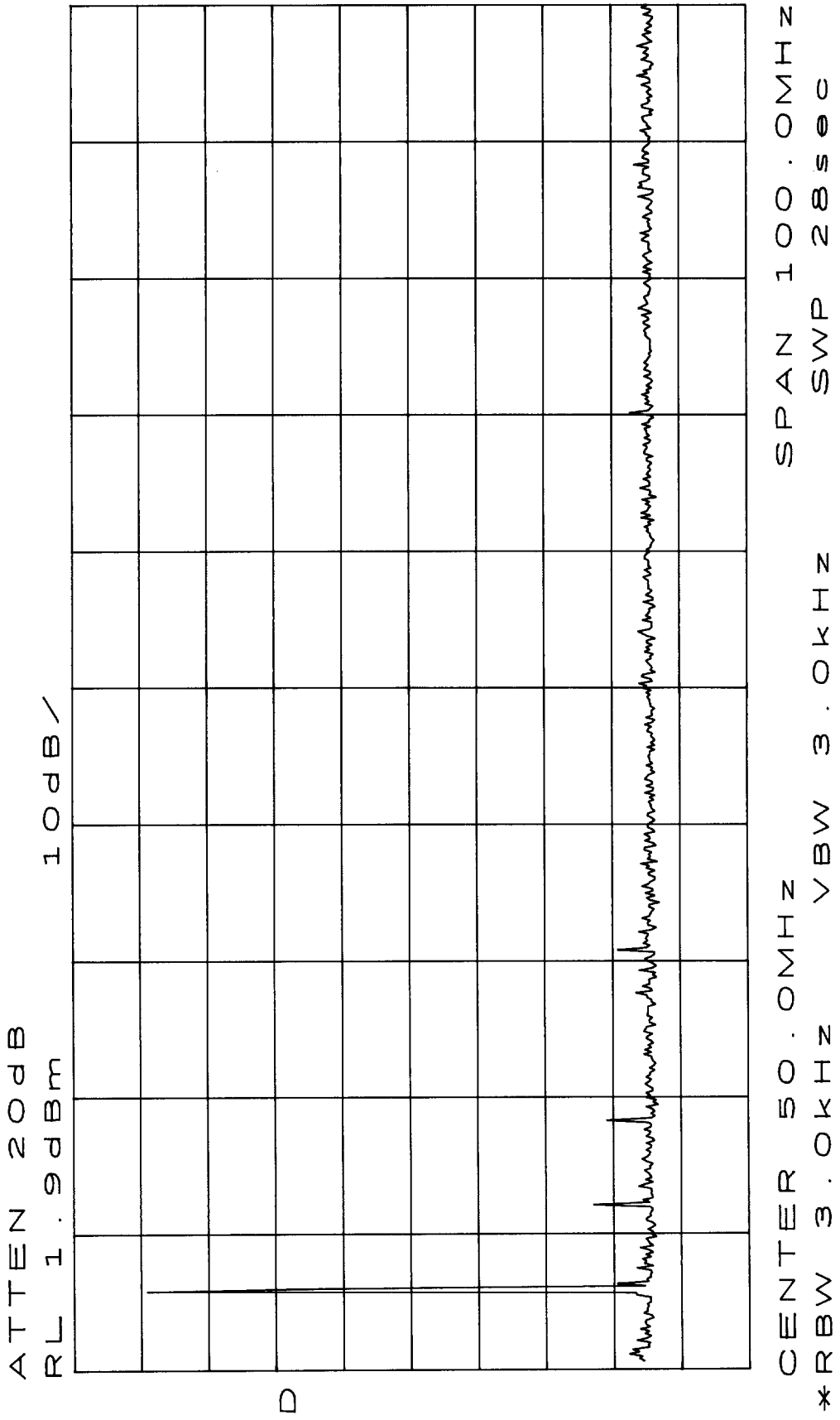
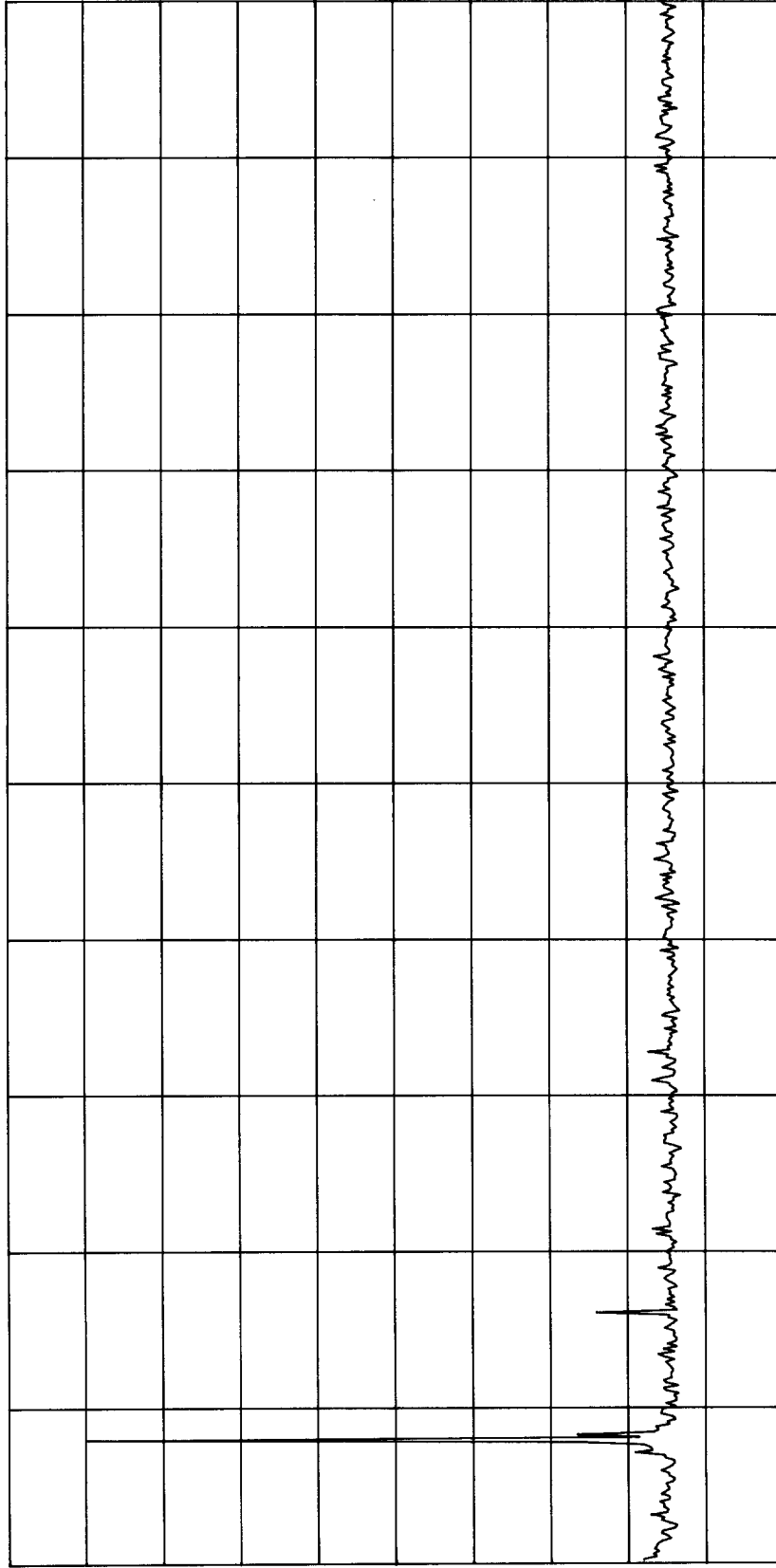

Fig. 2.4.2-7 Spurious emissions at antenna terminal

Frequency: 6212.0kHz
Mode: J3E
Line Voltage: DC 24V

ATTEN 20dB
RL 1.9dBm

10dB/



D

CENTER 50.0MHz V BW 3.0kHz SPAN 100.0MHz
*RBW 3.0kHz SWP 28sec

Fig. 2.4.2-8 Spurious emissions at antenna terminal

Frequency: 8238.0kHz
Mode: J3E
Line Voltage: DC 24V

ATTEN 20dB
RL 1.9dBm

10dB/

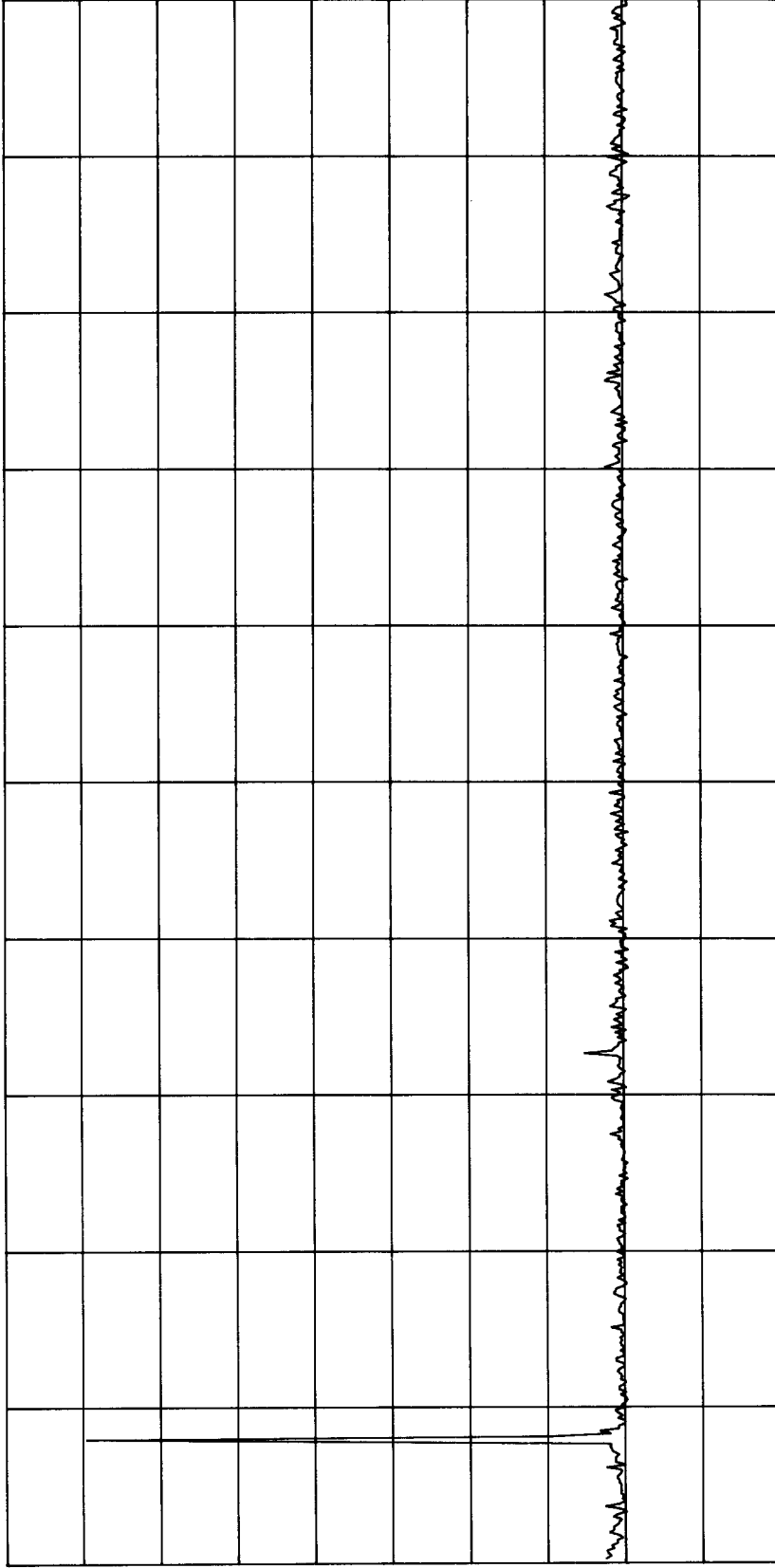

D

CENTER 75.0MHz V BW 10kHz SPAN 150.0MHz
*RBW 10kHz SWP 3.8sec

Fig. 2.4.2-9 Spurious emissions at antenna terminal

Frequency: 12339.0kHz
Mode: J3E
Line Voltage: DC 24V

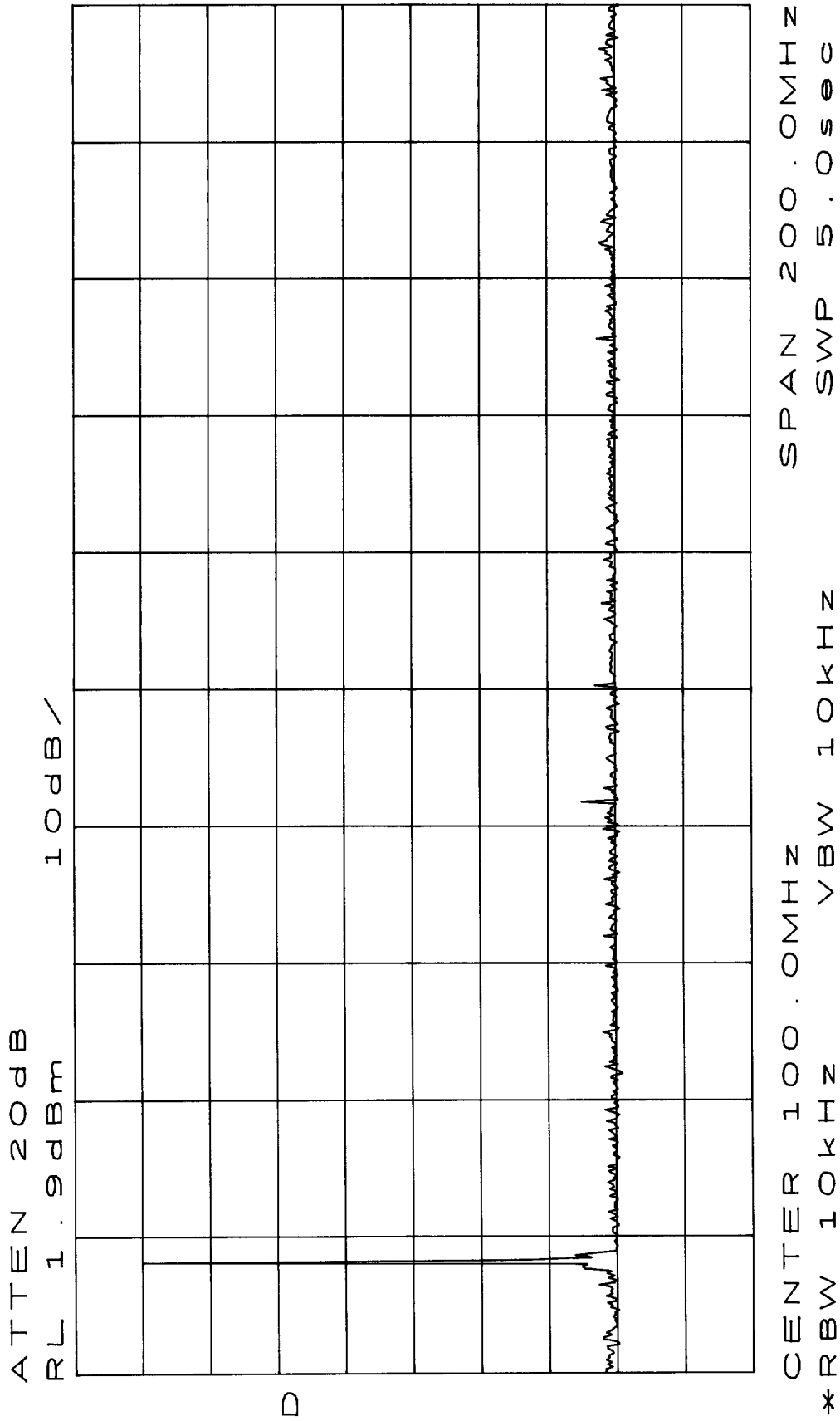
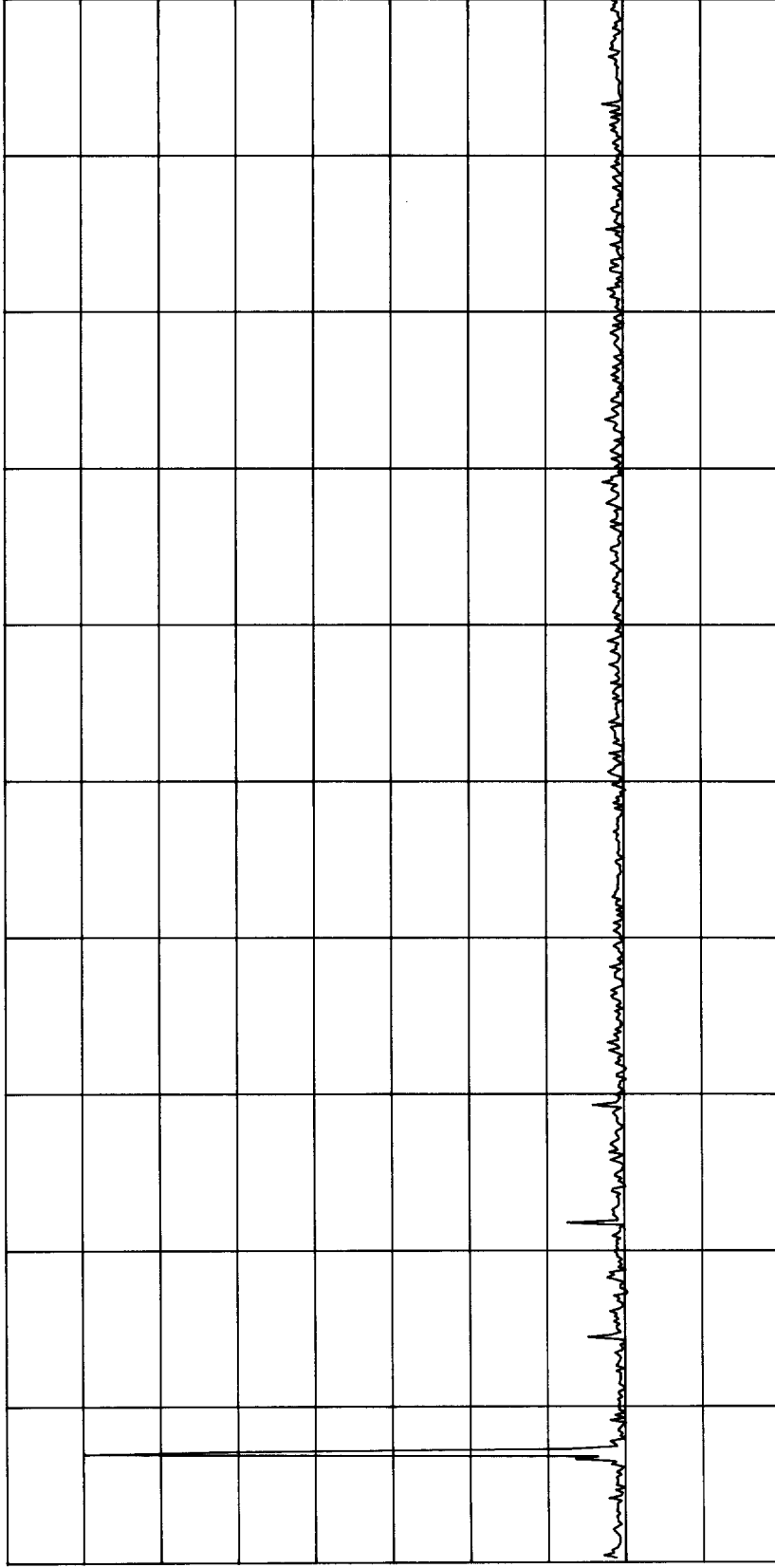

Fig. 2.4.2-10 Spurious emissions at antenna terminal

Frequency: 16525.0kHz
Mode: J3E
Line Voltage: DC 24V

ATTEN 20dB
RL 1.9dBm

10dB/



D

CENTER 150.0MHz VBW 10kHz SPAN 300.0MHz
*RBW 10kHz SWP 7.5sec

Fig. 2.4.2-11 Spurious emissions at antenna terminal

Frequency: 22093.0kHz
Mode: J3E
Line Voltage: DC 24V

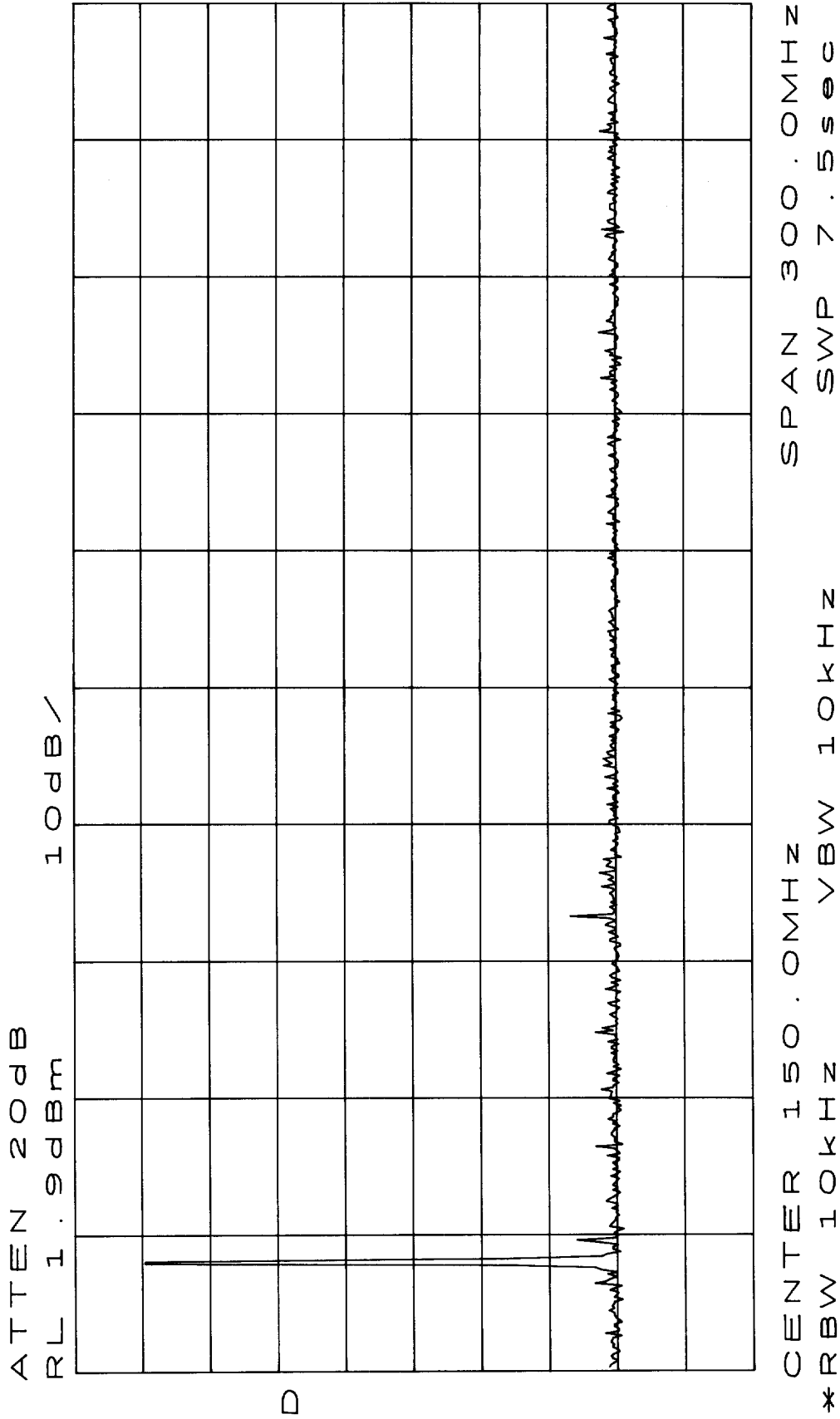

Fig. 2.4.2-12 Spurious emissions at antenna terminal

Frequency: 26175.0kHz
Mode: J3E
Line Voltage: DC 24V

2.5 Field strength of spurious radiation [FCC § 2.1053]

2.5.1 Test procedure

The transmitter was tested for radiated spurious emissions in J3E mode.

During this procedure, the transmitter was tuned to 26.175MHz and the input levels of two tones, 400Hz and 1800Hz, were so adjusted that the two principal frequency components of the radio frequency signal produced were equal in magnitude.

Initially, the radiating frequencies were identified and recorded within a shielded enclosure. The test set up was then re-located to an open field test site.

A nonconductive platform was used to support the transmitter and the dummy load. The power supply leads extended vertically downwards to a power supply located at the bottom of the nonconductive platform. The receiving antenna was located 3 meters from the transmitter during testing.

Two types of antenna were used whichever antenna corresponded to the portion of the spectrum being investigated. The actual magnitude of any unwanted signals was determined with a spectrum analyzer. The level of each spurious signal between 20MHz and 1000MHz was noted.

Field strength was then calculated after adding the necessary cable losses and antenna correction factors. The reference field strength was calculated using the following equation.

$$E = ((49.2) \times (Pt))^{1/2} / D^*$$

Where : E = Field strength (V/Meter)
Pt = Transmitter power (Watts)
D = Distance from transmitter (Meters)

* "Reference Data for Radio Engineers". Fifth Edition, Page 25-7.

2.5.2 Test results

Test results are shown in Table 2.5.2-1.

In all of the following tables, "c" refers to the fundamental carrier frequency of 26.175MHz. The spurious and harmonic radiated emissions are attenuated not less than 60.0dB.

Table 2.5.2-1 Field strength of spurious radiation

Test frequency: 26175.0kHz

Mode: J3E

Tone: 400/1800Hz

Line voltage: DC 24V

Frequency	Field strength (uV/m)	Attenuation (dB)
1c	25.0×10^6	0
2c	2103	-81.5
3c	5861	-72.6
4c	1297	-85.7
5c	2838	-78.9
6c	541	-93.3
7c	940	-88.5
8c	140	-105.0
9c	337	-97.4
10c	30	-118.4
11c	115	-106.7
12c	11	-127.1
13c	49	-114.2
14c	6	-132.4
15c	13	-125.7
16c	2	-141.9
17c	6	-132.4
18c	2	-141.9
19c	2	-141.9
20c	2	-141.9

2.6 Frequency stability
[FCC § 2.1055(a)(1), § 80.209(a)]

2.6.1 Frequency stability with temperature
[FCC § 2.1055(a)(1),(b), § 80.209(a)]

2.6.1.1 Test procedure

The Radio Equipment JSB-196GM was placed in an environmental chamber with control and the equipment was connected as shown in Fig.2.6.1.1-1.

The power supply was set for DC24V and the voltage was monitored during the test. The RF output was fed to 50ohm dummy load and a sample was coupled to the frequency counter.

The equipment was set for the A1A mode. Two test were measured, one at 1619kHz and one at the highest frequency that the transmitter operates, 27499.9kHz.

The temperature chamber was lowed to -30 and the equipment was allowed to stabilize for one(1) hour. The transmitter was keyed and the frequency recorded. The temperature was raised in 10 steps to +50 . The equipment was allowed to stabilize for 60 minutes. The frequency was recorded at each temperature after warm-up time.

2.6.1.2 Test results

Test results are shown in Table 2.6.1.2-1 and Fig. 2.6.1.2-1.

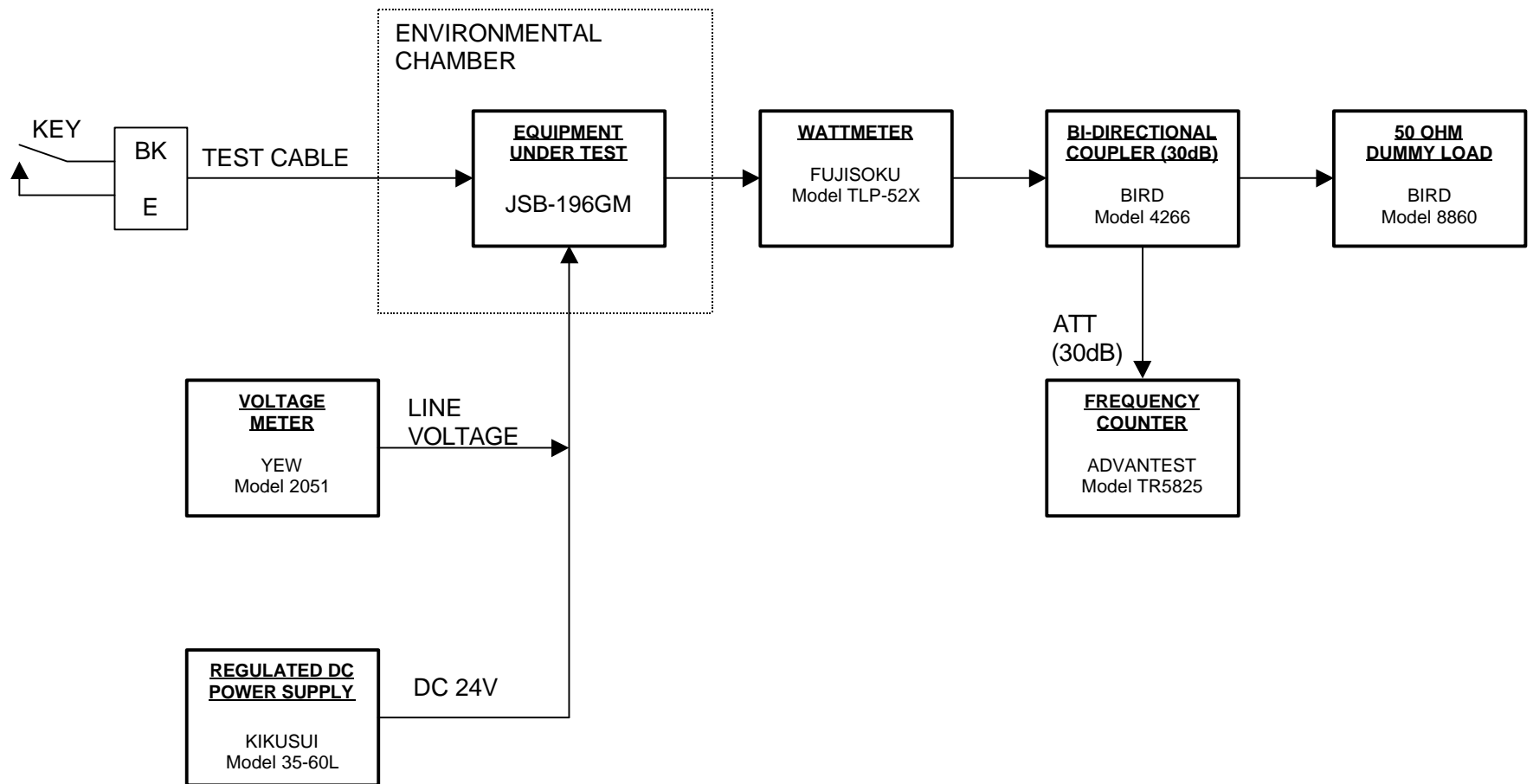

Fig. 2.6.1.1-1 Test set up for Frequency stability with temperature

Table 2.6.1.2-1 Frequency stability with temperature

Test frequency: 1619.0kHz and 27499.9kHz
 Mode: A1A
 Line voltage: DC 24V

Temperature ()	Frequency error (Hz)	
	1619.0kHz	27499.9kHz
-30	-0.2	-1.5
-20	-0.2	-1.4
-10	-0.1	-1.3
0	-0.1	-1.2
10	-0.1	-0.9
20	0.0	-0.8
30	0.0	-0.8
40	+0.1	-0.7
50	+0.1	-0.6

Fig. 2.6.1.2-1 Frequency stability with temperature

Test frequency: 1619.0kHz and 27499.9kHz
 Mode: A1A
 Power source: DC 24V

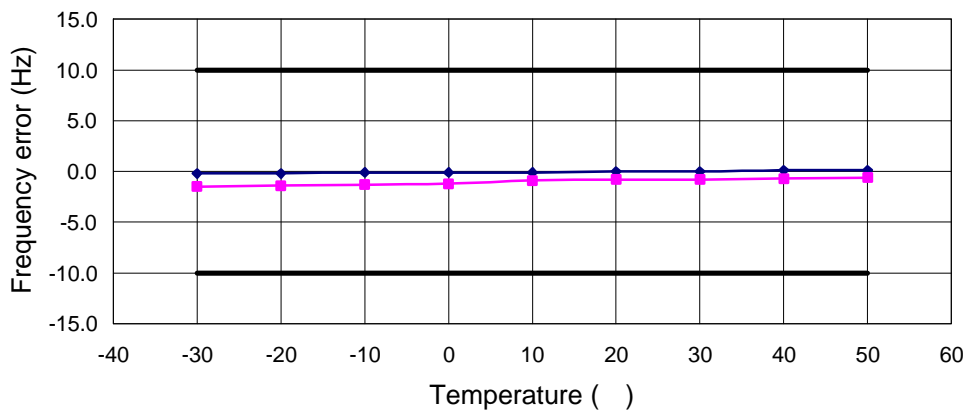

2.6.2 Frequency stability with primary supply voltage [FCC § 2.995(d)(1),(3), § 80.209(a)]

2.6.2.1 Test procedure

The Radio Equipment JSB-196GM was connected as shown in Fig.2.6.2.1-1.

The equipment was set for A1A. The frequency stability with varying line voltage was checked DC power supply condition.

The DC voltage meter was used to measure the primary DC-operation supply voltage.

The primary DC supply voltage was varied from 20.4 to 27.6 volts and the output frequency of the equipment under test in A1A mode was measured at both 1619.0kHz and 27499.9kHz.

2.6.2.2 Test results

Test results are shown in table 2.6.2.2-1 and from Fig. 2.6.2.2-1.

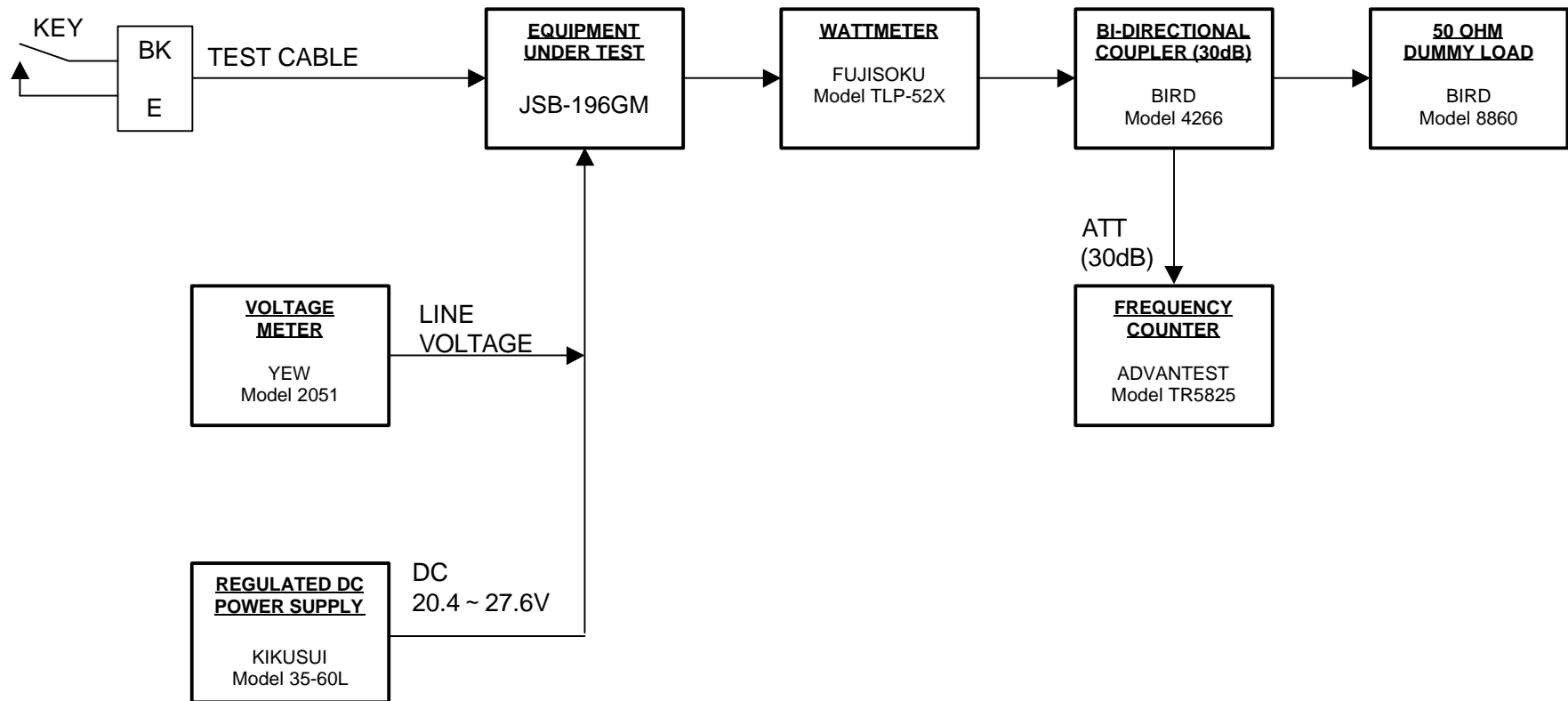

Fig. 2.6.2.1-1 Test set up for Frequency stability with primary supply voltage

Table 2.6.2.2-1 Frequency stability with primary supply voltage

Test frequency: 1619.0kHz and 27499.9kHz
 Mode: A1A
 Line voltage: DC 24V

Voltage variation (%)	Supply voltage (V)	Frequency error (Hz)	
		1619.0kHz	27499.9kHz
-15	20.4	0.0	-0.8
-10	21.6	0.0	-0.8
-5	22.8	0.0	-0.8
0	24.0	0.0	-0.8
5	25.2	0.0	-0.8
10	26.4	0.0	-0.8
15	27.6	0.0	-0.8

Fig. 2.6.2.2-1 Frequency stability with primary supply voltage

Test frequency: 1619.0kHz and 27499.9kHz
 Mode: A1A
 Power source: DC 24V

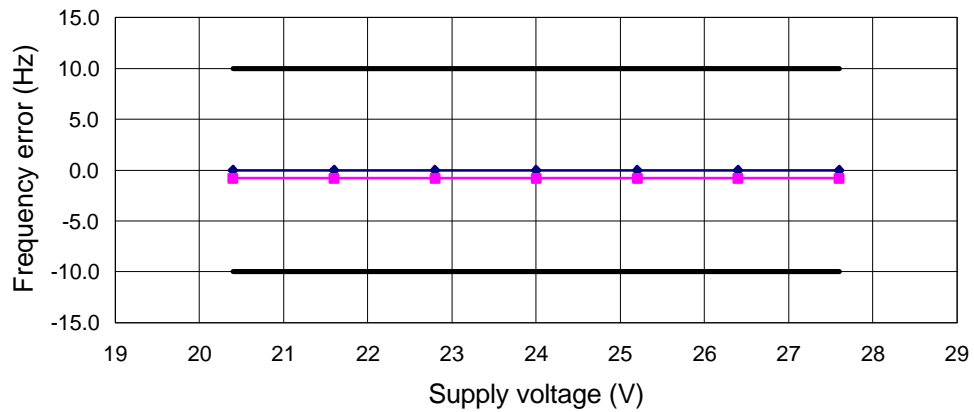

2.6.3 Frequency stability from cold start [FCC § 2.995(c)(1),(2), § 80.209(a)]

The Radio Equipment JSB-196GM uses a DTCXO (non-crystal oven) as a reference generator from which the synthesizer derives all output frequencies. The reference generator is 0.3ppm over a temperature range from –30 to +55 .

Note: DTCXO = Digital Processing Temperature Control Crystal Oscillator

2.6.3.1 Test procedure

The Radio Equipment JSB-196GM was placed in an environmental chamber with control and the equipment was connected as shown in Fig.2.6.3.1-1.

The equipment was measured at –30 to +50 (10 step) and was set for A1A mode.

Two test were measured, one at 1619kHz and one at the highest frequency that the transmitter operates, 27499.9kHz.

The temperature chamber was lowed to –30 and the equipment was allowed to stabilize for one(1) hour with no primary power applied.

The primary power was then applied and the equipment was immediately keyed and the frequency was recorded. The equipment was keyed and frequency recorded at one-minute intervals up to 10 minutes, at two minutes intervals between 10 and 20 minutes, and then, the frequency was recorded every 5 minutes.

The primary power was then removed and the chamber temperature was raised in -20 , and stabilized for 60 minutes after which the measurement was repeated.

2.6.3.2 Test results

Test results are shown from Table 2.6.3.2-1 to Table 2.6.3.2-9 and from Fig. 2.6.3.2-1 to Fig. 2.6.3.2-9.

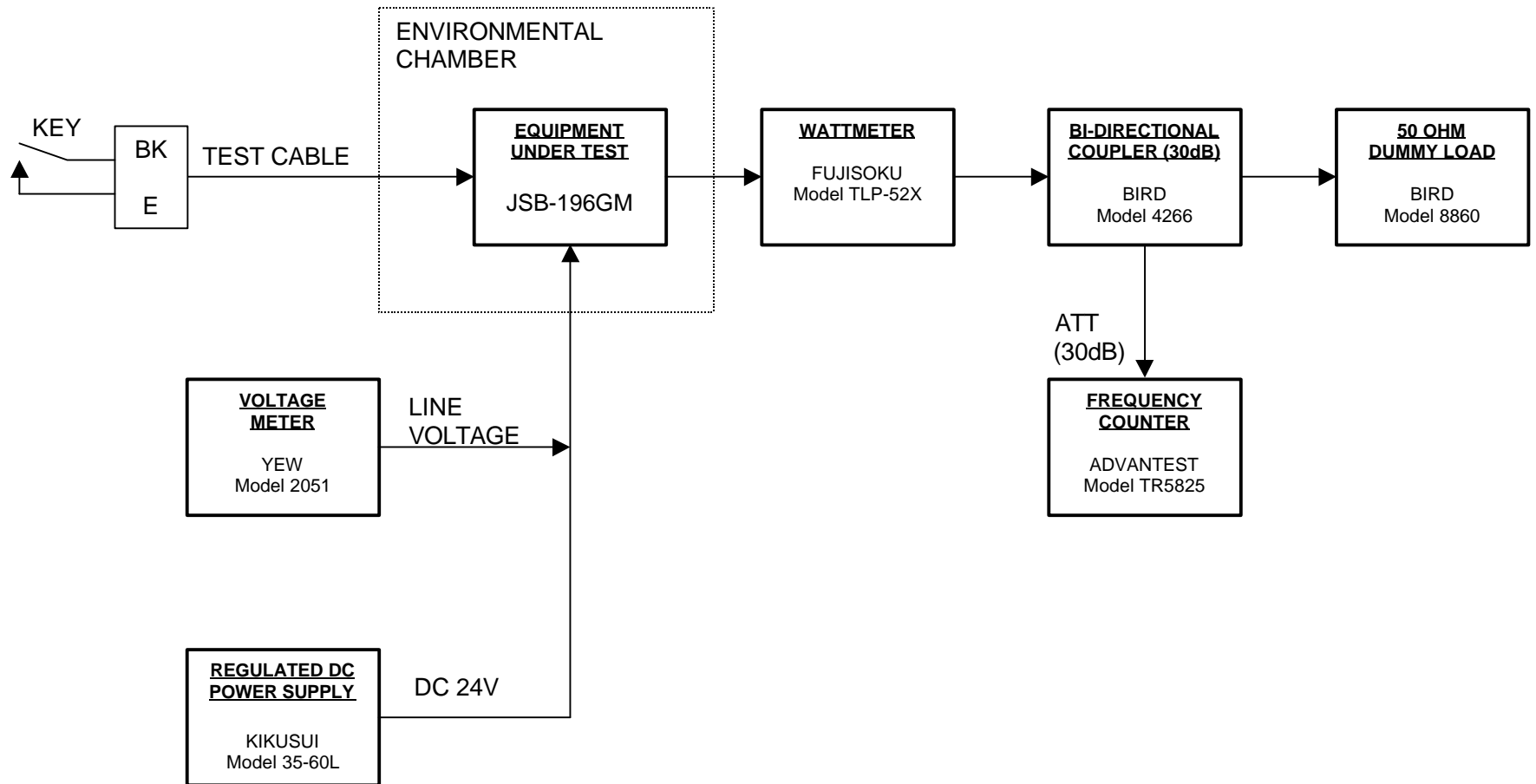

Fig. 2.6.3.1-1 Test set up for Frequency stability from cold start

Table 2.6.3.2-1 Frequency stability from cold start

Test frequency: 1619.0kHz and 27499.9kHz
 Mode: A1A
 Temperature: -30
 Line voltage: DC 24V

Lapse of time (min)	Frequency error (Hz)	
	1619.0kHz	27499.9kHz
0	-0.2	-1.5
1	-0.2	-1.5
2	-0.2	-1.5
3	-0.2	-1.5
4	-0.2	-1.5
5	-0.2	-1.4
6	-0.2	-1.4
7	-0.2	-1.4
8	-0.2	-1.4
9	-0.2	-1.4
10	-0.2	-1.4
12	-0.2	-1.4
14	-0.2	-1.4
16	-0.2	-1.3
18	-0.1	-1.3
20	-0.1	-1.3
25	-0.1	-1.3
30	-0.1	-1.3
35	-0.1	-1.3
40	-0.1	-1.3
45	-0.1	-1.3
50	-0.1	-1.3
55	-0.1	-1.3
60	-0.1	-1.3

Fig. 2.6.3.2-1 Frequency stability from cold start

Temperature: -30
 Test frequency: 1619.0kHz and 27499.9kHz
 Mode: A1A
 Line voltage: DC 24V

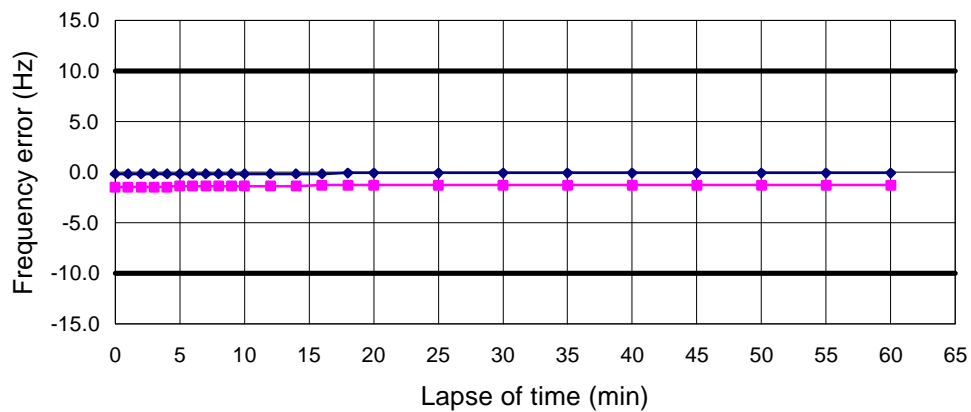

Table 2.6.3.2-2 Frequency stability from cold start

Test frequency: 1619.0kHz and 27499.9kHz
 Mode: A1A
 Temperature: -20
 Line voltage: DC 24V

Lapse of time (min)	Frequency error (Hz)	
	1619.0kHz	27499.9kHz
0	-0.2	-1.4
1	-0.2	-1.4
2	-0.2	-1.4
3	-0.2	-1.4
4	-0.2	-1.4
5	-0.2	-1.4
6	-0.2	-1.4
7	-0.2	-1.3
8	-0.2	-1.3
9	-0.2	-1.3
10	-0.2	-1.3
12	-0.2	-1.3
14	-0.1	-1.3
16	-0.1	-1.2
18	-0.1	-1.2
20	-0.1	-1.2
25	-0.1	-1.2
30	-0.1	-1.2
35	-0.1	-1.2
40	-0.1	-1.2
45	-0.1	-1.2
50	-0.1	-1.2
55	-0.1	-1.2
60	-0.1	-1.2

Fig. 2.6.3.2-2 Frequency stability from cold start

Temperature: -20
 Test frequency: 1619.0kHz and 27499.9kHz
 Mode: A1A
 Line voltage: DC 24V

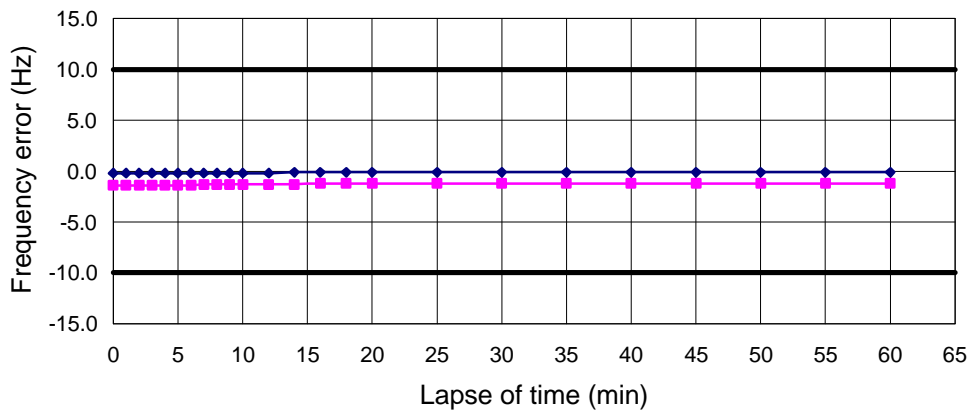

Table 2.6.3.2-3 Frequency stability from cold start

Test frequency: 1619.0kHz and 27499.9kHz
 Mode: A1A
 Temperature: -10
 Line voltage: DC 24V

Lapse of time (min)	Frequency error (Hz)	
	1619.0kHz	27499.9kHz
0	-0.1	-1.3
1	-0.1	-1.3
2	-0.1	-1.3
3	-0.1	-1.3
4	-0.1	-1.3
5	-0.1	-1.3
6	-0.1	-1.3
7	0.0	-1.2
8	0.0	-1.2
9	0.0	-1.2
10	0.0	-1.2
12	-0.1	-1.2
14	-0.1	-1.2
16	-0.1	-1.2
18	0.0	-1.2
20	0.0	-1.2
25	-0.1	-1.2
30	-0.1	-1.2
35	-0.1	-1.2
40	-0.1	-1.2
45	-0.1	-1.2
50	-0.1	-1.2
55	-0.1	-1.2
60	-0.1	-1.2

Fig. 2.6.3.2-3 Frequency stability from cold start

Temperature: -10
 Test frequency: 1619.0kHz and 27499.9kHz
 Mode: A1A
 Line voltage: DC 24V

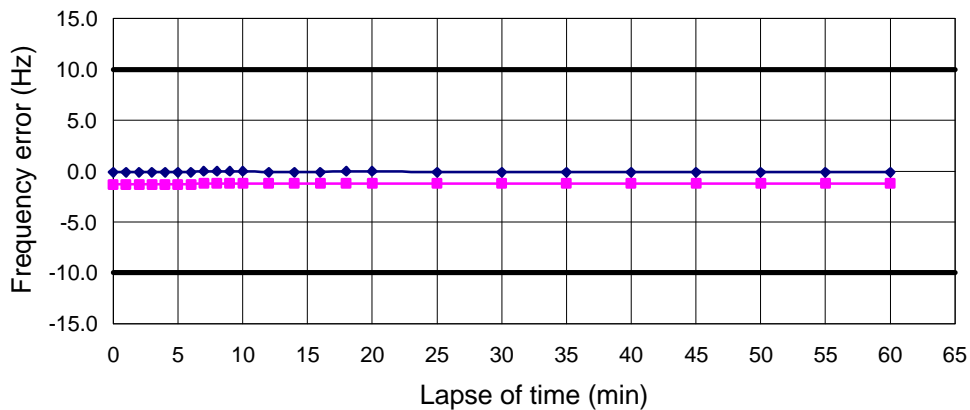

Table 2.6.3.2-4 Frequency stability from cold start

Test frequency: 1619.0kHz and 27499.9kHz
 Mode: A1A
 Temperature: 0
 Line voltage: DC 24V

Lapse of time (min)	Frequency error (Hz)	
	1619.0kHz	27499.9kHz
0	-0.1	-1.2
1	-0.1	-1.2
2	-0.1	-1.2
3	-0.1	-1.2
4	-0.1	-1.2
5	-0.1	-1.2
6	-0.1	-1.2
7	-0.1	-1.2
8	-0.1	-1.2
9	-0.1	-1.2
10	-0.1	-1.2
12	-0.1	-1.1
14	-0.1	-1.2
16	-0.1	-1.2
18	-0.1	-1.2
20	-0.1	-1.1
25	-0.1	-1.1
30	-0.1	-1.1
35	-0.1	-1.1
40	-0.1	-1.1
45	-0.1	-1.1
50	-0.1	-1.1
55	-0.1	-1.1
60	-0.1	-1.1

Fig. 2.6.3.2-4 Frequency stability from cold start

Temperature: 0
 Test frequency: 1619.0kHz and 27499.9kHz
 Mode: A1A
 Line voltage: DC 24V

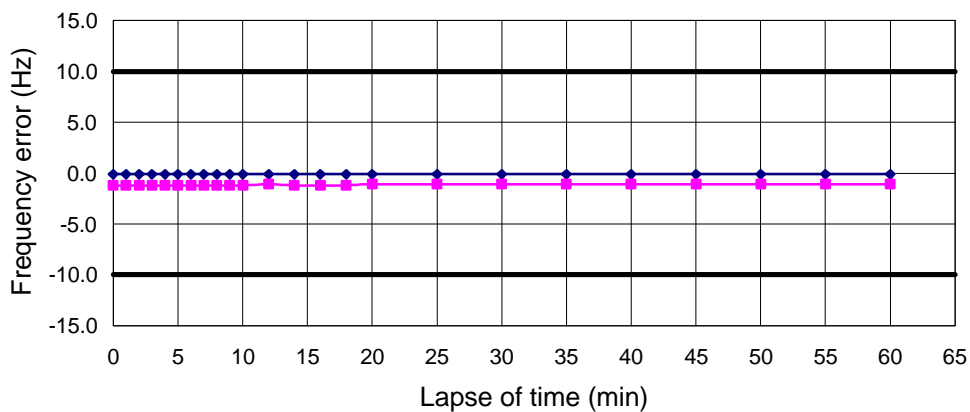

Table 2.6.3.2-5 Frequency stability from cold start

Test frequency: 1619.0kHz and 27499.9kHz
 Mode: A1A
 Temperature: 10
 Line voltage: DC 24V

Lapse of time (min)	Frequency error (Hz)	
	1619.0kHz	27499.9kHz
0	-0.1	-0.9
1	-0.1	-0.9
2	-0.1	-0.9
3	-0.1	-0.9
4	-0.1	-0.9
5	-0.1	-0.9
6	-0.1	-0.9
7	-0.1	-0.9
8	-0.1	-0.9
9	-0.1	-0.9
10	-0.1	-0.8
12	-0.1	-0.8
14	-0.1	-0.8
16	-0.1	-0.8
18	-0.1	-0.8
20	-0.1	-0.8
25	-0.1	-0.8
30	-0.1	-0.8
35	0.0	-0.8
40	0.0	-0.8
45	0.0	-0.8
50	0.0	-0.8
55	0.0	-0.8
60	0.0	-0.8

Fig. 2.6.3.2-5 Frequency stability from cold start

Temperature: 10
 Test frequency: 1619.0kHz and 27499.9kHz
 Mode: A1A
 Line voltage: DC 24V

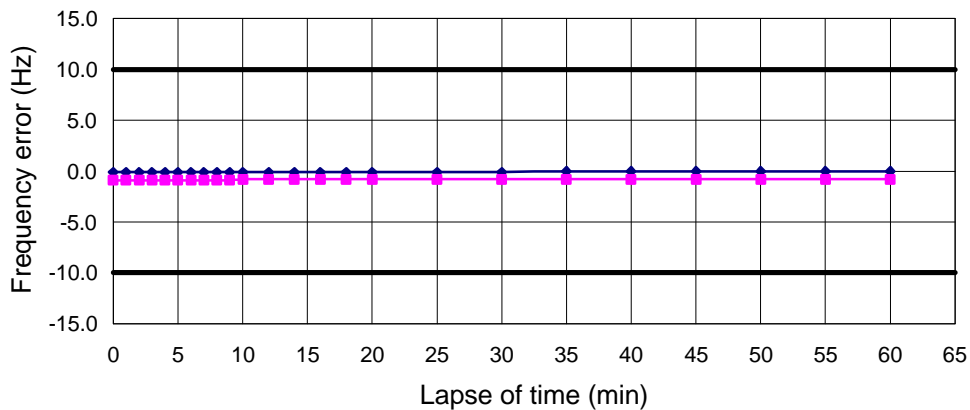

Table 2.6.3.2-6 Frequency stability from cold start

Test frequency: 1619.0kHz and 27499.9kHz
 Mode: A1A
 Temperature: 20
 Line voltage: DC 24V

Lapse of time (min)	Frequency error (Hz)	
	1619.0kHz	27499.9kHz
0	0.0	-0.8
1	0.0	-0.8
2	0.0	-0.8
3	0.0	-0.8
4	0.0	-0.8
5	0.0	-0.8
6	0.0	-0.8
7	0.0	-0.8
8	0.0	-0.8
9	0.0	-0.8
10	0.0	-0.8
12	0.0	-0.8
14	0.0	-0.8
16	0.0	-0.7
18	0.0	-0.7
20	+0.1	-0.7
25	+0.1	-0.7
30	+0.1	-0.7
35	+0.1	-0.7
40	+0.1	-0.7
45	+0.1	-0.7
50	+0.1	-0.7
55	+0.1	-0.7
60	+0.1	-0.7

Fig. 2.6.3.2-6 Frequency stability from cold start

Temperature: 20
 Test frequency: 1619.0kHz and 27499.9kHz
 Mode: A1A
 Line voltage: DC 24V

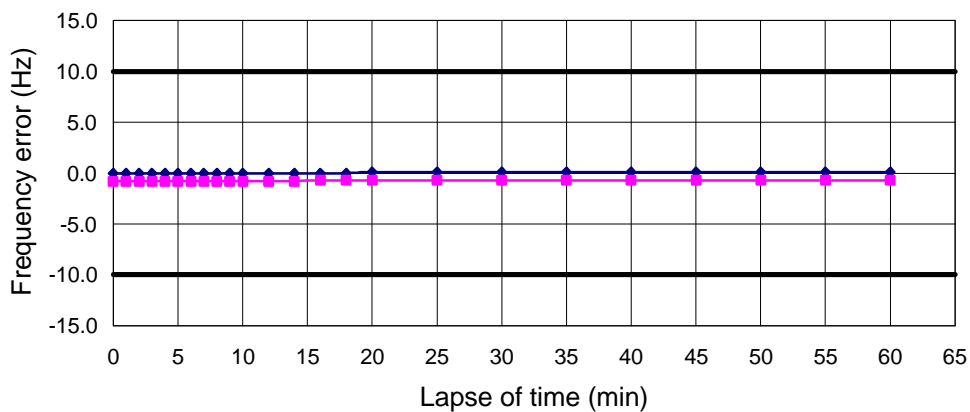

Table 2.6.3.2-7 Frequency stability from cold start

Test frequency: 1619.0kHz and 27499.9kHz
 Mode: A1A
 Temperature: 30
 Line voltage: DC 24V

Lapse of time (min)	Frequency error (Hz)	
	1619.0kHz	27499.9kHz
0	0.0	-0.8
1	0.0	-0.8
2	0.0	-0.8
3	0.0	-0.8
4	0.0	-0.8
5	0.0	-0.8
6	0.0	-0.7
7	0.0	-0.7
8	0.0	-0.7
9	0.0	-0.7
10	0.0	-0.7
12	0.0	-0.7
14	0.0	-0.7
16	0.0	-0.7
18	0.0	-0.7
20	0.0	-0.7
25	0.0	-0.7
30	0.0	-0.6
35	0.0	-0.6
40	+0.1	-0.6
45	+0.1	-0.6
50	+0.1	-0.6
55	+0.1	-0.6
60	+0.1	-0.6

Fig. 2.6.3.2-7 Frequency stability from cold start

Temperature: 30
 Test frequency: 1619.0kHz and 27499.9kHz
 Mode: A1A
 Line voltage: DC 24V

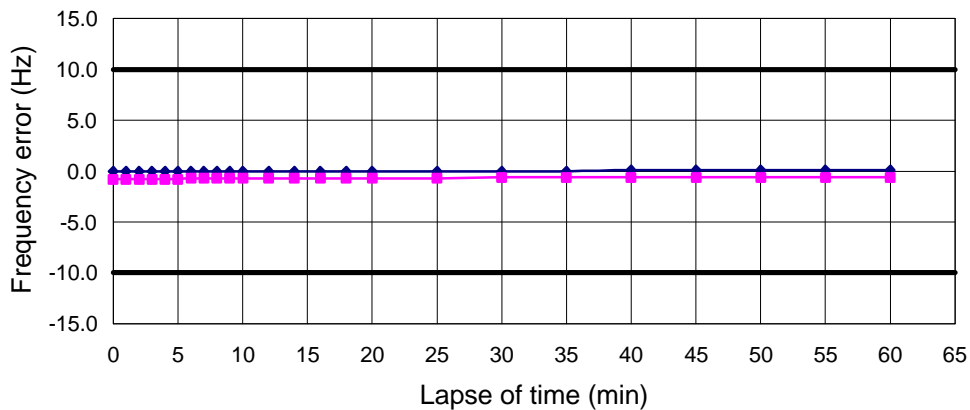

Table 2.6.3.2-8 Frequency stability from cold start

Test frequency: 1619.0kHz and 27499.9kHz
 Mode: A1A
 Temperature: 40
 Line voltage: DC 24V

Lapse of time (min)	Frequency error (Hz)	
	1619.0kHz	27499.9kHz
0	+0.1	-0.7
1	+0.1	-0.7
2	+0.1	-0.7
3	+0.1	-0.7
4	+0.1	-0.7
5	+0.1	-0.7
6	+0.1	-0.7
7	+0.1	-0.7
8	+0.1	-0.7
9	+0.1	-0.7
10	+0.1	-0.7
12	+0.1	-0.7
14	+0.1	-0.7
16	+0.1	-0.7
18	+0.1	-0.7
20	+0.1	-0.6
25	+0.1	-0.6
30	+0.1	-0.6
35	+0.1	-0.6
40	+0.1	-0.6
45	+0.1	-0.6
50	+0.1	-0.6
55	+0.1	-0.6
60	+0.1	-0.6

Fig. 2.6.3.2-8 Frequency stability from cold start

Temperature: 40
 Test frequency: 1619.0kHz and 27499.9kHz
 Mode: A1A
 Line voltage: DC 24V

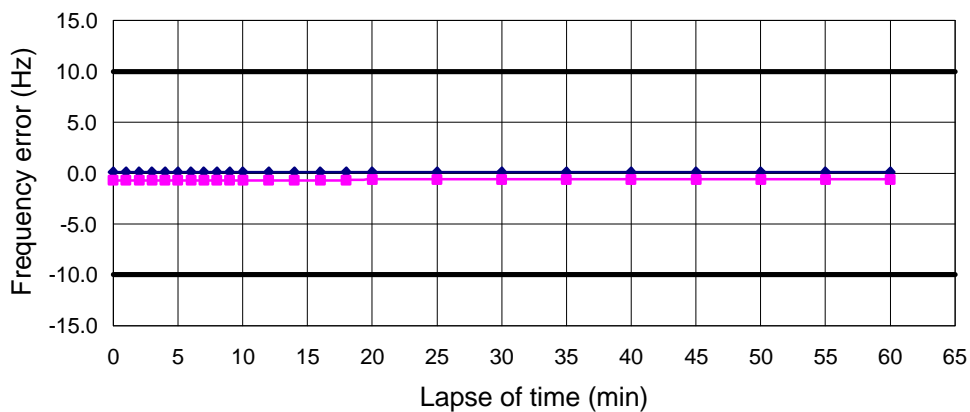

Table 2.6.3.2-9 Frequency stability from cold start

Test frequency: 1619.0kHz and 27499.9kHz
 Mode: A1A
 Temperature: 50
 Line voltage: DC 24V

Lapse of time (min)	Frequency error (Hz)	
	1619.0kHz	27499.9kHz
0	+0.1	-0.6
1	+0.1	-0.6
2	+0.1	-0.5
3	+0.1	-0.6
4	+0.1	-0.6
5	+0.1	-0.6
6	+0.1	-0.6
7	+0.1	-0.6
8	+0.1	-0.6
9	+0.1	-0.6
10	+0.1	-0.6
12	+0.1	-0.6
14	+0.1	-0.5
16	+0.1	-0.5
18	+0.2	-0.5
20	+0.2	-0.5
25	+0.2	-0.5
30	+0.2	-0.5
35	+0.2	-0.4
40	+0.2	-0.4
45	+0.2	-0.4
50	+0.2	-0.4
55	+0.2	-0.4
60	+0.2	-0.4

Fig. 2.6.3.2-9 Frequency stability from cold start

Temperature: 50
 Test frequency: 1619.0kHz and 27499.9kHz
 Mode: A1A
 Line voltage: DC 24V

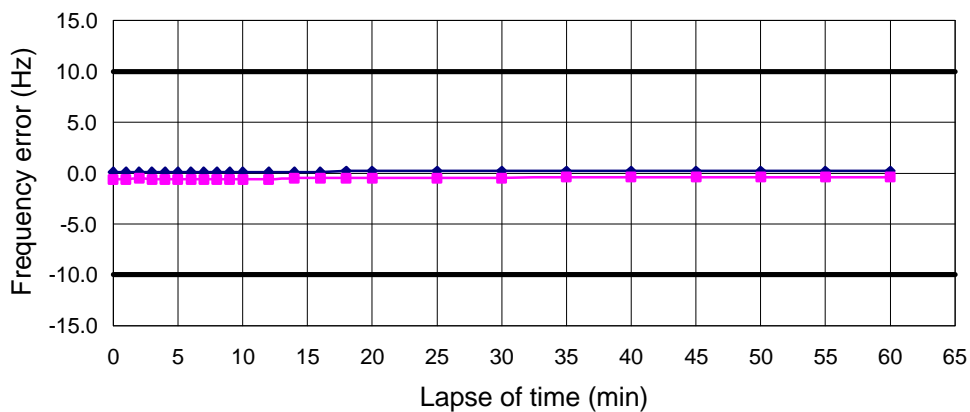

2.7 Interference
[FCC § 15.207, § 15.209]

2.7.1 Description of equipment

The equipment under test is JSB-196GM which consists of DSC Terminal NCT-196, Antenna tuner NFC-196, and DC-DC converter NBG-300.

2.7.2 Set up of testing

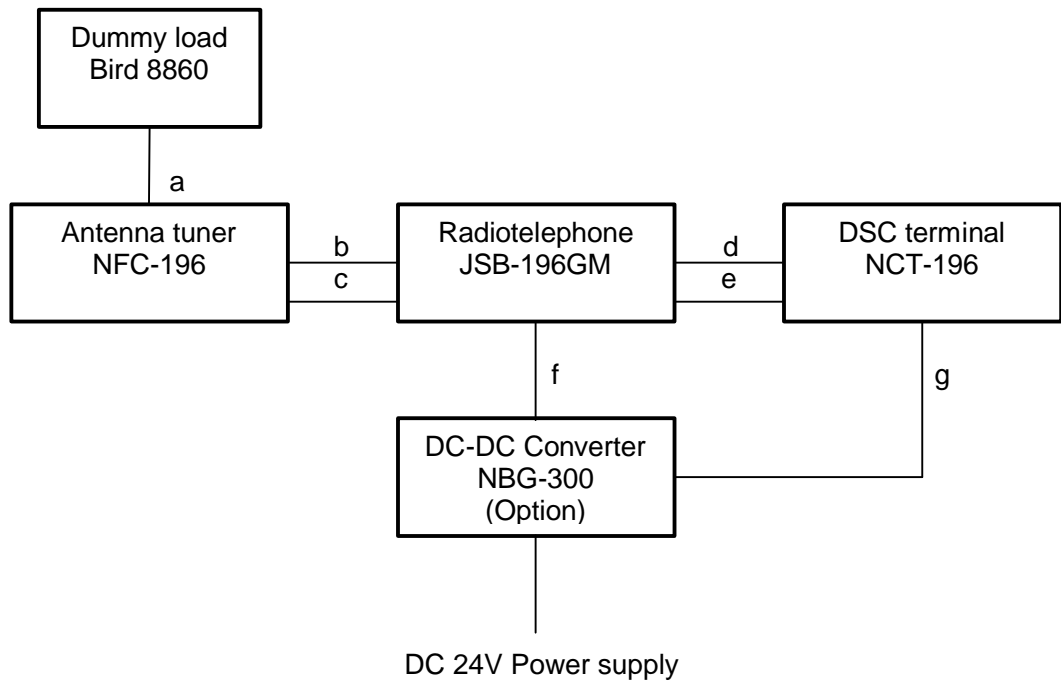

- a. RF coaxial cable
- b. Control cable
- c. RF coaxial cable
- d. Control cable
- e. Audio cable
- f. Power cable
- g. Power cable

2.7.3 Test procedure

The equipment was tested on the marine band at three frequencies, 2187.5kHz, 12577.0kHz and 26400.0kHz with J3E mode.

(1) Conducted interference

The line-impedance stabilization network (LISN) was connected between the equipment under test JSB-196GM and primary power supply.

The actual magnitude of any unwanted signals was measured with the spectrum analyzer and the test receiver. The level of each unwanted signal between 450kHz and 30MHz was noted. Conducted interference was calculated after adding the necessary cable losses and LISN factors.

(2) Radiated interference

The equipment was placed on the nonconductive platform (turntable) of EMI shielded room. The receiving antenna was located 3 meters away from the transmitter during testing. In order to investigate the maximum magnitude of any spurious signals, the turntable was rotated in every direction, the receiving antenna was moved up and down and the direction was changed into horizontal and vertical plane. The level of each spurious signal was measured with the spectrum analyzer between 9kHz and 2GHz and was calculated after adding the necessary cable losses and antenna correction factors.

*Test Place

CHEMITOX EMC RESERCH, INC.

14979, Egusa, Sudama-cho, Kitakoma-gun, Yamanashi 408-01 JAPAN

UK Accreditation NO.2126. M10, EN45001 and ISO/IEC Guide 25.

NIST NVLAP Accredited Laboratory for FCC Part 15/ CISPR 22.

2.7.4 Test results

Test results are shown from Table 2.7.4-1 to Table 2.7.4-6 and from Fig. 2.7.4-1 to Fig. 2.7.4-6.

Table 2.7.4-1 Conducted interference

Test frequency: 2187.5kHz
 Mode: J3E
 Line voltage: DC 24V

Frequency (MHz)	Reading QP (dBuV)	LISN factor (dB)	Emission QP (dBuV)
1.525	33.1	0.2	33.3
2.684	24.9	0.3	25.2
11.224	32.2	0.6	32.8
11.543	30.1	0.6	30.7
12.184	26.9	0.6	27.5

Emission QP level = Reading QP level + LISN factor

Table 2.7.4-2 Conducted interference

Test frequency: 12577.0kHz
 Mode: J3E
 Line voltage: DC 24V

Frequency (MHz)	Reading QP (dBuV)	LISN factor (dB)	Emission QP (dBuV)
1.522	35.7	0.2	35.9
2.682	28.0	0.3	28.3
11.191	32.5	0.6	33.1
11.510	30.8	0.6	31.4
12.149	26.8	0.6	27.4

Emission QP level = Reading QP level + LISN factor

Table 2.7.4-3 Conducted interference

Test frequency: 26400.0kHz
 Mode: J3E
 Line voltage: DC 24V

Frequency (MHz)	Reading QP (dBuV)	LISN factor (dB)	Emission QP (dBuV)
1.522	36.1	0.2	36.3
2.678	27.3	0.3	27.6
11.188	31.7	0.6	32.3
11.507	30.1	0.6	30.7
12.146	26.7	0.6	27.3

Emission QP level = Reading QP level + LISN factor

Fig. 2.7.4-1 Conducted interference

Test frequency: 2187.5kHz
Mode: J3E

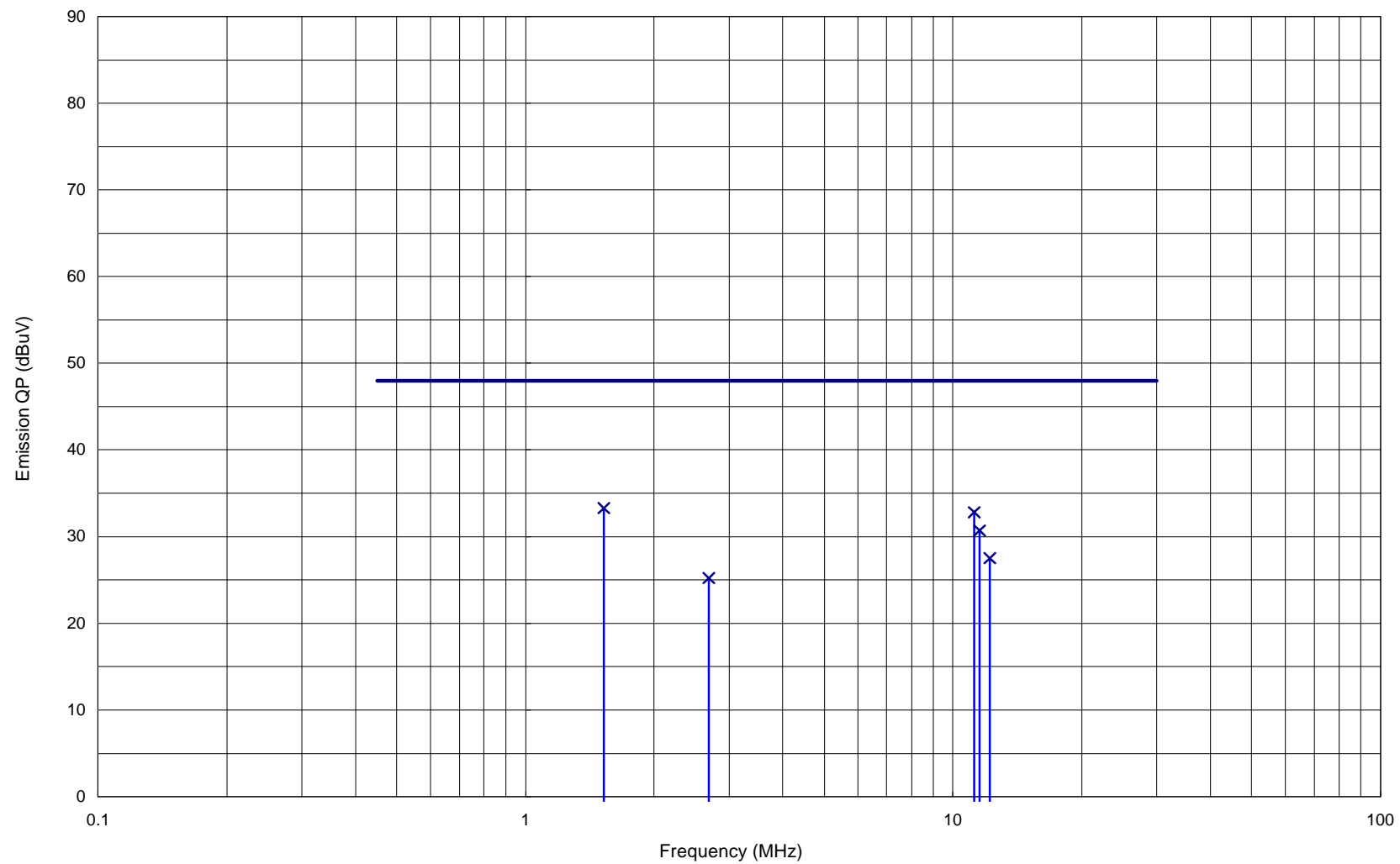

Fig. 2.7.4-2 Conducted interference

Test frequency: 12577.0kHz

Mode: J3E

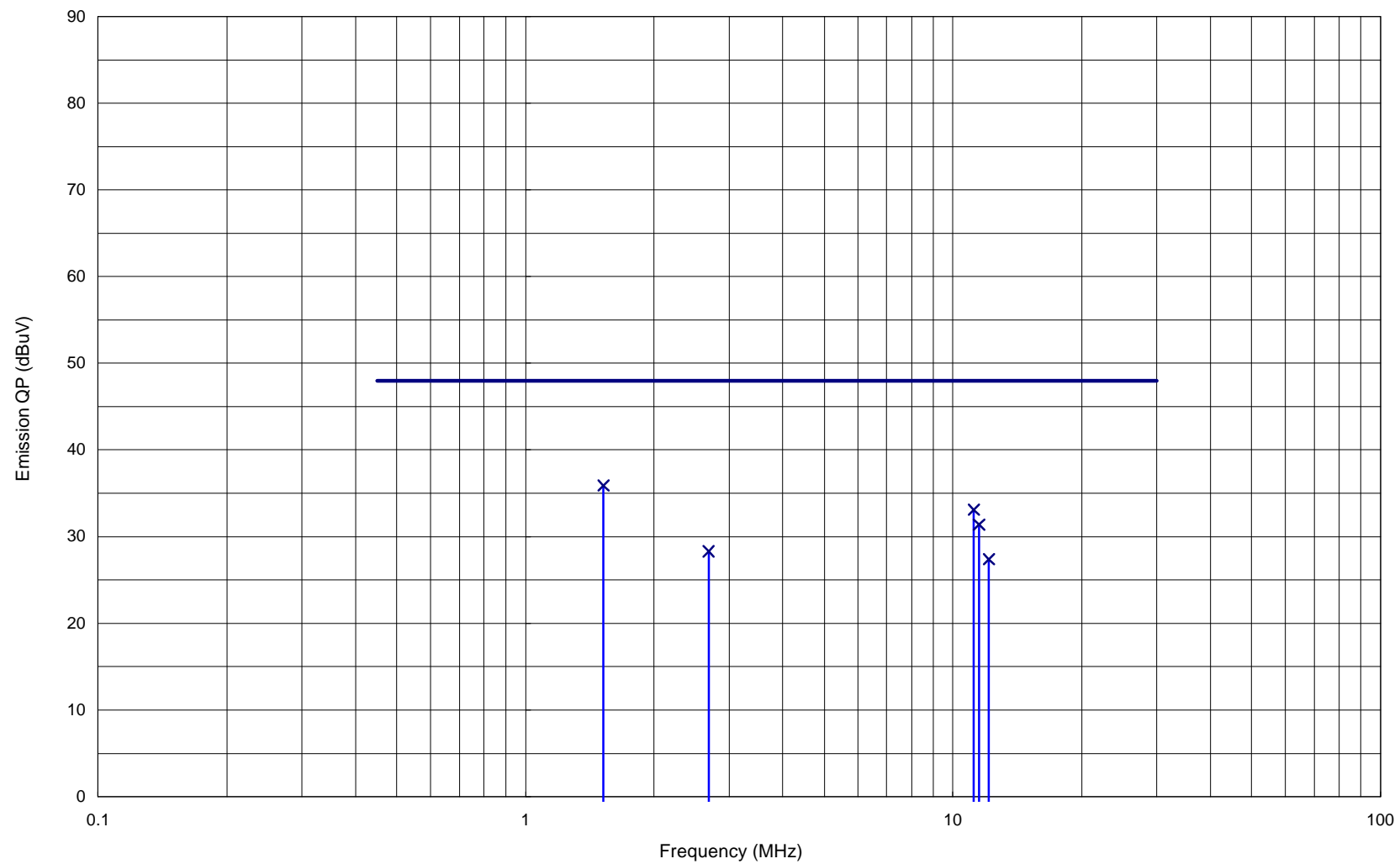

Fig. 2.7.4-3 Conducted interference

Test frequency: 26400.0kHz

Mode: J3E

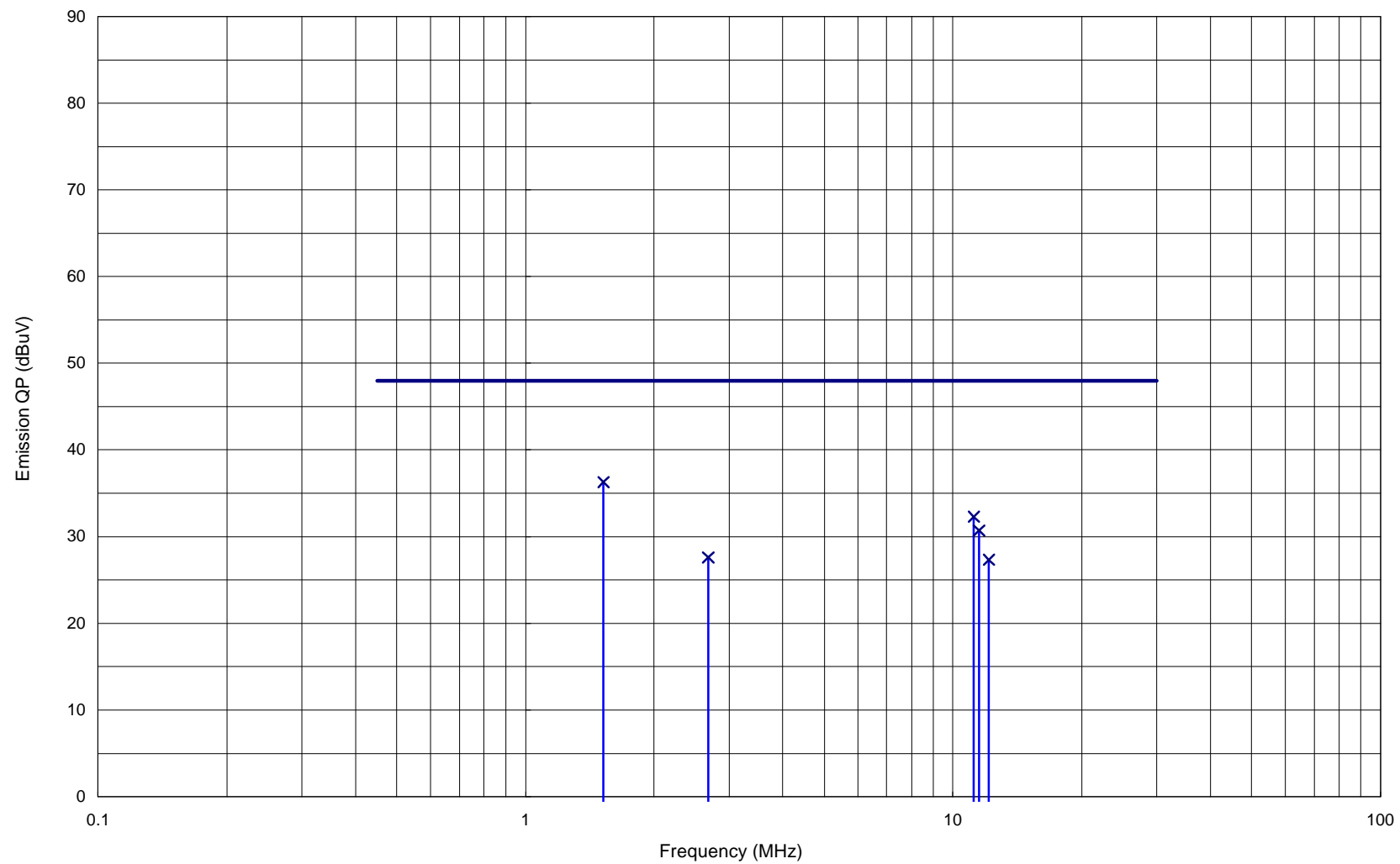

Table 2.7.4-4 Radiated interference

Test frequency: 2187.5kHz
 Mode: J3E
 Line voltage: DC 24V

Frequency (MHz)	Reading (dBUV)		Calibration Factor (dB)	Emission Level (dBUV/m)
	Horizontal Plane	Vertical Plane		
0.150	----	21.6	+20.3	41.9
0.202	----	21.3	+20.3	41.5
0.826	----	13.0	+20.1	33.1
1.279	----	7.0	+20.1	27.1
1.920	----	9.9	+20.1	30.1
2.080	----	11.3	+20.2	31.5
94.57	----	42.8	-11.9	30.9
140.00	35.4	37.2	-6.2	31.0
145.29	44.5	42.8	-6.1	38.4
156.67	25.4	22.8	-6.7	18.7
159.74	24.7	23.0	-6.5	18.2
160.00	20.6	20.4	-6.5	14.1
165.00	20.5	22.9	-6.3	16.9
210.95	----	35.8	-7.8	28.0
217.93	36.0	----	-8.4	27.6
307.20	36.2	----	-4.6	31.6
325.63	37.2	----	-4.8	32.4
430.08	35.0	38.1	-0.9	37.2
757.76	----	31.0	+6.1	37.1

Emission level = Reading level + Calibration factor

Calibration factor = Antenna factor + Cable loss – Amplifier gain

Fig. 2.7.4-4 Radiated interference

Test frequency: 2187.5kHz
Mode: J3E

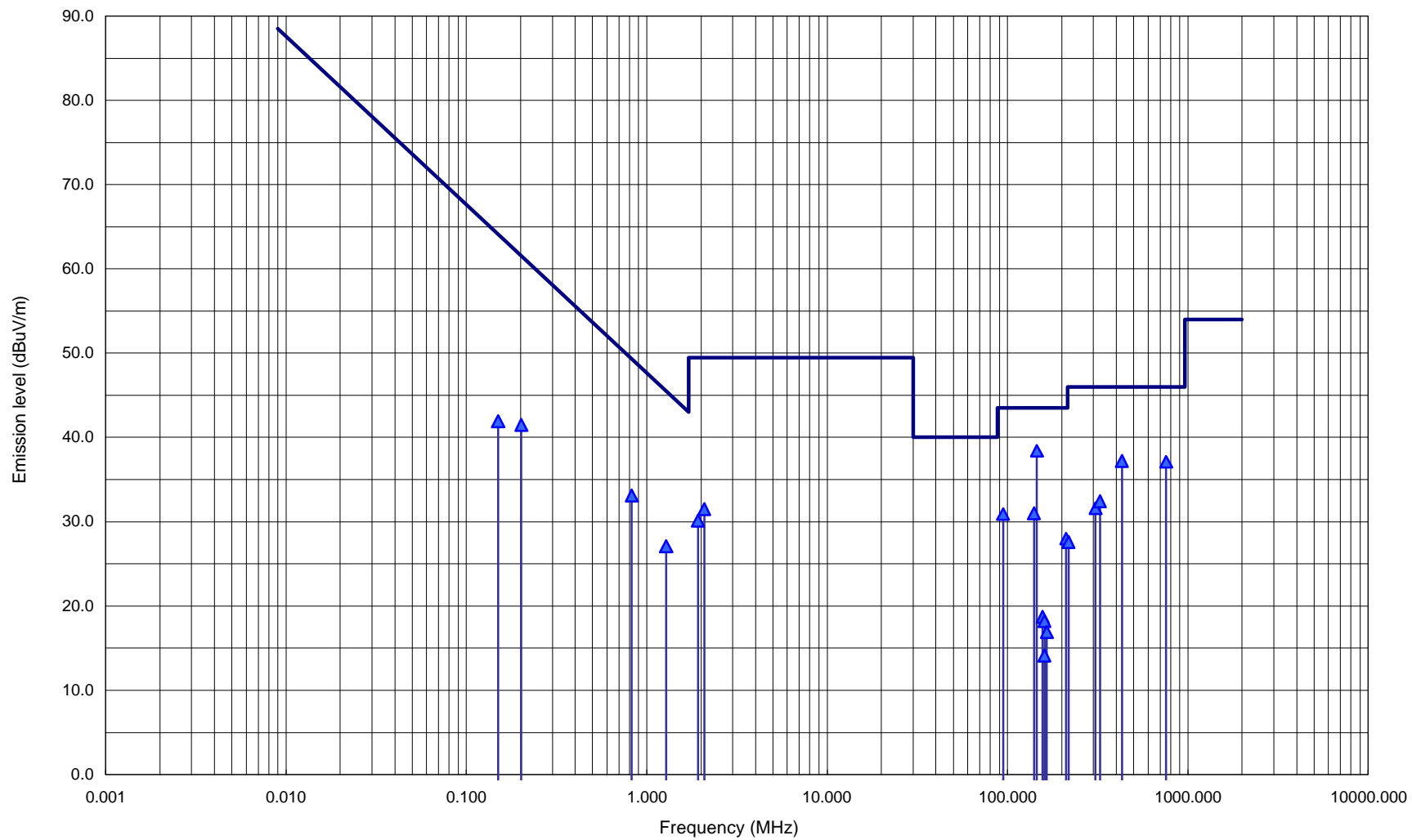

Table 2.7.4-5 Radiated interference

Test frequency: 12577.0kHz

Mode: J3E

Line voltage: DC 24V

Frequency (MHz)	Reading (dBUV)		Calibration Factor (dB)	Emission Level (dBUV/m)
	Horizontal Plane	Vertical Plane		
0.150	----	23.3	+20.3	43.6
0.203	----	20.9	+20.3	41.1
0.826	----	13.3	+20.1	33.4
1.280	----	8.5	+20.1	28.6
1.920	----	10.0	+20.1	30.2
2.080	----	11.6	+20.2	31.8
97.36	----	44.1	-11.2	32.9
140.00	----	35.3	-6.2	29.1
156.67	25.3	23.2	-6.7	18.6
159.74	23.9	22.8	-6.5	17.4
160.00	20.2	19.8	-6.5	13.7
165.00	20.1	23.1	-6.0	17.1
166.04	45.2	45.9	-6.3	39.6
210.95	----	37.3	-7.8	29.5
249.05	44.7	38.1	-7.0	37.7
319.49	38.6	----	-4.7	33.9
405.50	35.2	----	-1.4	33.8
430.08	----	39.0	-0.9	38.1
698.36	----	30.5	+5.0	35.5
704.52	33.7	----	+5.1	38.8

Emission level = Reading level + Calibration factor

Calibration factor = Antenna factor + Cable loss – Amplifier gain

Fig. 2.7.4-5 Radiated interference

Test frequency: 12577.0kHz
Mode: J3E

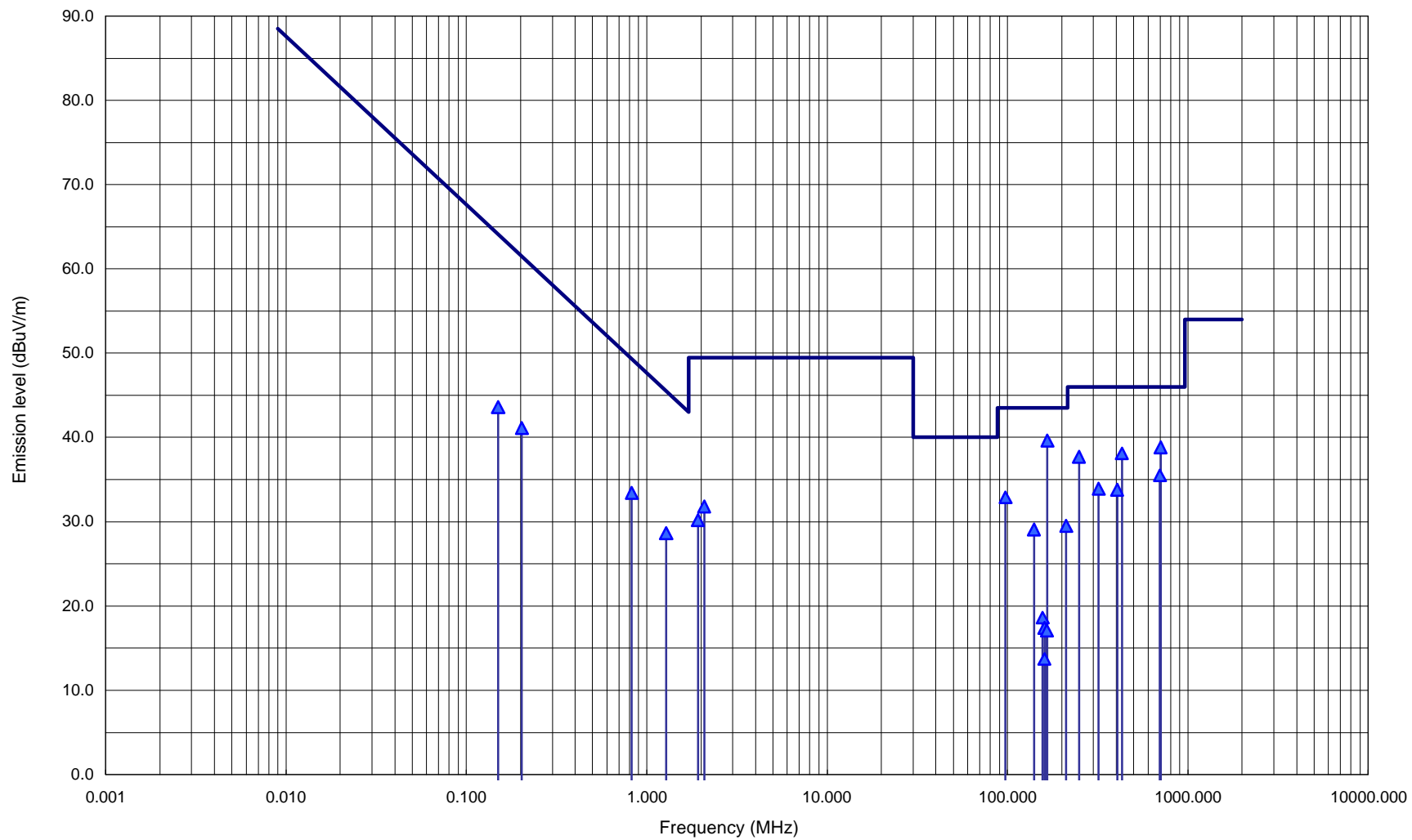

Table 2.7.4-6 Radiated interference

Test frequency: 26400.0kHz
 Mode: J3E
 Line voltage: DC 24V

Frequency (MHz)	Reading (dBUV)		Calibration Factor (dB)	Emission Level (dBUV/m)
	Horizontal Plane	Vertical Plane		
0.150	----	22.3	+20.3	42.6
0.203	----	21.7	+20.3	42.0
0.826	----	12.9	+20.1	33.0
1.277	----	8.0	+20.1	28.1
1.928	----	9.7	+20.1	29.8
2.081	----	11.4	+20.2	31.6
96.39	----	43.0	-11.5	31.5
140.00	----	35.2	-6.2	29.0
156.67	24.8	22.7	-6.7	18.1
159.74	24.0	22.0	-6.5	17.5
160.00	20.3	20.0	-6.5	13.8
165.00	19.8	23.2	-6.0	17.2
193.71	35.4	----	-6.7	28.7
210.95	----	37.4	-7.8	29.6
217.09	35.3	----	-8.4	26.9
319.49	38.0	----	-4.7	33.3
405.50	35.2	----	-1.4	33.8
430.08	----	37.7	-0.9	36.8
698.36	----	28.7	+5.0	33.7
704.52	32.9	----	+5.1	38.0

Emission level = Reading level + Calibration factor

Calibration factor = Antenna factor + Cable loss – Amplifier gain

Fig. 2.7.4-6 Radiated interference

Test frequency: 26400.0kHz

Mode: J3E

