

TEST DATA OF JMA-3811

Type	JMA-3811	Ser. No. LE59220
Scanner Unit	NKE-1055	Ser. No. LE39220
Display Unit	NCD-3860	Ser. No. LE29220
Ship's Main	DC24V	

Date MAR. 20. 1998

Section Chief

M. Sudoh

Inspector

K. Yuasa

TABLE OF CONTENTS

<u>RULE</u>	<u>DESCRIPTION</u>	<u>PAGE</u>
2.983	LIST OF GENERAL INFORMATION REQUIRED	2
	SUMMARY OF CALCULATIONS	3
	TEST INSTRUMENTATION LIST	4
2.985(a)	R. F. POWER OUTPUT	9
80.215		
2.987(b)	MODULATION CHARACTERISTICS - MODULATION LIMITING	11
2.989(c)	OCCUPIED BANDWIDTH	12
80.205, 80.241		
	CALCULATION OF PEAK POWER	10
	PULSE WIDTH, PULSE REPETITION FREQUENCY SHORT PULSE	13
	PULSE WIDTH, PULSE REPETITION FREQUENCY MEDIUM PULSE	14
	PULSE WIDTH, PULSE REPETITION FREQUENCY LONG PULSE	15
2.991	SPURIOUS EMISSIONS AT ANTENNA TERMINALS	16
80.211		
2.993(a)	FIELD STRENGTH OF SPURIOUS RADIATION	66
2.995(a)	FREQUENCY STABILITY - TEMPERATURE VARIATION	67
80.209		
2.995(d)	FREQUENCY STABILITY - VOLTAGE VARIATION	67
80.217	RECEIVER RADIATION - ANTENNA CONDUCTED	68
		69

LIST OF GENERAL INFORMATION REQUIRED FOR TYPE ACCEPTANCE

IN ACCORDANCE WITH FCC RULES AND REGULATIONS,
VOLUME II, PART 2 AND TO
80

Sub-Part

2.983(a): NAME AND ADDRESS OF MANUFACTURE

Japan Radio Co., Ltd.
Akasaka Twin Tower Main Bldg
FL/5&6 17-22 Akasaka 2-chome
Minato-ku Tokyo 107 JAPAN

VENDOR:

Japan Radio Co., Ltd.
1011 SW KLUICKITAT WAY BLDG.B SUITE100
SEATTLE, WA. 98134

2.983(b): FCC ID: CKEJMA3811

MODEL NO: JMA-3811

2.983(c): QUANTITY PRODUCTION PLANNED.

2.983(d): TECHNICAL DESCRIPTION: SEE ATTACHED EXHIBITS

(1): TYPE OF EMISSION: 5M3PON

(2): FREQUENCY RANGE, GHz: 9.3 to 9.5

(3): POWER RATING, kW PEAK: 10kw
SWITCHABLE _____ ADJUSTABLE _____ N/A x

(4): MAXIMUM POWER CONSUMPTION, Watts: 120 WAVE.

NAME OF TEST: SUMMARY OF CALCULATIONS
PARAGRAPH:
GUIDE:
TEST CONDITIONS: STANDARD TEMPERATURE & HUMIDITY
TEST EQUIPMENT: AS PER ATTACHED PAGE

PROCEDURE

Tests and calculations for the indicated parameters were conducted and made as follows:

1. The average power, pulse widths, pulse rise and decay times, and the interval between successive output pulses were measured.
2. The pulse repetition frequency (P.R.F.) was then calculated from the reciprocal of the interval.
3. The duty cycle was calculated from the product of the P. F.R. and the pulse width.
4. The average power was corrected for attenuation.
5. The peak power was calculated by dividing the average power by the duty cycle.
6. The spurious and harmonic radiation characteristics, the occupied bandwidth and the receiver radiation were measured.
7. MEASUREMENT RESULTS: ATTACHED

THE APPLICANT HAS BEEN CAUTIONED AS TO THE FOLLOWING:

3811 INFORMATION TO USER.

The users manual or instruction manual for an intentional radiator shall caution the user that changes or modifications not expressly approved by the party responsible for compliance could void the user's authority to operate the equipment.

15.27(a) SPECIAL ACCESSORIES.

Equipment marketed to a consumer must be capable of complying with the necessary regulations in the configuration in which the equipment is marketed. Where special accessories, such as shielded cables and/or special connectors are required to enable an unintentional or intentional radiator to comply with the emission limits in this part, the equipment must be marketed with, i.e. shipped and sold with, those special accessories. However, in lieu of shipping or packaging the special accessories with the unintentional or intentional radiator, the responsible party may employ other methods of ensuring that the special accessories are provided to the consumer, without additional charge.

Information detailing any alternative method used to supply the special accessories for a grant of equipment authorization or retained in the verification records, as appropriate. The party responsible for the equipment, as detailed in § 2.909 of this chapter, shall ensure that these special accessories are provided with the equipment. The instruction manual for such devices shall include appropriate instructions on the first page of text concerned with the installation of the device that these special accessories must be used with the device. It is the responsibility of the user to use the needed special accessories supplied with the equipment.

Sub-part
2.983te):

TEST AND MEASUREMENT DATA

All tests and measurement data shown were performed in accordance with FCC Rules and Regulations, Volume II; Part 2, Sub-part J, Sections 2.981, 2.983, 2.985, 2.987, 2.989, 2.991, 2.993, 2.995, 2.997, 2.999 and the following individual Parts:

- 21 - Domestic Public Fixed Radio Services
- 22 - Public Mobile Services
- 22 Subpart H - Cellular Radiotelephone Service
- 22.901(d) - Alternative technologies and auxiliary services
- 23 - International Fixed Public Radio communication services
- 24 - Personal Communications Services
- 74 Subpart H - Low Power Auxiliary Stations
- X 80 - Stations in the Maritime Services
- 80 Subpart E - General Technical Standards
- 80 Subpart F - Equipment Authorization for Compulsory Ships
- 80 Subpart K - Private Coast Stations and Marine Utility Stations
- 80 Subpart S - Compulsory Radiotelephone Installations for Small Passenger Boats
- 80 Subpart T - Radiotelephone Installation Required for Vessels on the Great Lakes
- 80 Subpart U - Radiotelephone Installations Required by the Bridge-to-Bridge Act
- 80 Subpart V - Emergency Position Indicating Radio beacons (EPIRB'S)
- 80 Subpart W - Global Maritime Distress and Safety System (GMDSS)
- 80 Subpart X - Voluntary Radio Installations
- 87 - Aviation Services
- 90 - Private Land Mobile Radio Services
- 94 - Private Operational-Fixed Microwave Service
- 95 Subpart A - General Mobile Radio Service (GMRS)
- 95 Subpart C - Radio Control (R/C) Radio Service
- 95 Subpart D - Citizens Band (CB) Radio Service
- 95 Subpart F - Interactive Video and Data Service (IVDS)

TEST INSTRUMENTATION LIST

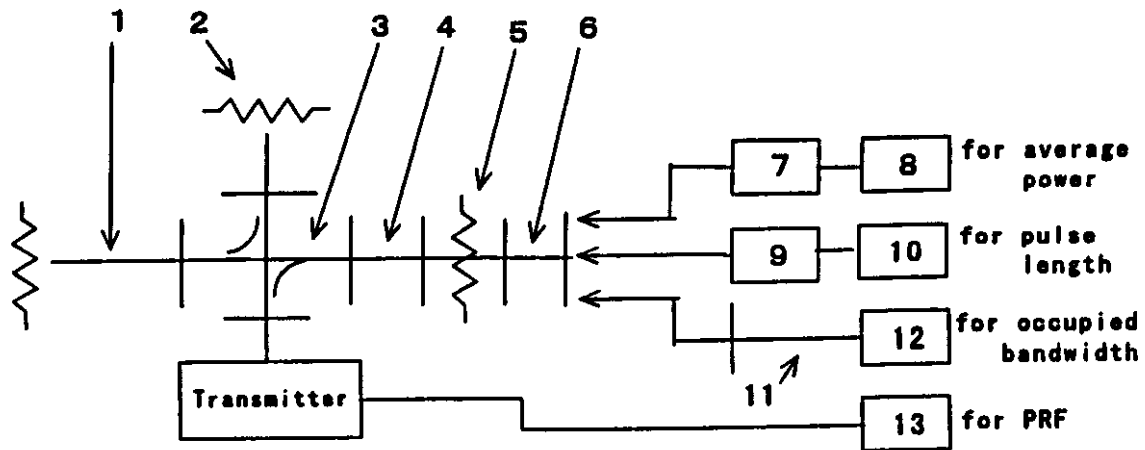

1	Dummy Load		X910B	HP
2	high power Dummy Load		4D371A	Shimada
3	Directional Coupler		5D351	Shimada
	Coupling	30 dB		
	Directivity	30 dB		
4	Frequency Meter		X532B	HP
5	Attenuator		X382A	HP
6	Adaptor		X281A	HP
7	Power Sensor		8481A	HP
8	Power Meter		435A	HP
9	Crystal Detector		423B	HP
10	Oscilloscope		465B	SONY / Tectronix
11	Coaxial Cable		MI-04	Takeda Riken
12	Spectrum Analyzer		8592A	Hewlett Packard
13	Frequency Counter		5300A	HP

Measurement Point ; Transmitter Output

1 Mechanical Tests

Appearance and Structure

Scanner Unit	Good
Display Unit	Good

2 Electrical Tests

2.1 Working of each operation unit

Scanner Unit	Good
Display Unit	Good
RANGE VOL	Good
SEA VOL	Good
RAIN VOL	Good
GAIN VOL	Good
TUNE VOL	Good
RANGE Switch	Good
EBL/VRM Switch	Good
FEBL Switch	Good
ZOOM Switch	Good
OFFSET Switch	Good
RR/SHM Switch	Good
TM/RM Switch	Good
HDG/MOOD Switch	Good
BRIL Switch	Good
DESIG Switch	Good
M.O.B Switch	Good
WINDOW Switch	Good
GUARD Switch	Good
ACQ/CNL Switch	Good
MENU Switch	Good
ENTER Switch	Good
ST-BY / OFF Switch	Good
X-MIT / OFF Switch	Good
TRACK BALL	Good

2.2 Scanner unit

VSWR	frequency (MHz)	VSWR
	9415	1.35
	9445	1.15
	9475	1.40
Scanner Rotation Speed		24 rpm

2.3 Transmitter

Magnetron Ser. No.	No. SF5B/E5748B
Operating Frequency (at 0.25 n.m.)	9420 MHz
(at 3.0 n.m.)	9419 MHz
(at 6.0 n.m.)	9419 MHz
(at 48.0 n.m.)	9419 MHz
Peak Output Power (at 0.25 n.m.)	8.75 KW
(at 3.0 n.m.)	9.15 KW
(at 6.0 n.m.)	9.35 KW
(at 48.0 n.m.)	9.14 KW
Pulse Length (at 0.25 n.m.)	0.11 μ S
(at 3.0 n.m.)	0.41 μ S
(at 6.0 n.m.)	0.84 μ S
(at 48.0 n.m.)	1.20 μ S
Diode limiter Ser. No.	No. B0703A

2.4 Receiver

MIC Frontend Ser. No.	No .D0619A
IF Center Frequency	60 MHz
IF Band Width	20 MHz/ 6 MHz/ 3 MHz

2.5 Display

Input Voltage and Current	
(at 0.25 n.m.)	24V 4.0A
(at 3.0 n.m.)	24V 4.4A
(at 6.0 n.m.)	24V 4.4A
(at 48.0 n.m.)	24V 4.4A
Repetition Frequency	
(at 0.25 n.m.)	1932 Hz
(at 3.0 n.m.)	1452 Hz
(at 6.0 n.m.)	726 Hz
(at 48.0 n.m.)	483 Hz

3 Overall Tests

Working time of Timer	1 m 30 s
Input Variation (10.8 V dc - 48 V dc)	Good
Overall Sensitivity	Good
Minimum Range	Good
Bearing Accuracy	Good
Mechanical Noise	Good

(Sec.2.985) 1.0 RF Power Output

(Sec.2.989) 2.0 Occupied Bandwidth

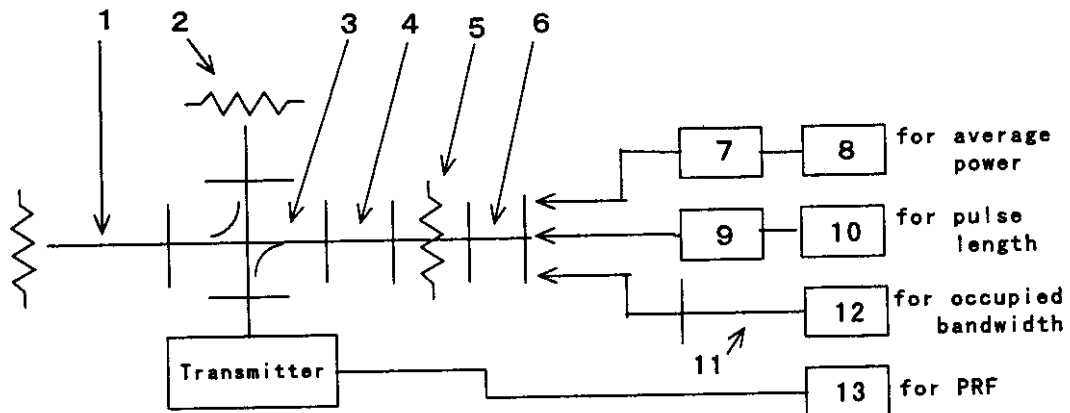

1	Dummy Load	X910B	HP
2	high power Dummy Load	4D371A	Shimada
3	Directional Coupler	5D351	Shimada
	Coupling	30 dB	
	Directivity	30 dB	
4	Frequency Meter	X532B	HP
5	Attenuator	X382A	HP
6	Adaptor	X281A	HP
7	Power Sensor	8481A	HP
8	Power Meter	435A	HP
9	Crystal Detector	423B	HP
10	Oscilloscope	465B	SONY / Tectronix
11	Coaxial Cable	MI-04	Takeda Riken
12	Spectrum Analyzer	8592A	Hewlett Packard
13	Frequency Counter	5300A	HP

Measurement Point ; Transmitter Output

CKEJMA3811

NAME OF TEST: MODULATION CHARACTERISTICS -
MODULATION LIMITING
PARAGRAPH: 47 CFR 2.987 (b)

GUIDE:

TEST CONDITIONS: N/A

TEST EQUIPMENT: N/A

PLEASE SEE SCHMATIC, ATTACHED

FCC Submittal Material Data

(Sec. 2. 985)

1. 0 RF Power Output

1. 1 Peak Power	(at 0. 25 n. m.)	8. 75 KW
	(at 3. 0 n. m.)	9. 15 KW
	(at 6. 0 n. m.)	9. 35 KW
	(at 48. 0 n. m.)	9. 14 KW

1. 2 Average Power	(at 0. 25 n. m.)	1. 86 W
	(at 3. 0 n. m.)	5. 45 W
	(at 6. 0 n. m.)	5. 70 W
	(at 48. 0 n. m.)	5. 30 W

VSWR 1. 05 at 9. 4 - 9. 5 GHz

Type

4D371A (Shimada co.)

(Sec. 2. 989)

2.0 Occupied Bandwidth

2.1 Short Pulse PRF 1932 Hz
Short Pulse Length 0.11 μ S

Scale
10dB/Div

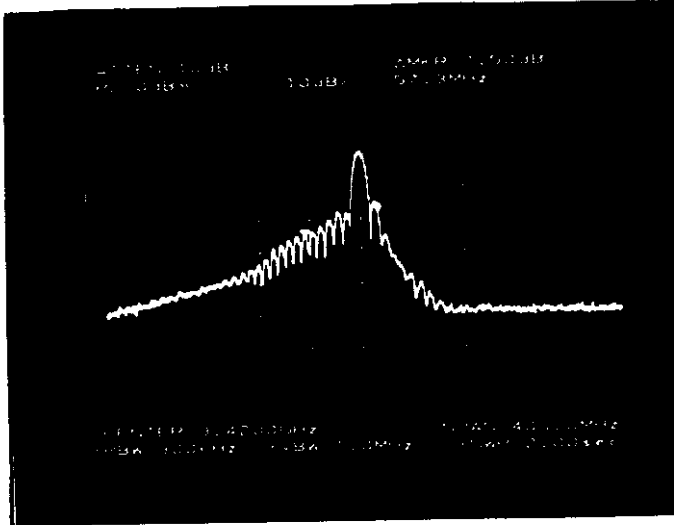

RF Spectrum
Short Pulse

OBW=57.3 MHz

Scale 40 MHz/ Div
Center Frequency 9420 MHz

(Sec. 2. 987)

Scale
20mV/Div

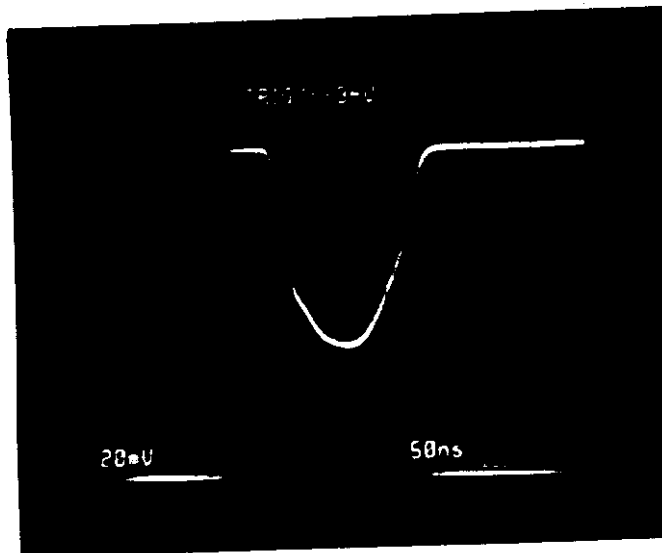

← 3dB

Detected RF
Pulse

Short Pulse

Scale 50ns/Div

(Sec. 2.989) 2.2 ShortMedium Pulse PRF 1452 Hz
ShortMedium Pulse Length 0.41 μ S

Scale
10dB/Div

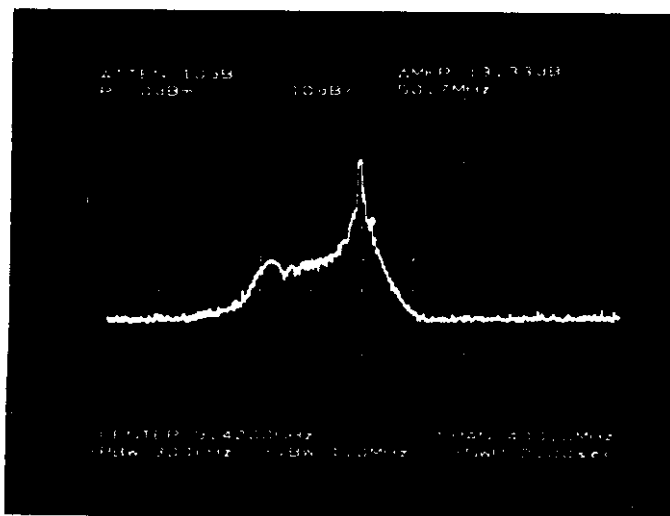

RF Spectrum
ShortMedium Pulse

OBW=50.7 MHz

Scale 40 MHz/ Div
Center Frequency 9419 MHz

(Sec. 2.987)

Scale
20mV/Div

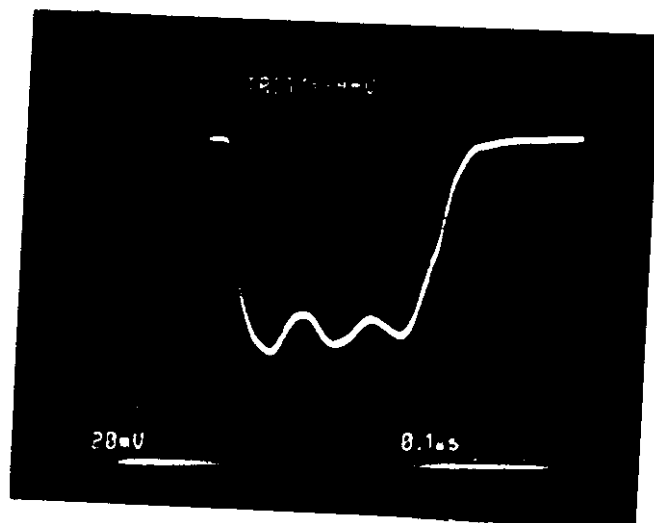

← 3dB

Detected RF
Pulse

ShortMedium Pulse

Scale 100nS/Div

(Sec. 2.989)

2.2 LongMedium Pulse PRF

726 Hz

LongMedium Pulse Length

0.84 μ S

Scale
10dB/Div

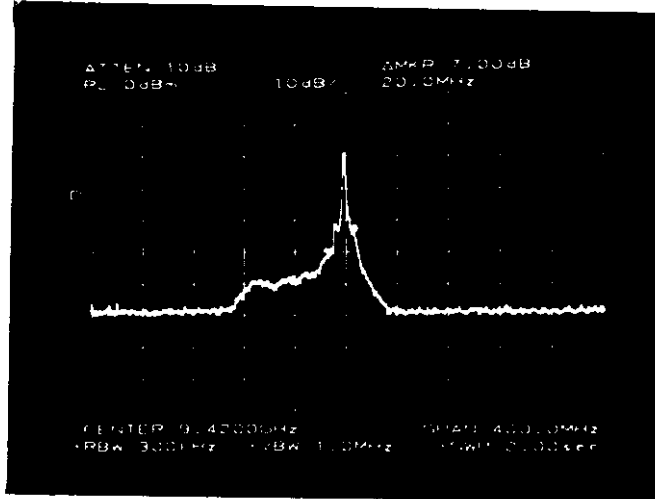

RF Spectrum
LongMedium Pulse

OBW=20.0 MHz

Scale 40 MHz/ Div

Center Frequency 9419 MHz

(Sec. 2.987)

Scale
20mV/Div

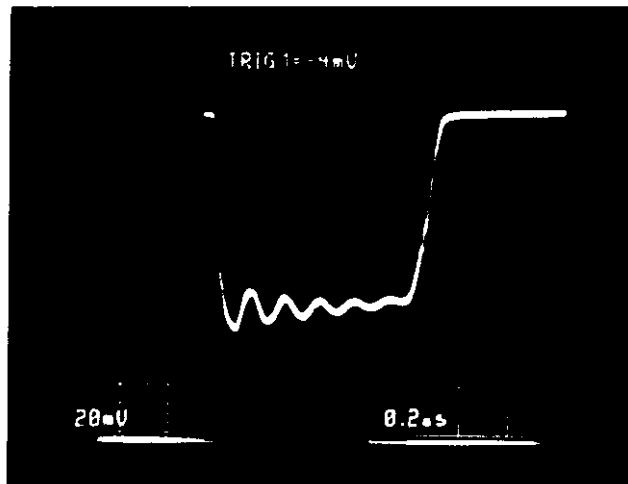

← 3dB

Detected RF
Pulse

LongMedium Pulse

Scale 200nS/Div

(Sec. 2.989)

2.3 Long Pulse PRF

483 Hz

Long Pulse Length

1.20 μ S

Scale
10dB/Div

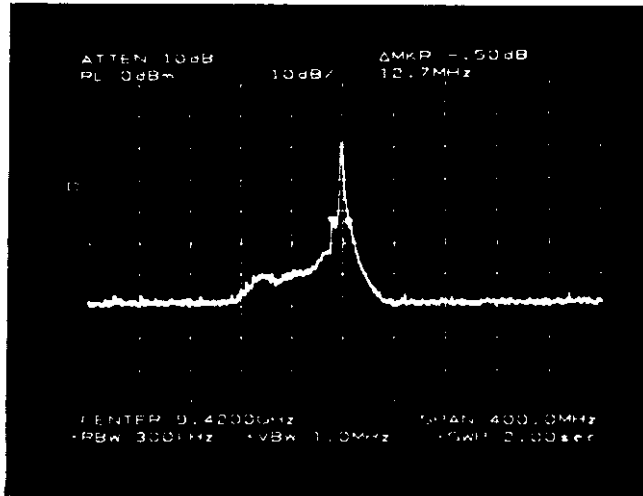

RF Spectrum
Long Pulse

OBW=12.7 MHz

Scale 40 MHz/ Div
Center Frequency 9419 MHz

(Sec. 2.987)

Scale
20mV/Div

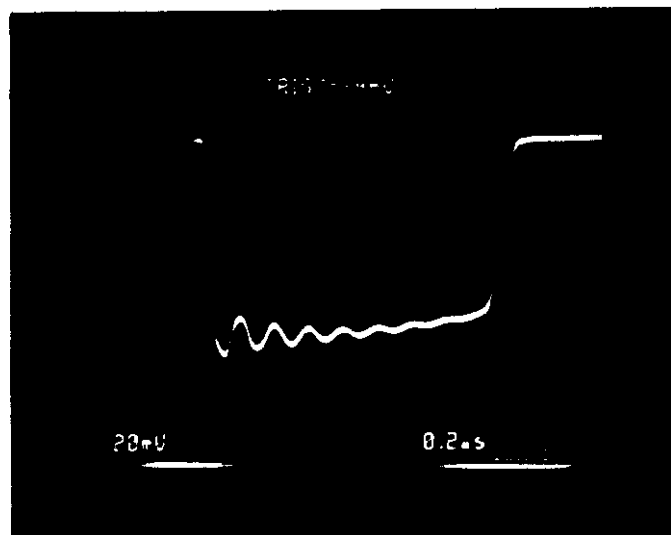

Detected RF
Pulse

Long Pulse

Scale 200 nS/Div

(Sec. 2. 991)

3.0 Spurious signals at antenna port

Condition 1; 0 to 20 GHz

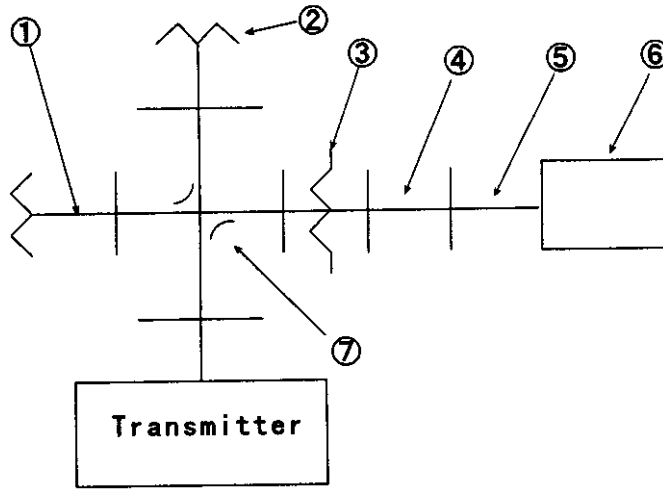

1	Dummy Load	X910B	HP
2	High power Dummy Load	4D371A	Shimada
3	Attenuator	X382A	HP
4	Adaptor	X281A	HP
5	Coaxial Cable	MI-04	Takeda Riken
6	Spectrum Analyzer	TR4133B	Takeda Riken
7	Directional Coupler	R11421	Shimada
	Coupling	30 dB	
	Directivity	30 dB	
★	Attenuation	3 ; 25dB	
★	Measurement Point	Rotary Joint Output	

(Sec. 2.991)

Scale
↑ 10dB/Div
→ 400 MHz
/Div

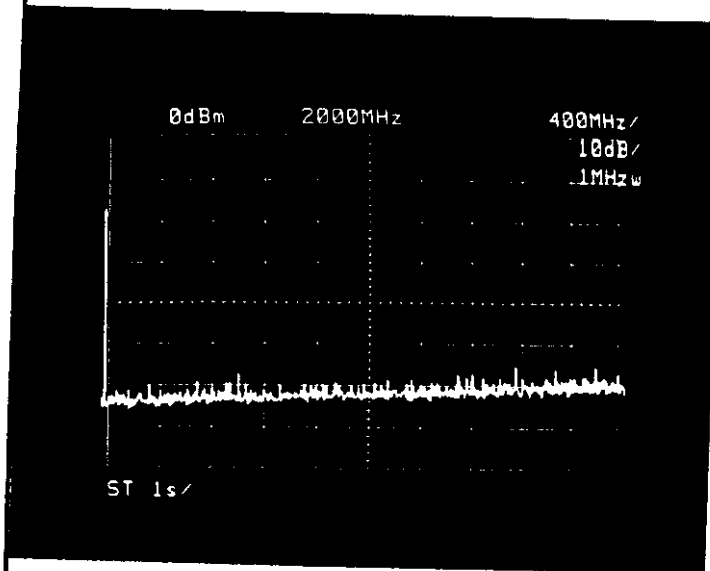

Spurious
Signals

OFF

0 to 3.6 GHz

Scale
↑ 10dB/Div
→ 400 MHz
/Div

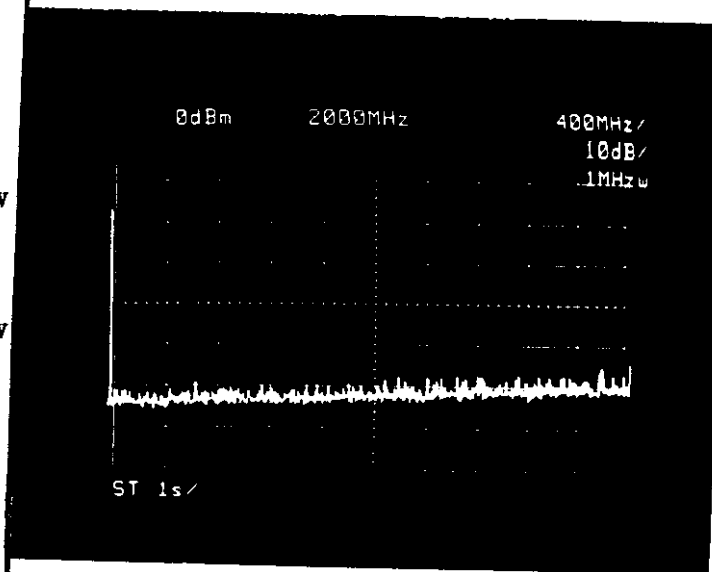

Spurious
Signals

Stand-By

0 to 3.6 GHz

Scale
↑ 10dB/Div
→ 400 MHz
/Div

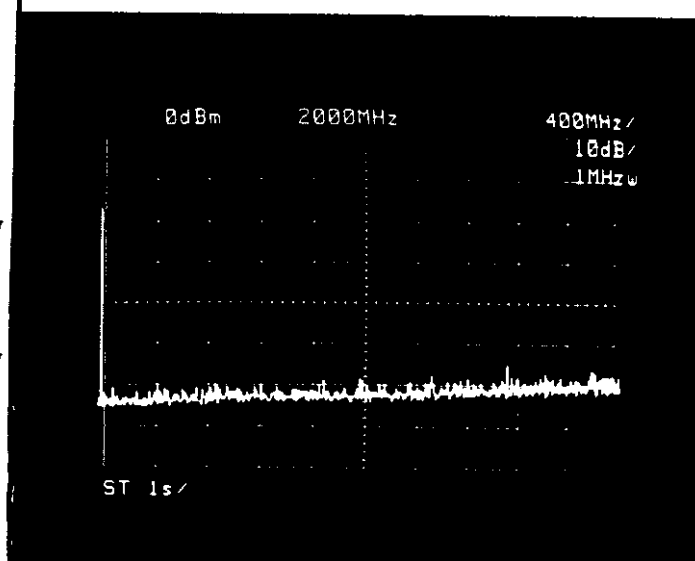

Spurious
Signals

Short Pulse

0 to 3.6 GHz

(Sec. 2.991)

Scale
↑ 10dB/Div
→ 400 MHz
/Div

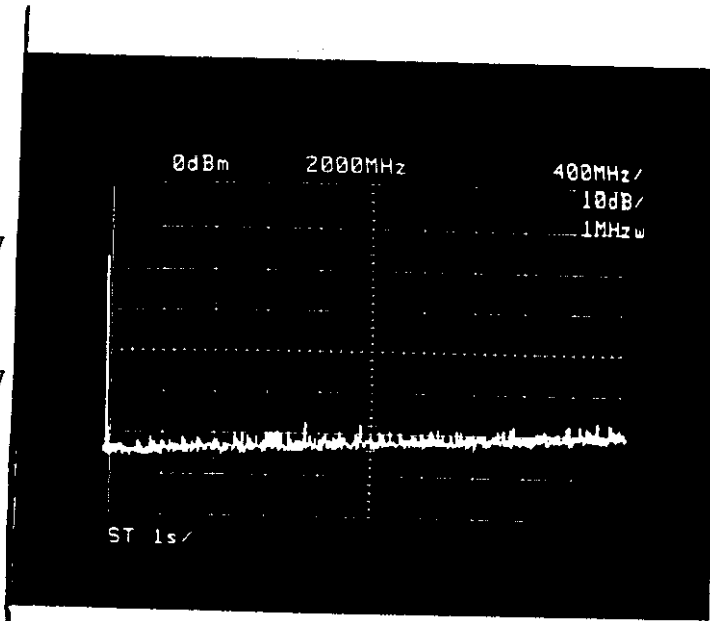

Spurious
Signals

Short Medium
Pulse

0 to 3.6 GHz

Scale
↑ 10dB/Div
→ 400 MHz
/Div

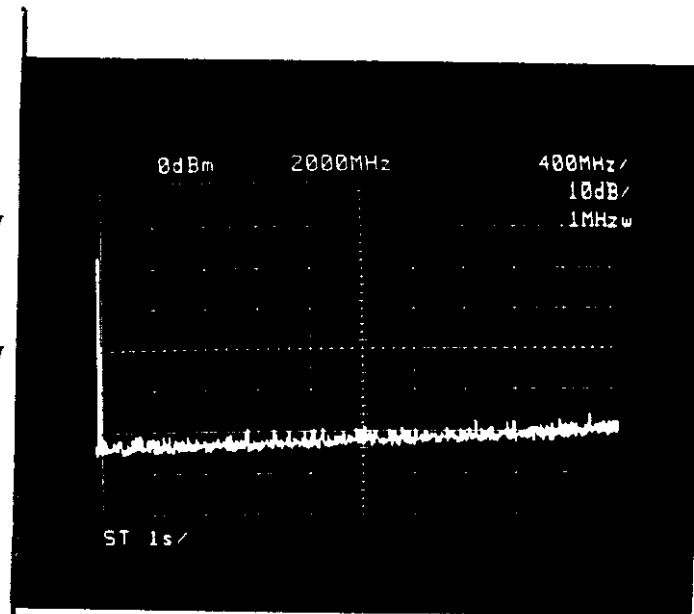

Spurious
Signals

Long Medium
Pulse

Scale
↑ 10dB/Div
→ 400 MHz
/Div

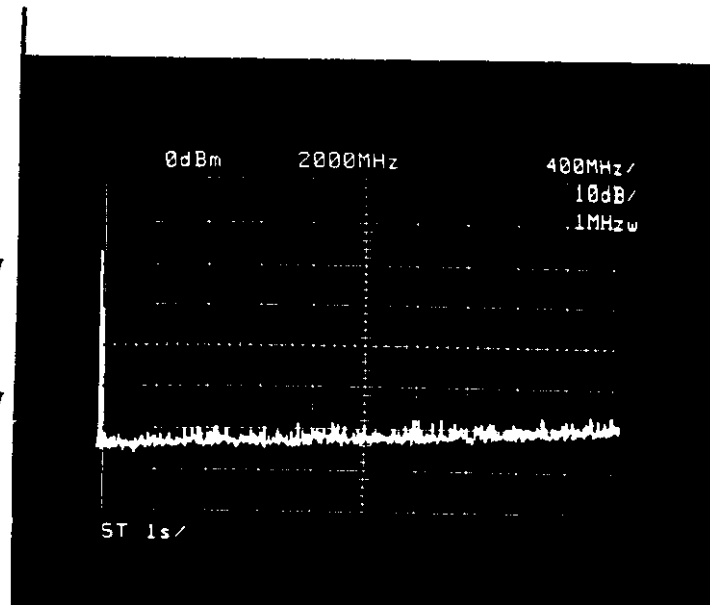

0 to 3.6 GHz
Spurious
Signals

Long Pulse

0 to 3.6 GHz

(Sec. 2.991)

Scale
↑ 10dB/Div

→ 400 MHz
/Div

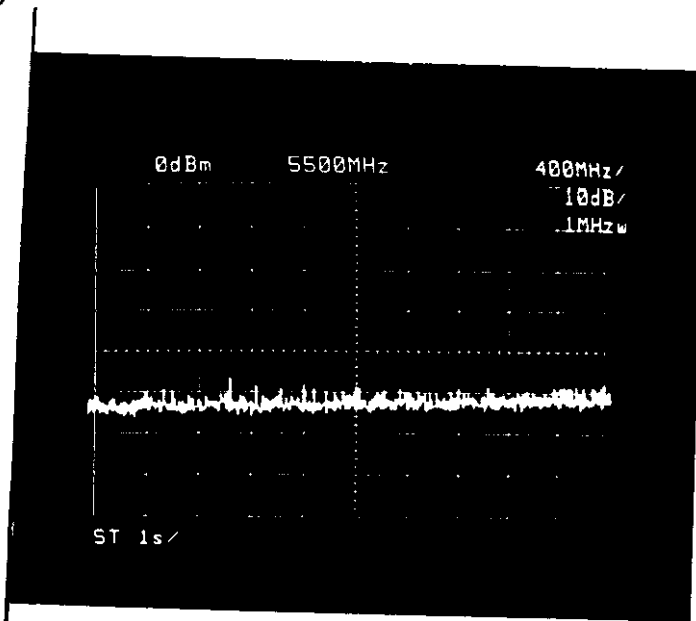

Spurious
Signals

OFF

3.5 to 7.5 GHz

Scale
↑ 10dB/Div

→ 400 MHz
/Div

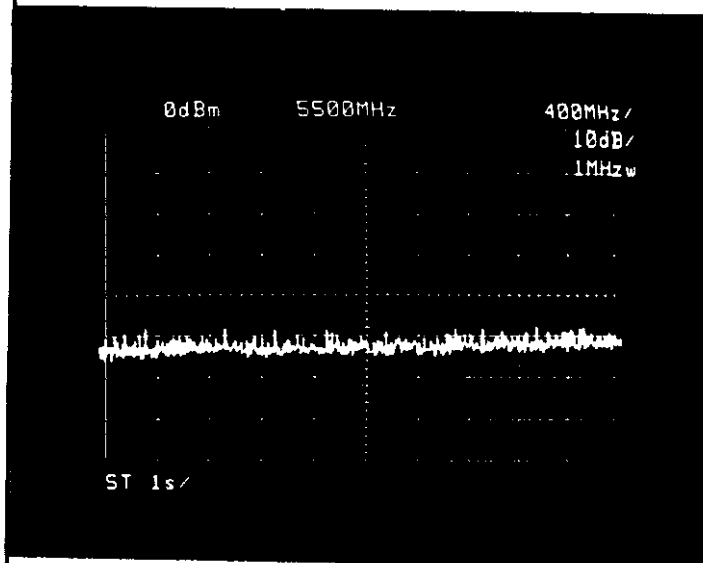

Spurious
Signals

Stand-By

3.5 to 7.5 GHz

Scale
↑ 10dB/Div

→ 400 MHz
/Div

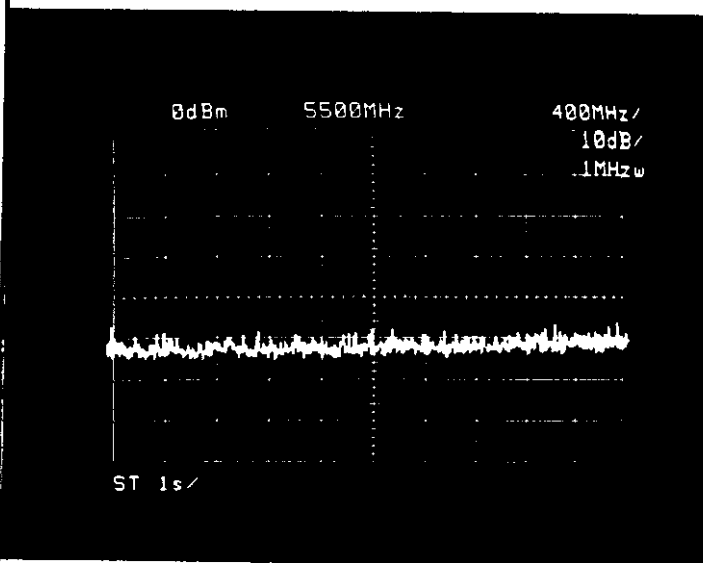

Spurious
Signals

Short Pulse

3.5 to 7.5 GHz

(Sec. 2.991)

Scale
↑ 10dB/Div
→ 400 MHz
/Div

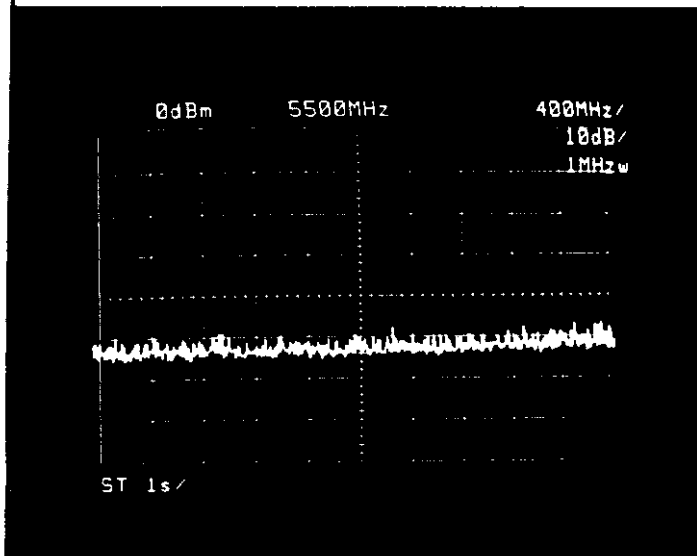

Spurious
Signals

Short Medium
Pulse

3.5 to 7.5 GHz

Scale
↑ 10dB/Div
→ 400 MHz
/Div

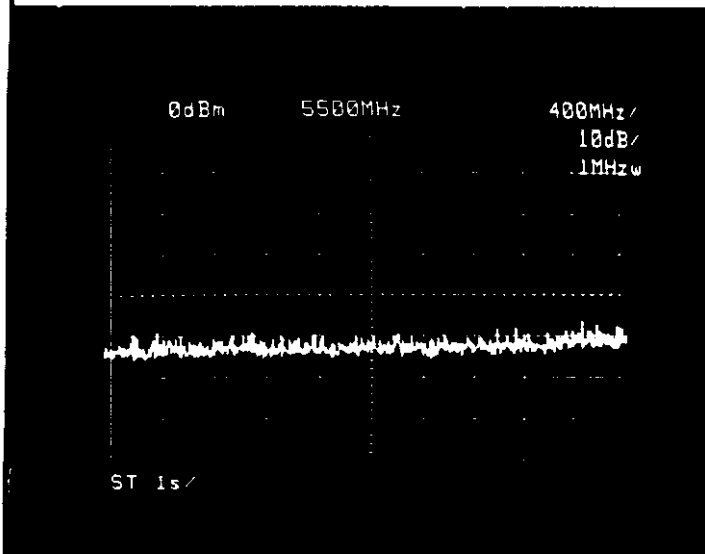

Spurious
Signals

Long Medium
Pulse
3.5 to 7.5 GHz

Scale
↑ 10dB/Div
→ 400 MHz
/Div

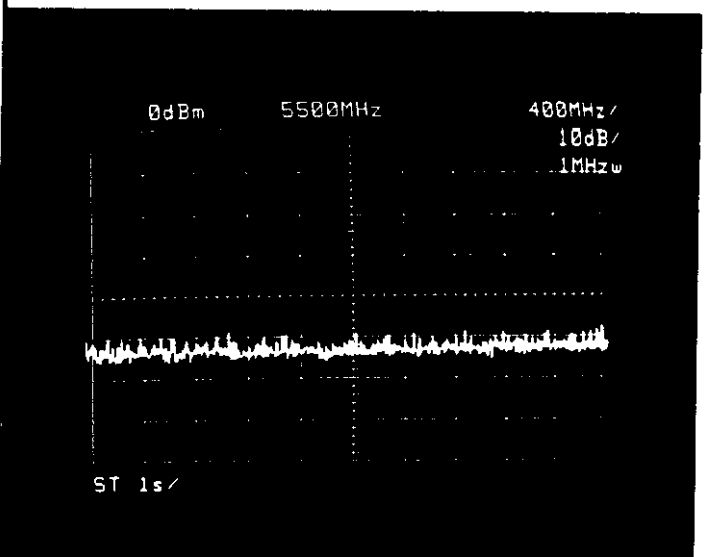

Spurious
Signals

Long Pulse
3.5 to 7.5 GHz

(Sec. 2.991)

Scale
↑ 10dB/Div
→ 800 MHz
/Div

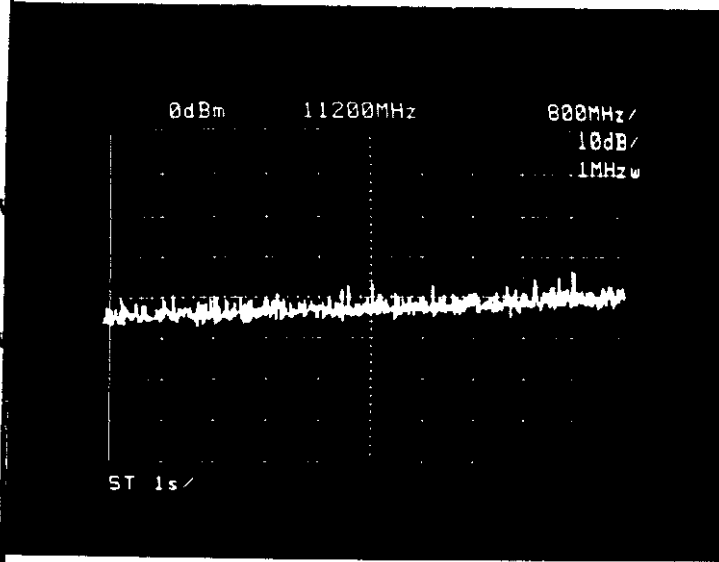

Spurious
Signals

OFF

7.2 to 15.2 GHz

Scale
↑ 10dB/Div
→ 800 MHz
/Div

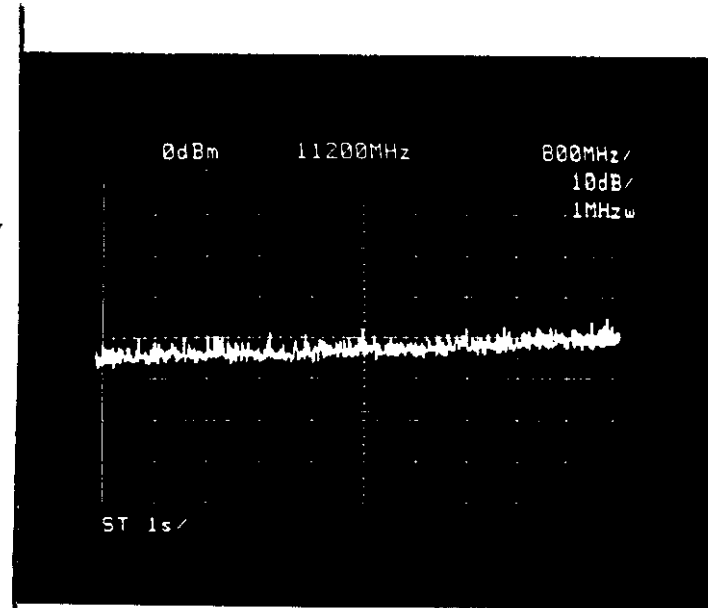

Spurious
Signals

Stand-By

7.2 to 15.2 GHz

Scale
↑ 10dB/Div
→ 800 MHz
/Div

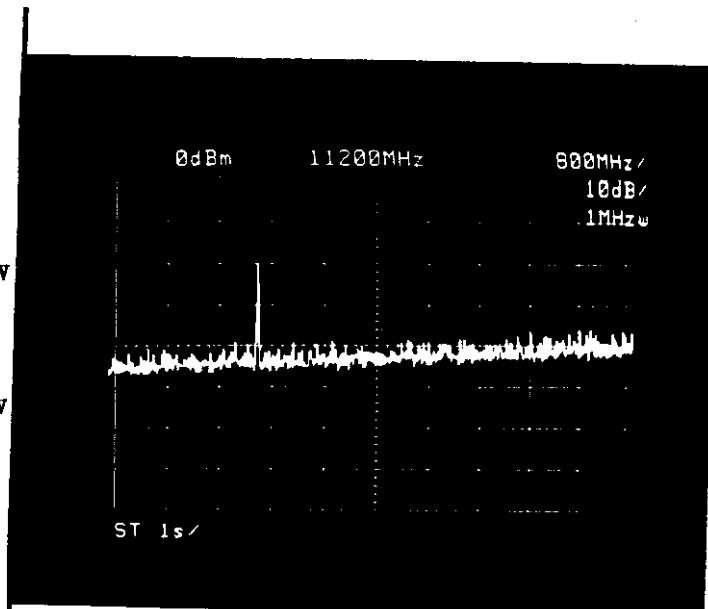

Spurious
Signals

Short Pulse

7.2 to 15.2 GHz

(Sec. 2.991)

Scale
↑ 10dB/Div
→ 800 MHz
/Div

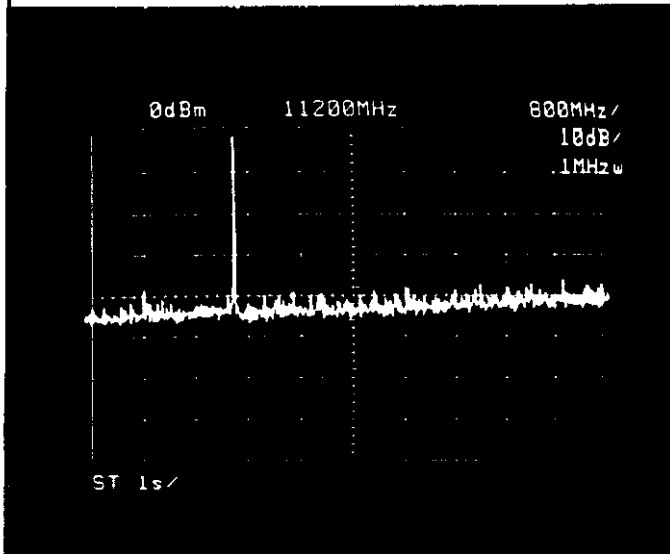

Spurious
Signals

Short Medium
Pulse

7.2 to 15.2 GHz

Scale
↑ 10dB/Div
→ 800 MHz
/Div

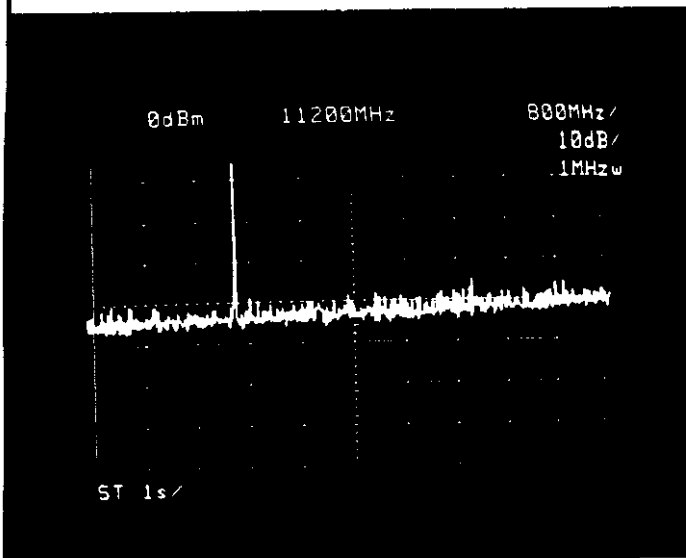

Spurious
Signals

Long Medium
Pulse

7.2 to 15.2 GHz

Scale
↑ 10dB/Div
→ 800 MHz
/Div

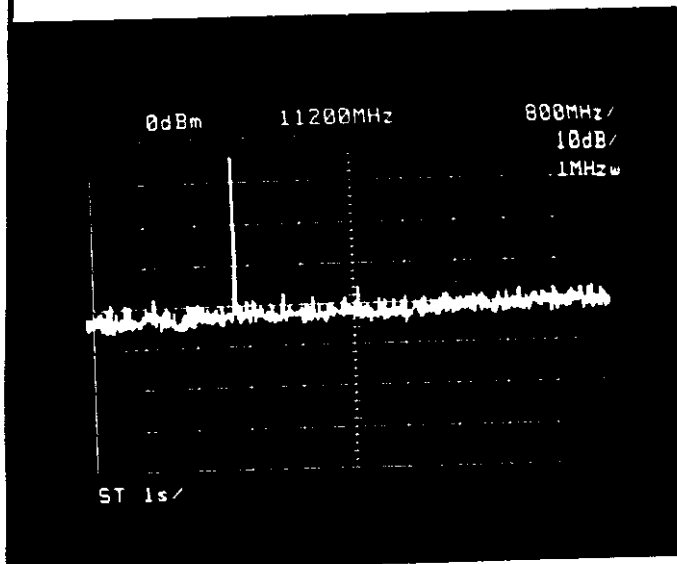

Spurious
Signals

Long Pulse

7.2 to 15.2 GHz

(Sec. 2. 991)

Scale
↑ 10dB/Div

→ 1.2 GHz
/Div

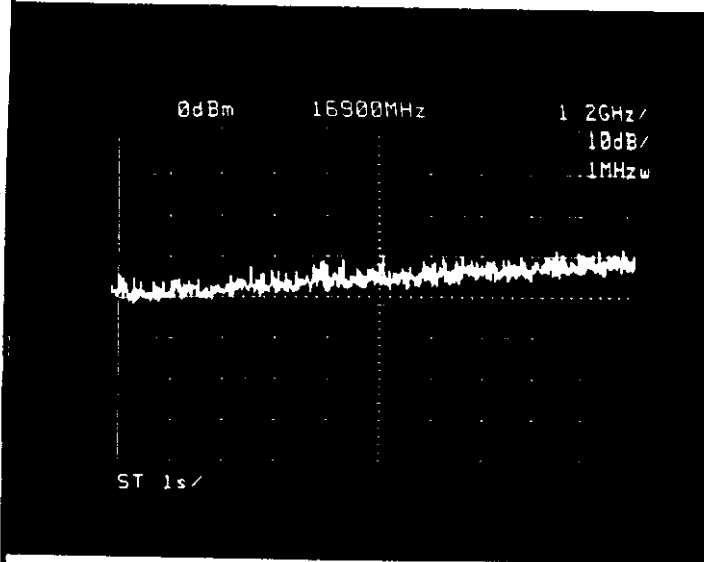

Spurious
Signals

OFF

10.9 to 20 GHz

Scale
↑ 10dB/Div

→ 1.2 GHz
/Div

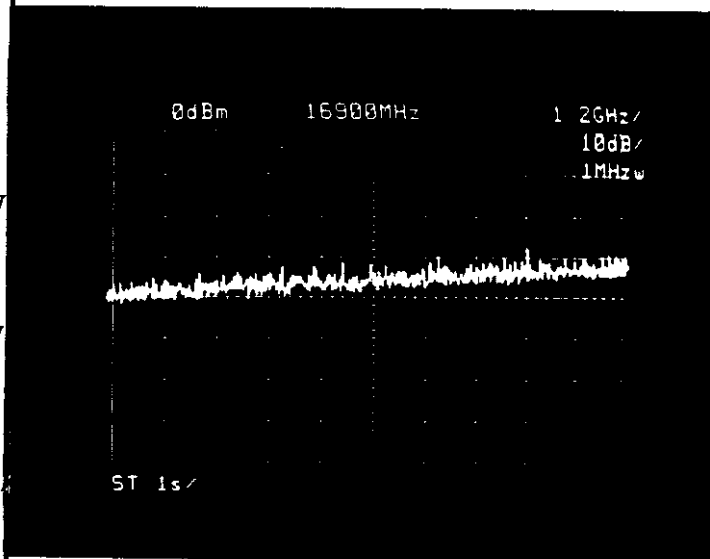

Spurious
Signals

Stand-By

10.9 to 20 GHz

Scale
↑ 10dB/Div

→ 1.2 GHz
/Div

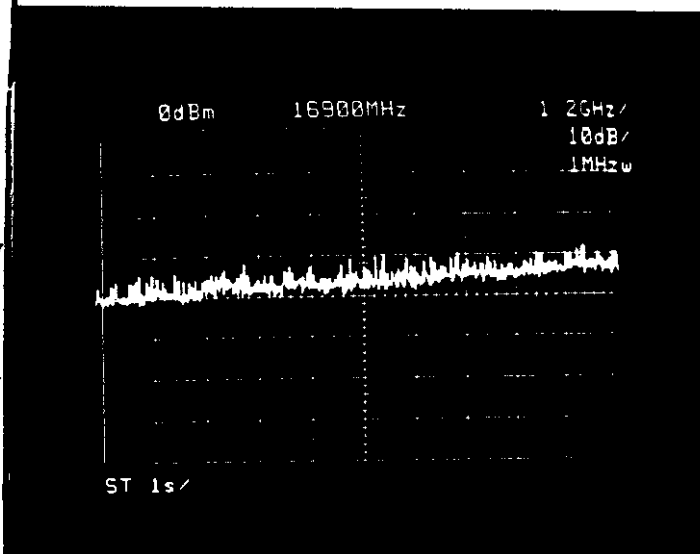

Spurious
Signals

Short Pulse

10.9 to 20 GHz

(Sec. 2. 991)

3.0 Spurious signals at antenna port

Condition 2; 12.4 to 40 GHz

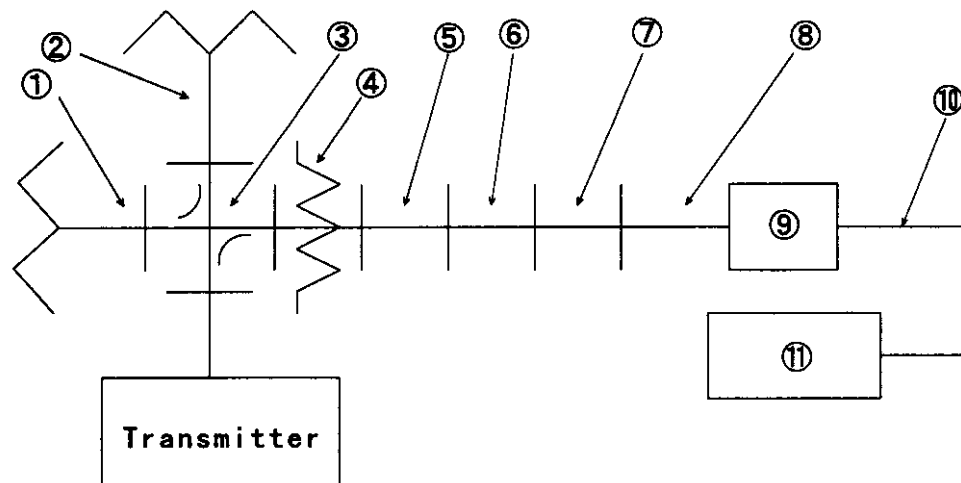

1	Dummy Load	X910B	HP
2	High power Dummy Load	4D371A	Shimada
3	Directional Coupler	R11421	Shimada
	Coupling	30 dB	
	Directivity	30 dB	
4	Attenuator	X382A	HP
5	Tapered W/G	195-X KU	AIRCOM
6	Tapered W/G	11818A	HP
7	Tapered W/G	11519A	HP
8	Tapered W/G	11520A	HP
9	External Mixer	11517A	HP
10	Coaxial Cable	10503A	HP
11	Spectrum Analyzer	TR4133B	Takeda Riken

★ Attenuation on ATT4 ; 50dB

★ Measurement Point ; Rotary Joint Output

(Sec. 2. 991)

Scale
↑ 10dB/Div
→ 1.2 GHz
/Div

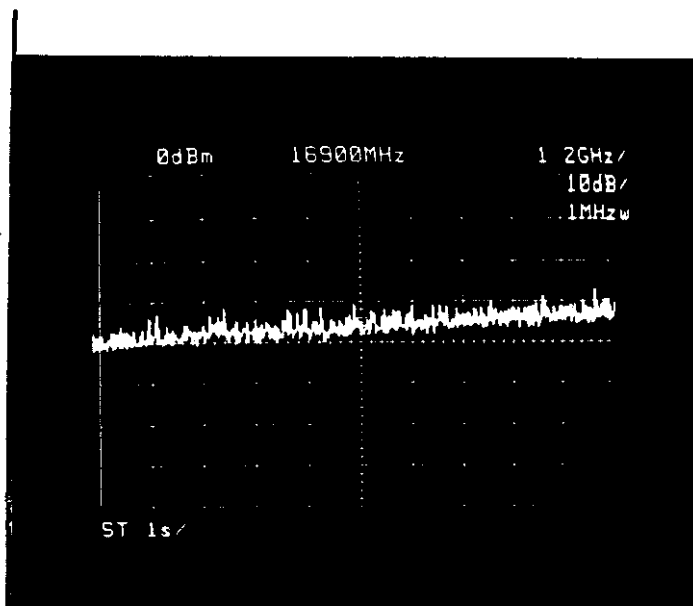

Spurious
Signals

Short Medium
Pulse

10.9 to 20 GHz

Scale
↑ 10dB/Div
→ 1.2 GHz
/Div

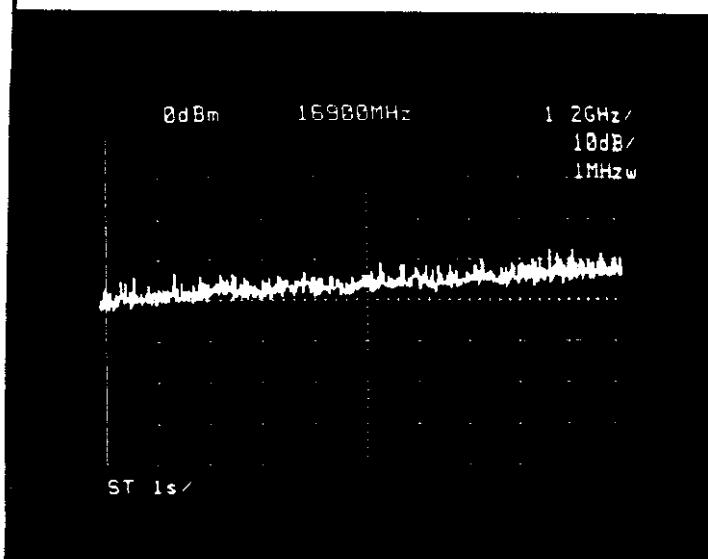

Spurious
Signals

Long Medium
Pulse

10.9 to 20 GHz

Scale
↑ 10dB/Div
→ 1.2 GHz
/Div

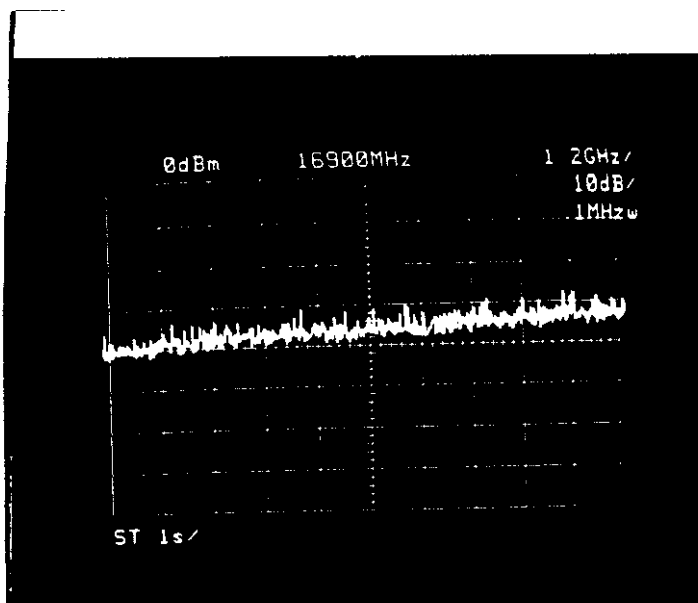

Spurious
Signals

Long Pulse

10.9 to 20 GHz

(Sec. 2. 991)

Scale
↑ 10dB/Div
→ 1.6 GHz
/Div

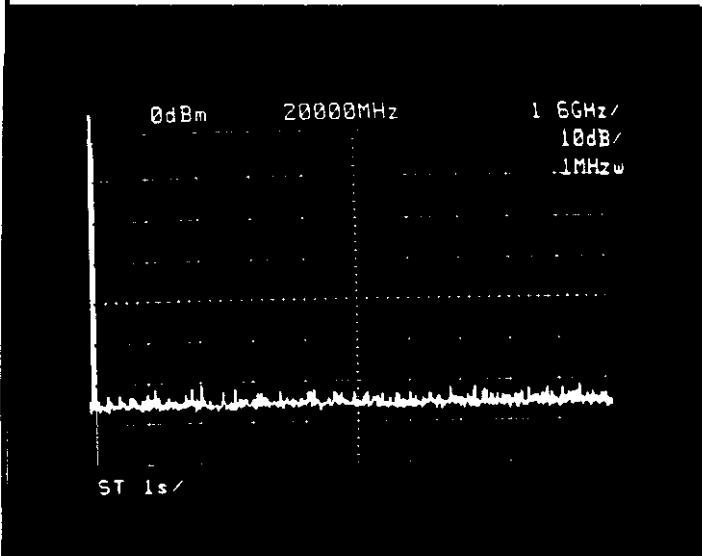

Spurious
Signals

OFF

12.4 to 28 GHz

Scale
↑ 10dB/Div
→ 1.6 GHz
/Div

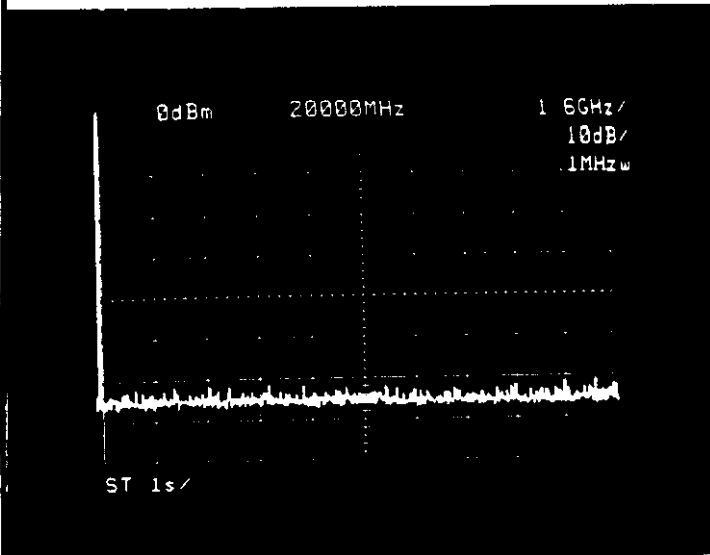

Spurious
Signals

Stand-By

12.4 to 28 GHz

Scale
↑ 10dB/Div
→ 1.6 GHz
/Div

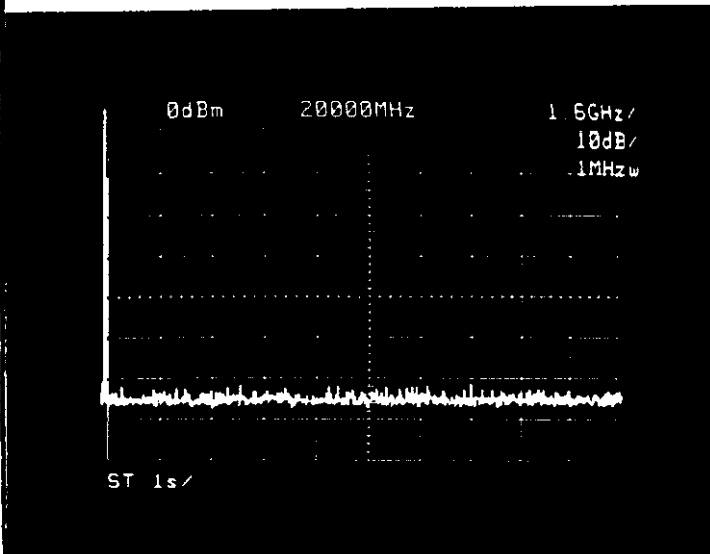

Spurious
Signals

Short Pulse

12.4 to 28 GHz

(Sec. 2.991)

Scale
↑ 10dB/Div
→ 1.6 GHz
/Div

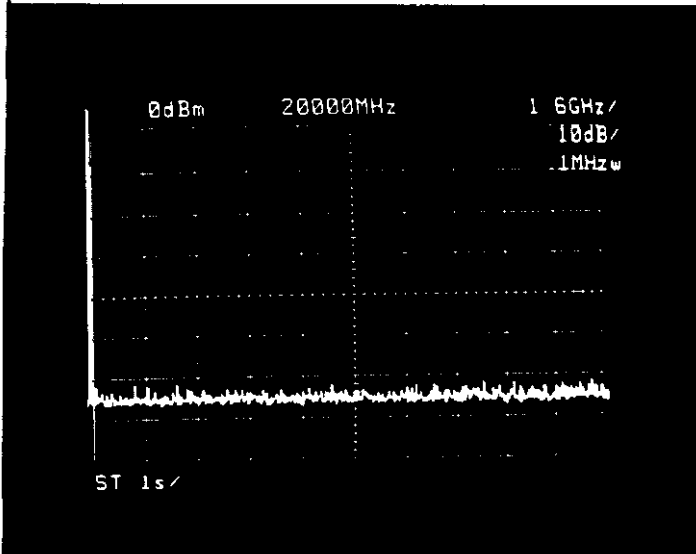

Spurious
Signals

Short Medium
Pulse

12.4 to 28 GHz

Scale
↑ 10dB/Div
→ 1.6 GHz
/Div

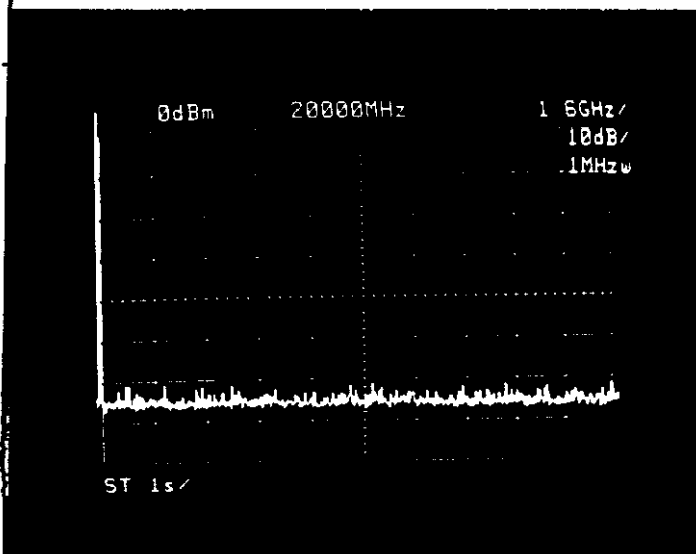

Spurious
Signals

Long Medium
Pulse
12.4 to 28 GHz

Scale
↑ 10dB/Div
→ 1.6 GHz
/Div

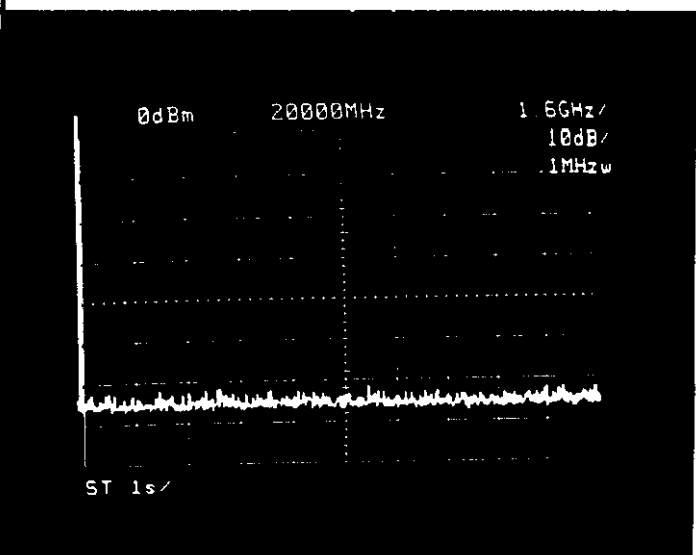

Spurious
Signals

Long Pulse

12.4 to 28 GHz

(Sec. 2. 991)

Scale
↑ 10dB/Div
→ 3. 2 GHz
/Div

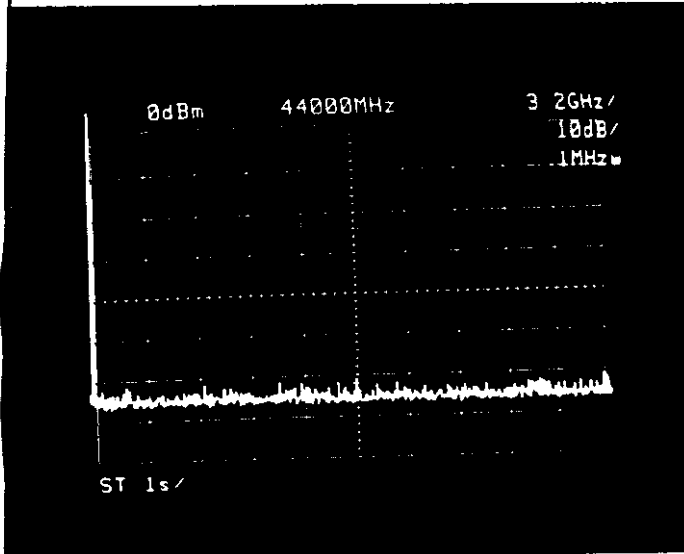

Spurious
Signals
Short Medium Pulse

28 to 60 GHz

Scale
↑ 10dB/Div
→ 3. 2 GHz
/Div

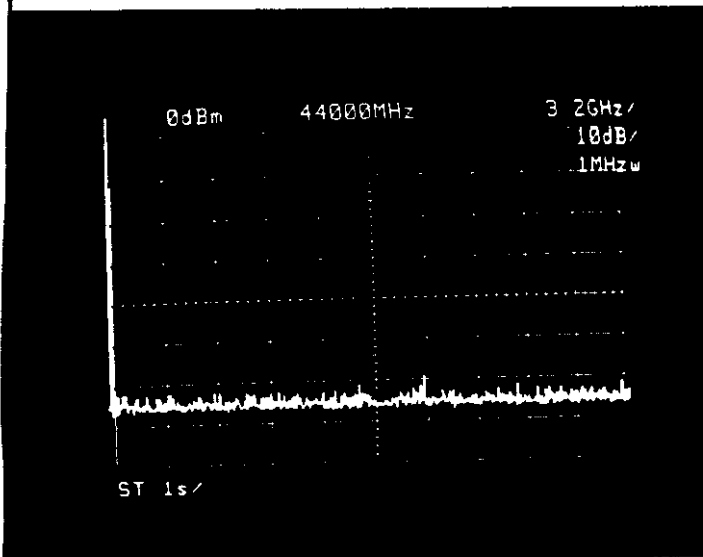

Spurious
Signals
Long Medium
Pulse
28 to 60 GHz

Scale
↑ 10dB/Div
→ 3. 2 GHz
/Div

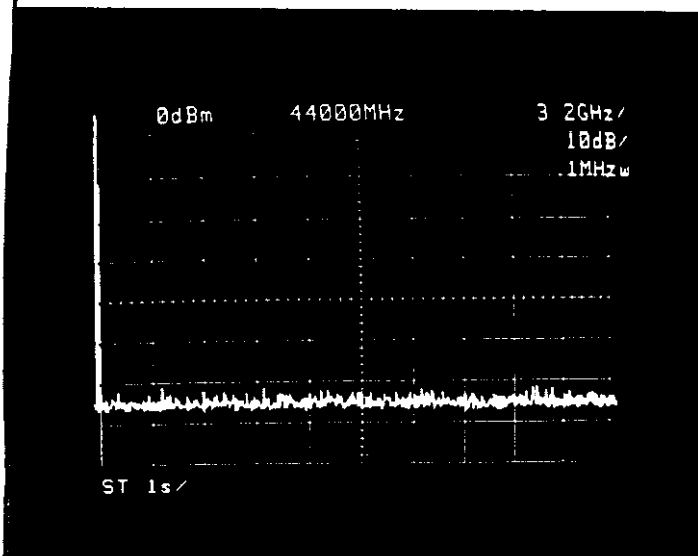

Spurious
Signals
Long Pulse
28 to 60 GHz

(Sec. 2.991)

Scale
↑ 10dB/Div

→ 3.2 GHz
/Div

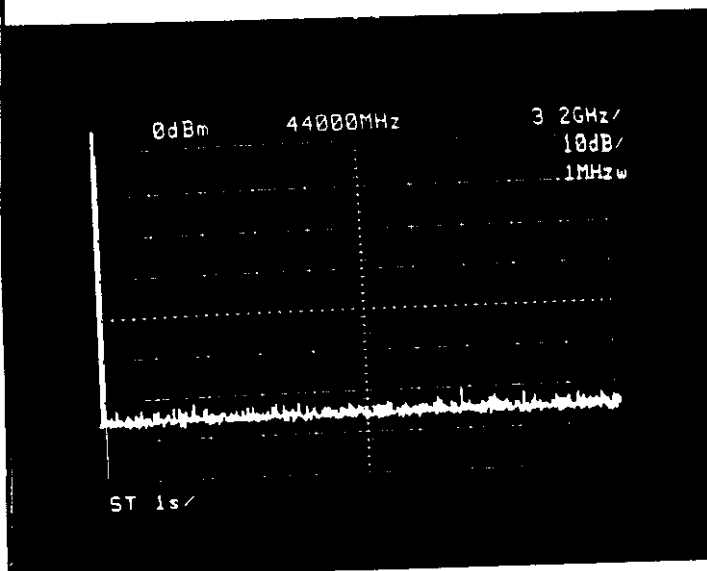

Spurious
Signals

OFF

28 to 60 GHz

Scale
↑ 10dB/Div

→ 3.2 GHz
/Div

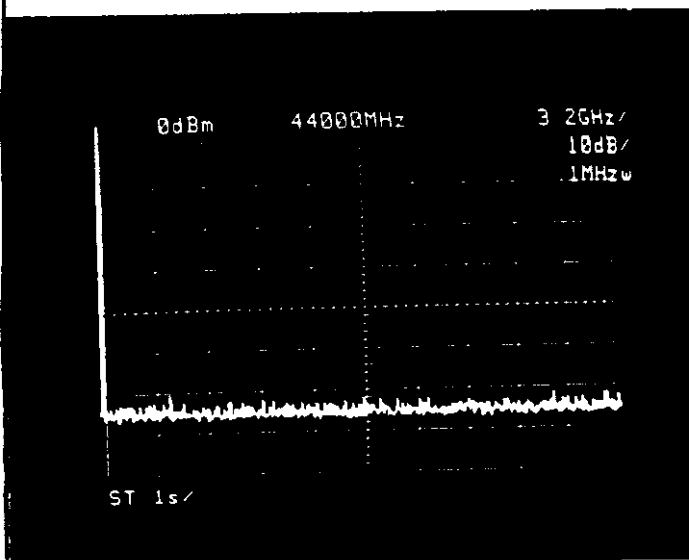

Spurious
Signals

Stand-By

28 to 60 GHz

Scale
↑ 10dB/Div

→ 3.2 GHz
/Div

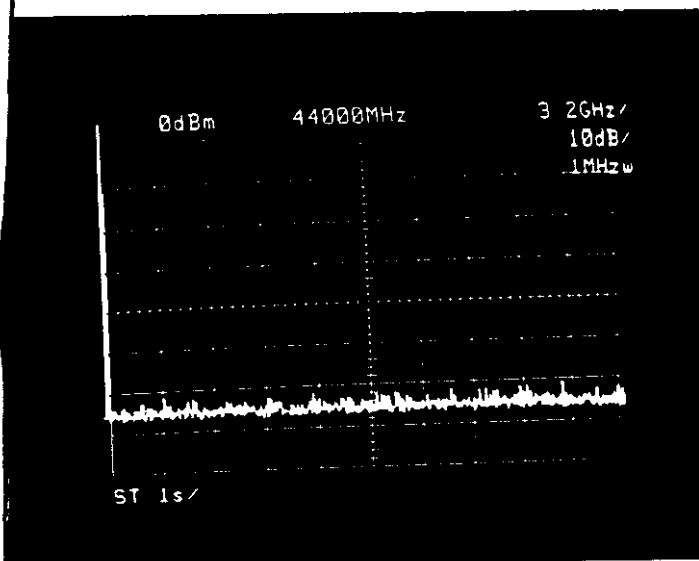

Spurious
Signals

Short Pulse

28 to 60 GHz

SECTION 5

TEST: Spurious Emissions Field Strength

EQUIPMENT: JMA-3811 S/N LE 5 9 2 2 0

FCC SPECIFICATION: Sections 2.993 and 80.211.

MINIMUM STANDARD: Mean power of emissions originating in equipment lowest generated frequency to at least 40 GHz shall be attenuated below the mean power of the transmitter by at least 43 plus 10 log (mean power in watts) decibels. Since transmitter mean power is 9.14 watts maximum (long pulse) or 39.61 dBm:

$$\begin{aligned} \text{Emissions} &\leq 39.61 \text{ dBm} - [43 + 10 \log(9.14)] \text{ dBm} \\ &\leq -13.0 \text{ dBm} \end{aligned}$$

TEST RESULTS: No spurious emissions observed above minimum standard.

TEST CONDITIONS: Tamb = 20°C to 25°C RHamb = 40% ~ 60%
Eout input = 12 VDC
Stabilization: UUT energized for 10 minutes minimum.

TEST EQUIPMENT: JRC Original - Shielded Room
Other equipment - see test set-ups.

DATE: 9 - 10 MAR. 1998

TEST ENGINEER: K. YUASA.

CALIBRATION OF TESTS 1~5 (0~1 GHz)

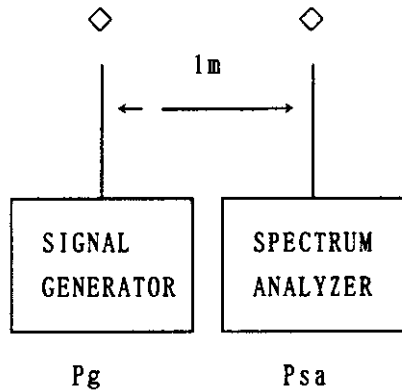

A signal source of known amplitude was used as a calibrating signal with identical antennas on the generator and the spectrum analyzer. From previous testing in the shielded room, the antenna factors are considered much greater than path loss. Hence half of the difference in signals P_g and P_{sa} is due to each antenna.

The calibrating signal on the analyzer is therefore:

$$P_{cal} = P_{sa} - (P_{sa} - P_g) / 2 = (P_{sa} + P_g) / 2 \text{ dBm.}$$

The log ref level on the analyzer is adjusted so as to read other signals directly:

$$\text{LRL (adjusted)} = \text{LRL (set)} + P_{cal} - P_{sa} \text{ dBm.}$$

The calibrating signal used was selected on the basis of best average amplitude over the frequency range of interest.

TEST	CAL sig	Psa	Pg	Pcal	LRL(set)	LRL(adj)
1	250 KHz	-66	0	-33.0	-10	23.0
2	2.5 MHz	-58	0	-28.0	-10	18.0
3	25 MHz	-28	0	-14.0	-10	4.0
4	250 MHz	-22	0	-11.0	-10	1.0
5	500 MHz	-28	0	-14.0	-10	4.0

RFI TEST

TEST SET-UP #1(0~50MHz)

TEST #1 0~500 KHz

TEST #2 0~ 5 MHz

TEST #3 0~ 50 MHz

TEST EQUIPMENT

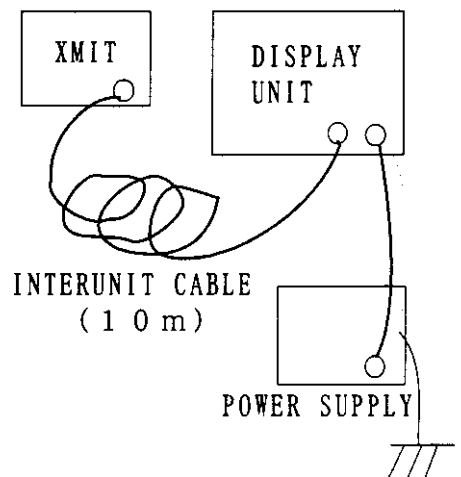
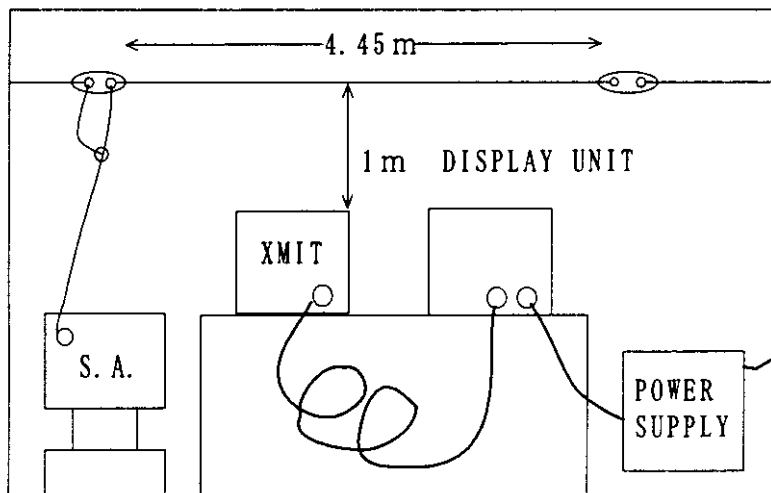
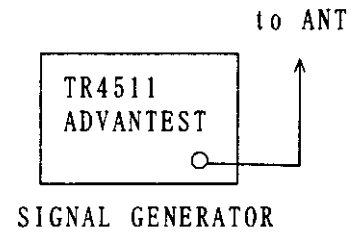
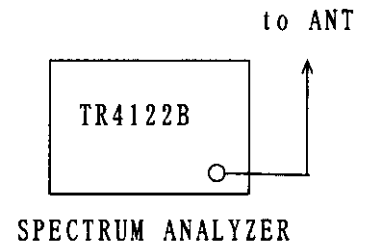
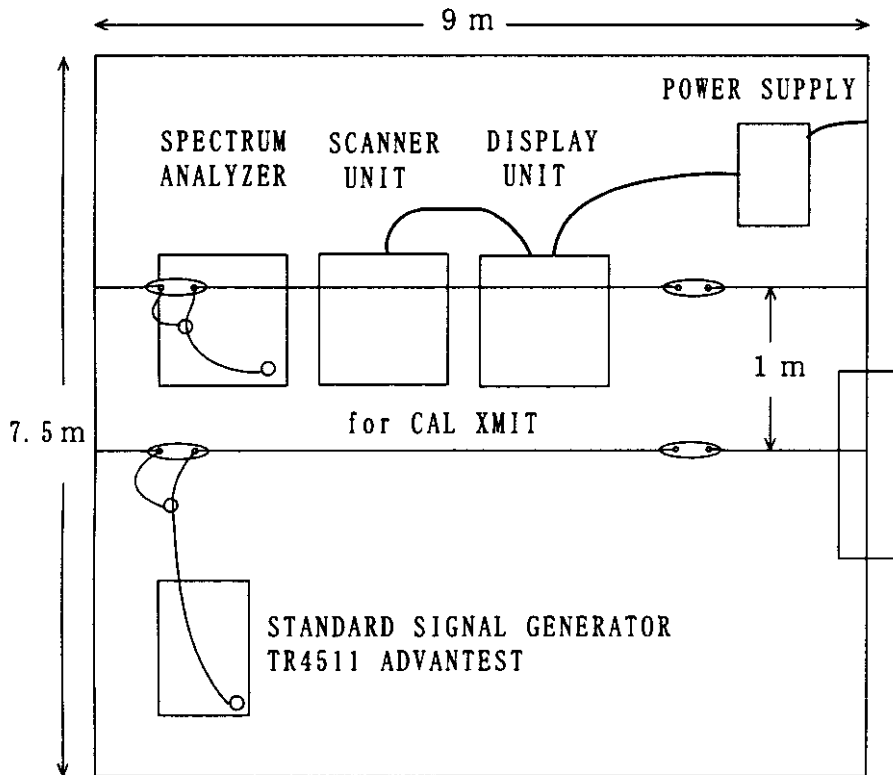

JRC ORIGINAL
RF ANECHOIC CHAMBER:SIDE VIEW

CABLE

TEST SET UP # 2 (5 0 MHz - 4 0 GHz)

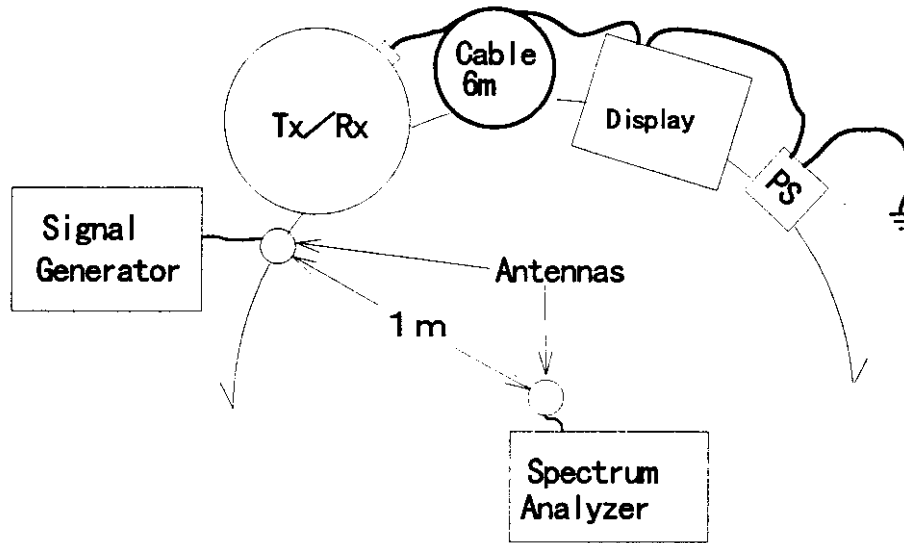

TABLE OF TEST EQUIPMENT USED

Frequency	Test Antenna	Spectrum Analyzer	Signal Generator	Misc.
0 - 1 0 0 0 MHz	1/2 Coaxial (Untuned)	TAKEDA RIKEN TR4133B	ADVANTEST TR4511	-
1 - 1 8 GHz	AILTECH 94612-1 Log Periodic	"	NA	-
1 8 - 2 6 GHz	AILTECH 94626-1 HP-11519A	"	NA	-
2 6 - 4 0 GHz	AILTECH 94627-1 HP-11519A	"	NA	-

TEST #1

Frequency Band: 0~500 KHz

Log Ref. Level: 23.0 dBm

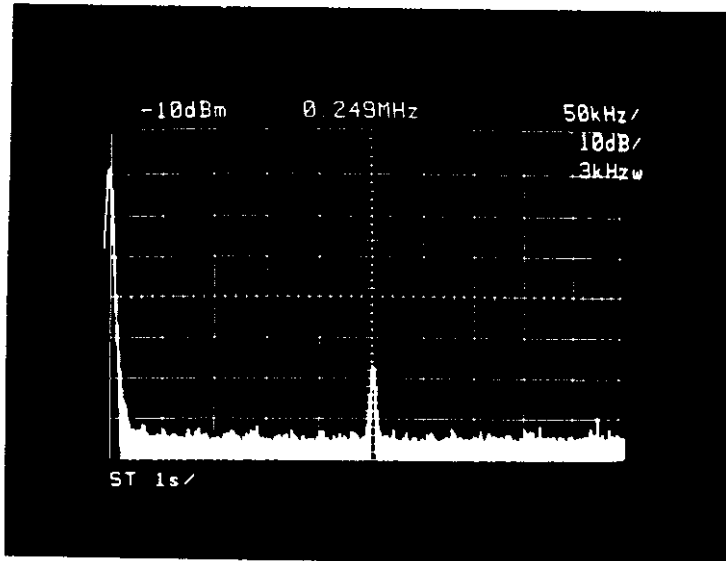

Ambient

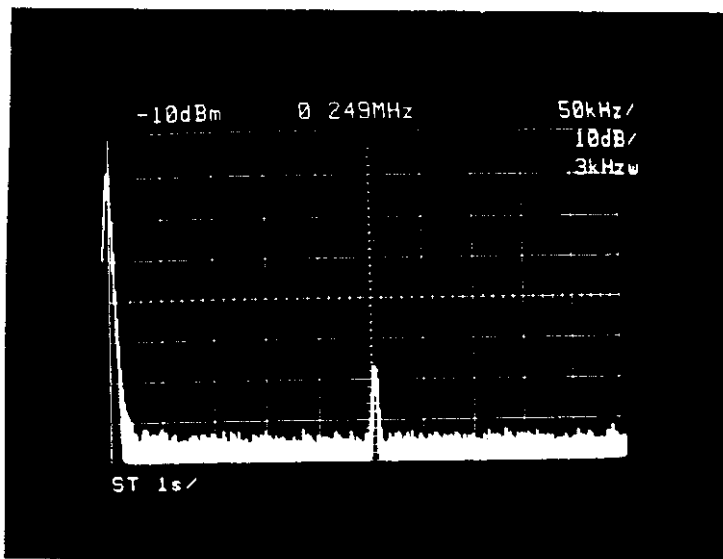

Stand-By

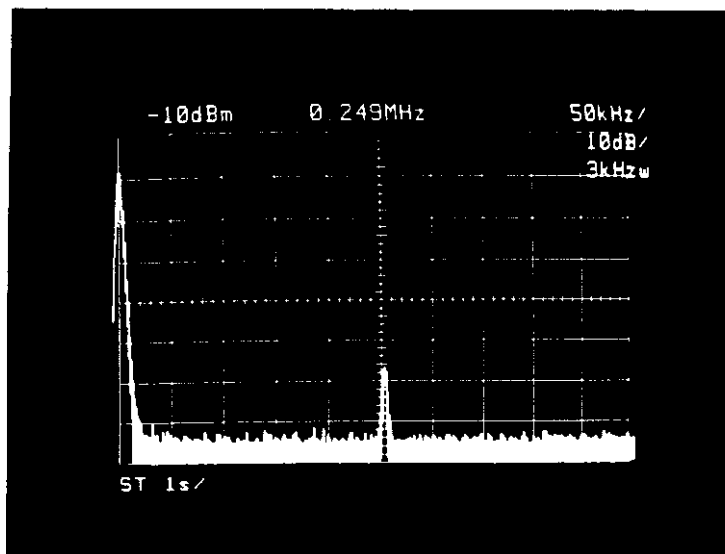

Short Pulse

TEST #1

Frequency Band: 0~500 KHz

Log Ref. Level: 23.0 dBm

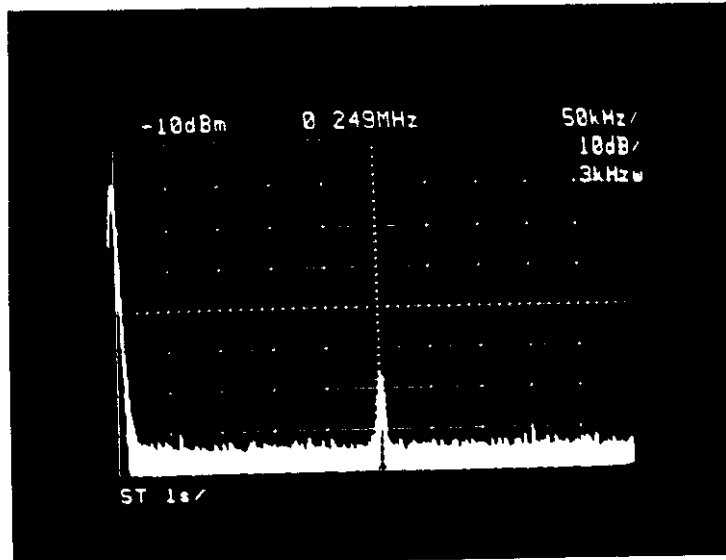

Medium
Short Pulse

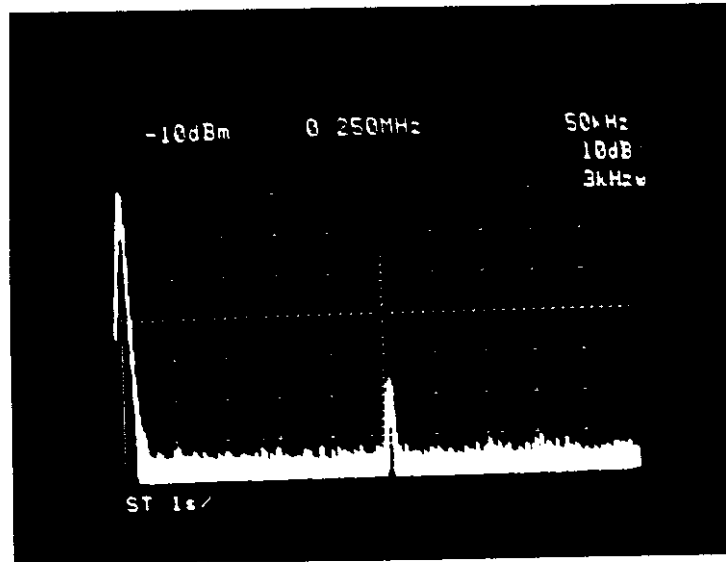

Medium
Long Pulse

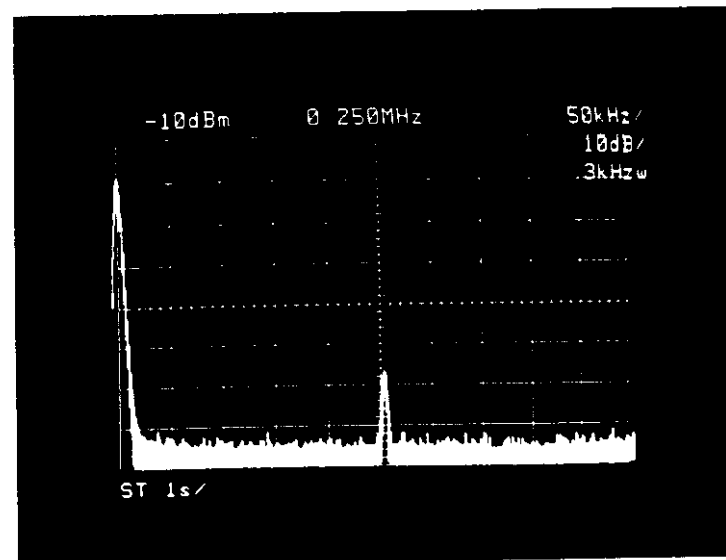

Long Pulse

TEST #2

Frequency Band: 0~5 MHz

Log Ref. Level: 18.0 dBm

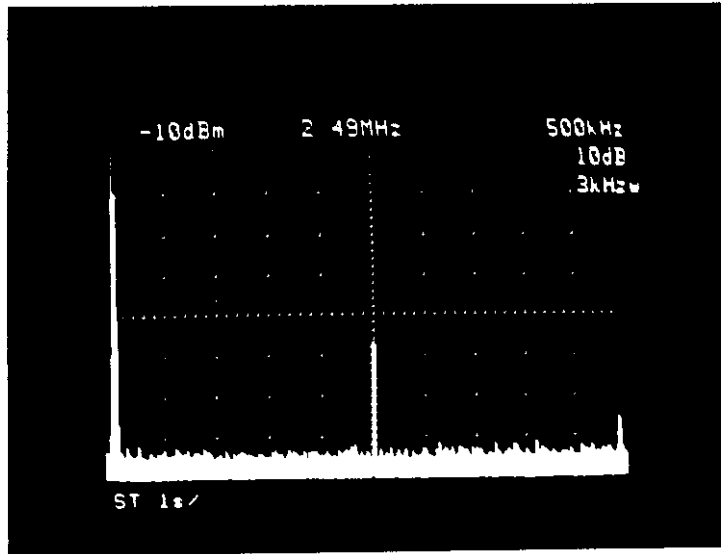

Ambient

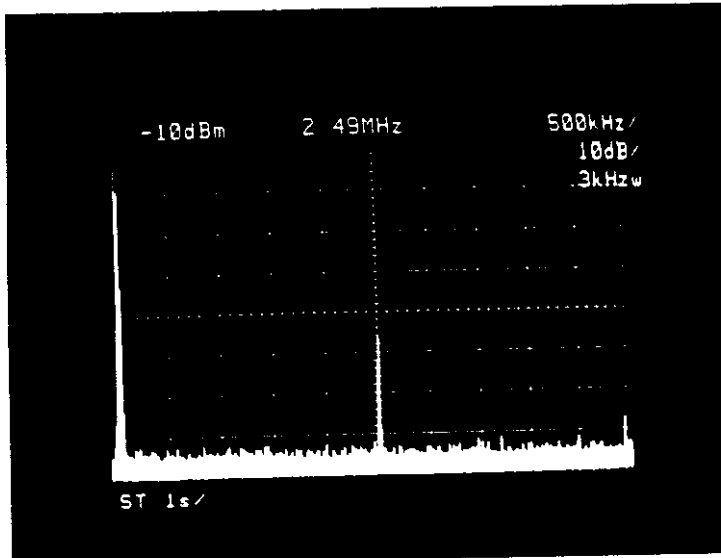

Stand-By

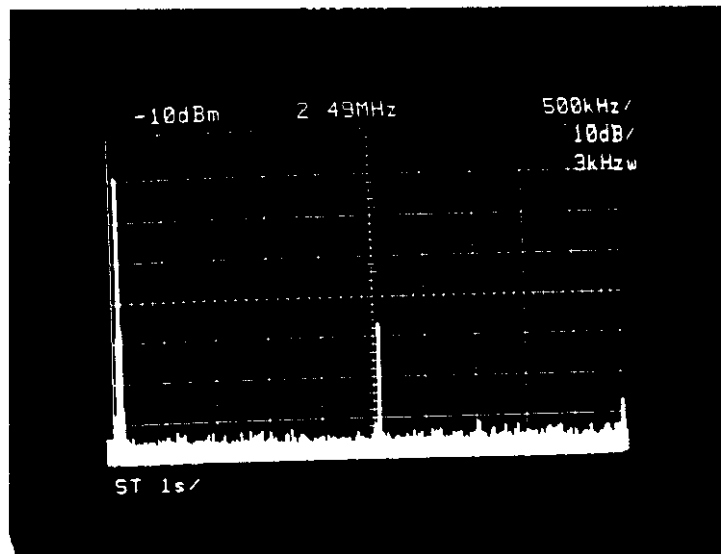

Short Pulse

TEST #2

Frequency Band: 0~5 MHz

Log Ref. Level: 18.0 dBm

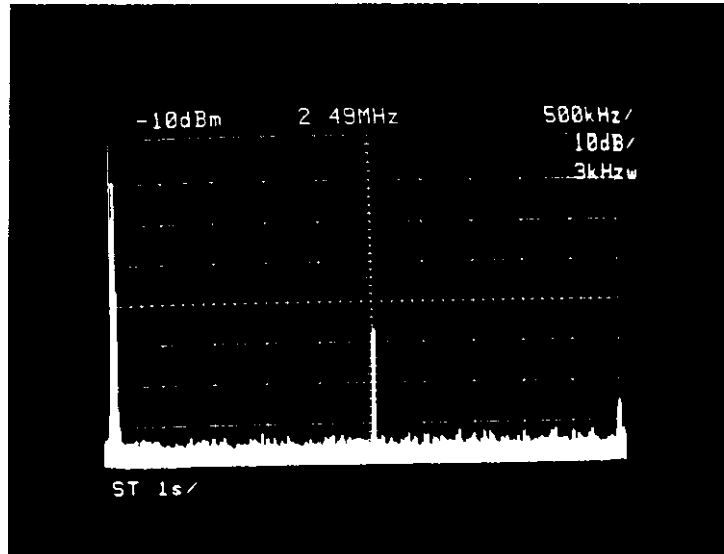

Medium
Short Pulse

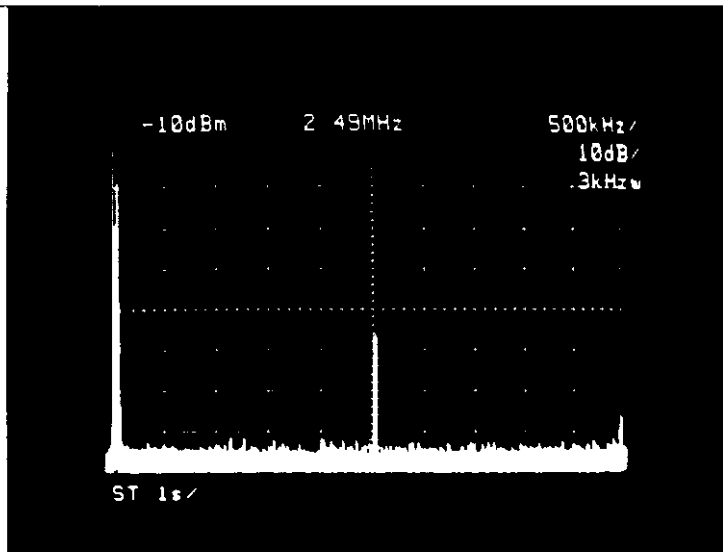

Medium
Long Pulse

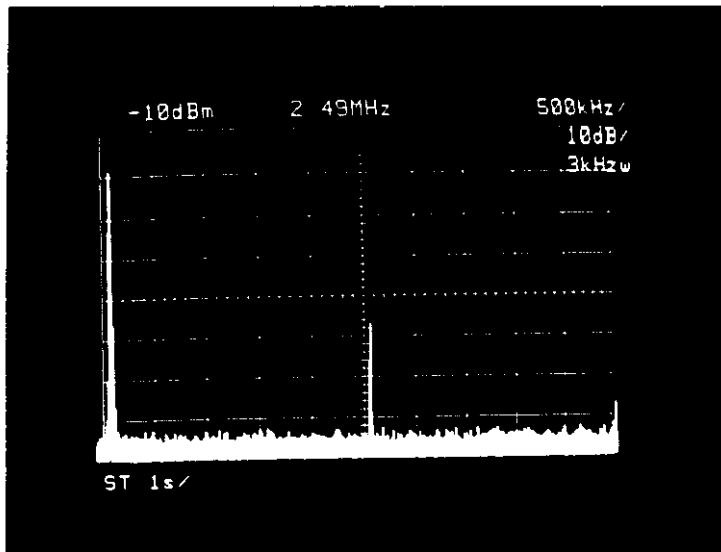

Long Pulse

TEST #3

Frequency Band: 0~50 MHz

Log Ref. Level: 4.0 dBm

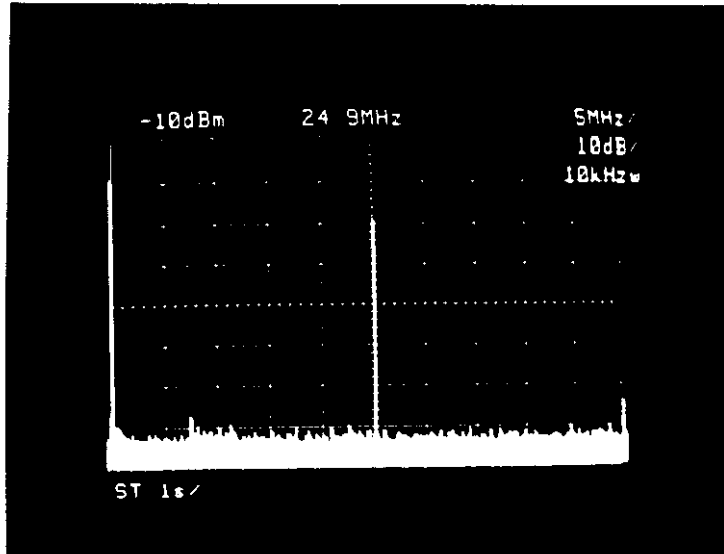

Ambient

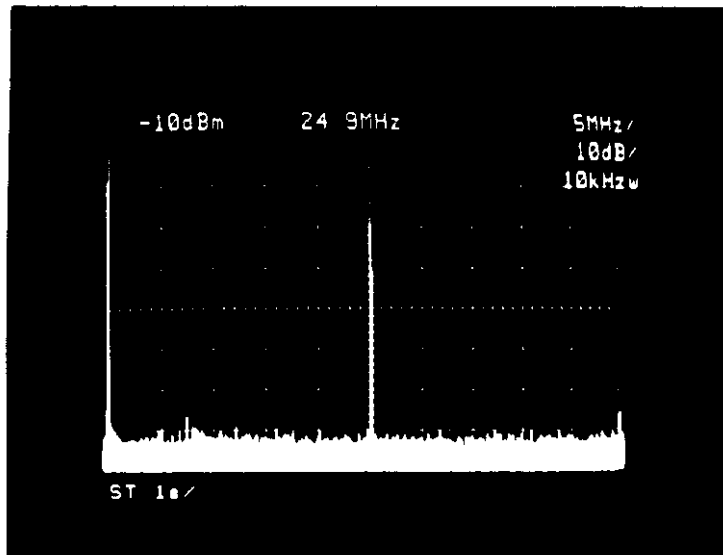

Stand-By

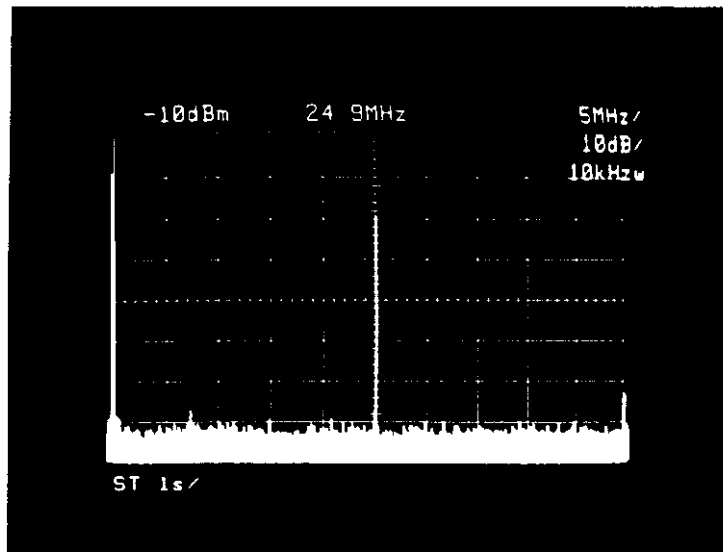

Short Pulse

TEST #3

Frequency Band: 0~50 MHz

Log Ref. Level: 4.0 dBm

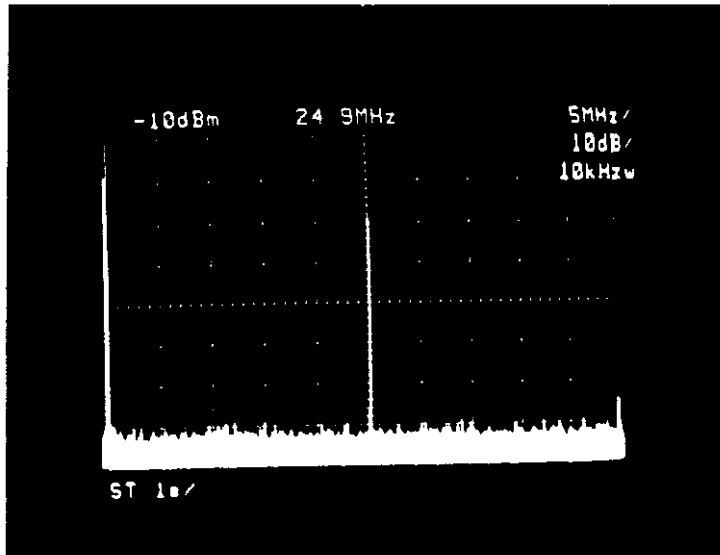

Medium
Short Pulse

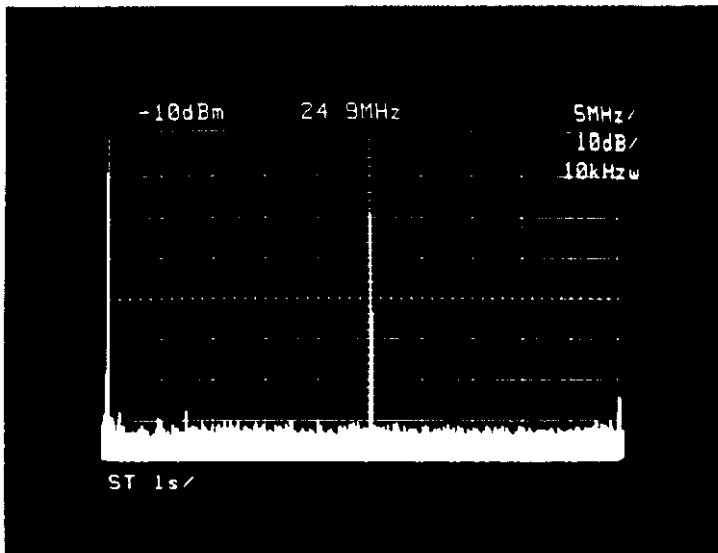

Medium
Long Pulse

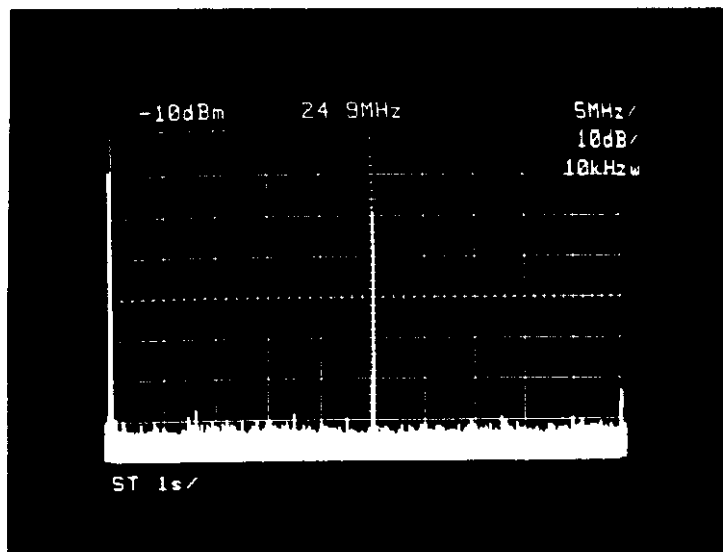

Long Pulse

TEST #4

Frequency Band: 0~500 MHz

Log Ref. Level: 1.0 dBm

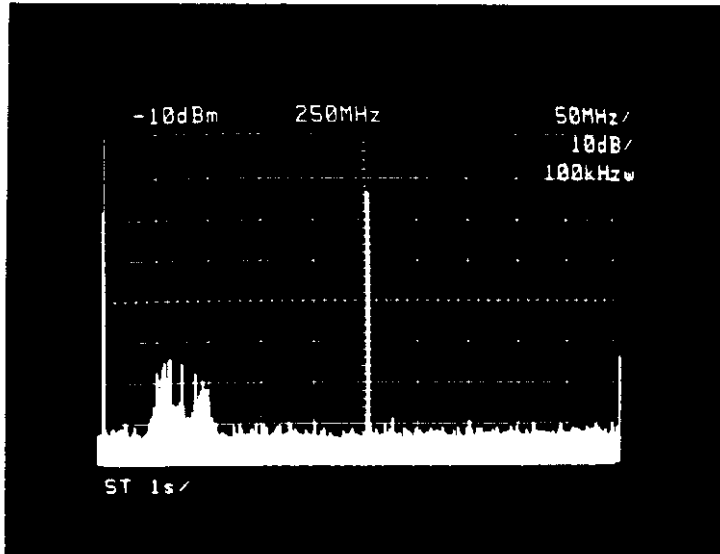

Ambient

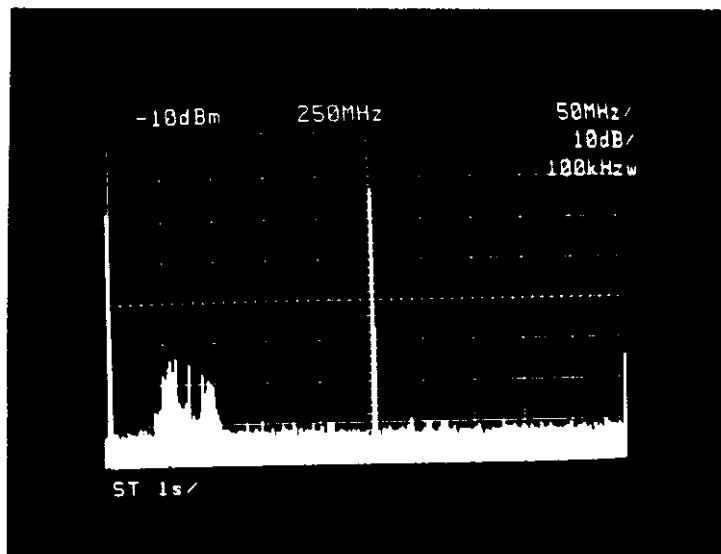

Stand-By

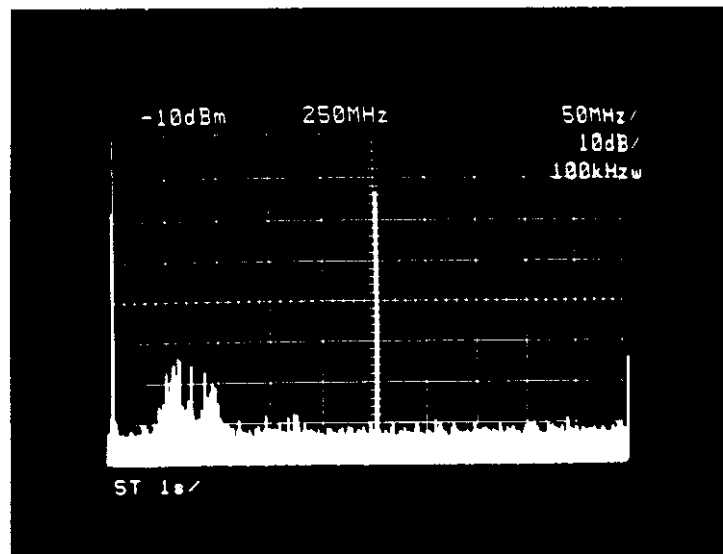

Short Pulse

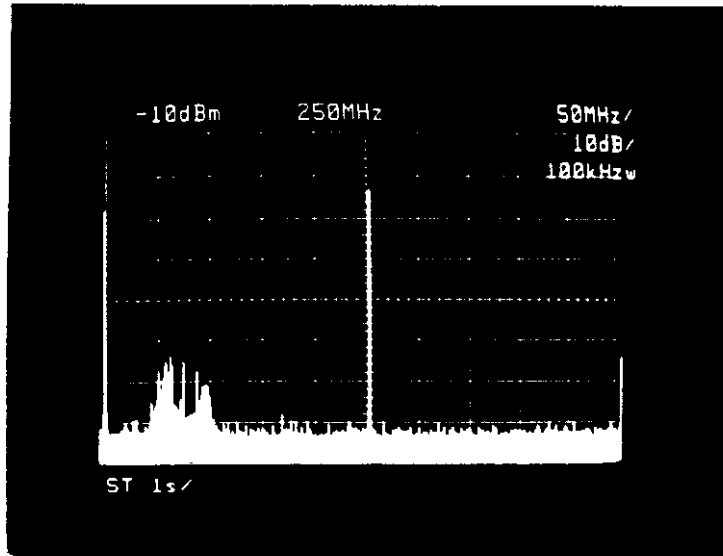

Medium
Short Pulse

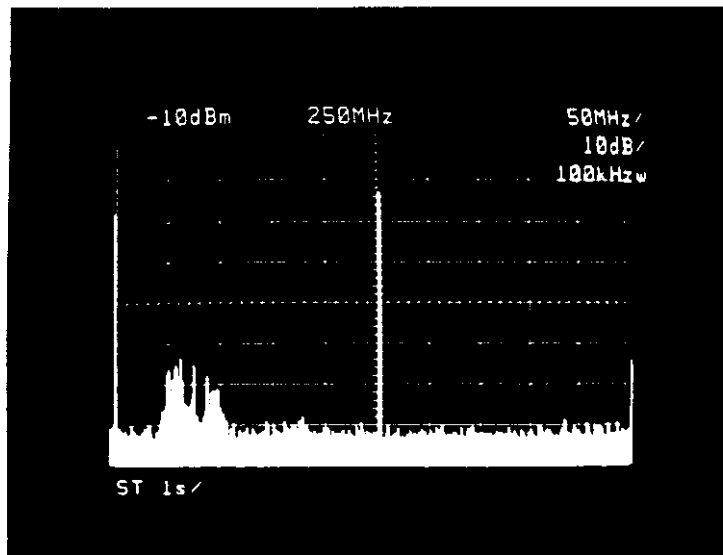

Medium
Long Pulse

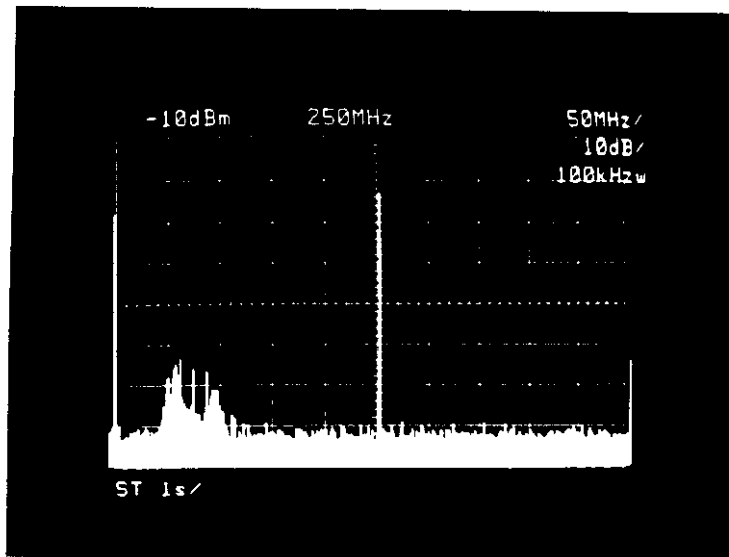

Long Pulse

TEST #5

Frequency Band: 0~1 GHz

Log Ref. Level: 4.0 dBm

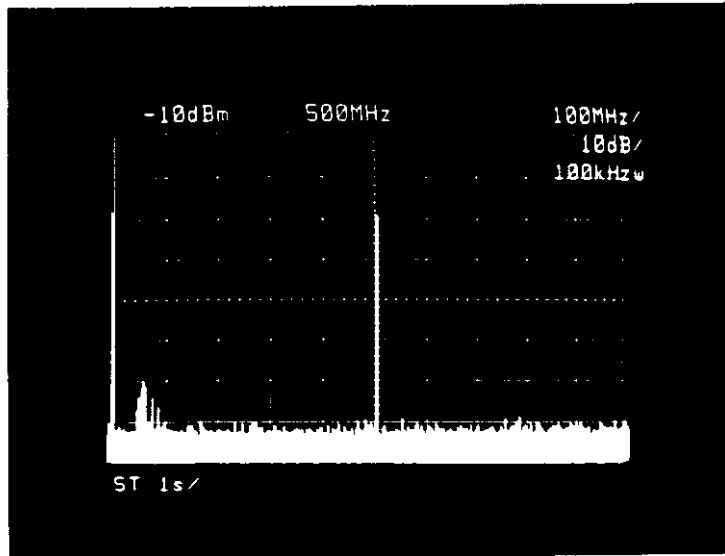

Ambient

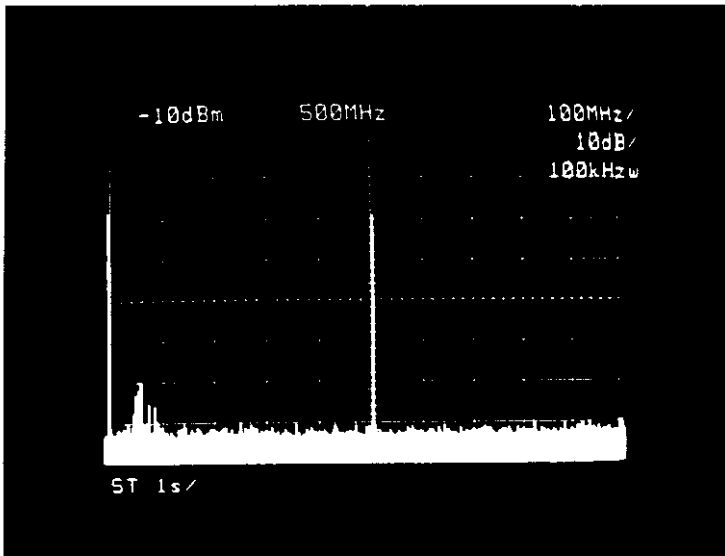

Stand-By

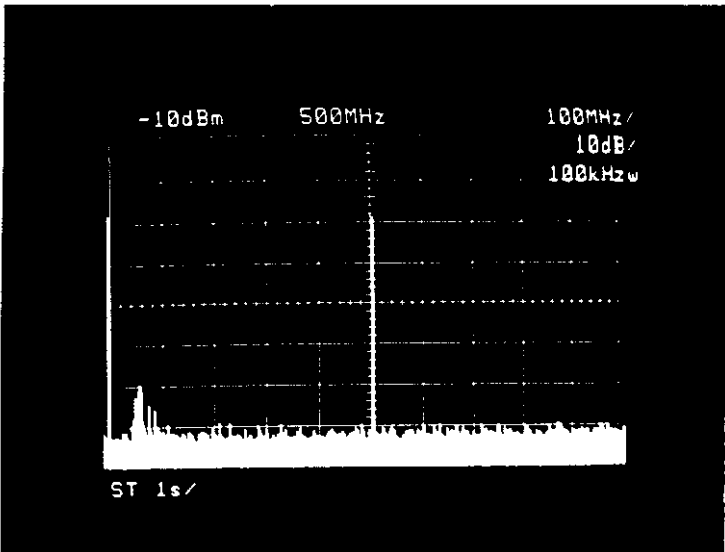

Short Pulse

TEST #5

Frequency Band: 0~1 GHz

Log Ref. Level: 4.0 dBm

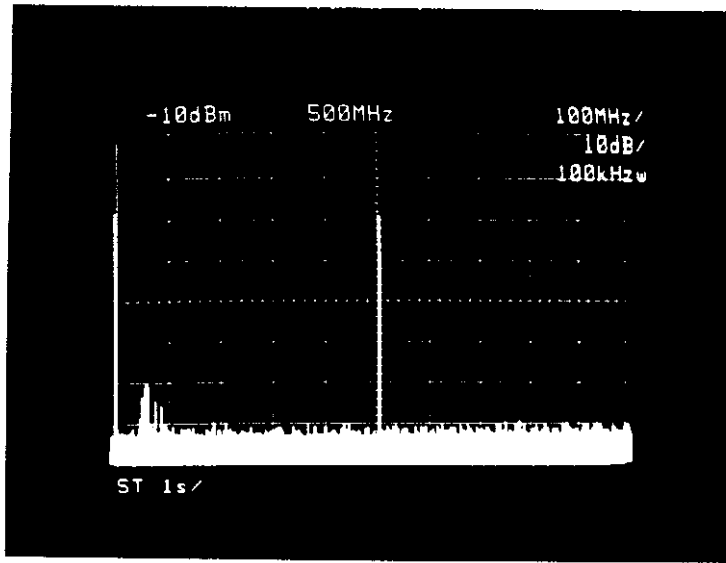

Medium
Short Pulse

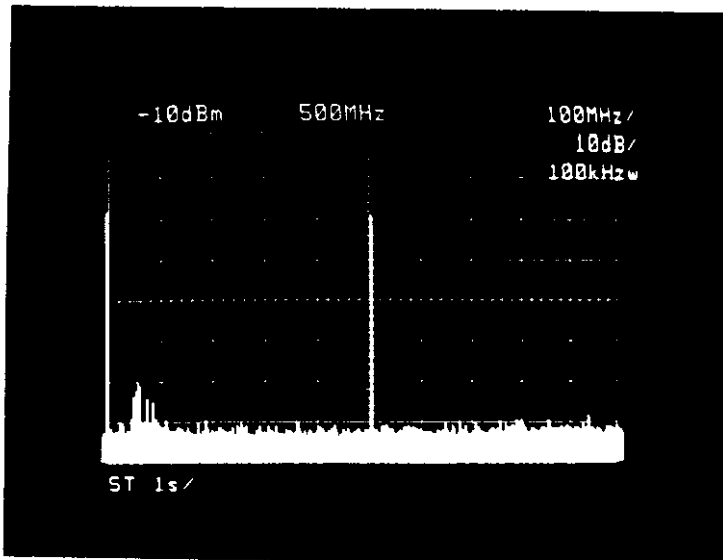

Medium
Pulse

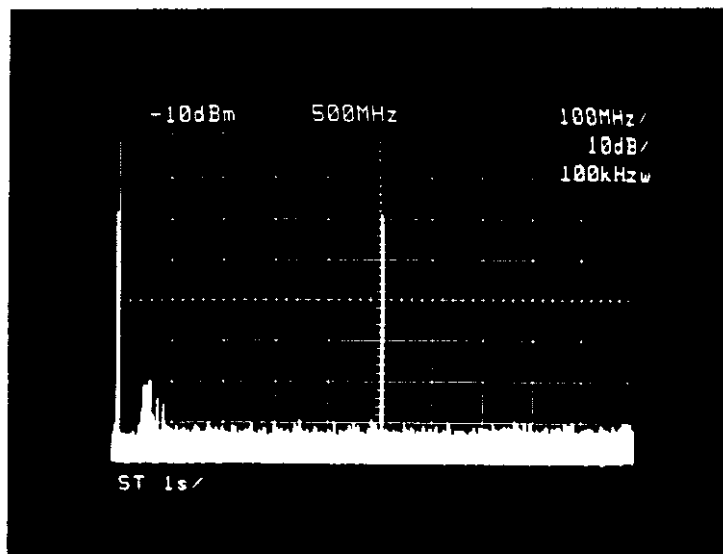

Long Pulse

CALIBRATION OF TESTS 6 ~ 10 (1 ~ 40 GHz)

Instead of using a signal source of known amplitude to calibrate the receiving system, the path and antenna characteristics were computed.

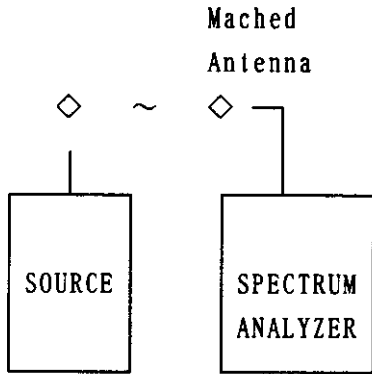

A half wave dipole was assumed to be the transmitting antenna.

(FCC 2.993)

The power density at distance R is:
$$P = \frac{1.64 P_t}{4 \pi R^2}$$

Where P_t is power transmitted.

The power to the analyzer is:
$$P_{sa} = P_{Ar} = \frac{P G \lambda^2}{4 \pi}$$

Where G is the receiving antenna gain and A_r is the effective area of the receiving antenna

Hence
$$P_{sa} = \frac{1.64 P_t}{4 \pi R^2} \times \frac{P G \lambda^2}{4 \pi} = \frac{1.6 G \lambda^2}{16 \pi^2} \times P_t \text{ at 1 meter}$$

and
$$P_t = \frac{16 \pi^2 P_{sa}}{1.64 G \lambda^2} = \frac{96.3 P_{sa}}{G \lambda^2}$$

$$= P_{sa} \text{ (dBm)} + 19.8 \text{ (dB)} - G \text{ (dB)} - 20 \log \lambda \text{ (dB)}$$

TEST	HORN GAIN (AVG) dB		WAVELENGTH (dB)		Pt - Psa		LOG REF LEVEL
	LOA	HI	LO	HI	LO	HI	
6	6		-10.5	-21.6	24.3	35.4	0 dBm
7	6		-21.3	-28.0	35.1	41.8	0 dBm
8	6		-27.6	-34.1	41.4	47.9	0 dBm
9	6		-31.2	-35.6	45.0	49.4	0 dBm
10	23.3	24.9	-35.6	-38.8	32.1	33.7	0 dBm
11	23.6	25.1	-39.4	-42.5	35.6	37.2	0 dBm

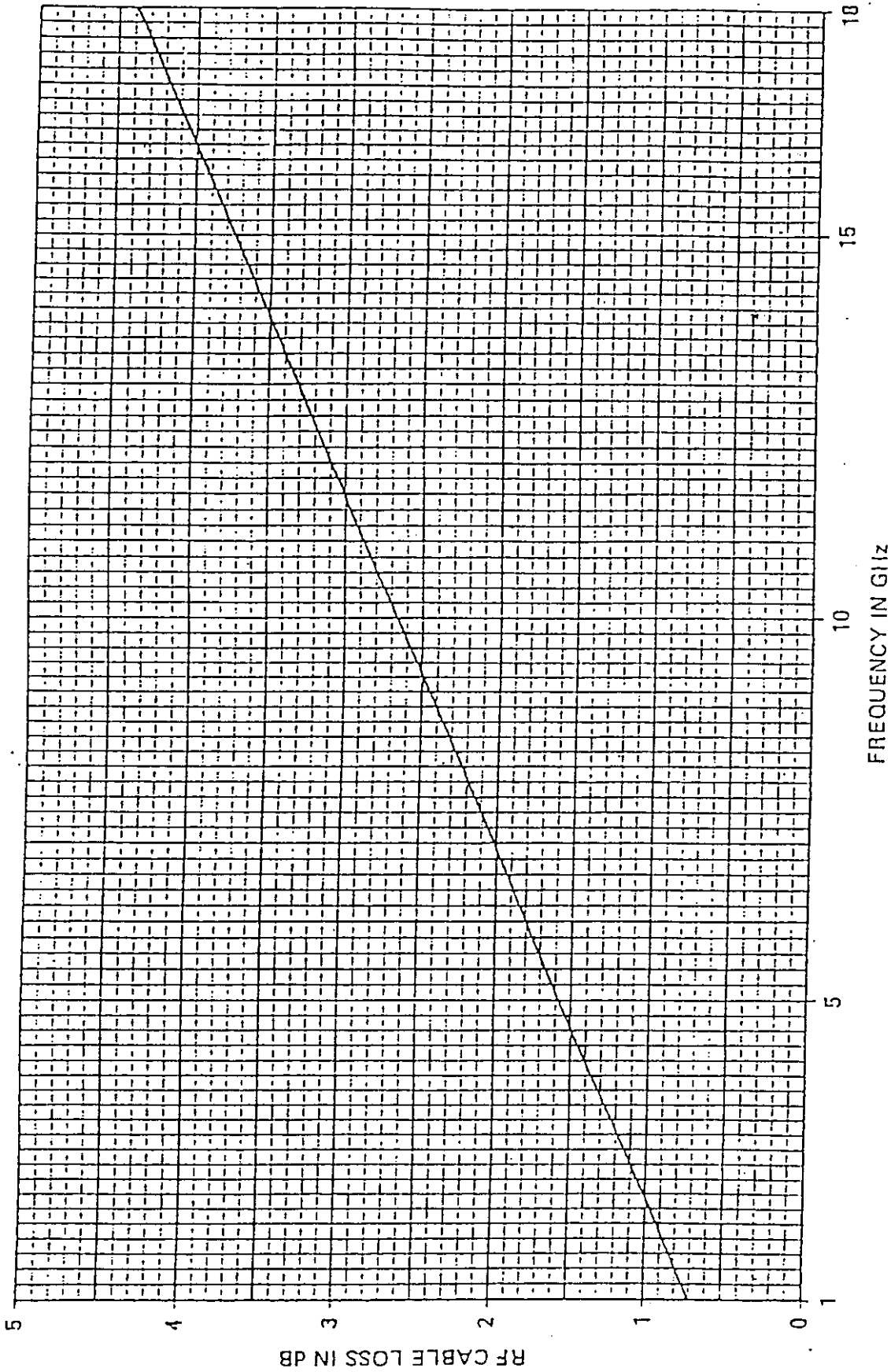

Figure 4-2. Model 94615-1 RF Cable Loss Chart

EATON

TITLE Model 94612-1 Log. Periodic Antenna
Instructions

DWG NO.

1-500783-364
SHEET 4 OF 6

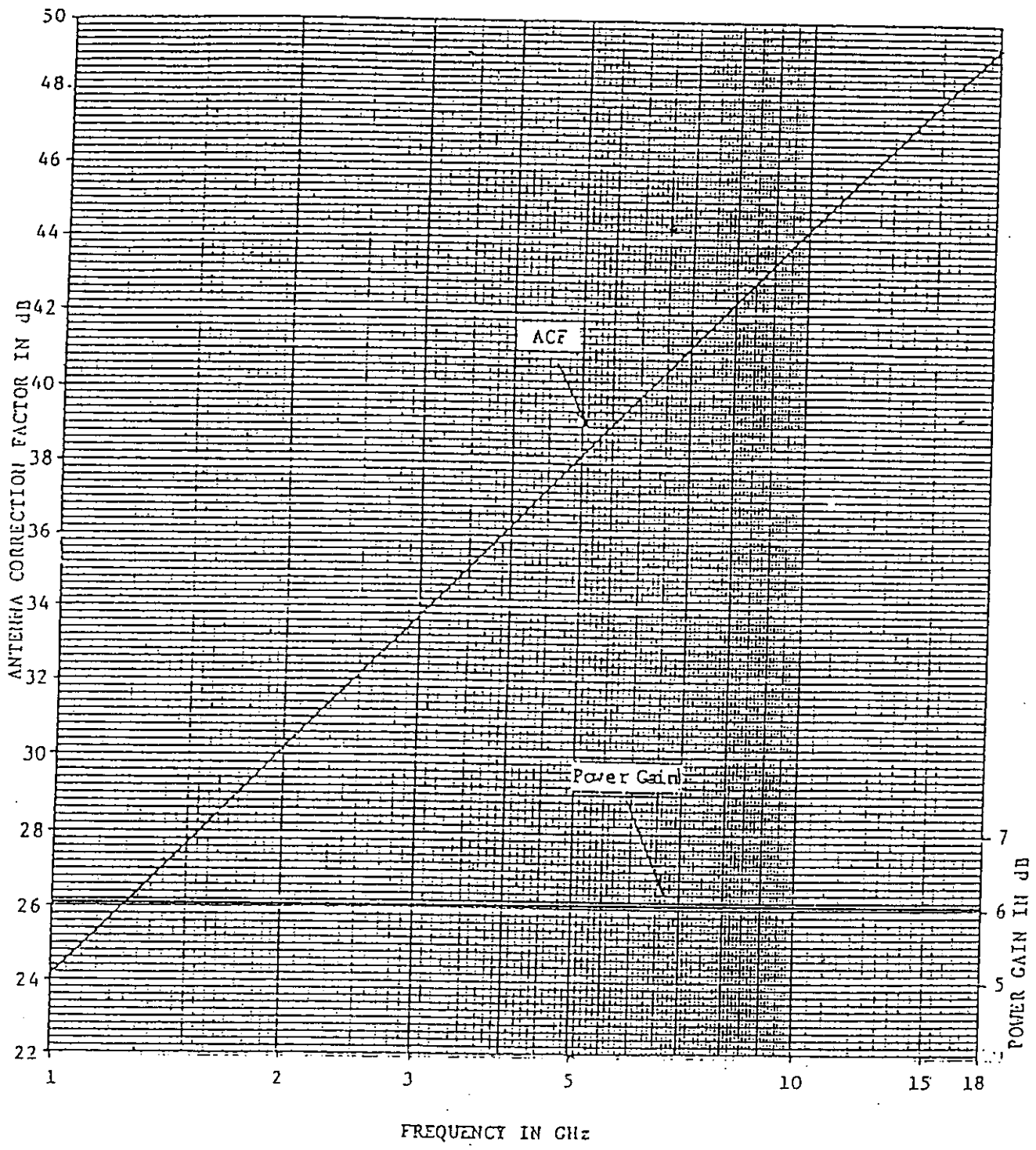

Figure 4-1. Antenna Correction Factor and Power Gain, Model 94612-1 Antenna



TITLE Model 94612-1 Log Periodic Antenna Instructions

DWG NO. 1- 500783-344
SHEET 3 OF 6

Power Gain in dB

Antenna Correction Factor in dB

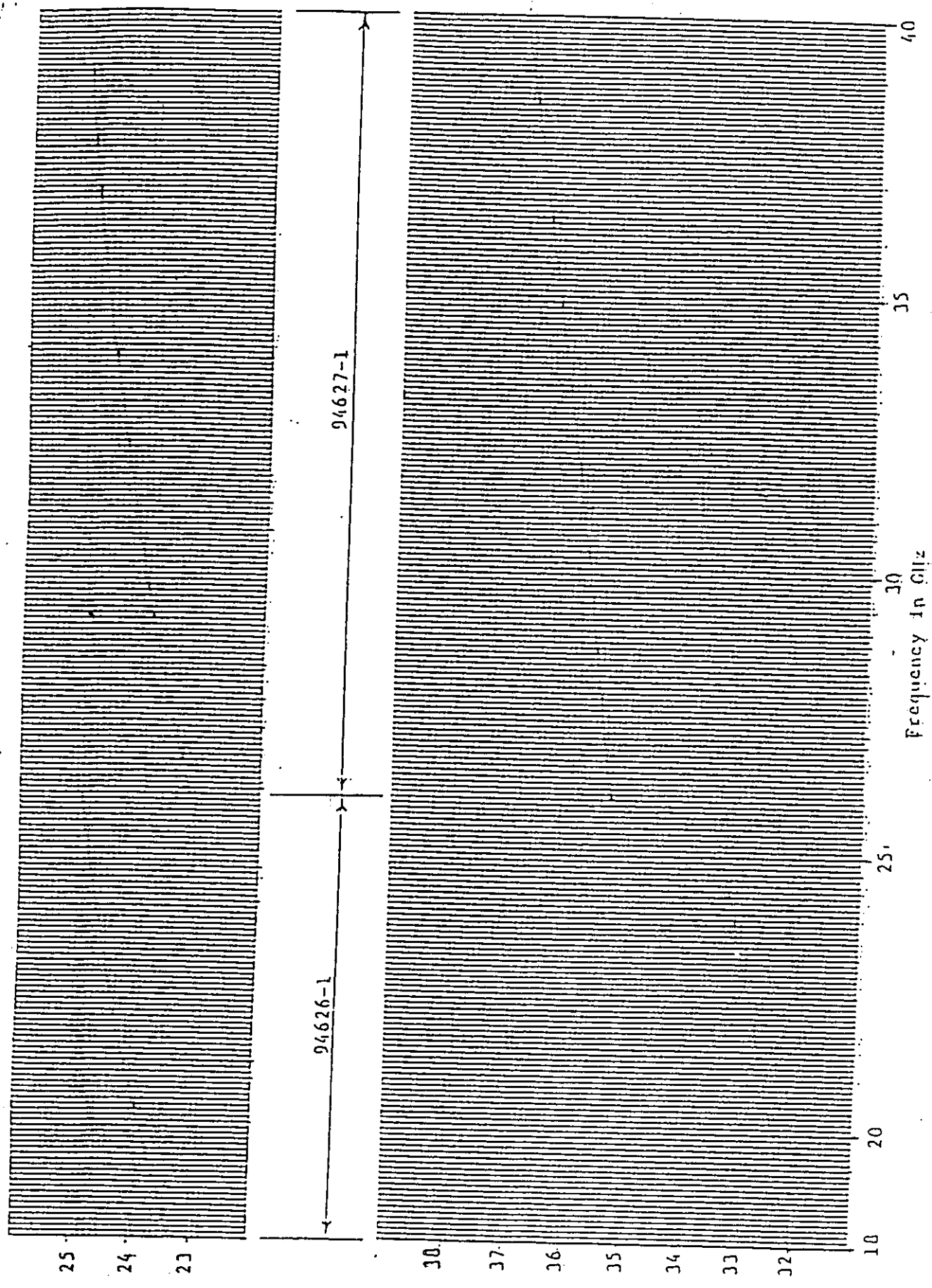

Figure 1-1. Antenna Correction Factor and Power Gain for Hott Antenna

TEST #6

Frequency Band: 1~3.6 GHz

Log Ref. Level: 0 dBm

Maximum Spurious Signal Observed: (See Calibration Procedure
for Test 6~11)

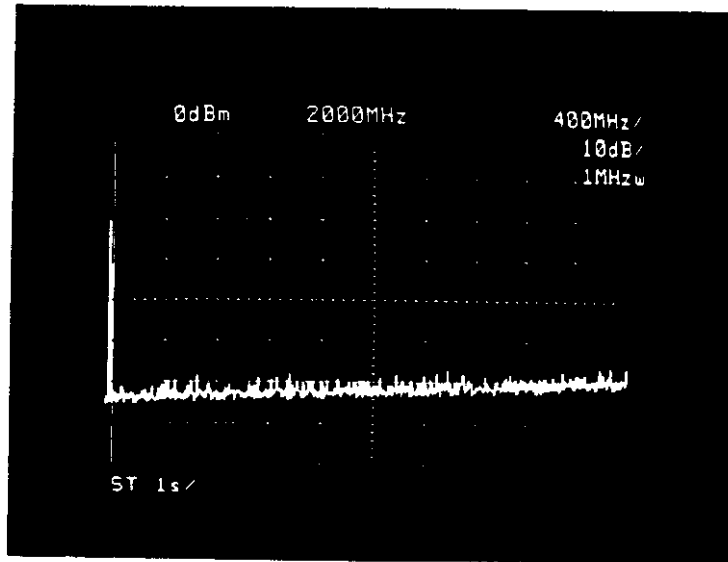

AMBIENT

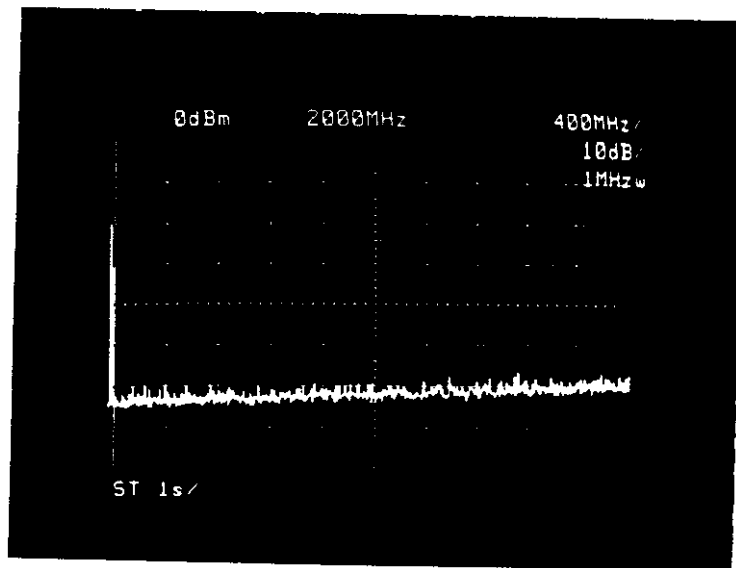

STANDBY

TEST #6

Frequency Band: 1~3.6 GHz

Log Ref. Level: 0 dBm

Maximum Spurious Signal Observed: (See Calibration Procedure
for Test 6~11)

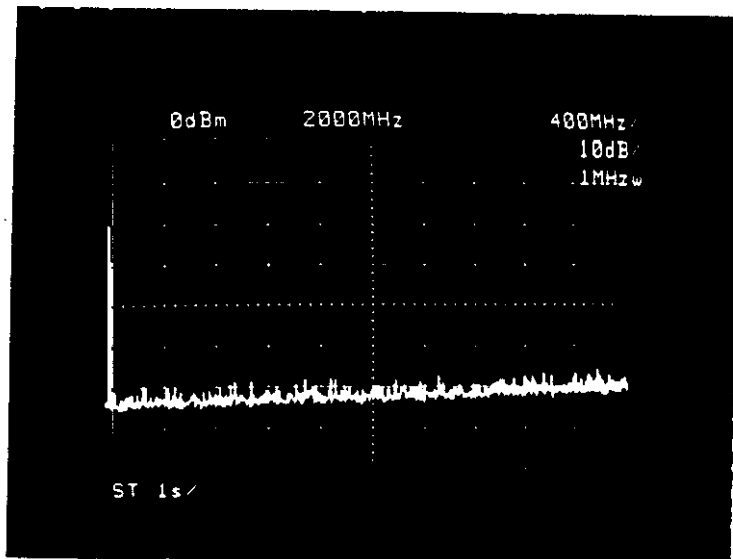

SHORT PULSE

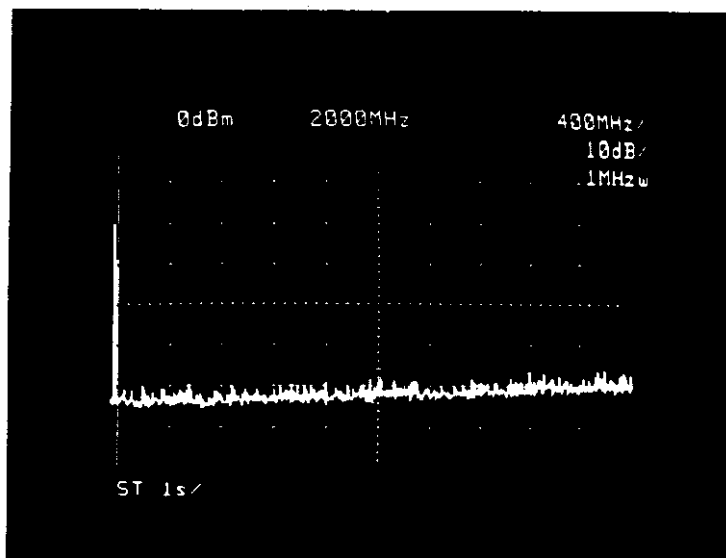

MEDIUM
SHORT PULSE

TEST #6

Frequency Band: 1~3.6 GHz

Log Ref. Level: 0 dBm

Maximum Spurious Signal Observed: (See Calibration Procedure
for Test 6~11)

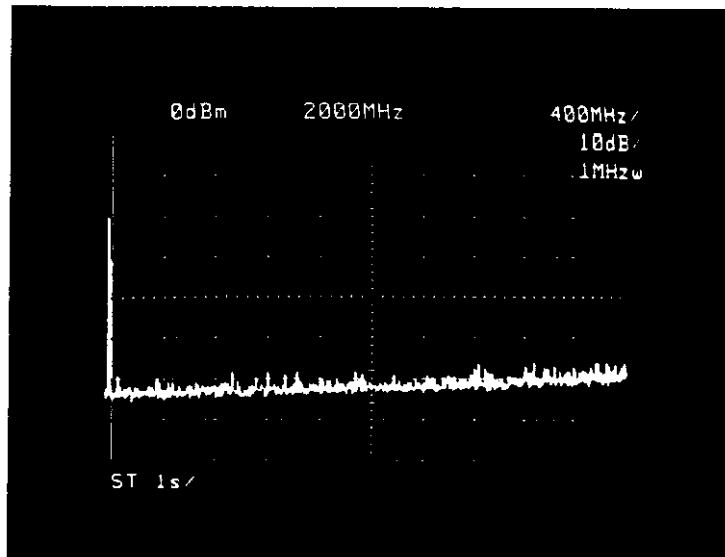

MEDIUM
LONG PULSE

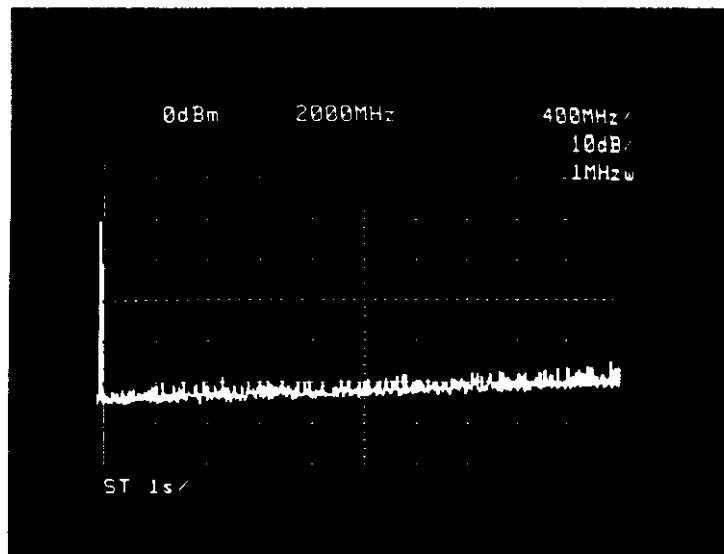

LONG PULSE

TEST #7

Frequency Band: 3.5~7.5 GHz

Log Ref. Level: 0 dBm

Maximum Spurious Signal Observed: (See Calibration Procedure
for Test 6~11)

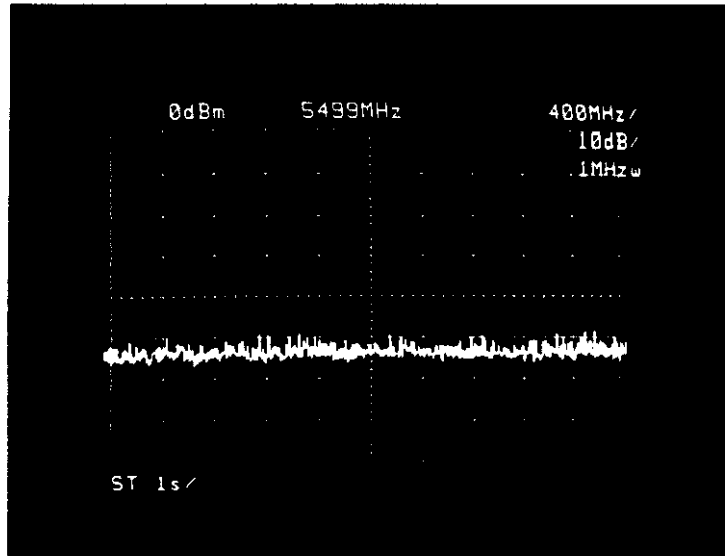

AMBIENT

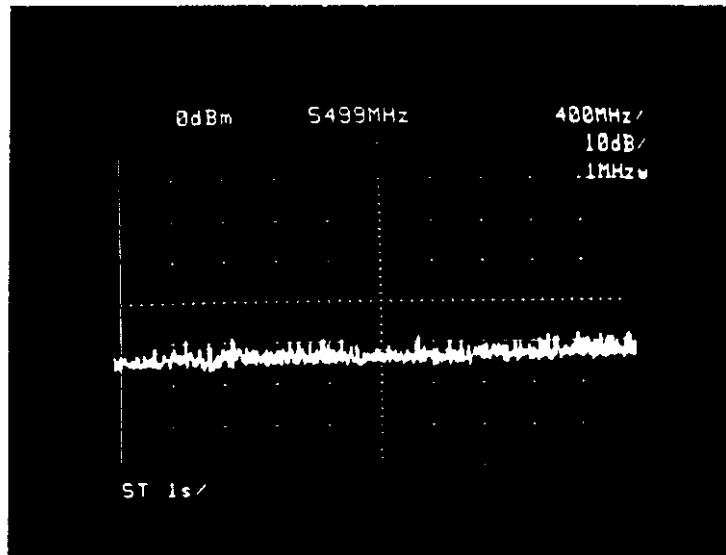

STANDBY

TEST #7

Frequency Band: 3.5~7.5 GHz

Log Ref. Level: 0 dBm

Maximum Spurious Signal Observed: (See Calibration Procedure
for Test 6~11)

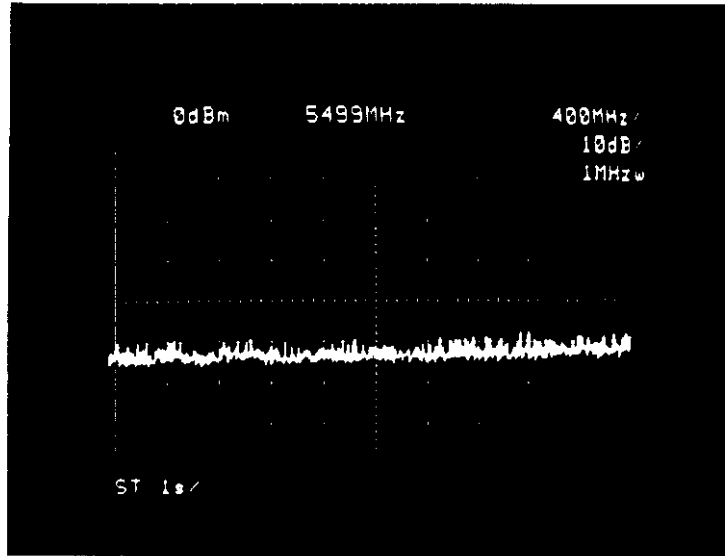

SHORT PULSE

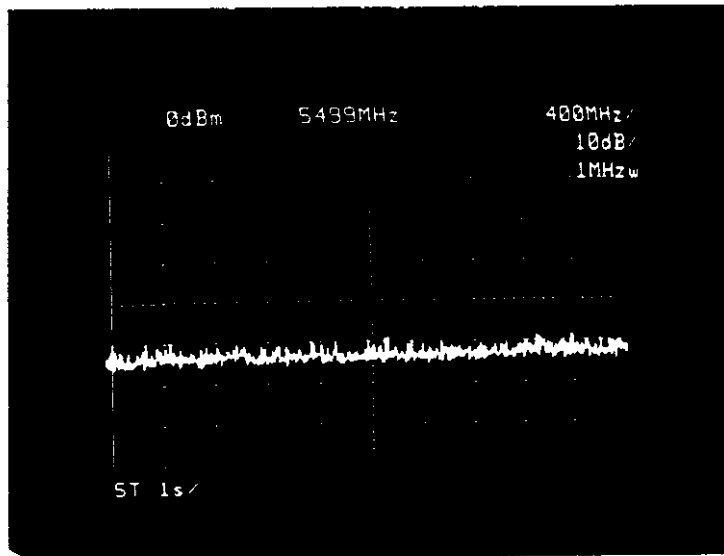

MEDIUM
SHORT PULSE

TEST #7

Frequency Band: 3.5~7.5 GHz

Log Ref. Level: 0 dBm

Maximum Spurious Signal Observed: (See Calibration Procedure
for Test 6~11)

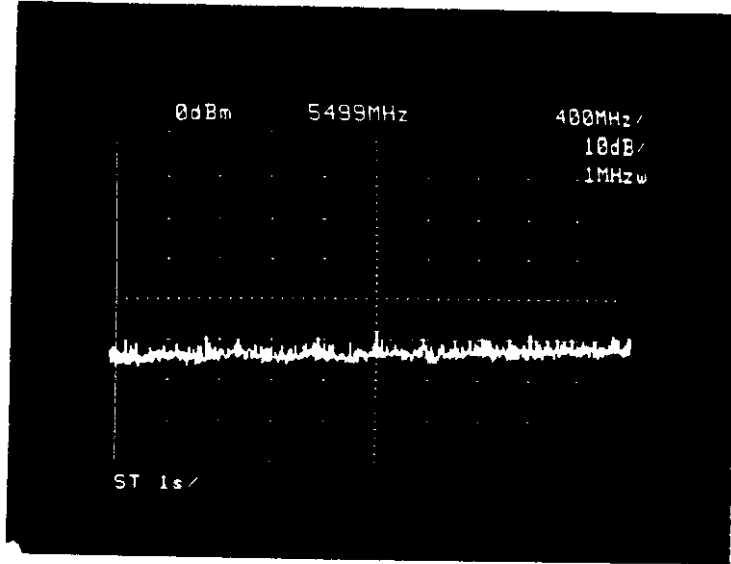

MEDIUM
LONG PULSE

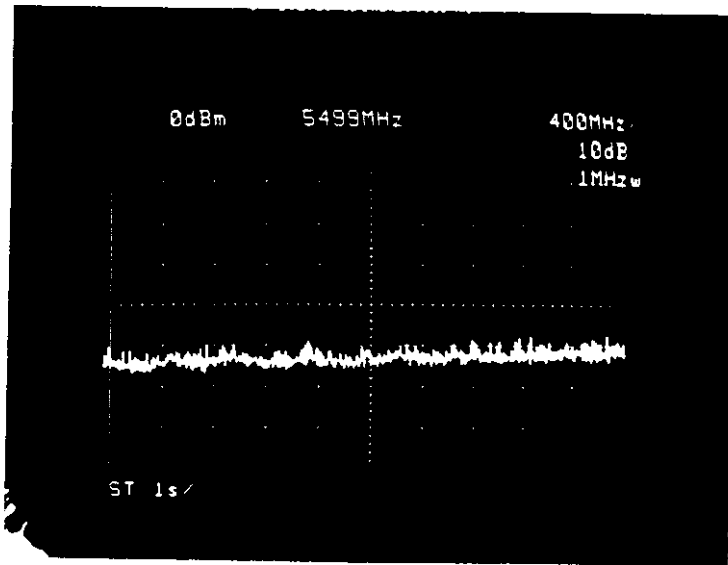

LONG PULSE

TEST #8

Frequency Band: 7~11 GHz

Log Ref. Level: 0 dBm

Maximum Spurious Signal Observed: (See Calibration Procedure
for Test 6~11)

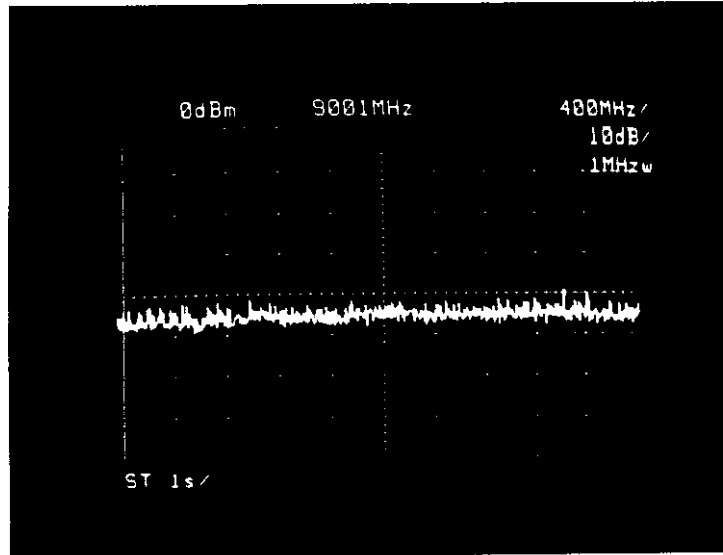

AMBIENT

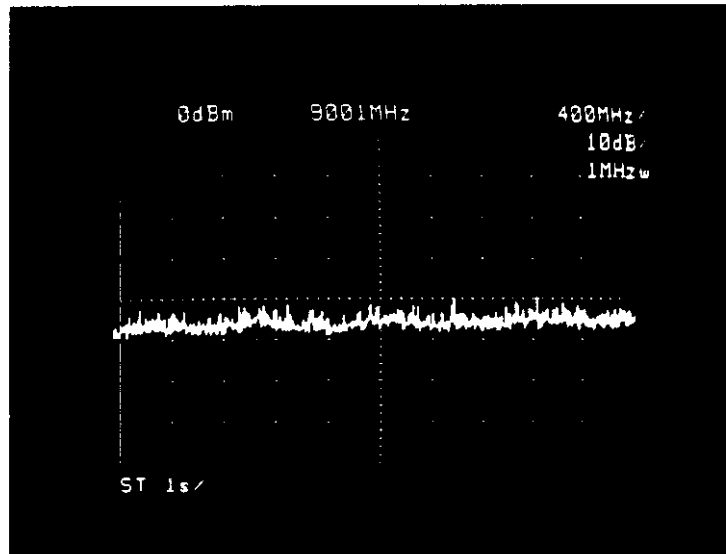

STANDBY

TEST #8

Frequency Band: 7~11 GHz

Log Ref. Level: 0 dBm

Maximum Spurious Signal Observed: (See Calibration Procedure
for Test 6~11)

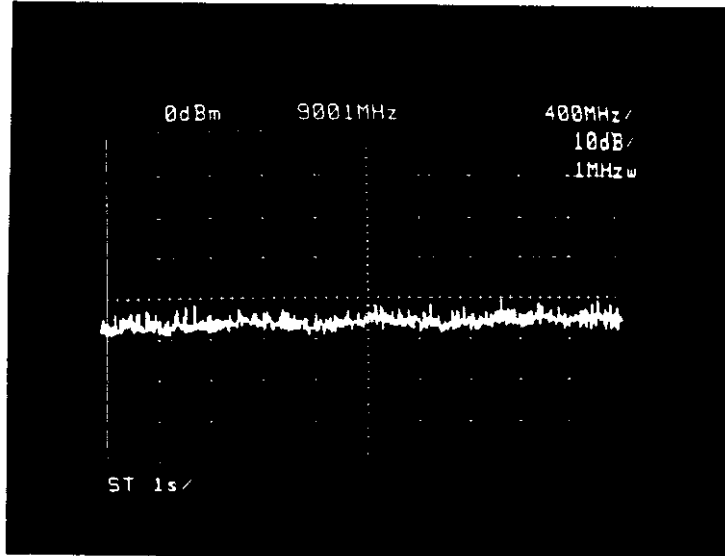

SHORT PULSE

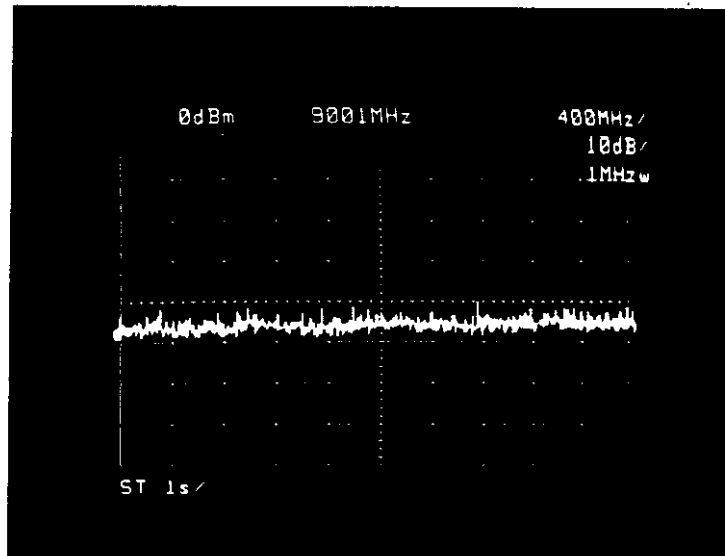

MEDIUM
SHORT PULSE

TEST #8

Frequency Band: 7~11 GHz

Log Ref. Level: 0 dBm

Maximum Spurious Signal Observed: (See Calibration Procedure
for Test 6~11)

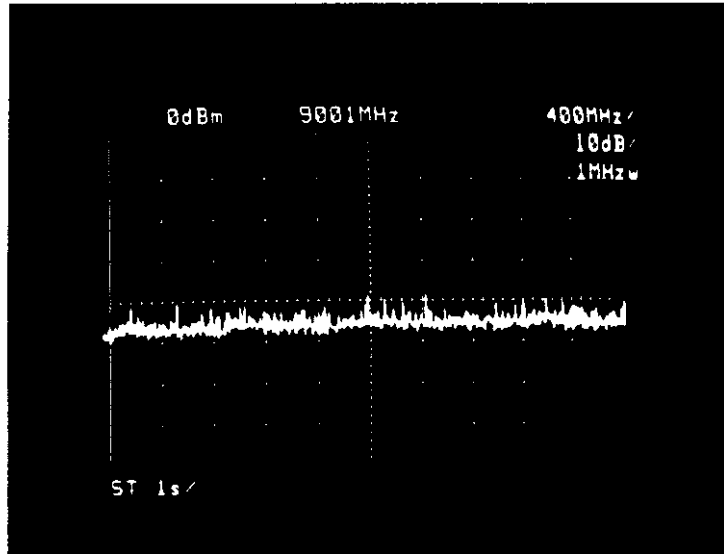

MEDIUM
LONG PULSE

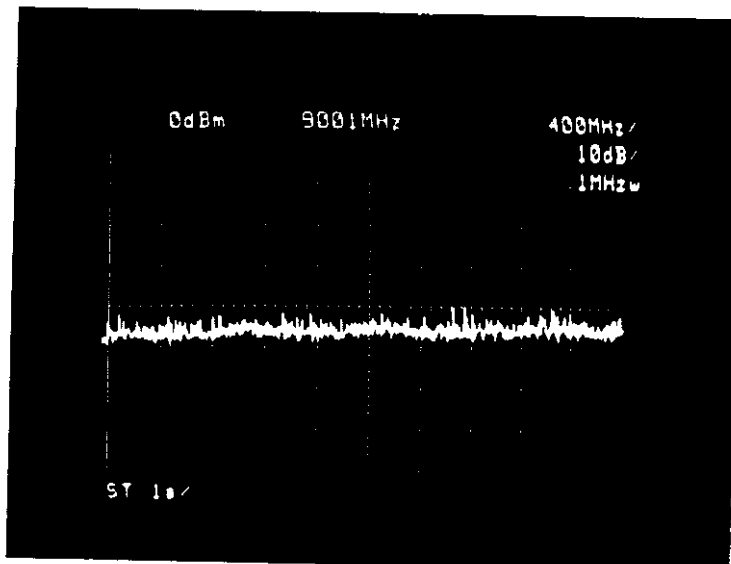

LONG PULSE

TEST #9

Frequency Band: 10.9~20 GHz

Log Ref. Level: 0 dBm

Maximum Spurious Signal Observed: (See Calibration Procedure
for Test 6~11)

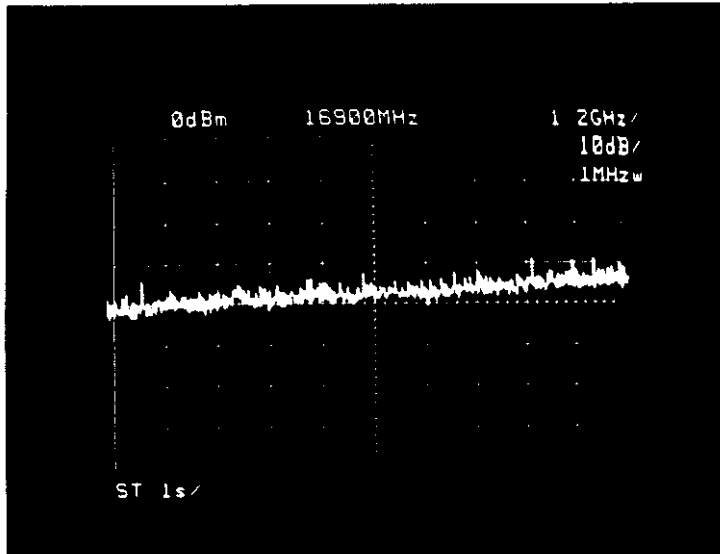

AMBIENT

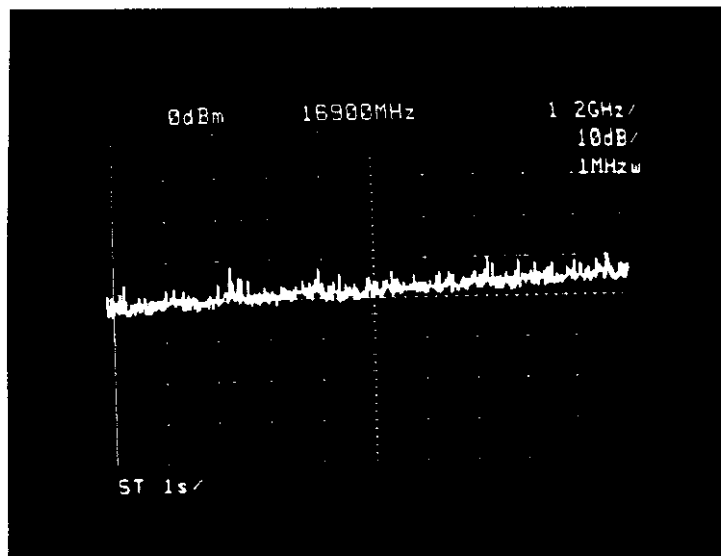

STANDBY

TEST #9

Frequency Band: 10.9~20 GHz

Log Ref. Level: 0 dBm

Maximum Spurious Signal Observed: (See Calibration Procedure
for Test 6~11)

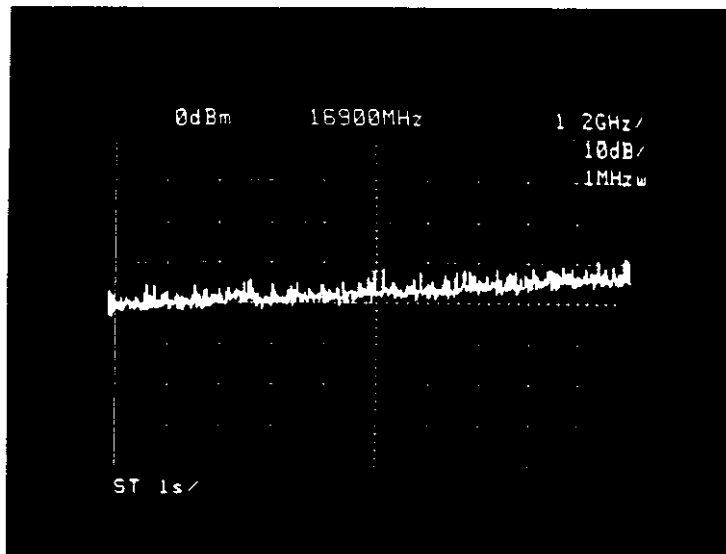

SHORT PULSE

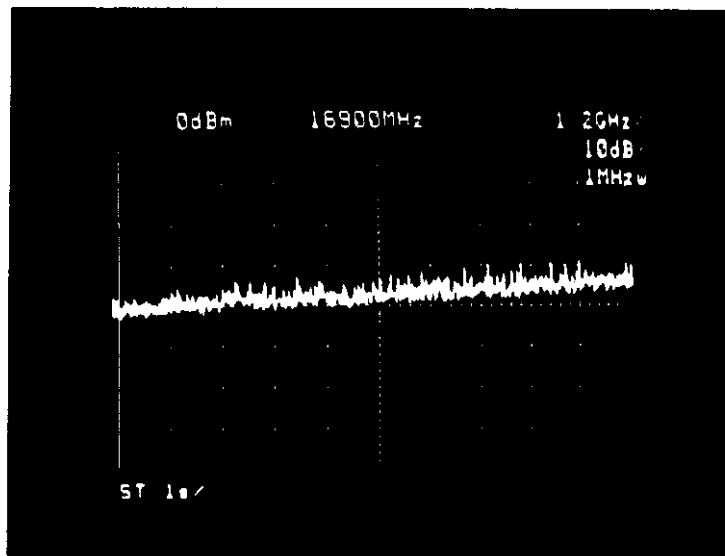

MEDIUM
SHORT PULSE

TEST #9

Frequency Band: 10.9~20 GHz

Log Ref. Level: 0 dBm

Maximum Spurious Signal Observed: (See Calibration Procedure
for Test 6~11)

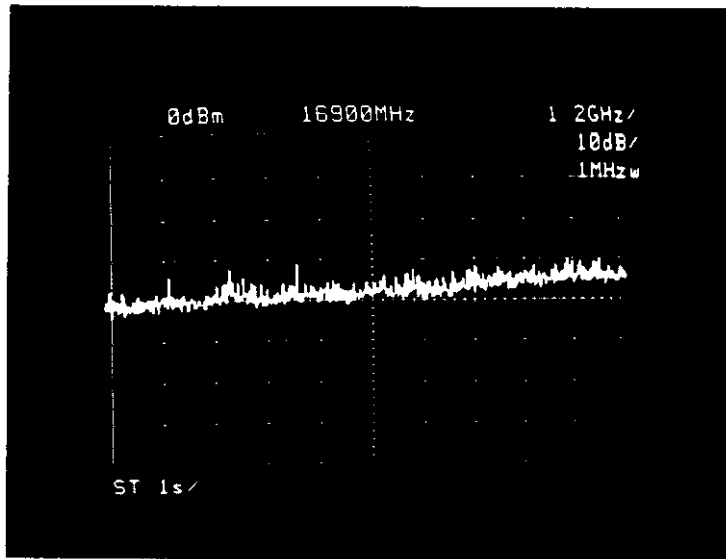

MEDIUM
LONG PULSE

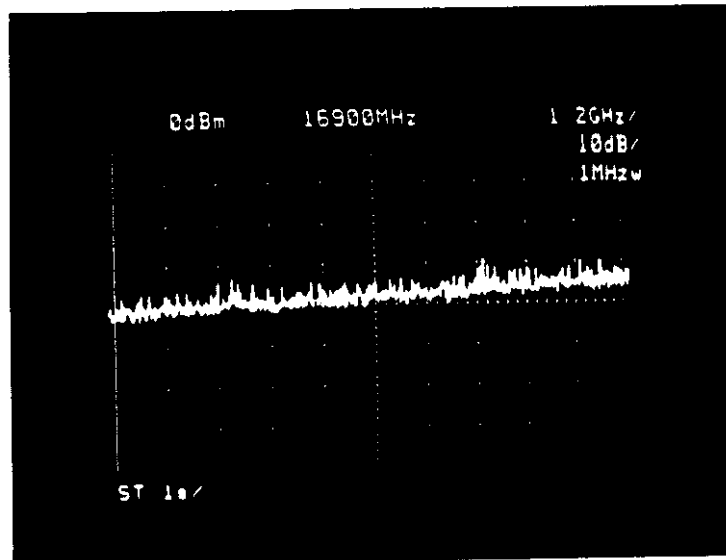

LONG PULSE

TEST #10

Frequency Band: 12.4~28 GHz

Log Ref. Level: 0 dBm

Maximum Spurious Signal Observed: (See Calibration Procedure
for Test 6~11)

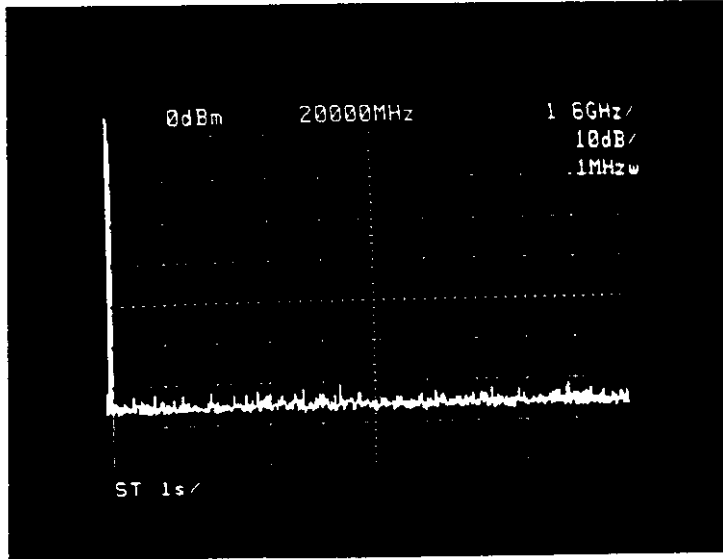

AMBIENT

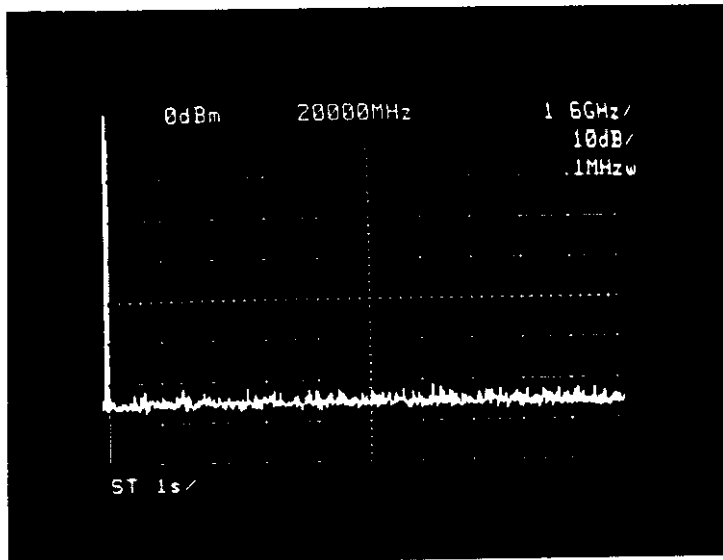

STANDBY

TEST #10

Frequency Band: 12.4~28 GHz

Log Ref. Level: 0 dBm

Maximum Spurious Signal Observed: (See Calibration Procedure
for Test 6~11)

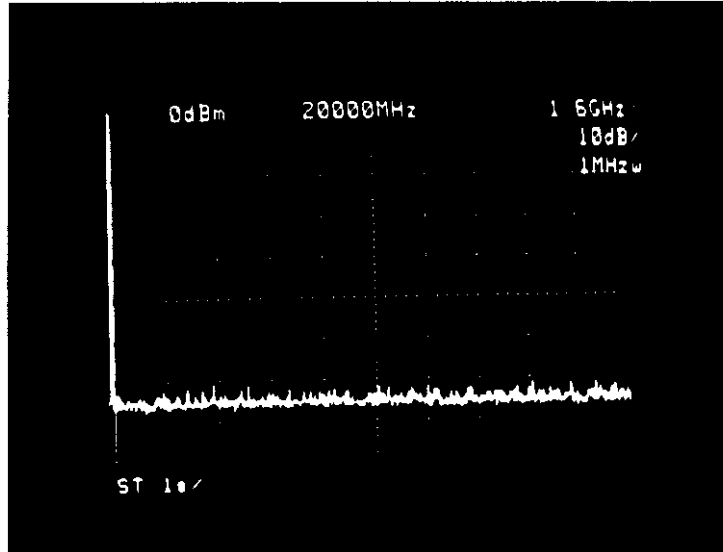

SHORT PULSE

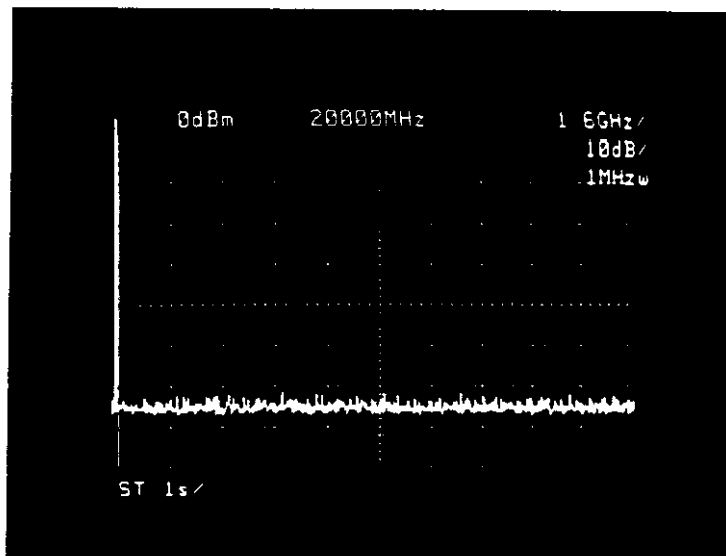

MEDIUM
SHORT PULSE

TEST #10

Frequency Band: 12.4~28 GHz

Log Ref. Level: 0 dBm

Maximum Spurious Signal Observed: (See Calibration Procedure
for Test 6~11)

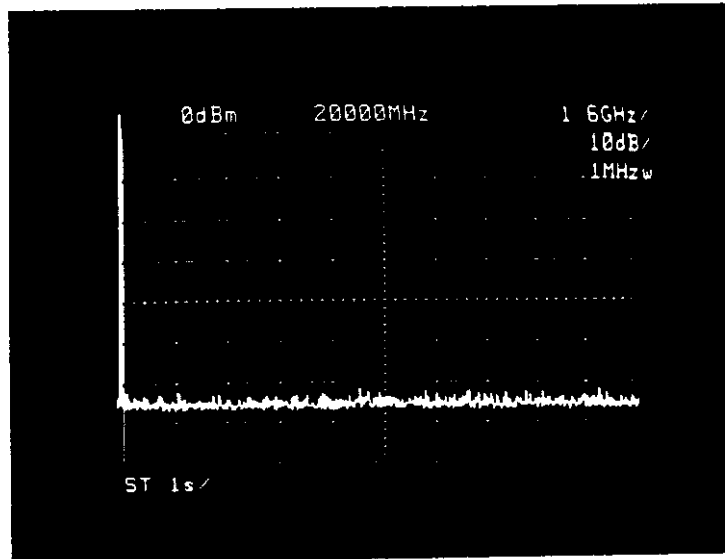

MEDIUM
LONG PULSE

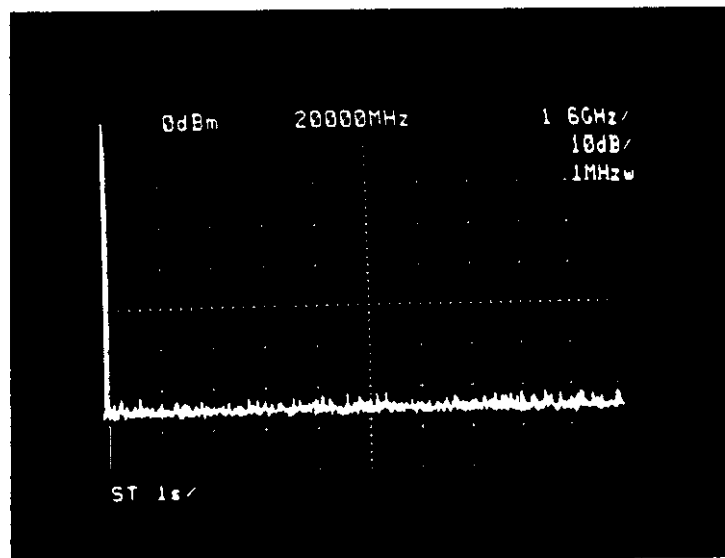

LONG PULSE

TEST #11

Frequency Band: 28~60 GHz

Log Ref. Level: 0 dBm

Maximum Spurious Signal Observed: (See Calibration Procedure
for Test 6~11)

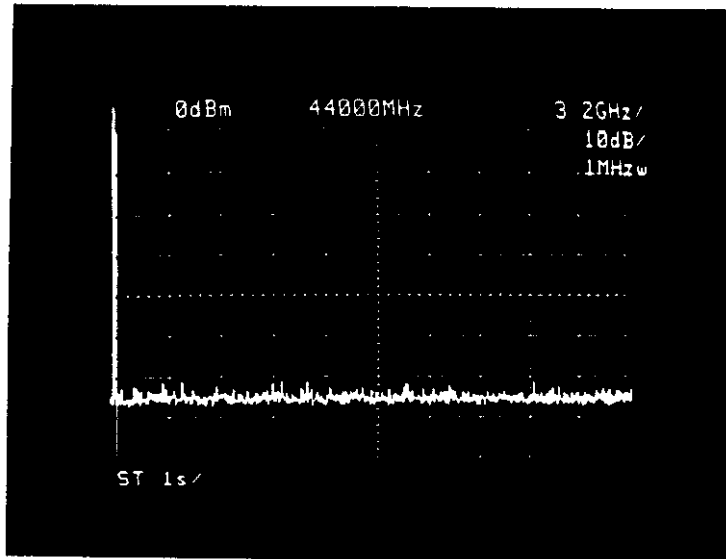

AMBIENT

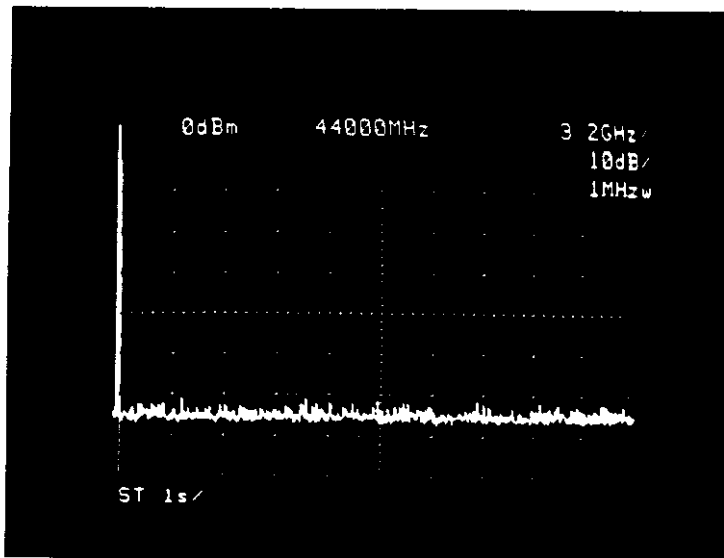

STANDBY

TEST #11

Frequency Band: 28~60 GHz

Log Ref. Level: 0 dBm

Maximum Spurious Signal Observed: (See Calibration Procedure
for Test 6~11)

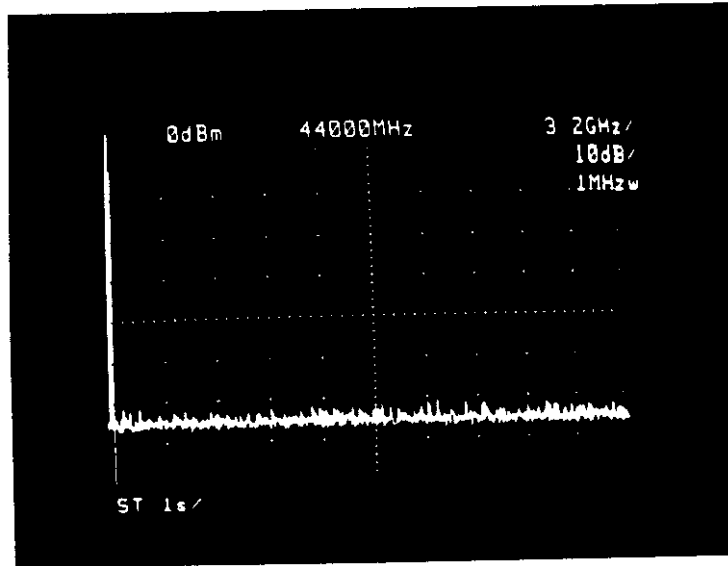

SHORT PULSE

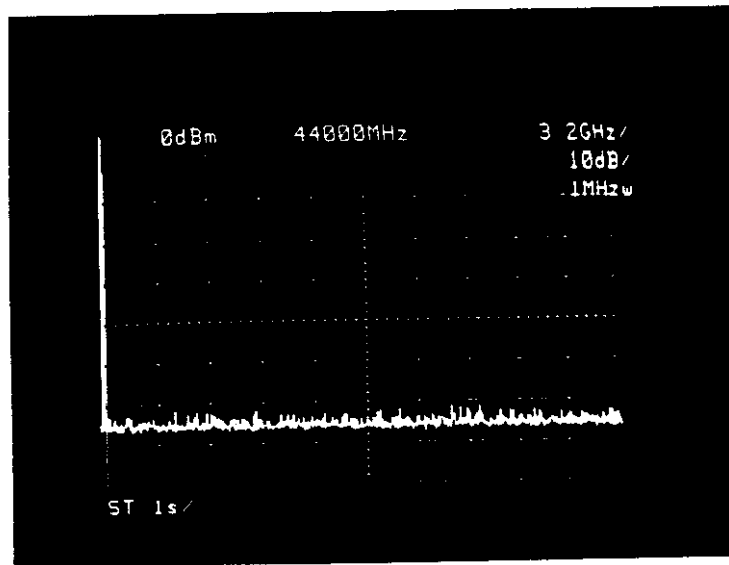

MEDIUM
SHORT PULSE

TEST #11

Frequency Band: 28~60 GHz

Log Ref. Level: 0 dBm

Maximum Spurious Signal Observed: (See Calibration Procedure
for Test 6~11)

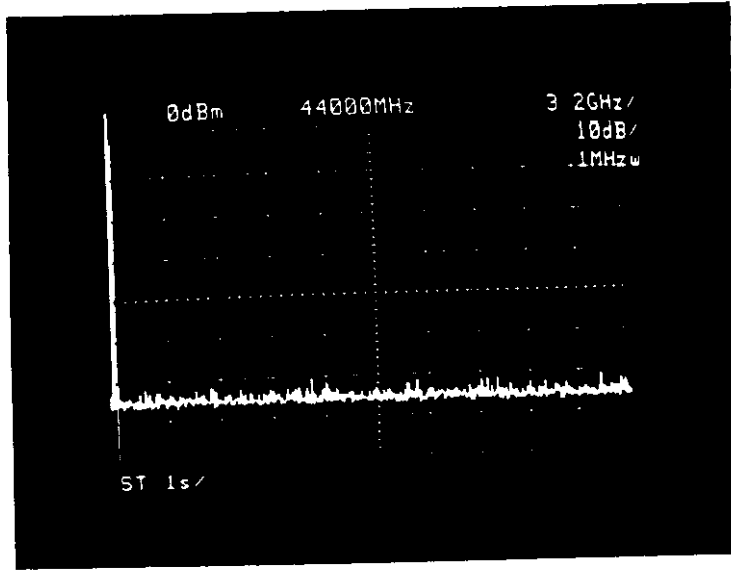

MEDIUM
LONG PULSE

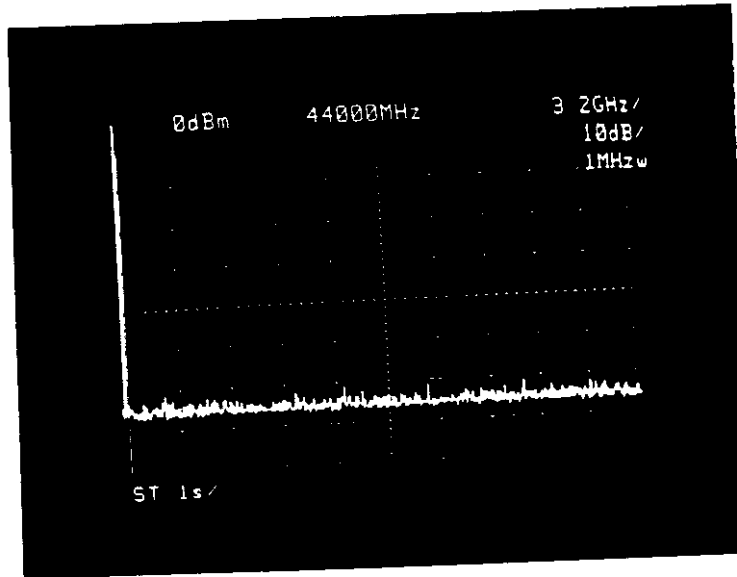

LONG PULSE

CKEJMA3811

NAME OF TEST: RECEIVER RADIATED EMISSIONS

PARAGRAPHS:

- 15. 109: RADIATION INTERFERENCE LIMITS
- 15. 231 (b): FIELD STRENGTH OF EMISSIONS FROM INTENTIONAL RADIATORS
- 15. 33: FREQUENCY RANGE OF RADIATED MEASUREMENTS
- 80. 217: SUPPRESSION OF INTERFERENCE ABOARD SHIPS

GUIDE: SEE MEASUREMENT PROCEDURE BELOW

TEST CONDITIONS: STANDARD TEMPERATURE & HUMIDITY

TEST EQUIPMENT: AS PER ATTACHED PAGE

SEARCH ANTENNAS:

- 1GHz - 18 GHz: LOGPERIODIC ANTENNA 94612-1
- 18GHz - 26.5 GHz: HORN ANTENNA 94626-1
- 26.5GHz - 40 GHz: HORN ANTENNA 94627-1

MEASUREMENT PROCEDURE

1. At first, bench tests were performed to locate the spurious emissions at the antenna terminals.
2. In the field, tests were conducted over the range shown. The test sample was set up on a wooden turntable above ground, and at a distance of three meters from the antenna connected to the Spectrum Analyzer.
3. In order to obtain the maximum response at each frequency, the turntable was rotated, and the search antennas were raised and lowered. The E. U. T. was also adjusted for maximum response. Tests conducted in Horizontal & Vertical polarization modes.
4. The field strength was calculated from:
$$E \text{ V/m @ 3 m} = \text{LOG}_{10}^{-1}(\text{dBm} + 107 + \text{A. F.} + \text{C. L.})$$

20

5. MEASUREMENT RESULTS: ATTACHED FOR WORST CASE CONDITIONS.

MEASUREMENT RESULTS: RECEIVER RADIATED EMISSIONS

SPECTRUM SEARCHED	= 0 to 10 x Fc
WORST CASE	= V
LIMITS	= 15.109(a)
RESTRICTED BAND MEASUREMENTS	= 15.205
ALL OTHER EMISSIONS	= \geq 20 dB BELOW LIMIT

TESTS WERE CONDUCTED WITH:

- a. All controls and switches operated.
- b. Half-wave dipole antenna or manufacturer/applicant supplied antenna.

SAMPLE CALCULATION:

EMISSION FREQUENCY, MHz = Less than noise level

$$\text{LEVEL} = \text{LOG}_{10}^{-1} \left(\frac{-46 + 107 + 45}{20} \right)$$

LEVEL, $\cdot\text{V}/\text{m}$ @ 3 m = 199526.2

LEVEL, $\cdot\text{V}/\text{m}$ @ 1 N.M. = 322.9

RESULTS

RADIATED RECEIVER SPURIUS EMISSIONS

All other emissions in the range specified by rule 15.33 (b) were that 20dB below the limits of 15.109(a).

TUNED, MHz	EMISSION, MHz	PEAK	RBW, kHz	VBW, kHz	A. F, C. L dB	$\mu\text{V}/\text{m}$ @3m	$\mu\text{V}/\text{m}$ @1N.M.
9420	9384	P	30.0	30.0	45	199526.2	322.9