

**Automatic Identification System**

**JHS-182**

**Instruction Manual**

**JRC** *Japan Radio Co., Ltd.*



# Preface



Thank you for purchasing JHS-182 Automatic Identification System.

JHS-182 is the Class A shipborne equipment of the universal Automatic Identification System.

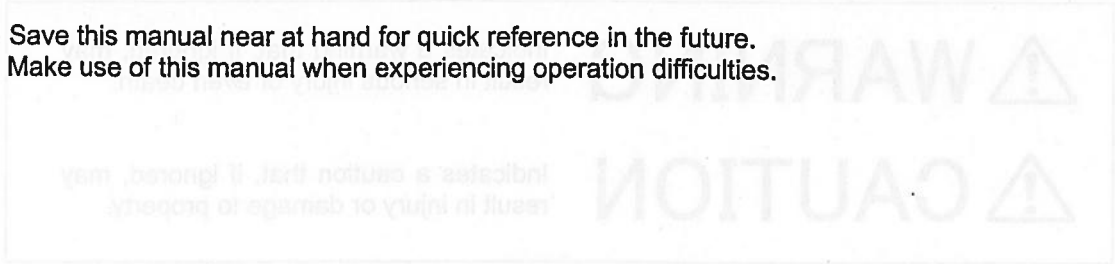
- Be sure to read this manual for full comprehension before using the equipment.
- Save this manual near at hand for quick reference in the future.  
Make use of this manual when experiencing operation difficulties.



## Examples of symbols

The  symbol indicates caution (including DANGER and WARNING). The illustration inside the  symbol specifies the content of the caution more accurately. (This example warns of possible electrical shock.)

The  symbol indicates that performing an action is prohibited. The illustration inside the  symbol specifies the content of the prohibited operation. (In this example disassembly is prohibited.)

The  symbol indicates operations that must be performed. The illustration inside the  symbol specifies obligatory instructions. (In this example unplugging is the obligatory instruction.)

## Concerning warning labels

A warning label is pasted to the top cover of this product. Do not remove, damage or modify the label.

## Before Operation

### Concerning the symbols

This manual uses the following symbols to explain correct operation and to prevent injury or damage to property.

The symbols and descriptions are as follows. Understand them before proceeding with this manual.



# WARNING

Indicates a warning that, if ignored, may result in serious injury or even death.



# CAUTION

Indicates a caution that, if ignored, may result in injury or damage to property.

### Examples of symbols



The  $\triangle$  symbol indicates caution (including DANGER and WARNING). The illustration inside the  $\triangle$  symbol specifies the content of the caution more accurately. (This example warns of possible electrical shock.)



The  $\circledR$  symbol indicates that performing an action is prohibited. The illustration inside the  $\circledR$  symbol specifies the contents of the prohibited operation. (In this example disassembly is prohibited.)



The  $\bullet$  symbol indicates operations that must be performed. The illustration inside the  $\bullet$  symbol specifies obligatory instructions. (In this example unplugging is the obligatory instruction.)

### Concerning warning labels

A warning label is pasted to the top cover of this product.

Do not remove, damage or modify the label.

## Handling Precautions

# WARNING



Do not disassemble or customize this unit. Doing so may cause fire, electrical shock or malfunction.



Do not use a voltage other than specified. Doing so may cause fire, electrical shock or malfunction.



Do not touch any parts where this warning label is pasted. Doing so may cause electrical shock.

## Handling Precautions

# CAUTION



Do not use this equipment for anything other than specified.  
Doing so may cause malfunction or damage to persons.



Do not turn the trimmer resistors or the trimmer capacitors on the PCB unit, except when and if they need to be adjusted.  
Doing so may cause malfunction or damage to persons. They are preset at the factory.



Do not install this equipment in a place other than specified or in one with excessive humidity, steam, dust or soot. Doing so may cause fire, electric shock, malfunction or damage to persons.



Do not get this equipment wet or spill any liquids on or near this equipment.  
Doing so may cause electrical shock or malfunction.



Do not place this equipment anywhere vibration or impact is likely to occur.  
Doing so may cause a fall or damage to property and persons.

## External Views

**NTE-182 AIS Transponder**

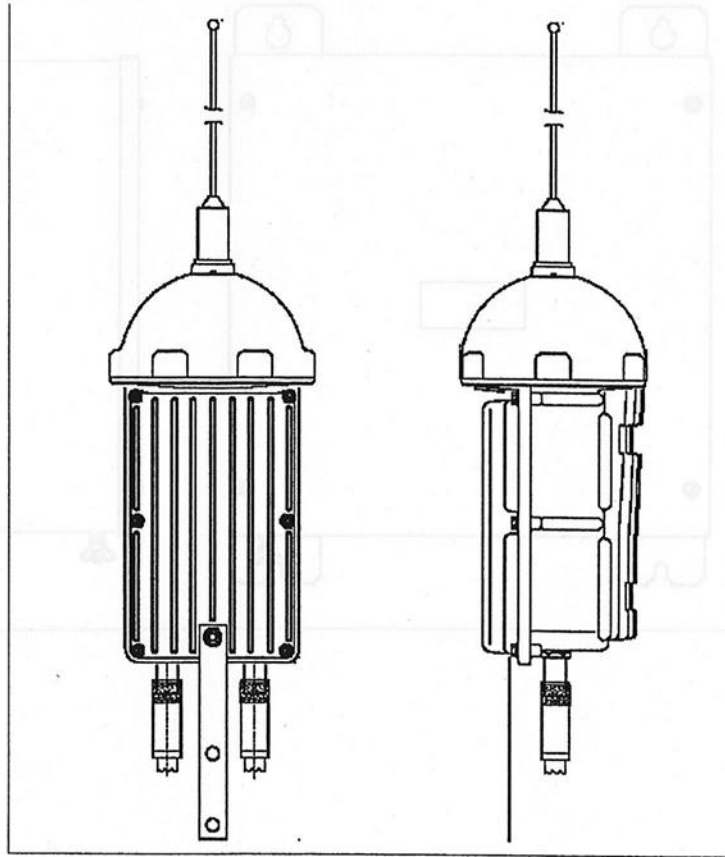

**NCM-779 AIS Controller**

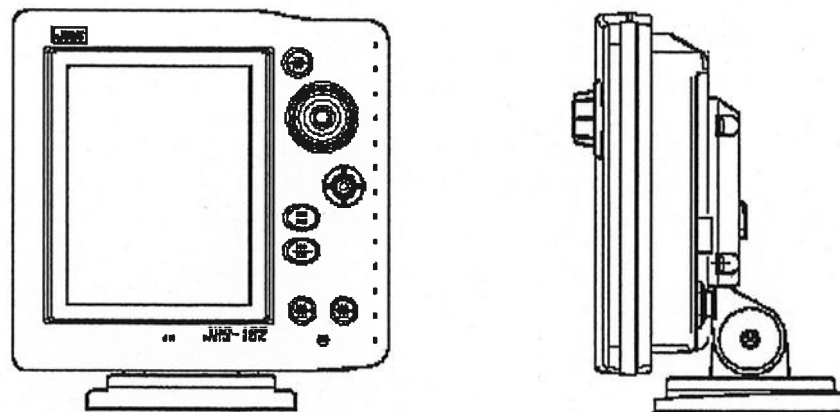

**NQE-3182 Connection Box**

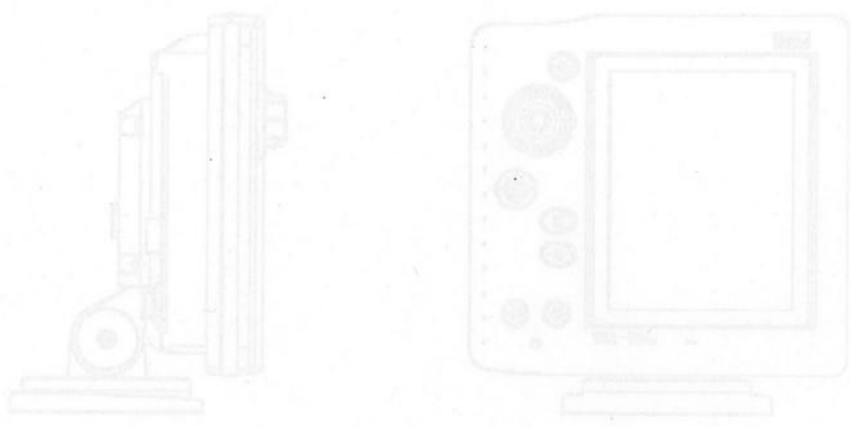
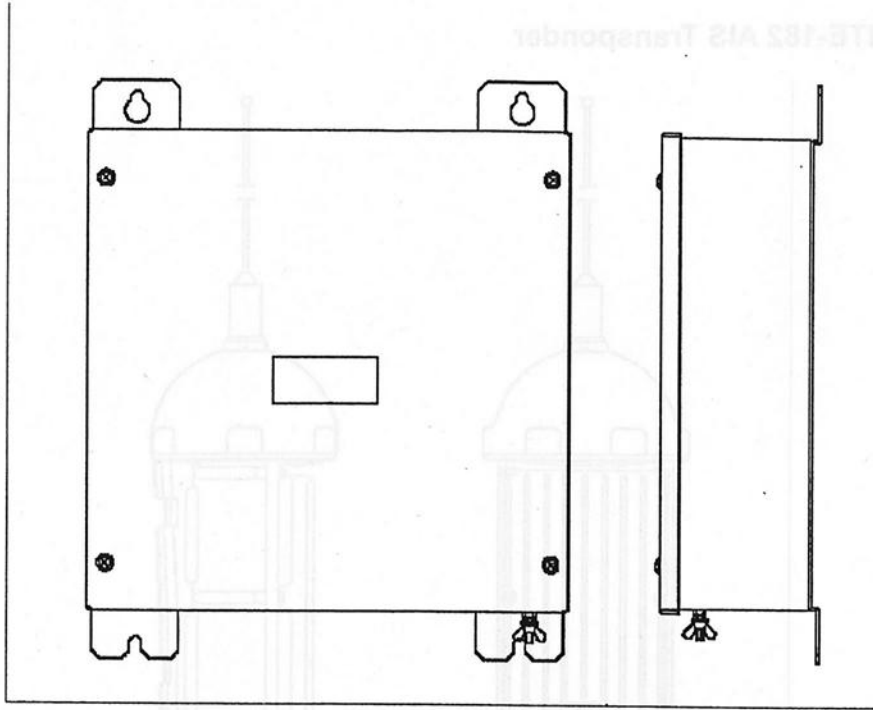



## NBD-577A Power Supply Unit

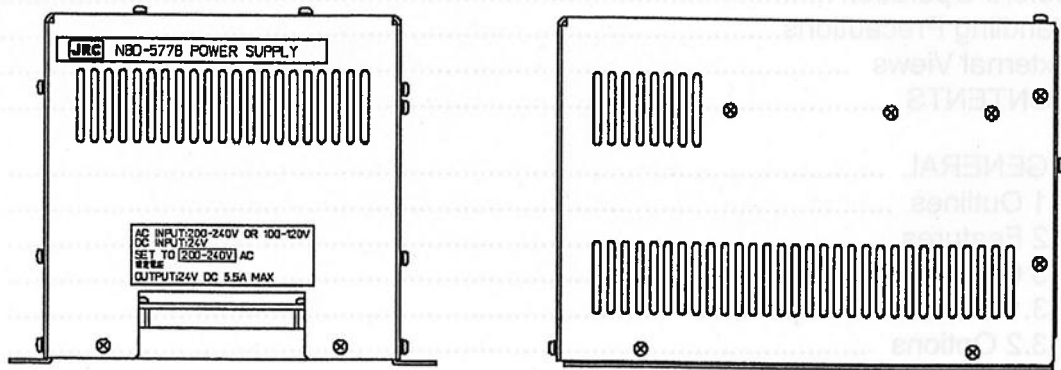

## NQD-4382 Junction Box

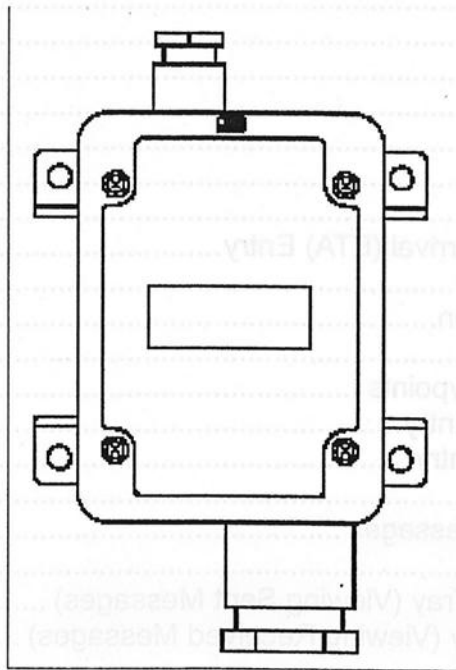

# CONTENTS

Preface .....	i
Before Operation .....	ii
Handling Precautions.....	iii
External Views .....	v
CONTENTS .....	viii
1.GENERAL .....	1-1
1.1 Outlines .....	1-1
1.2 Features .....	1-1
1.3 Components .....	1-2
1.3.1 Standard Components .....	1-2
1.3.2 Options .....	1-2
1.4 Configuration .....	1-3
2.INSTALLATION DIAGRAM .....	2-1
3.PART NAMES AND FUNCTIONS .....	3-1
4.DISPLAYS .....	4-1
5.OPERATION .....	5-1
5.1 BASIC OPERATION .....	5-1
5.1.1 Keyboard Display and Input Method .....	5-1
5.1.2 Numerical Input.....	5-1
5.2 MAIN MENU .....	5-2
5.2.1 Voyage Data Setting .....	5-3
5.2.1.1 Navigational Status .....	5-4
5.2.1.1 Navigational Status .....	5-4
5.2.1.1 Navigational Status .....	5-4
5.2.1.2 Destinations Entry.....	5-5
5.2.1.3 Estimated Time of Arrival (ETA) Entry.....	5-5
5.2.1.4 Draught Value Entry.....	5-7
5.2.1.5 Cargo Type Selection.....	5-8
5.2.1.6 Waypoints Setting .....	5-9
5.2.1.7 Giving Name to Waypoints .....	5-12
5.2.1.8 Persons on Board Entry.....	5-13
5.2.1.9 Height Over Keel Entry .....	5-13
5.2.2 MESSAGE ENTRY .....	5-14
5.2.2.1 Editing / Sending Messages .....	5-15
5.2.2.2 Retry Settings .....	5-21
5.2.2.3 Transmission (TX) Tray (Viewing Sent Messages) .....	5-22
5.2.2.4 Reception (RX) Tray (Viewing Received Messages) .....	5-24
5.2.2.5 Interrogation.....	5-26
5.2.2.6 Long Range Messages.....	5-30
5.2.3 USER ALARM SETTING .....	5-33
5.2.4 SET UP MENU .....	5-33
5.2.4.1 Contrast Adjustment .....	5-36
5.2.4.2 Time Difference Setting.....	5-37
5.2.4.3 Regional Channel Setting .....	5-38
5.2.4.4 Long Range Response Setting .....	5-41
5.2.4.5 Buzzer Setting .....	5-42

5.2.4.6 Group Ship Registration .....	5-43
5.2.4.7 Changing the Channel.....	5-44
5.2.4.8 Changing Password .....	5-45
5.2.5 MAINTENANCE .....	5-46
5.2.5.1 Self Diagnosis .....	5-47
5.2.5.2 TRX Condition .....	5-48
5.2.5.3 Alarm History .....	5-49
5.2.5.4 Sensor status .....	5-50
5.2.5.5 Power ON / OFF Log.....	5-51
5.2.5.6 Software Version .....	5-52
6.MAINTENANCE AND INSPECTION .....	6-1
6.1 General Maintenance and Inspection .....	6-1
6.2 Maintenance Menu .....	6-1
7.AFTER-SALES SERVICE .....	7-1
Before returning repair .....	7-1
Periodical maintenance recommended .....	7-1
8.SPECIFICATIONS .....	8-1
8.1 AIS TRANSPONDER (NTE-182) .....	8-1
8.2 AIS CONTROLLER (NCM-779) .....	8-1
8.2.1 Operation panel .....	8-1
8.2.2 Environmental condition .....	8-1
8.2.3 External interfaces .....	8-1
8.3 CONNECTION BOX (NQE-3182) .....	8-2
8.2.1 Environmental condition .....	8-2
8.2.2 External interfaces .....	8-2
8.2.3 Supported interface sentences .....	8-2
8.4 POWER SUPPLY UNIT (NBD-577B) .....	8-3



# 1. GENERAL

## 1.1 Outlines

Automatic Identification System (AIS) is a maritime navigation and radio communication system. This system intends to enhance the safety of life at sea, the safety and efficiency of navigation and the protection of the marine environment by communicating navigational information automatically on VHF channels between ship and ship, ship and shore.

JHS-182 meets the requirements of the SOLAS Conventions for the Class A shipborne equipment of the universal AIS. JHS-182 mainly consists of AIS Transponder and AIS Controller. The combined antenna and transponder design allows installation at any convenient location on any vessels. The small and simple design controller allows easy installation and operation. JHS-182 employs the latest technologies such as digital signal processing, circuit integration technology, and these technologies ensure high performance and high reliability.

## 1.2 Features

### ● Fully Comply with International Regulations

JHS-182 is designed to meet the requirements of the SOLAS Conventions for the Class A shipborne equipment of the universal AIS and fully complies with international regulations: IMO MSC74(69) Annex 3, ITU-R M.1371, IEC61993-2, IEC60945 etc.

### ● Combined Antenna and Transponder for Ease of Installation

JHS-182 employs the combined antenna and transponder design. This design allows installation at any convenient location on any vessels. For the connection between above deck component and below deck component, only one cable is needed.

### ● Increased Probability of Vessel Detection

JHS-182 is equipped with a guard zone alert function. When preset guard zone range and other vessel enters into the zone, JHS-182 indicates and sounds the alert. This function enhances probability of vessel detection.

### ● Recognition of Own-group Vessels

JHS-182 is equipped with a recognition of own-group vessels function. When preset own-group vessels' identification in advance, the display indicates the own-group vessel sign. This sign allows easy recognition of own-group vessels.

### ● Self-diagnosis Function

JHS-182 is equipped with a built-in automatic self-diagnosis function. This function allows easy maintenance and high system reliability.

### ● System Integration Availability

JHS-182 is equipped with various interfaces. These interfaces allow system integration and future expansions.

## 1.3 Components

### 1.3.1 Standard Components

No.	Name	Type	Quantity	Remarks
1	AIS Transponder	NTE-182	1	
2	AIS Controller	NCM-779	1	
3	Control Cable	7ZCJD0214	1	L=10m
4	Connection Box	NQE-3182	1	
5	Spare Parts	7ZXJD0049	1	Fuses
6	Instruction Manual	7ZPJD0226	1	

### 1.3.2 Options

No.	Options	Type	Quantity	Remarks
1	Power Supply Unit	NBD-577B	1	
2	Junction Box	NQE-4182	1	
3	Flash Mount Kit	MPBP	1	

# 1.4 Configuration

## • System Block Diagram

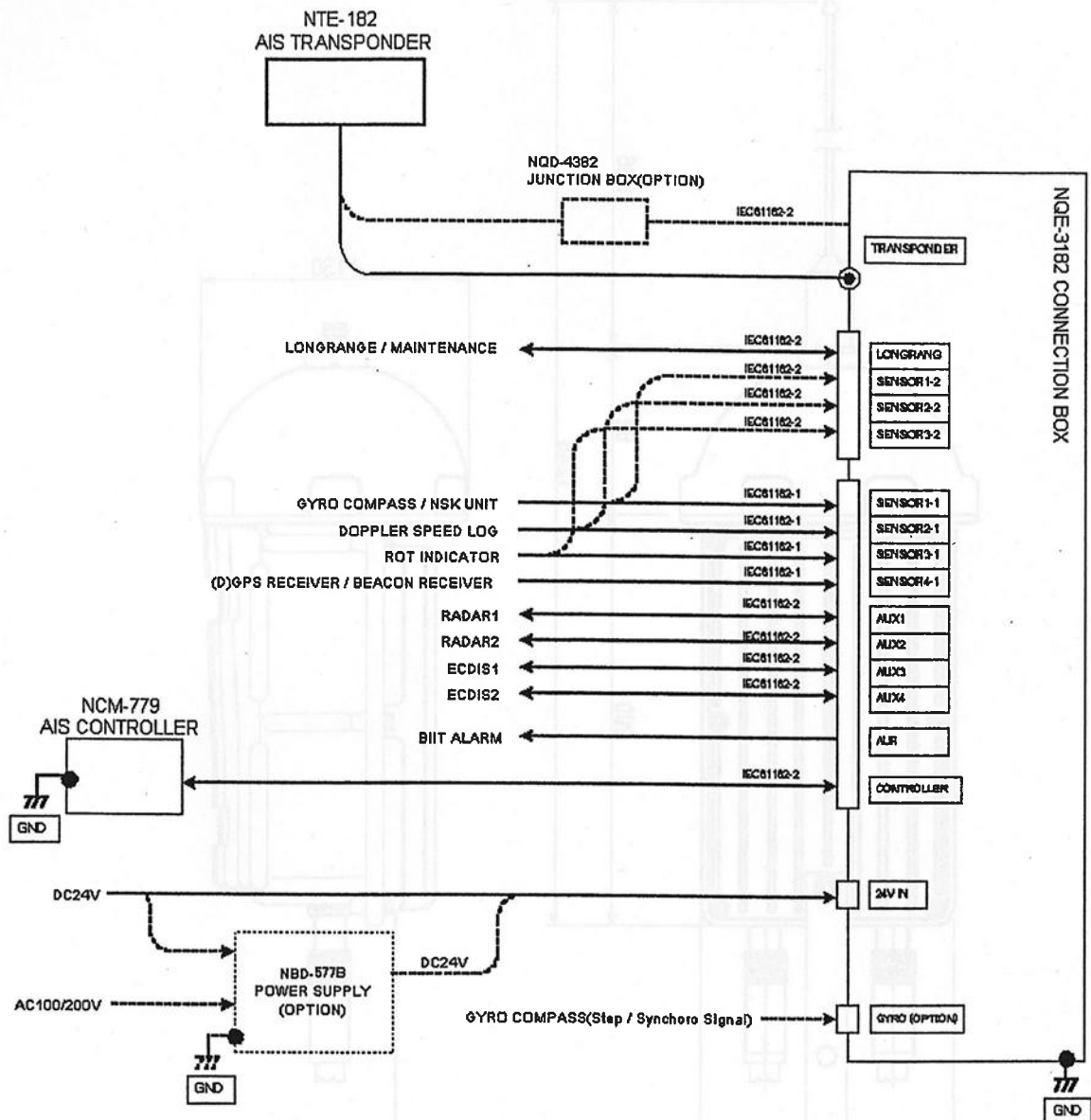

• Outline Drawing of NTE-182 AIS Transponder

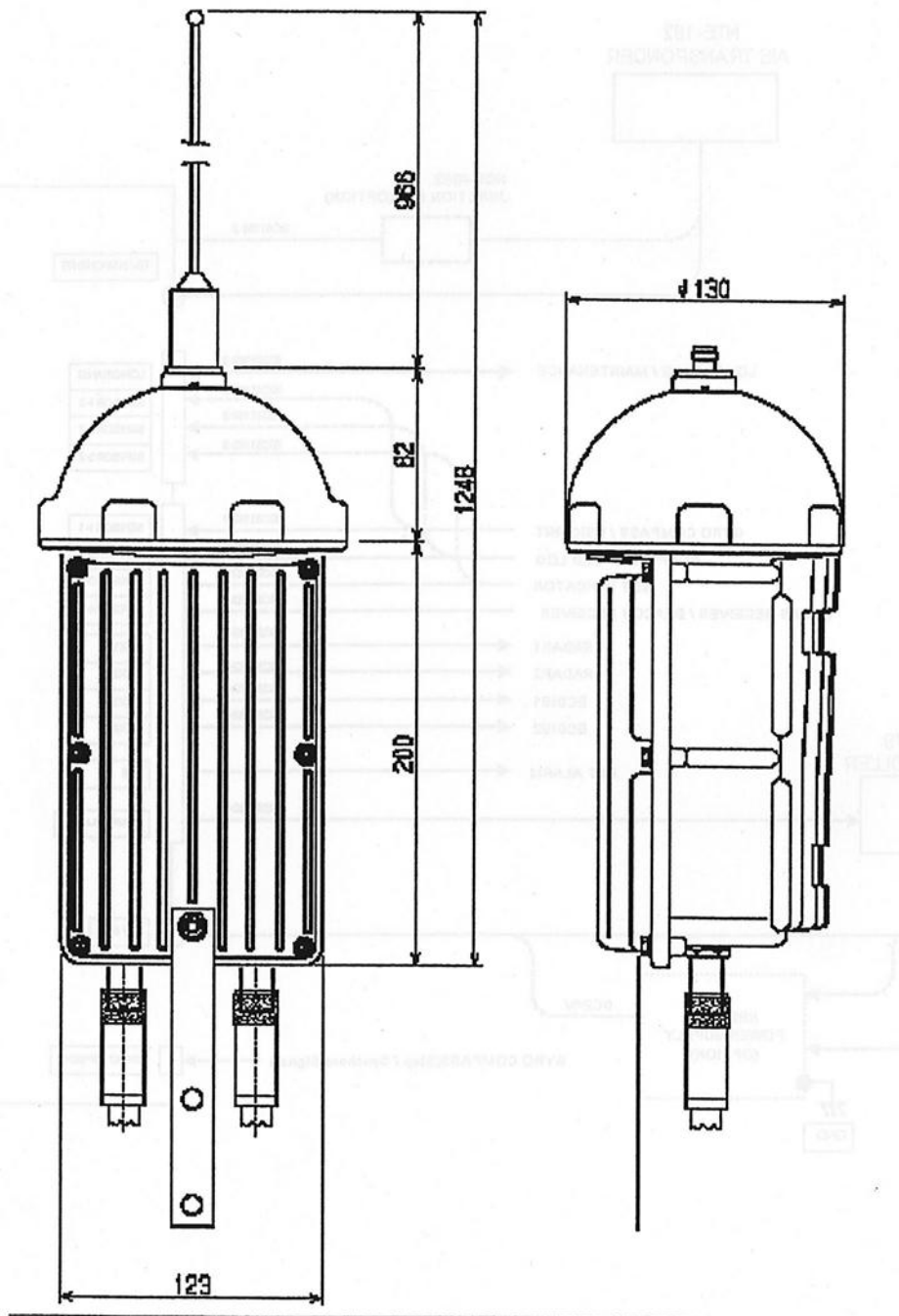

Unit: mm  
Mass: approx. 2.5 kg



• Outline Drawing of NCM-779 AIS Controller

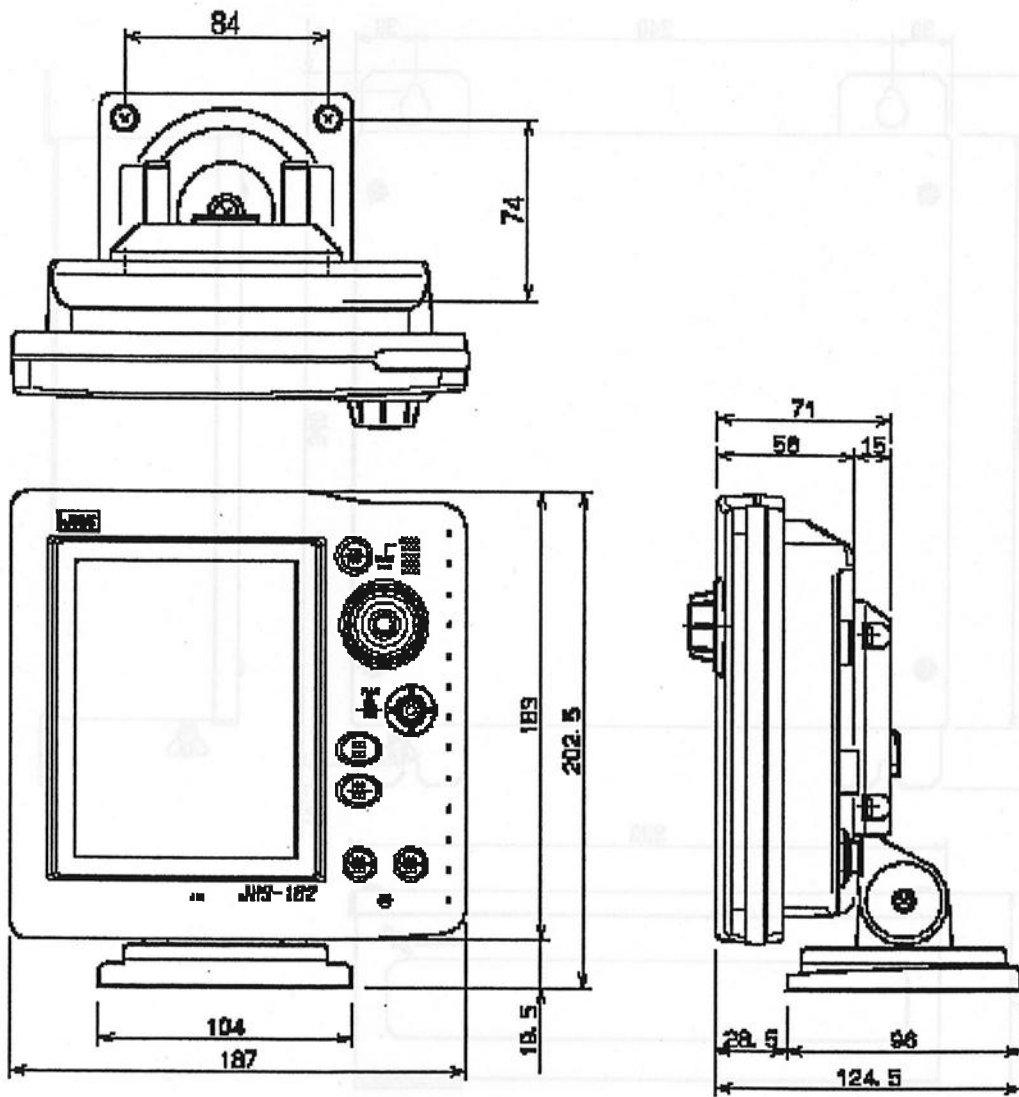

Unit: mm  
Mass: approx. 1.1 kg

• Outline Drawing of NQE-3182 Connection Box

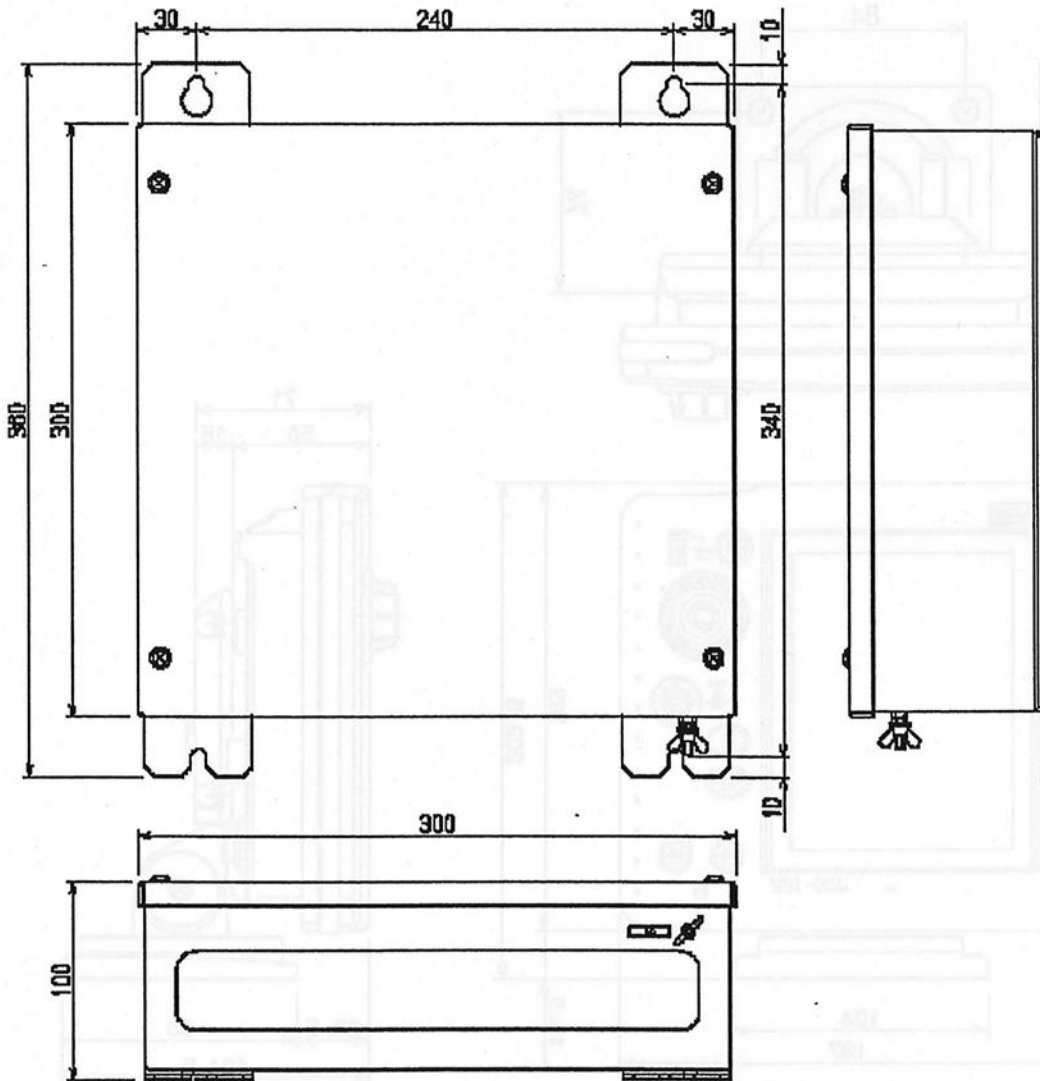

Unit: mm  
Mass: approx. 2.4 kg

• Outline Drawing of NBD-577B Power Supply Unit

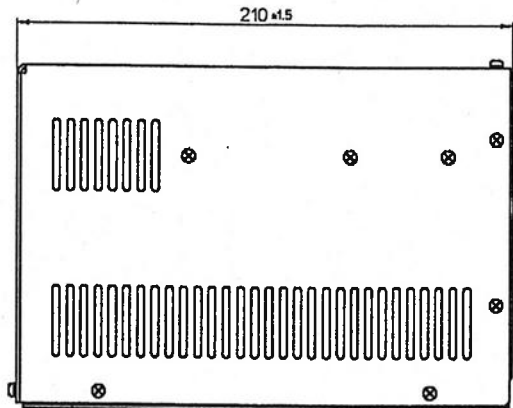
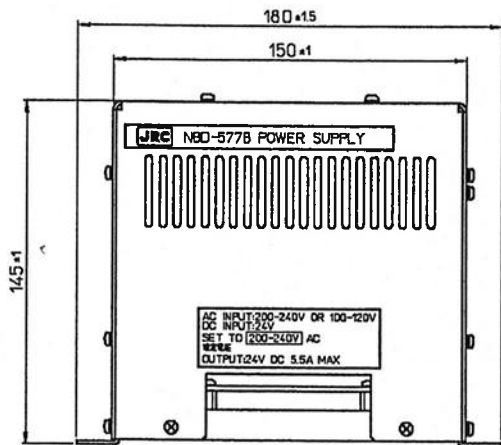
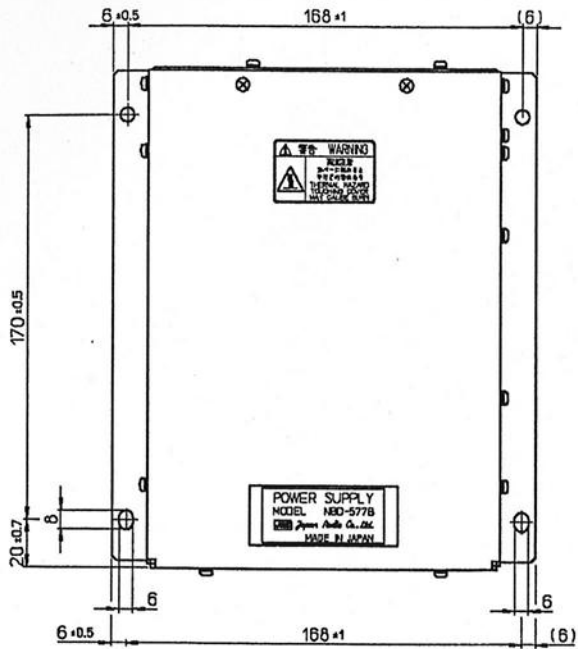

Unit: mm  
Mass: approx. 3.8 kg



# 2. INSTALLATION DIAGRAM

Notes:

Leave installation of this equipment to our service center or agents. Installation by an unauthorized person may results in malfunction.

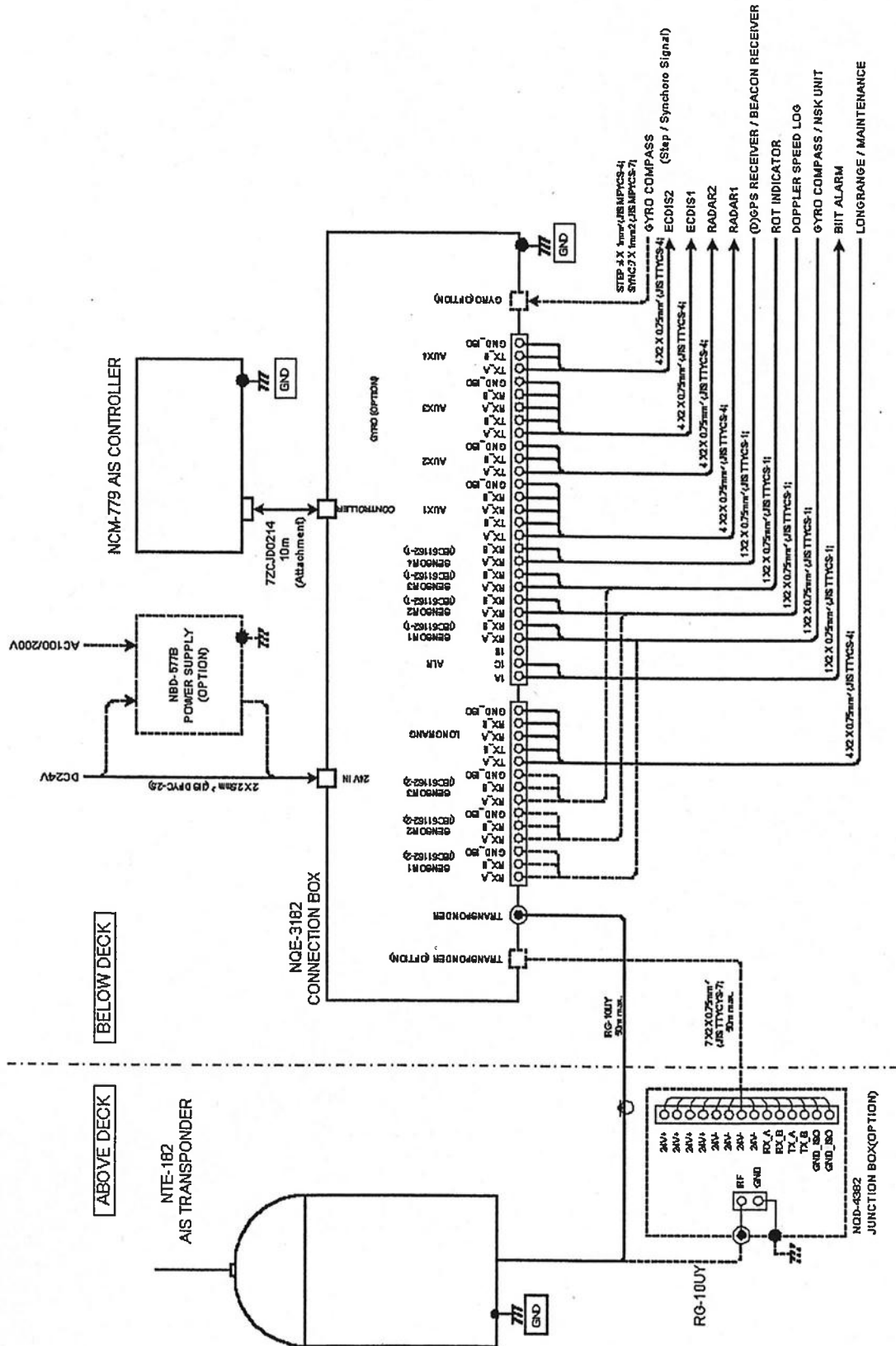



### 3. PART NAMES AND FUNCTIONS

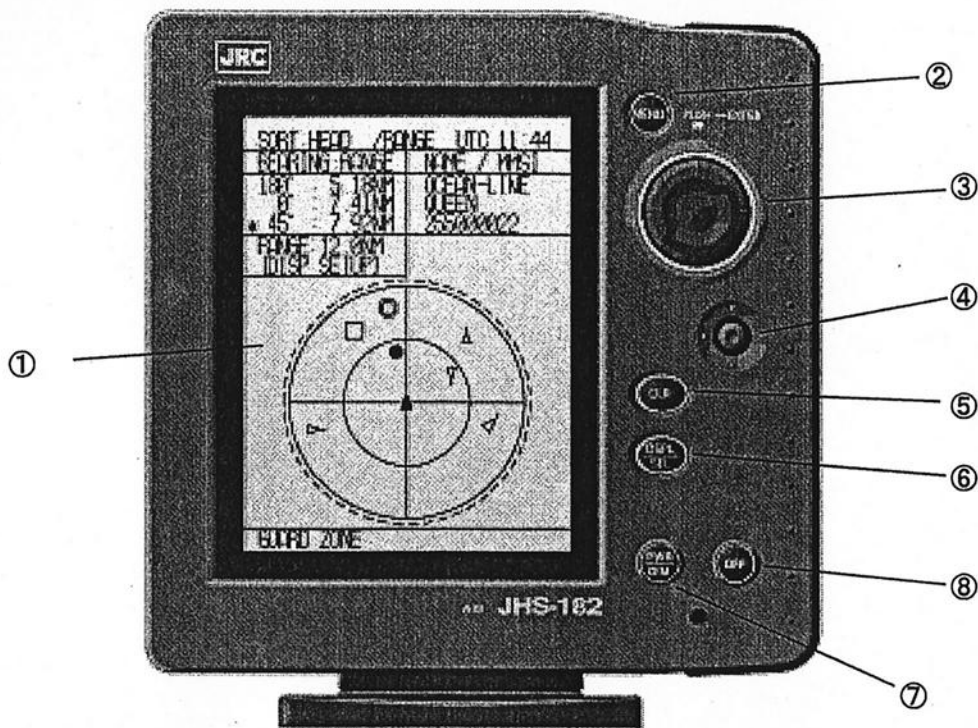

① **LCD Panel**

For further information, refer to "4. Display".

② **Menu key**

Displays the Main-menu.

③ **Jog Dial**

Move the cursor upward, downward, to the left or to the right.

④ **Stick**

Move the cursor (Keyboard display, etc.).

⑤ **CLR key**

Clears input errors.

Off the alarm sound when beeping alarm sound.

⑥ **DSPL – Select key**

Change the screen.

⑦ **Power/Dimmer key**

Turn the power ON.

Adjusts the back light brightness of the LCD and key in four stages.

(Each time [PWR/DIM] is pressed, the display dims one stage at a time.)

⑧ **Power OFF key**

Pressing [PWR/DIM] and [OFF] at the same time turn the power OFF.









# 5. OPERATION

## 5.1 BASIC OPERATION

### 5.1.1 KEYBOARD DISPLAY AND INPUT METHOD

MAIN MENU		UTC 11:43
BEARING : RANGE	NAME / MMSI	
270° : 0.18NM	HAGAMARU	
35° : 0.29NM	JRCMARU	
* 22° : 0.92NM	ABCDEFG—MARU	
ABCDEFGHIJKLMNOP QRSTUVWXYZ. 0123 456789↓[\]_“#\$\$%&’ ()?@+*/^, :;<=>!		Text Setting Screen

When input operation begins, the cursor comes on “A” in the keyboard Area at left-low of the screen.

Bring the cursor “I” in the keyboard area, and rotate the Jog Dial to right then the cursor jumps to the top-row of the Text Setting Screen.

When the cursor is on the top-row of the Text Setting Window, if the Jog-Dial is rotated left, the cursor jumps to “I” in the Keyboard Area.

### 5.1.2 NUMERICAL INPUT

The method for entering numbers is mentioned below.

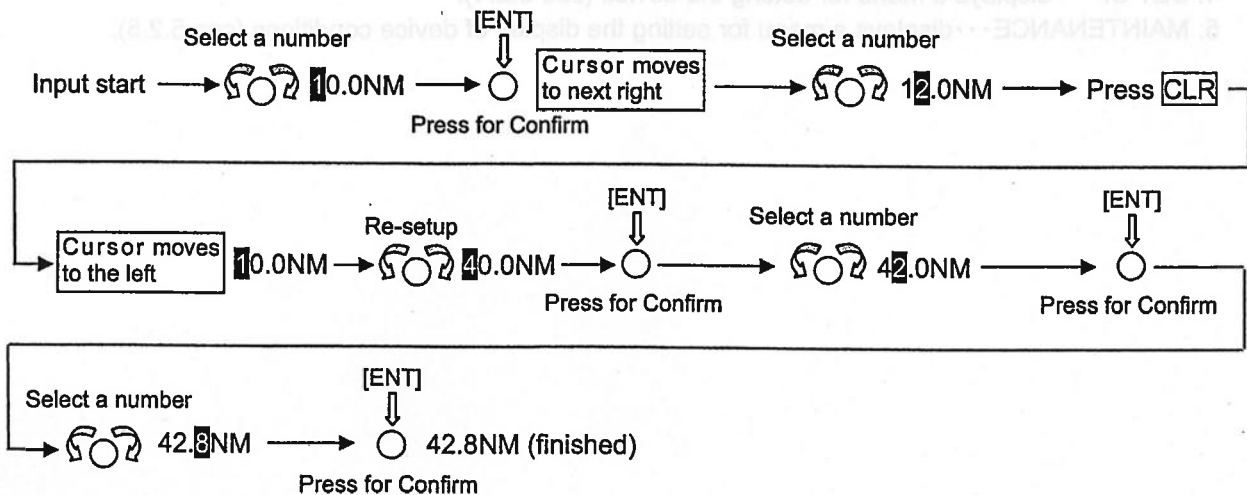

The numbers are always entered from left to right.  
 When **CLR** key is pushed, an input position (Cursor) moves to the left.

## 5.2 MAIN MENU

Main Menu displays menu items for making changes/confirmations of setting, and creating/confirming messages.

Main Menu is reachable from any screens by pressing **MENU** key.

MAIN MENU		UTC 11:44
BEARING : RANGE	NAME / MMSI	
270° : 0.18NM	HAGAMARU	
35° : 0.29NM	JRCMARU	
* 22° : 0.92NM	ABCDEF—MARU	
<b>1. VOYAGE STATIC DATA SETTING</b>		
2. MESSAGE		
3. ALARM SETTING		
4. SET UP		
5. MAINTENANCE		

Main Menu

Rotate right/left the Jog Dial for moving the cursor over the menu.  
When the Jog Dial is pressed, the selected menu is displayed.

The outlines of Menus are:

1. VOYAGE STATIC DATA SETTING...displays a menu for setting voyage information (see 5.2.1)
2. MESSAGE...displays a menu for sending/receiving messages (see 5.2.2).
3. ALARM SETTING...displays a menu for setting alarms (see 5.2.3).
4. SET UP...displays a menu for setting the device (see 5.2.4).
5. MAINTENANCE...displays a menu for setting the display of device conditions (see 5.2.5).

## 5.2.1 VOYAGE DATA SETTING

When **1. VOYAGE STATIC DATA SETTING** is selected, a menu for setting voyage data appears

VOYAGE DATA SETTING UTC 11:44	
BEARING : RANGE	NAME / MMSI
270° : 0.18NM	HAGAMARU
35° : 0.29NM	JRCMARU
* 22° : 0.92NM	ABCDEFG—MARU
<b>1. NAVIGATIONAL STATUS :</b>	
RESTRICTED MANOEUVRABILITY	
<b>2. DESTINATION :</b>	
YOKOHAMA_CYU-KAGAI	
<b>3. ETA</b>	: 2004/12/31 23:31
<b>4. DRAUGHT</b>	: 25.5M OR MORE
<b>5. CARGO/STATUS:</b>	
CATEGORY A (DG/HP/MP)	
<b>6. WAYPOINTS</b>	
<b>7. WAYPOINT TEXT:</b>	
ABCDEFGHIJKLMNQRST	
<b>8. PERSONS ON BOARD</b>	:8191 OR MORE
<b>9. HEIGHT OVER KEEL</b>	:204.7M
[EXIT]	[ENT]

Voyage Data Setting Menu

When the Jog Dial is rotated left or right, the cursor moves upwards or downwards accordingly.

Then select an item from the menu.

Press the Jog Dial when the cursor is on your selection, then it is confirmed and a submenu appears.

When **[CLR]** key is pressed, you go back to the main menu.

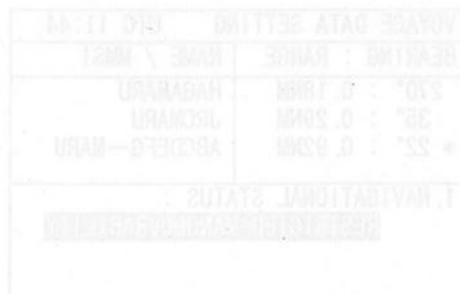

The outlines of menu items are:

1. NAVIGATIONAL STATUS...select navigational status. (see 5.2.1.1)
2. DESTINATION...input information of the destination. (see 5.2.1.2)
3. ETA...input ETA(expected time for arrival). (see 5.2.1.3)
4. DRAUGHT...input draught value.(see 5.2.1.4)
5. CARGO/STATUS...select cargo/status.(see 5.2.1.5)
6. WAYPOINTS...set waypoints (max 14 points)(see 5.2.1.6)
7. WAYPOINTS TEXT...input waypoints name.(see 5.2.1.7)
8. PERSONS ON-BOARD...input a number of persons on-board.(see 5.2.1.8)
9. HEIGHT OVER KEEL...input value of the height over keel(see 5.2.1.9)

## 5.2.1.1 NAVIGATIONAL STATUS

When **1.NAVIGATIONAL STATUS** is selected, navigation status is ready to be selected.

When the Jog Dial is pressed on **1.NAVIGATIONAL STATUS**, the cursor moves down to the next line. On the line, as the Jog Dial is rotated the displayed item changes, therefore rotate the Jog Dial until the item that you want to select is displayed.

Once the item is displayed, confirm the cursor is on it and press the Jog Dial. Then the selection was made and you will go to the next step (2. DESTINATION).

When **CLR** key is pressed, the input procedure is terminated and you go back to the Voyage Data Setting Menu.

VOYAGE DATA SETTING		UTC 11:44
BEARING : RANGE	NAME / MMSI	
270° : 0.18NM	HAGAMARU	
35° : 0.29NM	JRCMARU	
* 22° : 0.92NM	ABCDEFG—MARU	
1. NAVIGATIONAL STATUS :		
<b>RESTRICTED MANOEUVRABILITY</b>		

Navigational Status

The Navigational Status will be selected from the list below:

- UNDER WAY USING ENGINE
- AT ANCHOR
- NOT UNDER COMMAND
- RESTRICTED MANOEUVRABILITY
- CONSTRAINED BY HER DRAUGHT
- MOORED
- AGROUND
- ENGAGED IN FISHING
- UNDER WAY SAILING
- RESERVED FOR HSC
- RESERVED FOR WIG
- NOT DEFINED

### 5.2.1.2 DESTINATIONS ENTRY

When **2.DESTINATION** is selected, the name of the destination is ready to be entered. The name can be entered with the keyboard at left-bottom part of the screen.  
See "5.1.1 KEYBOARD DISPLAY AND INPUT METHOD" for the entrance operation by the keyboard.

The function of the keyboard setting window is as below:

VOYAGE DATA SETTING		UTC 11:44
BEARING : RANGE	NAME / MMSI	
270° : 0.18NM	HAGAMARU	
35° : 0.29NM	JRCMARU	
* 22° : 0.92NM	ABCDEFG—MARU	
1. NAVIGATIONAL STATUS : RESTRICTED MANOEUVRABILITY		
2. DESTINATION : YOKOHAMA_CYU-KAGA		
7. WAYPOINT TEXT: ABCDEFGHIJKLMNQRST		
ABCDEFGHIJKL	MNOP	[EXIT]
QRSTUVWXYZ.	0123	[ENT]
456789	[ ]_ "#\$%&'	
()?@+*/^.,:;<=>!		[CLEAR]

- Up to 20 characters can be entered for naming destination.
- If [EXIT] at the right-bottom part of the screen is selected and confirmed, the contents you have already entered will be canceled and the cursor will return to **2.DESTINATION**. Additionally, the keyboard display will also be closed.
- When [ENT] is selected, the contents you have already entered is applied (not canceled). And the keyboard display is closed and the cursor moves to the next item (3. ETA)
- If [CLEAR] is selected, the contents already input are canceled and the cursor will return to the top of the input area.

### 5.2.1.3 ESTIMATED TIME OF ARRIVAL(ETA) ENTRY

When **3.ETA** is selected, ETA(Expected Time of Arrival) is ready to be entered.  
Enter ETA in the order of Year-Month-Day.

See 5.1.2. Numerical Input for the methodology of the numerical input.  
'/' will be inserted automatically between "Year and Month", and "Month and Day."

| 3. ETA : 2004/12/31 23:30 |

ETA(Expected Time of Arrival)

## a) ETA SETTING METHOD

Enter Expected Time of Arrival (date and UTC) with jog dial.  
 Enter ETA in the order of "Year-Month-Day-Hour-Minute."  
 After MINUTE is entered, the cursor moves to the next line (4.DRAUGHT).

## b) ETA VALUE AND WARNINGS

Although a date which is prior to the actual date cannot be set in principle, it is acceptable on the condition of performing this setting when UTC data is not obtainable.  
 But if UTC is obtained after such setting and current value is older than UTC, a warning display below will appear and a buzzer will be rung.  
 The warning screen and buzzer can be canceled by **CLR** button. Then the input value returns to a default value.

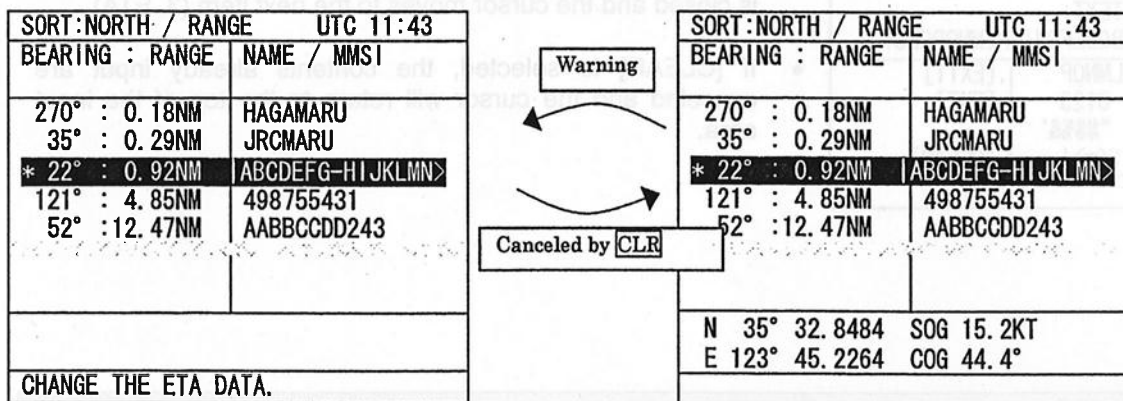

Warnings on SORT:NORT/RANGE



#### 5.2.1.4 DRAUGHT VALUE ENTRY

When **4. DRAUGHT** is selected from Voyage Data Setting Menu (5.2.1), you are ready to enter the draught value. Enter the value according to the procedure of 『5.1.2 Numerical Input.』 Up to 25.5 can be entered as the draught value.

| 4. DRAUGHT : 25.4M |  
Draught Value Entry

After a confirmation by pressing the Jog Dial, the cursor moves down to the next item (5.CARGO/STATUS).

When **CLR** key is pressed, the numerical input procedure is terminated and the cursor returns to **4. DRAUGHT**.