

Issued : 2014.03.21

Messrs. Ricoh Company limited

NISSEI ELECTRIC CO.,LTD.

1509 Okubo-Cho, Nishi-Ku
Hamamatsu-City,
Shizuoka-Pref.,
〒432-8006 JAPAN

SPECIFICATION

Antenna Assembly with FEP Insulated High Frequency Coaxial Cable

Customer Part No. : E0A43040
Design. NO. : ANT1722-161CG/M-AB

Acknowledgement (Receipt)

Please return us this form with Signed and Sealed.

2014.03.21
Nissei Electric Co., Ltd.

For Customer

Company :

Signature :

Printed name :

Title :

REVIEWED BY:

NISSEI ELECTRIC CO.,LTD.

Prepared J. Ito
ENGINEERING DEPT. T.ITO

NISSEI ELECTRIC CO.,LTD.

Approval N.akei
ENGINEERING DEPT. N.KAKEI
MANAGER

Issued: Mar. 13.2014
Revised:

GAIN特性

Gray cable

2450 MHz	
Ave. Gain [dBi]	-6.38

5150 MHz	
Total Ave. Gain [dBi]	-4.63

5350 MHz	
Ave. Gain [dBi]	-4.67

5725 MHz	
Ave. Gain [dBi]	-4.54

2450 MHz			
X-Y			
H Ave.	H Peak	V Ave.	V Peak
-4.77	-0.69	-10.85	-5.44
X-Y Ave. Gain [dBi]		-6.82	

5150 MHz			
X-Y			
H Ave.	H Peak	V Ave.	V Peak
-3.74	3.32	-9.15	-3.38
X-Y Ave. Gain [dBi]		-5.65	

5350 MHz			
X-Y			
H Ave.	H Peak	V Ave.	V Peak
-4.24	2.49	-9.26	-2.40
X-Y Ave. Gain [dBi]		-6.06	

5725 MHz			
X-Y			
H Ave.	H Peak	V Ave.	V Peak
-4.44	1.85	-9.60	-5.07
X-Y Ave. Gain [dBi]		-6.30	

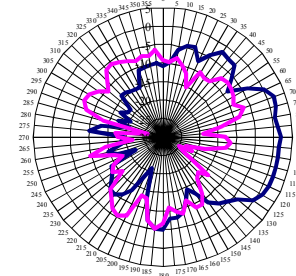
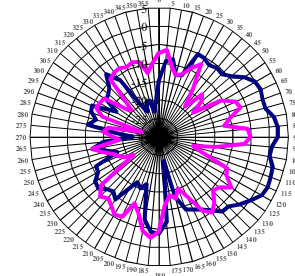
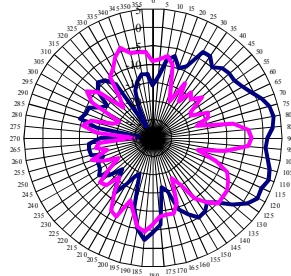
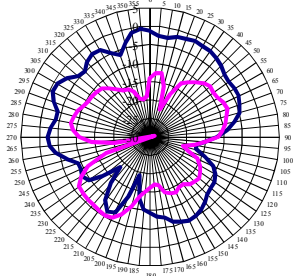

2450 MHz			
Z-X			
H Ave.	H Peak	V Ave.	V Peak
-12.17	-7.19	-3.56	0.54
Z-X Ave. Gain [dBi]		-6.01	

5150 MHz			
Z-X			
H Ave.	H Peak	V Ave.	V Peak
-4.36	0.46	-7.26	-0.44
Z-X Ave. Gain [dBi]		-5.58	

5350 MHz			
Z-X			
H Ave.	H Peak	V Ave.	V Peak
-3.72	1.25	-7.64	-0.51
Z-X Ave. Gain [dBi]		-5.25	

5725 MHz			
Z-X			
H Ave.	H Peak	V Ave.	V Peak
-2.82	2.88	-7.16	-0.77
Z-X Ave. Gain [dBi]		-4.47	

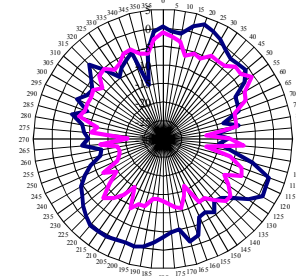
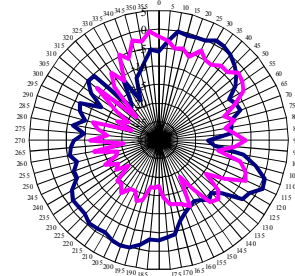
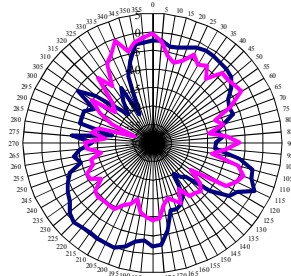
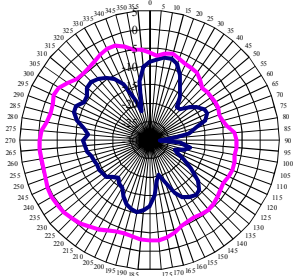

2450 MHz			
Y-Z			
H Ave.	H Peak	V Ave.	V Peak
-5.05	0.73	-8.21	-2.12
Y-Z Ave. Gain [dBi]		-6.35	

5150 MHz			
Y-Z			
H Ave.	H Peak	V Ave.	V Peak
-6.75	-1.25	-1.21	4.47
Y-Z Ave. Gain [dBi]		-3.15	

5350 MHz			
Y-Z			
H Ave.	H Peak	V Ave.	V Peak
-6.96	-0.68	-1.22	3.95
Y-Z Ave. Gain [dBi]		-3.21	

5725 MHz			
Y-Z			
H Ave.	H Peak	V Ave.	V Peak
-7.48	-2.28	-1.28	4.31
Y-Z Ave. Gain [dBi]		-3.35	

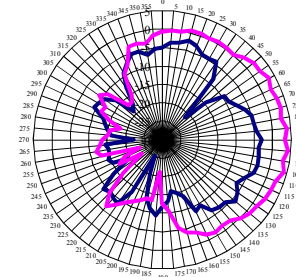
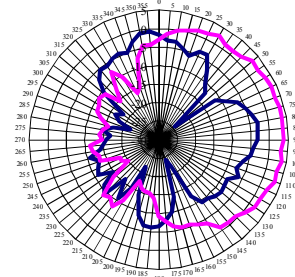
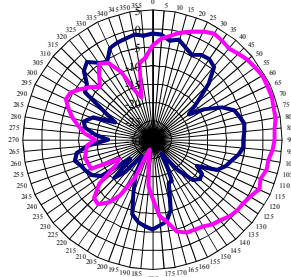
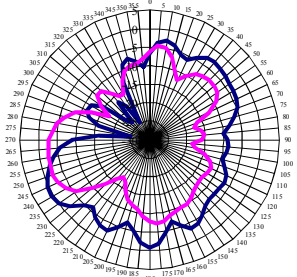

— cableH[dBi]
— V[dBi]

Application

This specification applies to Antenna Assembly with FEP Insulated High Frequency Coaxial Cable

1. Construction

Refer to appending drawing.

2. Measure and characteristic

The measure of antenna assembly is referenced to attached a drawing

3 - 1. The measure of Coaxial cable and characteristic

Refer to appending NSP-9-13472.

3-2. Character of antenna

Head	Standard value※1	Remarks
V. S. W. R. -INSPECTION JIG	Less than 3.8 at 2.3~2.7GHz Less than 2.9 at 3.4~3.8GHz Less than 2.5 at 5.15~5.875GHz	Network Analyzer
Band Wide Center Freq. (Reference value)	Nominal 2.45GHz Nominal 5.25GHz	Network Analyzer
Band Wide (Reference value)	2.4GHz band: More than 300MHz 5.2GHz band: More than 1000MHz	Network Analyzer
Peek Gain (Reference value)	2.4GHz Less than 4.0dBi 5.2GHz Less than 5.0dBi	The cable loss is contained.

※1 The shake of a characteristic curve and the abnormalities in a point should not be within measurement frequency.

3-3. Processed-goods characteristic

Head	Unit	Standard value	Remarks
Appearance		There needs to be no practically detrimental fault.	Viewing
Temperature range of operation	℃	-10~60	
Humidity range of operation	%	20~80	
Preservation temperature range	℃	-20~70	
Preservation humidity range	%	5~95	
Processing part tensile strength	N	More than 5	Only a first time examination is carried out.

3-4. Others

1. Storage in a cool place, and avoid the place of heat and high humidity.
2. Make a guarantee term into one year after a shipment day after the above-mentioned storage.
3. Forbid the following actions in the handling of the packed-up product.
 - a. Fall from a height of 30cm or more
 - b. The shock and stress which exerts modification on the packing coating
 - c. It is a strong continuation vibration rather than it receives by the usual automobile transportation.
4. Satisfy the following specifications.
 - . Common Specification on Prohibiting Use of Hazardous Substances. : A1CA00051-0560
 - . Common Specification on Material-Caused Failure. : N1CA00001-0451

4. Identification

To each one box, a tag printed following items shall be attached.

1) Part name 2) Quantity 3) Manufacturer

※Lot number is indicated on Inspection report.

5. Packing

It packs up so that a product may not be damaged during conveyance and storage.

(Remarks)

- 1 The revision of the specifications shall be mutually agreed between two parties.
- 2 The disclosure of the specifications to the third party shall be prohibited unless mutually agreed.
- 3-1 The product is subject to the "Catch-all" control and the Supplemental "Catch-all" control on countries under the UN Security Council Arms embargo (Clause 16th(1)(2) of Appended Table 1 of the Export Trade Control Order of Japan). Therefore if you intend to export the product to the non-white countries or the countries under the UNCA embargo (Appended Table 3-2 of the ETCO of Japan) from Japan, you shall determine by yourself based on rated laws of Japan and comply with them.
- 3-2 (For International customers) The product is subject to the "Catch-all" control under the ETCO of Japan. Any military use of the products shall be subject to our confirmation.
- 4 In case of processing the products for your own applications or purposes, the fitness for use of the products shall not be guaranteed.



The specified dimension and properties of the products as defined in the specifications may vary depending on usage environments and/or methods.

Attached sheet : The display method A display shall append the following labels to a carton box.
(Vertical x width : about 125mmx 245mm)

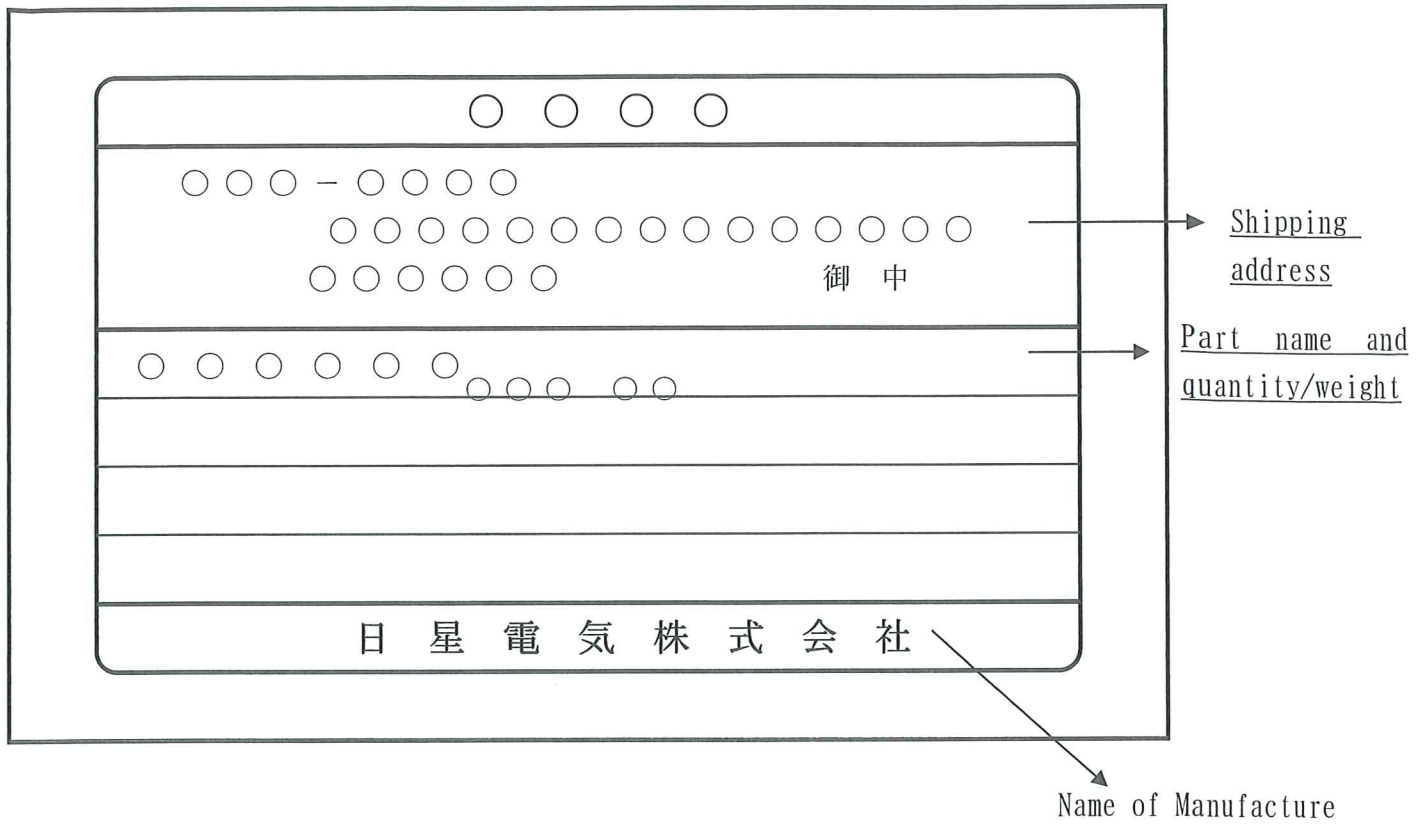

Notes

- The sheet metal is transformed by an excessive impact. Note the handling when it transports it.
- Do not touch by hand the antenna element.

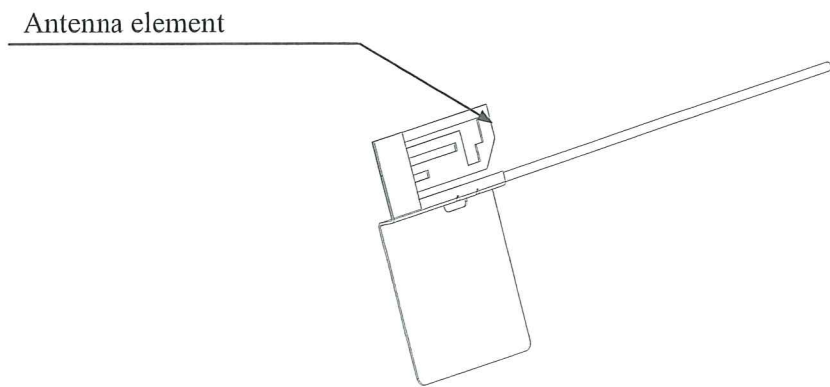

Packing Procedure

- ① Put antenna into the vinyl bag. (refer to photograph 1)

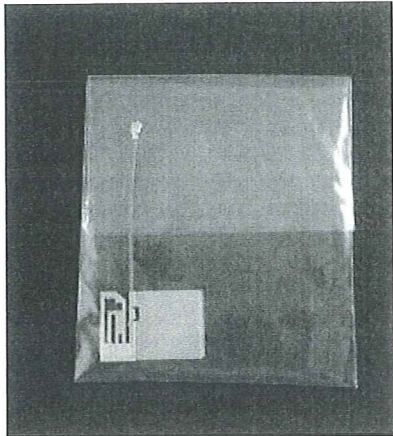

(photograph 1)

- ② Put 5 products into air mat. (refer to photograph 2)

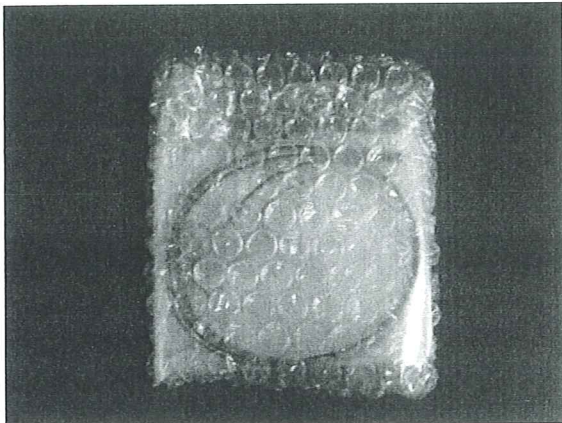

(photograph 2)

- ③ Put air mat like a photograph 2 in one section of inner carton box. (refer to photograph 3)
Repeat item until 100 products are loaded in the inner carton box.

※ Pave one air mat in the bottom of Figure 1 cardboard beforehand

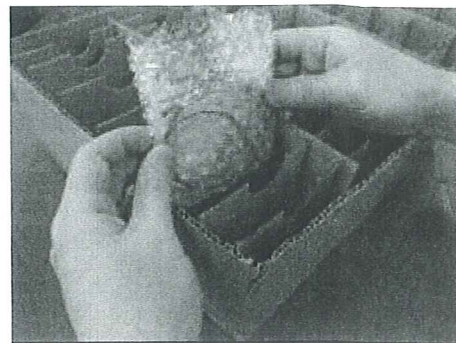
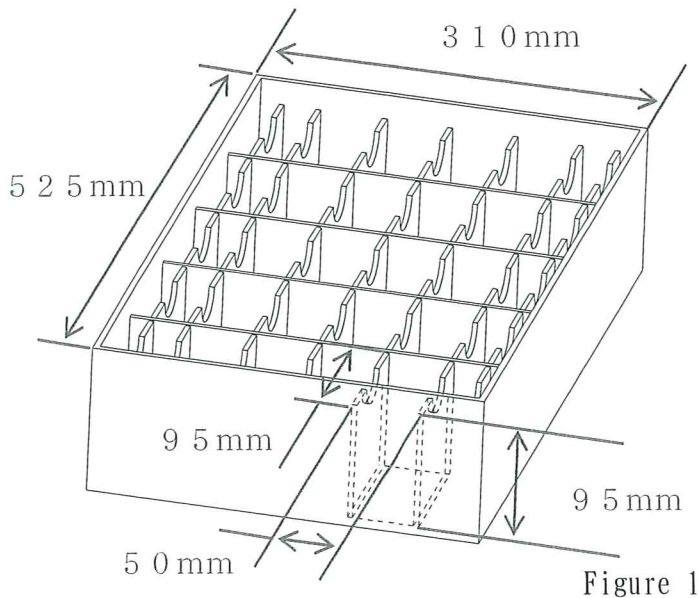

(photograph 3)

- ④ Five pieces per 20 division are put, and 100 pieces or less are put.
Repeat until 3 inner carton boxes are loaded in the outer carton box.
- ⑤ Put a carton paper into top of outer carton box.

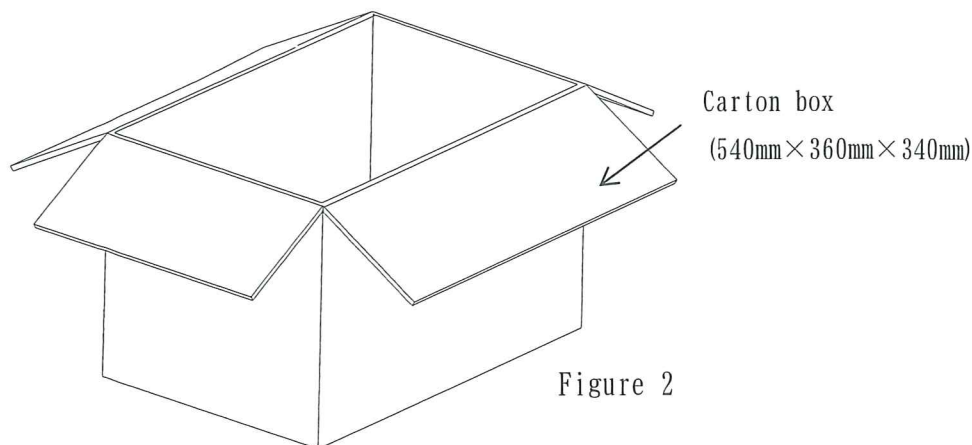

- ⑥ The air mat and the cardboard are paved on steps on most, it covers with the cardboard, and it shuts.
NOTE: When carton is not fully filled, put empty carton (figure 1) under filled carton.

- The display of a care mark

The following figures should be printed by two sides.

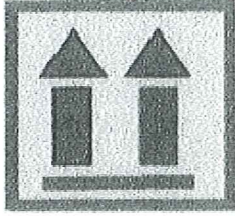

THIS WAY UP

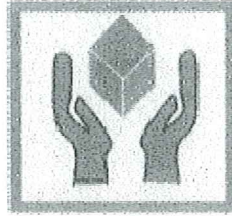

HANDLE WITH CARE

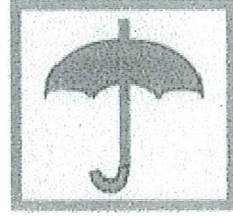

KEEP DRY

Die, cutting dimensions, tolerance (mm)				Heat treatment	Sym.	Revision	Date	Sign	Checked
New, change, replace	Nominal size	Class1	Class2	Class3	Finish	▽▽▽▽▽▽			
	~<4	±0.06	±0.10	±0.20	Surface treatment				
	4<~≤16	±0.07	±0.15	±0.30	Rubber hardness				
	16<~≤63	±0.10	±0.25	±0.40	Surface roughness				
Press bend angle, tolerance	Class1	Class2	Class3	Color					
Bend angle	Class1	Class2	Class3	Post treatment					
Square bending	±1.0	±1.5	2.50<~≤4.00	±0.25	±0.65	±0.80			
Other bending	±1.5	±2.0	4.00~	±0.30	±0.80	±1.20			

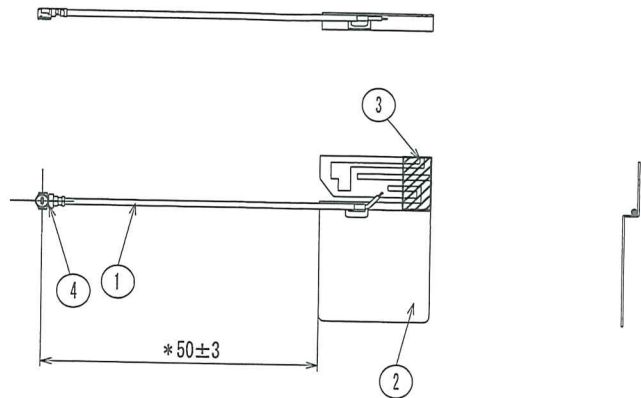

4	CONNECTOR	1	MHF 20278-112R-13	DAI-ICHI SEIKO CO., LTD.
3	PROTECTION TAPE	1	No. 631S #25 WHITE	TERACKA CO., LTD.
2	SHEET METAL	1	ST-S ZE-36 t0.3 (ANT1151-AB)	NISSEI ELECTRIC CO., LTD.
1	CABLE	1	RF-MF50161C GRAY	NISSEI ELECTRIC CO., LTD.
LTR	PART NAME	QTY	MATERIAL	REMARK
Size A3		Material	DWG. Name ANT1722-161CG/M-AB	
Approved	140310 N. KAKEI	Remarks	E0A43040	Specification No. H5C1722
Checked	140310 M. IKEDA			
Designed	140310 T. ITO	Scale Free	Qty	DWG. No. ANTP0372-C0473-0
Drawn	140310 T. ITO			



New, change, replace	Die, cutting dimensions, tolerance (mm)				Heat treatment	Sym.	Revision	Date	Sign	Checked
	Nominal size	Class1	Class2	Class3						
	~ < 4	±0.06	±0.10	±0.20	Finish	▽▽▽▽				
	4 < ~ ≤ 16	±0.07	±0.15	±0.30	Surface treatment					
	16 < ~ ≤ 63	±0.10	±0.25	±0.40	Rubber hardness					
	Press bend angle, tolerance	63 < ~ ≤ 120	±0.15	±0.35	Surface roughness					
	Bend angle	Class1	Class2	120 < ~ ≤ 250	Color					
	Square bending	±1	±1.5	250 < ~ ≤ 400	Post treatment					
	Other bending	±1.5	±2.0	400 ~						

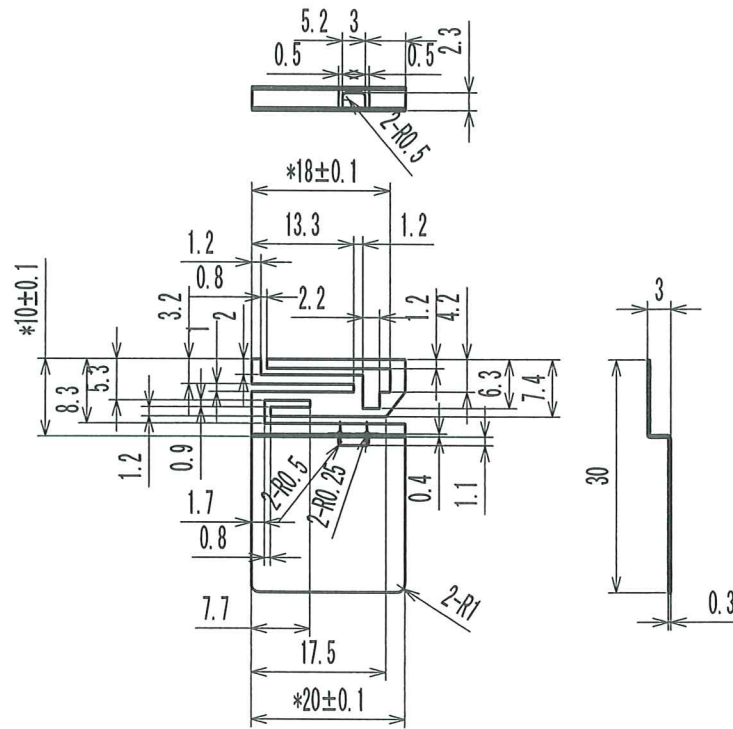

Size A4		Material ST-S ZE-36 t0.3		DWG. Name ANT1151-AB	
Approved	140310	N. KAKEI	Remarks	Type	Specification No. H5C1151
Checked	140310	M. IKEDA			
Designed	140310	T. ITO			
Drawn	140310	T. ITO			
		Scale Free Qty 1		DWG No.	