

CMN-851 Installation Manual

CAUTION

Changes or modifications not expressly approved by the party responsible for compliance could void the user's authority to operate the equipment.

1. Compliance statement and notification

<FCC / IC>

Declaration of Conformity

Product Name: WLAN Module

Model Number: CMN-851

This device complies with Part 15 of FCC Rules and RSS-Gen of IC Rules. Operation is subject to the following two conditions:

- (1) this device may not cause harmful interference, and
- (2) this device must accept any interference, including interference that may cause undesired operation of this device.

RF exposure compliance:

This equipment complies with FCC/IC radiation exposure limits set forth for an uncontrolled environment and meets the FCC radio frequency (RF) Exposure Guidelines in Supplement C to OET65 and RSS-102 of the IC radio frequency (RF) Exposure rules. This equipment has very low levels of RF energy that it deemed to comply without maximum permissive exposure evaluation (MPE) . But it is desirable that it should be installed and operated keeping the radiator at least 20cm or more away from person's body (excluding extremities: hands, wrists, feet and ankles) .

< FCC >

NOTE: This equipment has been tested and found to comply with the limits for a Class B digital device, pursuant to part 15 of the FCC Rules. These limits are designed to provide reasonable protection against harmful interference in a residential installation. This equipment generates, uses and can radiate radio frequency energy and, if not installed and used in accordance with the

instructions, may cause harmful interference to radio communications. However, there is no guarantee that interference will not occur in a particular installation. If this equipment does cause harmful interference to radio or television reception, which can be determined by turning the equipment off and on, the user is encouraged to try to correct the interference by one or more of the following measures:

- Reorient or relocate the receiving antenna.
- Increase the separation between the equipment and receiver.
- Connect the equipment into an AC outlet on a circuit different from that to which the receiver is connected.
- Consult the dealer or an experienced radio/TV technician for help.

In accordance with 47 CFR Part 15.407 (e) U-NII devices operating in 5.15-5.25GHz frequency bands are restricted to indoor operations only.

This transmitter must not be co-located or operated in conjunction with any other antenna or transmitter.

This device is slave equipment, the device is not radar detection and not ad-hoc operation in the DFS band.

End Product Labeling

This transmitter module is authorized only for use in device where the antenna may be installed such that 20cm may be maintained between the antenna and users. The final end product must be labeled in a visible area with the following: "Contains FCC ID: CKECMN851"

< IC >

Canada, Industry Canada (IC) Notices

This Class B digital apparatus complies with Canadian ICES-003 and RSS-210.

Operation is subject to the following two conditions: (1) this device may not cause interference, and (2) this device must accept any interference, including interference that may cause undesired operation of the device.

Radio Frequency (RF) Exposure Information

The radiated output power of the Wireless Device is below the Industry Canada (IC) radio frequency exposure limits. The Wireless Device should be used in such a manner such that the potential for human contact during normal operation is minimized.

This device has also been evaluated and shown compliant with the IC RF Exposure limits under mobile exposure conditions. (antennas are greater than 20cm from a person's body).

This device has been certified for use in Canada. Status of the listing in the Industry Canada's REL (Radio Equipment List) can be found at the following web address:

<http://www.ic.gc.ca/app/sitt/reltel/srch/nwRdSrch.do?lang=eng>

Additional Canadian information on RF exposure also can be found at the following web address:

<http://www.ic.gc.ca/eic/site/smt-gst.nsf/eng/sf08792.html>

Canada, avis d'Industry Canada (IC)

Cet appareil numérique de classe B est conforme aux normes canadiennes ICES-003 et RSS-210. Son fonctionnement est soumis aux deux conditions suivantes : (1) cet appareil ne doit pas causer d'interférence et (2) cet appareil doit accepter toute interférence, notamment les interférences qui peuvent affecter son fonctionnement.

Informations concernant l'exposition aux fréquences radio (RF)

La puissance de sortie émise par l'appareil de sans fil est inférieure à la limite d'exposition aux fréquences radio d'Industry Canada (IC). Utilisez l'appareil de sans fil de façon à minimiser les contacts humains lors du fonctionnement normal.

Ce périphérique a également été évalué et démontré conforme aux limites d'exposition aux RF d'IC dans des conditions d'exposition à des appareils mobiles (les antennes se situent à moins de 20 cm du corps d'une personne).

Ce périphérique est homologué pour l'utilisation au Canada. Pour consulter l'entrée correspondant à l'appareil dans la liste d'équipement radio (REL - Radio Equipment List) d'Industry Canada rendez-vous sur:

<http://www.ic.gc.ca/app/sitt/reltel/srch/nwRdSrch.do?lang=eng>

Pour des informations supplémentaires concernant l'exposition aux RF au Canada rendez-vous sur :

<http://www.ic.gc.ca/eic/site/smt-gst.nsf/eng/sf08792.html>

Information to Be Supplied to the End User by the OEM or Integrator

The following regulatory and safety notices must be published in documentation supplied to the end user of the product or system incorporating an adapter in compliance with local regulations.

Host system must be labeled with "Contains IC: 768B-CMN851 "

This radio transmitter IC: 768B-CMN851 has been approved by Industry Canada to operate with the antenna types listed below with the maximum permissible gain and required antenna impedance for each antenna type indicated. Antenna types not included in this list, having a gain greater than the maximum gain indicated for that type, are strictly prohibited for use with this device.

Antenna List

No.	Manufacturer	Part No.	Antenna Type	Peak Gain
1	TAIYO YUDEN	AH 104N2450D1	Chip Antenna	2.1dBi in 2.4GHz 2.4dBi in 5GHz

Note: The Cable (I-pex type) connects WLAN module and Chip antenna.

<R&TTE>

CE Marking:



Please describe the following sentences to the label or the user manual of the product in each language in the sales country:

Hereby, *Japan Radio CO., Ltd.* declares that this CMN-851 is in compliance with the essential requirements and other relevant provisions of Directive 1999/5/EC.

2. Hardware Specification

2.1 Radio Specification

Table 2-1 Radio Specification

ITEM	Descriptions	
Communication Standard	IEEE802.11b/g/n	IEEE802.11a/n
Access Control	CSMA/CA	
Frequency Band and Operating Channels	U.S.A : 2412~2462MHz 11 channels (1~11) Canada : 2412~2462MHz 11 channels (1~11) Europe : 2412~2472MHz 13 channels (1~13) Japan : 2412~2472MHz 13 channels (1~13)	U.S.A : 5180-5320MHz 5500 – 5700MHz 19 channels Canada : 5180-5320MHz 5500 – 5700MHz 19 channels Europe : 5180-5320MHz 5500 – 5700MHz 19 channels Japan : 5180-5320MHz 5500 – 5700MHz 19 channels
Channel Space	5MHz	20MHz
Modulation	DSSS / OFDM	OFDM
Data Rates Supported	802.11b : 1,2,5.5,11Mbps 802.11g : 6,9,12,18,24,36 ,48,54Mbps 802.11n : HT20/40, MCS0~15	802.11b : 1,2,5.5,11Mbps 802.11g : 6,9,12,18,24,36 ,48,54Mbps 802.11n : HT20/40, MCS0~15
Antenna Connectors	U.FL or equivalent, 2pcs.	

2.2 Power Supply

Table 2-2 Power Supply

PARAMETER	MIN	TYP	MAX	UNIT	COMMENTS
Supply Voltage (Vcc)	3.13	3.3	3.47	V	Supply regulated voltage
Operating Current	-	0.74	0.93	A	Condition: Vcc=3.3V

2.3 Host Interface

2.3.1 Electrical Interface

PCI-express mini-card Rev1.1

2.3.2 Host Interface connector pin layout

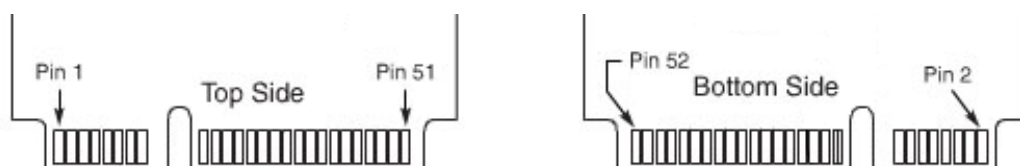

Fig.1 Host Interface Connector pin layout

2.3.3 Pin assignment and signal descriptions

Pin No.	Signal name	Signal type	Descriptions
1	#WAKE	OD	-PCIe service a function-initiated wake up event request -Open Drain Output
2	3.3Vaux		
3	COEX1	I/O	
4	GND		
5	COEX2	I/O	
6	1.5V		NC
7	CLKREQ#	OD	PCIE reference clock request
8	UIM_PWR		NC
9	GND		
10	UIM_DATA		NC
11	REFCLK-	I	PCIE differential reference clock(100MHz)
12	UIM_CLK		NC
13	REFCLK+	I	PCIE differential reference clock (100MHz)
14	UIM_RESET		NC
15	GND		
16	UIM_VPP		NC
17	Reserved UIM_C8)		NC
18	GND		
19	Reserved UIM_C4)		NC
20	W_DISABLE#	IH/OH	
21	GND		
22	RESET#	IH	PCIE reset
23	PERn0	O	PCIE Differential transmit
24	3.3Vaux		
25	PERp0	O	PCIE Differential transmit

Pin No.	Signal name	Signal type	Descriptions
26	GND		
27	GND		GND
28	+1.5V		NC
29	GND		GND
30	SMB_CLK		NC
31	PETn0	I	PCIE Differential receive
32	SMB_DATA		NC
33	PETp0		PCIE Differential receive
34	GND		GND
35	GND		NC
36	USB D-		NC
37	GND		GND
38	USB D+		NC
39	3.3Vaux		
40	GND		GND
41	3.3Vaux		
42	LED_WWAN#		NC
43	GND		
44	LED_WLAN#	IH/OH	
45	Reserved		NC
46	LED_WPAN#		NC
47	Reserved		NC
48	+1.5V		NC
49	Reserved		NC
50	GND		GND
51	Reserved		NC
52	3.3Vaux		

Signal type	Description
I	Input
O	Output
OD	Open Drain
H	Pull up

2.4 Environmental Conditions

ITEM	MIN	TYP	MAX	UNIT	COMMENTS
Operating Temperature	0		+50	degC	
Operating Humidity	20		95	%Rh	Non condensing

2.5 Mechanical Specification

Size : 30(W)x26.8(D)x4.75(H)mm

Weight : Approx. 5g

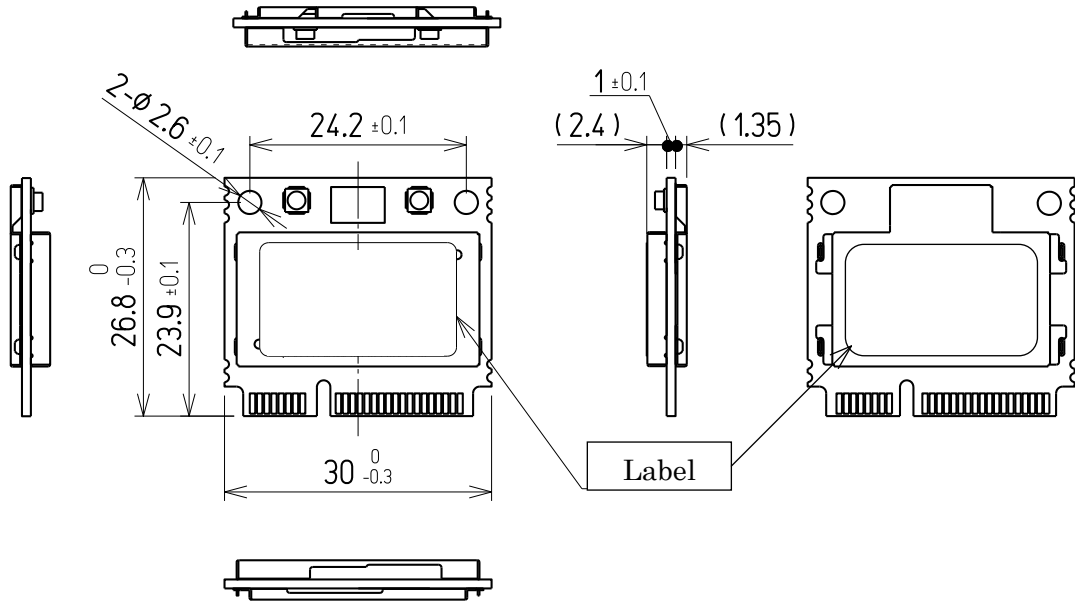
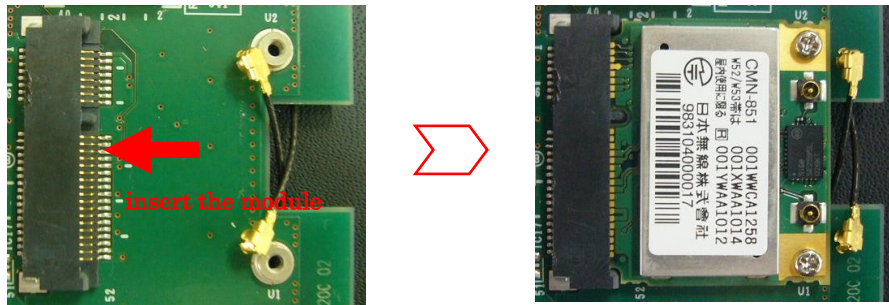

Fig.2- Outline Drawing

3. Installation

(1) Please insert the module in the host side connector firmly.



(2) Please connect the antenna cables with ANT-A and ANT-B

