



SAR TEST REPORT

Test Report No. : 10015814H-A

Applicant : Toshiba Corporation
Type of Equipment : Wireless Network Adapter
Model No. : 7260NGW
FCC ID : CJ6UPA5125WB
Test regulation : FCC47CFR 2.1093
FCC OET Bulletin 65, Supplement C (Edition 01-01)
Test Result : Complied
Reported SAR(1g) Value : FCC Part15.247(WLAN 11b/g/n(2.4GHz band), 11a/n/ac(5.8GHz band)
Body : 0.641W/kg
FCC Part15.407(WLAN 11a/n/ac(5.2GHz band, 5.3GHz band, 5.6GHz band)
Body : 0.666W/kg

The highest reported SAR(1g) Value for the device is 0.666 W/kg.
Simultaneous transmission test was excluded.

The highest sum of SAR(1g) for the simultaneous transmitting antennas Value for the device is 0.833 W/kg.

1. This test report shall not be reproduced in full or partial, without the written approval of UL Japan, Inc.
2. The results in this report apply only to the sample tested.
3. This sample tested is in compliance with the limits of the above regulation.
4. The test results in this report are traceable to the national or international standards.
5. This test report must not be used by the customer to claim product certification, approval, or endorsement by NVLAP, NIST, or any agency of the Federal Government.

Date of test: May 29 to June 13, 2013

Representative
test engineer:

Hisayoshi Sato
Engineer of WiSE Japan,
UL Verification Service

Approved by :

Takahiro Hatakeda
Leader of WiSE Japan
UL Verification Service



NVLAP LAB CODE: 200572-0

This laboratory is accredited by the NVLAP LAB CODE 200572-0, U.S.A. The tests reported herein have been performed in accordance with its terms of accreditation. *As for the range of Accreditation in NVLAP, you may refer to the WEB address, <http://www.ul.com/japan/jpn/pages/services/emc/about/mark1/index.jsp#nvlap>

CONTENTS	PAGE
SECTION 1: Customer information	4
SECTION 2: Equipment under test (E.U.T.)	4
2.1 Identification of EUT	4
2.2 Product Description.....	4
SECTION 3: Test standard information	5
3.1 Test Specification.....	5
3.2 Procedure	5
3.3 Exposure limit	6
3.4 Test Location	6
SECTION 4: Test result	7
4.1 Stand-alone SAR result	7
4.2 Simultaneous transmission SAR result.....	8
SECTION 5: Description of the operating mode	9
5.1 Output power operating modes	9
5.2 Confirmation before SAR testing (Output power measurement results).....	13
5.3 SAR testing operating modes	24
5.4 Confirmation after SAR testing.....	26
SECTION 6 SAR test exclusion considerations	27
6.1 Standalone SAR test exclusion considerations.....	27
SECTION 7: Description of the Body setup	30
7.1 Description of the Body setup	30
SECTION 8: Test surrounding	32
8.1 Measurement uncertainty	32
SECTION 9: Measurement results	34
9.1 WLAN Body SAR (2.4G).....	34
9.2 WLAN Body SAR (5G).....	36
SECTION 10: Simultaneous transmission SAR test exclusion considerations	44
10.1 Estimated SAR is calculated about Bluetooth.....	44
10.2 Result of $\sum \Sigma$ SAR _{1g} of Body	45
SECTION 11 Test instruments	46
APPENDIX 1: SAR Measurement data	47
1. Evaluation procedure	47
2. Measurement data	48
APPENDIX 2: System Validation	154
1. System validation result Body 2450.....	154
2. System validation result Body 5GHz.....	156
3. System Validation Dipole (D2450V2,S/N:713).....	165
4. System Validation Dipole (D5GHzV2,S/N:1020)	176
5. Validation uncertainty	189
APPENDIX 3: System specifications	190
1. Configuration and peripherals	190
2. Specifications	191
3. Dosimetric E-Field Probe Calibration (EX3DV4, S/N: 3825)	196
APPENDIX 4: Photographs of test setup	207
1. Photographs of EUT.....	207
2. Photographs of host device	207
3. Antenna location	210

SECTION 1: Customer information

Company Name : Toshiba Corporation
Address : Digital Products & Services Company, 2-9, Suehiro-cho, Ome-shi, Tokyo
198-8710, Japan
Telephone Number : + 81-42-834-4540
Facsimile Number : +81-42-830-7331
Contact Person : Toshiyuki Echigo

SECTION 2: Equipment under test (E.U.T.)

2.1 Identification of EUT

Type of Equipment	Wireless LAN module
Model Number	7260NGW
Serial Number	PA5125U-1MPC
Condition of EUT	7260NGW: Production model *. Used platform (Tablet/Laptop compatible PC: Production prototype (*. Not for sale: This sample is equivalent to mass-produced items.)
Receipt Date of Sample	May 20, 2013 (*. No modification by the Lab.)
Category Identified	The antenna portion of the EUT is located and used from a human body at a less than 20cm. *. Since the platform may contact and/or very close to a human body during Wi-Fi operation, the localized SAR (trunk) was evaluated.
Feature of EUT	The EUT is a Wireless LAN module installed into to the platform of tablet PC with laptop keyboard base station.
SAR accessory	none

2.2 Product Description

Radio Specification

Equipment type	Transceiver		
Power rating	DC 3.3V, *.The dc power is supplied from the constant voltage circuit of the main body of the EUT.		
Q'ty of Antenna	2 pcs. (Main antenna and Aux antenna)		
Operation specification	Main antenna	Aux antenna	
Operation mode	Wi-Fi	WiFi	Bluetooth
Frequency of operation	2412-2462MHz (11b,g,n(20MHz)) / 2422-2452MHz (11n(40MHz)); W52 band: 5180-5240MHz (11a,n(20MHz),ac(20MHz)) / 5190-5230MHz (11n(40MHz),ac(40MHz)) / 5210MHz (11ac(80MHz)); W53 band: 5260-5320MHz (11a,n(20MHz),ac(20MHz)) / 5270-5310MHz (11n(40MHz),ac(40MHz)) / 5290MHz (11ac(80MHz)); W56 band: 5500-5700MHz (11a,n(20MHz),ac(20MHz)) / 5510-5670MHz (11n(40MHz),ac(40MHz)) / 5530-5690MHz (11ac(80MHz)), in addition; 5720MHz (11ac(20MHz)), 5710MHz (11ac(40MHz))		2402-2480MHz
Channel spacing	5MHz (2.45GHz band), 20MHz (W52, W53, W56 band)		1MHz (BR, EDR), 2MHz (Low Energy)
Type of modulation	DSSS: DBPSK, DQPSK, CCK OFDM: BPSK, QPSK, 16QAM, 64QAM, (256QAM (*.11ac alone))		FHSS: GFSK, $\pi/4$ - DQPSK, 8DPSK
Antenna specification	Main antenna	Aux antenna	
Antenna type	PIFA (Planar Inverted F Antenna)		PIFA (Planar Inverted F Antenna)
Model name	Main Ant. (P/N: APP6P-70700781)		Aux Ant. (P/N: APP6P-70700782)
Antenna connector type	RF module side: W.FL (Hirose) / Antenna side: soldered.		RF module side: W.FL (Hirose) / Antenna side: soldered.
Cable type / length	OD 1.13 RF cable / 100mm		OD 1.13 RF cable / 100mm
Antenna gain (Peak, with cable loss.)	-0.63 dBi (2400-2500MHz), -0.71 dBi (5150-5350MHz), -1.43 dBi (5470-5725MHz)		-3.39 dBi (2400-2500MHz), 0.12 dBi (5150-5350MHz), -1.51 dBi (5470-5725MHz)
Transmit power	*. Refers to section 5 in this report.		

*.The EUT do not use the special transmitting technique such as "beam-forming" and "time-space code diversity."

*With the antenna Aux, the Wi-Fi operation and the Bluetooth operation can be transmitted simultaneously.

*5600MHz-5650MHz is not used in Canada.

SECTION 3 : Test standard information

3.1 Test Specification

Title : **Supplement C (Edition 01-01) to OET Bulletin 65 (Edition 97-01):**

Supplement C (Edition 01-01) - Additional Information for Evaluating Compliance of Mobile and Portable Devices with FCC Limits for Human Exposure to Radiofrequency Emissions
OET Bulletin 65 (Edition 97-01) - Evaluating Compliance with FCC Guidelines for Human Exposure to Radiofrequency Electromagnetic Fields

: **IEEE Std 1528-2003:**

IEEE Recommended Practice for Determining the Peak Spatial-Average Specific Absorption Rate (SAR) in the Human Head from Wireless Communications Devices: Measurement Techniques Supplement C

In additions;

- KDB450824D01(v01r01)** SAR Prob Cal and Ver Meas
- KDB450824D02(v01r01)** Dipole SAR Validation Verification
- KDB447498D01(v05)** Mobile and Portable Device RF Exposure Procedures and Equipment Authorization Policies
- KDB447498D02(v02)** SAR Measurement Procedures for USB Dongle Transmitters
- KDB648474D04(v01)** SAR Evaluation Considerations for Wireless Handsets
- KDB941225D01(v02)** SAR Measurement Procedures for 3G Devices
- KDB941225D02(v02v01)** 3GPP R6 HSPA and R7 HSPA+ SAR Guidance
- KDB941225D03(v01)** Recommended SAR Test Reduction Procedures for GSM/GPRS/EDGE
- KDB941225D04(v01)** Evaluating SAR for GSM/(E)GPRS Dual Transfer Mode
- KDB941225D05(v02)** SAR for LTE Devices
- KDB941225D06(v01)** SAR test procedures for devices incorporating SAR Evaluation Procedures for Portable Devices with Wireless Router Capabilities (Hot Spot SAR)
- KDB941225D07(v01)** SAR Evaluation Procedures for UMPC Mini-Tablet Devices
- KDB 616217D04(v01)** SAR Evaluation Considerations for Laptop, Notebook, Netbook and Tablet Computers
- KDB865664D01(v01)** SAR Measurement Requirements for 100MHz to 6 GHz
- KDB248227D01(v01r02)** SAR Measurement Procedures for 802.11a/b/g Transmitters

Reference

- [1]ANSI, ANSI/IEEE C95.1-1992: IEEE Standard for Safety Levels with Respect to Human Exposure to Radio Frequency Electromagnetic Fields, 3 kHz to 300 GHz, The Institute of Electrical and Electronics Engineers, Inc., New York, NY 10017, 1992.
[2]SPEAG uncertainty document (AN 15-7/AN19-17) for DASY 5 System from SPEAG (Shimid & Partner Engineering AG).

3.2 Procedure

Transmitter	WLAN	Bluetooth
Test Procedure	FCC OET BULLETIN 65, SUPPLEMENT C SAR	Exemption*
Category	FCC47CFR 2.1093	FCC47CFR 2.1093
Note: UL Japan, Inc.'s SAR Work Procedures 13-EM-W0429 and 13-EM-W0430		

* Since SAR exclusion threshold conditions are corresponded by KDB 447498 D01, an SAR test is not required. Refer to Section 6.

3.3 Exposure limit

(A) Limits for Occupational/Controlled Exposure (W/kg)

Spatial Average (averaged over the whole body)	Spatial Peak (averaged over any 1g of tissue)	Spatial Peak (hands/wrists/feet/ankles averaged over 10g)
0.4	8.0	20.0

(B) Limits for General population/Uncontrolled Exposure (W/kg)

Spatial Average (averaged over the whole body)	Spatial Peak (averaged over any 1g of tissue)	Spatial Peak (hands/wrists/feet/ankles averaged over 10g)
0.08	1.6	4.0

Occupational/Controlled Environments: are defined as locations where there is exposure that may be incurred by people who are aware of the potential for exposure, (i.e. as a result of employment or occupation).

General Population/Uncontrolled Environments: are defined as locations where there is the exposure of individuals who have no knowledge or control of their exposure.

**NOTE:GENERAL POPULATION/UNCONTROLLED EXPOSURE
SPATIAL PEAK(averaged over any 1g of tissue) LIMIT
1.6 W/kg**

3.4 Test Location

*Shielded room for SAR testings

UL Japan, Inc. Head Office EMC Lab. *NVLAP Lab. code: 200572-0
4383-326 Asama-cho, Ise-shi, Mie-ken 516-0021 JAPAN
Telephone : +81 596 24 8999 Facsimile : +81 596 24 8124

SECTION 4 : Test result

4.1 Stand-alone SAR result

Stand-alone SAR Procedure

No.	Capable Tx configurations		Head SAR	Body-worn SAR	Body SAR	Product specific (Hotspot)	Note
1	WLAN	WLAN 2.4GHz band	-	-	Yes	-	-
2		WLAN 5GHz band	-	-	Yes	-	-
3	Bluetooth	Bluetooth BDR/EDR/LE	Exemption*1				

Reported SAR

Measured SAR is scaled to the maximum tune-up tolerance limit by the following formulas.

Reported SAR= Maximum tune-up tolerance limit [mW] / Measured maximum power [mW] · Measured SAR [W/kg]

1g Body SAR

Mode	Measured maximum power [mW]*2	Maximum tune-up tolerance limit [mW]	Measured SAR [W/kg]	Reported SAR [W/kg]
WLAN 2.4GHz band	42.07	44.36	0.608	0.641
WLAN 5.2GHz band	35.56	39.81	0.595	0.666
WLAN 5.3GHz band	18.77	77.27	0.576	0.591
WLAN 5.6GHz band	40.09	43.95	0.510	0.559
WLAN 5.8GHz band	43.25	43.85	0.631	0.640
Bluetooth	-*1			

Note

*1 Since SAR exclusion threshold conditions are corresponded by KDB 447498 D01, and SAR test is not required.

Refer to Section 6

*2 The sample used by the SAR test is within the tune-up tolerance but not more than 2 dB lower than the maximum tune-up tolerance limit. That is, measured maximum power is included the tune-up tolerance range.

4.2 Simultaneous transmission SAR result

<Simultaneous Procedure>

This EUT has the unlicensed transmitter such as WLAN (802.11a/b/g/n) & Bluetooth devices, and the following simultaneous transmission is possible.

No.	Capable Tx configurations	Head SAR	Body SAR	Note
4	WLAN Main ant + Bluetooth ant(Shared WLAN Aux ant)	-	Yes	

Simultaneous transmission SAR

<WLAN + Bluetooth >

Simultaneous transmitter evaluation based on the KDB447498D01 Refer to the clause 4.3.2..

Step1	Standalone SAR test exclusion considerations. Refer to Section 6.
Step2	Measured Stand-alone SAR for WLAN Main ant.
Step3	No measured Stand-alone SAR for Bluetooth.
Step4	Simultaneous transmission is possible (WLAN Main ant + Bluetooth) Simultaneous transmission SAR test exclusion considerations.
Step5	Estimated SAR for Bluetooth is calculated.
Step6	1.6W/kg > \sum 1g SAR (WWAN + Bluetooth) Body: 0.833 W/kg Refer to Section 10
Step6	No simultaneous transmission.

SECTION 5 : Description of the operating mode

5.1 Output power operating modes

WLAN*1

Mode	Duty cycle	Frequency Band	Test Frequency	Modulation	
IEEE802.11b	100%	2412-2462MHz	2412MHz (1ch) 2437MHz(6ch) 2462MHz(11ch)	DSSS (DBPSK.DQPSK.CCK)	
IEEE802.11g	100%	2412-2462MHz	2412MHz (1ch) 2437MHz(6ch) 2462MHz(11ch)		
IEEE802.11n20 (2.4G)	100%	2412-2462MHz	2412MHz (1ch) 2437MHz(6ch) 2462MHz(11ch)		
IEEE802.11n40 (2.4G)	100%	2412-2462MHz	2422MHz (3ch) 2437MHz(6ch) 2462MHz(11ch)		
IEEE802.11a	100%	5180-5240MHz	All channel		
	100%	5260-5320MHz	All channel		
	100%	5500-5700MHz	All channel		
	100%	5745-5825MHz	All channel		
IEEE802.11n20 (5G)	100%	5180-5240MHz	All channel		OFDM (BPSK, QPSK, 16QAM, 64QAM, 256QAM)
	100%	5260-5320MHz	All channel		
	100%	5500-5700MHz	All channel		
	100%	5745-5825MHz	All channel		
IEEE802.11n40 (5G)	100%	5190-5230MHz	All channel		
	100%	5270-5310MHz	All channel		
	100%	5510-5670MHz	All channel		
	100%	5755-5795MHz	All channel		
IEEE802.11ac20 (5G)	100%	5720MHz	All channel		
IEEE802.11ac40 (5G)	100%	5710MHz	All channel		
IEEE802.11ac80 (5G)	100%	5210MHz 5290MHz 5530-5690MHz 5775MHz	All channel		

Setting

WLAN

*Power of the EUT was set by the software as follows;

Software: DRTU Version 1.6.1-579

Power settings: See clause 5.2.

*This setting of software is the worst case.

Any conditions under the normal use do not exceed the condition of setting.

In addition, end users cannot change the settings of the output power of the product.

WLAN Maximum tune-up tolerance limit

The below table is power data of the original report*. Refer to the power data indicated in the original report of EUT for this report.

* Refer to page 16 to 18 in the original report(Company Name: Intel Corporation, Test report Number: SAR.20130203).

Band	Mode	Bandwidth (MHz)	Channel	Frequency (MHz)	Antenna	Maximum tune-up tolerance limit (dBm)
2450MHz	802.11b	20	1	2412	Main	15.47
			6	2437		15.50
			11	2462		15.48
			1	2412	AUX	13.98
			6	2437		14.00
			11	2462		13.99
	802.11g	20	1	2412	Main	13.48
			6	2437		16.50
			11	2462		13.47
			1	2412	AUX	11.99
			6	2437		15.49
			11	2462		13.46
	802.11n	20	1	2412	Main	13.48
			6	2437		16.50
			11	2462		13.46
			1	2412	AUX	11.97
6			2437	15.50		
11			2462	13.42		
802.11n	40	3	2422	Main	11.96	
		6	2437		16.47	
		9	2452		12.90	
		3	2422	AUX	9.92	
		6	2437		13.42	
		9	2452		12.89	
15-5.25GHz	802.11a	20	36	5180	Main	13.46
			40	5200		15.86
			44	5220		16.00
			48	5240		14.98
			36	5180	AUX	12.89
			40	5200		15.92
			44	5220		16.00
			48	5240		14.96
	802.11n	20	36	5180	Main	13.42
			40	5200		15.87
			44	5220		16.00
			48	5240		15.48
			36	5180	AUX	12.86
			40	5200		15.91
			44	5220		16.00
			48	5240		15.46
802.11n	40	38	5190	Main	9.46	
		46	5230		15.42	
		38	5190	AUX	9.94	
		46	5230		15.37	
802.11ac	80	42	5210	Main	8.46	
				AUX	8.39	
25-5.35GHz	802.11a	20	52	5260	Main	13.45
			56	5280		15.87
			60	5300		16.00
			64	5320		13.46
			52	5260	AUX	12.90
			56	5280		15.93
			60	5300		16.00
			64	5320		12.94
	802.11n	20	52	5260	Main	13.42
			56	5280		15.81
			60	5300		15.94
			64	5320		13.48
			52	5260	AUX	12.85
			56	5280		15.93
			60	5300		15.85
			64	5320		13.00
	802.11n	40	54	5270	Main	9.48
			62	5310		11.00
			54	5270	AUX	9.99
			62	5310		10.97
802.11ac	80	58	5290	Main	10.47	
				AUX	10.92	

Band	Mode	Bandwidth (MHz)	Channel	Frequency (MHz)	Antenna	Maximum tune-up tolerance limit (dBm)			
5600MHz	802.11a	20	100	5500	Main	13.46			
			104	5520		16.42			
			108	5540		16.39			
			112	5560		16.50			
			116	5580		16.48			
			120	5600		16.42			
			124	5620		16.46			
			128	5640		16.37			
			132	5660		16.50			
			136	5680		16.47			
			140	5700		12.93			
			100	5500		AUX	12.95		
			104	5520			16.42		
			108	5540			16.38		
			112	5560	16.50				
			116	5580	16.43				
			120	5600	16.48				
			124	5620	16.42				
			128	5640	16.40				
			132	5660	16.50				
			136	5680	16.38				
			140	5700	12.42				
			802.11n	20	100		5500	Main	13.50
					104		5520		16.42
					108		5540		16.48
					112	5560	16.45		
					116	5580	16.37		
					120	5600	16.48		
	124	5620			16.50				
	128	5640			16.41				
	132	5660			16.45				
	136	5680			16.39				
	140	5700			12.98				
	100	5500			AUX	12.99			
	104	5520				16.34			
	108	5540				16.39			
	112	5560				16.41			
	116	5580				16.50			
	120	5600				16.42			
	124	5620				16.48			
	128	5640				16.43			
	132	5660				16.47			
	136	5680				16.48			
	140	5700				12.49			
	802.11n	40				102	5510	Main	10.42
						110	5550		16.48
						118	5580		16.42
					126	5610	16.47		
					134	5670	15.49		
					102	5510	10.48		
			110	5550	16.48				
			118	5580	AUX	16.43			
			126	5610		16.38			
			134	5670		15.46			
			802.11ac	20		144	5720	Main	16.48
								AUX	16.42
				40		142	5710	Main	16.43
								AUX	16.47
	80	106		5530	Main	8.97			
		122		5610		13.95			
		138	5690	13.92					
		106	5530	AUX		8.91			
	122	5610	13.97						
	138	5690	13.99						

Band	Mode	Bandwidth (MHz)	Channel	Frequency (MHz)	Antenna	Maximum tune-up tolerance limit (dBm)	
5800MHz	802.11a	20	149	5745	Main	16.48	
			153	5765		16.47	
			157	5785		16.50	
			161	5805		16.43	
			165	5825		16.38	
			149	5745	AUX	16.42	
			153	5765		16.45	
			157	5785		16.50	
			161	5805		16.47	
			165	5825		16.49	
	802.11n	20	20	149	5745	Main	16.42
				153	5765		16.45
				157	5785		16.48
				161	5805		16.43
				165	5825		16.41
				149	5745	AUX	16.40
				153	5765		16.48
				157	5785		16.39
				161	5805		16.47
				165	5825		16.45
	802.11n	40	40	151	5755	Main	16.43
				159	5795		16.37
				151	5755	AUX	16.36
				159	5795		16.42
802.11ac	80	80	155	5775	Main	13.98	
					AUX	14.00	

Bluetooth Maximum tune-up tolerance limit

BR-EDR: 6dBm

LE: 5dBm

5.2 Confirmation before SAR testing (Output power measurement results)

Power measurement in the mode which performed SAR measurement original report, and the mode which performed SAR measurement by the addition this report was performed.

1) WLAN (11b/g/n(2.4G))

IEEE802.11b 1Mbps Ant Main

Ch	Frequency [MHz]	P/M Reading AVG	Cable Loss [dB]	Atten. [dB]	Result		Power Setting
					[dBm] AVG	[mW] AVG	
6	2437	2.54	2.63	10.01	15.18	32.96	Auto

IEEE802.11b 1Mbps Ant Aux

Ch	Frequency [MHz]	P/M Reading AVG	Cable Loss [dB]	Atten. [dB]	Result		Power Setting
					[dBm] AVG	[mW] AVG	
6	2437	0.91	2.63	10.01	13.55	22.65	13.0

Sample Calculation:

Result = Reading + Cable Loss + Attenuator

IEEE802.11g 6Mbps Ant Main

Ch	Frequency [MHz]	P/M Reading AVG	Cable Loss [dB]	Atten. [dB]	Result		Power Setting
					[dBm] AVG	[mW] AVG	
6	2437	3.52	2.63	10.01	16.16	41.30	16.0

IEEE802.11g 6Mbps Ant Aux

Ch	Frequency [MHz]	P/M Reading AVG	Cable Loss [dB]	Atten. [dB]	Result		Power Setting
					[dBm] AVG	[mW] AVG	
6	2437	2.55	2.63	10.01	15.19	33.04	15.5

Sample Calculation:

Result = Reading + Cable Loss + Attenuator

IEEE802.11n20 HT4 Ant Main

Ch	Guard Interval	Frequency [MHz]	P/M Reading AVG	Cable Loss [dB]	Atten. [dB]	Result		Power Setting
						[dBm] AVG	[mW] AVG	
6	Long	2437	3.52	2.63	10.01	16.16	41.30	16.0

IEEE802.11n20 HT4 Ant Aux

Ch	Guard Interval	Frequency [MHz]	P/M Reading AVG	Cable Loss [dB]	Atten. [dB]	Result		Power Setting
						[dBm] AVG	[mW] AVG	
6	Long	2437	2.42	2.63	10.01	15.06	32.06	15.5

Sample Calculation:

Result = Reading + Cable Loss + Attenuator

IEEE802.11n40 HT4 Ant Main

Ch	Guard Interval	Frequency [MHz]	P/M Reading AVG	Cable Loss [dB]	Atten. [dB]	Result		Power Setting
						[dBm] AVG	[mW] AVG	
6	Long	2437	3.60	2.63	10.01	16.24	42.07	17.00

IEEE802.11n40 HT4 Ant Aux

Ch	Guard Interval	Frequency [MHz]	P/M Reading AVG	Cable Loss [dB]	Atten. [dB]	Result		Power Setting
						[dBm] AVG	[mW] AVG	
6	Long	2437	0.73	2.63	10.01	13.37	21.73	13.50

Sample Calculation:

Result = Reading + Cable Loss + Attenuator

IEEE802.11n20 HT8 Ant Main+Aux

Ch	Frequency [MHz]	Antenna	P/M Reading [dBm]	Cable Loss [dB]	Atten. [dB]	Result		Power Setting
						[dBm]	Total [dBm]	
6	2437	Main	3.35	2.63	10.01	15.99	18.90	17.0
		Aux	3.08	2.63	10.08	15.79		

Sample Calculation:

Result = Reading + Cable Loss + Attenuator

IEEE802.11n40 HT8 Ant Main+Aux

Ch	Frequency [MHz]	Antenna	P/M Reading [dBm]	Cable Loss [dB]	Atten. [dB]	Result		Power Setting
						[dBm]	Total [dBm]	
6	2437	Main	2.38	2.63	10.01	15.02	17.99	16.5
		Aux	2.22	2.63	10.08	14.93		

Sample Calculation:

Result = Reading + Cable Loss + Attenuator

2) WLAN (11a/n/ac(5180-5240MHz)):

IEEE802.11a 6Mbps Ant Main

Ch	Frequency [MHz]	P/M Reading AVG	Cable Loss [dB]	Atten. [dB]	Result		Power Setting
					[dBm] AVG	[mW] AVG	
44	5220	1.94	3.93	10.03	15.90	38.90	17.0

IEEE802.11a 6Mbps Ant Aux

Ch	Frequency [MHz]	P/M Reading AVG	Cable Loss [dB]	Atten. [dB]	Result		Power Setting
					[dBm] AVG	[mW] AVG	
44	5220	1.75	3.93	10.03	15.71	37.24	17.5

Sample Calculation:

Result = Reading + Cable Loss + Attenuator

IEEE802.11n20 HT4 Ant Main

Ch	Frequency [MHz]	P/M Reading AVG	Cable Loss [dB]	Atten. [dB]	Result		Power Setting
					[dBm] AVG	[mW] AVG	
40	5200	1.51	3.95	10.03	15.49	35.40	16.5
44	5220	1.55	3.93	10.03	15.51	35.56	16.5
48	5240	1.42	3.97	10.03	15.42	34.83	16.5

IEEE802.11n20 HT4 Ant Aux

Ch	Frequency [MHz]	P/M Reading AVG	Cable Loss [dB]	Atten. [dB]	Result		Power Setting
					[dBm] AVG	[mW] AVG	
44	5220	1.62	3.93	10.03	15.58	36.14	17.5

Sample Calculation:

Result = Reading + Cable Loss + Attenuator

IEEE802.11n40 HT4 Ant Main

Ch	Frequency [MHz]	P/M Reading AVG	Cable Loss [dB]	Atten. [dB]	Result		Power Setting
					[dBm] AVG	[mW] AVG	
46	5230	1.12	3.96	10.03	15.11	32.43	16.5

IEEE802.11n40 HT4 Ant Aux

Ch	Frequency [MHz]	P/M Reading AVG	Cable Loss [dB]	Atten. [dB]	Result		Power Setting
					[dBm] AVG	[mW] AVG	
38	5190	-4.07	3.95	10.03	9.91	9.79	11.0
46	5230	0.98	3.96	10.03	14.97	31.41	17.5

Sample Calculation:

Result = Reading + Cable Loss + Attenuator

IEEE802.11ac(80M) VHT6 Ant Main

Ch	Frequency [MHz]	S/A Reading AVG	Cable Loss [dB]	Atten. [dB]	Result		Power Setting
					[dBm] AVG	[mW] AVG	
42	5210	-5.94	3.96	10.03	8.05	6.38	8.5

IEEE802.11ac(80M) VHT6 Ant Aux

Ch	Frequency [MHz]	S/A Reading AVG	Cable Loss [dB]	Atten. [dB]	Result		Power Setting
					[dBm] AVG	[mW] AVG	
42	5210	-5.82	3.96	10.03	8.17	6.56	8.5

Sample Calculation:

Result = Reading + Cable Loss + Attenuator

IEEE802.11n20 HT8 Ant Main+Aux

Ch	Frequency [MHz]	Antenna	P/M Reading [dBm]	Cable Loss [dB]	Atten. [dB]	Result Total		Power Setting
						[dBm]	[dBm]	
44	5220	Main	2.16	3.95	10.03	16.14	18.81	17.5
		Aux	1.38	3.95	10.11	15.44		

Sample Calculation:

Result = Reading + Cable Loss + Attenuator

IEEE802.11n40 HT4 Ant Main+Aux

Ch	Frequency [MHz]	Antenna	P/M Reading [dBm]	Cable Loss [dB]	Atten. [dB]	Result Total		Power Setting
						[dBm]	[dBm]	
46	5230	Main	1.64	3.96	10.03	15.63	18.33	17.0
		Aux	0.92	3.96	10.11	14.99		

Sample Calculation:

Result = Reading + Cable Loss + Attenuator

IEEE802.11ac80 VHT6 Ant Main+Aux

Ch	Frequency [MHz]	Antenna	S/A Reading [dBm]	Cable Loss [dB]	Atten. [dB]	Result Total		Power Setting
						[dBm]	[dBm]	
42	5210	Main	-5.49	3.96	10.03	8.50	11.34	9.5
		Aux	-5.91	3.96	10.11	8.16		

Sample Calculation:

Result = Reading + Cable Loss + Attenuator

3) WLAN (11a/n/ac(5260-5320MHz):

IEEE802.11a 6Mbps Ant Main

Ch	Frequency [MHz]	P/M Reading AVG	Cable Loss [dB]	Atten. [dB]	Result		Power Setting
					[dBm] AVG	[mW] AVG	
60	5300	1.68	3.97	10.03	15.68	36.98	16.5

IEEE802.11a 6Mbps Ant Aux

Ch	Frequency [MHz]	P/M Reading AVG	Cable Loss [dB]	Atten. [dB]	Result		Power Setting
					[dBm] AVG	[mW] AVG	
56	5280	1.89	3.98	10.03	15.90	38.90	17.5
60	5300	1.95	3.97	10.03	15.95	39.36	17.5
64	5320	-1.29	3.98	10.03	12.72	18.71	13.5

Sample Calculation:

Result = Reading + Cable Loss + Attenuator

IEEE802.11n20 HT4 Ant Main

Ch	Frequency [MHz]	P/M Reading AVG	Cable Loss [dB]	Atten. [dB]	Result		Power Setting
					[dBm] AVG	[mW] AVG	
56	5280	1.82	3.98	10.03	15.83	38.28	17.0
60	5300	1.88	3.97	10.03	15.88	38.73	16.5
64	5320	-0.88	3.98	10.03	13.13	20.56	14.0

IEEE802.11n20 HT4 Ant Aux

Ch	Frequency [MHz]	P/M Reading AVG	Cable Loss [dB]	Atten. [dB]	Result		Power Setting
					[dBm] AVG	[mW] AVG	
56	5280	1.61	3.98	10.03	15.62	36.48	17.5

Sample Calculation:

Result = Reading + Cable Loss + Attenuator

IEEE802.11n40 HT4 Ant Main

Ch	Frequency [MHz]	P/M Reading AVG	Cable Loss [dB]	Atten. [dB]	Result		Power Setting
					[dBm] AVG	[mW] AVG	
62	5310	-3.25	3.99	10.03	10.77	11.94	11.50

IEEE802.11n40 HT4 Ant Aux

Ch	Frequency [MHz]	P/M Reading AVG	Cable Loss [dB]	Atten. [dB]	Result		Power Setting
					[dBm] AVG	[mW] AVG	
62	5310	-3.35	3.99	10.03	10.67	11.67	12.00

Sample Calculation:

Result = Reading + Cable Loss + Attenuator

IEEE802.11ac(80M) VHT6 Ant Main

Ch	Frequency [MHz]	S/A Reading AVG	Cable Loss [dB]	Atten. [dB]	Result		Power Setting
					[dBm] AVG	[mW] AVG	
58	5290	-3.63	3.97	10.03	10.37	10.89	10.5

IEEE802.11ac(80M) VHT6 Ant Aux

Ch	Frequency [MHz]	S/A Reading AVG	Cable Loss [dB]	Atten. [dB]	Result		Power Setting
					[dBm] AVG	[mW] AVG	
58	5290	-3.19	3.97	10.03	10.81	12.05	11.5

Sample Calculation:

Result = Reading + Cable Loss + Attenuator

IEEE802.11n20 HT8 Ant Main+Aux

Ch	Frequency [MHz]	Antenna	P/M Reading [dBm]	Cable Loss [dB]	Atten. [dB]	Result Total		Power Setting
						[dBm]	[dBm]	
56	5280	Main	2.04	3.98	10.03	16.05	18.77	17.0
		Aux	1.34	3.98	10.12	15.44		
60	5300	Main	2.08	3.99	10.03	16.10	18.82	17.0
		Aux	1.38	3.99	10.12	15.49		

Sample Calculation:

Result = Reading + Cable Loss + Attenuator

IEEE802.11n40 HT4 Ant Main+Aux

Ch	Frequency [MHz]	Antenna	P/M Reading [dBm]	Cable Loss [dB]	Atten. [dB]	Result Total		Power Setting
						[dBm]	[dBm]	
62	5310	Main	-2.87	3.99	10.03	11.15	13.87	13.0
		Aux	-3.56	3.99	10.12	10.55		

Sample Calculation:

Result = Reading + Cable Loss + Attenuator

IEEE802.11ac80 VHT6 Ant Main+Aux

Ch	Frequency [MHz]	Antenna	S/A Reading [dBm]	Cable Loss [dB]	Atten. [dB]	Result Total		Power Setting
						[dBm]	[dBm]	
58	5290	Main	-3.33	3.99	10.03	10.69	13.69	12.5
		Aux	-3.44	3.99	10.12	10.67		

Sample Calculation:

Result = Reading + Cable Loss + Attenuator

4) WLAN (11a/n(5500-5700MHz, 11ac(5500MHz-5720MHz)):

IEEE802.11a 6Mbps Ant Main

Ch	Frequency [MHz]	P/M Reading AVG	Cable Loss [dB]	Atten. [dB]	Result		Power Setting
					[dBm] AVG	[mW] AVG	
112	5560	2.32	4.09	10.03	16.44	44.06	16.5

IEEE802.11a 6Mbps Ant Aux

Ch	Frequency [MHz]	P/M Reading AVG	Cable Loss [dB]	Atten. [dB]	Result		Power Setting
					[dBm] AVG	[mW] AVG	
132	5660	1.99	4.14	10.03	16.16	41.30	17.0

Sample Calculation:

$$\text{Result} = \text{Reading} + \text{Cable Loss} + \text{Attenuator}$$

IEEE802.11n20 HT4 Ant Main

Ch	Frequency [MHz]	P/M Reading AVG	Cable Loss [dB]	Atten. [dB]	Result		Power Setting
					[dBm] AVG	[mW] AVG	
108	5540	1.92	4.09	10.03	16.04	40.18	17.5
120	5600	2.08	4.11	10.03	16.22	41.88	17.5
124	5620	2.13	4.12	10.03	16.28	42.46	17.5
132	5660	2.03	4.14	10.03	16.20	41.69	16.5

IEEE802.11n20 HT4 Ant Aux

Ch	Frequency [MHz]	P/M Reading AVG	Cable Loss [dB]	Atten. [dB]	Result		Power Setting
					[dBm] AVG	[mW] AVG	
116	5580	2.02	4.10	10.03	16.15	41.21	17.0

Sample Calculation:

$$\text{Result} = \text{Reading} + \text{Cable Loss} + \text{Attenuator}$$

IEEE802.11n40 HT4 Ant Main

Ch	Frequency [MHz]	P/M Reading AVG	Cable Loss [dB]	Atten. [dB]	Result		Power Setting
					[dBm] AVG	[mW] AVG	
110	5550	1.92	4.09	10.03	16.04	40.18	17.5

IEEE802.11n40 HT4 Ant Aux

Ch	Frequency [MHz]	P/M Reading AVG	Cable Loss [dB]	Atten. [dB]	Result		Power Setting
					[dBm] AVG	[mW] AVG	
102	5510	-3.72	4.08	10.03	10.39	10.94	11.0
110	5550	2.04	4.09	10.03	16.16	41.30	17.5
118	5590	1.89	4.11	10.03	16.03	40.09	17.5
134	5670	1.09	4.14	10.03	15.26	33.57	16.0

Sample Calculation:

$$\text{Result} = \text{Reading} + \text{Cable Loss} + \text{Attenuator}$$

IEEE802.11ac(20MHz) VHT0 Ant Main

Ch	Frequency [MHz]	P/M Reading AVG	Cable Loss [dB]	Atten. [dB]	Result		Power Setting
					[dBm] AVG	[mW] AVG	
144	5720	1.87	4.17	10.03	16.07	40.46	16.0

IEEE802.11ac(20MHz) VHT0 Ant Aux

Ch	Frequency [MHz]	P/M Reading AVG	Cable Loss [dB]	Atten. [dB]	Result		Power Setting
					[dBm] AVG	[mW] AVG	
144	5720	1.98	4.17	10.03	16.18	41.50	16.0

Sample Calculation:

Result = Reading + Cable Loss + Attenuator

IEEE802.11ac(40MHz) VHT0 Ant Main

Ch	Frequency [MHz]	P/M Reading AVG	Cable Loss [dB]	Atten. [dB]	Result		Power Setting
					[dBm] AVG	[mW] AVG	
142	5710	2.07	4.16	10.03	16.26	42.27	16.5

IEEE802.11ac(40MHz) VHT0 Ant Aux

Ch	Frequency [MHz]	P/M Reading AVG	Cable Loss [dB]	Atten. [dB]	Result		Power Setting
					[dBm] AVG	[mW] AVG	
142	5710	1.99	4.16	10.03	16.18	41.50	16.5

Sample Calculation:

Result = Reading + Cable Loss + Attenuator

IEEE802.11ac(80M) VHT6 Ant Main

Ch	Frequency [MHz]	S/A Reading AVG	Cable Loss [dB]	Atten. [dB]	Result		Power Setting
					[dBm] AVG	[mW] AVG	
106	5530	-5.42	4.08	10.03	8.69	7.40	9.0
122	5610	-0.50	4.12	10.03	13.65	23.17	14.5
138	5690	-0.74	4.15	10.03	13.44	22.08	14.0

IEEE802.11ac(80M) VHT6 Ant Aux

Ch	Frequency [MHz]	S/A Reading AVG	Cable Loss [dB]	Atten. [dB]	Result		Power Setting
					[dBm] AVG	[mW] AVG	
106	5530	-5.28	4.08	10.03	8.83	7.64	9.0
122	5610	-0.23	4.12	10.03	13.92	24.66	14.5
138	5690	-0.41	4.15	10.03	13.77	23.82	14.0

Sample Calculation:

Result = Reading + Cable Loss + Attenuator

IEEE802.11n20 HT8 Ant Main+Aux

Ch	Frequency [MHz]	Antenna	P/M Reading [dBm]	Cable Loss [dB]	Atten. [dB]	Result		Power Setting
						[dBm]	Total [dBm]	
108	5540	Main	1.97	4.06	10.03	16.06	19.07	18.0
		Aux	1.88	4.06	10.12	16.06		
120	5600	Main	1.93	4.1	10.03	16.06	19.33	18.0
		Aux	2.35	4.1	10.11	16.56		
124	5620	Main	2.05	4.12	10.03	16.20	19.38	18.0
		Aux	2.31	4.12	10.11	16.54		
132	5660	Main	1.98	4.14	10.03	16.15	19.22	18.0
		Aux	2.01	4.14	10.11	16.26		

Sample Calculation:

Result = Reading + Cable Loss + Attenuator

IEEE802.11n40 HT4 Ant Main+Aux

Ch	Frequency [MHz]	Antenna	P/M Reading [dBm]	Cable Loss [dB]	Atten. [dB]	Result		Power Setting
						[dBm]	Total [dBm]	
110	5550	Main	2.17	4.09	10.03	16.29	19.37	18.0
		Aux	2.22	4.09	10.12	16.43		

Sample Calculation:

Result = Reading + Cable Loss + Attenuator

IEEE802.11ac20 VHT0 Ant Main+Aux

Ch	Frequency [MHz]	Antenna	P/M Reading [dBm]	Cable Loss [dB]	Atten. [dB]	Result		Power Setting
						[dBm]	Total [dBm]	
144	5720	Main	1.98	4.16	10.03	16.17	19.10	17.5
		Aux	1.74	4.16	10.11	16.01		

Sample Calculation:

Result = Reading + Cable Loss + Attenuator

IEEE802.11ac40 VHT0 Ant Main+Aux

Ch	Frequency [MHz]	Antenna	P/M Reading [dBm]	Cable Loss [dB]	Atten. [dB]	Result		Power Setting
						[dBm]	Total [dBm]	
142	5710	Main	2.13	4.15	10.03	16.31	19.32	17.5
		Aux	2.05	4.15	10.11	16.31		

Sample Calculation:

Result = Reading + Cable Loss + Attenuator

IEEE802.11ac80 VHT6 Ant Main+Aux

Ch	Frequency [MHz]	Antenna	S/A Reading [dBm]	Cable Loss [dB]	Atten. [dB]	Result		Power Setting
						[dBm]	Total [dBm]	
122	5610	Main	-0.35	4.12	10.03	13.80	16.94	16.0
		Aux	-0.18	4.12	10.11	14.05		
138	5690	Main	-0.59	4.15	10.03	13.59	16.62	14.5
		Aux	-0.63	4.15	10.11	13.63		

Sample Calculation:

Result = Reading + Cable Loss + Attenuator

5) WLAN (11a/n/ac(5745-5825MHz)):

IEEE802.11a 6Mbps Ant Main

Ch	Frequency [MHz]	P/M Reading AVG	Cable Loss [dB]	Atten. [dB]	Result		Power Setting
					[dBm] AVG	[mW] AVG	
153	5765	2.20	4.20	10.03	16.43	43.95	16.5
157	5785	2.23	4.20	10.03	16.46	44.26	16.5
161	5805	2.20	4.21	10.03	16.44	44.06	16.5

IEEE802.11a 6Mbps Ant Aux

Ch	Frequency [MHz]	P/M Reading AVG	Cable Loss [dB]	Atten. [dB]	Result		Power Setting
					[dBm] AVG	[mW] AVG	
157	5785	2.10	4.20	10.03	16.33	42.95	16.0

Sample Calculation:

$$\text{Result} = \text{Reading} + \text{Cable Loss} + \text{Attenuator}$$

IEEE802.11n20 HT4 Ant Main

Ch	Frequency [MHz]	P/M Reading AVG	Cable Loss [dB]	Atten. [dB]	Result		Power Setting
					[dBm] AVG	[mW] AVG	
157	5785	2.15	4.20	10.03	16.38	43.45	17.0

IEEE802.11n20 HT4 Ant Aux

Ch	Frequency [MHz]	P/M Reading AVG	Cable Loss [dB]	Atten. [dB]	Result		Power Setting
					[dBm] AVG	[mW] AVG	
153	5765	2.17	4.20	10.03	16.40	43.65	17.0

Sample Calculation:

$$\text{Result} = \text{Reading} + \text{Cable Loss} + \text{Attenuator}$$

IEEE802.11n40 HT4 Ant Main

Ch	Frequency [MHz]	P/M Reading AVG	Cable Loss [dB]	Atten. [dB]	Result		Power Setting
					[dBm] AVG	[mW] AVG	
151	5755	2.09	4.20	10.03	16.32	42.85	17.0

IEEE802.11n40 HT4 Ant Aux

Ch	Frequency [MHz]	P/M Reading AVG	Cable Loss [dB]	Atten. [dB]	Result		Power Setting
					[dBm] AVG	[mW] AVG	
151	5755	1.98	4.20	10.03	16.21	41.78	17.0
159	5795	2.13	4.20	10.03	16.36	43.25	17.0

Sample Calculation:

$$\text{Result} = \text{Reading} + \text{Cable Loss} + \text{Attenuator}$$

IEEE802.11ac(80M) VHT6 Ant Main

Ch	Frequency [MHz]	S/A Reading AVG	Cable Loss [dB]	Atten. [dB]	Result		Power Setting
					[dBm] AVG	[mW] AVG	
155	5775	-0.36	4.21	10.03	13.88	24.43	14.0

IEEE802.11ac(80M) VHT6 Ant Aux

Ch	Frequency [MHz]	S/A Reading AVG	Cable Loss [dB]	Atten. [dB]	Result		Power Setting
					[dBm] AVG	[mW] AVG	
155	5775	-0.48	4.21	10.03	13.76	23.77	13.0

Sample Calculation:

$$\text{Result} = \text{Reading} + \text{Cable Loss} + \text{Attenuator}$$

IEEE802.11n20 HT8 Ant Main+Aux

Ch	Frequency [MHz]	Antenna	P/M Reading [dBm]	Cable Loss [dB]	Atten. [dB]	Result		Power Setting
						[dBm]	Total [dBm]	
153	5765	Main	2.07	4.2	10.03	16.30	19.42	17.5
		Aux	2.21	4.2	10.10	16.51	-	

Sample Calculation:

Result = Reading + Cable Loss + Attenuator

IEEE802.11n40 HT8 Ant Main+Aux

Ch	Frequency [MHz]	Antenna	P/M Reading [dBm]	Cable Loss [dB]	Atten. [dB]	Result		Power Setting
						[dBm]	Total [dBm]	
151	5755	Main	2.01	4.2	10.03	16.24	19.38	17.5
		Aux	2.20	4.2	10.10	16.50	-	

Sample Calculation:

Result = Reading + Cable Loss + Attenuator

IEEE802.11ac80 VHT6 Ant Main+Aux

Ch	Frequency [MHz]	Antenna	P/M Reading [dBm]	Cable Loss [dB]	Atten. [dB]	Result		Power Setting
						[dBm]	Total [dBm]	
155	5775	Main	-0.65	4.21	10.03	13.59	16.55	14.5
		Aux	-0.83	4.21	10.10	13.48	-	

Sample Calculation:

Result = Reading + Cable Loss + Attenuator

5.3 SAR testing operating modes

The operating mode for SAR testing was decided by the output power

1) SAR measurement for WLAN

Decision of SAR test channel

The operating mode for SAR testing was decided by the output power

The average output power for 802.11a was measured on all channels in each frequency band.

Mode	GHz	Channel	"Default Test Channel"		UNII		
			FCC 15.247				
			802.11b	802.11g			
802.11 b/g/n20	2.412	1	√	Δ			
	2.437	6	√	Δ			
	2.462	11	√	Δ			
802.11a/n20	UNII	5.18	36			√	
		5.20	40				*
		5.22	44				*
		5.24	48			√	
		5.26	52			√	
		5.28	56				*
		5.30	60				*
		5.32	64			√	
		5.50	100				*
		5.52	104			√	
		5.54	108				*
		5.56	112				*
		5.58	116			√	
		5.60	120				*
		5.62	124			√	
		5.64	128				*
	5.66	132				*	
	5.68	136			√		
	5.70	140				*	
	UNII or FCC 15.247	5.745	149	√		√	
5.765		153		*		*	
5.785		157	√			*	
5.805		161		*	√		
FCC 15.247	5.825	165	√				
802.11n40	UNII	5.19	38			√	
		5.23	46			√	
		5.27	54			√	
		5.31	62			√	
		5.51	102			√	
		5.55	110			√	
		5.59	118				*
		5.63	126			√	
	5.67	134			√		
	UNII or FCC 15.247	5.755	151	√		√	
FCC 15.247		5.795	159	√		√	

√ = "default test channels"

* = Possible 802.11a channels with maximum average output > the "default test channels"

Δ = Possible 802.11g channels with maximum average output ¼ dB ≥ the "default test channels"

SAR measurement was performed in the mode which performed SAR measurement original report
From this SAR result, measurement modes other than the original measurement mode are added.

WLAN

Mode	Test Frequency	Modulation	Crest factor	Note
IEEE802.11b	2437MHz(6ch)	DBPSK(1Mbps)	1	
IEEE802.11g	2437MHz(6ch)	BPSK(6Mbps)	1	
IEEE802.11n20 (2.4G)	2437MHz(6ch)	BPSK(HT4)	1	
IEEE802.11n40 (2.4G)	2437MHz(6ch)	BPSK(HT4)	1	
IEEE802.11a	5220MHz(44ch) 5280MHz(56ch) 5300MHz(60ch) 5320MHz(64ch) 5560MHz(112ch) 5660MHz(132ch) 5785MHz(157ch)	BPSK(6Mbps)	1	
IEEE802.11n20 (5G)	5200MHz(40ch) 5220MHz(44ch) 5240MHz(48ch) 5280MHz(56ch) 5300MHz(60ch) 5320MHz(64ch) 5540MHz(108ch) 5580MHz(116ch) 5600MHz(120ch) 5620MHz(124ch) 5660MHz(132ch) 5765MHz(153ch) 5785MHz(157ch) 5805MHz(161ch)	16QAM(HT4) BPSK(HT8)	1	
IEEE802.11n40 (5G)	5190MHz(38ch) 5230MHz(46ch) 5310MHz(62ch) 5510MHz(102ch) 5550MHz(110ch) 5590MHz(118ch) 5670MHz(134ch) 5755MHz(151ch) 5755MHz(151ch) 5795MHz(159ch)	16QAM(HT4) BPSK(HT8)	1	
IEEE802.11ac20 (5G)	5720MHz(144ch)	BPSK(VHT0)	1	
IEEE802.11ac40 (5G)	5710MHz(142ch)	BPSK(VHT0)	1	
IEEE802.11ac80 (5G)	5210MHz(42ch) 5290MHz(58ch) 5530MHz(106ch) 5610MHz(122ch) 5690MHz(138ch) 5775MHz(155ch)	64QAM(VHT6)	1	

Setting

WLAN

*Power of the EUT was set by the software as follows;

Software: DRTU Version 1.6.1-579

Power settings: See clause 5.2.

*This setting of software is the worst case.

Any conditions under the normal use do not exceed the condition of setting.

In addition, end users cannot change the settings of the output power of the product.

5.4 Confirmation after SAR testing

It was checked that the power drift [W] is within +/-5%. The verification of power drift during the SAR test is that DASY5 system calculates the power drift by measuring the E-field at the same location at beginning and the end of the scan measurement for each test position.

DASY5 system calculation Power drift value[dB] = $20\log(E_a)/(E_b)$
Before SAR testing : E_b [V/m]
After SAR testing : E_a [V/m]

Limit of power drift[W] = +/-5%
 $X[\text{dB}] = 10\log[P] = 10\log(1.05/1) = 10\log(1.05) - 10\log(1) = 0.212\text{dB}$

from E-field relations with power.

$$p = E^2/\eta = E^2/$$

Therefore, The correlation of power and the E-field

$$X[\text{dB}] = 10\log(P) = 10\log(E^2) = 20\log(E)$$

Therefore,

The calculated power drift of DASY5 System must be the less than +/-0.212dB.

SECTION 6 SAR test exclusion considerations

6.1 Standalone SAR test exclusion considerations

1) The 1-g and 10-g SAR test exclusion thresholds for 100 MHz to 6 GHz at test separation distances ≤ 50 mm are determined by:

$$[(\text{max. power of channel, including tune-up tolerance, mW}) / (\text{min. test separation distance, mm})] \cdot [\sqrt{f(\text{GHz})}] \leq 3.0$$

for 1-g SAR and ≤ 7.5 for 10-g extremity SAR, where

f(GHz) is the RF channel transmit frequency in GHz

Power and distance are rounded to the nearest mW and mm before calculation¹⁷

The result is rounded to one decimal place for comparison

The test exclusions are applicable only when the minimum test separation distance is ≤ 50 mm and for transmission frequencies between 100 MHz and 6 GHz. When the minimum test separation distance is < 5 mm, a distance of 5 mm is applied to determine SAR test exclusion.

Ant. Main WLAN 2.4GHz

Band	Standalone SAR tested	Position	Upper frequency of band *1	Maximum tune-up tolerance limit *6	Min distance *2	Calculation of exclusion *3
WLAN(2.4 GHz band)	<input checked="" type="checkbox"/>	Right side	2462 [MHz] (11ch)	16.5 [dBm] 44.67 [mW]	5 [mm]	14.0
WLAN(2.4 GHz band)	<input checked="" type="checkbox"/>	Bottom side	2462 [MHz] (11ch)	16.5 [dBm] 44.67 [mW]	20.0 [mm]	3.5
WLAN(2.4 GHz band)	<input checked="" type="checkbox"/>	Rear	2462 [MHz] (11ch)	16.5 [dBm] 44.67 [mW]	9.2 [mm]	7.6
WLAN(2.4 GHz band)	<input type="checkbox"/>	Bottom(Laptop)	2462 [MHz] (11ch)	16.5 [dBm] 44.67 [mW]	45 [mm]	1.6

Ant. Main WLAN 5GHz

Band	Standalone SAR tested	Position	Upper frequency of band *1	Maximum tune-up tolerance limit *6	Min distance *2	Calculation of exclusion *3
WLAN(5G Hz band)	<input checked="" type="checkbox"/>	Right side	5825 [MHz] (165ch)	16.5 [dBm] 44.67 [mW]	5 [mm]	21.6
WLAN(5G Hz band)	<input checked="" type="checkbox"/>	Bottom side	5825 [MHz] (165ch)	16.5 [dBm] 44.67 [mW]	20.0 [mm]	5.4
WLAN(5G Hz band)	<input checked="" type="checkbox"/>	Rear	5825 [MHz] (165ch)	16.5 [dBm] 44.67 [mW]	9.2 [mm]	11.7
WLAN(5G Hz band)	<input type="checkbox"/>	Bottom(Laptop)	5825 [MHz] (165ch)	16.5 [dBm] 44.67 [mW]	45 [mm]	2.4

Ant. Aux WLAN 2.4GHz

Band	Standalone SAR tested	Position	Upper frequency of band *1	Maximum tune-up tolerance limit *6	Min distance *2	Calculation of exclusion *3
WLAN(2.4 GHz band)	<input checked="" type="checkbox"/>	Right side	2462 [MHz] (11ch)	15.5 [dBm] 35.48 [mW]	5 [mm]	11.1
WLAN(2.4 GHz band)	<input checked="" type="checkbox"/>	Rear	2462 [MHz] (11ch)	15.5 [dBm] 35.48 [mW]	9.2 [mm]	6.1

Ant. Aux WLAN 5GHz

Band	Standalone SAR tested	Position	Upper frequency of band *1	Maximum tune-up tolerance limit *6	Min distance *2	Calculation of exclusion *3
WLAN(5G Hz band)	<input checked="" type="checkbox"/>	Right side	5825 [MHz] (165ch)	16.5 [dBm] 44.67 [mW]	5 [mm]	21.6
WLAN(5G Hz band)	<input checked="" type="checkbox"/>	Rear	5825 [MHz] (165ch)	16.5 [dBm] 44.67 [mW]	9.2 [mm]	11.7

Bluetooth

Band	Standalone SAR tested	Position	Upper frequency of band *1	Maximum tune-up tolerance limit *6	Min distance *2	Calculation of exclusion *3
Bluetooth	<input type="checkbox"/>	Right side	2480 [MHz] (79ch)	6 [dBm] 3.98 [mW]	5 [mm]	1.3
Bluetooth	<input type="checkbox"/>	Rear	2480 [MHz] (79ch)	6 [dBm] 3.98 [mW]	9.2 [mm]	0.7

2) At 100 MHz to 6 GHz and for *test separation distances* > 50 mm, the SAR test exclusion threshold is determined according to the following.

- a) [Threshold at 50 mm in step 1) + (test separation distance - 50 mm)·(f(MHz)/150)] mW, at 100 MHz to 1500 MHz
b) [Threshold at 50 mm in step 1) + (test separation distance - 50 mm)·10] mW at > 1500 MHz and ≤ 6 GHz

Ant. Main WLAN 2.4GHz

Band	Standalone SAR tested	Position	Upper frequency of band *1	Maximum tune-up tolerance limit *6	Min distance *2	Calculation of threshold*4
WLAN(2.4 GHz band)	<input type="checkbox"/>	Top side	2462 [MHz] (11ch)	16.5 [dBm] 44.67 [mW]	151 [mm]	1105.6 [mW]
WLAN(2.4 GHz band)	<input type="checkbox"/>	Top side	2462 [MHz] (11ch)	16.5 [dBm] 44.67 [mW]	151 [mm]	1105.6 [mW]

Ant. Main WLAN 5GHz

Band	Standalone SAR tested	Position	Upper frequency of band *1	Maximum tune-up tolerance limit *6	Min distance *2	Calculation of threshold*4
WLAN(5GHz band)	<input type="checkbox"/>	Top side	5825 [MHz] (165ch)	16.5 [dBm] 44.67 [mW]	151 [mm]	1072.2 [mW]

Ant. Aux WLAN 2.4GHz

Band	Standalone SAR tested	Position	Upper frequency of band *1	Maximum tune-up tolerance limit *6	Min distance *2	Calculation of threshold*4
WLAN(2.4 GHz band)	<input type="checkbox"/>	Top side	2462 [MHz] (11ch)	15.5 [dBm] 35.48 [mW]	94 [mm]	535.6 [mW]
WLAN(2.4 GHz band)	<input type="checkbox"/>	Bottom side	2462 [MHz] (11ch)	15.5 [dBm] 35.48 [mW]	77 [mm]	365.6 [mW]
WLAN(2.4 GHz band)	<input type="checkbox"/>	Bottom(Laptop)	2462 [MHz] (11ch)	15.5 [dBm] 35.48 [mW]	102 [mm]	615.6 [mW]

Ant. Aux WLAN 5GHz

Band	Standalone SAR tested	Position	Upper frequency of band *1	Maximum tune-up tolerance limit *6	Min distance *2	Calculation of threshold*4
WLAN(5G Hz band)	<input type="checkbox"/>	Top side	5825 [MHz] (165ch)	16.5 [dBm] 44.67 [mW]	94 [mm]	502.2 [mW]
WLAN(5G Hz band)	<input type="checkbox"/>	Bottom side	5825 [MHz] (165ch)	16.5 [dBm] 44.67 [mW]	77 [mm]	332.2 [mW]
WLAN(5G Hz band)	<input type="checkbox"/>	Bottom(Laptop)	5825 [MHz] (165ch)	16.5 [dBm] 44.67 [mW]	102 [mm]	582.2 [mW]

Bluetooth

Band	Standalone SAR tested	Position	Upper frequency of band *1	Maximum tune-up tolerance limit *6	Min distance *2	Calculation of threshold*4
Bluetooth	<input type="checkbox"/>	Top side	2480 [MHz] (79ch)	6 [dBm] 3.98 [mW]	94 [mm]	535.3 [mW]
Bluetooth	<input type="checkbox"/>	Bottom side	2480 [MHz] (79ch)	6 [dBm] 3.98 [mW]	77 [mm]	365.3 [mW]

*1 The upper frequency of the frequency band was used in order to calculate standalone SAR test exclusion considerations.

*2 When the minimum test separation distance is < 5 mm, a distance of 5 mm is applied to determine SAR test exclusion. Refer to Appendix 4.

*3 $[(\text{max. power of channel, including tune-up tolerance, mW})/(\text{min. test separation distance, mm})] \cdot [\sqrt{f(\text{GHz})}] \leq 3.0$
If it is Calculation of exclusion ≤ 3.0 standalone SAR test is excluded.

*4 $[(3 \cdot 50)/(\sqrt{f(\text{GHz})})] + (\text{test separation distance} - 50 \text{ mm}) \cdot 10 \text{ mW}$ at > 1500 MHz and $\leq 6 \text{ GHz}$
If it is maximum tune-up tolerance limit < Threshold, standalone SAR test is excluded.

*5 Please refer to an attached sheet(tune-up procedure).

*6 The measured output power is the maximum tune-up tolerance limit on specification.

*7 Maximum tune-up tolerance limit is maximum power of test report of Bluetooth module (FCC ID: QDS-BRCM1073 Test report No.: FR330410AC).

SECTION 7 : Description of the Body setup

7.1 Description of the Body setup

i) Procedure for SAR testing

-The tested procedure was performed according to the KDB 447498 D01 (Mobile and Portable Device RF Exposure Procedures and Equipment Authorization Policies) and the KDB 616217 D04.

ii) Test mode

WLAN	Data transmission mode (11a/b/g/n/ac)
------	---------------------------------------

iii) Test position

No.	Position*1	Test distance	WLAN(Main ant)		WLAN(Aux ant)	
			Tested	Antenna	Tested	Antenna
1	Top side (Tablet)	0mm	<input type="checkbox"/>	Fixed	<input type="checkbox"/>	Fixed
2	Right side (Tablet)	0mm	<input checked="" type="checkbox"/>	Fixed	<input checked="" type="checkbox"/>	Fixed
3	Bottom side (Tablet)	0mm	<input checked="" type="checkbox"/>	Fixed	<input type="checkbox"/>	Fixed
4	Rear (Tablet)	0mm	<input checked="" type="checkbox"/>	Fixed	<input checked="" type="checkbox"/>	Fixed
5	Bottom (Laptop)	0mm	<input type="checkbox"/>	Fixed	<input type="checkbox"/>	Fixed

*1 Refer to Section 6 and Appendix 4.

<Antenna position>

The antennas use for WLAN Main and WLAN Aux(Shared Bluetooth) are both separate in a single fixed position. The antennas are integral part of the device. Refer to Appendix

A

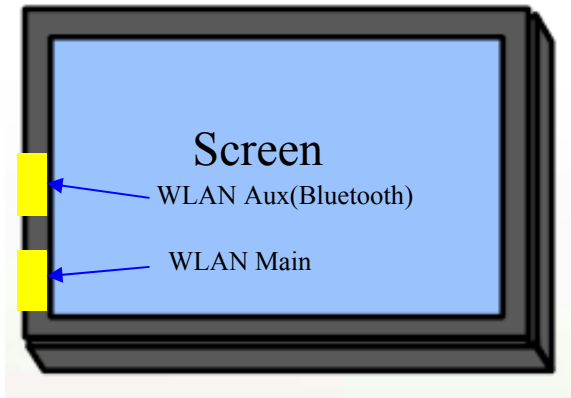

Tablet style

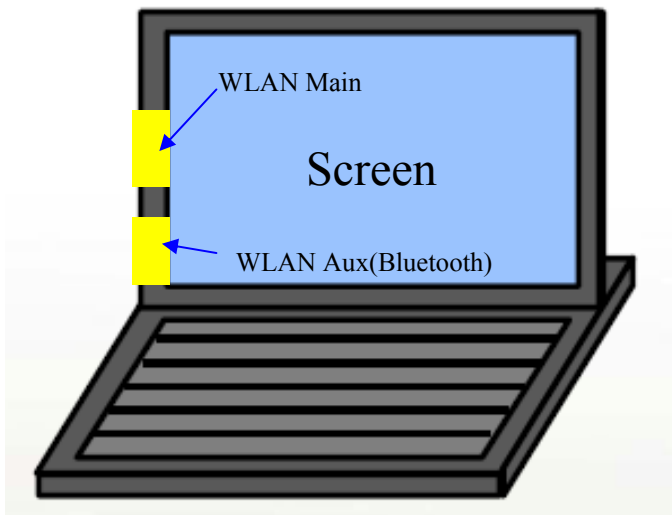

Laptop style

SECTION 8 : Test surrounding

8.1 Measurement uncertainty

The uncertainty budget has been determined for the DASY5 measurement system according to the SPEAG documents[2] and is given in the following Table.

<0.3 – 3GHz range>

Error Description	Uncertain value ±	Probability distribution	divisor	(ci) lg	Standard (lg)	vi or v _{eff}
Measurement System						
Probe calibration	± 6.00	Normal	1	1	± 6.00	∞
Axial isotropy of the probe	± 4.7	Rectangular	√3	0.7	± 1.9	∞
Spherical isotropy of the probe	± 9.6	Rectangular	√3	0.7	± 3.9	∞
Boundary effects	± 1.0	Rectangular	√3	1	± 0.6	∞
Probe linearity	± 4.7	Rectangular	√3	1	± 2.7	∞
Detection limit	± 1.0	Rectangular	√3	1	± 0.6	∞
Modulation response	± 2.4	Rectangular	√3	1	± 1.4	∞
Readout electronics	± 0.3	Normal	1	1	± 0.3	∞
Response time	± 0.8	Rectangular	√3	1	± 0.5	∞
Integration time	± 2.6	Rectangular	√3	1	± 1.5	∞
RF ambient Noise	± 3.0	Rectangular	√3	1	± 1.7	∞
RF ambient Reflections	± 3.0	Rectangular	√3	1	± 1.7	∞
Probe Positioner	± 0.4	Rectangular	√3	1	± 0.2	∞
Probe positioning	± 2.9	Rectangular	√3	1	± 1.7	∞
Max.SAR Eval.	± 1.0	Rectangular	√3	1	± 0.6	∞
Test Sample Related						
Device positioning	± 2.9	Normal	1	1	± 2.9	12
Device holder uncertainty	± 3.6	Normal	1	1	± 3.6	2
Power drift	± 5.0	Rectangular	√3	1	± 2.9	∞
Power Scaling	+ 0.0	Rectangular	√3	1	± 0.0	∞
Phantom and Setup						
Phantom uncertainty	± 4.0	Rectangular	√3	1	± 2.3	∞
Liquid conductivity (target)	± 5.0	Rectangular	√3	0.64	± 1.8	∞
Liquid conductivity (meas.)	+ 2.9	Rectangular	1	0.64	+ 1.9	∞
Liquid permittivity (target)	± 5.0	Rectangular	√3	0.6	± 1.7	∞
Liquid permittivity (meas.)	- 3.7	Rectangular	1	0.6	- 2.2	∞
Liquid conductivity - temp.unc (below 2deg.C.)	± 1.7	Rectangular	√3	0.78	± 0.8	∞
Liquid permittivity - temp.unc (below 2deg.C.)	± 0.3	Rectangular	√3	0.23	± 0.0	∞
Combined Standard Uncertainty					± 11.180	
Expanded Uncertainty (k=2)					± 22.4	

<3 – 6GHz range>

Error Description	Uncertain value \pm	Probability distribution	divisor	(ci) lg	Standard (lg)	vi or veff
Measurement System						
Probe calibration	\pm 6.55	Normal	1	1	\pm 6.55	∞
Axial isotropy of the probe	\pm 4.7	Rectangular	$\sqrt{3}$	0.7	\pm 1.9	∞
Spherical isotropy of the probe	\pm 9.6	Rectangular	$\sqrt{3}$	0.7	\pm 3.9	∞
Boundary effects	\pm 2.0	Rectangular	$\sqrt{3}$	1	\pm 1.2	∞
Probe linearity	\pm 4.7	Rectangular	$\sqrt{3}$	1	\pm 2.7	∞
Detection limit	\pm 1.0	Rectangular	$\sqrt{3}$	1	\pm 0.6	∞
Modulation response	\pm 2.4	Rectangular	$\sqrt{3}$	1	\pm 1.4	∞
Readout electronics	\pm 0.3	Normal	1	1	\pm 0.3	∞
Response time	\pm 0.8	Rectangular	$\sqrt{3}$	1	\pm 0.5	∞
Integration time	\pm 2.6	Rectangular	$\sqrt{3}$	1	\pm 1.5	∞
RF ambient Noise	\pm 3.0	Rectangular	$\sqrt{3}$	1	\pm 1.7	∞
RF ambient Reflections	\pm 3.0	Rectangular	$\sqrt{3}$	1	\pm 1.7	∞
Probe Positioner	\pm 0.8	Rectangular	$\sqrt{3}$	1	\pm 0.5	∞
Probe positioning	\pm 6.7	Rectangular	$\sqrt{3}$	1	\pm 3.9	∞
Max.SAR Eval.	\pm 4.0	Rectangular	$\sqrt{3}$	1	\pm 2.3	∞
Test Sample Related						
Device positioning	\pm 2.9	Normal	1	1	\pm 2.9	87
Device holder uncertainty	\pm 3.6	Normal	1	1	\pm 3.6	2
Power drift	\pm 5.0	Rectangular	$\sqrt{3}$	1	\pm 2.9	∞
Power Scaling	+ 0.0	Rectangular	$\sqrt{3}$	1	\pm 0.0	∞
Phantom and Setup						
Phantom uncertainty	\pm 4.0	Rectangular	$\sqrt{3}$	1	\pm 2.3	∞
Liquid conductivity (target)	\pm 5.0	Rectangular	$\sqrt{3}$	0.64	\pm 1.8	∞
Liquid conductivity (meas.)	+ 4.5	Rectangular	1	0.64	+ 2.9	∞
Liquid permittivity (target)	\pm 5.0	Rectangular	$\sqrt{3}$	0.6	\pm 1.7	∞
Liquid permittivity (meas.)	- 4.4	Rectangular	1	0.6	- 2.6	∞
Liquid conductivity - temp.unc (below 2deg.C.)	\pm 1.7	Rectangular	$\sqrt{3}$	0.78	\pm 0.8	∞
Liquid permittivity - temp.unc (below 2deg.C.)	\pm 0.3	Rectangular	$\sqrt{3}$	0.23	\pm 0.0	∞
Combined Standard Uncertainty					\pm 12.536	
Expanded Uncertainty (k=2)					\pm 25.1	

SECTION 9 : Measurement results

9.1 WLAN Body SAR (2.4G)

(1)Method of measurement

- Step.1 The searching for the worst position
The test was performed in mode of the maximum average output power
- Step.2 The searching for the worst transmitter mode.
The other mode was performed at the worst position of Step.1.
- Step.3 11n MIMO mode
The 11n MIMO mode was performed at the worst position of Step.1.

Note:

- 1)The other channel was not required since maximum average output power channel SAR value(1g average) is < 0.80 W/kg.
- 2)The other channel was not required since peak SAR value is < 1.6 W/kg. Only the Maximum peak SAR mode is measured.
- 3)Repeated measurement is not required when the original highest measured SAR is < 0.80 W/kg.

(2)Simulated Tissue Liquid Parameter confirmation

The dielectric parameters were checked prior to assessment using the HP85070D dielectric probe kit.
The dielectric parameters measurement is reported in each correspondent section.

DIELECTRIC PARAMETERS MEASUREMENT RESULTS										
Date	Ambient Temp. [deg.c]	Relative Humidity [%]	Liquid type	Liquid Temp. [deg.c]	Measured Frequency [MHz]	Parameters	Target Value*1	Measured	Deviation [%]	Limit [%]
29-May	24.5	55	MSL 2450	24.0	2450	ϵ_r	52.7	50.8	-3.7	+/-5
						σ [mho/m]	1.95	2.01	2.9	+/-5

ϵ_r : Relative Permittivity / σ : Coconductivity

*1 The Target value is a parameter defined in FCC OET65.

(3)Result of Body SAR

BODY SAR MEASUREMENT RESULTS													
Frequency		Modulation	Max power(Meas)		Maximum tune-up tolerance limit		Phantom Section	EUT Set-up Conditions			Measured SAR(1g) [W/kg]	Reported SAR(1g) *1 [W/kg]	
Channel	[MHz]		[dBm]	[mW]	[dBm]	[mW]		Antenna	Position	Separation [mm]	Maximum of multi-peak	Maximum of multi-peak	
Step.1 Position searching													
6	2437	11g 6Mbps	16.16	41.30	16.50	44.67	Flat	Main	Right side (Tablet)	0	0.493	0.533	
6	2437	11g 6Mbps	16.16	41.30	16.50	44.67	Flat	Main	Bottom side (Tablet)	0	0.027	0.029	
6	2437	11g 6Mbps	16.16	41.30	16.50	44.67	Flat	Main	Rear (Tablet)	0	0.160	0.173	
Step.2 Mode change													
6	2437	11b 1Mbps	15.18	32.96	15.50	35.48	Flat	Main	Right side (Tablet)	0	0.410	0.441	
6	2437	11n20 HT4	16.16	41.30	16.50	44.67	Flat	Main	Right side (Tablet)	0	0.534	0.577	
6	2437	11n40 HT4	16.24	42.07	16.47	44.36	Flat	Main	Right side (Tablet)	0	0.608	0.641	

*1 Reported SAR= Maximum tune-up tolerance limit [mW] / Measured maximum power [mW] · Measured SAR [W/kg]

BODY SAR MEASUREMENT RESULTS													
Frequency		Modulation	Max power(Meas)		Maximum tune-up tolerance limit		Phantom Section	EUT Set-up Conditions			Measured SAR(1g) [W/kg]	Reported SAR(1g) *1 [W/kg]	
Channel	[MHz]		[dBm]	[mW]	[dBm]	[mW]		Antenna	Position	Separation [mm]	Maximum of multi-peak	Maximum of multi-peak	
Step.1 Position searching													
6	2437	11g 6Mbps	15.19	33.04	15.49	35.40	Flat	Aux	Right side (Tablet)	0	0.271	0.290	
6	2437	11g 6Mbps	15.19	33.04	15.49	35.40	Flat	Aux	Rear (Tablet)	0	0.209	0.224	
Step.2 Mode change													
6	2437	11b 1Mbps	13.55	22.65	14.00	25.12	Flat	Aux	Right side (Tablet)	0	0.134	0.149	
6	2437	11n20 HT4	15.06	32.06	15.50	35.48	Flat	Aux	Right side (Tablet)	0	0.267	0.295	
6	2437	11n40 HT4	13.37	21.73	13.42	21.98	Flat	Aux	Right side (Tablet)	0	0.181	0.183	

*1 Reported SAR= Maximum tune-up tolerance limit [mW] / Measured maximum power [mW] · Measured SAR [W/kg]

BODY SAR MEASUREMENT RESULTS													
Frequency		Modulation	Max power(Meas)		Maximum tune-up tolerance limit		Phantom Section	EUT Set-up Conditions			Measured SAR(1g) [W/kg]	Reported SAR(1g) *1 [W/kg]	
Channel	[MHz]		[dBm]	[mW]	[dBm]	[mW]		Antenna	Position	Separation [mm]	Maximum of multi-peak	Maximum of multi-peak	
Step.3 11n MIMO mode													
6	2437	11n 20 HT8	18.9	77.62	19.04	80.17	Flat	Main + Aux	Right side (Tablet)	0	0.519	0.536	
6	2437	11n 40 HT8	17.99	62.95	18.22	66.37	Flat	Main + Aux	Right side (Tablet)	0	0.532	0.561	

*1 Reported SAR= Maximum tune-up tolerance limit [mW] / Measured maximum power [mW] · Measured SAR [W/kg]

9.2 WLAN Body SAR (5G)

(1)Method of measurement

5.2GHz band

- Step.1 The searching for the worst position
The test was performed in mode of the maximum average output power
- Step.2 The searching for the worst transmitter mode.
The other mode was performed at the worst position of Step.1.
- Step.3 The changing to the channels
The test was performed at the worst condition of Step1 to Step2.
- Step.4 11n MIMO mode measured
The other mode was performed at the worst position of Step.1.

5.3GHz band

- Step.1 The searching for the worst position
The test was performed in mode of the maximum average output power
- Step.2 The searching for the worst transmitter mode.
The other mode was performed at the worst position of Step.1.
- Step.3 The changing to the channels
The test was performed at the worst condition of Step1 to Step2.
- Step.4 The searching for the worst position (11n MIMO mode)
The other mode was performed at the worst position of Step.1(Worst position of Main ant and Aux ant).
- Step.5 11n MIMO mode measured
The other mode was performed at the worst position of Step.1.

5.6GHz band

- Step.1 The searching for the worst position
The test was performed in mode of the maximum average output power
- Step.2 The searching for the worst transmitter mode.
The other mode was performed at the worst position of Step.1.
- Step.3 The changing to the channels
The test was performed at the worst condition of Step1 to Step2.
- Step.4 The searching for the worst position (11n MIMO mode)
The other mode was performed at the worst position of Step.1(Worst position of Main ant and Aux ant).
- Step.5 11n MIMO mode measured
The other mode was performed at the worst position of Step.1.
- Step.6 The changing to the channels(11n MIMO mode)
The test was performed at the worst condition of Step1 to Step2.

5.8GHz band

- Step.1 The searching for the worst position
The test was performed in mode of the maximum average output power
- Step.2 The searching for the worst transmitter mode.
The other mode was performed at the worst position of Step.1.
- Step.3 The changing to the channels
The test was performed at the worst condition of Step1 to Step2.
- Step.4 11n MIMO mode measured
The other mode was performed at the worst position of Step.1.

Note:

- 1)For 5500-5700MHz band, the other channel was not required since maximum average output power channel SAR value(1g average) is < 0.40 W/kg.
- 2) For 5180-5240MHz band, 5260-5320MHz and 5745-5825MHz band, the other channel was not required since maximum average output power channel SAR value(1g average) is < 0.80 W/kg.
- 3)The other channel was not required since peak SAR value is < 1.6 W/kg. Only the Maximum peak SAR mode is measured..
- 4) Repeated measurement is not required when the original highest measured SAR is < 0.80 W/kg.

(2) Simulated Tissue Liquid Parameter confirmation

The dielectric parameters were checked prior to assessment using the HP85070D dielectric probe kit.
The dielectric parameters measurement is reported in each correspondent section.

DIELECTRIC PARAMETERS MEASUREMENT RESULTS										
Date	Ambient Temp. [deg.c]	Relative Humidity [%]	Liquid type	Liquid Temp. [deg.c]	Measured Frequency [MHz]	Parameters	Target Value*1	Measured	Deviation [%]	Limit [%]
3-Jun	24.5	59	MSL 3-6GHz	24.0	5200	ϵ_r	49.0	48.0	-2.1	+/-5
						σ [mho/m]	5.30	5.46	3.1	+/-5
4-Jun	24.5	57	MSL 3-6GHz	24.0	5200	ϵ_r	49.0	48.7	-0.6	+/-5
						σ [mho/m]	5.30	5.47	3.3	+/-5
5-Jun	24.5	48	MSL 3-6GHz	24.0	5300	ϵ_r	48.9	48.5	-0.9	+/-5
						σ [mho/m]	5.42	5.60	3.3	+/-5
10-Jun	24	49	MSL 3-6GHz	23.5	5600	ϵ_r	48.5	46.4	-4.4	+/-5
						σ [mho/m]	5.77	5.66	-1.9	+/-5
11-Jun	24	55	MSL 3-6GHz	23.5	5600	ϵ_r	48.5	46.5	-4.2	+/-5
						σ [mho/m]	5.77	5.70	-1.2	+/-5
12-Jun	24	56	MSL 3-6GHz	23.5	5800	ϵ_r	48.2	47.9	-0.7	+/-5
						σ [mho/m]	6.00	6.25	4.2	+/-5
13-Jun	24	61	MSL 3-6GHz	23.5	5800	ϵ_r	48.2	47.9	-0.7	+/-5
						σ [mho/m]	6.00	6.27	4.5	+/-5

ϵ_r : Relative Permittivity / σ : Conductivity

*1 The Target value is a parameter defined in FCC OET65.

(3)Result of Body SAR
5.2GHz band

BODY SAR MEASUREMENT RESULTS												
Frequency		Modulation	Max power(Meas)		Maximum tune-up tolerance limit		Phantom Section	EUT Set-up Conditions			Measured SAR(1g) [W/kg]	Reported SAR(1g) *1 [W/kg]
Channel	[MHz]		[dBm]	[mW]	[dBm]	[mW]		Antenna	Position	Separation [mm]	Maximum of multi-peak	Maximum of multi-peak
Step.1 Position searching												
44	5220	11a 6Mbps	15.90	38.90	16.00	39.81	Flat	Main	Right side (Tablet)	0	0.450	0.460
44	5220	11a 6Mbps	15.90	38.90	16.00	39.81	Flat	Main	Bottom side (Tablet)	0	0.038	0.039
44	5220	11a 6Mbps	15.90	38.90	16.00	39.81	Flat	Main	Rear (Tablet)	0	0.123	0.126
Step.2 Mode change												
44	5220	11n20 HT4	15.51	35.56	16.00	39.81	Flat	Main	Right side (Tablet)	0	0.595	0.666
46	5230	11n40 HT4	15.11	32.43	15.42	34.83	Flat	Main	Right side (Tablet)	0	0.565	0.607
42	5210	11ac80 VHT	8.02	6.34	8.46	7.01	Flat	Main	Right side (Tablet)	0	0.090	0.100
Step.3 Channel change (Max peak SAR in Step.1 and Step.2 > 1.6 w/kg)												
40	5200	11n20 HT4	15.49	35.40	15.87	38.64	Flat	Main	Right side (Tablet)	0	0.425	0.464
48	5240	11n20 HT4	15.42	34.83	15.48	35.32	Flat	Main	Right side (Tablet)	0	0.507	0.514

*1 Reported SAR= Maximum tune-up tolerance limit [mW] / Measured maximum power [mW] · Measured SAR [W/kg]

BODY SAR MEASUREMENT RESULTS												
Frequency		Modulation	Max power(Meas)		Maximum tune-up tolerance limit		Phantom Section	EUT Set-up Conditions			Measured SAR(1g) [W/kg]	Reported SAR(1g) *1 [W/kg]
Channel	[MHz]		[dBm]	[mW]	[dBm]	[mW]		Antenna	Position	Separation [mm]	Maximum of multi-peak	Maximum of multi-peak
Step.1 Position searching												
44	5220	11a 6Mbps	15.71	37.24	16.00	39.81	Flat	Aux	Right side (Tablet)	0	0.464	0.496
44	5220	11a 6Mbps	15.71	37.24	16.00	39.81	Flat	Aux	Rear (Tablet)	0	0.365	0.390
Step.2 Mode change												
44	5220	11n20 HT4	15.58	36.14	16.00	39.81	Flat	Aux	Right side (Tablet)	0	0.424	0.467
46	5230	11n40 HT4	14.97	31.41	15.37	34.43	Flat	Aux	Right side (Tablet)	0	0.487	0.534
42	5210	11ac80 VHT	8.17	6.56	8.39	6.90	Flat	Aux	Right side (Tablet)	0	0.059	0.062
Step.3 Channel change (Max peak SAR in Step.1 and Step.2 > 1.6 w/kg)												
38	5190	11n40 HT4	9.91	9.79	9.94	9.86	Flat	Aux	Right side (Tablet)	0	0.114	0.115

*1 Reported SAR= Maximum tune-up tolerance limit [mW] / Measured maximum power [mW] · Measured SAR [W/kg]

BODY SAR MEASUREMENT RESULTS												
Frequency		Modulation	Max power(Meas)		Maximum tune-up tolerance limit		Phantom Section	EUT Set-up Conditions			Measured SAR(1g) [W/kg]	Reported SAR(1g) *1 [W/kg]
Channel	[MHz]		[dBm]	[mW]	[dBm]	[mW]		Antenna	Position	Separation [mm]	Maximum of multi-peak	Maximum of multi-peak
Step.4 11n MIMO mode												
44	5220	11n20 HT8	18.81	76.03	19.01	79.62	Flat	Main+Aux	Right side (Tablet)	0	0.300	0.314
46	5230	11n40 HT8	18.33	68.08	18.41	69.34	Flat	Main+Aux	Right side (Tablet)	0	0.268	0.273
42	5210	11ac80 VHT	11.34	13.61	11.44	13.93	Flat	Main+Aux	Right side (Tablet)	0	0.050	0.051

*1 Reported SAR= Maximum tune-up tolerance limit [mW] / Measured maximum power [mW] · Measured SAR [W/kg]

5.3GHz band

BODY SAR MEASUREMENT RESULTS												
Frequency		Modulation	Max power(Meas)		Maximum tune-up tolerance limit		Phantom Section	EUT Set-up Conditions			Measured SAR(1g) [W/kg]	Reported SAR(1g) *1 [W/kg]
Channel	[MHz]		[dBm]	[mW]	[dBm]	[mW]		Antenna	Position	Separation [mm]	Maximum of multi-peak	Maximum of multi-peak
Step.1 Position searching												
60	5300	11a 6Mbps	15.68	36.98	16.00	39.81	Flat	Main	Right side (Tablet)	0	0.331	0.356
60	5300	11a 6Mbps	15.68	36.98	16.00	39.81	Flat	Main	Bottom side (Tablet)	0	0.000085	0.0000915
60	5300	11a 6Mbps	15.68	36.98	16.00	39.81	Flat	Main	Rear (Tablet)	0	0.122	0.131
Step.2 Mode change												
60	5300	11n20 HT4	15.88	38.73	15.94	39.26	Flat	Main	Right side (Tablet)	0	0.462	0.468
62	5310	11n40 HT4	10.77	11.94	11.00	12.59	Flat	Main	Right side (Tablet)	0	0.145	0.153
58	5290	11ac80 VHT	10.37	10.89	10.47	11.14	Flat	Main	Right side (Tablet)	0	0.131	0.134
Step.3 Channel change (Max peak SAR in Step.1 and Step.2 > 1.6 w/kg)												
56	5280	11n20 HT4	15.83	38.28	15.87	38.64	Flat	Main	Right side (Tablet)	0	0.472	0.476
64	5320	11n20 HT4	13.13	20.56	13.46	22.18	Flat	Main	Right side (Tablet)	0	0.320	0.345

*1 Reported SAR= Maximum tune-up tolerance limit [mW] / Measured maximum power [mW] · Measured SAR [W/kg]

BODY SAR MEASUREMENT RESULTS												
Frequency		Modulation	Max power(Meas)		Maximum tune-up tolerance limit		Phantom Section	EUT Set-up Conditions			Measured SAR(1g) [W/kg]	Reported SAR(1g) *1 [W/kg]
Channel	[MHz]		[dBm]	[mW]	[dBm]	[mW]		Antenna	Position	Separation [mm]	Maximum of multi-peak	Maximum of multi-peak
Step.1 Position searching												
60	5300	11a 6Mbps	15.95	39.36	16.00	39.81	Flat	Aux	Right side (Tablet)	0	0.417	0.422
60	5300	11a 6Mbps	15.95	39.36	16.00	39.81	Flat	Aux	Rear (Tablet)	0	0.449	0.454
Step.2 Mode change												
56	5280	11n20 HT4	15.62	36.48	15.93	39.17	Flat	Aux	Rear (Tablet)	0	0.433	0.465
62	5310	11n40 HT4	10.67	11.67	10.97	12.50	Flat	Aux	Rear (Tablet)	0	0.124	0.133
58	5290	11ac80 VHT	10.81	12.05	10.92	12.36	Flat	Aux	Rear (Tablet)	0	0.120	0.123
Step.3 Channel change (Max peak SAR in Step.1 and Step.2 > 1.6 w/kg)												
56	5280	11a 6Mbps	15.9	38.90	15.93	39.17	Flat	Aux	Rear (Tablet)	0	0.466	0.469
64	5320	11a 6Mbps	12.72	18.71	12.94	19.68	Flat	Aux	Rear (Tablet)	0	0.171	0.180

*1 Reported SAR= Maximum tune-up tolerance limit [mW] / Measured maximum power [mW] · Measured SAR [W/kg]

BODY SAR MEASUREMENT RESULTS												
Frequency		Modulation	Max power(Meas)		Maximum tune-up tolerance limit		Phantom Section	EUT Set-up Conditions			Measured SAR(1g)	Reported SAR(1g) *1
Channel	[MHz]		[dBm]	[mW]	[dBm]	[mW]		Antenna	Position	Separation [mm]	Maximum of multi-peak	Maximum of multi-peak
Step.4 Position searching												
56	5280	11n20 HT8	18.77	75.34	18.88	77.27	Flat	Main+Aux	Right side (Tablet)	0	0.576	0.591
56	5280	11n20 HT8	18.77	75.34	18.88	77.27	Flat	Main+Aux	Rear (Tablet)	0	0.229	0.235
Step.5 11n MIMO mode												
62	5310	11n40 HT8	13.87	24.38	14.00	25.12	Flat	Main+Aux	Right side (Tablet)	0	0.124	0.128
58	5290	11ac80 VHT	13.69	23.39	13.71	23.50	Flat	Main+Aux	Right side (Tablet)	0	0.171	0.172
Step.6 Channel change (Max SAR(1g) in Step.4 > 0.8 w/kg or Max peak SAR in Step.4 > 1.6 w/kg)												
60	5300	11n20 HT8	18.82	76.21	18.91	77.80	Flat	Main+Aux	Right side (Tablet)	0	0.288	0.294

*1 Reported SAR= Maximum tune-up tolerance limit [mW] / Measured maximum power [mW] · Measured SAR [W/kg]

5.6GHz band

BODY SAR MEASUREMENT RESULTS												
Frequency		Modulation	Max power(Meas)		Maximum tune-up tolerance limit		Phantom Section	EUT Set-up Conditions			Measured SAR(1g) [W/kg]	Reported SAR(1g) *1 [W/kg]
Channel	[MHz]		[dBm]	[mW]	[dBm]	[mW]		Antenna	Position	Separation [mm]	Maximum of multi-peak	Maximum of multi-peak
Step.1 Position searching												
112	5560	11a 6Mbps	16.44	44.06	16.50	44.67	Flat	Main	Right side (Tablet)	0	0.214	0.217
112	5560	11a 6Mbps	16.44	44.06	16.50	44.67	Flat	Main	Bottom side (Tablet)	0	0.049	0.050
112	5560	11a 6Mbps	16.44	44.06	16.50	44.67	Flat	Main	Rear (Tablet)	0	0.326	0.331
Step.2 Mode change (Rear position)												
124	5620	11n20 HT4	16.28	42.46	16.50	44.67	Flat	Main	Rear (Tablet)	0	0.433	0.455
110	5550	11n40 HT4	16.04	40.18	16.48	44.46	Flat	Main	Rear (Tablet)	0	0.315	0.349
144	5720	11ac20 VHT	16.07	40.46	16.48	44.46	Flat	Main	Rear (Tablet)	0	0.405	0.445
142	5710	11ac40 VHT	16.26	42.27	16.43	43.95	Flat	Main	Rear (Tablet)	0	0.432	0.449
122	5610	11ac80 VHT	13.66	23.23	13.95	24.83	Flat	Main	Rear (Tablet)	0	0.160	0.171
138	5690	11ac80 VHT	13.44	22.08	13.92	24.66	Flat	Main	Rear (Tablet)	0	0.208	0.232
Step.3 Channel change (Max SAR(1g) in Step.1 and Step.2 > 0.4 w/kg and Max peak SAR in Step.1 and Step.2 > 1.6 w/kg)												
108	5540	11n20 HT4	16.04	40.18	16.48	44.46	Flat	Main	Rear (Tablet)	0	0.198	0.219
120	5600	11n20 HT4	16.22	41.88	16.48	44.46	Flat	Main	Rear (Tablet)	0	0.344	0.365
132	5660	11n20 HT4	16.2	41.69	16.45	44.16	Flat	Main	Rear (Tablet)	0	0.415	0.440

*1 Reported SAR= Maximum tune-up tolerance limit [mW] / Measured maximum power [mW] · Measured SAR [W/kg]

BODY SAR MEASUREMENT RESULTS												
Frequency		Modulation	Max power(Meas)		Maximum tune-up tolerance limit		Phantom Section	EUT Set-up Conditions			Measured SAR(1g) [W/kg]	Reported SAR(1g) *1 [W/kg]
Channel	[MHz]		[dBm]	[mW]	[dBm]	[mW]		Antenna	Position	Separation [mm]	Maximum of multi-peak	Maximum of multi-peak
Step.1 Position searching												
132	5660	11a 6Mbps	16.16	41.30	16.50	44.67	Flat	Aux	Right side (Tablet)	0	0.357	0.386
132	5660	11a 6Mbps	16.16	41.30	16.50	44.67	Flat	Aux	Rear (Tablet)	0	0.287	0.310
Step.2 Mode change(Right position)												
116	5580	11n20 HT4	16.15	41.21	16.50	44.67	Flat	Aux	Right side (Tablet)	0	0.355	0.385
110	5550	11n40 HT4	16.16	41.30	16.48	44.46	Flat	Aux	Right side (Tablet)	0	0.485	0.522
144	5720	11ac20 VHT	16.18	41.50	16.42	43.85	Flat	Aux	Right side (Tablet)	0	0.377	0.398
142	5710	11ac40 VHT	16.18	41.50	16.47	44.36	Flat	Aux	Right side (Tablet)	0	0.346	0.370
122	5610	11ac80 VHT	13.91	24.60	13.97	24.95	Flat	Aux	Right side (Tablet)	0	0.274	0.278
138	5690	11ac80 VHT	13.77	23.82	13.99	25.06	Flat	Aux	Right side (Tablet)	0	0.230	0.242
Step.3 Channel change (Max SAR(1g) in Step.1 and Step.2 > 0.4 w/kg and Max peak SAR in Step.1 and Step.2 > 1.6 w/kg)												
102	5510	11n40 HT4	10.39	10.94	10.48	11.17	Flat	Aux	Right side (Tablet)	0	0.090	0.092
118	5590	11n40 HT4	16.03	40.09	16.43	43.95	Flat	Aux	Right side (Tablet)	0	0.510	0.559
134	5670	11n40 HT4	15.26	33.57	15.46	35.16	Flat	Aux	Right side (Tablet)	0	0.371	0.388
106	5530	11ac80 VHT	8.83	7.64	8.91	7.78	Flat	Aux	Right side (Tablet)	0	0.070	0.071

*1 Reported SAR= Maximum tune-up tolerance limit [mW] / Measured maximum power [mW] · Measured SAR [W/kg]

BODY SAR MEASUREMENT RESULTS												
Frequency		Modulation	Max power(Meas)		Maximum tune-up tolerance limit		Phantom Section	EUT Set-up Conditions			Measured SAR(1g) [W/kg]	Reported SAR(1g) *1 [W/kg]
Channel	[MHz]		[dBm]	[mW]	[dBm]	[mW]		Antenna	Position	Separation [mm]	Maximum of multi-peak	Maximum of multi-peak
Step.4 Position searching												
124	5620	11n20 HT8	19.38	86.70	19.5	89.13	Flat	Main+Aux	Rear side (Tablet)	0	0.261	0.268
124	5620	11n20 HT8	19.38	86.70	19.5	89.13	Flat	Main+Aux	Right side (Tablet)	0	0.278	0.286
Step.5 11n MIMO mode												
110	5550	11n40 HT8	19.37	86.50	19.49	88.92	Flat	Main+Aux	Right side (Tablet)	0	0.249	0.256
144	5720	11ac20 VHT	19.1	81.28	19.46	88.31	Flat	Main+Aux	Right side (Tablet)	0	0.270	0.293
142	5710	11ac40 VHT	19.32	85.51	19.46	88.31	Flat	Main+Aux	Right side (Tablet)	0	0.229	0.237
122	5610	11ac80 VHT	16.94	49.43	16.97	49.77	Flat	Main+Aux	Right side (Tablet)	0	0.176	0.177
138	5690	11ac80 VHT	16.62	45.92	16.97	49.77	Flat	Main+Aux	Right side (Tablet)	0	0.229	0.248
Step.6 Channel change (Max peak SAR in Step.4 and Step.5 > 1.6 w/kg)												
108	5540	11n20 HT8	19.07	80.72	19.45	88.10	Flat	Main+Aux	Right side (Tablet)	0	0.309	0.337
120	5600	11n20 HT8	19.33	85.70	19.46	88.31	Flat	Main+Aux	Right side (Tablet)	0	0.287	0.296
132	5660	11n20 HT8	19.22	83.56	19.47	88.51	Flat	Main+Aux	Right side (Tablet)	0	0.308	0.326

*1 Reported SAR= Maximum tune-up tolerance limit [mW] / Measured maximum power [mW] · Measured SAR [W/kg]

5.8GHz band

BODY SAR MEASUREMENT RESULTS												
Frequency		Modulation	Max power(Meas)		Maximum tune-up tolerance limit		Phantom Section	EUT Set-up Conditions			Measured SAR(1g) [W/kg]	Reported SAR(1g) *1 [W/kg]
Channel	[MHz]		[dBm]	[mW]	[dBm]	[mW]		Antenna	Position	Separation [mm]	Maximum of multi-peak	Maximum of multi-peak
Step.1 Position searching												
157	5785	11a 6Mbps	16.46	44.26	16.50	44.67	Flat	Main	Right side (Tablet)	0	0.381	0.385
157	5785	11a 6Mbps	16.46	44.26	16.50	44.67	Flat	Main	Bottom side (Tablet)	0	0.068	0.069
157	5785	11a 6Mbps	16.46	44.26	16.50	44.67	Flat	Main	Rear (Tablet)	0	0.576	0.581
Step.2 Mode change												
157	5785	11n20 HT4	16.38	43.45	16.48	44.46	Flat	Main	Rear (Tablet)	0	0.589	0.603
151	5755	11n40 HT4	16.32	42.85	16.43	43.95	Flat	Main	Rear (Tablet)	0	0.493	0.506
155	5775	11ac80 VHT	13.88	24.43	14.00	25.12	Flat	Main	Rear (Tablet)	0	0.235	0.242
Step.3 Channel change (Max peak SAR in Step.1 and Step.2 > 1.6 w/kg)												
153	5765	11n20 HT4	16.32	42.85	16.45	44.16	Flat	Main	Rear (Tablet)	0	0.482	0.497
161	5805	11n20 HT4	16.21	41.78	16.43	43.95	Flat	Main	Rear (Tablet)	0	0.538	0.566

*1 Reported SAR= Maximum tune-up tolerance limit [mW] / Measured maximum power [mW] · Measured SAR [W/kg]

BODY SAR MEASUREMENT RESULTS												
Frequency		Modulation	Max power(Meas)		Maximum tune-up tolerance limit		Phantom Section	EUT Set-up Conditions			Measured SAR(1g) [W/kg]	Reported SAR(1g) *1 [W/kg]
Channel	[MHz]		[dBm]	[mW]	[dBm]	[mW]		Antenna	Position	Separation [mm]	Maximum of multi-peak	Maximum of multi-peak
Step.1 Position searching												
157	5785	11a 6Mbps	16.33	42.95	16.50	44.67	Flat	Aux	Right side (Tablet)	0	0.458	0.476
157	5785	11a 6Mbps	16.33	42.95	16.50	44.67	Flat	Aux	Rear (Tablet)	0	0.494	0.514
Step.2 Mode change												
153	5765	11n20 HT4	16.4	43.65	16.48	44.46	Flat	Aux	Rear (Tablet)	0	0.369	0.376
159	5795	11n40 HT4	16.36	43.25	16.42	43.85	Flat	Aux	Rear (Tablet)	0	0.631	0.640
155	5775	11ac80 VHT	13.76	23.77	13.75	23.71	Flat	Aux	Rear (Tablet)	0	0.214	0.214
Step.3 Channel change (Max peak SAR in Step.1 and Step.2 > 1.6 w/kg)												
151	5755	11n40 HT4	16.21	41.78	16.36	43.25	Flat	Aux	Rear (Tablet)	0	0.440	0.455

*1 Reported SAR= Maximum tune-up tolerance limit [mW] / Measured maximum power [mW] · Measured SAR [W/kg]

BODY SAR MEASUREMENT RESULTS												
Frequency		Modulation	Max power(Meas)		Maximum tune-up tolerance limit		Phantom Section	EUT Set-up Conditions			Measured SAR(1g) [W/kg]	Reported SAR(1g) *1 [W/kg]
Channel	[MHz]		[dBm]	[mW]	[dBm]	[mW]		Antenna	Position	Separation [mm]	Maximum of multi-peak	Maximum of multi-peak
Step.4 11n MIMO mode												
153	5765	11n20 HT8	19.48	88.72	19.42	87.50	Flat	Main+Aux	Rear	0	0.248	0.251
151	5755	11n40 HT4	19.41	87.30	19.38	86.70	Flat	Main+Aux	Rear	0	0.214	0.215
155	5775	11ac80 VHT	17.00	50.12	16.55	45.19	Flat	Main+Aux	Rear	0	0.173	0.192

*1 Reported SAR= Maximum tune-up tolerance limit [mW] / Measured maximum power [mW] · Measured SAR [W/kg]

SECTION 10 : Simultaneous transmission SAR test exclusion considerations

10.1 Estimated SAR is calculated about Bluetooth

When standalone SAR test exclusion applies to an antenna that transmits simultaneously with other antennas, the standalone SAR must be estimated according to following to determine simultaneous transmission SAR test exclusion:

(max. power of channel, including tune-up tolerance, mW)/(min. test separation distance, mm)] · [√f(GHz)/x] W/kg for test separation distances ≤ 50 mm;

where $x = 7.5$ for 1-g SAR, and $x = 18.75$ for 10-g SAR.

0.4 W/kg for 1-g SAR and 1.0 W/kg for 10-g SAR, when the test separation distances is > 50 mm.

Test separation distances ≤ 50 mm

Position	Upper frequency of band *1	Maximum tune-up tolerance limit	Min distance *2	Calculation of Estimated SAR*3
Right side	2480 [MHz] (79 ch)	6 [dBm] 3.98 [mW]	5 [mm]	0.167 [W/kg]
Rear	2480 [MHz] (79 ch)	6 [dBm] 3.98 [mW]	9.2 [mm]	0.091 [W/kg]

Test separation distances is > 50 mm

Position	Upper frequency of band *1	Maximum tune-up tolerance limit	Min distance *2	Calculation of Estimated SAR*4
Bottom side	2480 [MHz] (79 ch)	6 [dBm] 3.98 [mW]	77 [mm]	0.400 [W/kg]

*1 The upper frequency of the frequency band of Bluetooth was used in order to calculate the maximum estimated SAR.

*2 Refer to Appendix 4. When the minimum test separation distance is < 5 mm, a distance of 5 mm is applied.

*3 $(\text{max. power of channel, including tune-up tolerance, mW})/(\text{min. test separation distance, mm}) \cdot [\sqrt{f(\text{GHz})}/x]$ W/kg

*4 Fixed value 0.4 W/kg for 1-g SAR

10.2 Result of SUM Σ SAR1g of Body

If less than 1.6W/kg of sum total values become about the SAR value of two antennas, the SAR test of simultaneous transmission will be excepted.

WLAN 2.4GHz(Main ant) + Bluetooth*3

SUM Σ SAR1g (Bluetooth + WLAN(Main ant))			
Position	Stand alone SAR(1g) [W/kg]		SUM SAR(1g)[W/kg]
	Bluetooth*2	WLAN 2.4G *1	Bluetooth + WLAN 2.4G
Right side	0.167	0.533	0.700
Bottom side	0.400	0.029	0.429
Rear	0.091	0.173	0.264

WLAN 5GHz(Main ant) + Bluetooth*3

SUM Σ SAR1g (Bluetooth + WLAN(Main ant))			
Position	Stand alone SAR(1g) [W/kg]		SUM SAR(1g)[W/kg]
	Bluetooth*2	WLAN 5G *1	Bluetooth + WLAN 5G
Right side	0.167	0.666	0.833
Bottom side	0.400	0.069	0.469
Rear	0.091	0.603	0.694

WLAN 5GHz(Aux ant) + Bluetooth*3

SUM Σ SAR1g (Bluetooth + WLAN(Main ant))			
Position	Stand alone SAR(1g) [W/kg]		SUM SAR(1g)[W/kg]
	Bluetooth*2	WLAN 5G *1	Bluetooth + WLAN 5G
Right side	0.167	0.559	0.726
Rear	0.091	0.640	0.731

*1 Use the measured SAR to determine simultaneous transmission SAR test exclusion.

*2 Use the estimated SAR to determine simultaneous transmission SAR test exclusion.

*3 WLAN 5GHz(WLAN Ant.0) can transmit simultaneously with Bluetooth(WLAN Main ant shared).

SECTION 11 Test instruments

Control No.	Instrument	Manufacturer	Model No	Serial No	Test Item	Calibration Date * Interval(month)
MOS-19	Thermo-Hygrometer	Custom	CTH-201	0001	Power	2012/12/25 * 12
MPM-09	Power Meter	Anritsu	ML2495A	6K00003348	Power	2012/10/08 * 12
MPSE-12	Power sensor	Anritsu	MA2411B	011598	Power	2012/10/08 * 12
MAT-22	Attenuator(10dB) 1-18GHz	Orient Microwave	BX10-0476-00	-	Power	2013/03/21 * 12
MSA-10	Spectrum Analyzer	Agilent	E4448A	MY46180655	Power	2013/02/22 * 12
MRENT-95	Spectrum Analyzer	Agilent	E4440A	MY46185823	Power	2013/06/14 * 12
MAT-23	Attenuator(10dB) 1-18GHz	Orient Microwave	BX10-0476-00	-	Power	2013/03/21 * 12
MPM-08	Power Meter	Anritsu	ML2495A	6K00003338	Power	2012/10/08 * 12
MPSE-11	Power sensor	Anritsu	MA2411B	011737	Power	2012/10/08 * 12
MPM-01	Power Meter	Agilent	E4417A	GB41290639	SAR	2013/04/08 * 12
MPSE-01	Power Sensor	Agilent	E9300B	US40010300	SAR	2013/03/28 * 12
MPSE-03	Power sensor	Agilent	E9327A	US40440576	SAR	2013/04/17 * 12
MAT-15	Attenuator(30dB)	Agilent	8498A	US40010300	SAR	2013/04/16 * 12
MSG-10	Signal Generator	Agilent	N5181A	MY47421098	SAR	2012/10/08 * 12
MRFA-12	RF Power Amplifier	MILMEGA	AS0825-65	1015249	SAR(0.8-2.5GHz)	2012/08/28 * 12
MRFA-08	Pre Amplifier	TSJ	TCBP0206	-	SAR(2-6GHz)	2013/03/21 * 12
MHDC-12	Dual Directional Coupler	Hewlett Packard	772D	2839A0016	SAR(2-18GHz)	Pre Check
MNA-01	Network Analyzer	Agilent/HP	E8358A	US41080381	SAR	2012/09/14 * 12
MDPK-01	Dielectric probe kit	Agilent	85070D	702	SAR	2012/08/14 * 12
MNCK-01	Type N Calibration Kit	Agilent	85032F	MY41495257	SAR	2012/09/18 * 12
MPB-07	Dosimetric E-Field Probe	Schmid&Partner Engineering AG	EX3DV4	3825	SAR	2012/12/10 * 12
MDAE-01	Data Acquisition Electronics	Schmid&Partner Engineering AG	DAE4	509	SAR	2012/07/13 * 12
COTS-MSAR-03	Dasy5	Schmid&Partner Engineering AG	DASY5	-	SAR	-
COTS-MSAR-02	S-Parameter Network Analyzer	Agilent	-	-	SAR	-
MDA-07	Dipole Antenna	Schmid&Partner Engineering AG	D2450V2	713	SAR	2010/09/06 * 36
MDA-08	Dipole Antenna	Schmid&Partner Engineering AG	D5GHzV2	1020	SAR	2013/01/11 * 12
MPF-02	2mmOval Flat Phantom ERI 4.0	Schmid&Partner Engineering AG	QD VA 001B (ERI4.0)	1045	SAR	2012/05/08 * 12
MOS-26	Thermo-Hygrometer	CUSTOM	CTH-201	A08Q29	SAR	2012/05/14 * 12
MOS-10	Digital thermometer	HANNA	Checktemp-2	MOS-10	SAR	2012/08/06 * 12
MBM-13	Barometer	Sunoh	SBR121	837	SAR	2011/03/14 * 36
MSL2450					Daily check	Target value \pm 5%
MSL 5GHz(BR)					Daily check	Target value \pm 5%
SAR room					Daily check	Ambient Noise<0.012W/kg

The expiration date of the calibration is the end of the expired month.

All equipment is calibrated with valid calibrations. Each measurement data is traceable to the national or international standards.

As for some calibrations performed after the tested dates, those test equipment have been controlled by means of an unbroken chains of calibrations.

APPENDIX 1 : SAR Measurement data

1. Evaluation procedure

The evaluation was performed with the following procedure:

Step 1: Measurement of the E-field at a fixed location above the ear point or central position of flat phantom was used as a reference value for assessing the power drop.

Step 2: The SAR distribution at the exposed side of head or body position was measured at a distance of each device from the inner surface of the shell. The area covered the entire dimension of the antenna of EUT and the horizontal grid spacing was 15 mm x 15 mm, 12 mm x 12 mm or 10mm x 10mm. Based on these data, the area of the maximum absorption was determined by spline interpolation.

Step 3: Around this point found in the Step 2 (area scan), a volume of 30mm x 30mm x 30mm or more was assessed by measuring 7 x 7 x 7 points at least for below 3GHz and a volume of 28 mm x 28mm x 22.5mm or more was assessed by measuring 8 x 8 x 6(ratio step method (*1)) points at least for 5GHz band.

And for any secondary peaks found in the Step2 which are within 2dB of maximum peak and not with this Step3 (Zoom scan) is repeated. On the basis of this data set, the spatial peak SAR value was evaluated under the following procedure:

(1). The data at the surface were extrapolated, since the center of the dipoles is 1mm(EX3DV4) away from the tip of the probe and the distance between the surface and the lowest measuring point is 1.3 mm. The extrapolation was based on a least square algorithm [4]. A polynomial of the fourth order was calculated through the points in z-axes.

This polynomial was then used to evaluate the points between the surface and the probe tip.

(2). The maximum interpolated value was searched with a straightforward algorithm. Around this maximum the SAR values averaged over the spatial volumes (1 g or 10 g) were computed by the 3D-Spline interpolation algorithm. The 3D-Spline is composed of three one-dimensional splines with the "Not a knot"-condition (in x, y and z-directions) [4], [5]. The volume was integrated with the trapezoidal-algorithm. One thousand points (10 x 10 x 10) were interpolated to calculate the average.

(3). All neighboring volumes were evaluated until no neighboring volume with a higher average value was found.

Step 4: Re-measurement of the E-field at the same location as in Step 1.

***1. Ratio step method parameters used;**

The first measurement point: 2mm from the phantom surface, the initial grid separation: 2mm, subsequent graded grid ratio: 1.5

These parameters comply with the requirement of the KDB 865664.

In the section of SAR Scan Procedures-Zoom Scan, in KDB 865664 D02v01: SAR Measurement Requirements for 100MHz to 6GHz, the graded grids requirement is as follows;

“When graded grids are used (z), the first measurement point should be within 3mm of the phantom surface for measurements below 4.5GHz and within 2mm at or above 4.5GHz. The initial grid separation, closest to the phantom, should be 2.0mm. A subsequent graded ration of 1.5 is recommended and less than 2.0 is required.”

2. Measurement data

i) WLAN 2.4GHz

WLAN 11g 6Mbps 2437MHz Right side 0mm Ant. Main

Communication System: UID 0, WLAN 11a/b/g/n ; Communication System Band: WLAN 11b/g/n; Frequency: 2437 MHz; Communication System PAR: 0 dB; PMF: 1.12202e-005

Medium parameters used (interpolated): $f = 2437$ MHz; $\sigma = 1.991$ S/m; $\epsilon_r = 50.808$; $\rho = 1000$ kg/m³

Phantom section: Flat Section

Measurement Standard: DASYS5 (IEEE/IEC/ANSI C63.19-2007)

DASY Configuration:

Probe: EX3DV4 - SN3825; ConvF(7.33, 7.33, 7.33); Calibrated: 2012/12/10;

Modulation Compensation:

Sensor-Surface: 2mm (Mechanical Surface Detection), $z = 1.0, 31.0$

Electronics: DAE4 Sn509; Calibrated: 2012/07/13

Phantom: ELI 4.0; Type: QDOVA001BA;

DASY52 52.8.7(1137); SEMCAD X 14.6.10(7164)

Area Scan (101x101x1): Interpolated grid: $dx=1.200$ mm, $dy=1.200$ mm

Maximum value of SAR (interpolated) = 0.899 W/kg

Zoom Scan (7x7x7)/Cube 0: Measurement grid: $dx=5$ mm, $dy=5$ mm, $dz=5$ mm

Reference Value = 20.463 V/m; Power Drift = -0.03 dB

Peak SAR (extrapolated) = 1.27 W/kg

SAR(1 g) = 0.493 W/kg; SAR(10 g) = 0.184 W/kg

Maximum value of SAR (measured) = 0.870 W/kg

Date: 2013/05/29

Ambient Temp. : 24.5 degree.C. Liquid Temp. ; 24.0 degree.C.

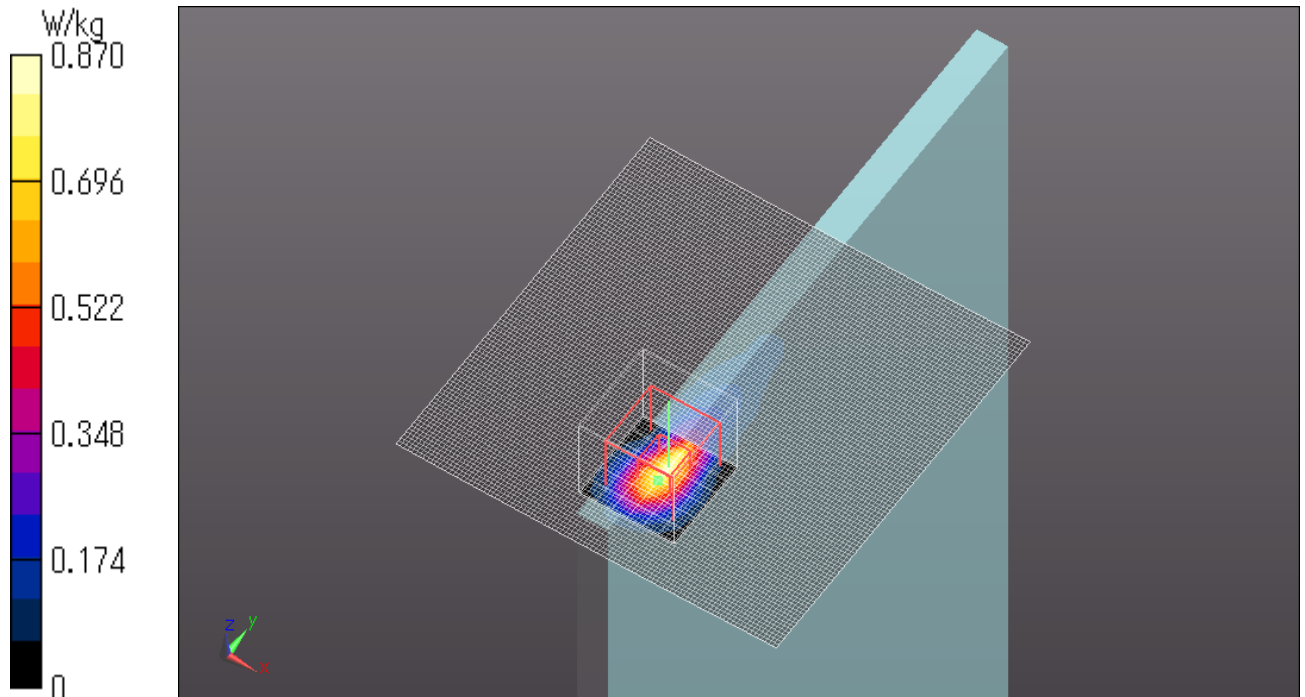

WLAN 11g 6Mbps 2437MHz Bottom side 0mm Ant. Main

Communication System: UID 0, WLAN 11a/b/g/n ; Communication System Band: WLAN 11b/g/n; Frequency: 2437 MHz; Communication System PAR: 0 dB; PMF: 1.12202e-005
Medium parameters used (interpolated): $f = 2437$ MHz; $\sigma = 1.991$ S/m; $\epsilon_r = 50.808$; $\rho = 1000$ kg/m³
Phantom section: Flat Section
Measurement Standard: DASY5 (IEEE/IEC/ANSI C63.19-2007)
DASY Configuration:
Probe: EX3DV4 - SN3825; ConvF(7.33, 7.33, 7.33); Calibrated: 2012/12/10;
Modulation Compensation:
Sensor-Surface: 2mm (Mechanical Surface Detection), $z = 1.0, 31.0$
Electronics: DAE4 Sn509; Calibrated: 2012/07/13
Phantom: ELI 4.0; Type: QDOVA001BA;
DASY52 52.8.7(1137); SEMCAD X 14.6.10(7164)

Area Scan (101x121x1): Interpolated grid: $dx=1.200$ mm, $dy=1.200$ mm
Maximum value of SAR (interpolated) = 0.0745 W/kg

Zoom Scan (8x9x7)/Cube 0: Measurement grid: $dx=5$ mm, $dy=5$ mm, $dz=5$ mm
Reference Value = 5.017 V/m; Power Drift = -0.17 dB
Peak SAR (extrapolated) = 0.0610 W/kg
SAR(1 g) = 0.027 W/kg; SAR(10 g) = 0.00869 W/kg
Maximum value of SAR (measured) = 0.0479 W/kg

Date: 2013/05/29

Ambient Temp. : 24.5 degree.C. Liquid Temp. ; 24.0 degree.C.

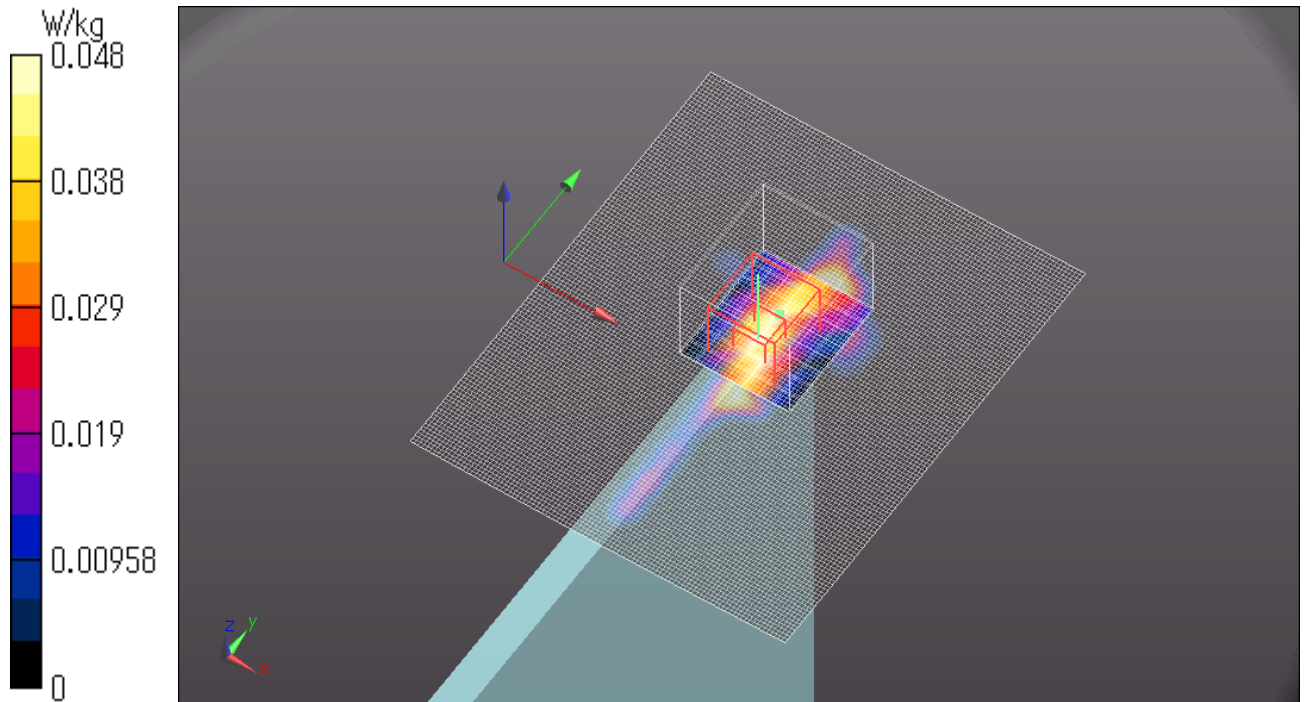

WLAN 11g 6Mbps 2437MHz Rear 0mm Ant. Main

Communication System: UID 0, WLAN 11a/b/g/n ; Communication System Band: WLAN 11b/g/n; Frequency: 2437 MHz; Communication System PAR: 0 dB; PMF: 1.12202e-005
Medium parameters used (interpolated): $f = 2437$ MHz; $\sigma = 1.991$ S/m; $\epsilon_r = 50.808$; $\rho = 1000$ kg/m³
Phantom section: Flat Section
Measurement Standard: DASY5 (IEEE/IEC/ANSI C63.19-2007)
DASY Configuration:
Probe: EX3DV4 - SN3825; ConvF(7.33, 7.33, 7.33); Calibrated: 2012/12/10;
Modulation Compensation:
Sensor-Surface: 2mm (Mechanical Surface Detection), $z = 1.0, 31.0$
Electronics: DAE4 Sn509; Calibrated: 2012/07/13
Phantom: ELI 4.0; Type: QDOVA001BA;
DASY52 52.8.7(1137); SEMCAD X 14.6.10(7164)

Area Scan 2 (121x101x1): Interpolated grid: $dx=1.200$ mm, $dy=1.200$ mm
Maximum value of SAR (interpolated) = 0.266 W/kg

Zoom Scan (7x7x7)/Cube 0: Measurement grid: $dx=5$ mm, $dy=5$ mm, $dz=5$ mm
Reference Value = 11.287 V/m; Power Drift = 0.01 dB
Peak SAR (extrapolated) = 0.348 W/kg
SAR(1 g) = 0.160 W/kg; SAR(10 g) = 0.067 W/kg
Maximum value of SAR (measured) = 0.250 W/kg

Date: 2013/05/29

Ambient Temp. : 24.5 degree.C. Liquid Temp. ; 24.0 degree.C.

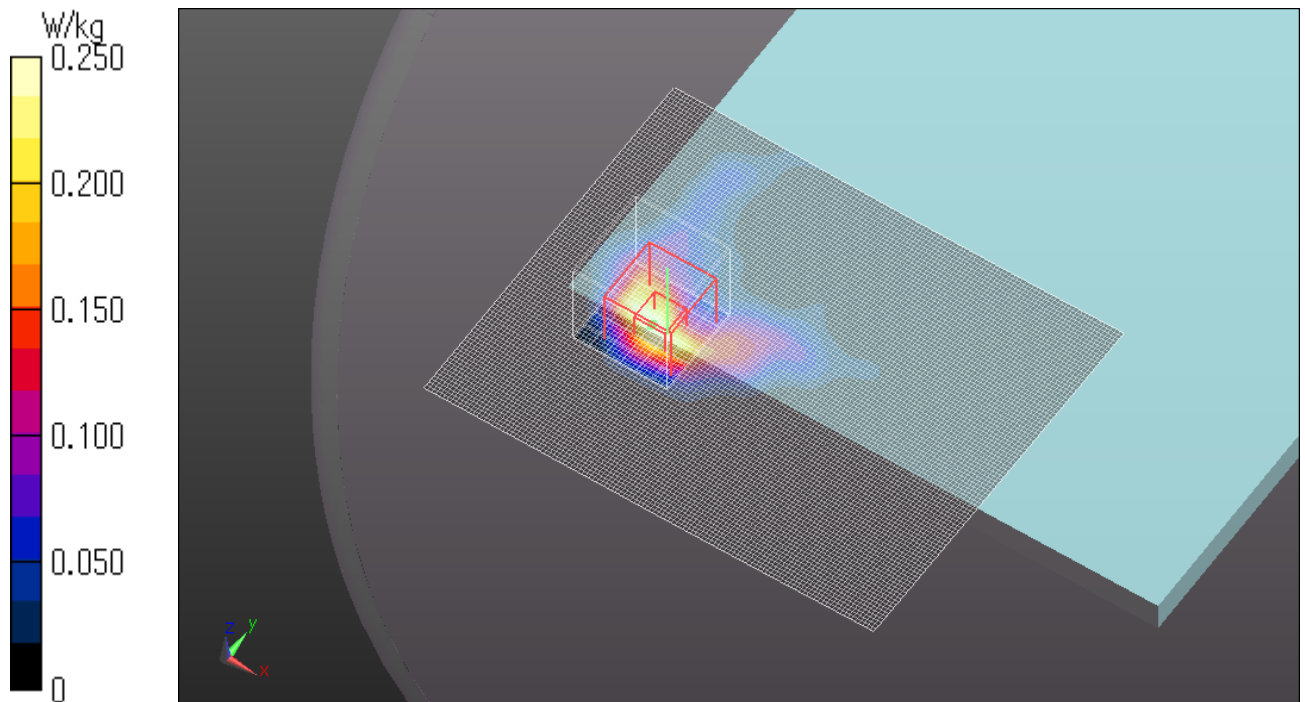

WLAN 11b 1Mbps 2437MHz Right side 0mm Ant.Main

Communication System: UID 0, WLAN 11a/b/g/n ; Communication System Band: WLAN 11b/g/n; Frequency: 2437 MHz; Communication System PAR: 0 dB; PMF: 1.12202e-005
Medium parameters used (interpolated): $f = 2437$ MHz; $\sigma = 1.991$ S/m; $\epsilon_r = 50.808$; $\rho = 1000$ kg/m³
Phantom section: Flat Section
Measurement Standard: DASY5 (IEEE/IEC/ANSI C63.19-2007)
DASY Configuration:
Probe: EX3DV4 - SN3825; ConvF(7.33, 7.33, 7.33); Calibrated: 2012/12/10;
Modulation Compensation:
Sensor-Surface: 2mm (Mechanical Surface Detection), $z = 1.0, 31.0$
Electronics: DAE4 Sn509; Calibrated: 2012/07/13
Phantom: ELI 4.0; Type: QDOVA001BA;
DASY52 52.8.7(1137); SEMCAD X 14.6.10(7164)

Area Scan (101x121x1): Interpolated grid: $dx=1.200$ mm, $dy=1.200$ mm
Maximum value of SAR (interpolated) = 0.677 W/kg

Zoom Scan (7x7x7)/Cube 0: Measurement grid: $dx=5$ mm, $dy=5$ mm, $dz=5$ mm
Reference Value = 1.242 V/m; Power Drift = 0.19 dB
Peak SAR (extrapolated) = 1.03 W/kg
SAR(1 g) = 0.410 W/kg; SAR(10 g) = 0.156 W/kg
Maximum value of SAR (measured) = 0.713 W/kg

Date: 2013/05/29

Ambient Temp. : 24.5 degree.C. Liquid Temp. ; 24.0 degree.C.

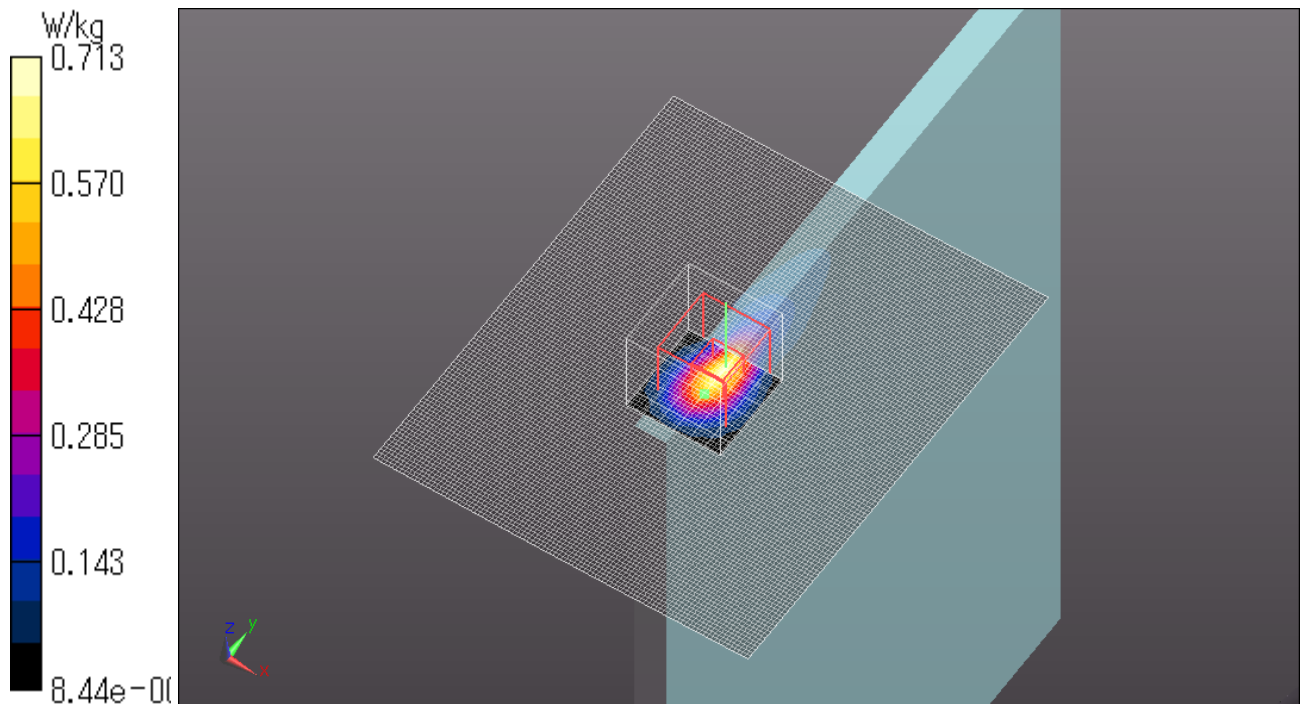

WLAN 11n20 HT4 2437MHz Right side 0mm Ant. Main

Communication System: UID 0, WLAN 11a/b/g/n ; Communication System Band: WLAN 11b/g/n; Frequency: 2437 MHz; Communication System PAR: 0 dB; PMF: 1.12202e-005
Medium parameters used (interpolated): $f = 2437$ MHz; $\sigma = 1.991$ S/m; $\epsilon_r = 50.808$; $\rho = 1000$ kg/m³
Phantom section: Flat Section
Measurement Standard: DASY5 (IEEE/IEC/ANSI C63.19-2007)
DASY Configuration:
Probe: EX3DV4 - SN3825; ConvF(7.33, 7.33, 7.33); Calibrated: 2012/12/10;
Modulation Compensation:
Sensor-Surface: 2mm (Mechanical Surface Detection (Locations From Previous Scan Used)), Sensor-Surface: 2mm (Mechanical Surface Detection), $z = 1.0, 31.0$
Electronics: DAE4 Sn509; Calibrated: 2012/07/13
Phantom: ELI 4.0; Type: QDOVA001BA;
DASY52 52.8.7(1137); SEMCAD X 14.6.10(7164)

Area Scan (101x121x1): Interpolated grid: $dx=1.200$ mm, $dy=1.200$ mm
Maximum value of SAR (interpolated) = 0.918 W/kg

Zoom Scan (7x7x7)/Cube 0: Measurement grid: $dx=5$ mm, $dy=5$ mm, $dz=5$ mm
Reference Value = 1.729 V/m; Power Drift = 0.16 dB
Peak SAR (extrapolated) = 1.35 W/kg
SAR(1 g) = 0.534 W/kg; SAR(10 g) = 0.203 W/kg
Maximum value of SAR (measured) = 0.907 W/kg

Date: 2013/05/29

Ambient Temp. : 24.5 degree.C. Liquid Temp. ; 24.0 degree.C.

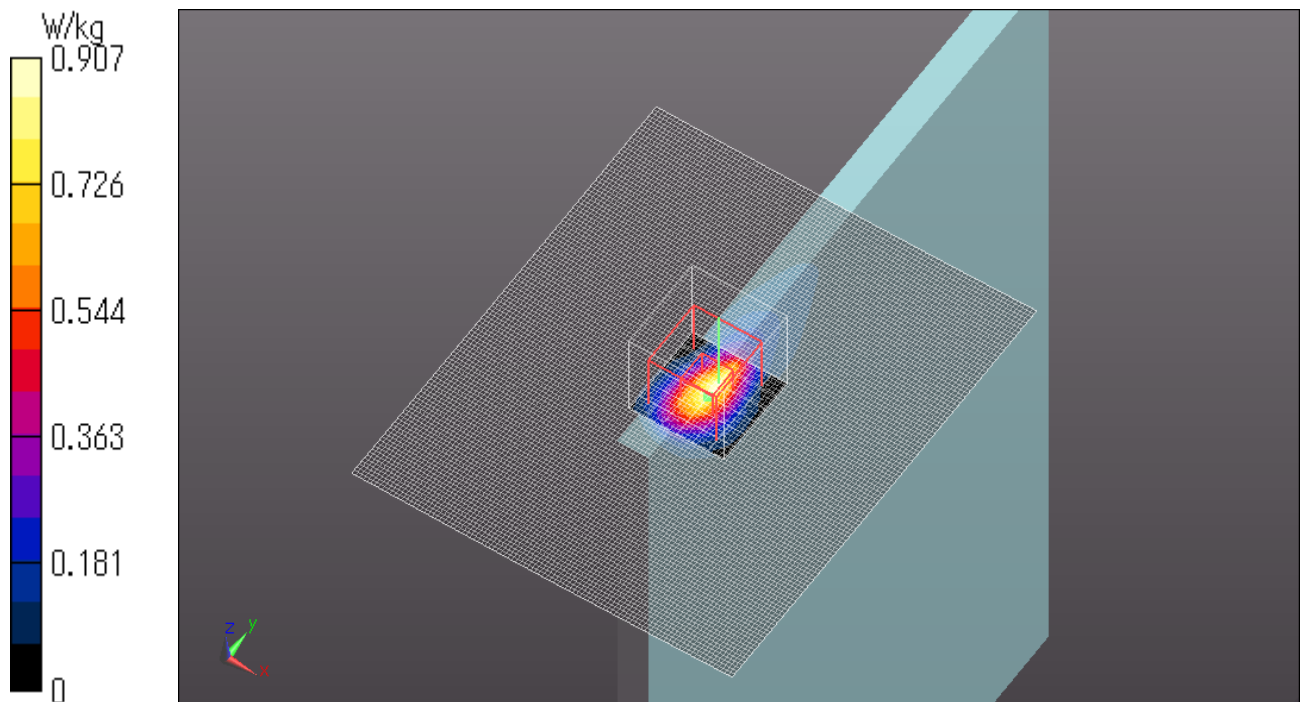

WLAN 11n40 HT4 2437MHz Right side Ant. Main

Communication System: UID 0, WLAN 11a/b/g/n ; Communication System Band: WLAN 11b/g/n; Frequency: 2437 MHz; Communication System PAR: 0 dB; PMF: 1.12202e-005

Medium parameters used (interpolated): $f = 2437$ MHz; $\sigma = 1.991$ S/m; $\epsilon_r = 50.808$; $\rho = 1000$ kg/m³

Phantom section: Flat Section

Measurement Standard: DASY5 (IEEE/IEC/ANSI C63.19-2007)

DASY Configuration:

Probe: EX3DV4 - SN3825; ConvF(7.33, 7.33, 7.33); Calibrated: 2012/12/10;

Modulation Compensation:

Sensor-Surface: 2mm (Mechanical Surface Detection (Locations From Previous Scan Used)), Sensor-Surface: 2mm (Mechanical Surface Detection), $z = 1.0, 31.0$

Electronics: DAE4 Sn509; Calibrated: 2012/07/13

Phantom: ELI 4.0; Type: QDOVA001BA;

DASY52 52.8.7(1137); SEMCAD X 14.6.10(7164)

Area Scan (101x121x1): Interpolated grid: $dx=1.200$ mm, $dy=1.200$ mm

Maximum value of SAR (interpolated) = 1.27 W/kg

Zoom Scan (7x7x7)/Cube 0: Measurement grid: $dx=5$ mm, $dy=5$ mm, $dz=5$ mm

Reference Value = 1.847 V/m; Power Drift = 0.10 dB

Peak SAR (extrapolated) = 1.56 W/kg

SAR(1 g) = 0.608 W/kg; SAR(10 g) = 0.231 W/kg

Maximum value of SAR (measured) = 1.06 W/kg

Date: 2013/05/29

Ambient Temp. : 24.5 degree.C. Liquid Temp. ; 24.0 degree.C.

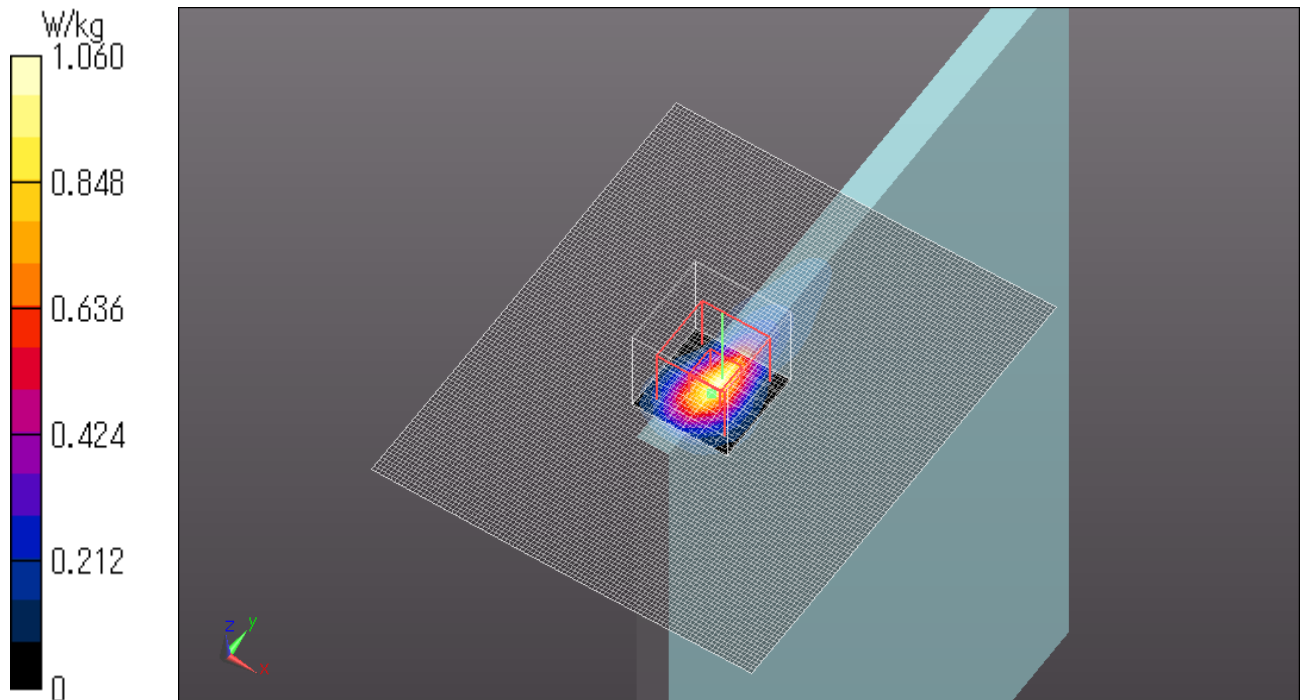

Z Scan at Maximum Body SAR position in WLAN 2.4GHz

WLAN 11n40 HT4 2437MHz Right side 0mm Ant. Main

Communication System: UID 0, WLAN 11a/b/g/n ; Communication System Band: WLAN 11b/g/n; Frequency: 2437 MHz; Communication System PAR: 0 dB; PMF: 1.12202e-005

Medium parameters used (interpolated): $f = 2437$ MHz; $\sigma = 1.991$ S/m; $\epsilon_r = 50.808$; $\rho = 1000$ kg/m³

Phantom section: Flat Section

Measurement Standard: DASY5 (IEEE/IEC/ANSI C63.19-2007)

DASY Configuration:

Probe: EX3DV4 - SN3825; ConvF(7.33, 7.33, 7.33); Calibrated: 2012/12/10;

Modulation Compensation:

Sensor-Surface: 2mm (Mechanical Surface Detection), $z = 151.0$

Electronics: DAE4 Sn509; Calibrated: 2012/07/13

Phantom: ELI 4.0; Type: QDOVA001BA;

DASY52 52.8.7(1137); SEMCAD X 14.6.10(7164)

Z Scan (1x1x31): Measurement grid: $dx=20$ mm, $dy=20$ mm, $dz=5$ mm

Maximum value of SAR (measured) = 0.826 W/kg

Date: 2013/05/29

Ambient Temp. : 24.5 degree.C. Liquid Temp. ; 24.0 degree.C.

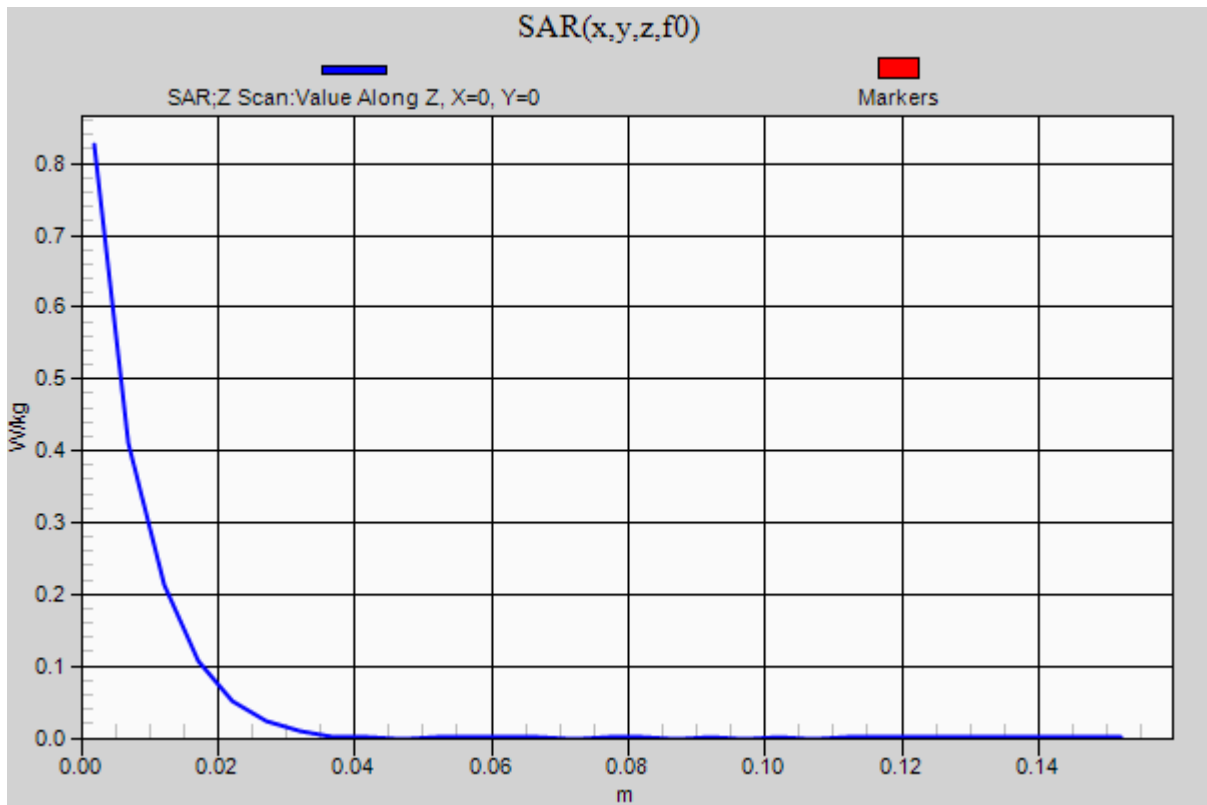

WLAN 11g 6Mbps 2437MHz Right side 0mm Ant. Aux

Communication System: UID 0, WLAN 11a/b/g/n ; Communication System Band: WLAN 11b/g/n; Frequency: 2437 MHz; Communication System PAR: 0 dB; PMF: 1.12202e-005
Medium parameters used (interpolated): $f = 2437$ MHz; $\sigma = 1.991$ S/m; $\epsilon_r = 50.808$; $\rho = 1000$ kg/m³
Phantom section: Flat Section
Measurement Standard: DASY5 (IEEE/IEC/ANSI C63.19-2007)
DASY Configuration:
Probe: EX3DV4 - SN3825; ConvF(7.33, 7.33, 7.33); Calibrated: 2012/12/10;
Modulation Compensation:
Sensor-Surface: 2mm (Mechanical Surface Detection), $z = 1.0, 31.0$
Electronics: DAE4 Sn509; Calibrated: 2012/07/13
Phantom: ELI 4.0; Type: QDOVA001BA;
DASY52 52.8.7(1137); SEMCAD X 14.6.10(7164)

Area Scan (101x101x1): Interpolated grid: $dx=1.200$ mm, $dy=1.200$ mm
Maximum value of SAR (interpolated) = 0.444 W/kg

Zoom Scan (7x7x7)/Cube 0: Measurement grid: $dx=5$ mm, $dy=5$ mm, $dz=5$ mm
Reference Value = 14.518 V/m; Power Drift = 0.04 dB
Peak SAR (extrapolated) = 0.716 W/kg
SAR(1 g) = 0.271 W/kg; SAR(10 g) = 0.118 W/kg
Maximum value of SAR (measured) = 0.450 W/kg

Date: 2013/05/29

Ambient Temp. : 24.5 degree.C. Liquid Temp. ; 24.0 degree.C.

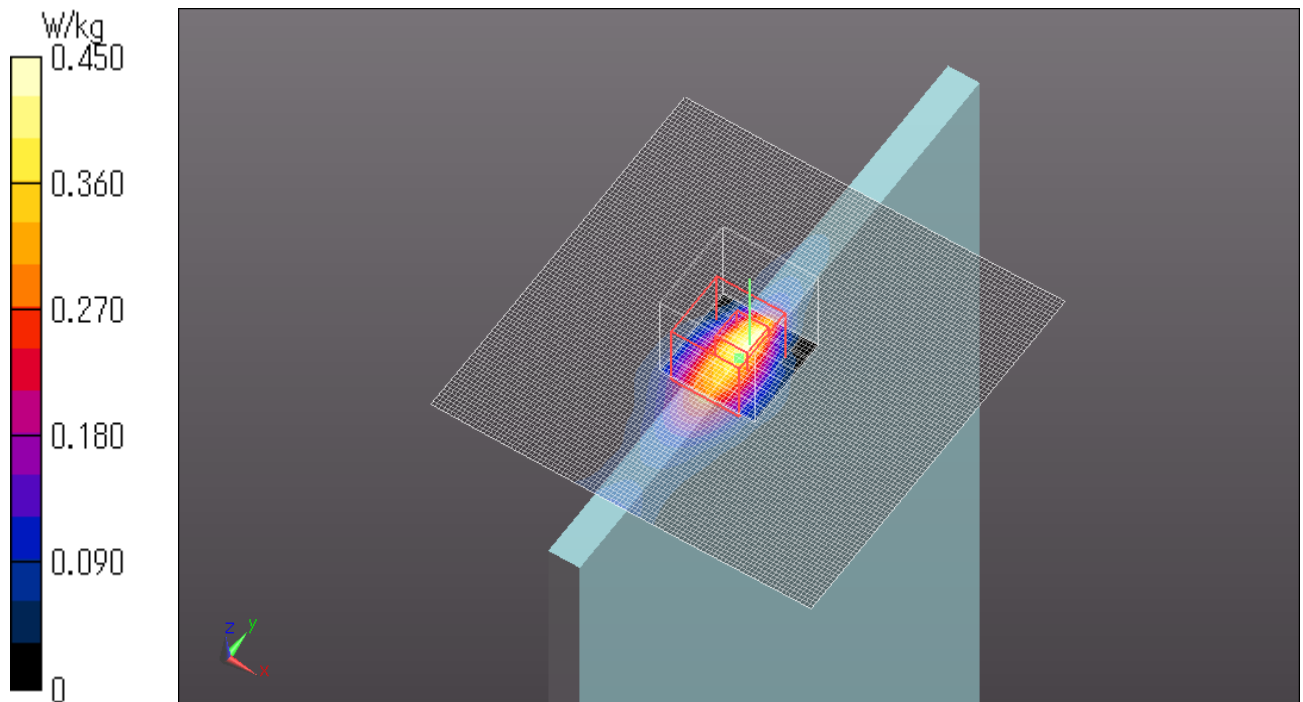

WLAN 11g 6Mbps 2437MHz Rear 0mm Ant. Aux

Communication System: UID 0, WLAN 11a/b/g/n ; Communication System Band: WLAN 11b/g/n; Frequency: 2437 MHz; Communication System PAR: 0 dB; PMF: 1.12202e-005
Medium parameters used (interpolated): $f = 2437$ MHz; $\sigma = 1.991$ S/m; $\epsilon_r = 50.808$; $\rho = 1000$ kg/m³
Phantom section: Flat Section
Measurement Standard: DASY5 (IEEE/IEC/ANSI C63.19-2007)
DASY Configuration:
Probe: EX3DV4 - SN3825; ConvF(7.33, 7.33, 7.33); Calibrated: 2012/12/10;
Modulation Compensation:
Sensor-Surface: 2mm (Mechanical Surface Detection), $z = 1.0, 31.0$
Electronics: DAE4 Sn509; Calibrated: 2012/07/13
Phantom: ELI 4.0; Type: QDOVA001BA;
DASY52 52.8.7(1137); SEMCAD X 14.6.10(7164)

Area Scan (121x101x1): Interpolated grid: $dx=1.200$ mm, $dy=1.200$ mm
Maximum value of SAR (interpolated) = 0.390 W/kg

Zoom Scan (7x7x7)/Cube 0: Measurement grid: $dx=5$ mm, $dy=5$ mm, $dz=5$ mm
Reference Value = 0.356 V/m; Power Drift = -0.03 dB
Peak SAR (extrapolated) = 0.502 W/kg
SAR(1 g) = 0.209 W/kg; SAR(10 g) = 0.093 W/kg
Maximum value of SAR (measured) = 0.338 W/kg

Date: 2013/05/29

Ambient Temp. : 24.5 degree.C. Liquid Temp. ; 24.0 degree.C.

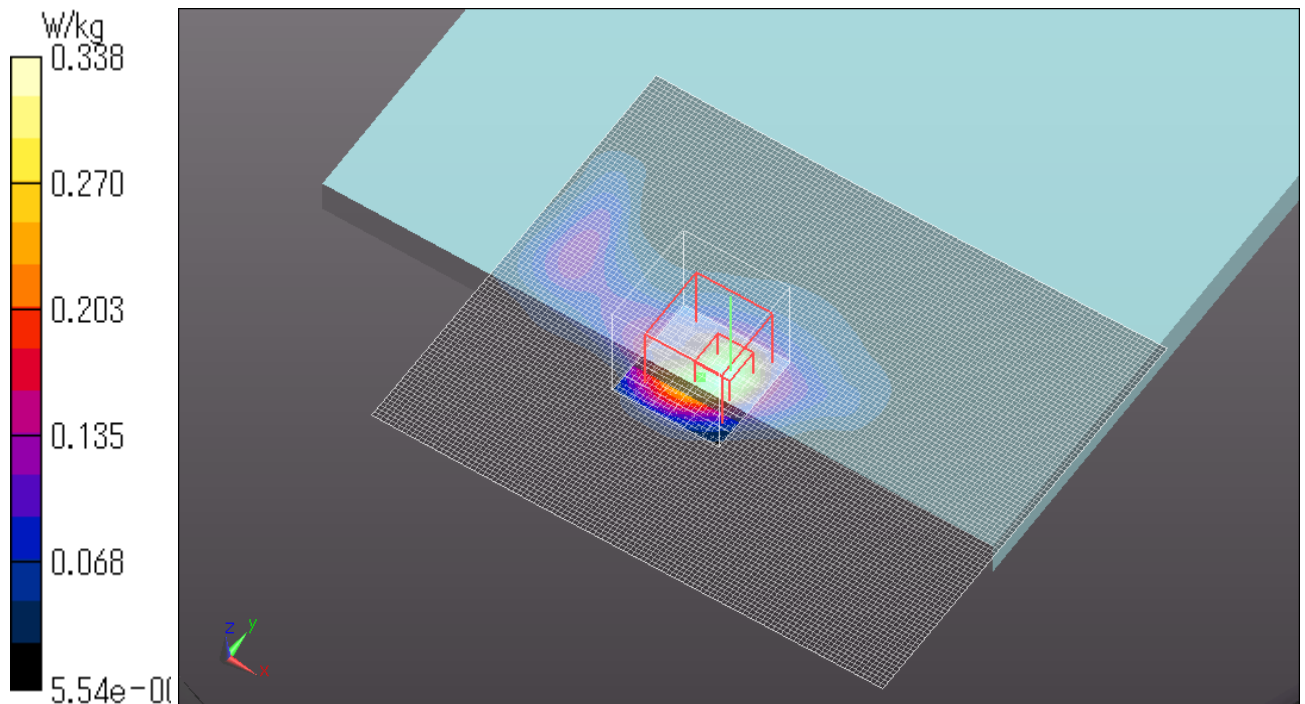

WLAN 11b 1Mbps 2437MHz Right side 0mm Ant. Aux

Communication System: UID 0, WLAN 11a/b/g/n ; Communication System Band: WLAN 11b/g/n; Frequency: 2437 MHz; Communication System PAR: 0 dB; PMF: 1.12202e-005
Medium parameters used (interpolated): $f = 2437$ MHz; $\sigma = 1.991$ S/m; $\epsilon_r = 50.808$; $\rho = 1000$ kg/m³
Phantom section: Flat Section
Measurement Standard: DASY5 (IEEE/IEC/ANSI C63.19-2007)
DASY Configuration:
Probe: EX3DV4 - SN3825; ConvF(7.33, 7.33, 7.33); Calibrated: 2012/12/10;
Modulation Compensation:
Sensor-Surface: 2mm (Mechanical Surface Detection), $z = 1.0, 31.0$
Electronics: DAE4 Sn509; Calibrated: 2012/07/13
Phantom: ELI 4.0; Type: QDOVA001BA;
DASY52 52.8.7(1137); SEMCAD X 14.6.10(7164)

Area Scan (101x101x1): Interpolated grid: $dx=1.200$ mm, $dy=1.200$ mm
Maximum value of SAR (interpolated) = 0.286 W/kg

Zoom Scan (7x7x7)/Cube 0: Measurement grid: $dx=5$ mm, $dy=5$ mm, $dz=5$ mm
Reference Value = 9.964 V/m; Power Drift = 0.18 dB
Peak SAR (extrapolated) = 0.350 W/kg
SAR(1 g) = 0.134 W/kg; SAR(10 g) = 0.057 W/kg
Maximum value of SAR (measured) = 0.239 W/kg

Date: 2013/05/29

Ambient Temp. : 24.5 degree.C. Liquid Temp. ; 24.0 degree.C.

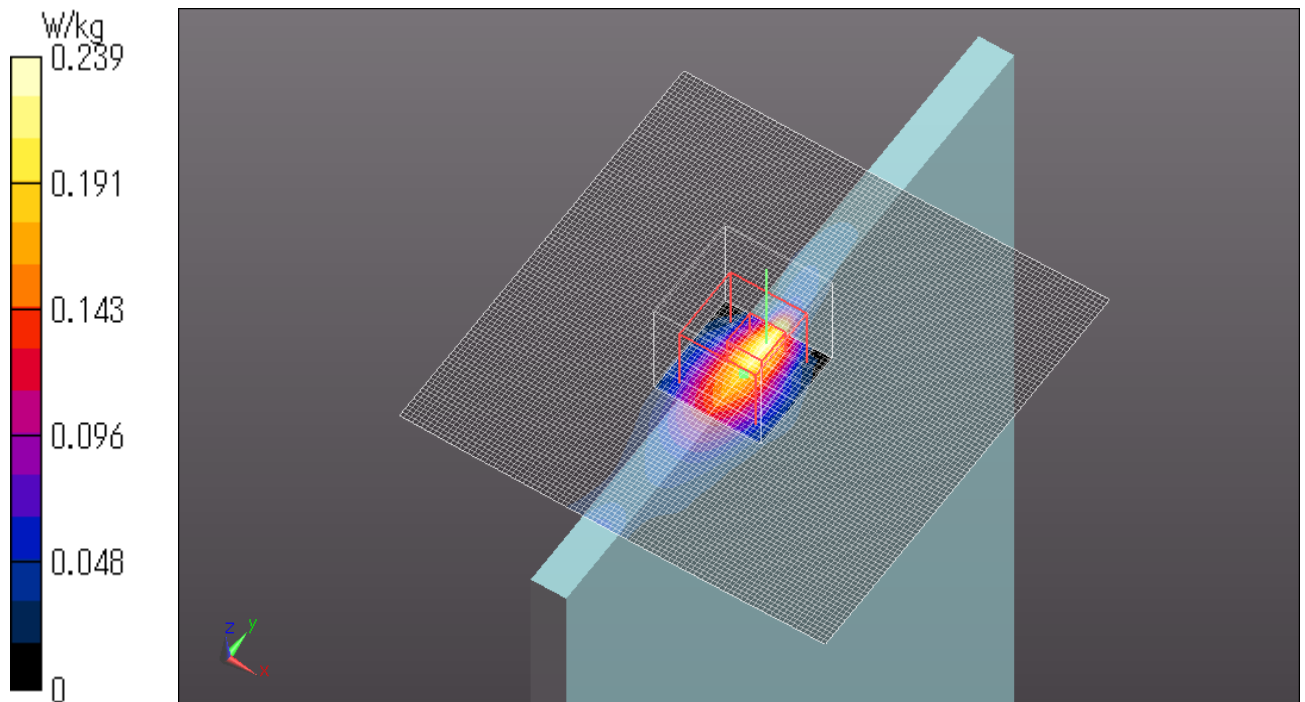

WLAN 11n20 HT4 2437MHz Right side 0mm Ant. Aux

Communication System: UID 0, WLAN 11a/b/g/n ; Communication System Band: WLAN 11b/g/n; Frequency: 2437 MHz; Communication System PAR: 0 dB; PMF: 1.12202e-005

Medium parameters used (interpolated): $f = 2437$ MHz; $\sigma = 1.991$ S/m; $\epsilon_r = 50.808$; $\rho = 1000$ kg/m³

Phantom section: Flat Section

Measurement Standard: DASY5 (IEEE/IEC/ANSI C63.19-2007)

DASY Configuration:

Probe: EX3DV4 - SN3825; ConvF(7.33, 7.33, 7.33); Calibrated: 2012/12/10;

Modulation Compensation:

Sensor-Surface: 2mm (Mechanical Surface Detection (Locations From Previous Scan Used)), Sensor-Surface: 2mm (Mechanical Surface Detection), $z = 1.0, 31.0$

Electronics: DAE4 Sn509; Calibrated: 2012/07/13

Phantom: ELI 4.0; Type: QDOVA001BA;

DASY52 52.8.7(1137); SEMCAD X 14.6.10(7164)

Area Scan (101x101x1): Interpolated grid: $dx=1.200$ mm, $dy=1.200$ mm

Maximum value of SAR (interpolated) = 0.439 W/kg

Zoom Scan (7x7x7)/Cube 0: Measurement grid: $dx=5$ mm, $dy=5$ mm, $dz=5$ mm

Reference Value = 13.923 V/m; Power Drift = -0.00 dB

Peak SAR (extrapolated) = 0.700 W/kg

SAR(1 g) = 0.267 W/kg; SAR(10 g) = 0.114 W/kg

Maximum value of SAR (measured) = 0.476 W/kg

Date: 2013/05/29

Ambient Temp. : 24.5 degree.C. Liquid Temp. ; 24.0 degree.C.

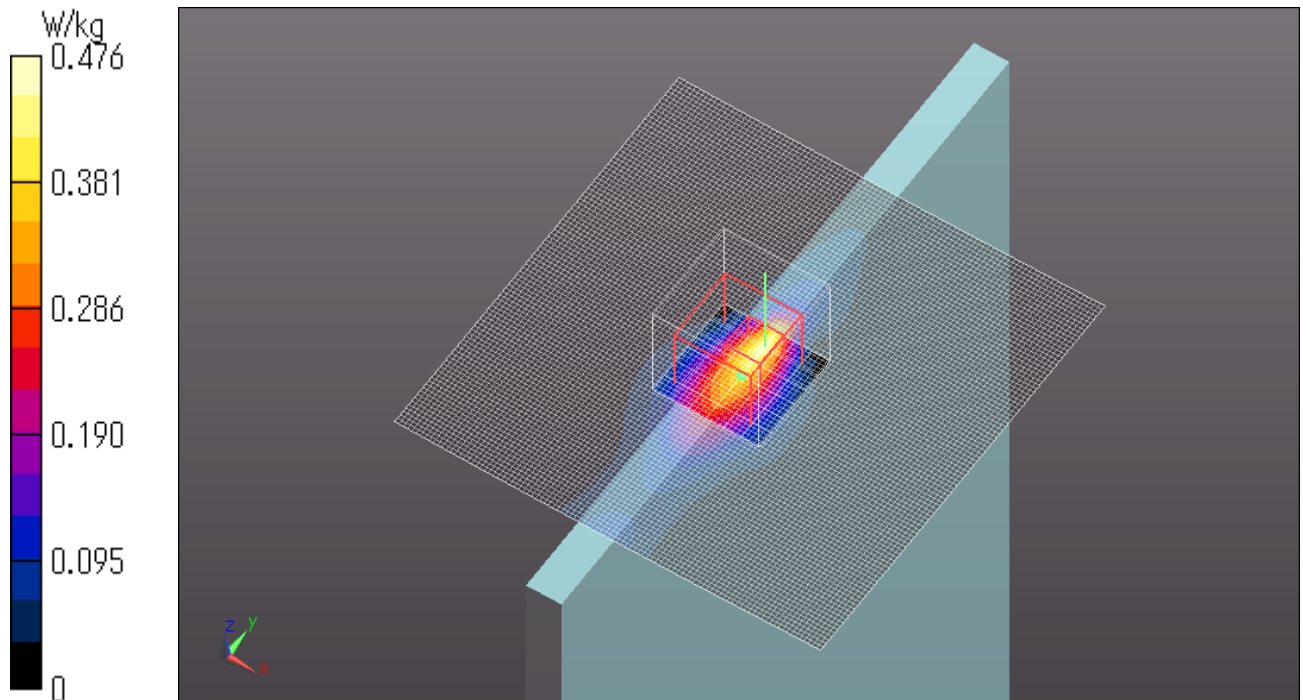

WLAN 11n40 HT4 2437MHz Right side 0mm Ant. Aux

Communication System: UID 0, WLAN 11a/b/g/n ; Communication System Band: WLAN 11b/g/n; Frequency: 2437 MHz; Communication System PAR: 0 dB; PMF: 1.12202e-005

Medium parameters used (interpolated): $f = 2437$ MHz; $\sigma = 1.991$ S/m; $\epsilon_r = 50.808$; $\rho = 1000$ kg/m³

Phantom section: Flat Section

Measurement Standard: DASY5 (IEEE/IEC/ANSI C63.19-2007)

DASY Configuration:

Probe: EX3DV4 - SN3825; ConvF(7.33, 7.33, 7.33); Calibrated: 2012/12/10;

Modulation Compensation:

Sensor-Surface: 2mm (Mechanical Surface Detection (Locations From Previous Scan Used)), Sensor-Surface: 2mm (Mechanical Surface Detection), $z = 1.0, 31.0$

Electronics: DAE4 Sn509; Calibrated: 2012/07/13

Phantom: ELI 4.0; Type: QDOVA001BA;

DASY52 52.8.7(1137); SEMCAD X 14.6.10(7164)

Area Scan (101x101x1): Interpolated grid: $dx=1.200$ mm, $dy=1.200$ mm

Maximum value of SAR (interpolated) = 0.296 W/kg

Zoom Scan (7x7x7)/Cube 0: Measurement grid: $dx=5$ mm, $dy=5$ mm, $dz=5$ mm

Reference Value = 11.506 V/m; Power Drift = -0.07 dB

Peak SAR (extrapolated) = 0.474 W/kg

SAR(1 g) = 0.181 W/kg; SAR(10 g) = 0.077 W/kg

Maximum value of SAR (measured) = 0.323 W/kg

Date: 2013/05/29

Ambient Temp. : 24.5 degree.C. Liquid Temp. ; 24.0 degree.C.

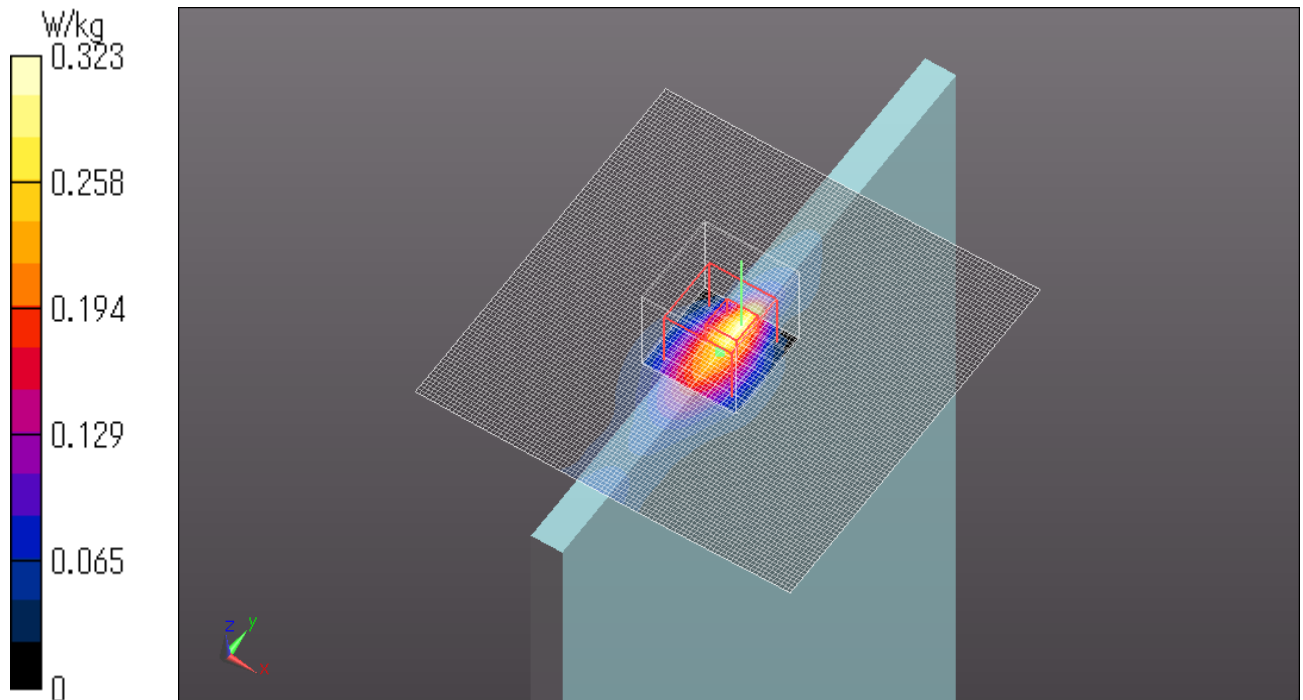

WLAN 11n20 HT8 2437MHz Right side 0mm Ant. Main and Aux

Communication System: UID 0, WLAN 11a/b/g/n ; Communication System Band: WLAN 11b/g/n; Frequency: 2437 MHz; Communication System PAR: 0 dB; PMF: 1.12202e-005
Medium parameters used (interpolated): $f = 2437$ MHz; $\sigma = 1.991$ S/m; $\epsilon_r = 50.808$; $\rho = 1000$ kg/m³
Phantom section: Flat Section
Measurement Standard: DASYS5 (IEEE/IEC/ANSI C63.19-2007)
DASY Configuration:
Probe: EX3DV4 - SN3825; ConvF(7.33, 7.33, 7.33); Calibrated: 2012/12/10;
Modulation Compensation:
Sensor-Surface: 2mm (Mechanical Surface Detection), $z = 1.0, 31.0$
Electronics: DAE4 Sn509; Calibrated: 2012/07/13
Phantom: ELI 4.0; Type: QDOVA001BA;
DASY52 52.8.7(1137); SEMCAD X 14.6.10(7164)

Area Scan 2 (51x121x1): Interpolated grid: $dx=1.200$ mm, $dy=1.200$ mm
Maximum value of SAR (interpolated) = 0.895 W/kg

Zoom Scan 2 (7x7x7)/Cube 0: Measurement grid: $dx=5$ mm, $dy=5$ mm, $dz=5$ mm
Reference Value = 21.629 V/m; Power Drift = -0.11 dB
Peak SAR (extrapolated) = 1.31 W/kg
SAR(1 g) = 0.519 W/kg; SAR(10 g) = 0.205 W/kg
Maximum value of SAR (measured) = 0.883 W/kg

Zoom Scan (7x7x7)/Cube 0: Measurement grid: $dx=5$ mm, $dy=5$ mm, $dz=5$ mm
Reference Value = 21.629 V/m; Power Drift = -0.11 dB
Peak SAR (extrapolated) = 0.743 W/kg
SAR(1 g) = 0.288 W/kg; SAR(10 g) = 0.137 W/kg
Maximum value of SAR (measured) = 0.500 W/kg

Date: 2013/05/29

Ambient Temp. : 24.5 degree.C. Liquid Temp. ; 24.0 degree.C.

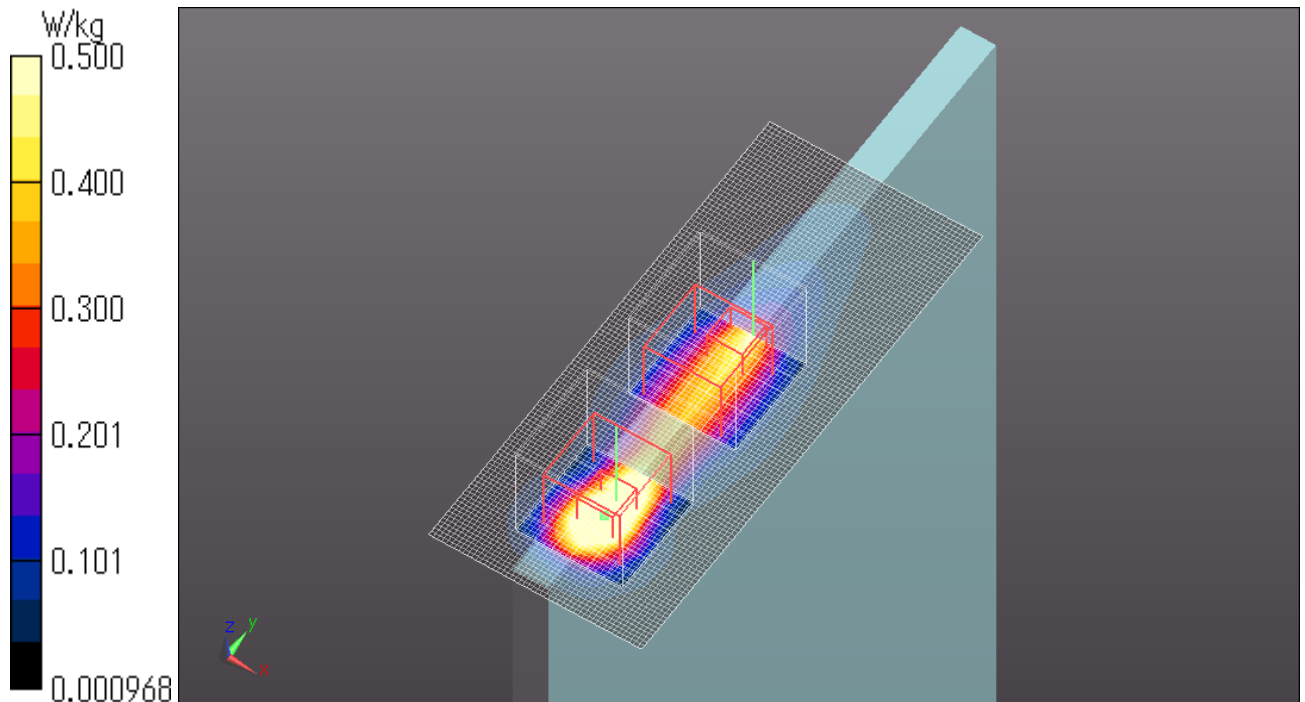

WLAN 11n40 HT8 2437MHz Right side 0mm Ant. Main and Aux

Communication System: UID 0, WLAN 11a/b/g/n ; Communication System Band: WLAN 11b/g/n; Frequency: 2437 MHz; Communication System PAR: 0 dB; PMF: 1.12202e-005
Medium parameters used (interpolated): $f = 2437$ MHz; $\sigma = 1.991$ S/m; $\epsilon_r = 50.808$; $\rho = 1000$ kg/m³
Phantom section: Flat Section
Measurement Standard: DASY5 (IEEE/IEC/ANSI C63.19-2007)
DASY Configuration:
Probe: EX3DV4 - SN3825; ConvF(7.33, 7.33, 7.33); Calibrated: 2012/12/10;
Modulation Compensation:
Sensor-Surface: 2mm (Mechanical Surface Detection), $z = 1.0, 31.0$
Electronics: DAE4 Sn509; Calibrated: 2012/07/13
Phantom: ELI 4.0; Type: QDOVA001BA;
DASY52 52.8.7(1137); SEMCAD X 14.6.10(7164)

Area Scan 2 (51x121x1): Interpolated grid: $dx=1.200$ mm, $dy=1.200$ mm
Maximum value of SAR (interpolated) = 0.826 W/kg

Zoom Scan (7x7x7)/Cube 0: Measurement grid: $dx=5$ mm, $dy=5$ mm, $dz=5$ mm
Reference Value = 21.144 V/m; Power Drift = -0.06 dB
Peak SAR (extrapolated) = 1.33 W/kg
SAR(1 g) = 0.532 W/kg; SAR(10 g) = 0.208 W/kg
Maximum value of SAR (measured) = 0.898 W/kg

Date: 2013/05/29

Ambient Temp. : 24.5 degree.C. Liquid Temp. ; 24.0 degree.C.

