

Toshiba Wireless LAN Card Installation

This sheet provides information on installing the wireless LAN card.



This sheet is for information only. The wireless LAN card must be installed by Toshiba or Toshiba OEM dealers.

Installing the Wireless LAN Card (Tecra 9000)

Before handling the wireless LAN card, discharge static electricity from your body by touching a metal object. Before installing the wireless LAN card, you will first have to remove the battery pack and keyboard. Follow the steps below and refer to the following figures.

1. Turn off the power and disconnect the AC adaptor.
2. Turn the computer upside down.
3. Remove the main battery pack and optional secondary battery if one is installed in the Slim Select Bay. Refer to the computer user's manual: chapter 6 for details on removing the main battery pack and chapter 8 for details on removing the secondary battery.

4. Remove one screw securing the keyboard.

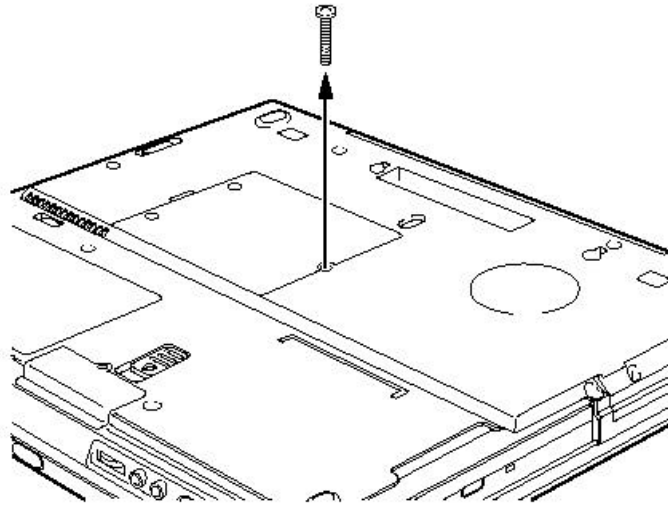

Removing one screw

5. Turn the computer right side up and open the display cover.
6. Insert your fingernail or a thin object under the rim of the keyboard brace and lift out the brace.

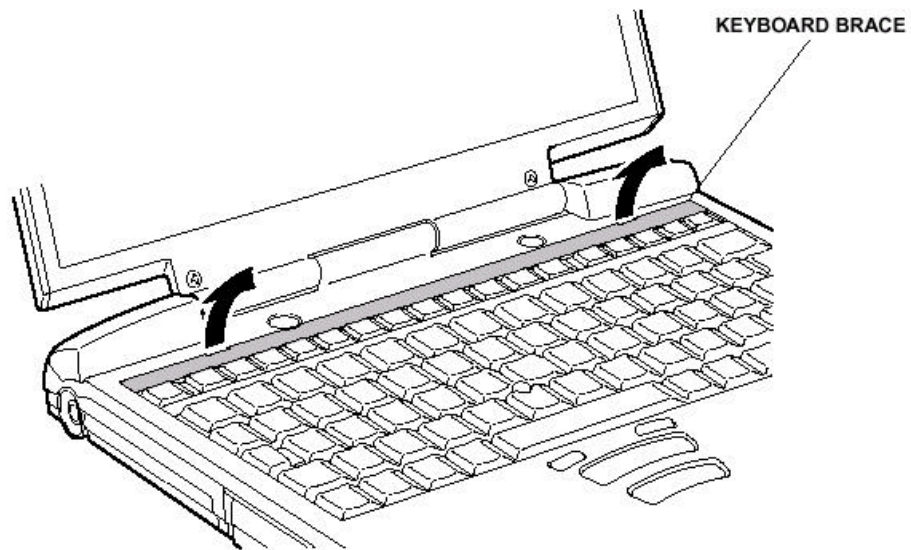

Removing the keyboard brace

7. Remove two screws securing the keyboard.
8. Rotate the keyboard out and lay it on the palm rest.

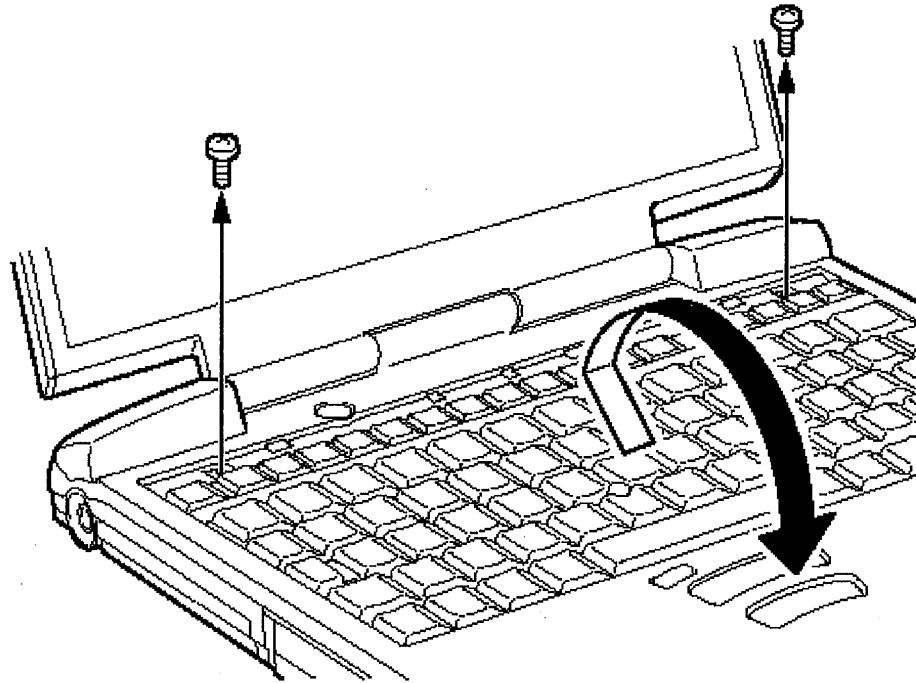

Removing the keyboard

9. Remove one special screw securing the shield plate and lift out the plate.

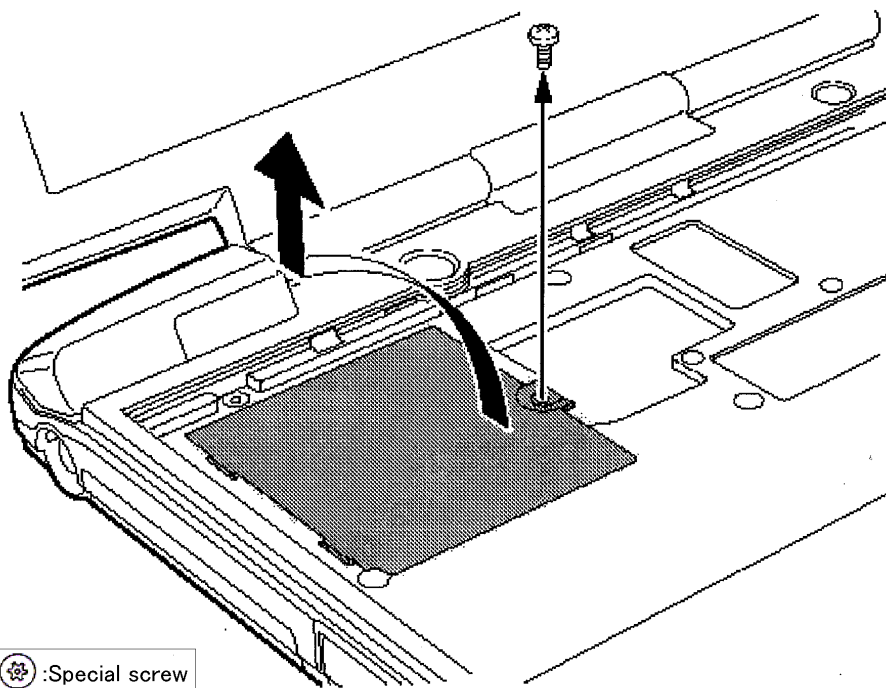

Removing the shield plate

10. Connect the antenna cables to the proper connectors on the wireless LAN card. The cables are colour coded white and black. The corresponding connectors are indicated by the word "Black" or "White" or by the letters "B" or "W."



Use tweezers to align the connectors and press them into place. Be careful not to apply pressure to the ICs on the wireless LAN card.

11. Hold the card at about a 45 degree angle, fit it into the computer's connector and press carefully to ensure firm contact.



Hold the wireless LAN card by the sides only. Do not touch the connector on the card or on the computer. Debris on the connectors may cause access problems.

12. Gently, push the card down until latches on either side engage the card to hold it in place.

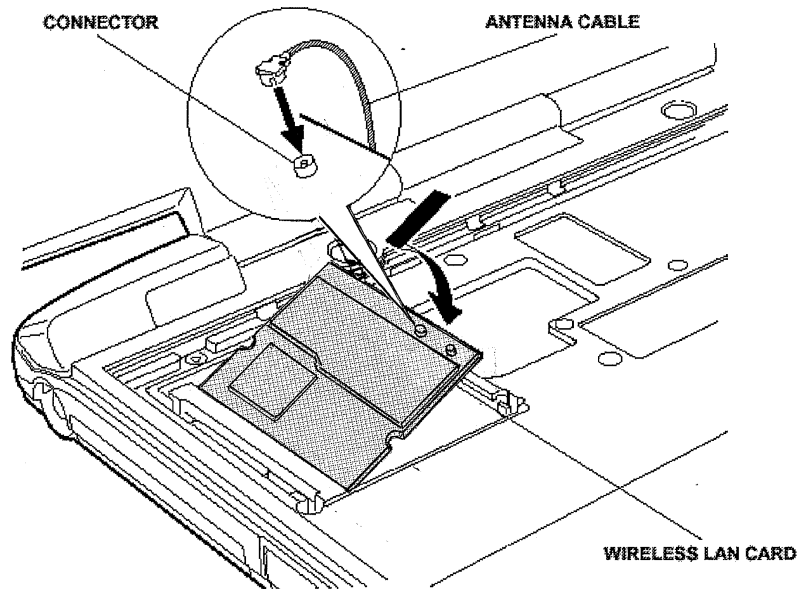

Installing the wireless LAN card (Tecra 9000)

13. Seat the shield plate and secure it with one special screw.
14. Seat the keyboard and secure two screws.
15. Seat the keyboard brace and press to secure latches.
16. Turn the computer upside down and secure one screw.

Installing the wireless LAN Card (Portégé 4000)

Before handling the wireless LAN card, discharge static electricity from your body by touching a metal object. To install the wireless LAN card, follow the steps below and refer to the following figures.

1. Turn off the power and disconnect the AC adaptor.
2. Turn the computer upside down.
3. Remove the main battery pack and optional secondary battery if one is installed in the Slim Select Bay. Refer to the computer user's manual: chapter 6 for details on removing the main battery pack and chapter 8 for details on removing the secondary battery.
4. Remove one six-point black screw and one special screw securing the wireless LAN card slot cover.

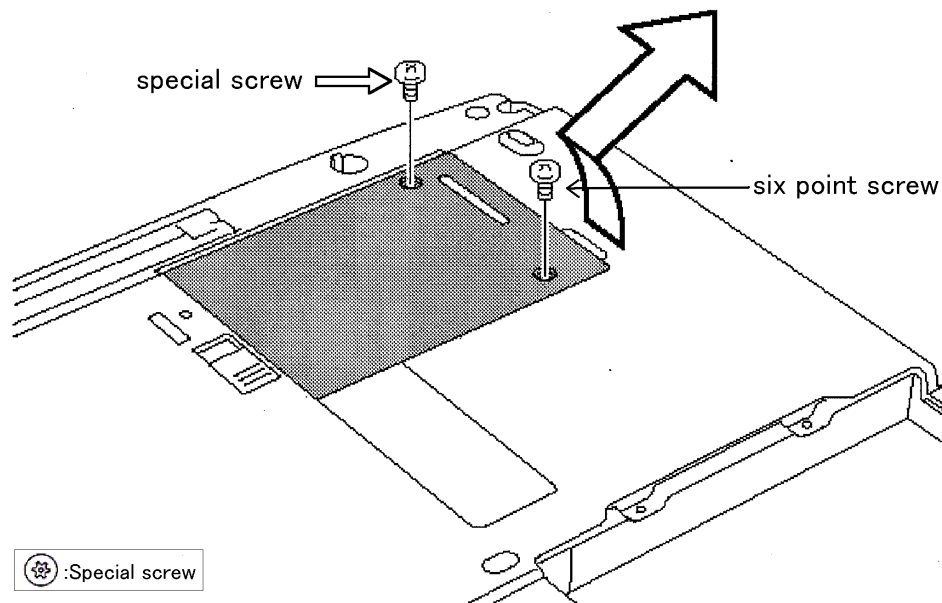

Removing the wireless LAN card slot cover

5. Connect the antenna cables with the appropriate length to the proper connectors on the wireless LAN card.



The short cable will not reach the farther connector.



Use tweezers to align the connectors and press them into place. Be careful not to apply pressure to the ICs on the wireless LAN card.

6. Hold the card at about a 45 degree angle, fit it into the computer's connector and press carefully to ensure firm contact.



Hold the wireless LAN card by the sides only. Do not touch the connector on the card or on the computer. Debris on the connectors may cause access problems.

7. Gently, push the card down until latches on either side engage the card to hold it in place.

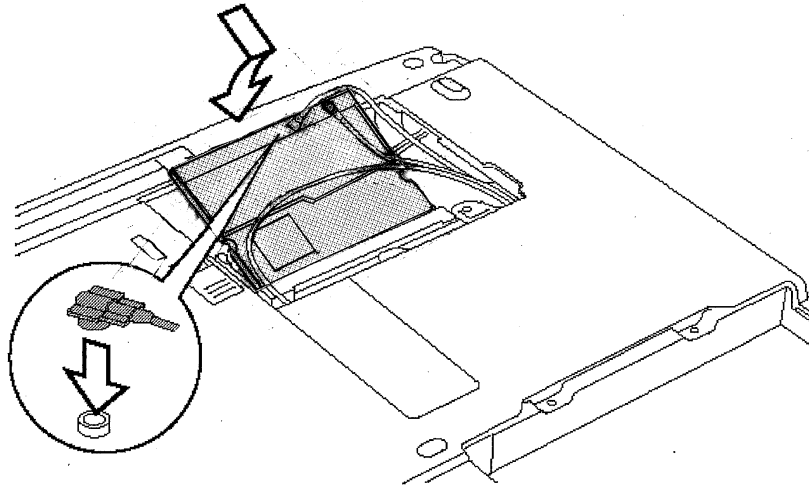

Installing the wireless LAN card

8. Align two tabs on the edge of the wireless LAN card cover with two notches on the wireless LAN card slot and seat the wireless LAN card slot cover.
9. Secure the wireless LAN card slot cover with one six-point screw and one special screw.

Applying labels

The figures below show the locations of labels on the Tecra 9000 and Portégé 4000 series computers. The letters A, B, C and D correspond to labels identified in later illustrations. The applied labels will vary according to your computer's configuration.

Label positions

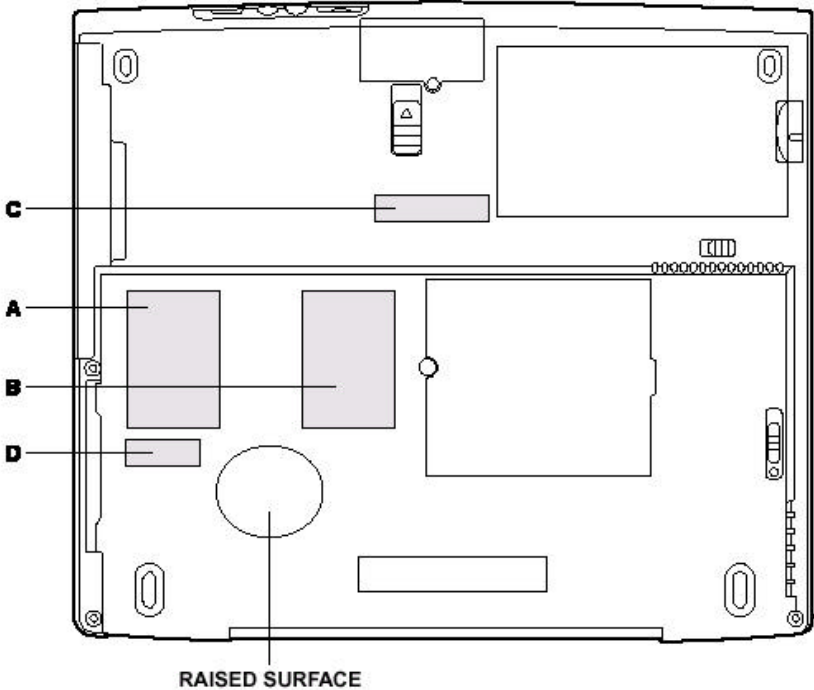

Label positions on the Tecra 9000



There is a round raised surface on the bottom of the Tecra 9000. Do not cover this surface with a label.

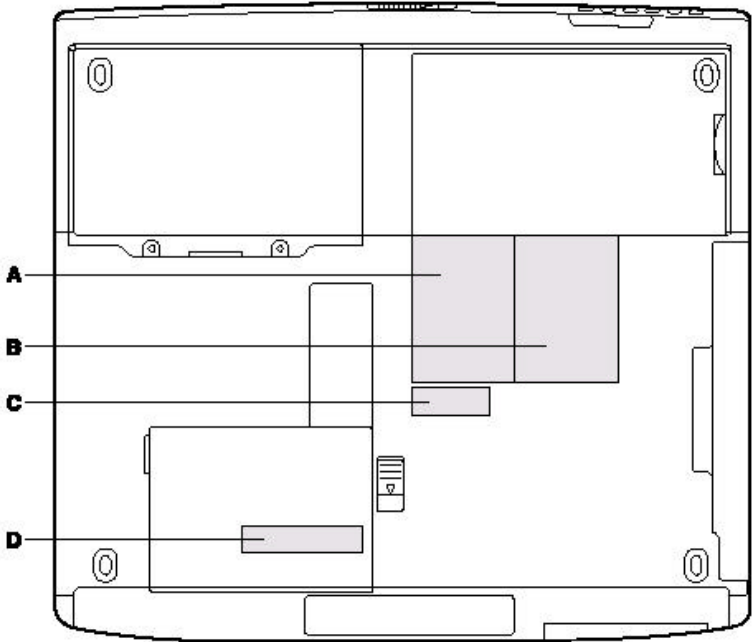

Label positions on the Portégé 4000

New labels

Refer to the figures above and below when you apply new labels.

1. If your computer has the Bluetooth label at position A, apply the Wireless LAN label to position B.

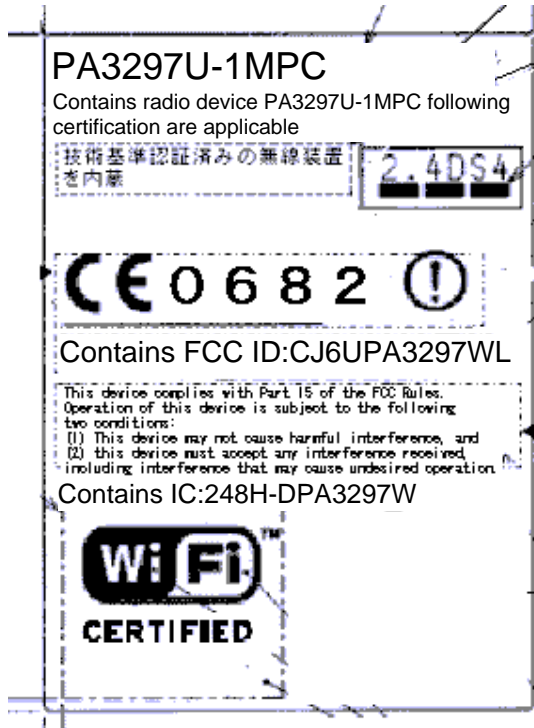

Wireless LAN label



* represents a number. [5] indicates Tecra 9000, and [6] indicates Portégé 4000.

2. Apply to following Wireless LAN label to position C shown in the figure for the Tecra 9000 or the figure for the Portégé 4000.



Apply this Label