



ETS Dr.GenZ Taiwan PS Co., LTD.

FCC Registration No.: 930600

Industry Canada filed test laboratory Reg. No. IC 5679

Accredited Testing Laboratory



A2LA Cert.No.: 2300.01

PTCRB Accredited Type Certification Test House

FCC

TEST - REPORT

FCC RULES PARTS 74 Subpart H, Section 74.861

FCC ID : CINSM-6100

Test report no.:W6M20508-6114-C-1

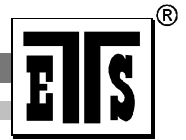

Registration number: W6M20508-6114-C-1
 FCC ID: CINSM-6100

TABLE OF CONTENTS

1	GENERAL INFORMATION	3
1.1	NOTES	3
1.2	TESTING LABORATORY	4
1.2.1	<i>Location</i>	4
1.2.2	<i>Details of accreditation status</i>	4
1.3	DETAILS OF APPROVAL HOLDER	4
1.4	APPLICATION DETAILS	5
1.5	GENERAL INFORMATION OF TEST ITEM	5
1.6	TEST STANDARDS	6
2	TECHNICAL TEST	6
2.1	SUMMARY OF TEST RESULTS	6
2.2	TEST ENVIRONMENT	6
2.3	TEST EQUIPMENT LIST	7
2.4	GENERAL TEST PROCEDURE	10
3	TEST RESULTS (ENCLOSURE).....	11
4	RF POWER OUTPUT (CONDUCTED) , FCC 2.1046 (A) ; 74.861 (E).....	12
4.1	TEST PROCEDURE	12
4.2	TEST RESULTS.....	12
5	RADIATED POWER	13
5.1	TEST PROCEDURE.....	13
5.2	TEST RESULTS	14
6	MODULATION DEVIATION , FCC 2.1047 (B) ; 74.861(E).....	15
6.1	TEST PROCEDURE	15
6.2	TEST RESULTS	15
7	AUDIO FREQUENCY RESPONSE , FCC 2.1047 (A).....	16
7.1	TEST PROCEDURE	16
7.2	TEST RESULTS	16
8	OCCUPIED BANDWIDTH/EMISSION MASK, FCC 2.1049 (C) ; 74.861 (E)(5).....	17
8.1	TEST PROCEDURE	17
8.2	TEST RESULTS.....	17
9	SPURIOUS EMISSIONS AT ANTENNA TERMINALS FCC2.1051 ; 74.861 (E).....	18
9.1	TEST PROCEDURE	18
9.2	TEST RESULTS.....	18
9.3	LIMIT	19
10	RADIATED SPURIOUS EMISSION , FCC 2.1053 ; 74.861 (E)	20
10.1	TEST PROCEDURE	20



Registration number: W6M20508-6114-C-1
 FCC ID: CINSM-6100

10.2	TEST RESULTS.....	20
10.3	EXPLANATION OF TEST RESULT	22
10.4	LIMITS.....	22
11	LINE CONDUCTED EMISSION , FCC 15.207	23
11.1	TEST PROCEDURE	23
11.2	TEST RESULTS.....	23
12	FREQUENCY STABILITY VS. TEMPERATURE , FCC 2.1055 , 74.861 (E).....	24
12.1	TEST PROCEDURE	24
12.2	TEST RESULTS.....	24
13	FREQUENCY STABILITY VS. VOLTAGE , FCC 2.1055 (D) ; 74.861 (E).....	26
13.1	TEST PROCEDURE	26
13.2	TEST RESULTS.....	26
APPENDIX	27
	APPENDIX A.....	28
	APPENDIX B	29
	APPENDIX C	30
	APPENDIX D.....	31
	APPENDIX E	32
	APPENDIX F	33
	APPENDIX G.....	34
	APPENDIX H.....	35
	APPENDIX I	36



Registration number: W6M20508-6114-C-1
 FCC ID: CINSM-6100

1 General Information

1.1 Notes

The purpose of conformity testing is to increase the probability of adherence to the essential requirements or conformity specifications, as appropriate.

The complexity of the technical specifications, however, means that full and thorough testing is impractical for both technical and economic reasons.

Furthermore, there is no guarantee that a test sample which has Passed all the relevant tests conforms to a specification.

Neither is there any guarantee that such a test sample will interwork with other genuinely open systems.

The existence of the tests nevertheless provides the confidence that the test sample possesses the qualities as maintained and that its performance generally conforms to representative cases of communications equipment.

The test results of this test report relate exclusively to the item tested as specified in 1.5.

The test report may only be reproduced or published in full.

Reproduction or publication of extracts from the report requires the prior written approval of the ETS DR. GENZ TAIWAN PS CO., LTD.

Tester:

07.10.2005		Jay Chaing	<i>Jay Chaing</i>
<hr/>			
Date	ETS-Lab.	Name	Signature

Technical responsibility for area of testing:

07.10.2005		Steven Chung	<i>Steven Chung</i>
<hr/>			
Date	ETS	Name	Signature

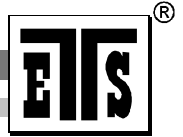

Registration number: W6M20508-6114-C-1
FCC ID: CINSM-6100

1.2 Testing laboratory

1.2.1 Location

OATS
No.5-1, Shuang Sing Village,
LiShuei Rd., Wanli Township,
Taipei County 207, Taiwan (R.O.C.)

Company
ETS DR. GENZ TAIWAN PS CO., LTD.
6F, NO. 58, LANE 188, RUEY-KUANG RD.
NEIHU, TAIPEI 114, TAIWAN R.O.C.
Tel : 886-2-66068877
Fax : 886-2-66068879

1.2.2 Details of accreditation status

Accredited testing laboratory

A2LA-registration number: 2300.01

FCC filed test laboratory Reg. No. 930600

Industry Canada filed test laboratory Reg. No. IC 5679

PTRCB Accredited Type Certification Test House

1.3 Details of approval holder

Name : Chiayo Electronics Co., Ltd.
Street : No.88, Chung Hsiao Street 2
Town : Chiayi
Country : Taiwan, R.O.C.
Telephone : +886-5-271-1000
Fax : +886-5-276-7611
Contact : Mrs. Teresa Hung
Telephone : +886-5-271-1000



Registration number: W6M20508-6114-C-1
 FCC ID: CINSM-6100

1.4 Application details

Date of receipt of application : 19.08.2005
 Date of receipt of test sample : 07.09.2005
 Date of test : 07.09.2005 to 06.10.2005

1.5 General information of Test item

Type of test item : Wireless Microphone
 Model Number : SM-6100
 Serial number : without
 Photos : see Annex

Technical data

Frequency band :

Frequency(MHz)	TV Band	Used Band
26.100-26.480	<input type="checkbox"/>	<input type="checkbox"/>
54.000-72.000	<input checked="" type="checkbox"/>	<input type="checkbox"/>
76.000-88.000	<input checked="" type="checkbox"/>	<input type="checkbox"/>
161.625-161.775	<input type="checkbox"/>	<input type="checkbox"/>
174.000-216.000	<input checked="" type="checkbox"/>	<input type="checkbox"/>
450.000-451.000	<input type="checkbox"/>	<input type="checkbox"/>
455.000-456.000	<input type="checkbox"/>	<input type="checkbox"/>
470.000-488.000	<input type="checkbox"/>	<input type="checkbox"/>
488.000-494.000	<input checked="" type="checkbox"/>	<input type="checkbox"/>
494.000-608.000	<input checked="" type="checkbox"/>	<input type="checkbox"/>
614.000-806.000	<input checked="" type="checkbox"/>	<input checked="" type="checkbox"/>
944.000-952.000	<input type="checkbox"/>	<input type="checkbox"/>

Frequency (ch A) : 614.5 MHz
 Frequency (ch B) : 710 MHz
 Frequency (ch C) : 806 MHz

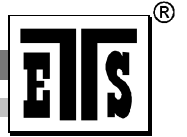

Registration number: W6M20508-6114-C-1
FCC ID: CINSM-6100

Antenna Type : 1/4 wave , whip antenna
Antenna Gain : 0 dBi
Power supply : 3 VDC (1.5V Battery x 2)
Operation modes : Simplex

Manufacturer:
(if applicable)

Name : ./.
Street : ./.
Town : ./.
Country : ./.

1.6 Test standards

Technical standard : FCC Part 74 Subpart H , section 74.861
Additional information : none

2 Technical test

2.1 Summary of test results

No deviations from the technical specification(s) were ascertained in the course of the tests performed.

or

The deviations as specified in 2.5 were ascertained in the course of the tests performed.

2.2 Test environment

Temperature : 23 °C
Relative humidity content : 20 ... 75 %
Air pressure : 86-103 KPa

Registration number: W6M20508-6114-C-1
FCC ID: CINSM-6100

2.3 Test Equipment List

No.	Test equipment	Type	Serial No.	Manufacturer	Next Cal. Date
ETSTW-CE 001	EMI TEST RECEIVER	ESHS10	842121/013	R&S	2005/11/8
ETSTW-CE 002	PREREULATOR MODE DC POWER SUPPLY				
ETSTW-CE 003	AC POWER SOURCE	APS-9102	D161137	GW	
ETSTW-CE 004	ZWEILEITER-V-NETZNACHBILDUNG TWO-LINE V-NETWORK	ESH3-Z5	840731/011	R&S	2006/11/8
ETSTW-CE 005	Line-Impedance Stabilisation Network	NNBM 8126D	137	Schwarzbeck	2006/11/3
ETSTW-CE 006	IMPULS-BEGRENZER PULSE LIMITER	ESH3-Z2	100226	R&S	2006/11/10
ETSTW-CE 007	SPECTRUM ANALYZER 5GHz	FSB	849670/001	R&S	
ETSTW-CE 008	ABSORBING CLAMP	MDS 21	3469	ABSORPTIONS- MESSWANDLER- ZANGE	2006/11/4
ETSTW-CE 009	TEMP.&HUMIDITY CHAMBER	GTH-225-40-1P-U	MAA0305-009	GIANT FORCE	2005/5/10
ETSTW-CE 010	Comb Generator-conducted			ETS	
ETSTW-CE 011	Power Line Conducted Emission Only			ETS	
ETSTW-CE 012	Dual-Phase-V-Network	NNB-2/16Z	03/10201	Telemeter	2006/4/11
ETSTW-CS 001	SIGNAL GENERATOR	SMX	849254/003	R&S	2005/10/31
ETSTW-CS 002	COUPLING AND DECOUPLING NETWORK	CDN S751	19263	SCHAFFNER	2006/11/3
ETSTW-CS 003	COUPLING AND DECOUPLING NETWORK	CDN T400	19820	SCHAFFNER	2006/11/3
ETSTW-CS 004	COUPLING AND DECOUPLING NETWORK	CDN M016	20053	SCHAFFNER	2006/11/3
ETSTW-CS 005	RF Power Amplifier	100A250A	306547	AR	2005/11/3
ETSTW-CS 006	Terminal 50Ω Load	50T-116 M		JFW	
ETSTW-CS 007	Terminal 50Ω Load	50T-116 F		JFW	
ETSTW-CS 008	6 dB Attenuator	HFP-5100-3/06 N M/F	2010876106		
ETSTW-RE 001	Controller	CD 1000	C01000/154/867 /004/L	Heinrich Deisel	
ETSTW-RE 002	Function Generator	33220A	MY43004982	Agilent	2005/11/3
ETSTW-RE 003	EMI TEST RECEIVER	ESI	831438/001	R&S	2005/11/16
ETSTW-RE 004	EMI TEST RECEIVER	ESI	831459/012	R&S	2005/11/9
ETSTW-RE 005	EMI TEST RECEIVER	ESVS10	843207/020	R&S	2005/11/1
ETSTW-RE 008	Controller	HD100	C0100-L/047/ 6670703/L	Heinrich Deisel	
ETSTW-RE 009	Controller	HD100	100/341	Heinrich Deisel	
ETSTW-RE 010	PROGRAMMABLE LINEAR POWER SUPPLY	LPS-305	30503070181	MOTECH	
ETSTW-RE 011	PROGRAMMABLE LINEAR POWER SUPPLY	LPS-305	30503070165	MOTECH	
ETSTW-RE 012	TUNABLE BANDREJECT FILTER	D.C 0309	146	K&L	
ETSTW-RE 013	TUNABLE BANDREJECT FILTER	D.C 0036	397	K&L	
ETSTW-RE 014	DUAL TRACKING WITH 5V FIXED	GPC-3030D		GW	
ETSTW-RE 015	ANTENNA	HK116	841489/003	R&S	
ETSTW-RE 016	ANTENNA	HL223	848953/006	R&S	
ETSTW-RE 017	ANTENNA	HL025	352886/001	R&S	
ETSTW-RE 018	ANTENNA	AT4560	27212	AR	2006/11/7
ETSTW-RE 019	ANTENNA , HORN	22240-25	121074	FM	

Registration number: W6M20508-6114-C-1
FCC ID: CINSM-6100

ETSTW-RE 020	MICROWAVE HORN ANTENNA	AT4002A	306915	AR	
ETSTW-RE 021	SWEEP GENERATOR	SWM05	835130/010	R&S	2005/11/10
ETSTW-RE 022	AMPLIFIER	8447D	2944A09837	Agilent	2005/11/1
ETSTW-RE 023	Shielded room	SR 1		Frankonia	
ETSTW-RE 024	Anechoic Chamber	CHC 1		Frankonia	
ETSTW-RE 025	Anechoic Chamber	CHC 2		Frankonia	
ETSTW-RE 026	Open Area Test Site	10m		ETS	
ETSTW-RE 027	Passive Loop Antenna	6512	34563	EMCO	2006/6/29
ETSTW-RE 028	Log-Periodic DipoleArray Antenna	3148	34429	EMCO	2006/6/14
ETSTW-RE 029	Biconical Antenna	3109	33524	EMCO	2006/6/16
ETSTW-RE 030	Double-Ridged Waveguide Horn Antenna	3117	35224	EMCO	2006/5/4
ETSTW-RE 031	Comb Generator-radiated			ETS	
ETSTW-RE 032	Millivoltmeter	URV 55	849086/013	R&S	2005/11/17
ETSTW-RE 033	4CH 1GHz 5GS/s DSO	WAVERUNNER 6100A	LCRY0604P14508	LeCory	
ETSTW-RE 034	Power Sensor	URV5-Z4	839313/006	R&S	2005/11/17
ETSTW-RE 035	1.5GHz Active Voltage Probe	HFP1500	2332	LeCory	
ETSTW-RE 036	100MHz High Voltage Diff Probe	ADP305	3305	LeCory	
ETSTW-RE 037	Log-Periodic DipoleArray Antenna	3148	00034546	EMCO	2006/11/17
ETSTW-RE 038	Log-Periodic DipoleArray Antenna	3148	00034547	EMCO	2006/11/17
ETSTW-RE 039	Biconical Antenna	3110B	41760	EMCO	2006/11/17
ETSTW-RE 040	Biconical Antenna	3110B	41761	EMCO	2006/11/17
ETSTW-RE 041	Anechoic Chamber	CHC 3		Frankonia	
ETSTW-RE 042	ANTENNA	HK116	100172	R&S	2007/1/13
ETSTW-RE 043	ANTENNA	HL223	100166	R&S	2006/4/15
ETSTW-RE 044	ANTENNA	HL050	100094	R&S	
ETSTW-RE 048	Triple Loop Antenna	HXYZ 9170	HXYZ 9170-134	Schwarzbeck	2006/3/21
ETSTW-RE 049	TRILOG Super Broadband test Antenna	VULB 9160	9160-3185	Schwarzbeck	2007/5/18
ETSTW-EMI 001	HARMONICS 1000	HAR1000-1P	93	EMC-PARTNER	2005/11/17
ETSTW-EMS 001	Clamp BASELSTRASSE 160 CH-4242 LAUFEN	CN-EFT1000	354	EMC-PARTNER	2005/11/1
ETSTW-EMS 002	Frequency Converter	YF-6020	0308014		
ETSTW-EMS 003	EMC Immunity Test System	TRA2000IN6	579	EMC-PARTNER	2005/11/1
ETSTW-EMS 004	ESD generator minizap	ESD2000	016	EMC-PARTNER	2005/11/1
ETSTW-EMS 005	Attenuator (50Ω)	VERI50	051	EMC-PARTNER	2006/8/30
ETSTW-EMS 006	Attenuator (1 KΩ)	VERI1K	019	EMC-PARTNER	2006/10/20
ETSTW-EMS 007	20GΩ Divider	ESD-VERI-V	021	EMC-PARTNER	2006/3/16
ETSTW-RS 001	14" COLOR VIDEO MONITOR	TP-1480HR	P009799	TOPICA	
ETSTW-RS 002	14" COLOR VIDEO MONITOR	TP-1480HR	P009814	TOPICA	
ETSTW-RS 003	RF Power Amplifier	30S1G3	306933	AR	
ETSTW-RS 004	RF Power Amplifier	150W1000	307009	AR	2005/11/18
ETSTW-RS 005	Electric Field Probe Type 8.3	EMR-20	BN 2244/20	GW	2005/9/3
ETSTW-RS 006	SIGNAL GENERATOR	SML03	101551	R&S	2005/11/15

Registration number: W6M20508-6114-C-1
FCC ID: CINSM-6100

ETSTW-RS 007	AUDIO ANALYZER	UPA3	843458/029	R&S	2005/11/15
ETSTW-EMS 008	Safety Test Solutions	ELT-400	E-0039	Narda	2006/1/3
ETSTW-EMS 009	Magnetic Field Antenna	MF1000-1	104	EMC-PARTNER	2006/12/2
ETSTW-GSM 01	SIM Simulator	IT3	B2004-50106	ORGA	
ETSTW-GSM 02	Universal Radio Communication Tester	CMU 200	103489	R&S	
ETSTW-GSM 03	Agilent 8960 Test Set 1	E5515C	GB44052675	Agilent	2006/7/13
ETSTW-GSM 04	Agilent 8960 Test Set 2	E5515C	GB44052665	Agilent	2006/7/13
ETSTW-GSM 05	Agilent 8960 Test Set 3	E5515C	GB44052652	Agilent	2006/7/16
ETSTW-GSM 06	Agilent 8960 Test Set 4	E5515C	GB44052684	Agilent	2006/7/15
ETSTW-GSM 07	Agilent 8960 Test Set 5	E5515C	GB44052658	Agilent	2006/7/13
ETSTW-GSM 08	Agilent 8960 Test Set 6	E5515C	GB44052666	Agilent	2006/7/15
ETSTW-GSM 09	Controler PC	Dell GX 270	700F61J	Dell	
ETSTW-GSM 10	Combiner Wessex / Anite	B4605/100	053	Wessex / Anite	2006/7/13
ETSTW-GSM 11	GSM 850,900,1800,1900 Test system	TS8950G		R&S	2005/10/31
ETSTW-GSM 12	Acoustical Calibrator	4231	2463874	Brüel&Kjær	2005/11/17
ETSTW-GSM 13	Conditioning Amplifier	2690--0S2	2437856	Brüel&Kjær	
ETSTW-GSM 14	Telephone Test Head	4602B	2465324	Brüel&Kjær	
ETSTW-GSM 15	Mouth Simulator	4227	2462516	Brüel&Kjær	
ETSTW-GSM 16	TEMP.&HUMIDITY CHAMBER	GTH-120-40-1P-U	MAA0501002	GIANT FORCE	2005/12/29
ETSTW-GSM 17	ANTENNT COPLER	CMU-Z10	100988	R&S	
ETSTW-GSM 18	AUDIO ANALYZER	UPL16	100173	R&S	2005/9/23
ETSTW-GSM 19	Band Reject Filter	WRCTF824/ 849-822/851-40 /12+9SS	3	WI	
ETSTW-GSM 20	Band Reject Filter	WRCD1747/1748- 1743/1752-32/5SS	1	WI	
ETSTW-GSM 21	Band Reject Filter	WRCD1879.5/ 1880.5- 1875.5/ 1884.5-32/5SS	3	WI	
ETSTW-GSM 22	Band Reject Filter	WRCT901.9/903.1 - 904.25-50/8SS	1	WI	

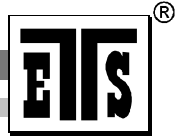

Registration number: W6M20508-6114-C-1
FCC ID: CINSM-6100

2.4 General Test Procedure

POWER LINE CONDUCTED INTERFERENCE: The procedure used was ANSI STANDARD C63.4-2003 using a 50 μ H LISN (if necessary). Both lines were observed. The bandwidth of the spectrum analyzer was 10 kHz with an appropriate sweep speed.

RADIATION INTERFERENCE: The test procedure used was according to ANSI STANDARD C63.4-2003 employing a spectrum analyzer. For investigated frequency is equal to or below 1GHz, the RBW and VBW of the spectrum analyzer was 100 kHz and 100kHz respectively with an appropriate sweep speed. For investigated frequency is above 1GHz, both of RBW and VBW of the spectrum analyzer were 1 MHz with an appropriate sweep speed. The analyzer was calibrated in dB above a microvolt at the output of the antenna. The ambient temperature of the UUT was 23°C with a humidity of 40 %.

The table used for radiated measurements is capable of continuous rotation. The spectrum was scanned from 30 MHz to the frequency specified as follows:

- (1) If the intentional radiator operates below 10 GHz: to the tenth harmonic of the highest fundamental frequency or to 40 GHz, whichever is lower.
- (2) If the intentional radiator operates at or above 10 GHz and below 30 GHz: to the fifth harmonic of the highest fundamental frequency or to 100 GHz, whichever is lower.
- (3) If the intentional radiator operates at or above 30 GHz: to the fifth harmonic of the highest fundamental frequency or to 200 GHz, whichever is lower, unless specified otherwise elsewhere in the rules.
- (4) If the intentional radiator contains a digital device, regardless of whether this digital device controls the functions of the intentional radiator or the digital device is used for additional control or function purposes other than to enable the operation of the intentional radiator, the frequency range shall be investigated up to the range specified in paragraphs (a)(1)-(a)(3) of this section or the range applicable to the digital device, as shown in paragraph (b)(1) of this Section, whichever is the higher frequency range of investigation.

For hand-held devices, an exploratory test was performed with three (3) orthogonal planes to determine the highest emissions.

Measurements were made by at the registered open field test site located at The Registration Number:

When an emission was found, the table was rotated to produce the maximum signal strength. At this point, the antenna was raised and lowered from 1m to 4m. The antenna was placed in both the horizontal and vertical planes.

ANTENNA & GROUND:

This unit uses 1/4 wave , whip antenna. (see photo).



Registration number: W6M20508-6114-C-1
 FCC ID: CINSM-6100

3 Test results (enclosure)

TEST CASE	Para. Number	Required	Test passed	Test failed
RF Power Output	2.1046 (a); 74.861 (e)(1)	<input checked="" type="checkbox"/>	<input checked="" type="checkbox"/>	<input type="checkbox"/>
Modulation Deviation	2.1047 (b); 74.861 (e)(2)	<input checked="" type="checkbox"/>	<input checked="" type="checkbox"/>	<input type="checkbox"/>
Audio Frequency Response	2.1047 (a)	<input checked="" type="checkbox"/>	<input checked="" type="checkbox"/>	<input type="checkbox"/>
Occupied Bandwidth / Emission Mask	2.1049 (c)(1); 74.861 (e)(5)	<input checked="" type="checkbox"/>	<input checked="" type="checkbox"/>	<input type="checkbox"/>
Spurious Emissions at Antenna Terminals	2.1051 74.861(e)(6)	<input checked="" type="checkbox"/>	<input checked="" type="checkbox"/>	<input type="checkbox"/>
Radiated Spurious Emission	2.1053 74.861(e)(6)	<input checked="" type="checkbox"/>	<input checked="" type="checkbox"/>	<input type="checkbox"/>
Line Conducted Emissions	15.207	<input type="checkbox"/>	<input type="checkbox"/>	<input type="checkbox"/>
Frequency Stability vs. Temperature	2.1055 (b); 74.861(e)(4)	<input checked="" type="checkbox"/>	<input checked="" type="checkbox"/>	<input type="checkbox"/>
Frequency Stability vs. Voltage	2.1055 (a)(1); 74.861 (e)(4)	<input checked="" type="checkbox"/>	<input checked="" type="checkbox"/>	<input type="checkbox"/>

The follows is intended to leave blank.

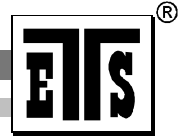

Registration number: W6M20508-6114-C-1
 FCC ID: CINSM-6100

4 RF Power Output (conducted) , FCC 2.1046 (a) ; 74.861 (e)

4.1 Test procedure

This transmitter output was connected to a calibrated coaxial attenuator, the other end of which was connected to a spectrum analyzer. Transmitter output was derived with the spectrum analyzer in dBm.

The power output at the transmitter antenna port was determined by assign the value of the attenuator to the spectrum analyzer reading.

An HP power meter was also used to measure the RF power.

Tests were performed with an unmodulated carrier at three frequencies (low , middle and high channels) and on all power levels , which can be set-up on the transmitters.

4.2 Test Results

Frequency Channel	Peak Output Power (dBm)
614 MHz	3.00
710 MHz	1.03
806 MHz	-4.08

Limits:

LPAS operating in TV bands	
Frequency [MHz]	Conducted output power [mW]
54 – 72 76 – 88 174 - 216	50 (17 dBm)
470 – 608 614 - 806	250 (24 dBm)

LPAS operating in other than TV bands	
Conducted power [W]	
	1

Comment : see attached diagrams.

Registration number: W6M20508-6114-C-1
FCC ID: CINSM-6100

5 Radiated Power

5.1 Test Procedure

The EUT was positioned on a non-conductive turntable, 0.8m above the ground on an open test site.

The radiated emission at the fundamental frequency was measured at 3m distance with a test antenna and spectrum analyzer.

Worst case emission was recorded with the rotation of the turntable and the raising and lowering of the test antenna.

Substitution RF power Measurement at ETS Taiwan

General :

The applied substitution method follows ANSI/TIA/EIA-603, ANSI/TIA/EIA-102.CAAA or the appropriate ETSI rules respectively.

The actual signal generated by the EUT can be determined by means of a substitution measurement in which a known signal source replaces the device to be measured.

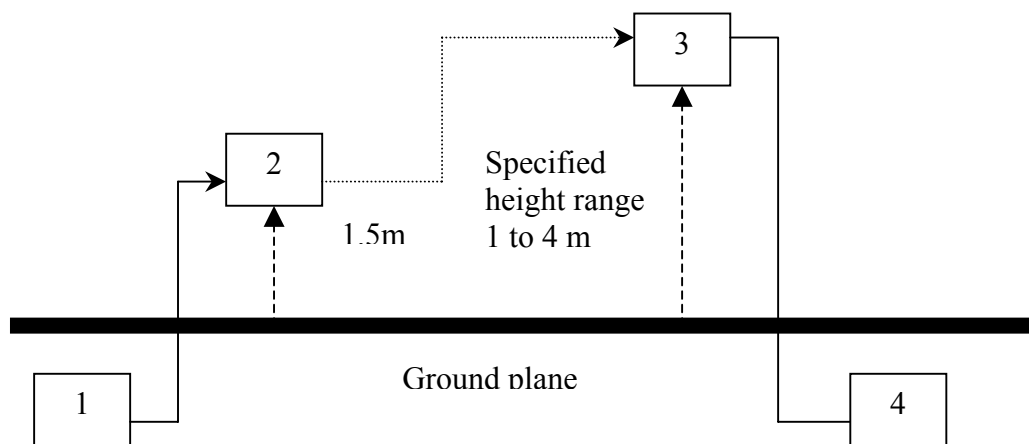

- 1) Signal generator ;
- 2) Substitution antenna ;
- 3) Test antenna ;
- 4) Spectrum analyzer or selective voltmeter.

The substitution antenna replaces the transmitter antenna at the same position and in vertical polarization. The frequency of the signal generator shall be adjusted to the measurement frequency.

The test antenna shall be raised or lowered, if necessary, to ensure that the maximum signal is still received. The input signal to the substitution antenna shall be adjusted in level until an equal or a known related level to that detected from the transmitter is obtained in the measurement receiver.

If a fully anechoic chamber is used as test site in order to provide free space conditions there is no need to change the height of the antenna.

Registration number: W6M20508-6114-C-1
FCC ID: CINSM-6100

The measurement will be repeated in horizontal position.

Calibration :

In order to make this kind of measurement more effective and to avoid subjective measurement faults ETS has installed automatic computer controlled measurement procedures.

With the above described substitution method a test site is calibrated over the full frequency range which is used in suitable frequency steps. For a certain power level on the substitution antenna the received power over the whole frequency range is documented. All necessary antenna gains, cable losses, filter losses and amplifications of preamplifiers are taken in consideration. The summary of this calibration measurement performs a transducer factor that is related to the considered test site and a certain measurement distance. Differences of the radiated power levels of different test samples are determined by internal attenuation of measurement receiver . The proper function of such test site will be maintained by short term plausibility checks and periodical re-calibration.

Testing :

Now the test sample will be putted on the table at the defined position and the radiated power will be receiver and documented by the measurement receiver.

On test sites with ground plane the measurement antenna will be lowered and raised to maximum values at significant frequencies.

For peak power measurements the sample is turned by the turntable over 360 degree in order to find the direction with the maximum radiation or to document the max reading with the MAXHOLD function during the rotation.

5.2 Test results

Radiated Power (dBm)	
614 MHz	3.81
710 MHz	1.14
806 MHz	-3.13

Comment : see attached diagrams.

Registration number: W6M20508-6114-C-1
FCC ID: CINSM-6100

6 Modulation Deviation , FCC 2.1047 (b) ; 74.861(e)

6.1 Test procedure

Modulation limiting is the transmitter circuit's ability to limit the transmitter from producing deviations in excess of rated system deviation.

The audio signal generator is connected to the audio input of the EUT with its full rating. The modulation response is measured at certain modulation frequencies, related to 1000Hz reference signal. Tests are performed for positive and negative modulation.

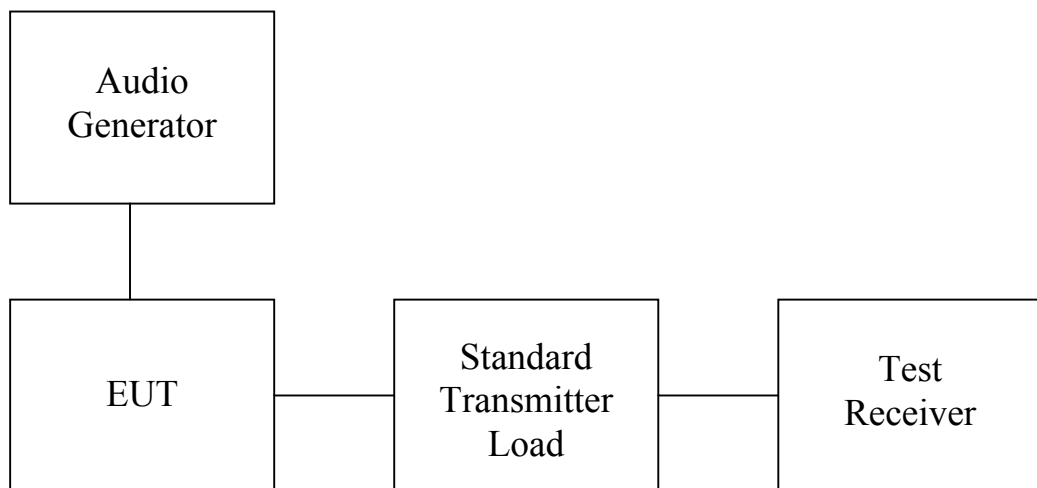

6.2 Test results

Limits : ± 75 kHz

Comment : see attached diagrams.

Registration number: W6M20508-6114-C-1
FCC ID: CINSM-6100

7 Audio frequency response , FCC 2.1047 (a)

7.1 Test procedure

The audio frequency response is the degree of closeness to which the frequency deviation of the transmitter follows a prescribed characteristic.

The frequency response of the audio modulation part is measured over a frequency range of 100 Hz to 5000Hz.

For 1000Hz tone reference signal the audio generator level is adjusted to get 20% of the rated system deviation.

The deviations obtained over the frequency range from 100Hz to 5000Hz are recorded and compared with the reference deviation as follows :

$$\text{Audio Frequency Response} = 20 \log [\text{DEV}_{\text{Freq}} / \text{DEV}_{\text{ref}}].$$

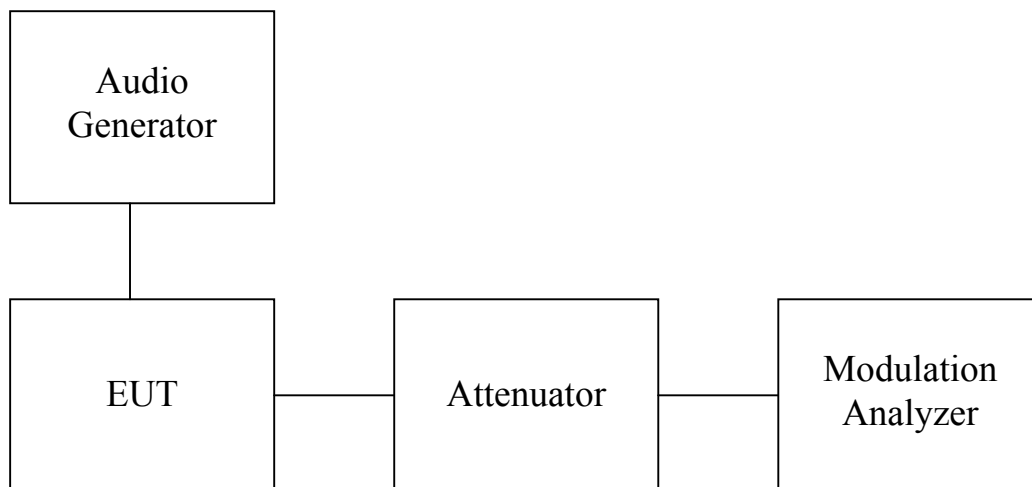

7.2 Test results

Comment : see attached diagrams.

Registration number: W6M20508-6114-C-1
FCC ID: CINSM-6100

8 Occupied Bandwidth/Emission Mask, FCC 2.1049 (c) ; 74.861 (e)(5)

The occupied bandwidth, that is the frequency bandwidth such that, below its lower and above its upper frequency limits, the mean powers radiated are each equal to 0.5 percent of the total mean power.

Near the carrier an Emission Mask is defined by the standard.

8.1 Test procedure

The RF output of the transceiver was connected to the input of the spectrum analyzer through sufficient attenuation.

Occupied Bandwidth was measured with a occupied bandwidth function of the analyzer.

The near the carrier emissions are measured by normal power measurement function of the analyzer.

8.2 Test Results

1000 Hz Modulation

Occupied Channel Bandwidth (kHz)	
Channel A	54.52104208
Channel B	76.52505010
Channel C	54.52104208

2500 Hz Modulation

Occupied Channel Bandwidth (kHz)	
Channel A	65.52304609
Channel B	81.90380762
Channel C	65.76753507

Comment : see attached diagram in appendix.

For near the carrier emissions see attached diagrams.

Registration number: W6M20508-6114-C-1
FCC ID: CINSM-6100

9 Spurious Emissions at Antenna Terminals FCC2.1051 ; 74.861 (e)

9.1 Test procedure

This transmitter output was connected to a calibrated coaxial attenuator, the other end of which was connected to a spectrum analyzer. Transmitter output was derived with the spectrum analyzer in dBm.

The Spurious Emissions at Antenna Terminals was measured by the spectrum analyzer with a suitable notch filter and high-pass filter.

Tests were performed with an unmodulated carrier at three frequencies (low , middle and high channels) and on all power levels , which can be set-up on the transmitters.

9.2 Test Results

Summary table with conducted data of the test plots for Carrier Test Frequency 614.5 MHz

Frequency Marker Indication [MHz]	Indication Power Level [dBm]	Compliance Limit [dBm]	Margin
614.53046092	0.36	Carrier	
200.00000000	-65.89	-13	52.89
1841.68337	-68.99	-13	55.99
6925.85170	-51.62	-13	38.62

Summary table with conducted data of the test plots for Carrier Test Frequency 710 MHz

Frequency Marker Indication [MHz]	Indication Power Level [dBm]	Compliance Limit [dBm]	Margin
710.20040080	-2.47	Carrier	
200.00000000	-80.58	-13	67.58
1396.79359	-73.71	-13	60.71
6492.98597	-57.19	-13	44.19

Registration number: W6M20508-6114-C-1
FCC ID: CINSM-6100

Summary table with conducted data of the test plots for Carrier Test Frequency 806 MHz

Frequency Marker Indication [MHz]	Indication Power Level [dBm]	Compliance Limit [dBm]	Margin
805.96392786	7.97	Carrier	
200.00000000	-67.20	-13	54.20
1559.11824	-50.46	-13	37.46
6925.85170	-44.16	-13	31.16

9.3 Limit

Compliance with § 74.861 requires that any emission be attenuated below the transmitter power at least $43 + 10 \log_{10} P$ (P = transmitter power in Watts).

The compliance limit was calculated as an example per the following table :

Maximum transmitter output power	3.00 dBm
Required attenuation	$43 + 10 \log_{10} 0.001995262 \text{ W} = 16 \text{ dB}$
Maximum transmitter output power	3.00 dBm
<u>Required attenuation</u>	<u>16 dB</u>
Compliance limit	-13 dBm

Comment : see attached diagrams in appendix.

Registration number: W6M20508-6114-C-1
FCC ID: CINSM-6100

10 Radiated Spurious Emission , FCC 2.1053 ; 74.861 (e)

10.1 Test procedure

The EUT was positioned on a non-conductive turntable , 0.8m above the ground plane. The radiated emission at the fundamental frequency was measured at 3 m distance with a test antenna and spectrum analyzer. Worst case emission was recorded with the rotation of the turntable and the raising and lowering of the test antenna. ERP was measured using a substitution method. The EUT was replaced by reference antenna connected to a signal generator. The test of spurious radiated emission have been carried out with the ESK-Software from Rode & Schwarz. The measurements below 1GHz were performed with a measurement bandwidth of 100kHz, above 1GHz with a bandwidth of 1 MHz. Spurious emission limits near the carrier are defined by a emission mask. This measurements are done in conducted mode.

10.2 Test Results

The measurements of the spurious emission at the upper , center and lower channel. The measurement diagrams show that all significant spurs are well below the limit line.

Summary table with radiated data of the test plots for Carrier Test Frequency 614.5 MHz

Spectral Plot	Frequency Marker Indication [MHz]	Indication Power Level [dBm]	External Attn. [dB]	Worst Case Emission Level [dBm]	Compliance Limit [dBm]	Margin
vertical	195.090	-56.19		-56.19	-13	43.19
horizontal	196.844	-57.06		-57.06	-13	44.06
vertical	974.349	-68.58		-68.58	-13	55.58
horizontal	963.126	-68.05		-68.05	-13	55.05
vertical	3555	-49.51		-49.51	-13	35.51
horizontal	3555	-49.09		-49.09	-13	36.09
vertical	7535	-43.25		-43.25	-13	30.25
horizontal	7511	-42.07		-42.07	-13	29.07
vertical	12188	-34.39		-34.39	-13	21.39
horizontal	12208	-34.93		-34.93	-13	21.93

Registration number: W6M20508-6114-C-1
FCC ID: CINSM-6100

**Summary table with radiated data of the test plots for Carrier Test Frequency
710 MHz**

Spectral Plot	Frequency Marker Indication [MHz]	Indication Power Level [dBm]	External Attn. [dB]	Worst Case Emission Level [dBm]	Compliance Limit [dBm]	Margin
vertical	196.493	-56.00		-56.00	-13	43.00
horizontal	52.004	-57.10		-57.10	-13	44.10
vertical	953.507	-68.50		-68.50	-13	55.50
horizontal	955.110	-66.10		-66.10	-13	53.10
vertical	3531	-50.45		-50.45	-13	37.45
horizontal	1415	-45.08		-45.08	-13	32.08
vertical	7599	-42.92		-42.92	-13	29.92
horizontal	7519	-42.47		-42.47	-13	29.47
vertical	12108	-34.74		-34.74	-13	21.74
horizontal	12188	-35.09		-35.09	-13	22.09

**Summary table with radiated data of the test plots for Carrier Test Frequency
806 MHz**

Spectral Plot	Frequency Marker Indication [MHz]	Indication Power Level [dBm]	External Attn. [dB]	Worst Case Emission Level [dBm]	Compliance Limit [dBm]	Margin
vertical	190.180	-56.21		-56.21	-13	43.21
horizontal	191.583	-56.75		-56.75	-13	43.75
vertical	953.507	-68.50		-68.50	-13	55.50
horizontal	979.158	-68.43		-68.43	-13	55.43
vertical	1607	-47.11		-47.11	-13	34.11
horizontal	1607	-44.19		-44.19	-13	31.19
vertical	7535	-42.96		-42.96	-13	29.96
horizontal	7455	-42.31		-42.31	-13	29.31
vertical	12178	-33.71		-33.71	-13	20.71
horizontal	12178	-34.84		-34.84	-13	21.84



Registration number: W6M20508-6114-C-1
 FCC ID: CINSM-6100

10.3 Explanation of test result

The measurements of the spurious emissions at the equipment output terminals were performed pursuant to the test procedure above in order to verify that any emissions are below the limits given by § 74.861 (6).

Calculation of test results :

Such factors like antenna correction , cable loss , external attenuation etc. are already included in the provided measurement results. This is done by using validated test software and calibrated test system according the accreditation requirements.

In the Table being listed the critical peak and average value an exhibit the compliance with the above calculated Limits.

10.4 Limits

Compliance with § 74.861 requires that any emission be attenuated below the transmitter power at least $43 + 10 \log_{10} P$ (P = transmitter power in Watts).

The compliance limit was calculated as an example per the following table :

Maximum transmitter output power	3.81 dBm
Required attenuation	$43 + 10 \log_{10} 0.002404363W = 16.81 \text{ dB}$
Maximum transmitter output power	3.81 dBm
<u>Required attenuation</u>	<u>16.81 dB</u>
Compliance limit	-13 dBm

Comment : see attached diagrams in appendix.

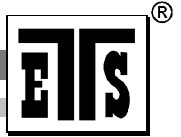

Registration number: W6M20508-6114-C-1
 FCC ID: CINSM-6100

11 Line Conducted Emission , FCC 15.207

11.1 Test procedure

For an intentional radiator which is designed to be connected to the public utility (AC) power line, the radio frequency voltage that is conducted back onto the AC line on any frequency or frequencies within the band 150 kHz to 30 MHz shall not exceed the limits in the table bellows with this provision shall be based on the measurement of the radio frequency voltage between each power line and ground at the power terminals.

This measurement was transact first with instrumentation using an average and peak detector and a 10 kHz bandwidth. If the peak detector achieves a calculated level, the measurement is repeated by an instrumentation using a quasi-peak detector.

11.2 Test Results

Frequency	Max. Level (dBμV)	
	quasi-peak	average
-- kHz	--	--

Limits:

Frequency of Emission (MHz)	Conducted Limit (dBuV)	
	Quasi Peak	Average
0.15-0.5	66 to 56	56 to 46
0.5-5	56	46
5-30	60	50

Comment : The is not required the sample is battery used.

Registration number: W6M20508-6114-C-1
FCC ID: CINSM-6100

12 Frequency Stability vs. Temperature , FCC 2.1055 , 74.861 (e)

12.1 Test procedure

The equipment under test was connected to an external DC power supply and the RF output was connected to a frequency counter via feed through attenuators. The EUT was placed inside the temperature chamber. The DC leads and RF output cable, exited the chamber through an opening made for that purpose.

After the temperature stabilized the frequency output was recorded from the counter.

12.2 Test Results

614.5 MHz

°C	Frequency Error (kHz)	Frequency Error (ppm)
-30	5.91	0.000962
-20	4.88	0.000794
-10	4.02	0.000654
0	3.46	0.000563
10	3.18	0.000517
20	2.79	0.000454
30	2.32	0.000378
40	1.78	0.000290
50	1.6	0.000260

710 MHz

°C	Frequency Error (kHz)	Frequency Error (ppm)
-30	5.91	0.000844
-20	1.28	0.000183
-10	-3.71	-0.000530
0	-5.71	-0.000816
10	-6.32	-0.000903
20	-6.74	-0.000963
30	-7.28	-0.001040
40	-7.81	-0.001116
50	-8.03	-0.001147

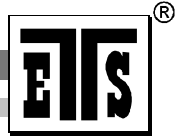

Registration number: W6M20508-6114-C-1
FCC ID: CINSM-6100

806 MHz

°C	Frequency Error (kHz)	Frequency Error (ppm)
-30	3.79	0.000485
-20	-1.78	-0.000228
-10	-4.01	-0.000513
0	-7.68	-0.000983
10	-8.02	-0.001027
20	-8.17	-0.001046
30	-8.26	-0.001058
40	-8.39	-0.001074
50	-8.56	-0.001096

Limit : $\pm 0.005\%$

Registration number: W6M20508-6114-C-1
FCC ID: CINSM-6100

13 Frequency Stability vs. Voltage , FCC 2.1055 (d) ; 74.861 (e)

13.1 Test procedure

An external variable DC power supply was connected to the battery terminals of the equipment under test.

For hand carried , battery powered equipment primary supply voltage was reduced to the battery operating end point as specified by the manufacturer. The output frequency was recorded for each battery voltage.

13.2 Test Results

Frequency in MHz	Frequency Error (kHz)	Frequency Error (ppm)
614.5	2.79	0,00454
710	-6.74	-0,000963
806	-8.17	-0,001046

Limit : $\pm 0.005\%$

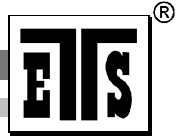

Registration number: W6M20508-6114-C-1
FCC ID: CINSM-6100

Appendix

- A RF Power Output
- B Audio frequency response
- C Occupied Bandwidth / Emission Mask
- D Spurious Emissions at Antenna Terminals
- E Radiation Spurious Emission
- F Line Conducted Emissions
- G Frequency Stability vs. Temperature
- H Frequency Stability vs. Voltage
- I Pictures

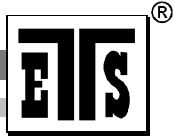

Registration number: W6M20508-6114-C-1
FCC ID: CINSM-6100

Appendix A

RF Power Output

(The measurement diagram are wideband pre-scan results; only for reference.)



Ref 10 dBm *Att 30 dB *RBW 30 kHz Marker 1 [T1]
*VBW 100 kHz 3.00 dBm
*SWT 200 ms 614.499600000 MHz

1 PK
MAXH

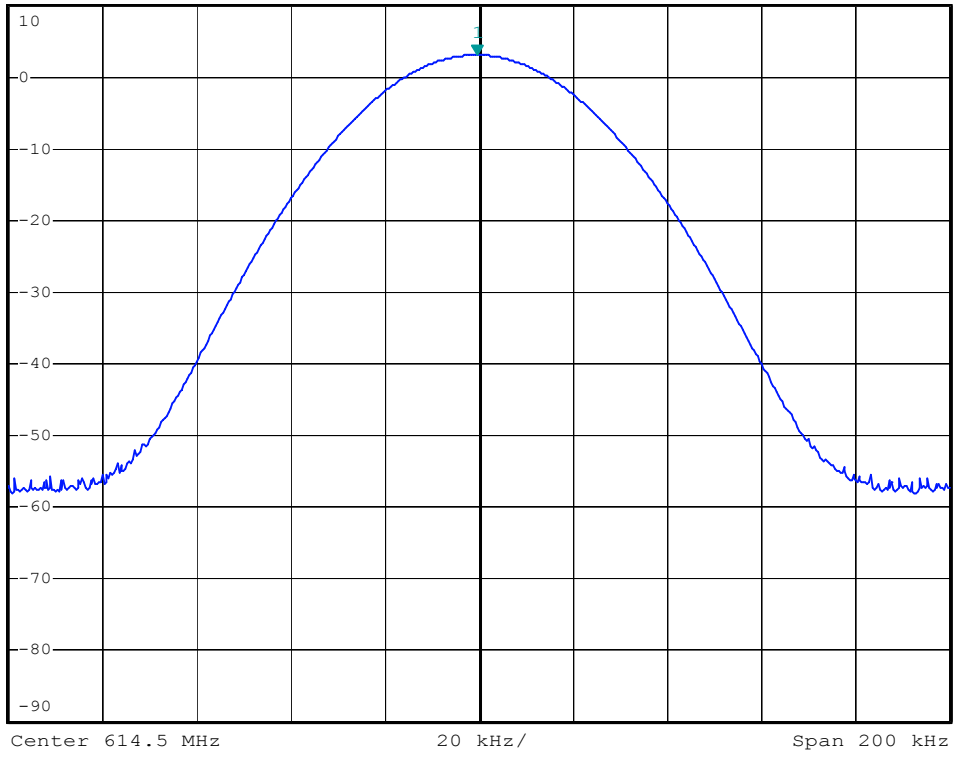

614.5 OUTPUTX POWER

Date: 20.SEP.2005 11:32:16



Ref 10 dBm *Att 30 dB *RBW 30 kHz Marker 1 [T1]
*VBW 100 kHz 1.03 dBm
*SWT 200 ms 709.999600000 MHz

1 PK
MAXH

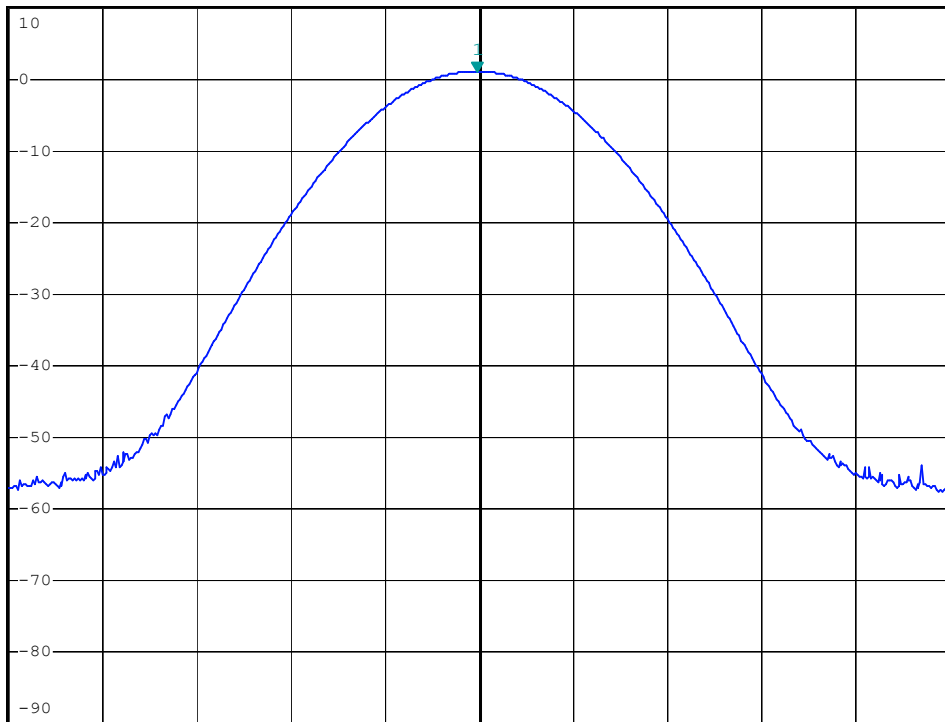

Center 709 MHz 20 kHz/ Span 200 kHz

710 OUTPUTX POWER

Date: 20.SEP.2005 11:31:08



Ref 0 dBm Att 30 dB *RBW 30 kHz Marker 1 [T1]
*VBW 100 kHz -4.08 dBm
*SWT 200 ms 806.00000000 MHz

1 PK
MAXH

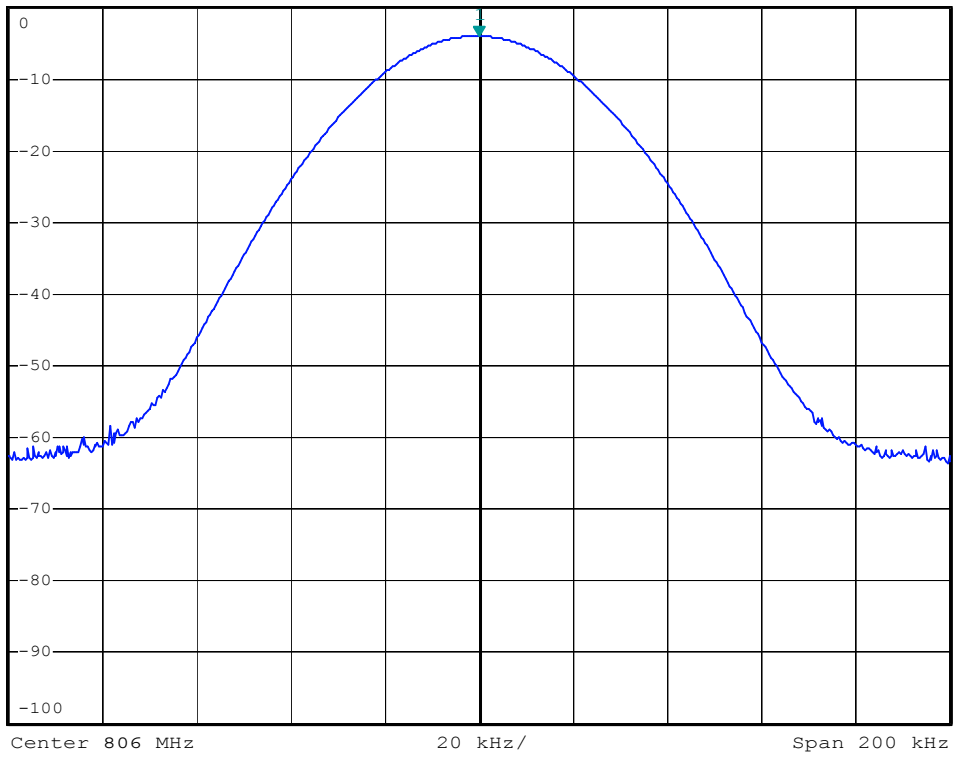

806 OUTPUTX POWER

Date: 20.SEP.2005 11:29:04

Transmitter carrier power under normal conditions

in according to FCC Part 74.861

EUT: Wireless Microphone
MODEL NO.: SM-6100 614.5MHz
Approval Holder: CHIAYO ELECTRONICS CO.,LTD.
Test Site / Operator: ETS / Mike Wu
Temperature/Voltage: Temp.: 23°C/ Unom.: 3 VDC (1.5V Battery x 2)
Test Specification: 74.861
Comment 1: Dist.: 3m, Ant.: HL 223
Freq:614.502MHz Pmax:3.81dBm RBW: 100 kHz

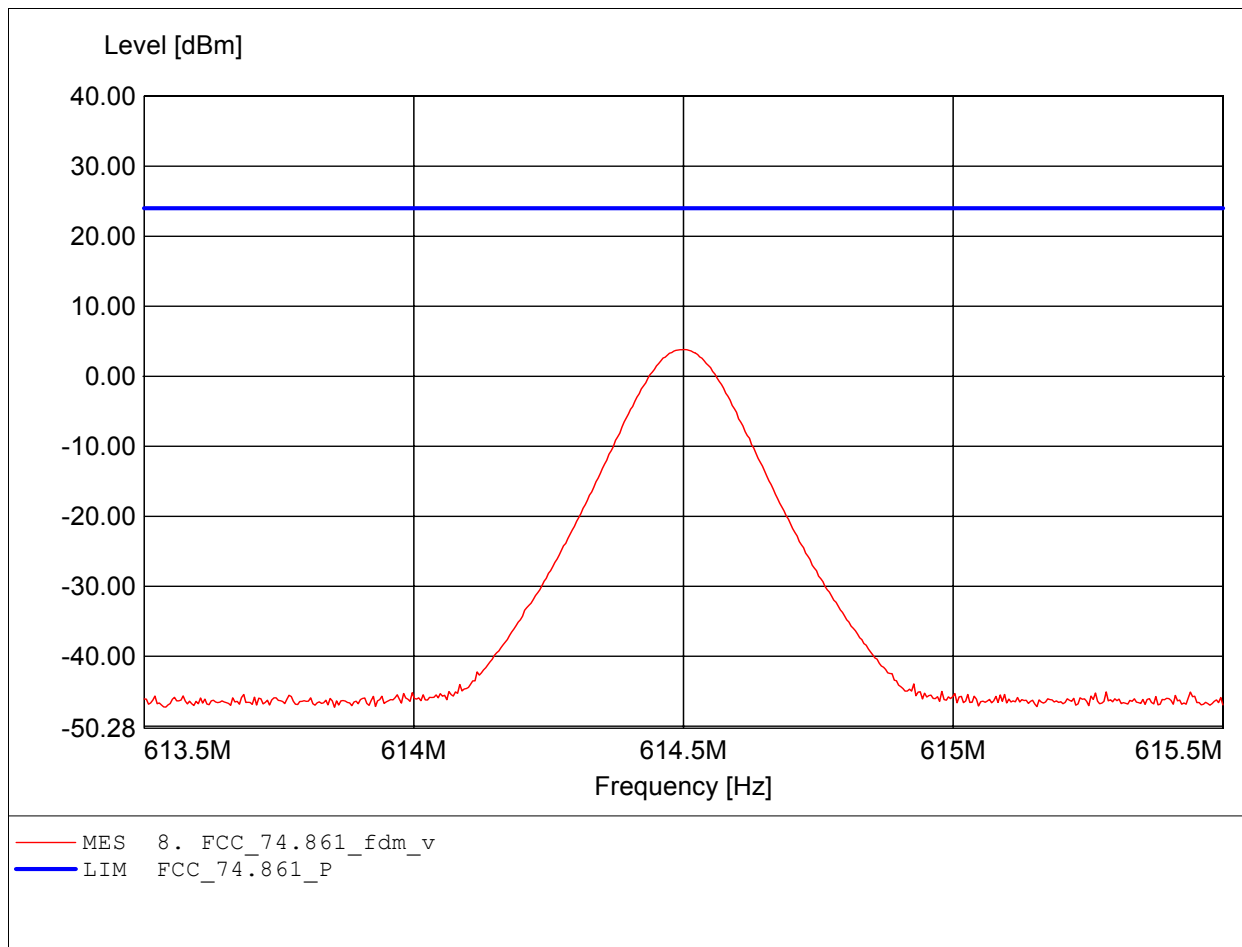

Transmitter carrier power under normal conditions

in according to FCC Part 74.861

EUT: Wireless Microphone
MODEL NO.: SM-6100 614.5MHz
Approval Holder: CHIAYO ELECTRONICS CO.,LTD.
Test Site / Operator: ETS / Mike Wu
Temperature/Voltage: Temp.: 23°C/ Unom.: 3 VDC (1.5V Battery x 2)
Test Specification: 74.861
Comment 1: Dist.: 3m, Ant.: HL 223
Freq:614.494MHz Pmax:-0.26dBm RBW: 100 kHz

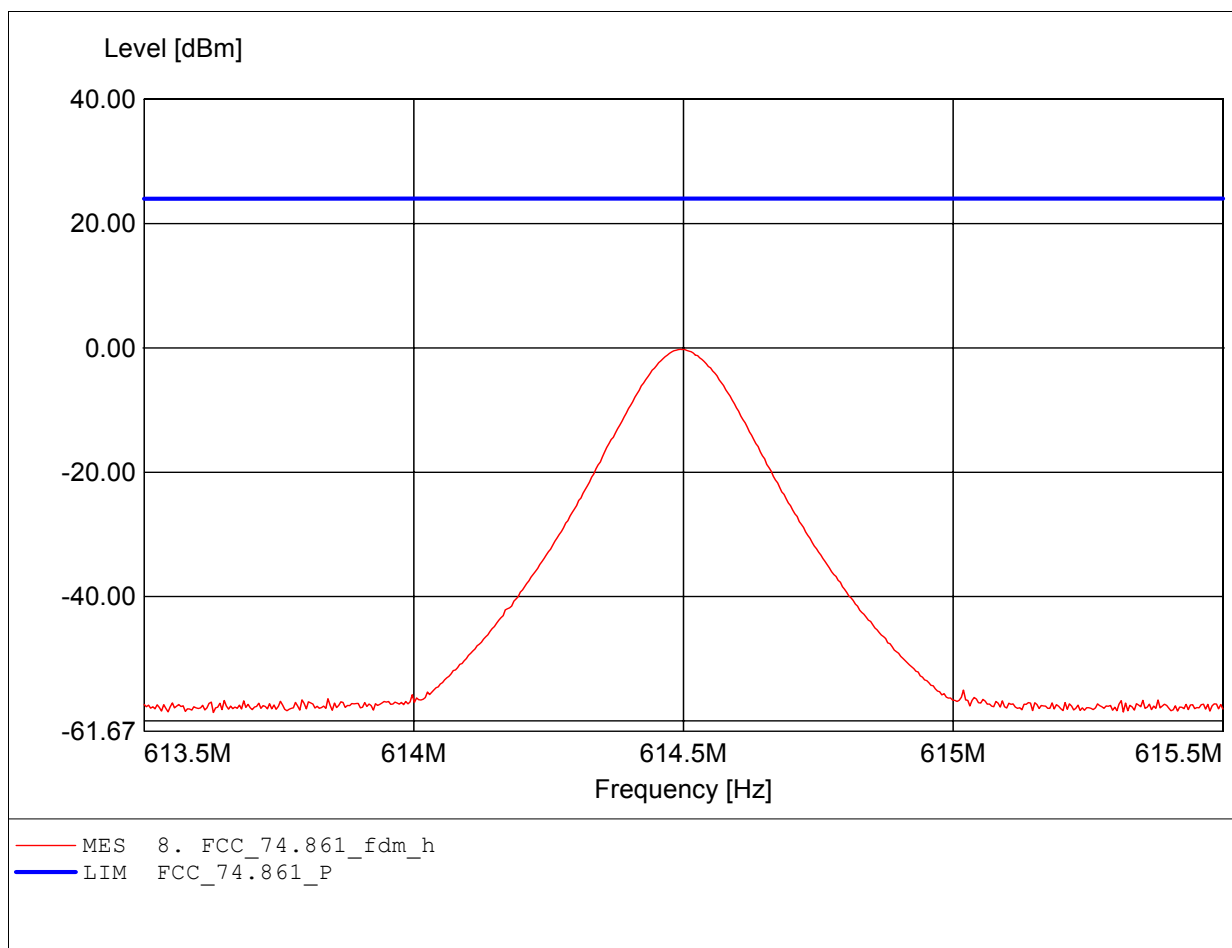

Transmitter carrier power under normal conditions

in according to FCC Part 74.861

EUT: Wireless Microphone
MODEL NO.: SM-6100 710MHz
Approval Holder: CHIAYO ELECTRONICS CO.,LTD.
Test Site / Operator: ETS / Mike Wu
Temperature/Voltage: Temp.: 23°C/ Unom.: 3 VDC (1.5V Battery x 2)
Test Specification: 74.861
Comment 1: Dist.: 3m, Ant.: HL 223
Freq:710.000MHz Pmax:1.14dBm RBW: 100 kHz

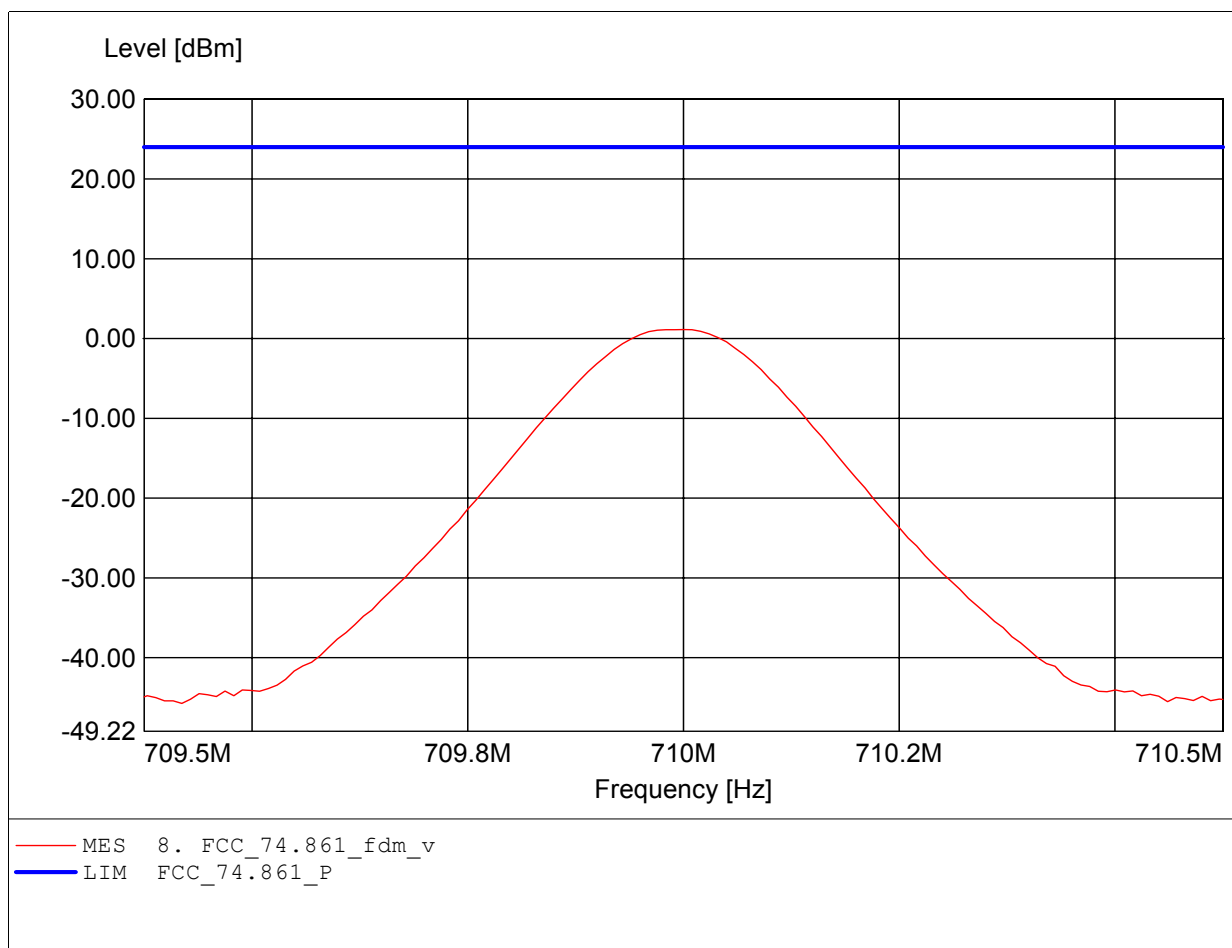

Transmitter carrier power under normal conditions

in according to FCC Part 74.861

EUT: Wireless Microphone
MODEL NO.: SM-6100 710MHz
Approval Holder: CHIAYO ELECTRONICS CO.,LTD.
Test Site / Operator: ETS / Mike Wu
Temperature/Voltage: Temp.: 23°C/ Unom.: 3 VDC (1.5V Battery x 2)
Test Specification: 74.861
Comment 1: Dist.: 3m, Ant.: HL 223
Freq:709.984MHz Pmax:-1.72dBm RBW: 100 kHz

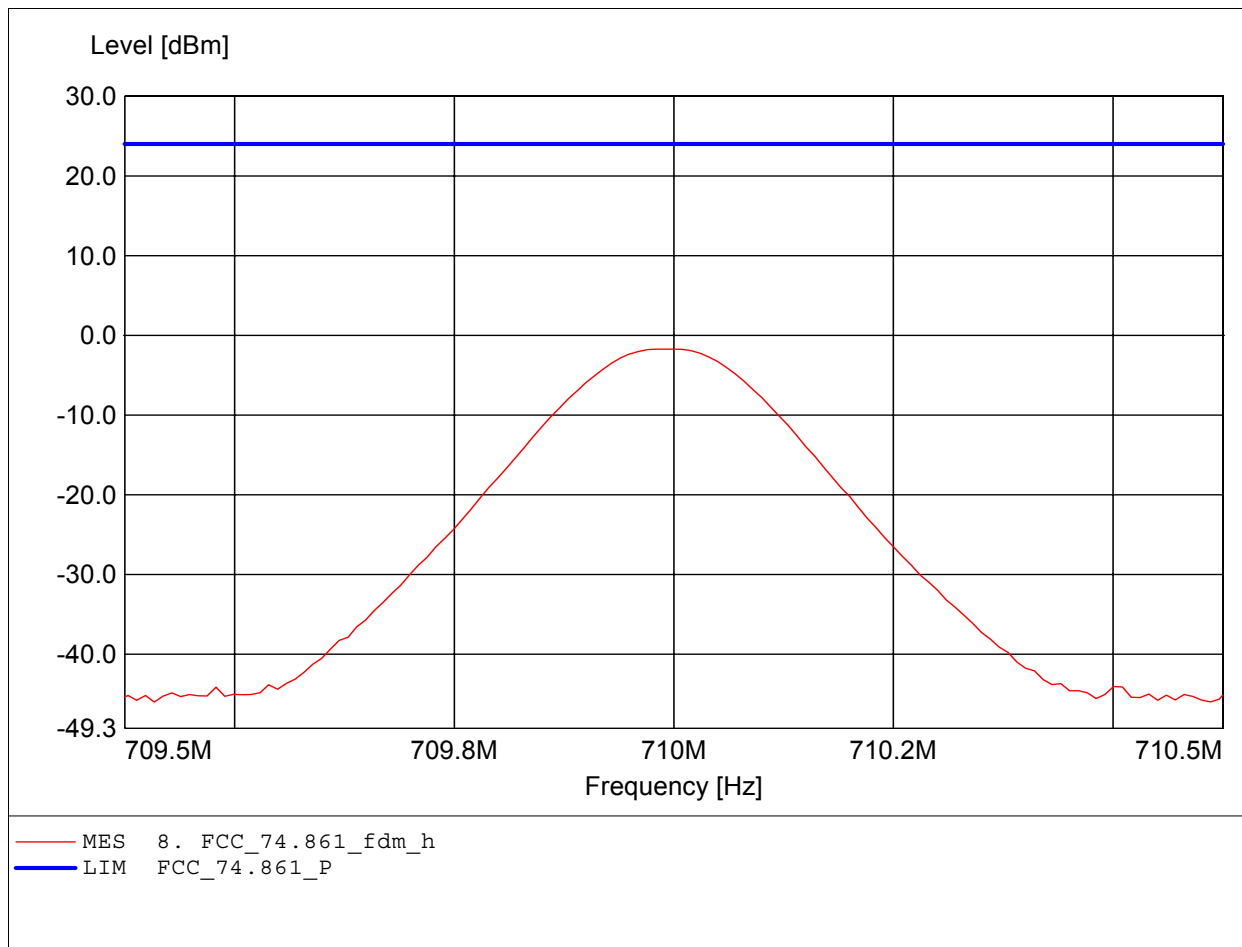

Transmitter carrier power under normal conditions

in according to FCC Part 74.861

EUT: Wireless Microphone
MODEL NO.: SM-6100 806MHz
Approval Holder: CHIAY O ELECTRONICS CO.,LTD.
Test Site / Operator: ETS / Mike Wu
Temperature/Voltage: Temp.: 23°C/ Unom.: 3 VDC (1.5V Battery x 2)
Test Specification: 74.861
Comment 1: Dist.: 3m, Ant.: HL 223
Freq:805.745MHz Pmax:-3.13dBm RBW: 100 kHz

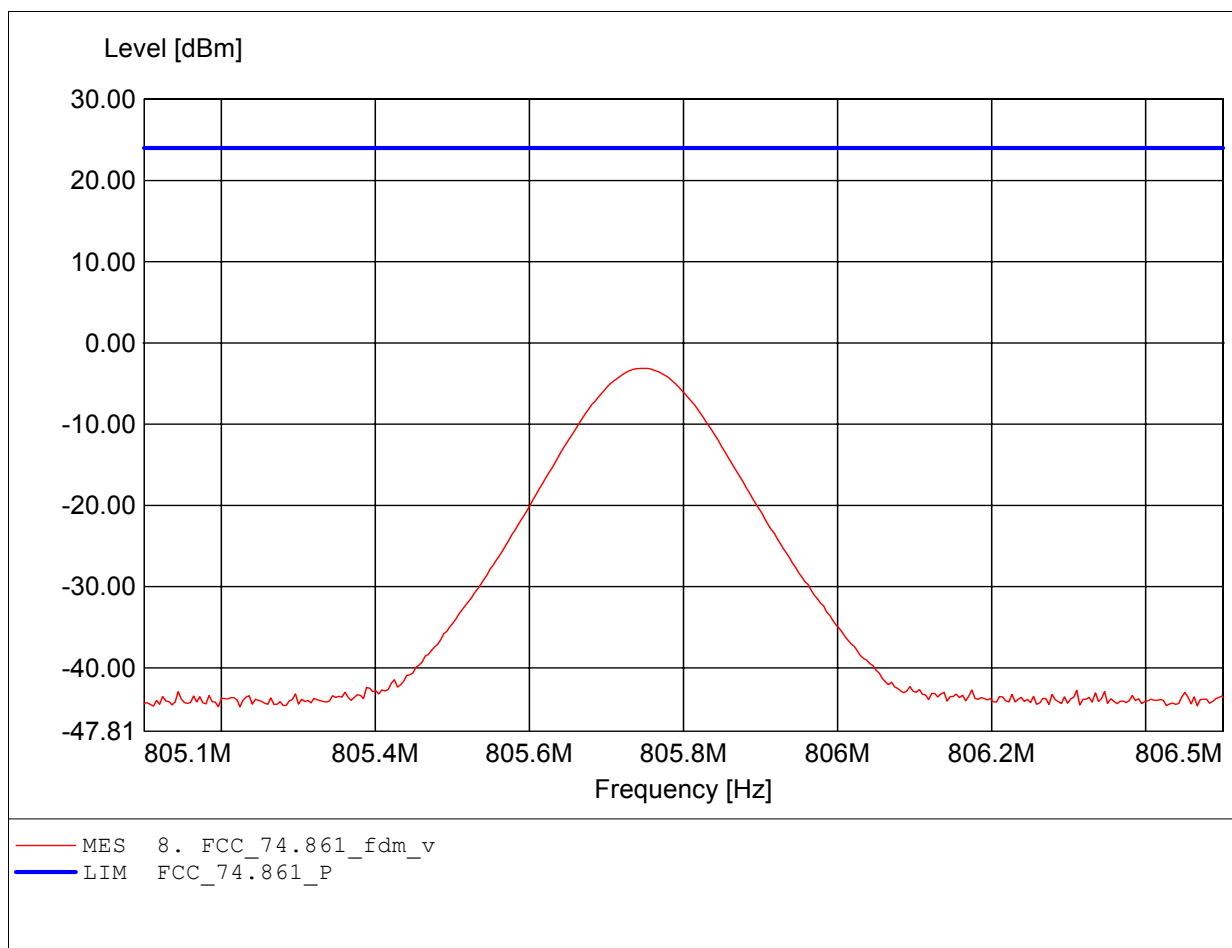

Transmitter carrier power under normal conditions

in according to FCC Part 74.861

EUT: Wireless Microphone
MODEL NO.: SM-6100 806MHz
Approval Holder: CHIAYO ELECTRONICS CO.,LTD.
Test Site / Operator: ETS / Mike Wu
Temperature/Voltage: Temp.: 23°C/ Unom.: 3 VDC (1.5V Battery x 2)
Test Specification: 74.861
Comment 1: Dist.: 3m, Ant.: HL 223
Freq:805.748MHz Pmax:-12.50dBm RBW: 100 kHz

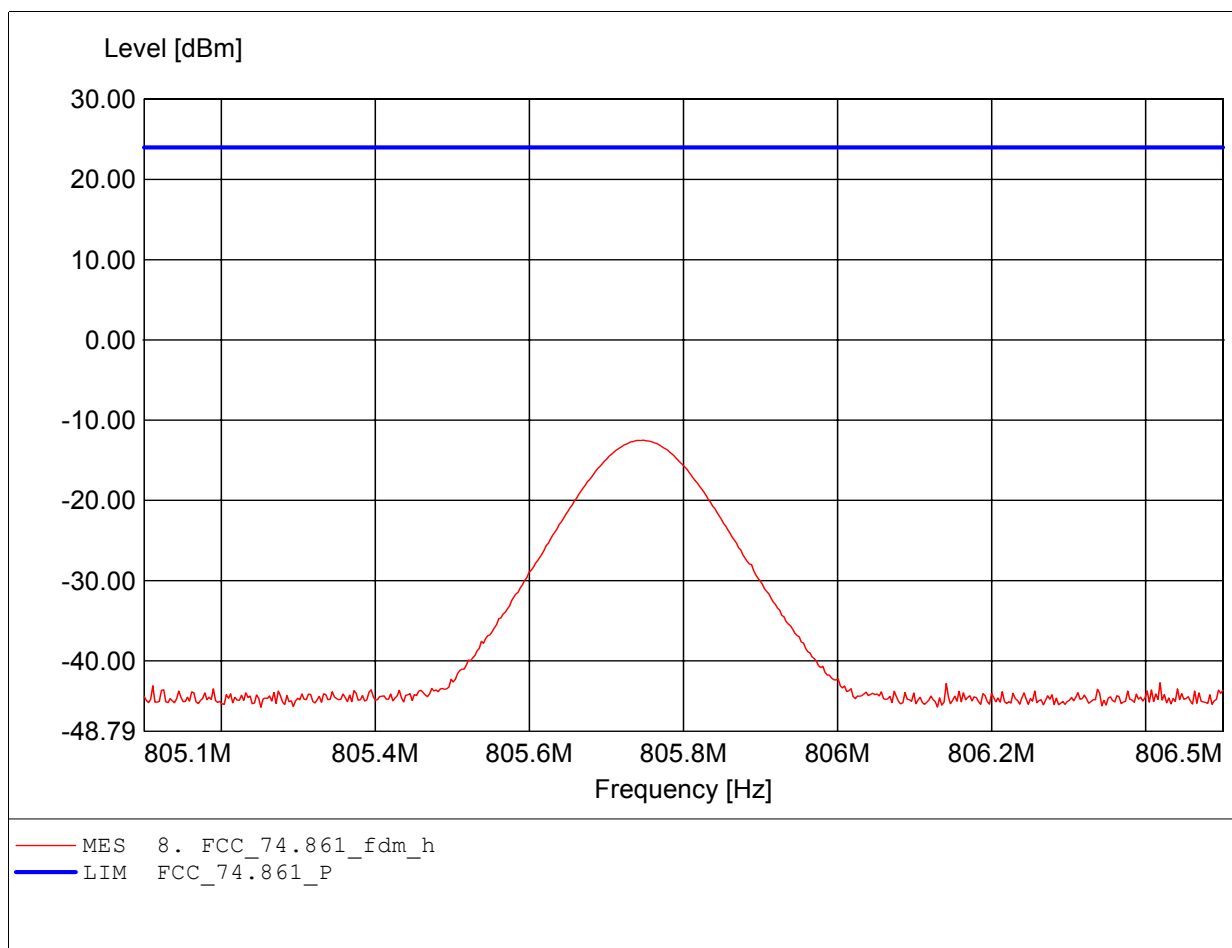



Registration number: W6M20508-6114-C-1
FCC ID: CINSM-6100

Appendix B

Audio frequency response

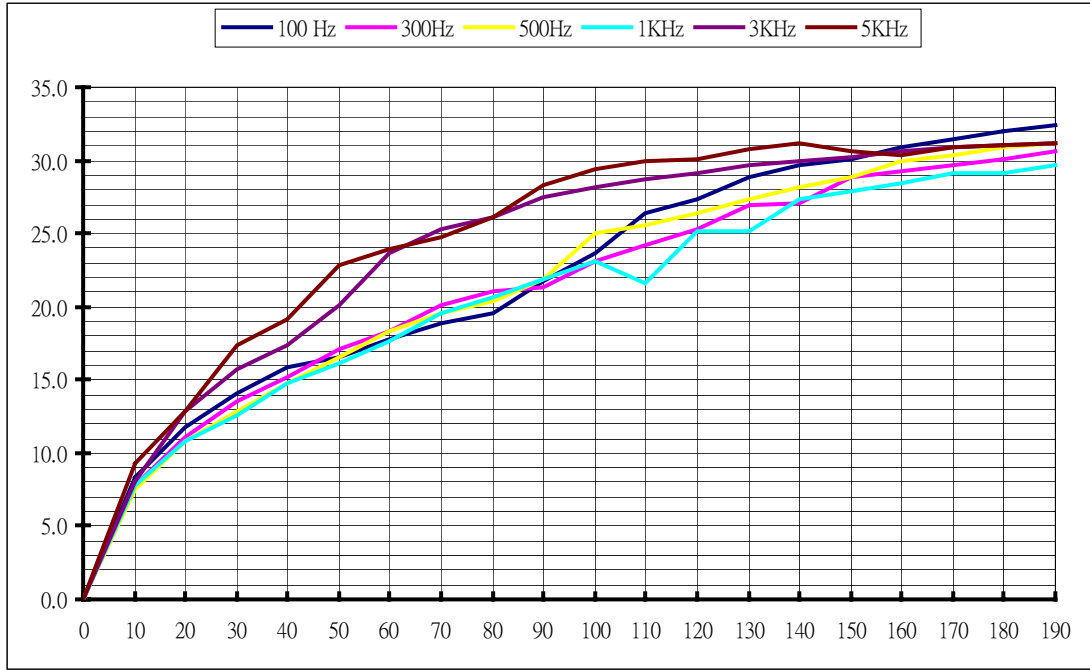

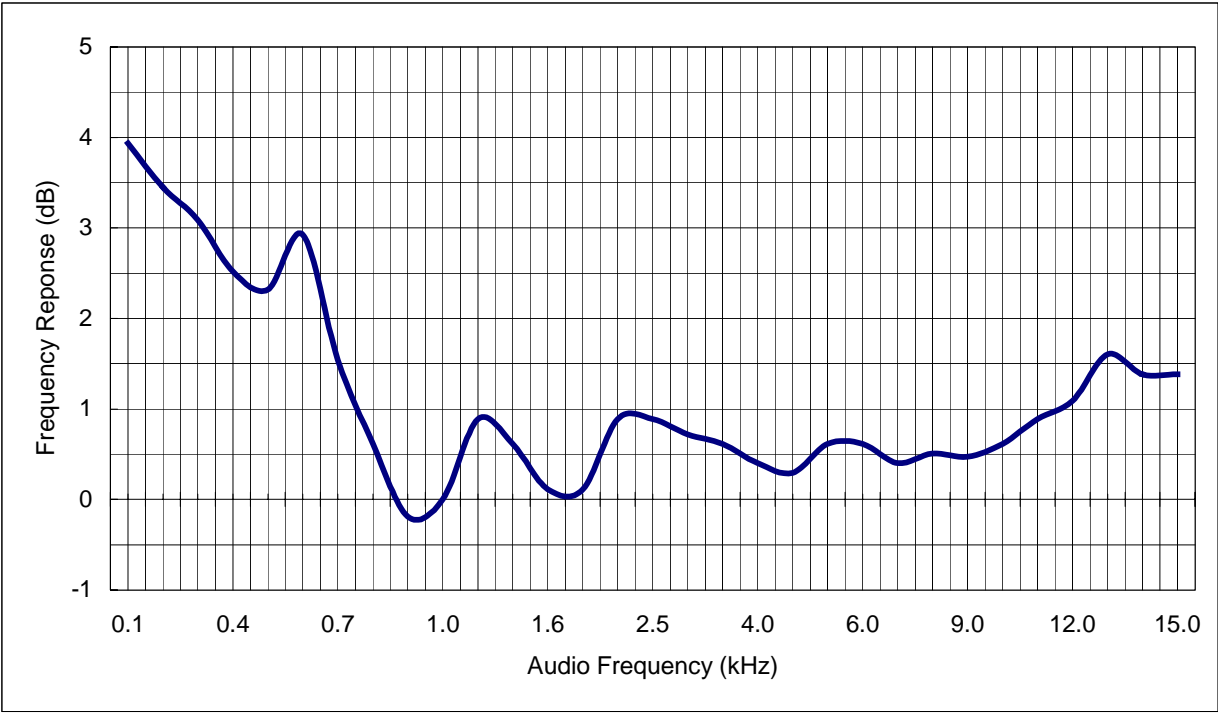

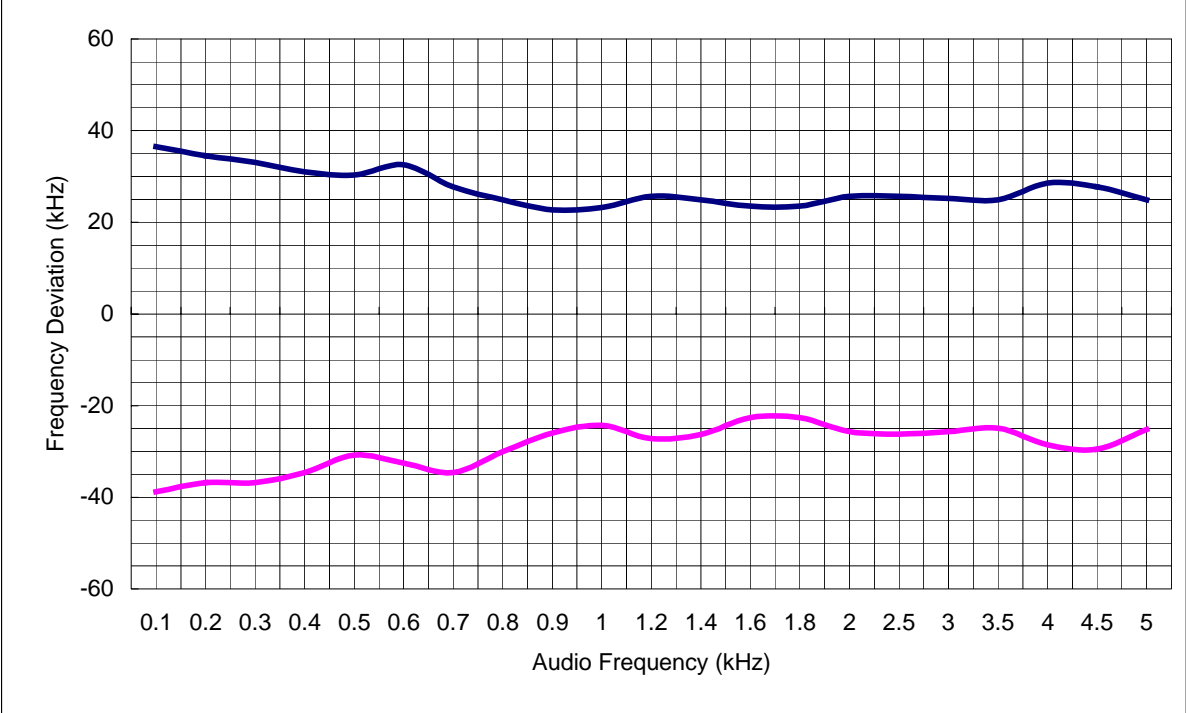

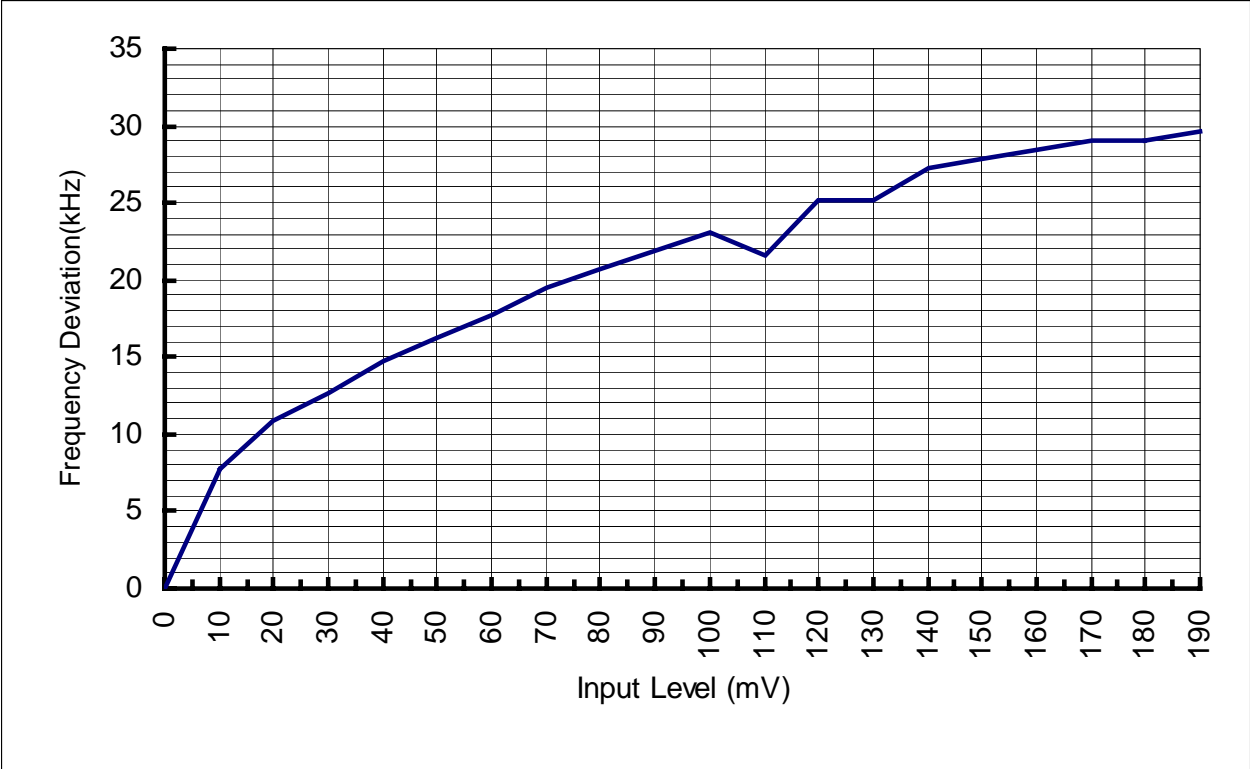



Registration number: W6M20508-6114-C-1
FCC ID: CINSM-6100

Appendix C

Occupied Bandwidth / Emission Mask



Marker 1 [T1] RBW 3 kHz RF Att 20 dB
Ref Lvl -40.35 dBm VBW 3 kHz
-15 dBm 614.5000000 MHz SWT 100 ms Unit dBm

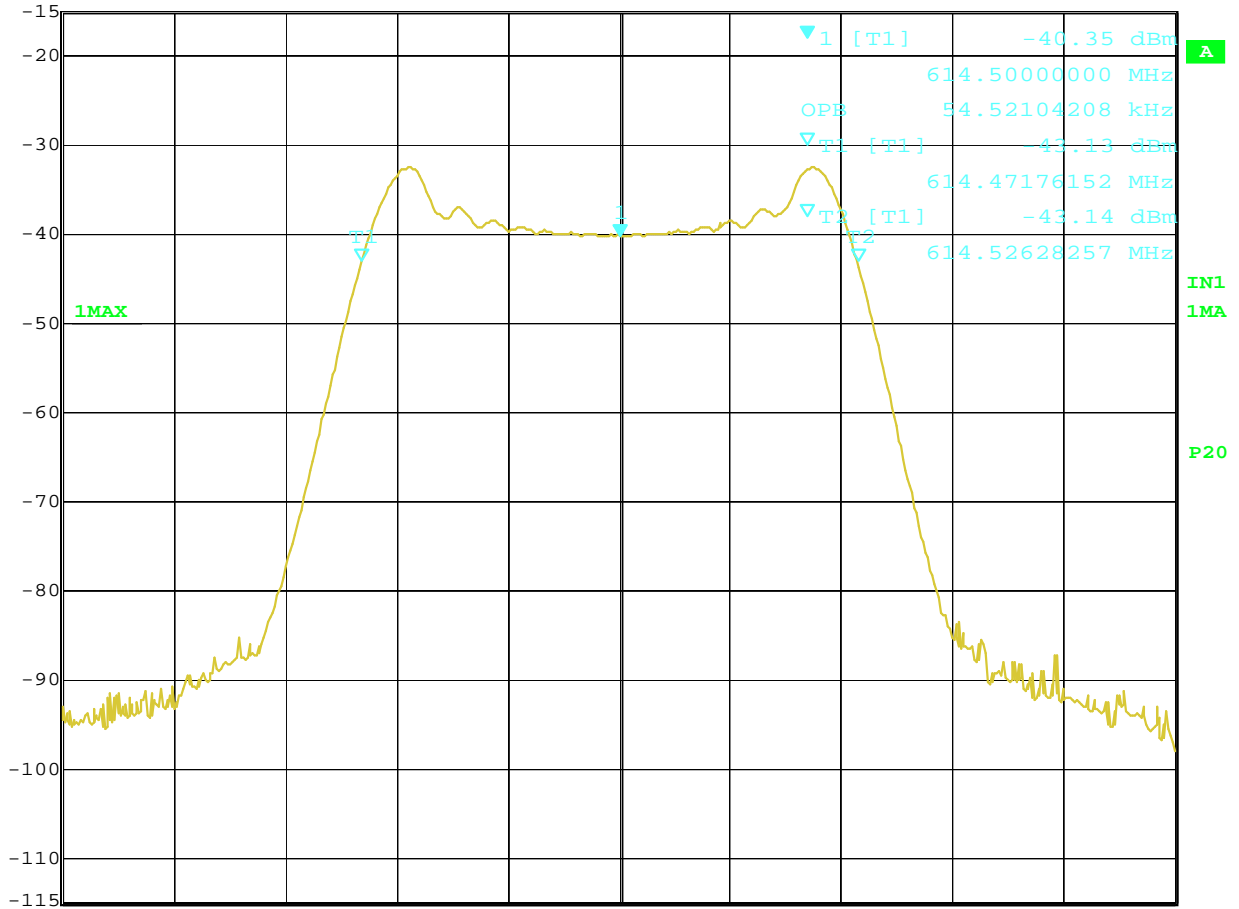

Center 614.5 MHz 12.2 kHz/ Span 122 kHz

Title: 614.5MHz With 1000Hz modulation
Comment A: CHIAYO ELECTRONICS CO.,LTD.
Date: 8.SEP.2005 17:45:48



Marker 1 [T1] RBW 3 kHz RF Att 20 dB
 Ref Lvl -42.03 dBm VBW 3 kHz
 -15 dBm 614.50000000 MHz SWT 100 ms Unit dBm

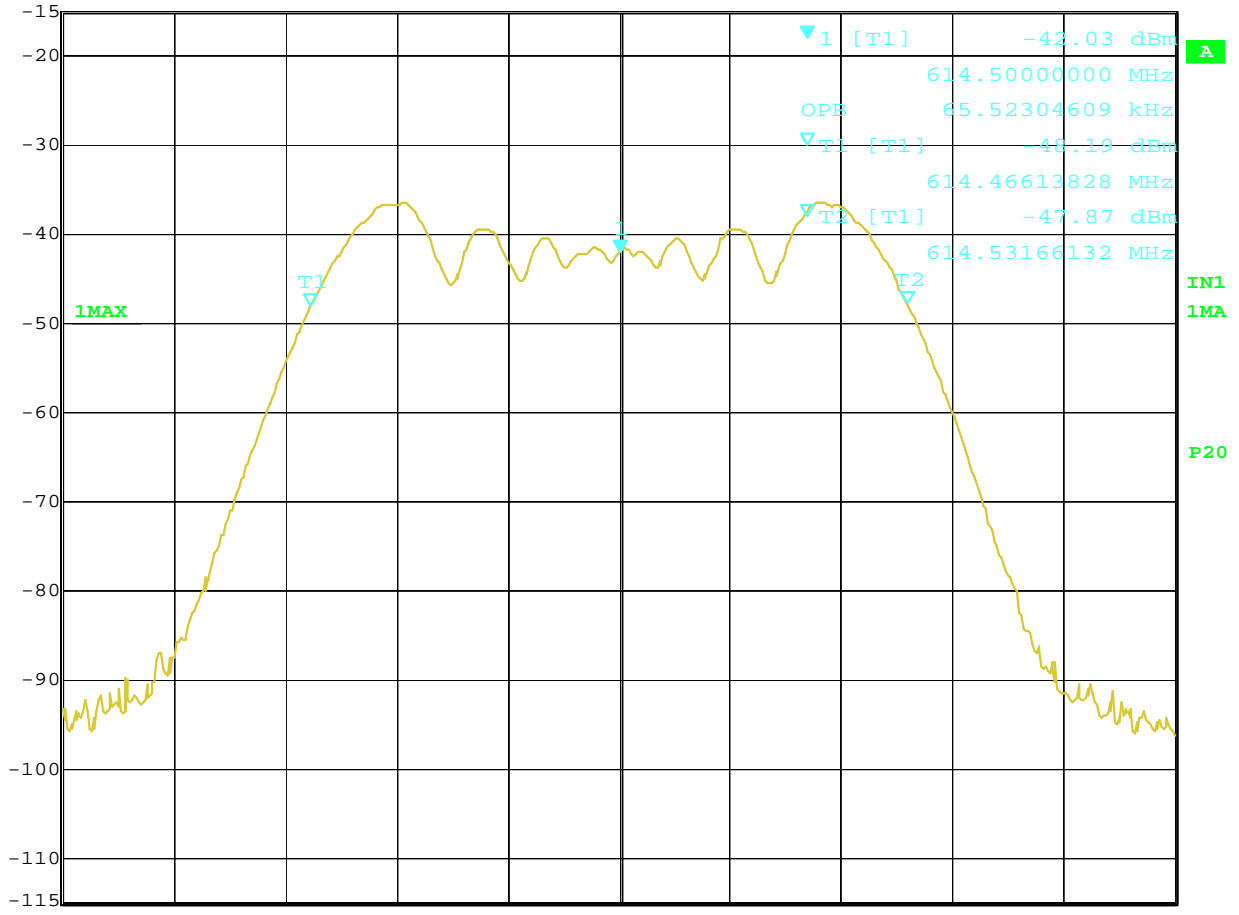

Center 614.5 MHz 12.2 kHz/ Span 122 kHz

Title: 614.5MHz With 2500Hz modulation
 Comment A: CHIAYO ELECTRONICS CO.,LTD.
 Date: 8.SEP.2005 17:46:50



Marker 1 [T1] RBW 3 kHz RF Att 20 dB
Ref Lvl -40.76 dBm VBW 3 kHz
-15 dBm 710.00061623 MHz SWT 100 ms Unit dBm

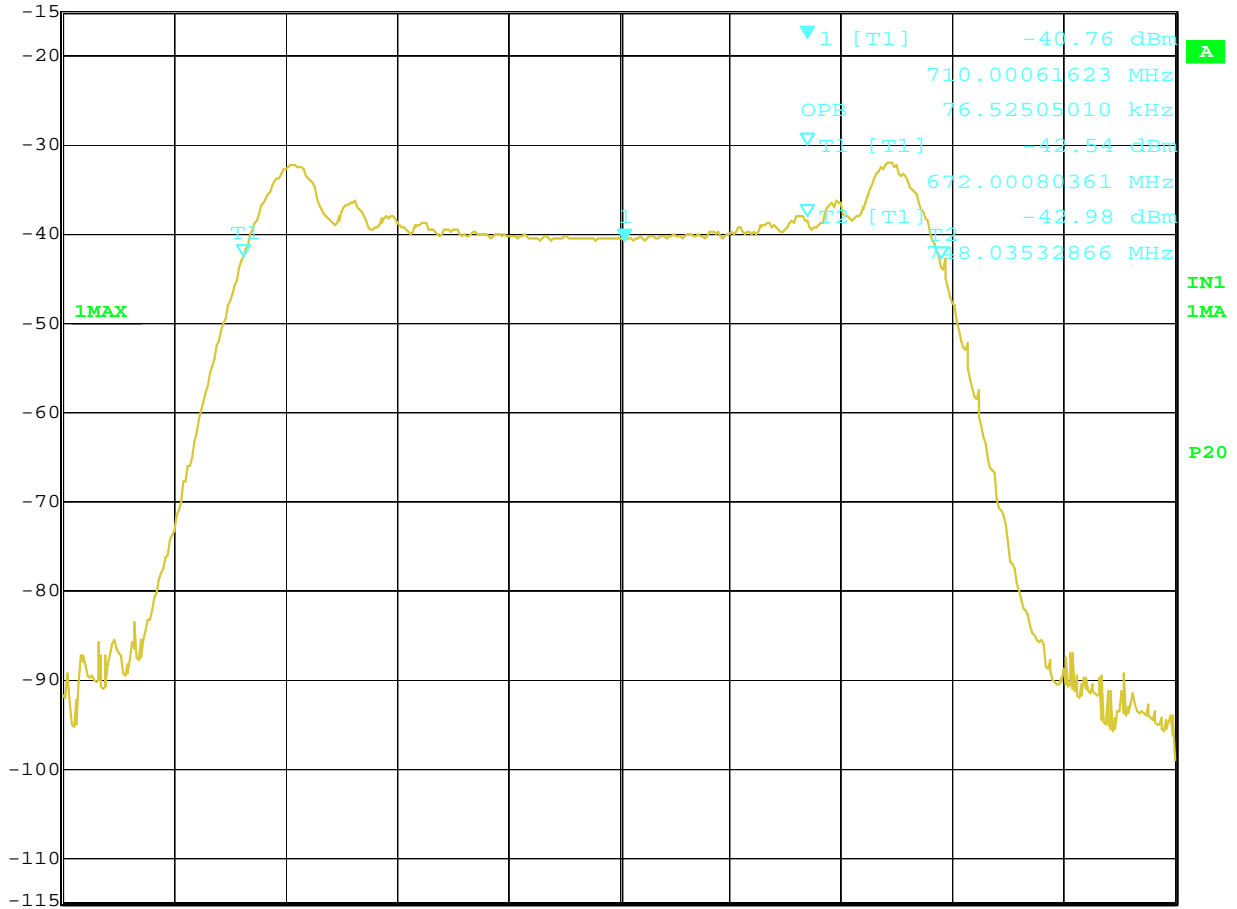

Title: 710MHz With 1000Hz modulation
Comment A: CHIAYO ELECTRONICS CO.,LTD.
Date: 8.SEP.2005 18:07:10



Marker 1 [T1] RBW 3 kHz RF Att 20 dB
Ref Lvl -15 dBm -42.35 dBm VBW 3 kHz
710.00061623 MHz SWT 100 ms Unit dBm

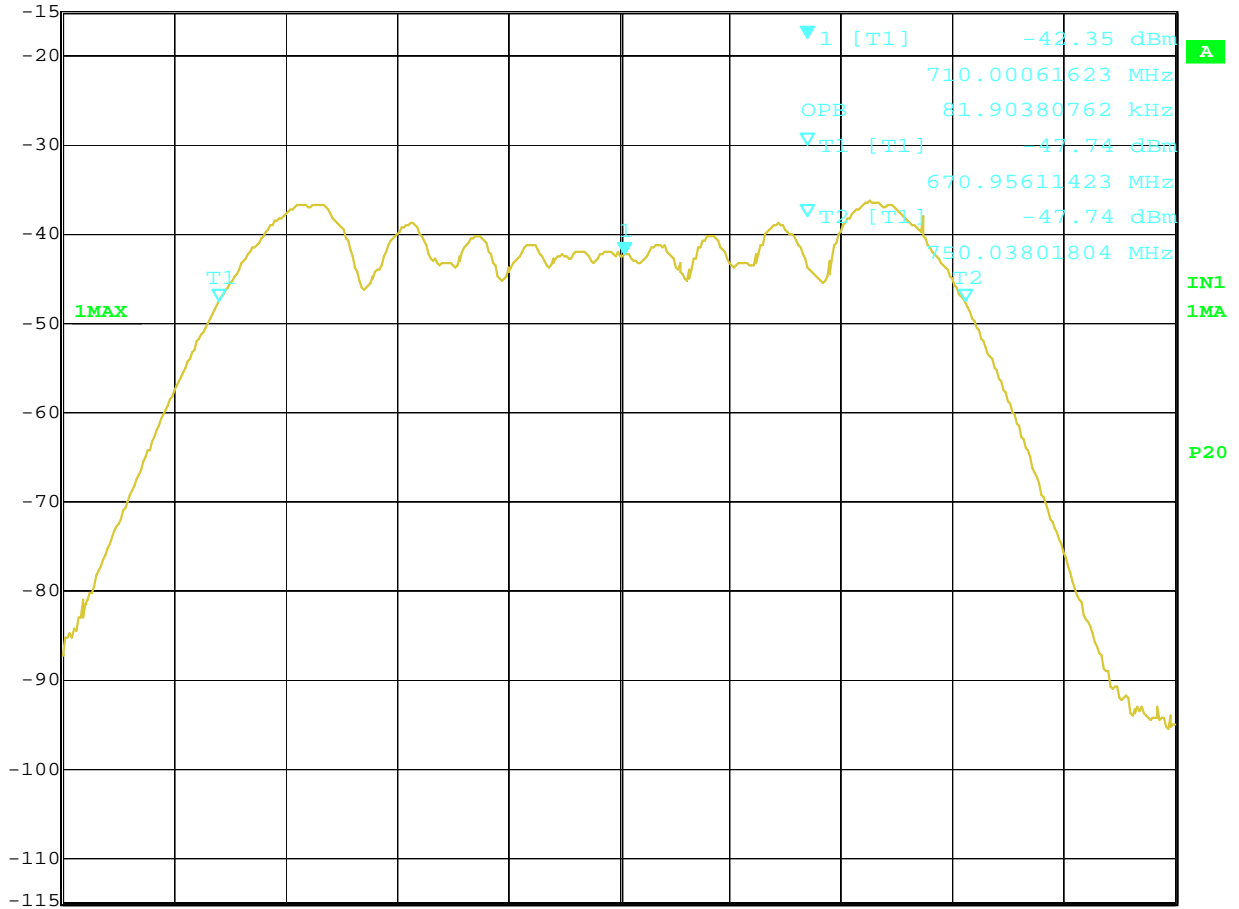

Center 710 MHz 12.2 kHz/ Span 122 kHz

Title: 710MHz With 2500Hz modulation
Comment A: CHIAYO ELECTRONICS CO.,LTD.
Date: 8.SEP.2005 18:07:48



Marker 1 [T1] RBW 3 kHz RF Att 20 dB
 Ref Lvl -44.43 dBm VBW 3 kHz
 -15 dBm 806.00000000 MHz SWT 100 ms Unit dBm

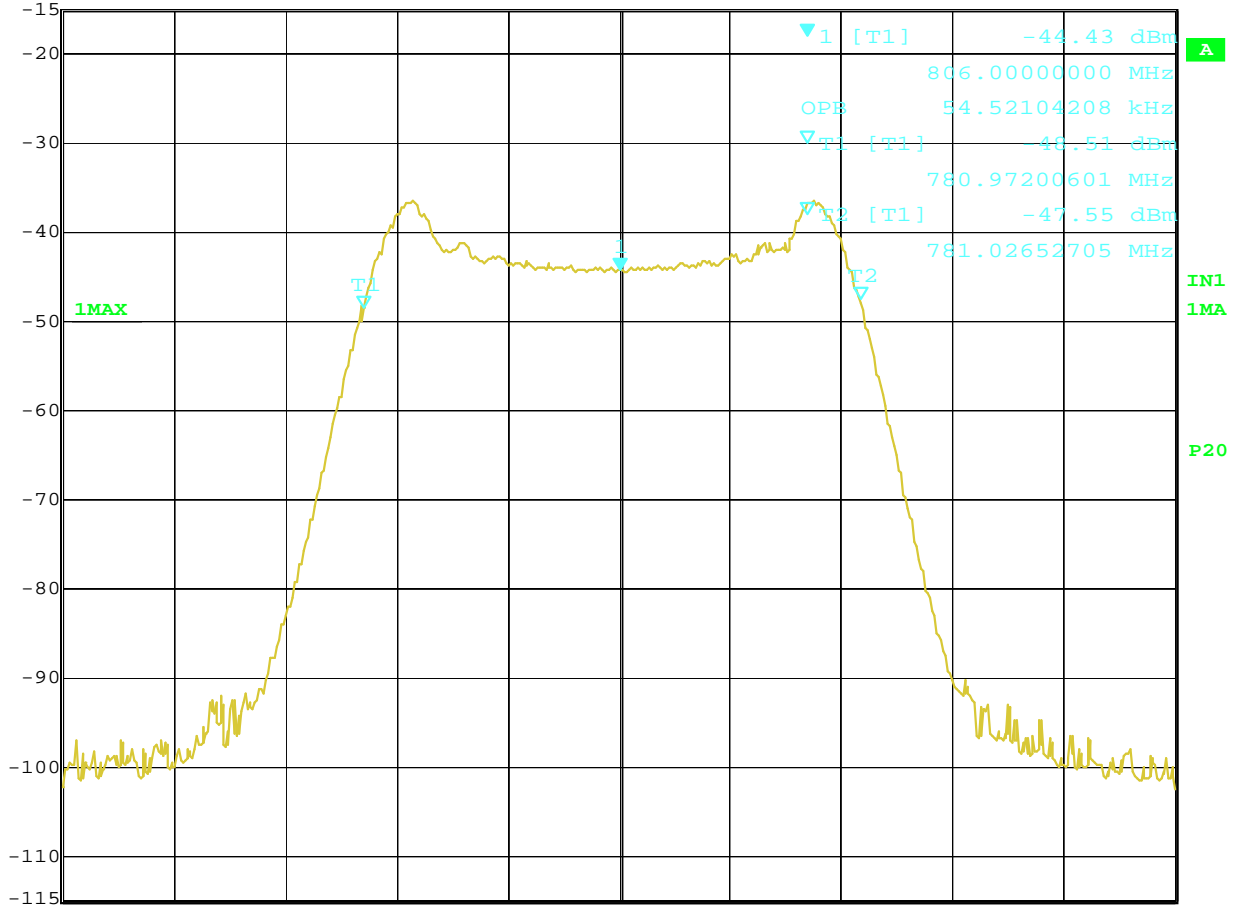

Center 806 MHz 12.2 kHz/ Span 122 kHz

Title: 806MHz With 1000Hz modulation
 Comment A: CHIAYO ELECTRONICS CO.,LTD.
 Date: 8.SEP.2005 17:51:12



Marker 1 [T1] RBW 3 kHz RF Att 20 dB
Ref Lvl -45.99 dBm VBW 3 kHz
-15 dBm 806.00000000 MHz SWT 100 ms Unit dBm

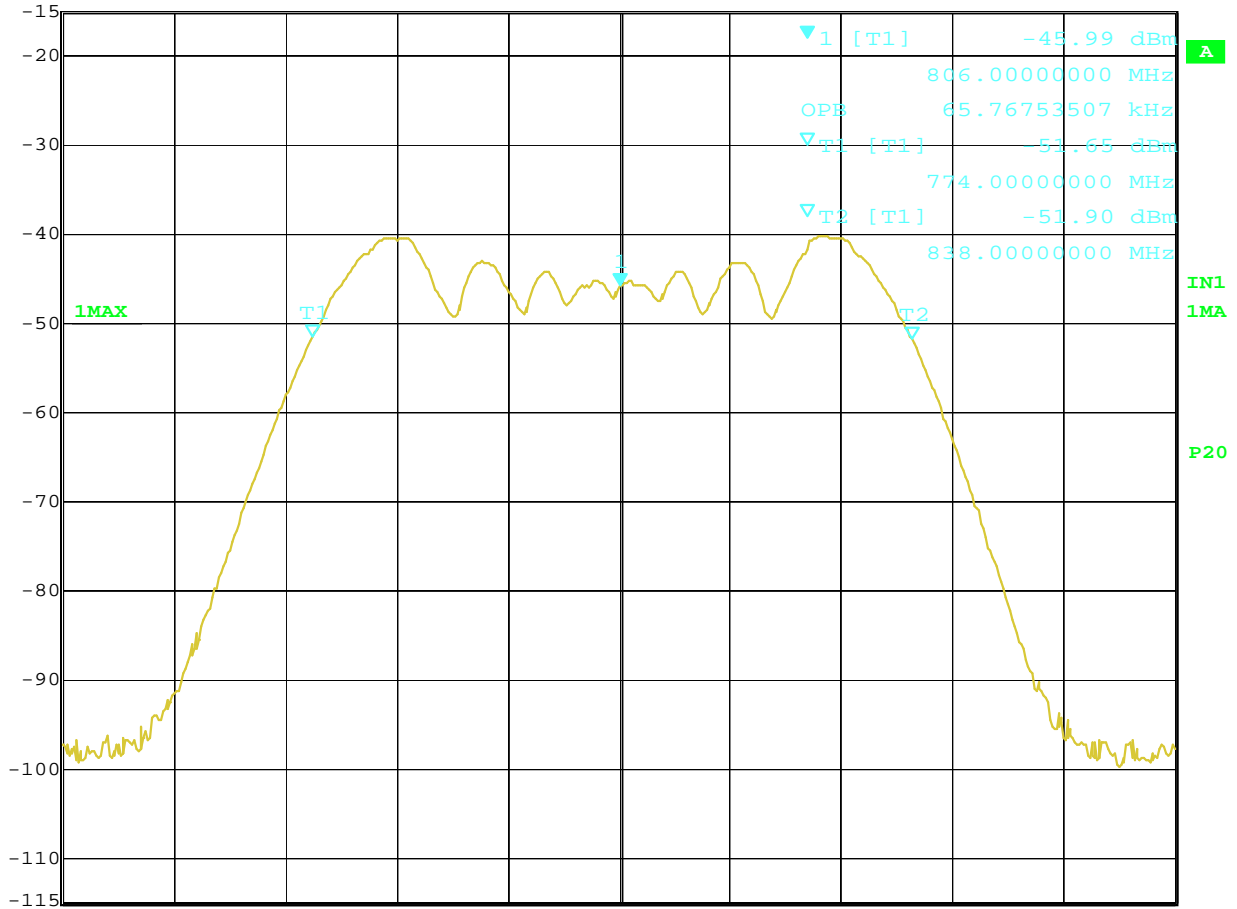

Center 806 MHz 12.2 kHz/ Span 122 kHz

Title: 806MHz With 2500Hz modulation
Comment A: CHIAYO ELECTRONICS CO.,LTD.
Date: 8.SEP.2005 17:49:00



Registration number: W6M20508-6114-C-1
FCC ID: CINSM-6100

Appendix D

Spurious Emissions at Antenna Terminals

(The measurement diagram are wideband pre-scan results; only for reference.)



Marker 1 [T1] RBW 100 kHz RF Att 10 dB
Ref Lvl -65.89 dBm VBW 100 kHz
-7.5 dBm 200.0000000 MHz SWT 2 s Unit dBm

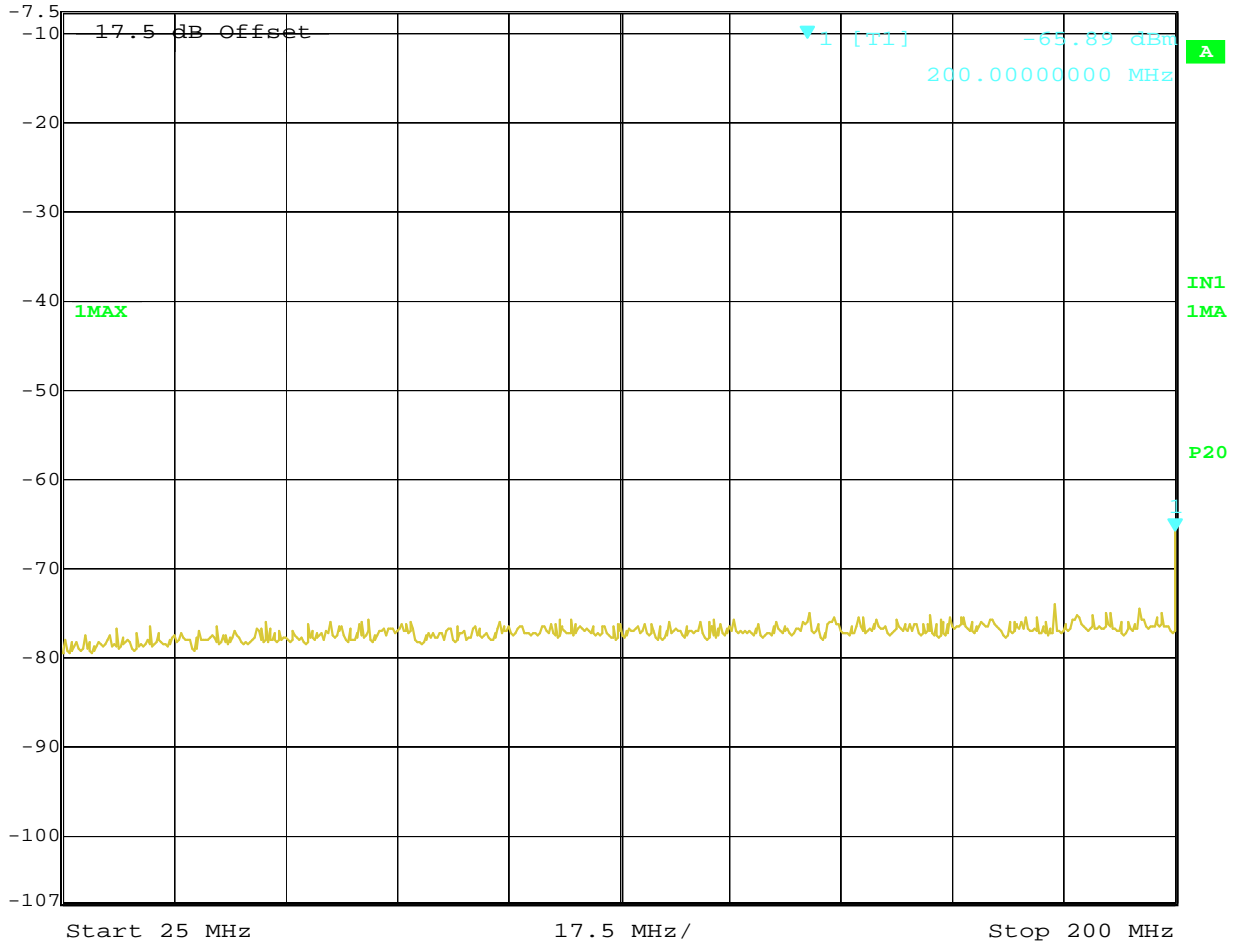

Title: conducted spurious emission
Comment A: CHIAYO ELECTRONICS CO.,LTD.
Date: 8.SEP.2005 18:42:00



Marker 1 [T1] RBW 100 kHz RF Att 30 dB
Ref Lvl 12.5 dBm 0.36 dBm VBW 100 kHz
17.5 dB Offset 614.53046092 MHz SWT 2 s Unit dBm

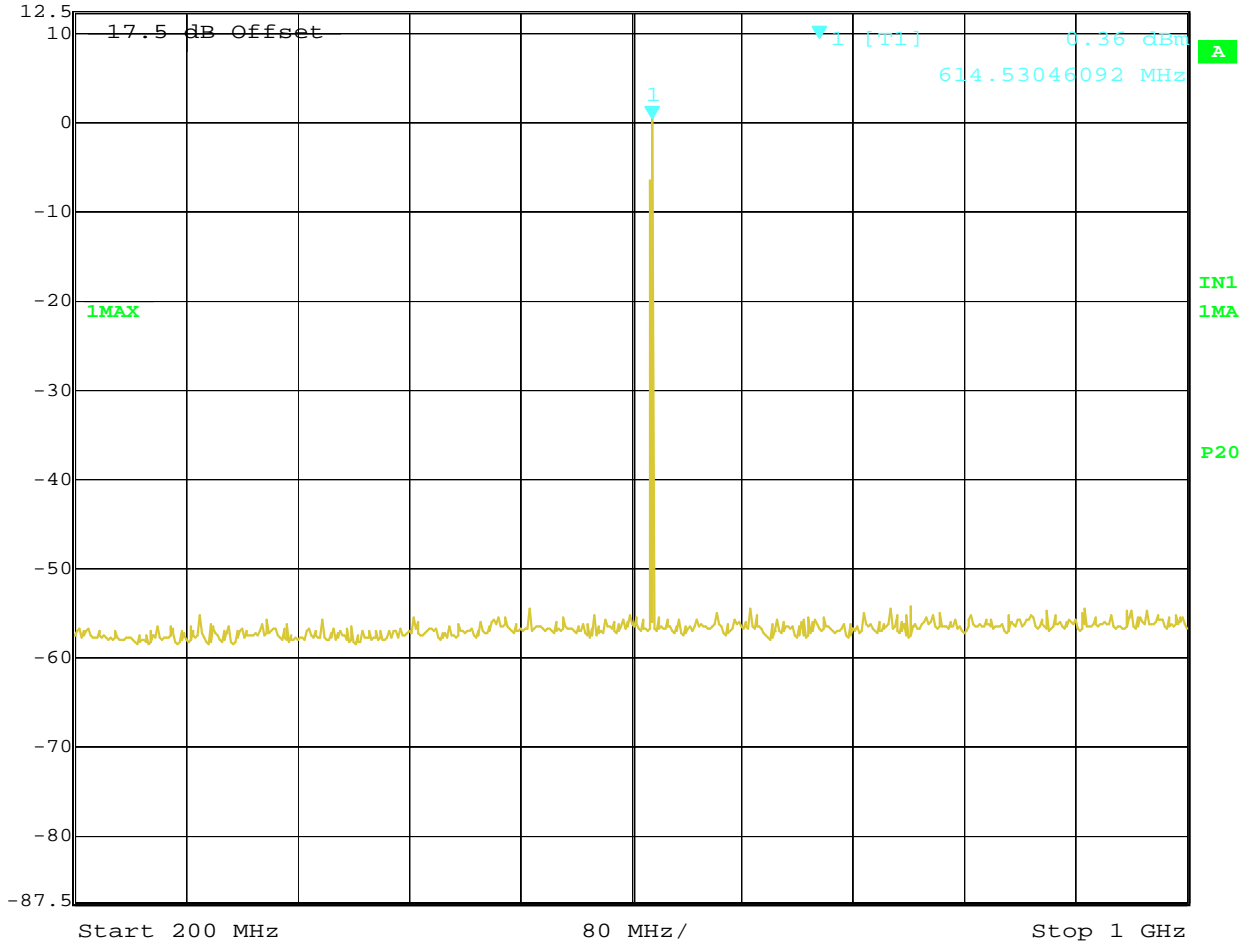

Title: conducted spurious emission
Comment A: CHIAYO ELECTRONICS CO.,LTD.
Date: 8.SEP.2005 18:41:04



Marker 1 [T1] RBW 100 kHz RF Att 10 dB
Ref Lvl -68.99 dBm VBW 100 kHz
-7.5 dBm 1.84168337 GHz SWT 2 s Unit dBm

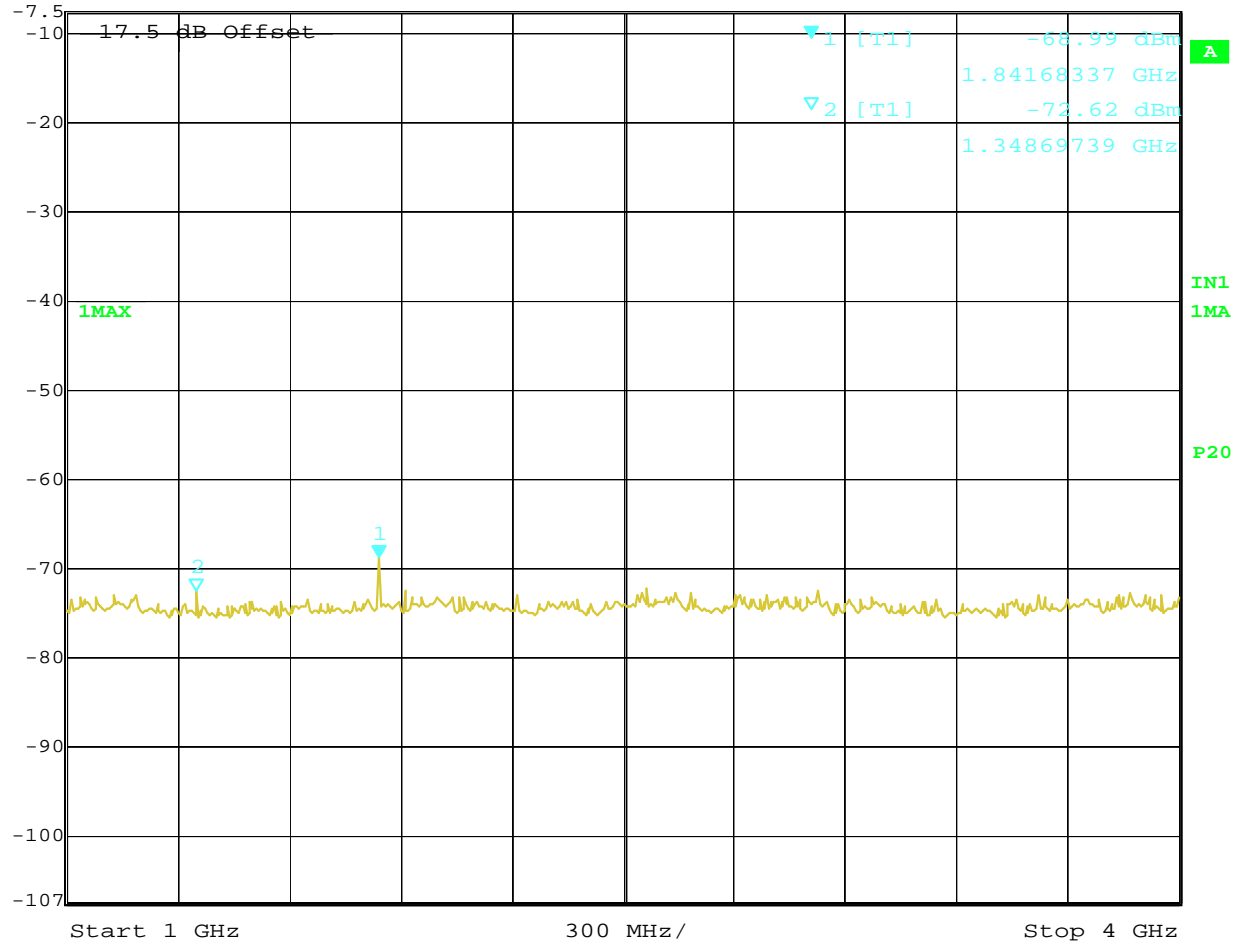

Title: conducted spurious emission
Comment A: CHIAYO ELECTRONICS CO.,LTD.
Date: 8.SEP.2005 18:43:07



Marker 1 [T1] RBW 100 kHz RF Att 10 dB
Ref Lvl -51.62 dBm VBW 100 kHz
-7.5 dBm 6.92585170 GHz SWT 2 s Unit dBm

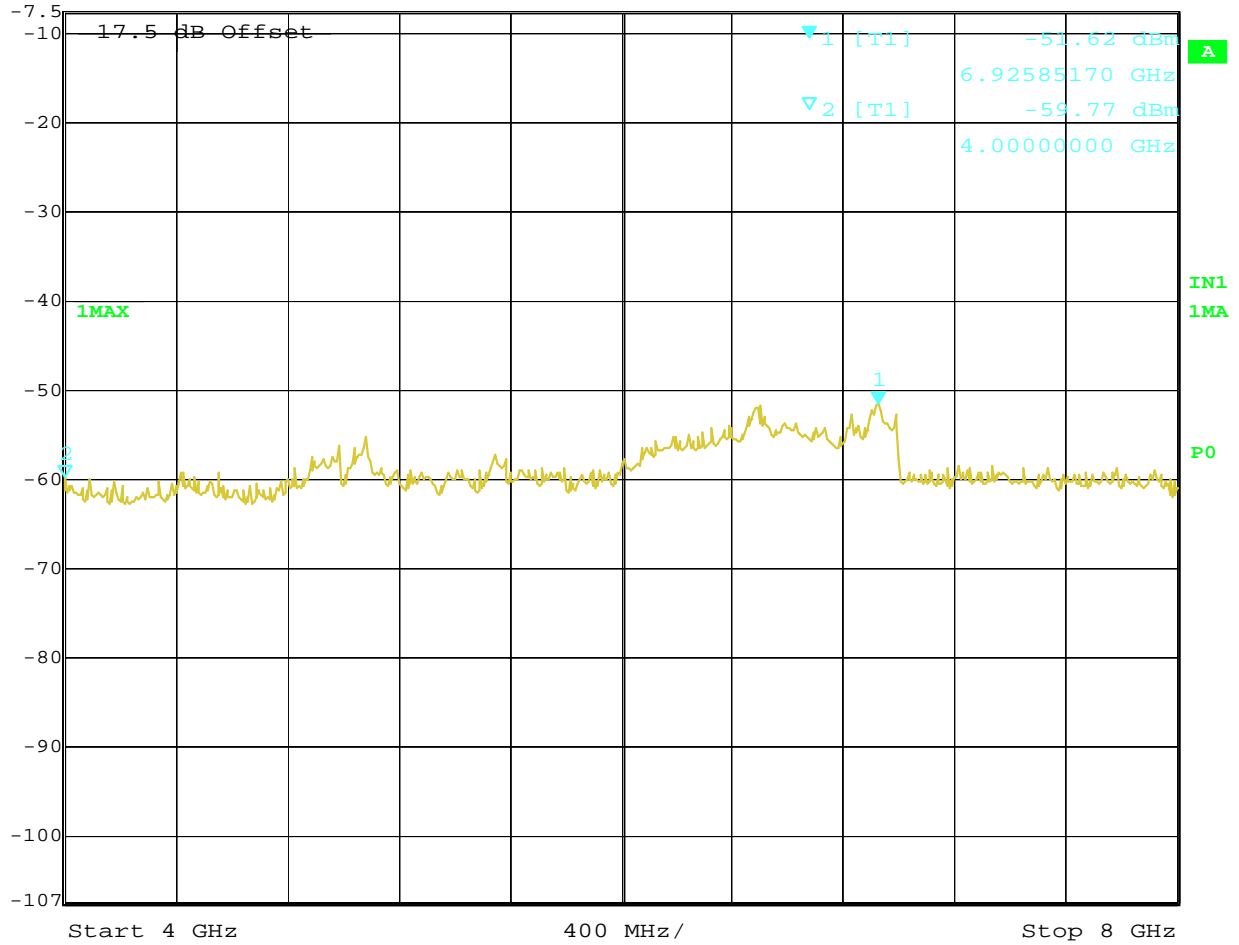

Title: conducted spurious emission
Comment A: CHIAYO ELECTRONICS CO.,LTD.
Date: 8.SEP.2005 18:43:42



Marker 1 [T1] RBW 100 kHz RF Att 10 dB
Ref Lvl -15 dBm -80.58 dBm VBW 100 kHz
200.00000000 MHz SWT 2 s Unit dBm

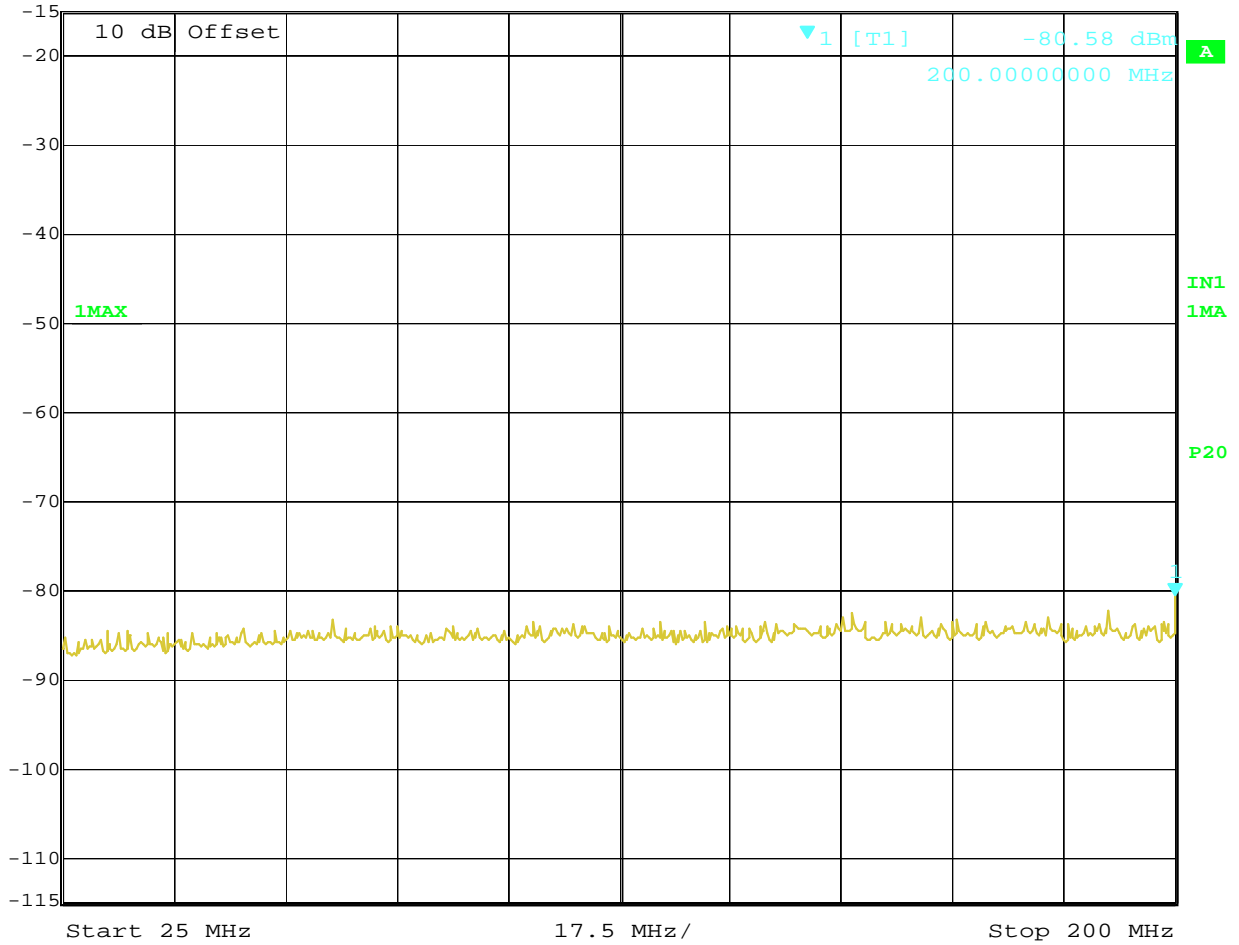

Title: conducted spurious emission
Comment A: CHIAYO ELECTRONICS CO.,LTD.
Date: 8.SEP.2005 18:26:09



Marker 1 [T1] RBW 100 kHz RF Att 30 dB
Ref Lvl -2.47 dBm VBW 100 kHz
5 dBm 710.20040080 MHz SWT 2 s Unit dBm

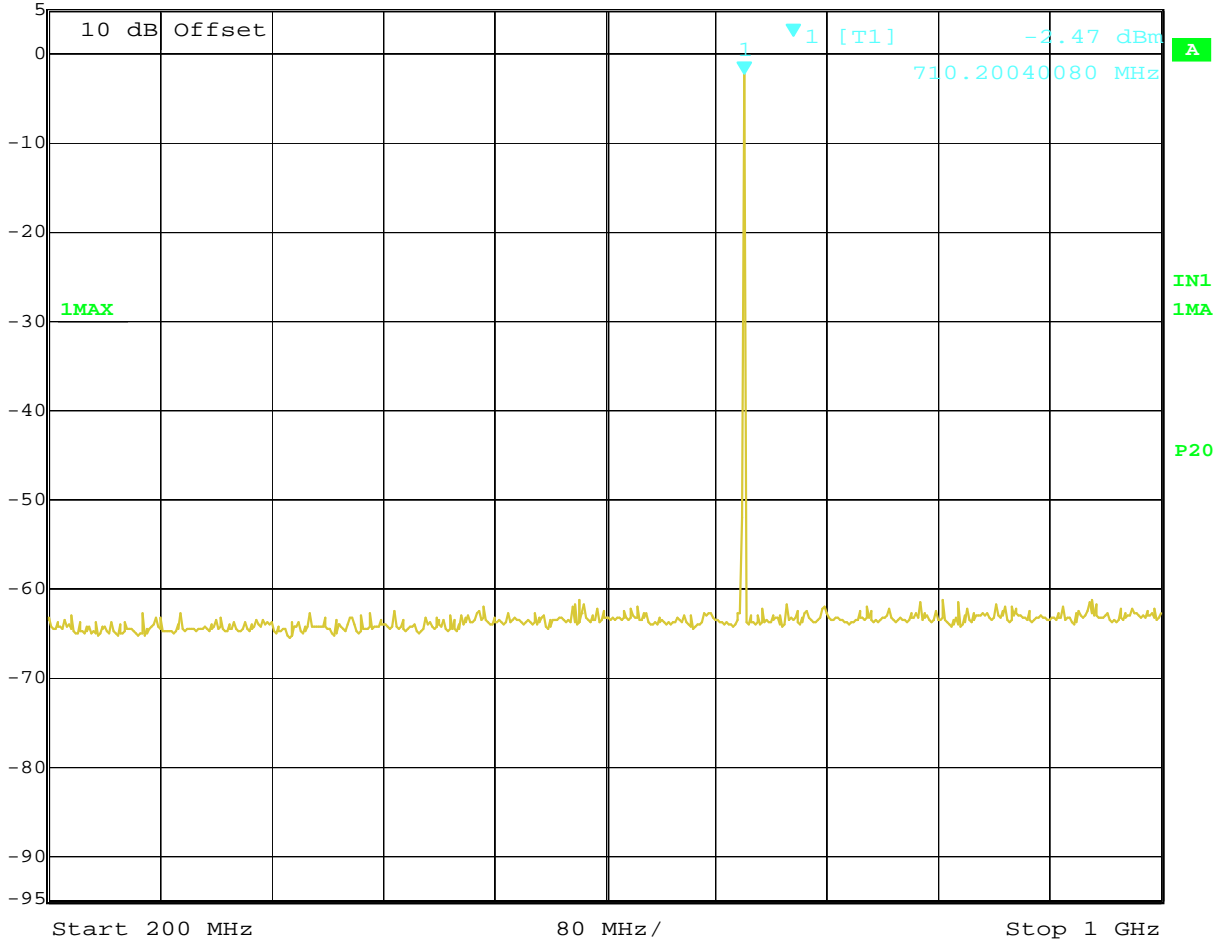

Title: conducted spurious emission
Comment A: CHIAYO ELECTRONICS CO.,LTD.
Date: 8.SEP.2005 18:20:22



Marker 1 [T1] RBW 100 kHz RF Att 10 dB
Ref Lvl -73.71 dBm VBW 100 kHz
-15 dBm 1.39679359 GHz SWT 2 s Unit dBm

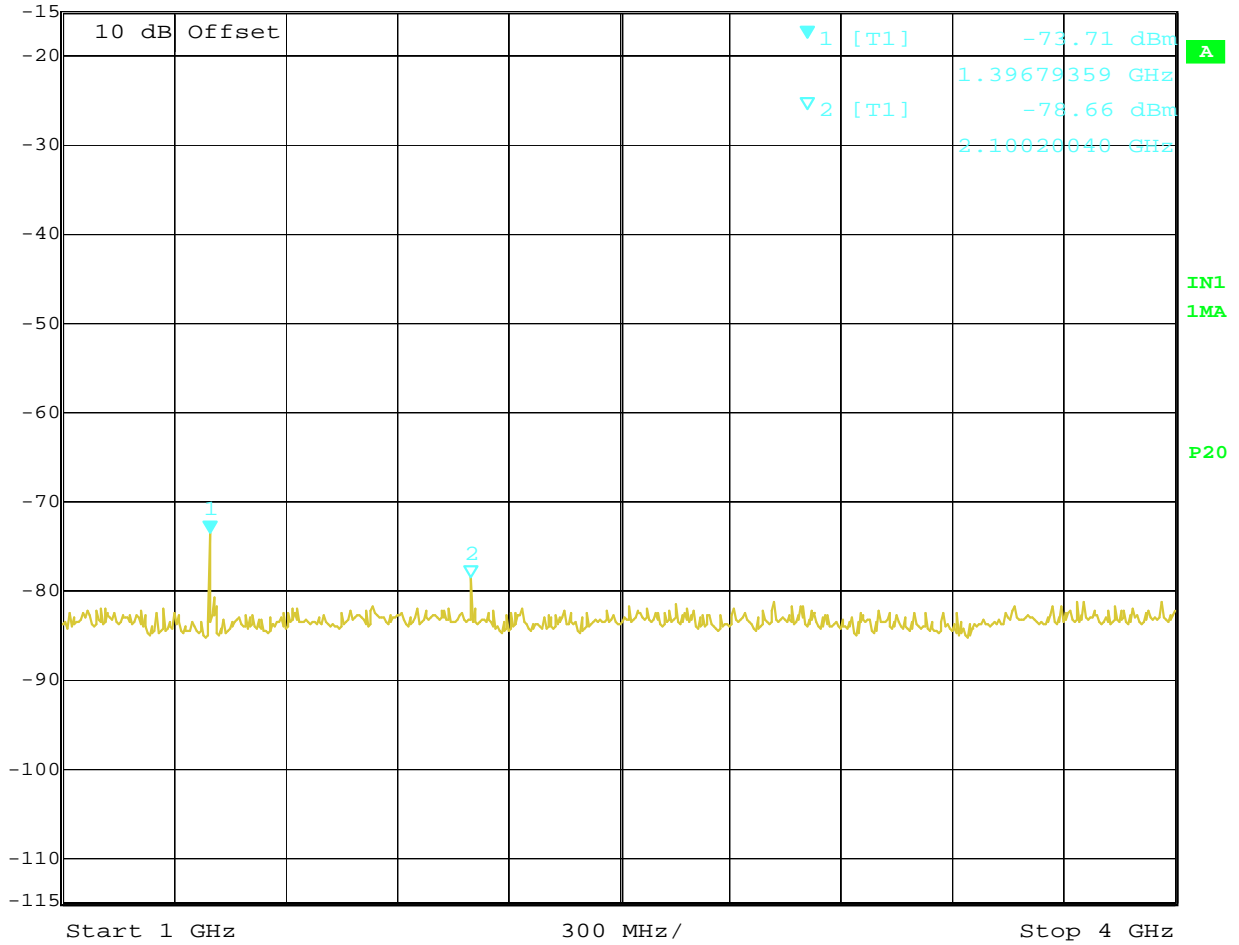

Title: conducted spurious emission
Comment A: CHIAYO ELECTRONICS CO.,LTD.
Date: 8.SEP.2005 18:25:05



Marker 1 [T1] RBW 100 kHz RF Att 10 dB
Ref Lvl -57.19 dBm VBW 100 kHz
5 dBm 6.49298597 GHz SWT 2 s Unit dBm

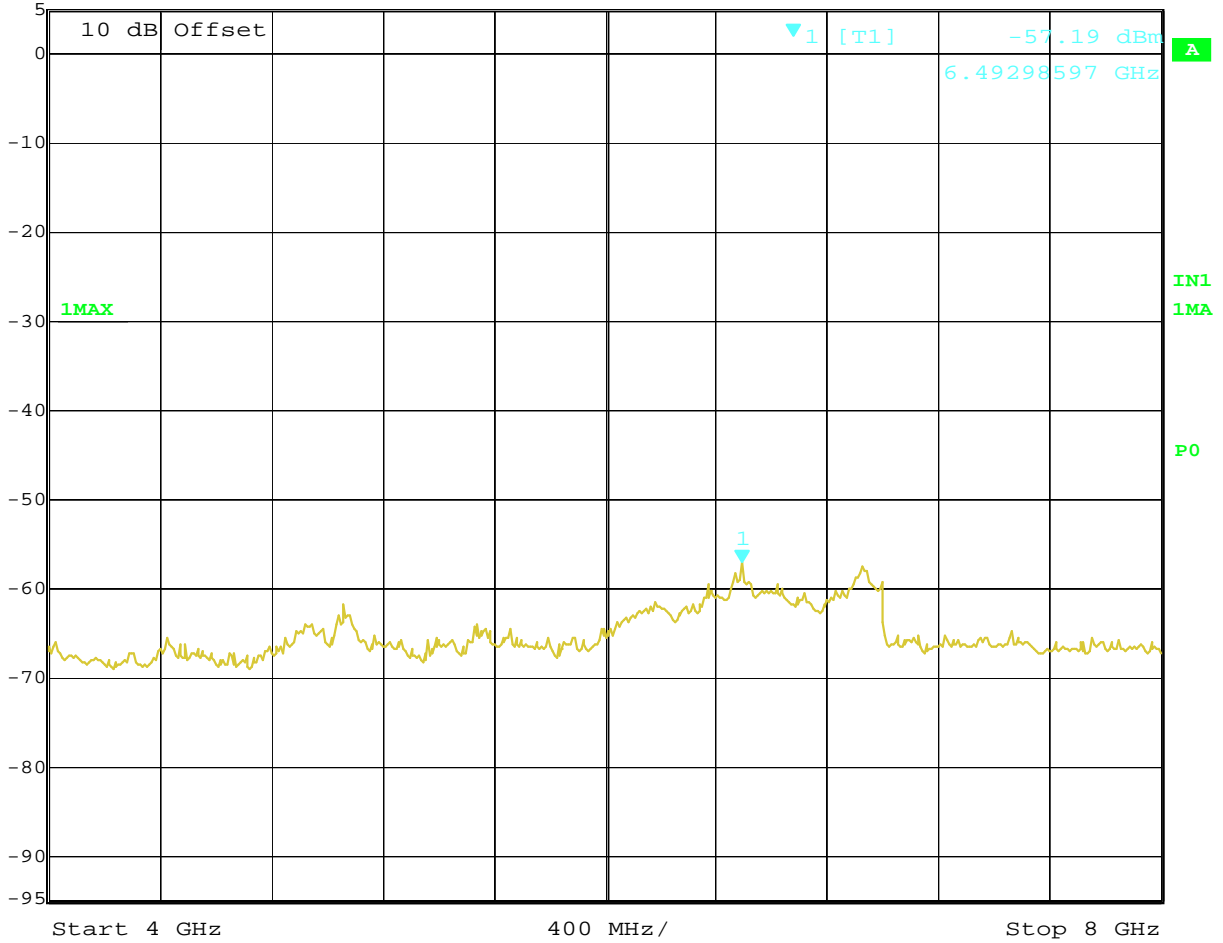

Title: conducted spurious emission
Comment A: CHIAYO ELECTRONICS CO.,LTD.
Date: 8.SEP.2005 18:23:27



Marker 1 [T1] RBW 100 kHz RF Att 10 dB
Ref Lvl -67.20 dBm VBW 100 kHz
-0.5 dBm 200.00000000 MHz SWT 2 s Unit dBm

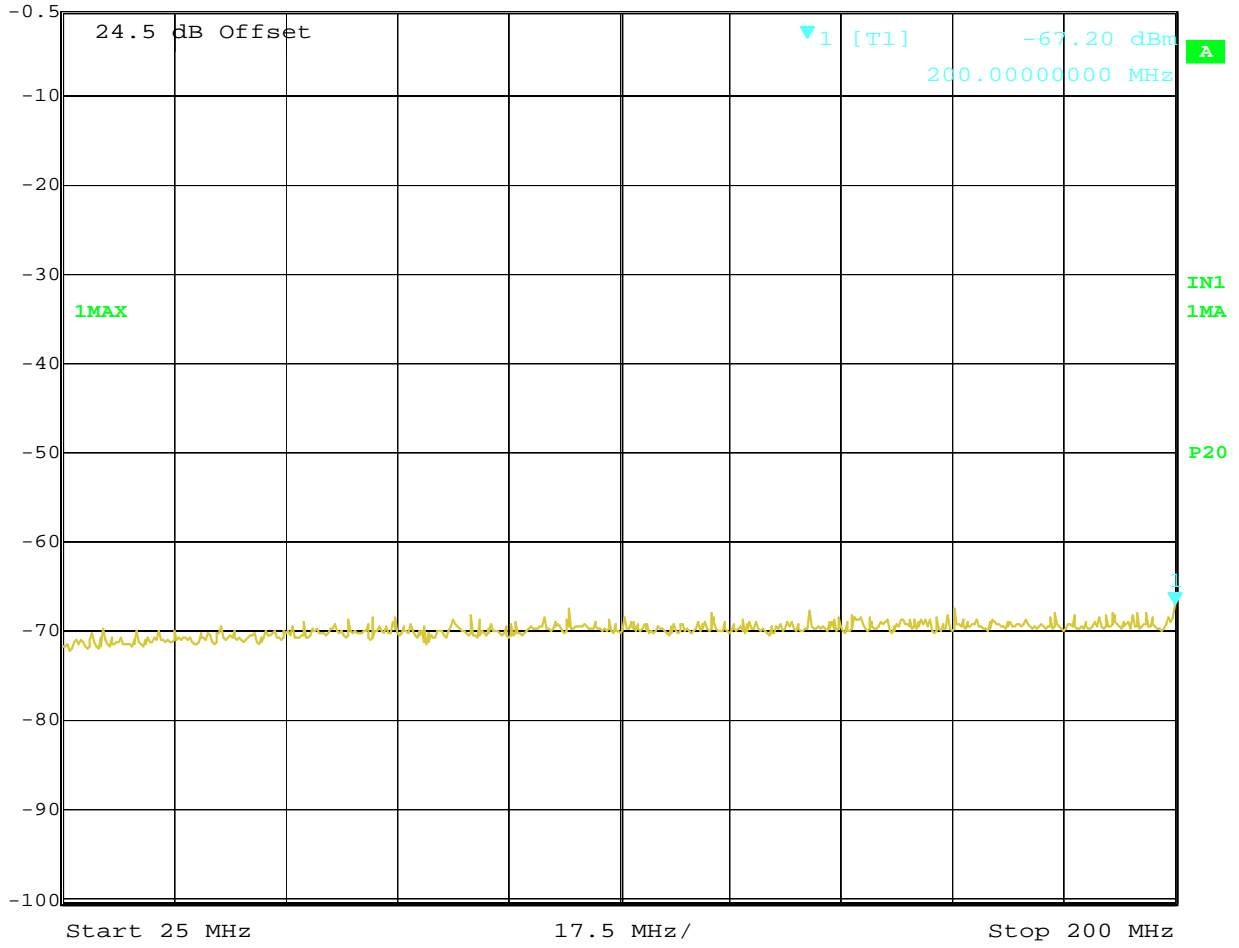

Title: conducted spurious emission
Comment A: CHIAYO ELECTRONICS CO.,LTD.
Date: 8.SEP.2005 18:32:31



Ref Lvl
15 dBm

7.97 dBm
805.96392786 MHz

RBW 100 kHz RF Att 30 dB
VBW 100 kHz
SWT 2 s Unit dBm

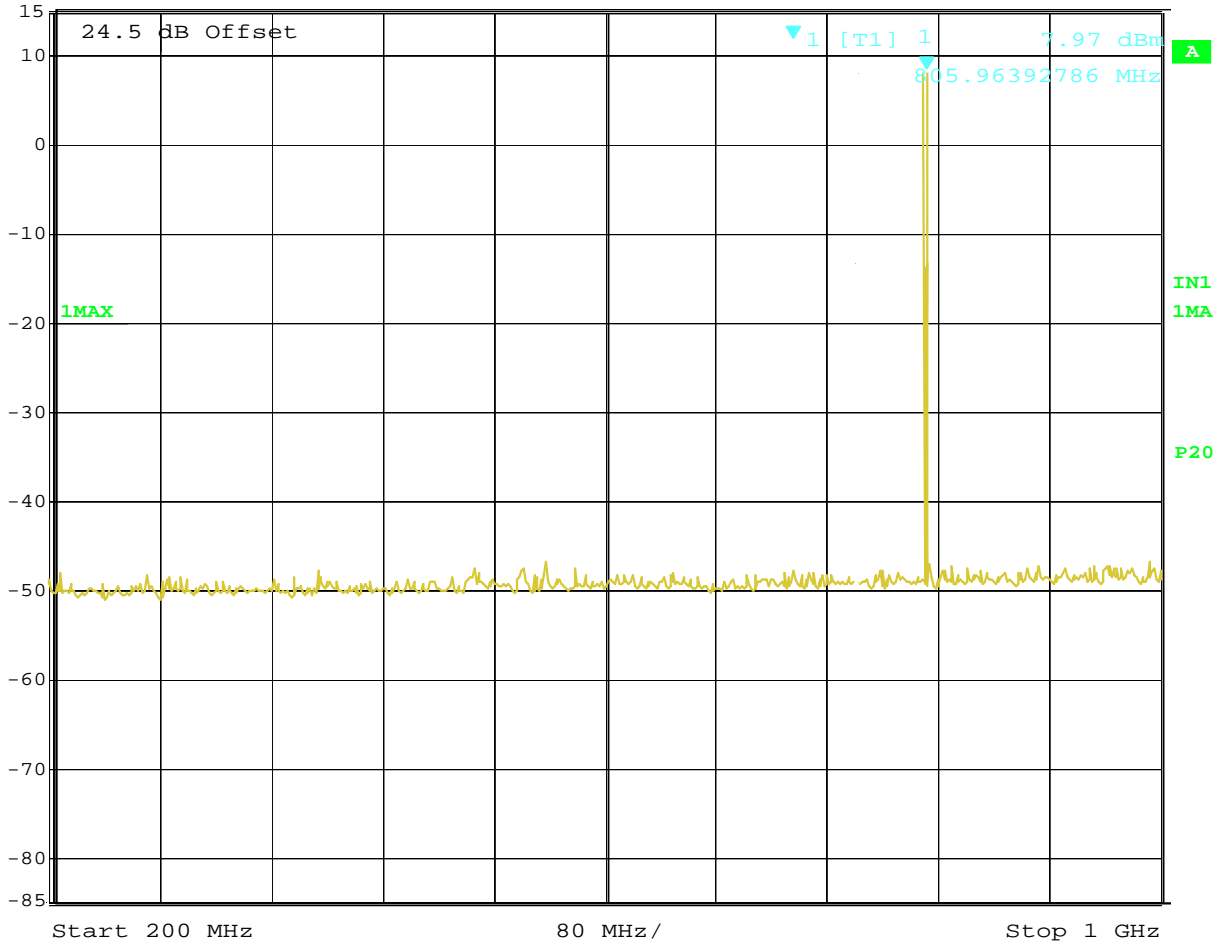

Title: conducted spurious emission
Comment A: CHIAYO ELECTRONICS CO.,LTD.
Date: 8.SEP.2005 19:06:15



Marker 1 [T1] RBW 100 kHz RF Att 10 dB
Ref Lvl -50.46 dBm VBW 100 kHz
-0.5 dBm 1.55911824 GHz SWT 2 s Unit dBm

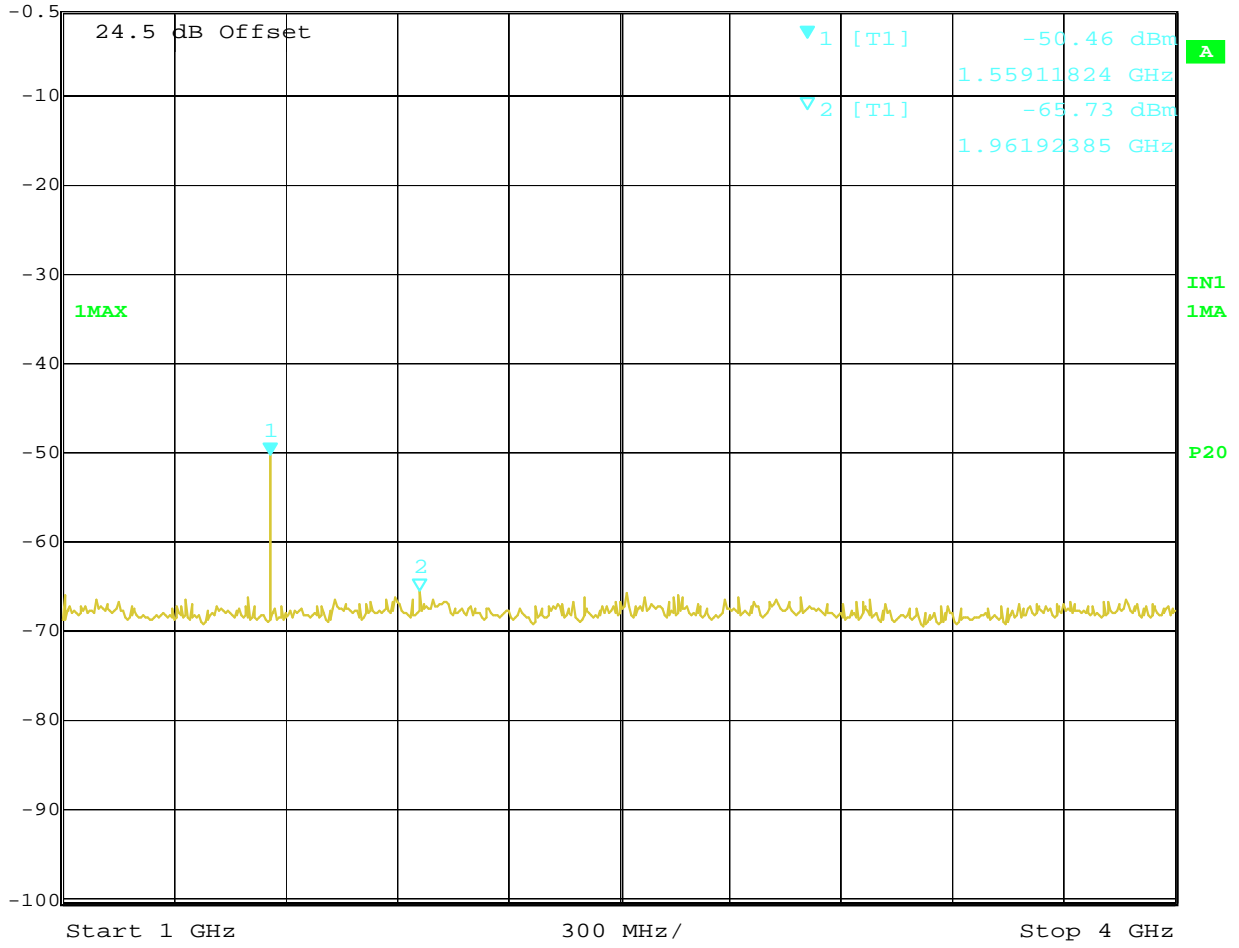

Title: conducted spurious emission
Comment A: CHIAYO ELECTRONICS CO.,LTD.
Date: 8.SEP.2005 18:33:21



Marker 1 [T1] RBW 100 kHz RF Att 10 dB
Ref Lvl -44.16 dBm VBW 100 kHz
-0.5 dBm 6.92585170 GHz SWT 2 s Unit dBm

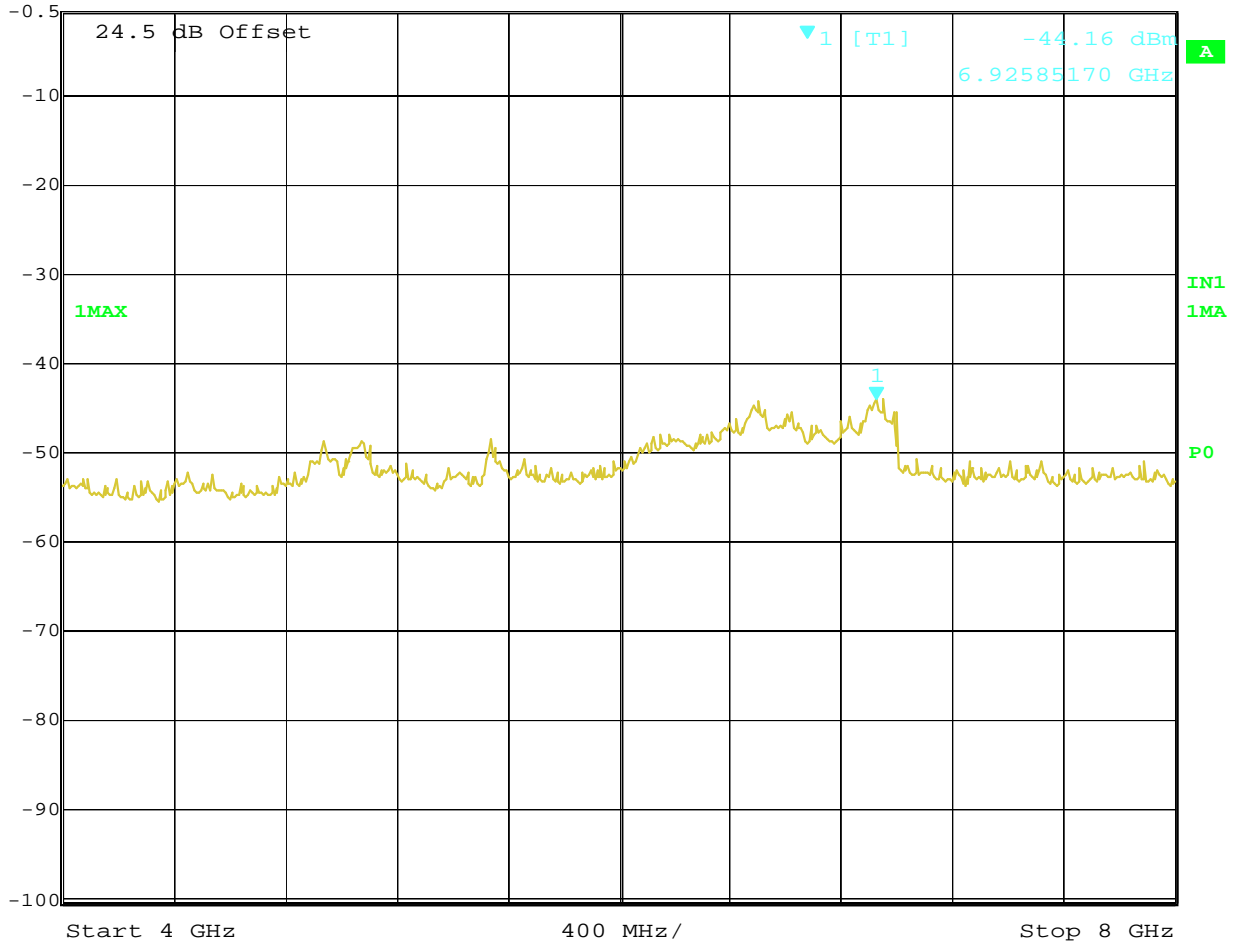

Title: conducted spurious emission
Comment A: CHIAYO ELECTRONICS CO.,LTD.
Date: 8.SEP.2005 18:34:05

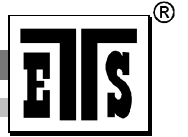

Registration number: W6M20508-6114-C-1
FCC ID: CINSM-6100

Appendix E

Radiation Spurious Emission

(The measurement diagram are wideband pre-scan results; only for reference.)

Spurious emissions under normal conditions

in according to FCC Part 74.861

EUT: Wireless Microphone
MODEL NO.: SM-6100 614.5MHz
Approval Holder: CHIAYO ELECTRONICS CO.,LTD.
Test Site / Operator: ETS / Mike Wu
Temperature/Voltage: Temp.: 23°C/ Unom.: 3 VDC (1.5V Battery x 2)
Test Specification: 74.861
Comment 1: Dist.: 3m, Ant.: HK 116
Freq:195.090MHz Pmax:-56.19dBm RBW: 100 kHz

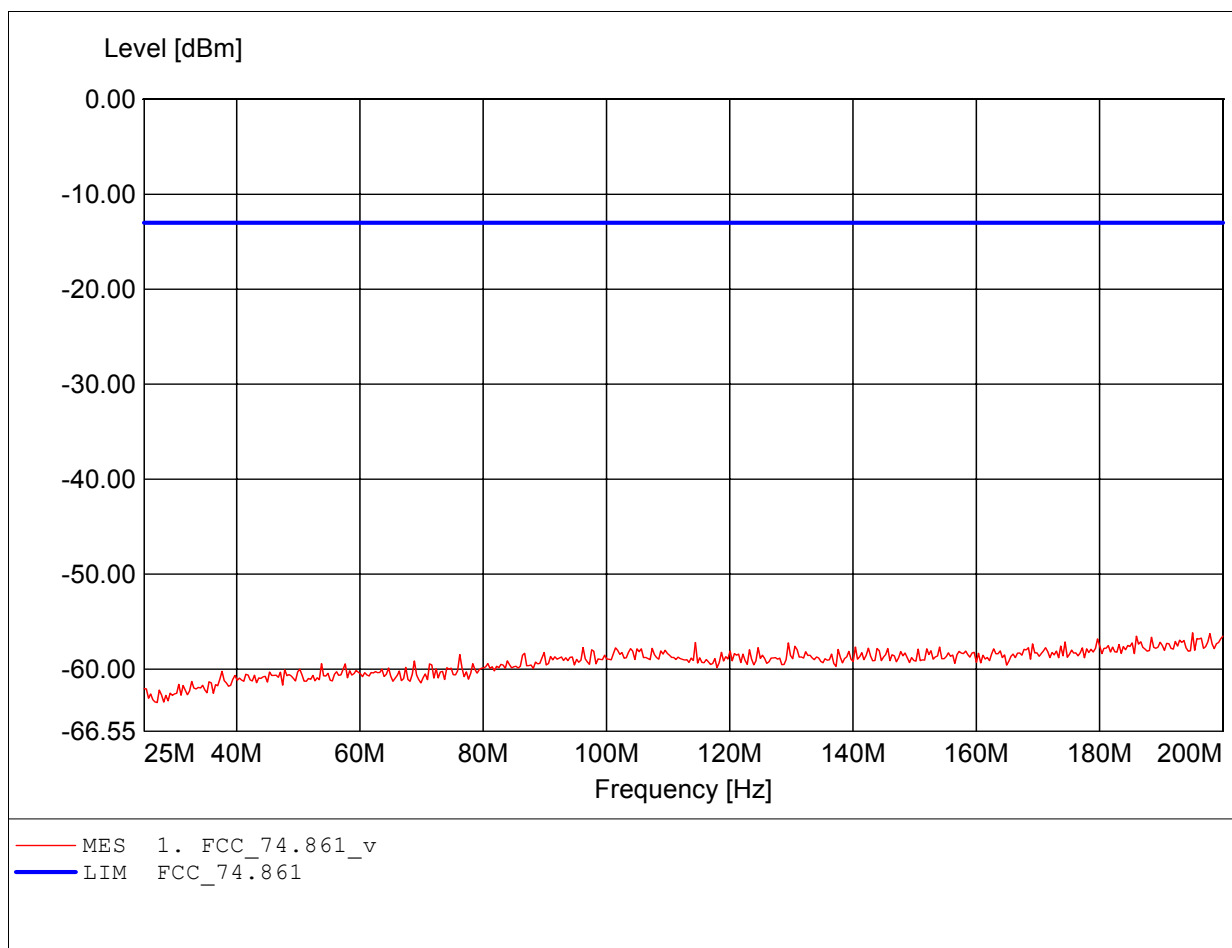

Spurious emissions under normal conditions

in according to FCC Part 74.861

EUT: Wireless Microphone
MODEL NO.: SM-6100 614.5MHz
Approval Holder: CHIAYO ELECTRONICS CO.,LTD.
Test Site / Operator: ETS / Mike Wu
Temperature/Voltage: Temp.: 23°C/ Unom.: 3 VDC (1.5V Battery x 2)
Test Specification: 74.861
Comment 1: Dist.: 3m, Ant.: HK 116
Freq:196.844MHz Pmax:-57.06dBm RBW: 100 kHz

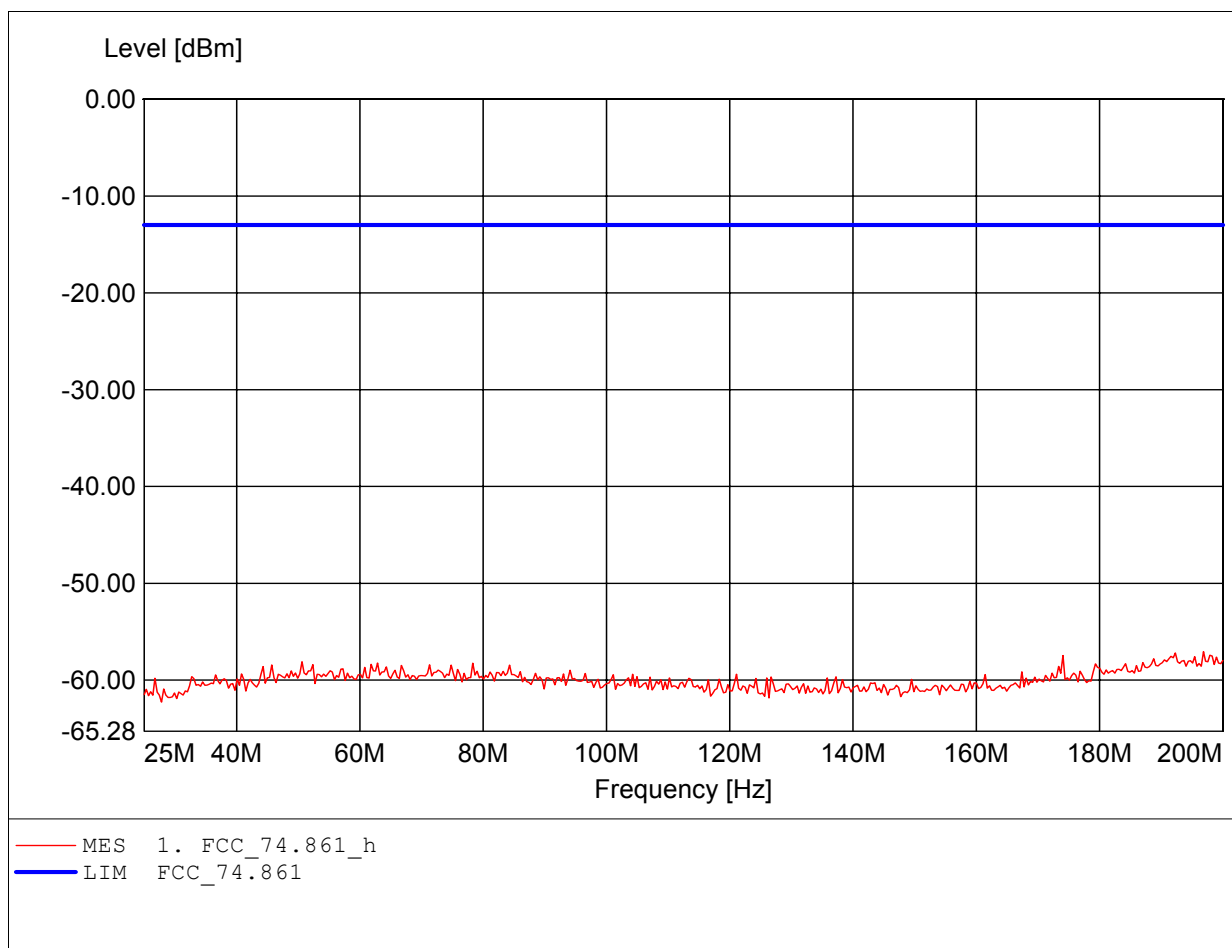

Spurious emissions under normal conditions

in according to FCC Part 74.861

EUT: Wireless Microphone
MODEL NO.: SM-6100 614.5MHz
Approval Holder: CHIAYO ELECTRONICS CO.,LTD.
Test Site / Operator: ETS / Mike Wu
Temperature/Voltage: Temp.: 23°C/ Unom.: 3 VDC (1.5V Battery x 2)
Test Specification: 74.861
Comment 1: Dist.: 3m, Ant.: HL 223, ampl.: 0.1-1GHz
Freq:974.349MHz Pmax:-68.58dBm RBW: 100 kHz

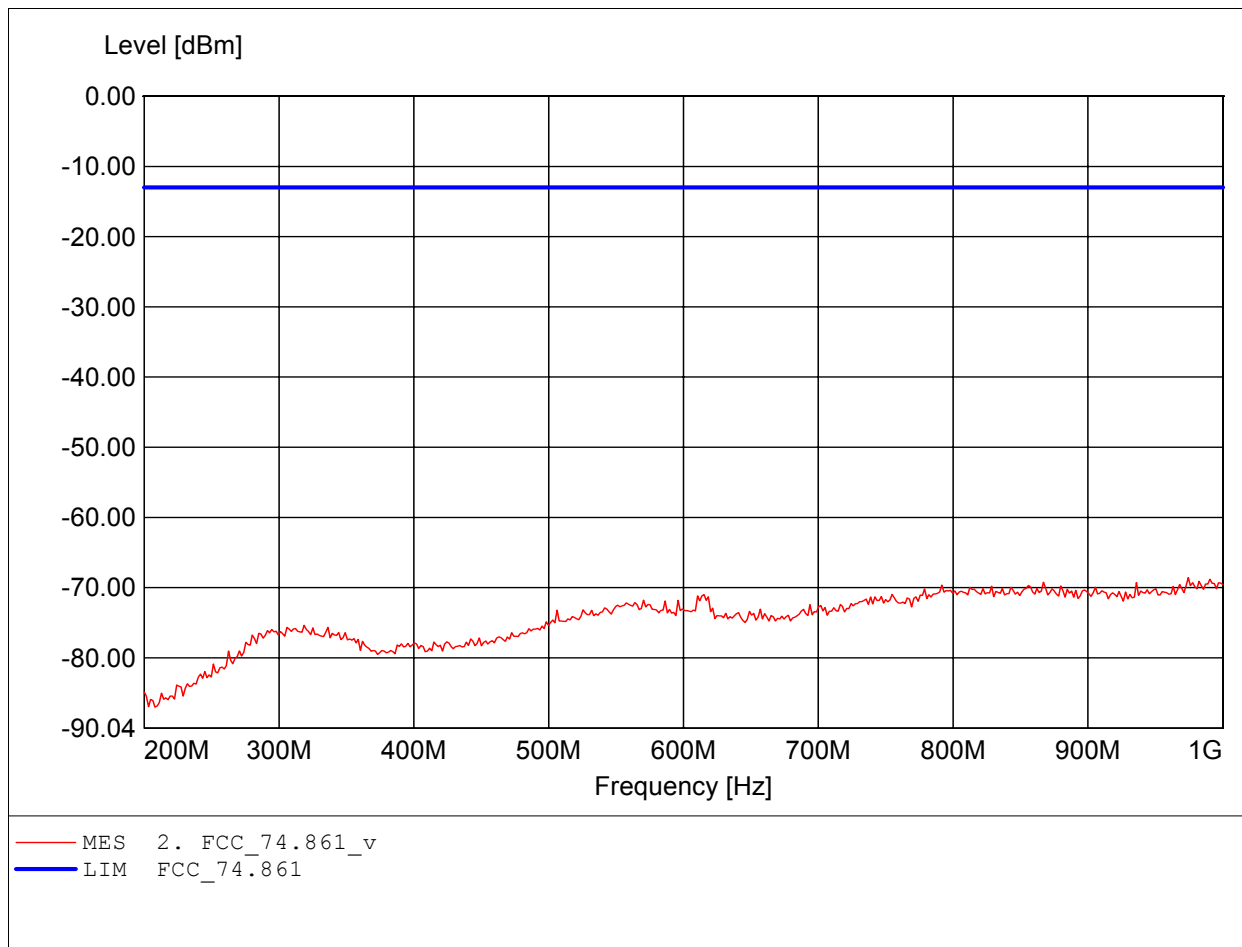

Spurious emissions under normal conditions

in according to FCC Part 74.861

EUT: Wireless Microphone
MODEL NO.: SM-6100 614.5MHz
Approval Holder: CHIAYO ELECTRONICS CO.,LTD.
Test Site / Operator: ETS / Mike Wu
Temperature/Voltage: Temp.: 23°C/ Unom.: 3 VDC (1.5V Battery x 2)
Test Specification: 74.861
Comment 1: Dist.: 3m, Ant.: HL 223, ampl.: 0.1-1GHz
Freq:963.126MHz Pmax:-68.05dBm RBW: 100 kHz

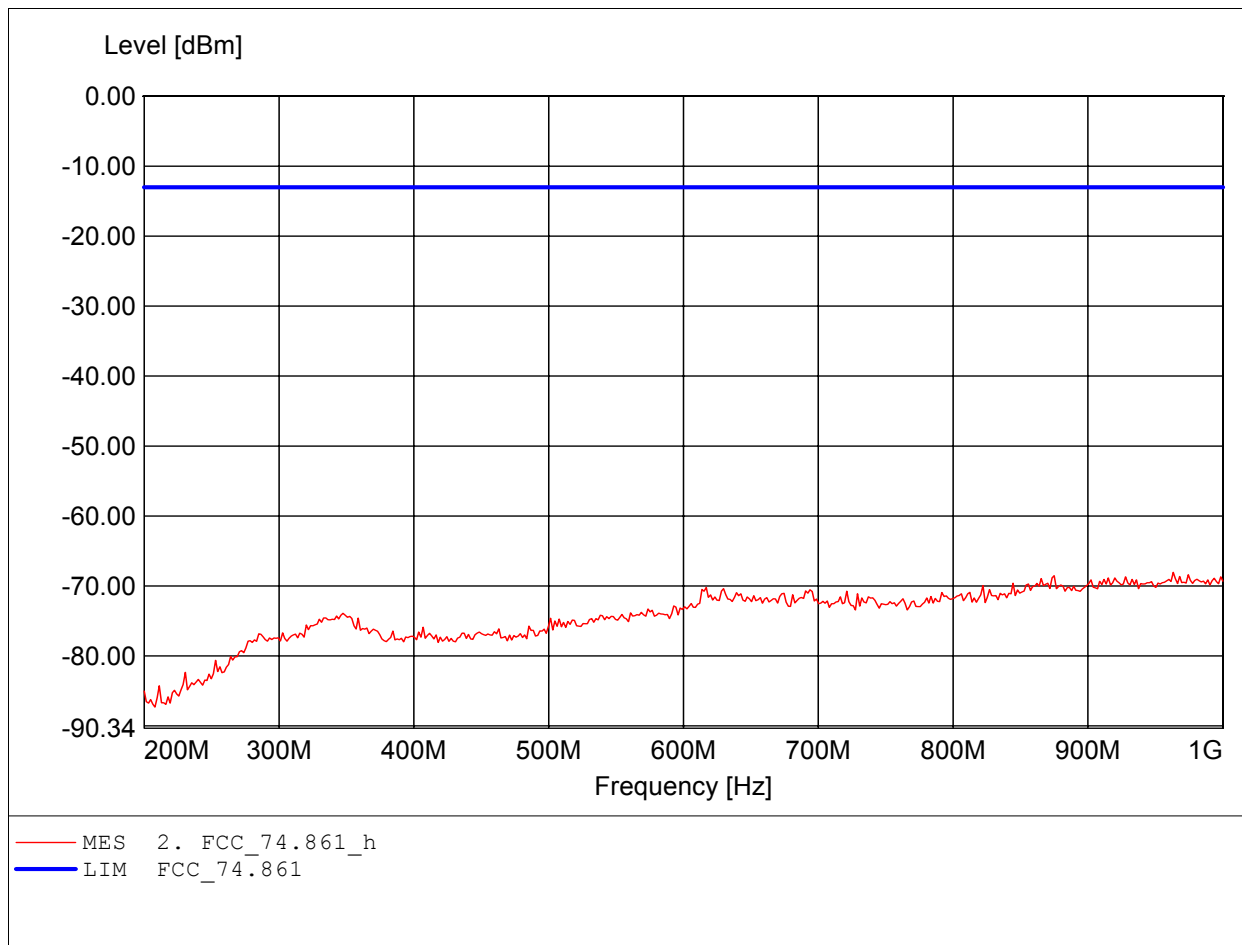

Spurious emissions under normal conditions

in according to FCC Part 74.861

EUT: Wireless Microphone
MODEL NO.: SM-6100 614.5MHz
Approval Holder: CHIAYO ELECTRONICS CO.,LTD.
Test Site / Operator: ETS / Mike Wu
Temperature/Voltage: Temp.: 23°C/ Unom.: 3 VDC (1.5V Battery x 2)
Test Specification: 74.861
Comment 1: Dist.: 3m, Ant.: HL 025, ampl.: 1-4GHz
Freq:3.555GHz Pmax:-49.51dBm RBW: 1 MHz

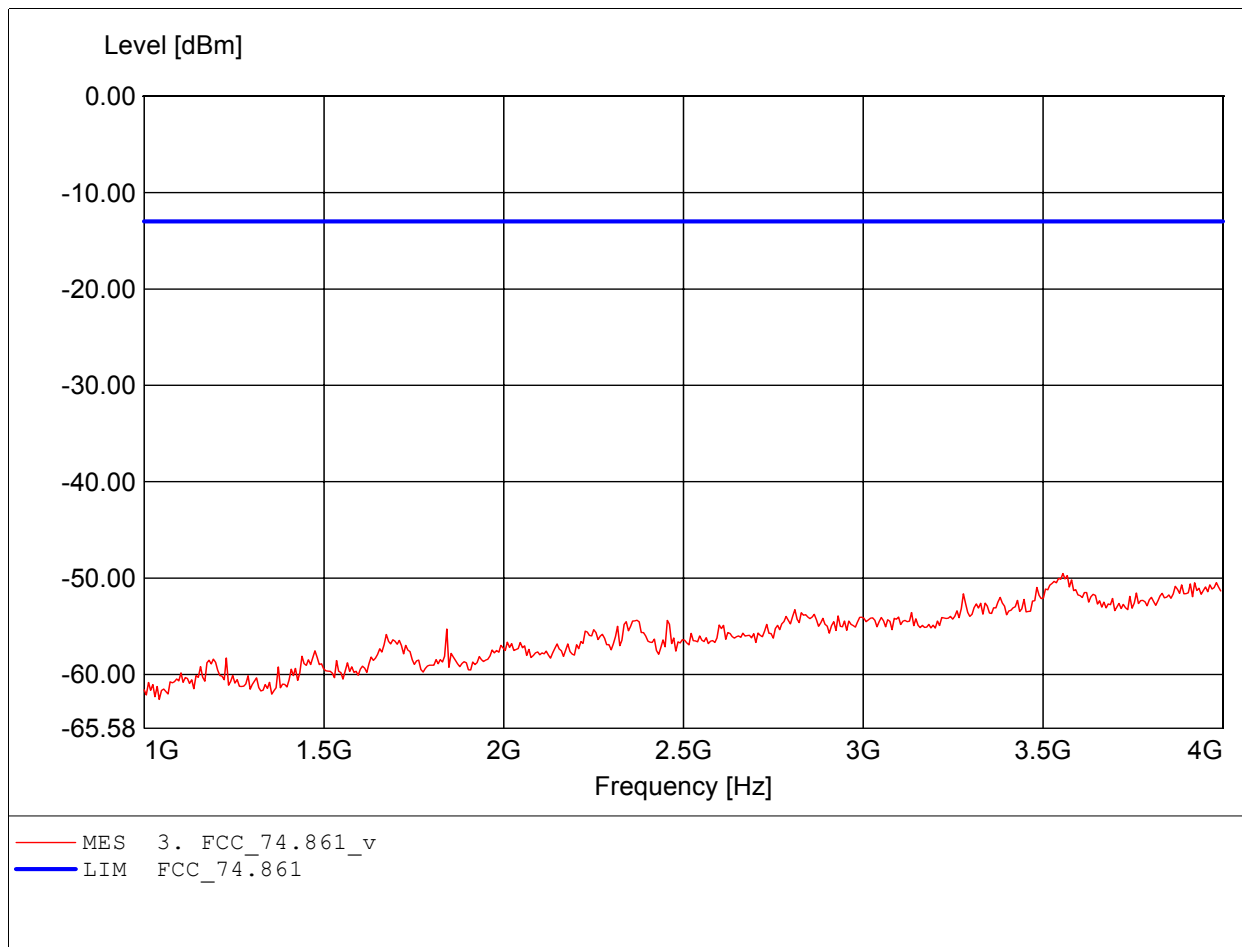

Spurious emissions under normal conditions

in according to FCC Part 74.861

EUT: Wireless Microphone
MODEL NO.: SM-6100 614.5MHz
Approval Holder: CHIAYO ELECTRONICS CO.,LTD.
Test Site / Operator: ETS / Mike Wu
Temperature/Voltage: Temp.: 23°C/ Unom.: 3 VDC (1.5V Battery x 2)
Test Specification: 74.861
Comment 1: Dist.: 3m, Ant.: HL 025, ampl.: 1-4GHz
Freq:3.555GHz Pmax:-49.09dBm RBW: 1 MHz

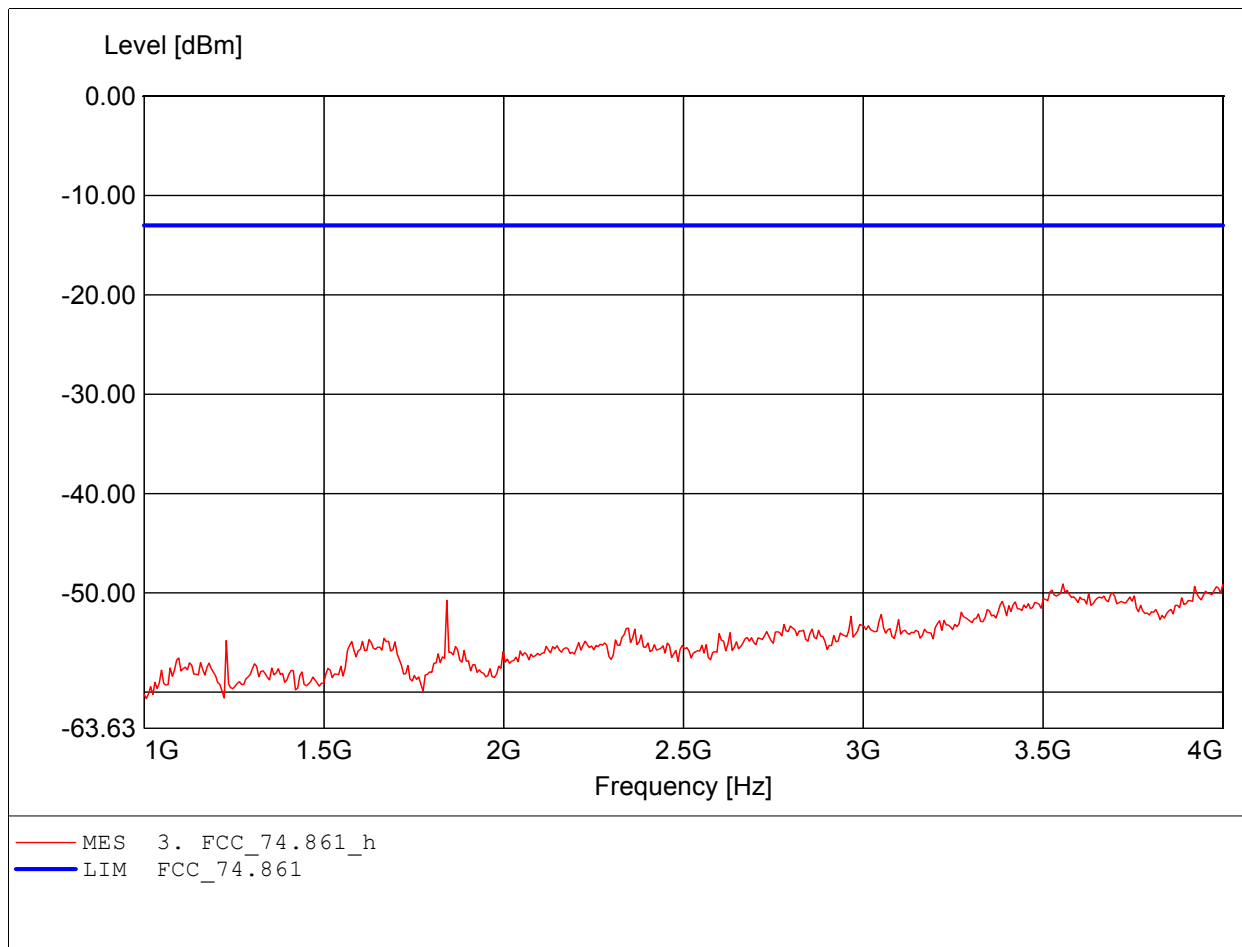

Spurious emissions under normal conditions

in according to FCC Part 74.861

EUT: Wireless Microphone
MODEL NO.: SM-6100 614.5MHz
Approval Holder: CHIAYO ELECTRONICS CO.,LTD.
Test Site / Operator: ETS / Mike Wu
Temperature/Voltage: Temp.: 23°C/ Unom.: 3 VDC (1.5V Battery x 2)
Test Specification: 74.861
Comment 1: Dist.: 3m, Ant.: HL 025, ampl.: 4-8GHz
Freq:7.535GHz Pmax:-43.25dBm RBW: 1 MHz

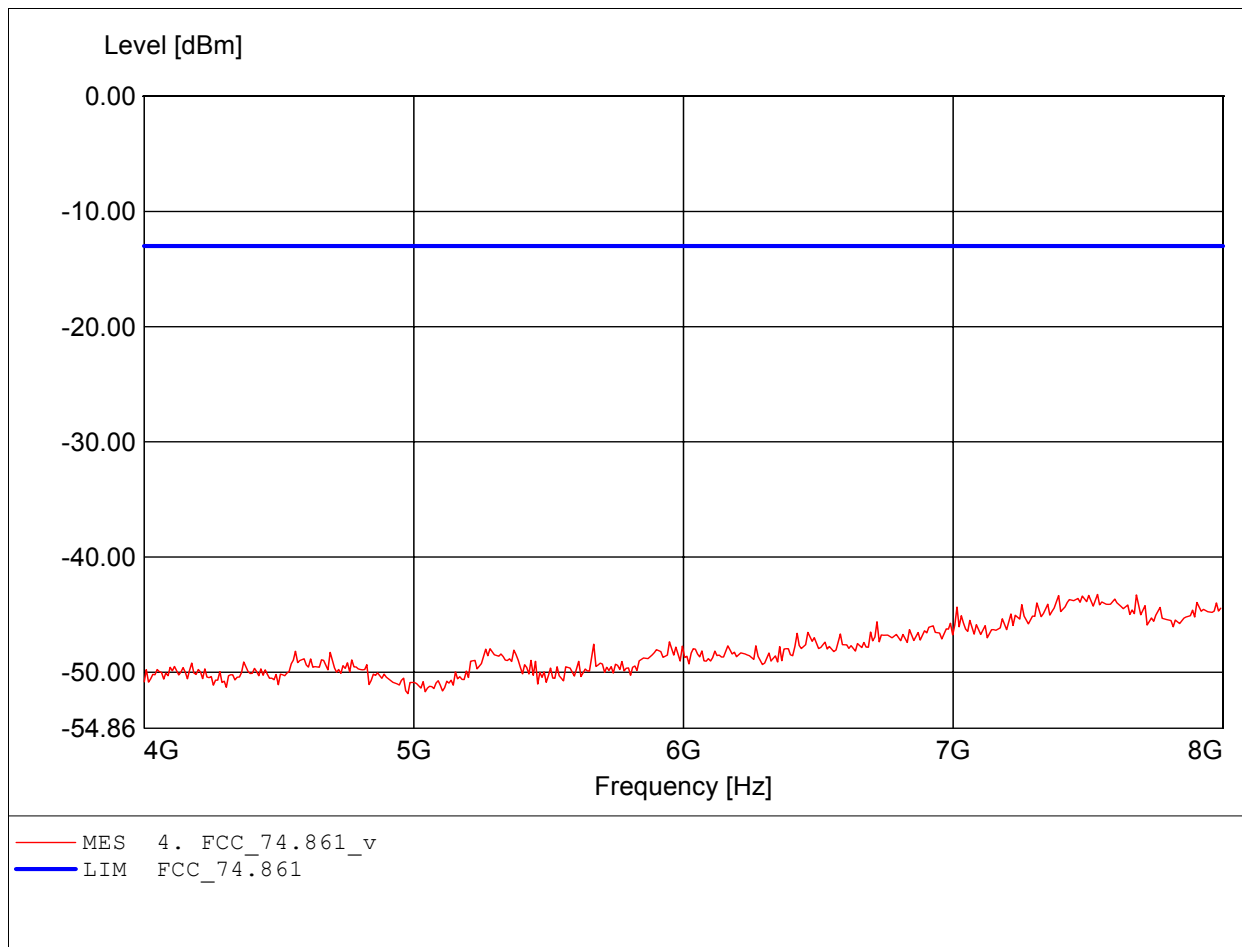

Spurious emissions under normal conditions

in according to FCC Part 74.861

EUT: Wireless Microphone
MODEL NO.: SM-6100 614.5MHz
Approval Holder: CHIAYO ELECTRONICS CO.,LTD.
Test Site / Operator: ETS / Mike Wu
Temperature/Voltage: Temp.: 23°C/ Unom.: 3 VDC (1.5V Battery x 2)
Test Specification: 74.861
Comment 1: Dist.: 3m, Ant.: HL 025, ampl.: 4-8GHz
Freq:7.511GHz Pmax:-42.07dBm RBW: 1 MHz

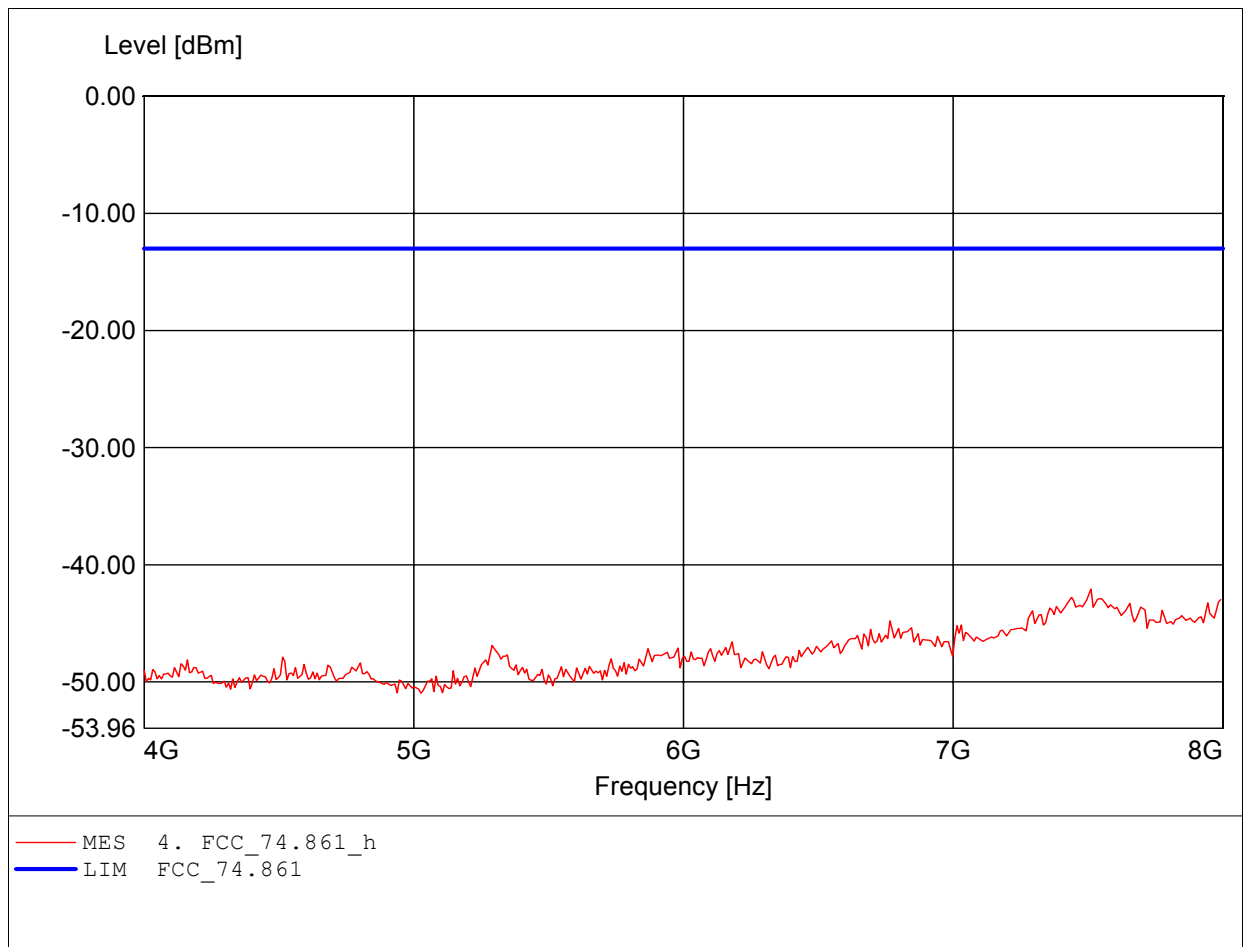

Spurious emissions under normal conditions

in according to FCC Part 74.861

EUT: Wireless Microphone
MODEL NO.: SM-6100 614.5MHz
Approval Holder: CHIAYO ELECTRONICS CO.,LTD.
Test Site / Operator: ETS / Mike Wu
Temperature/Voltage: Temp.: 23°C/ Unom.: 3 VDC (1.5V Battery x 2)
Test Specification: 74.861
Comment 1: Dist.: 3m, Ant.: HL 025, ampl.: 8-18GHz
Freq:12.188GHz Pmax:-34.39dBm RBW: 1 MHz

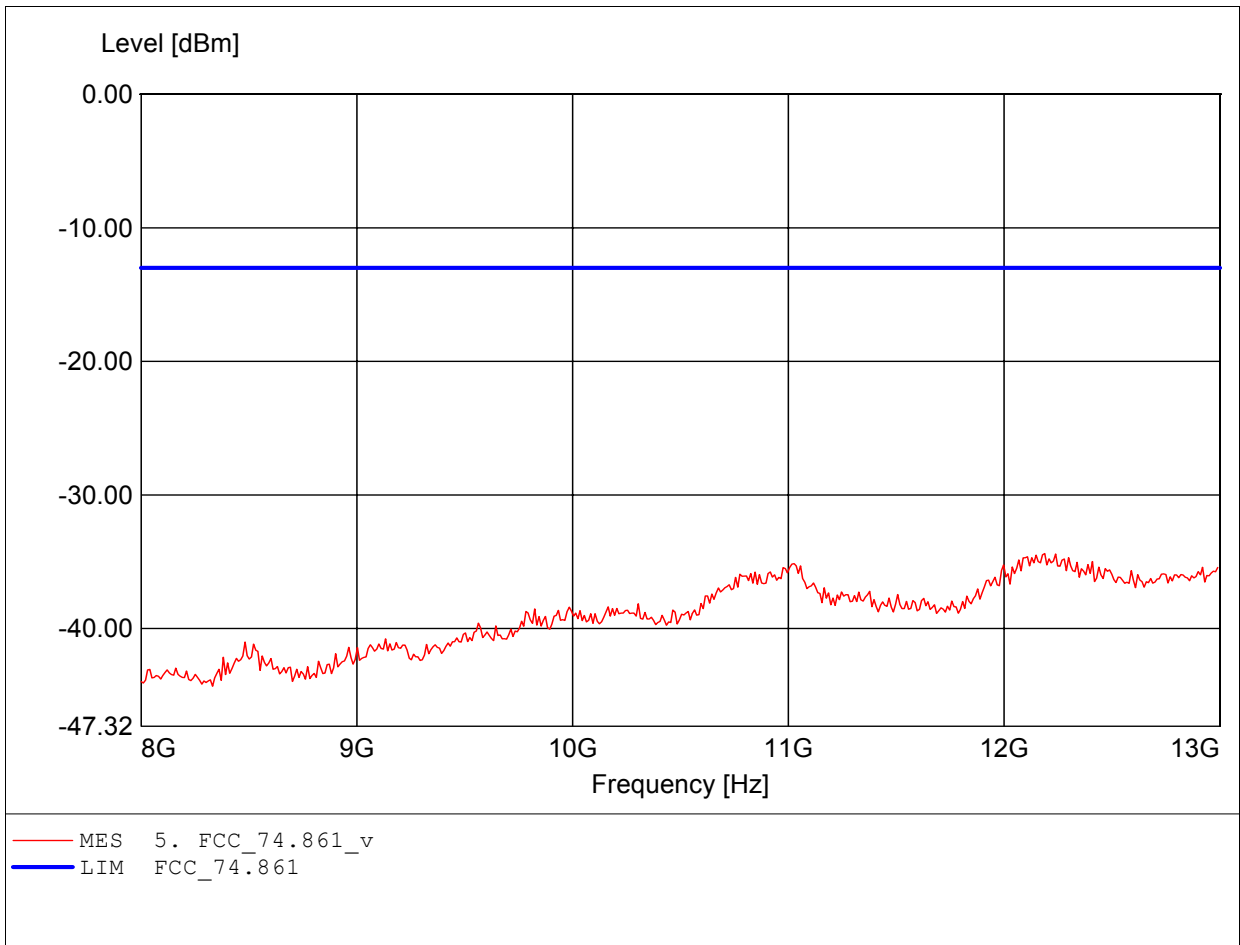

Spurious emissions under normal conditions

in according to FCC Part 74.861

EUT: Wireless Microphone
MODEL NO.: SM-6100 614.5MHz
Approval Holder: CHIAYO ELECTRONICS CO.,LTD.
Test Site / Operator: ETS / Mike Wu
Temperature/Voltage: Temp.: 23°C/ Unom.: 3 VDC (1.5V Battery x 2)
Test Specification: 74.861
Comment 1: Dist.: 3m, Ant.: HL 025, ampl.: 8-18GHz
Freq:12.208GHz Pmax:-34.93dBm RBW: 1 MHz

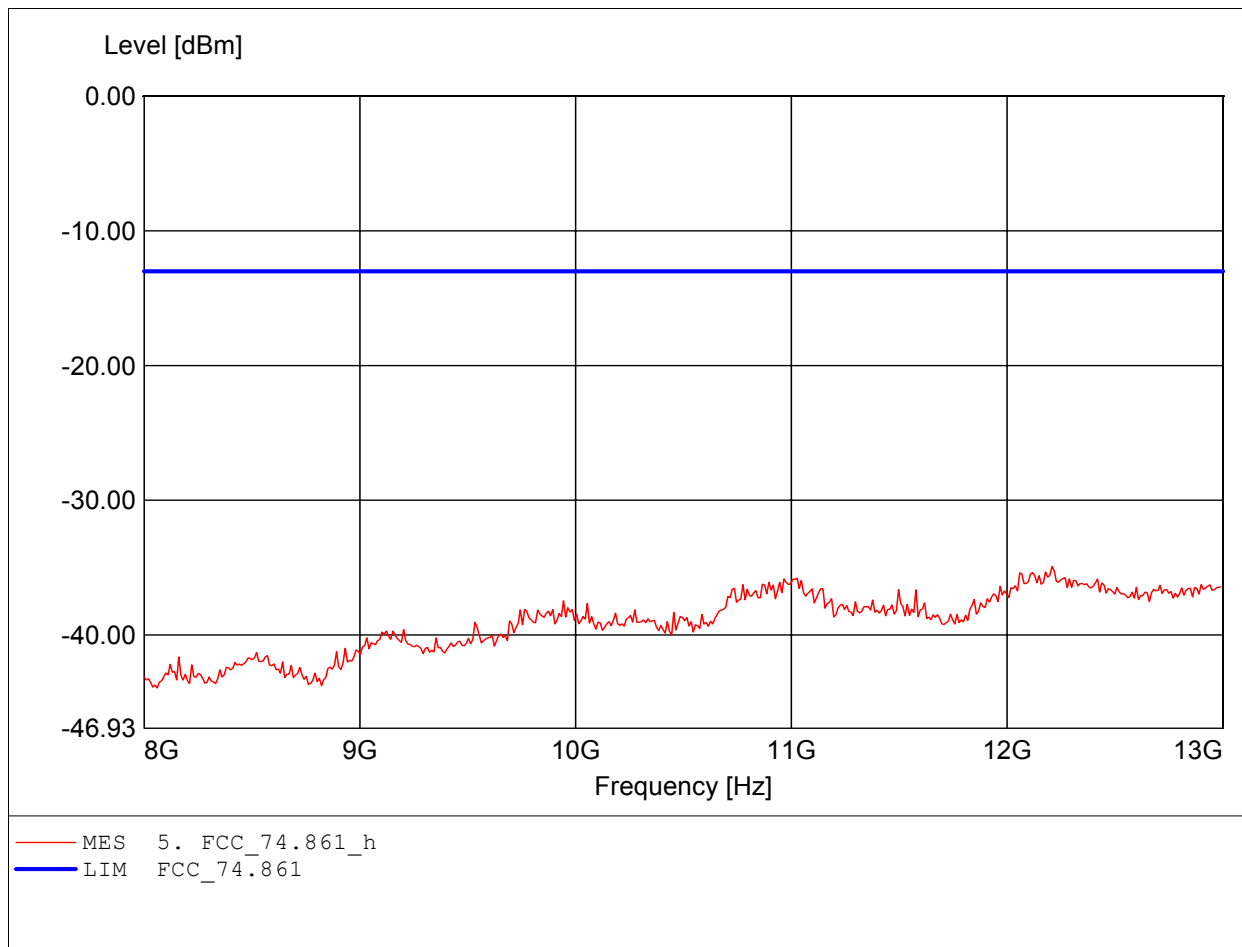

Spurious emissions under normal conditions

in according to FCC Part 74.861

EUT: Wireless Microphone
MODEL NO.: SM-6100 710MHz
Approval Holder: CHIAYO ELECTRONICS CO.,LTD.
Test Site / Operator: ETS / Mike Wu
Temperature/Voltage: Temp.: 23°C/ Unom.: 3 VDC (1.5V Battery x 2)
Test Specification: 74.861
Comment 1: Dist.: 3m, Ant.: HK 116
Freq:196.493MHz Pmax:-56.00dBm RBW: 100 kHz

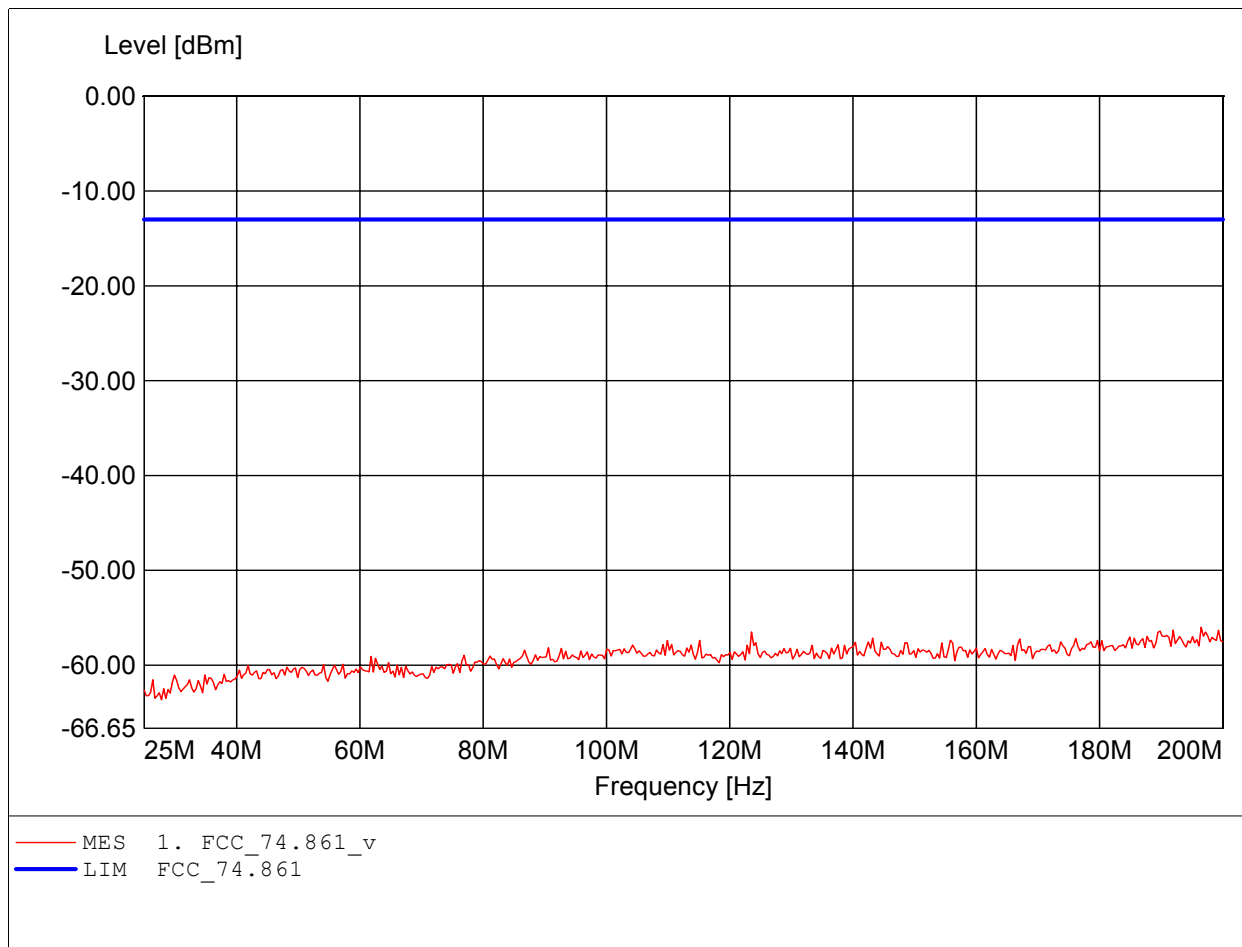

Spurious emissions under normal conditions

in according to FCC Part 74.861

EUT: Wireless Microphone
MODEL NO.: SM-6100 710MHz
Approval Holder: CHIAYO ELECTRONICS CO.,LTD.
Test Site / Operator: ETS / Mike Wu
Temperature/Voltage: Temp.: 23°C/ Unom.: 3 VDC (1.5V Battery x 2)
Test Specification: 74.861
Comment 1: Dist.: 3m, Ant.: HK 116
Freq:52.004MHz Pmax:-57.10dBm RBW: 100 kHz

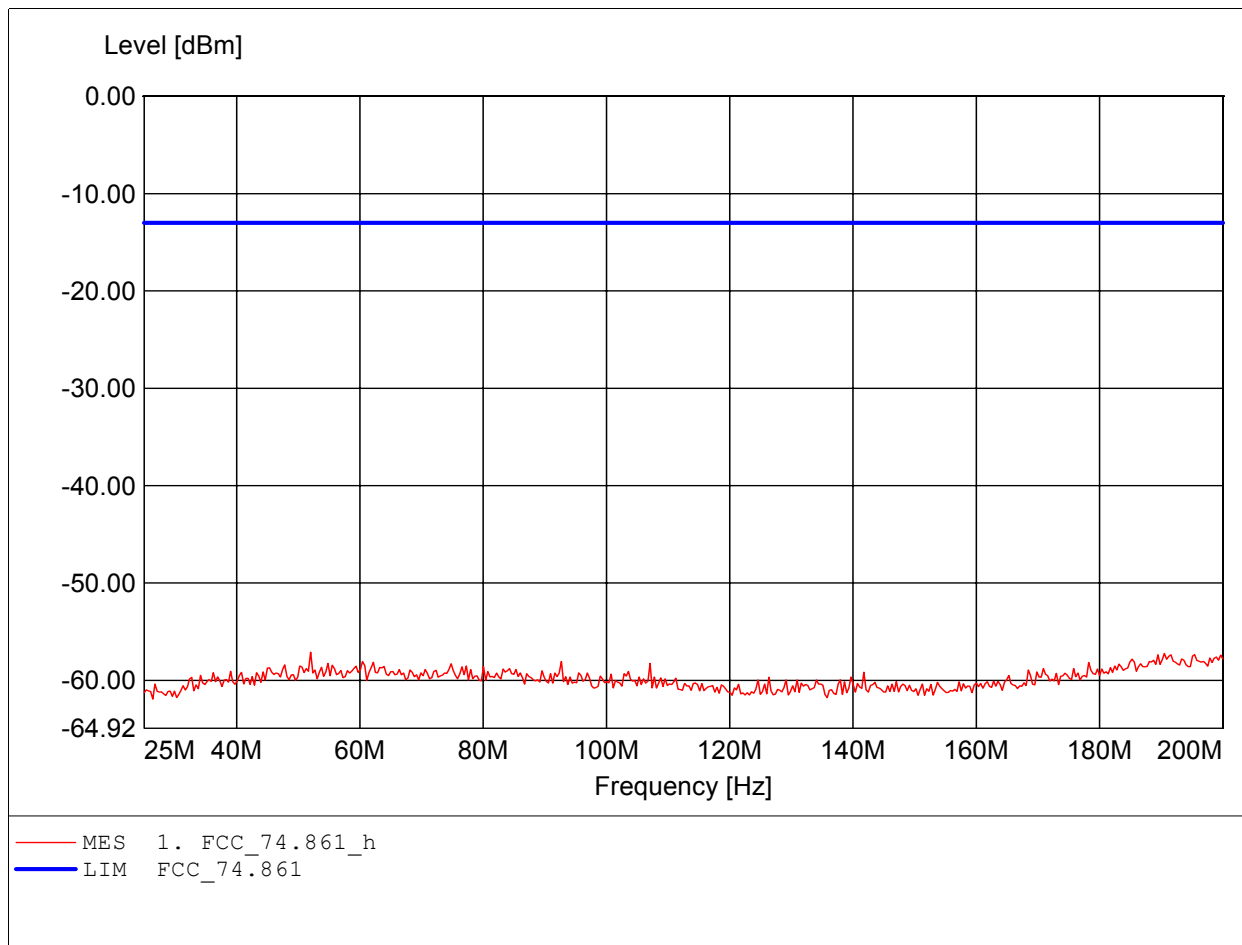

Spurious emissions under normal conditions

in according to FCC Part 74.861

EUT: Wireless Microphone
MODEL NO.: SM-6100 710MHz
Approval Holder: CHIAYO ELECTRONICS CO.,LTD.
Test Site / Operator: ETS / Mike Wu
Temperature/Voltage: Temp.: 23°C/ Unom.: 3 VDC (1.5V Battery x 2)
Test Specification: 74.861
Comment 1: Dist.: 3m, Ant.: HL 223, ampl.: 0.1-1GHz
Freq:953.507MHz Pmax:-68.50dBm RBW: 100 kHz

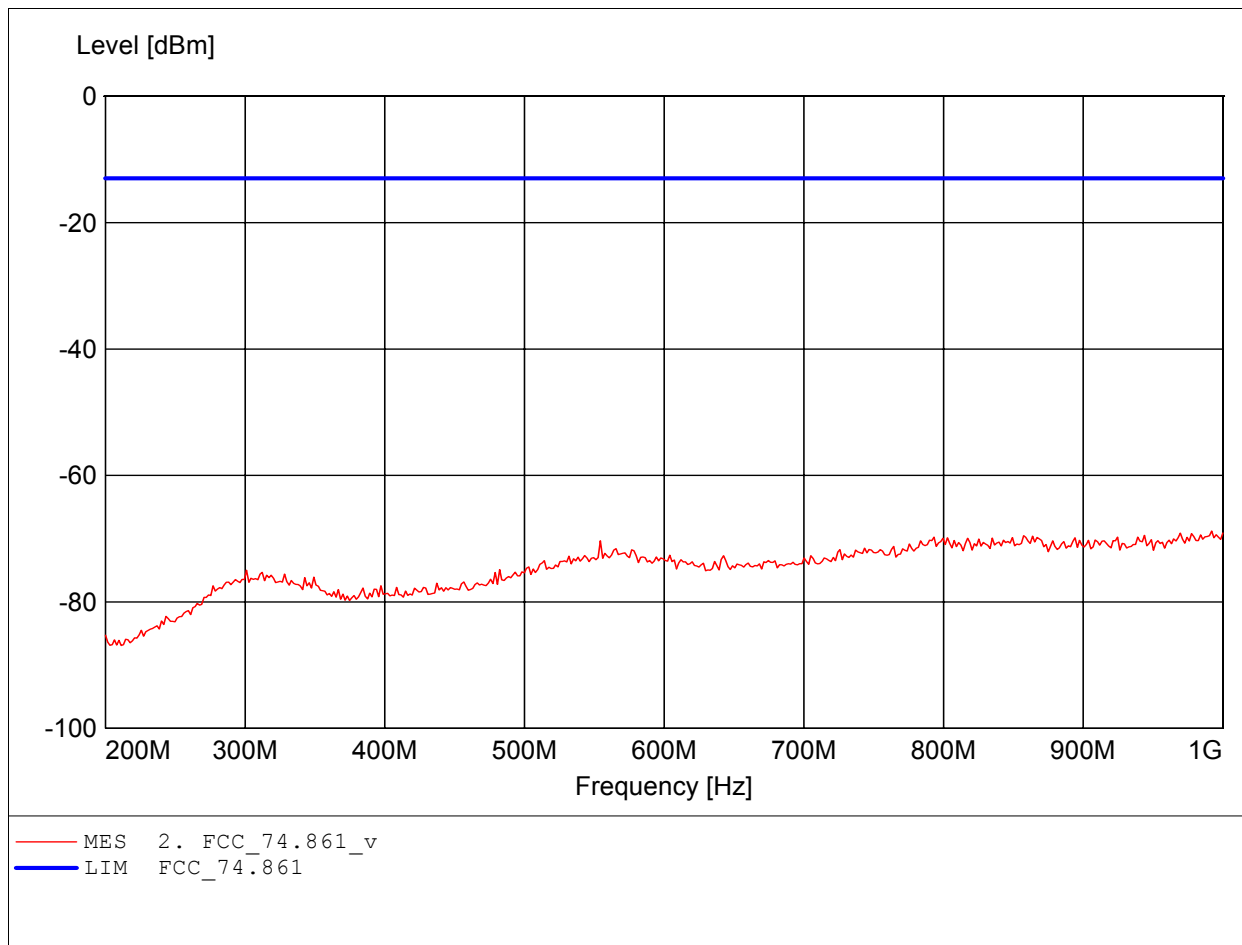

Spurious emissions under normal conditions

in according to FCC Part 74.861

EUT: Wireless Microphone
MODEL NO.: SM-6100 710MHz
Approval Holder: CHIAYO ELECTRONICS CO.,LTD.
Test Site / Operator: ETS / Mike Wu
Temperature/Voltage: Temp.: 23°C/ Unom.: 3 VDC (1.5V Battery x 2)
Test Specification: 74.861
Comment 1: Dist.: 3m, Ant.: HL 223, ampl.: 0.1-1GHz
Freq:955.110MHz Pmax:-66.10dBm RBW: 100 kHz

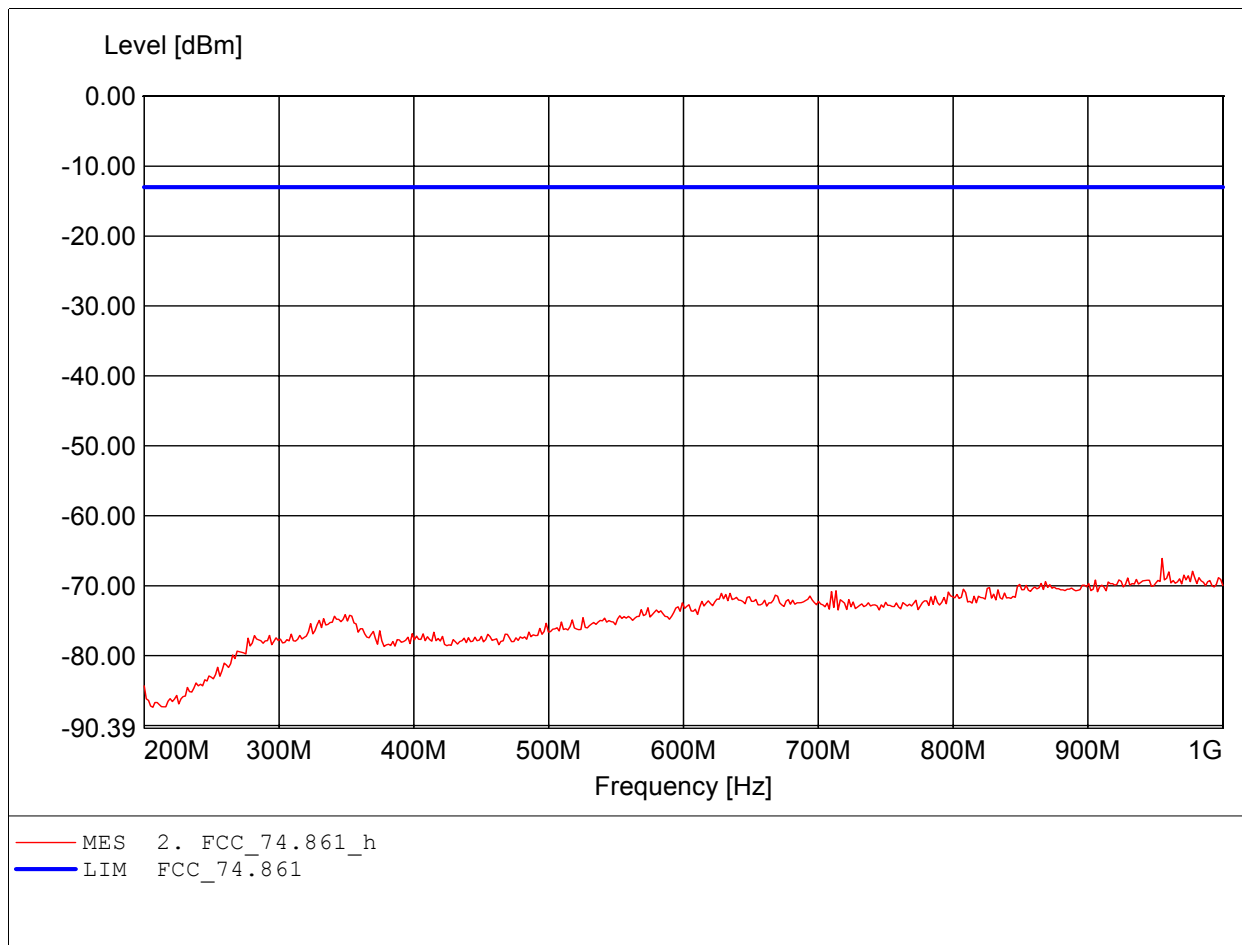

Spurious emissions under normal conditions

in according to FCC Part 74.861

EUT: Wireless Microphone
MODEL NO.: SM-6100 710MHz
Approval Holder: CHIAYO ELECTRONICS CO.,LTD.
Test Site / Operator: ETS / Mike Wu
Temperature/Voltage: Temp.: 23°C/ Unom.: 3 VDC (1.5V Battery x 2)
Test Specification: 74.861
Comment 1: Dist.: 3m, Ant.: HL 025, ampl.: 1-4GHz
Freq:3.531GHz Pmax:-50.45dBm RBW: 1 MHz

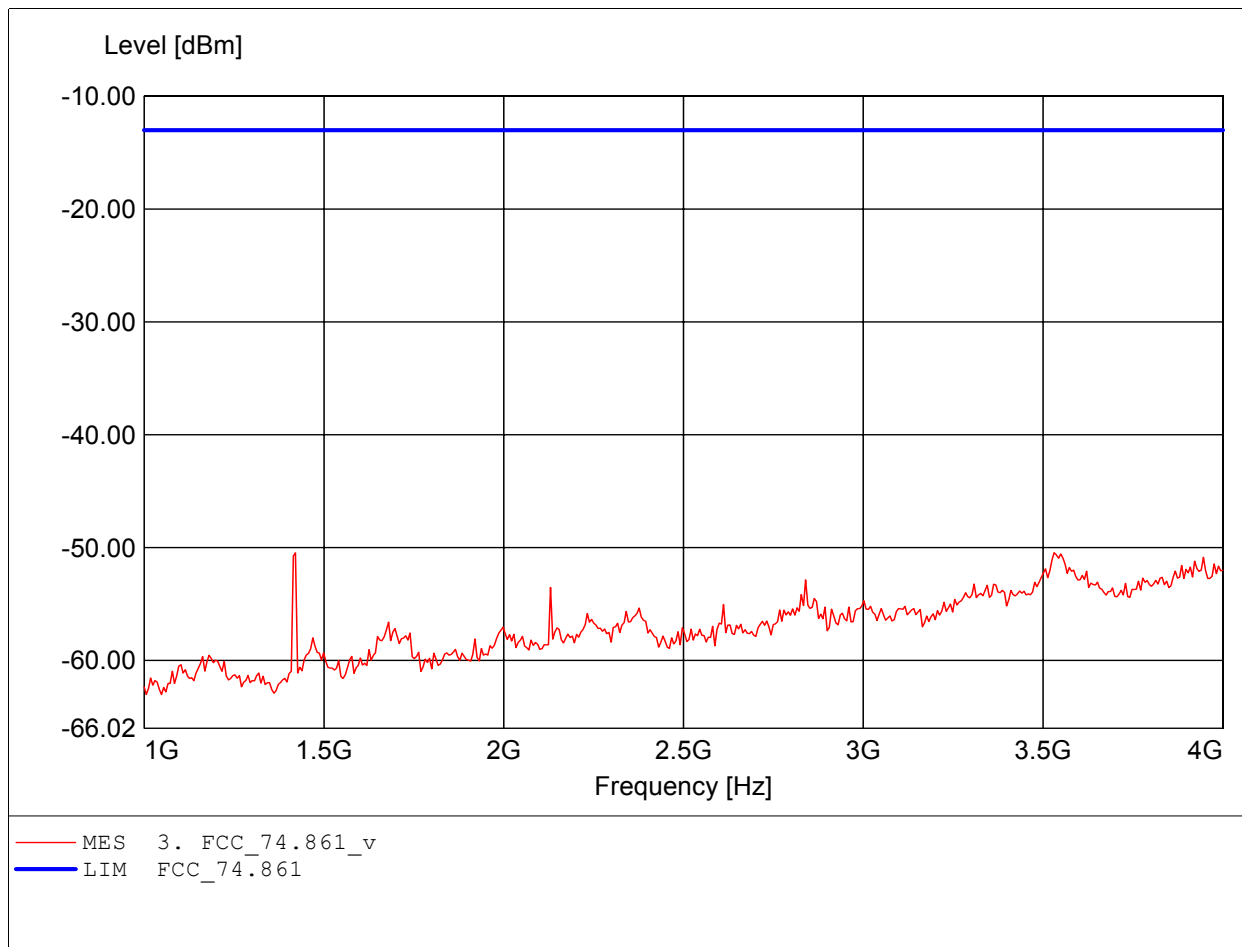

Spurious emissions under normal conditions

in according to FCC Part 74.861

EUT: Wireless Microphone
MODEL NO.: SM-6100 710MHz
Approval Holder: CHIAYO ELECTRONICS CO.,LTD.
Test Site / Operator: ETS / Mike Wu
Temperature/Voltage: Temp.: 23°C/ Unom.: 3 VDC (1.5V Battery x 2)
Test Specification: 74.861
Comment 1: Dist.: 3m, Ant.: HL 025, ampl.: 1-4GHz
Freq:1.415GHz Pmax:-45.08dBm RBW: 1 MHz

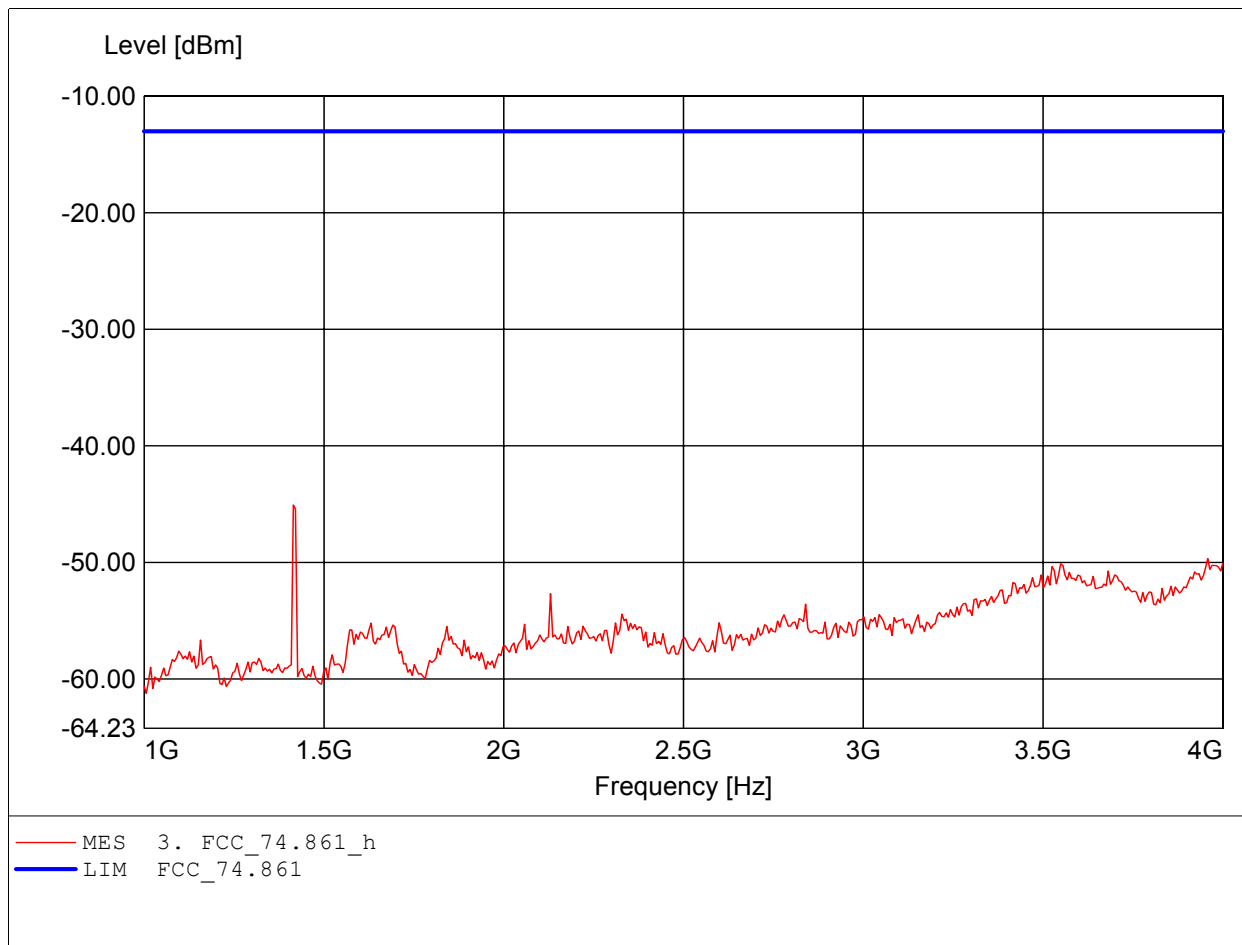

Spurious emissions under normal conditions

in according to FCC Part 74.861

EUT: Wireless Microphone
MODEL NO.: SM-6100 710MHz
Approval Holder: CHIAYO ELECTRONICS CO.,LTD.
Test Site / Operator: ETS / Mike Wu
Temperature/Voltage: Temp.: 23°C/ Unom.: 3 VDC (1.5V Battery x 2)
Test Specification: 74.861
Comment 1: Dist.: 3m, Ant.: HL 025, ampl.: 4-8GHz
Freq:7.599GHz Pmax:-42.92dBm RBW: 1 MHz

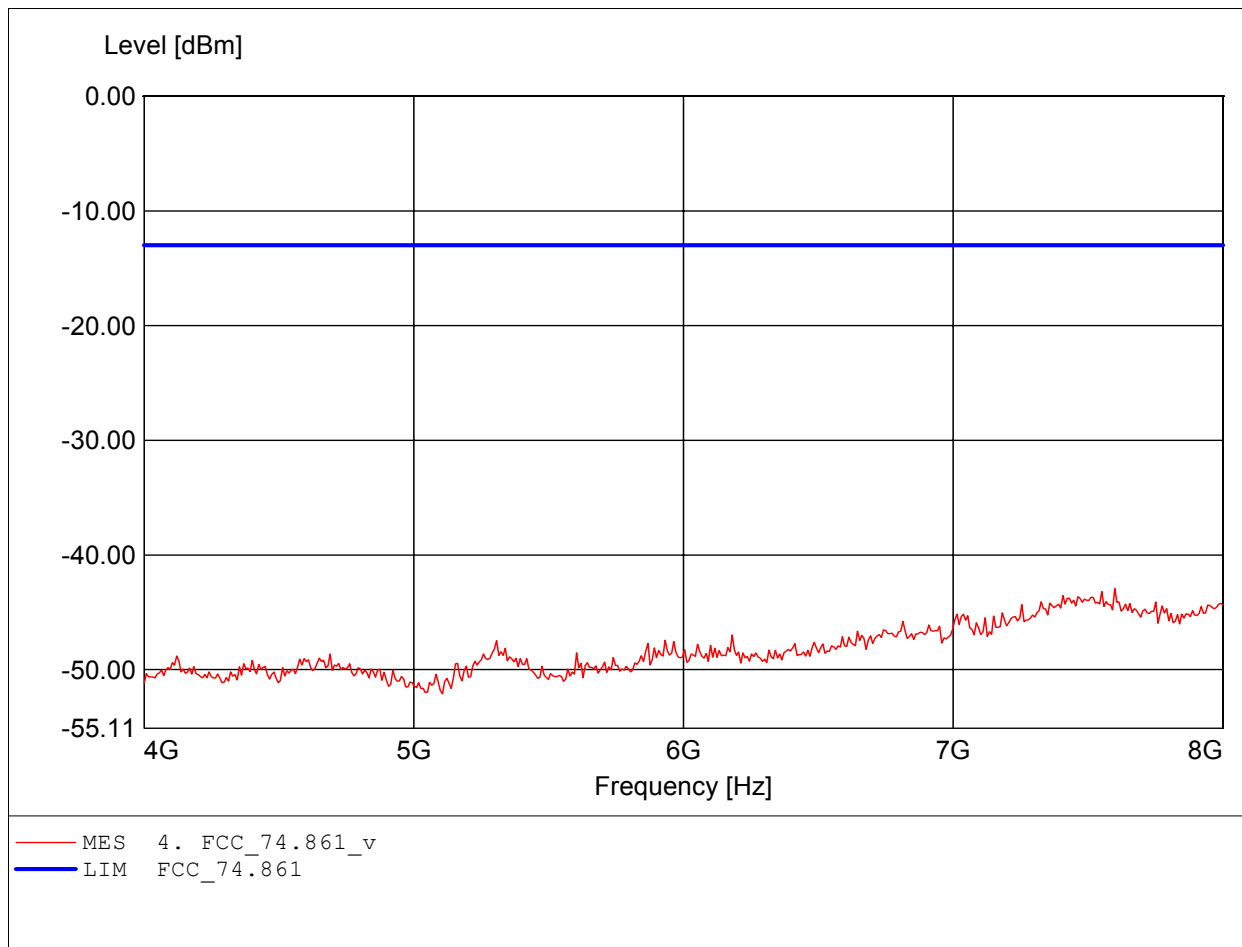

Spurious emissions under normal conditions

in according to FCC Part 74.861

EUT: Wireless Microphone
MODEL NO.: SM-6100 710MHz
Approval Holder: CHIAYO ELECTRONICS CO.,LTD.
Test Site / Operator: ETS / Mike Wu
Temperature/Voltage: Temp.: 23°C/ Unom.: 3 VDC (1.5V Battery x 2)
Test Specification: 74.861
Comment 1: Dist.: 3m, Ant.: HL 025, ampl.: 4-8GHz
Freq:7.519GHz Pmax:-42.47dBm RBW: 1 MHz

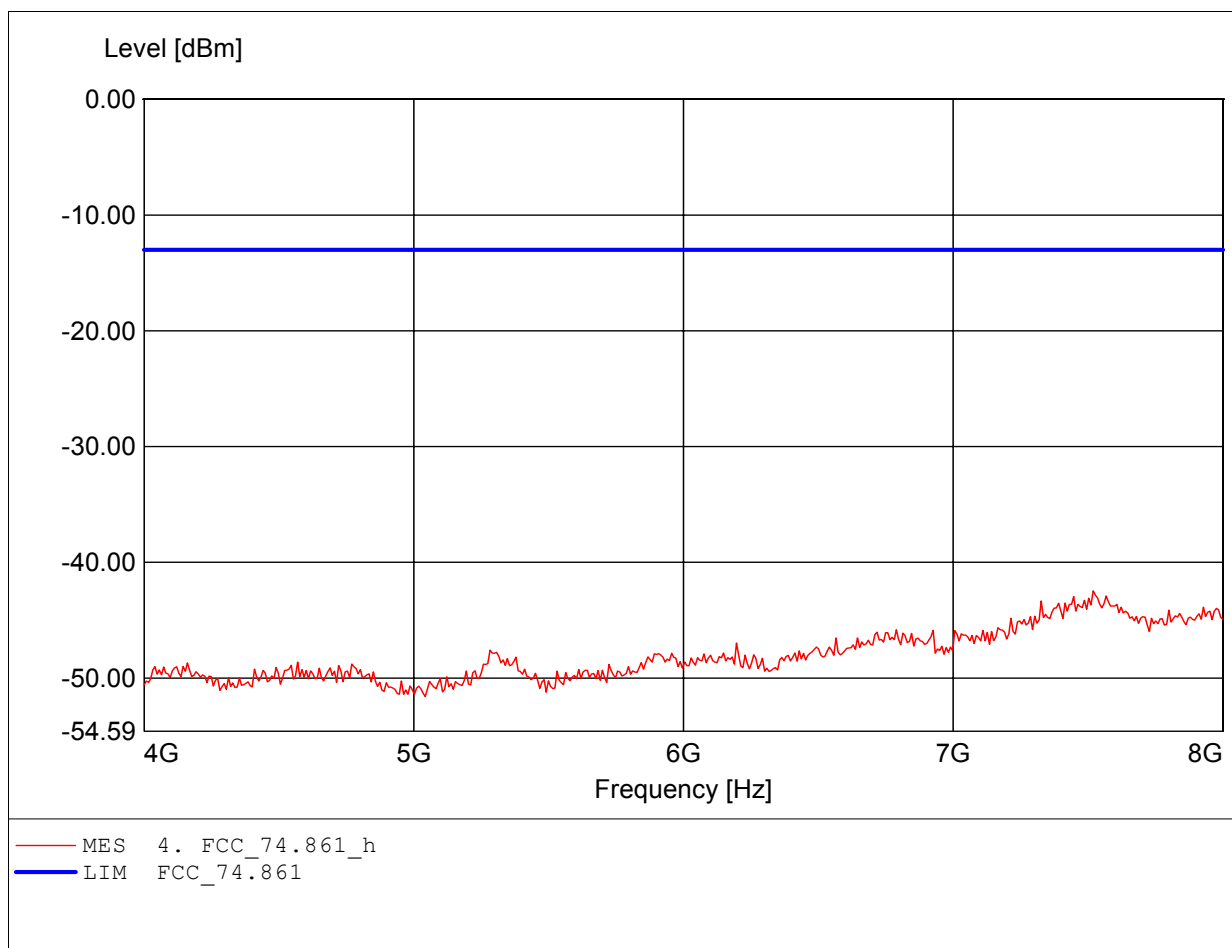

Spurious emissions under normal conditions

in according to FCC Part 74.861

EUT: Wireless Microphone
MODEL NO.: SM-6100 710MHz
Approval Holder: CHIAYO ELECTRONICS CO.,LTD.
Test Site / Operator: ETS / Mike Wu
Temperature/Voltage: Temp.: 23°C/ Unom.: 3 VDC (1.5V Battery x 2)
Test Specification: 74.861
Comment 1: Dist.: 3m, Ant.: HL 025, ampl.: 8-18GHz
Freq:12.108GHz Pmax:-34.74dBm RBW: 1 MHz

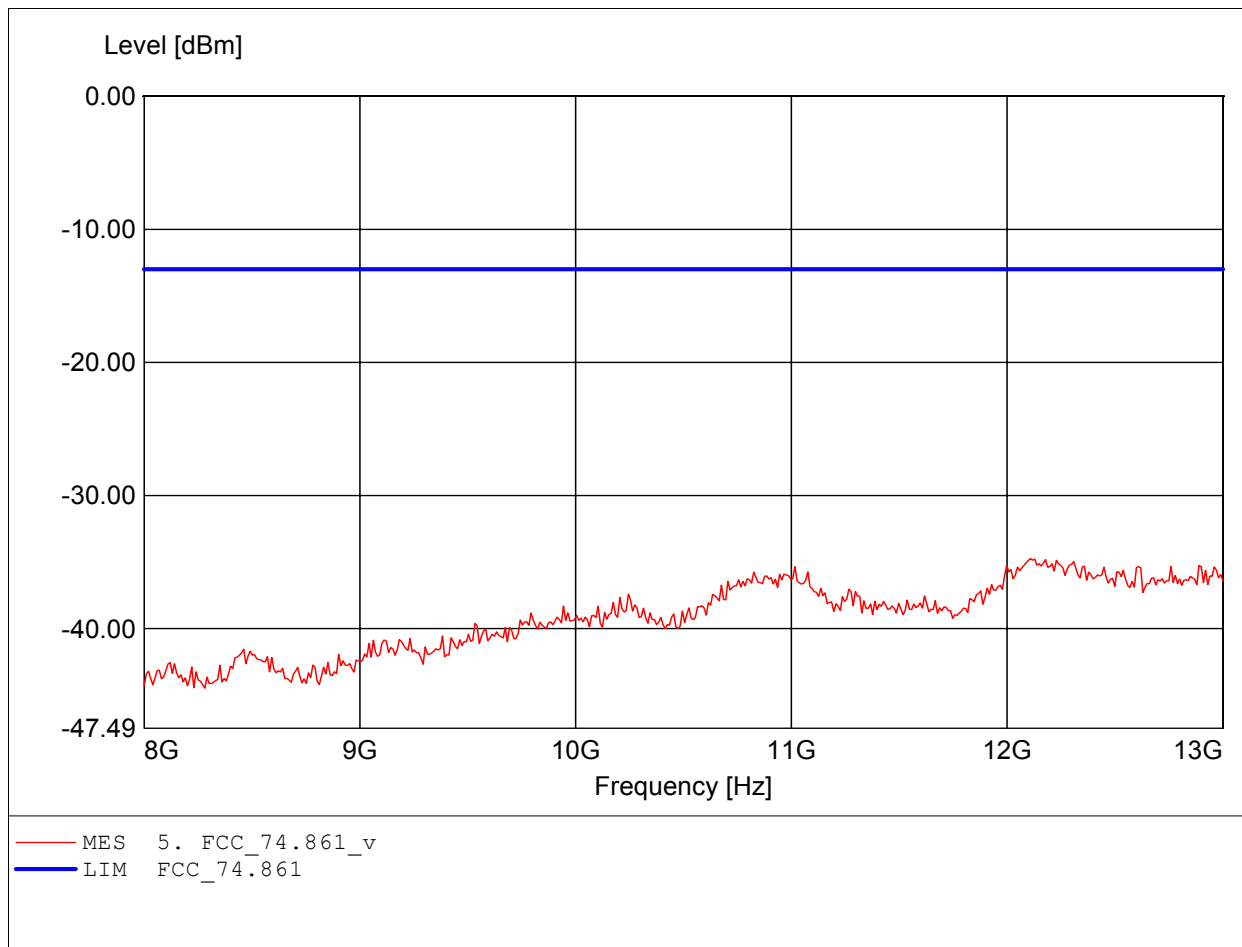

Spurious emissions under normal conditions

in according to FCC Part 74.861

EUT: Wireless Microphone
MODEL NO.: SM-6100 710MHz
Approval Holder: CHIAYO ELECTRONICS CO.,LTD.
Test Site / Operator: ETS / Mike Wu
Temperature/Voltage: Temp.: 23°C/ Unom.: 3 VDC (1.5V Battery x 2)
Test Specification: 74.861
Comment 1: Dist.: 3m, Ant.: HL 025, ampl.: 8-18GHz
Freq:12.188GHz Pmax:-35.09dBm RBW: 1 MHz

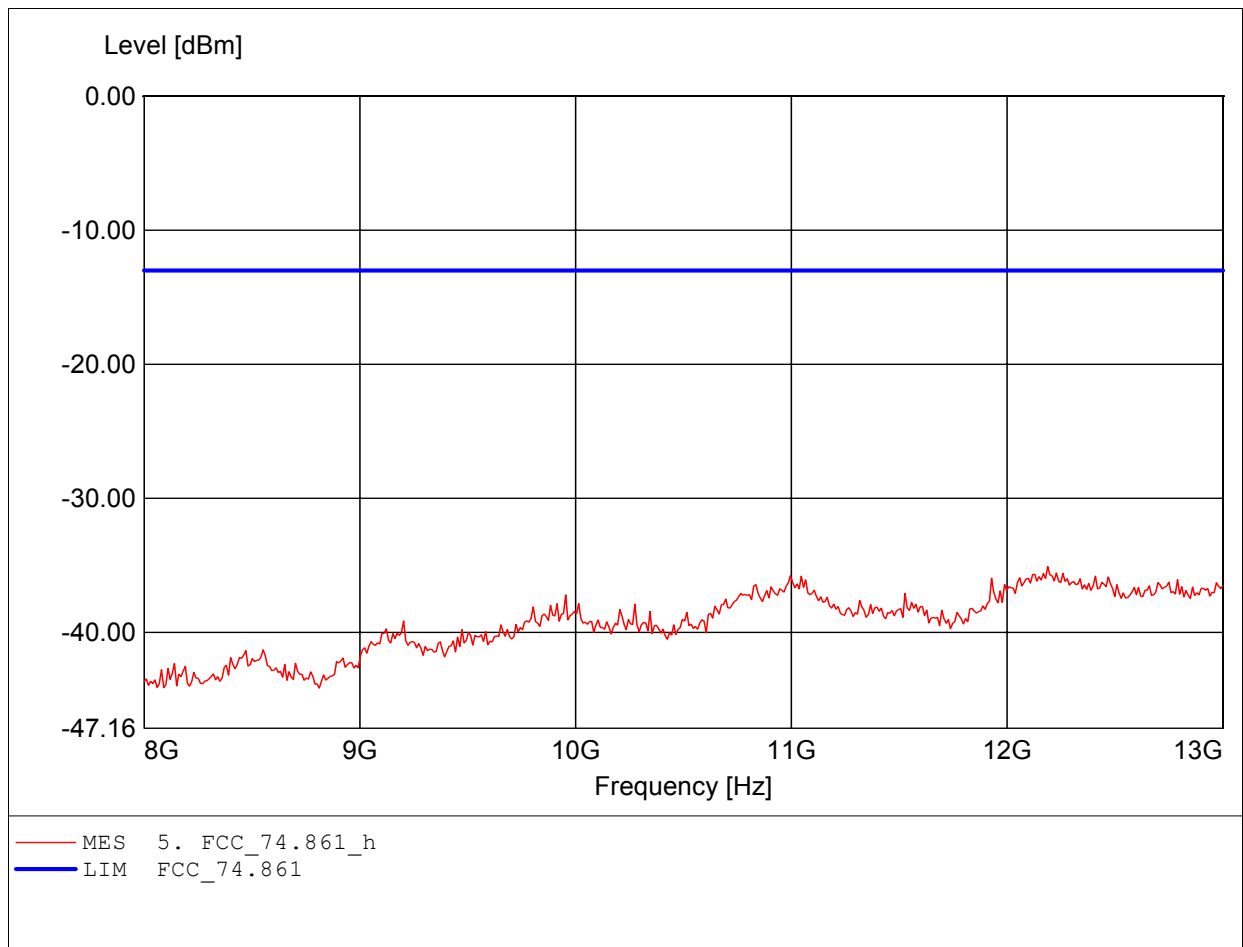

Spurious emissions under normal conditions

in according to FCC Part 74.861

EUT: Wireless Microphone
MODEL NO.: SM-6100 806MHz
Approval Holder: CHIAYO ELECTRONICS CO.,LTD.
Test Site / Operator: ETS / Mike Wu
Temperature/Voltage: Temp.: 23°C/ Unom.: 3 VDC (1.5V Battery x 2)
Test Specification: 74.861
Comment 1: Dist.: 3m, Ant.: HK 116
Freq:190.180MHz Pmax:-56.21dBm RBW: 100 kHz

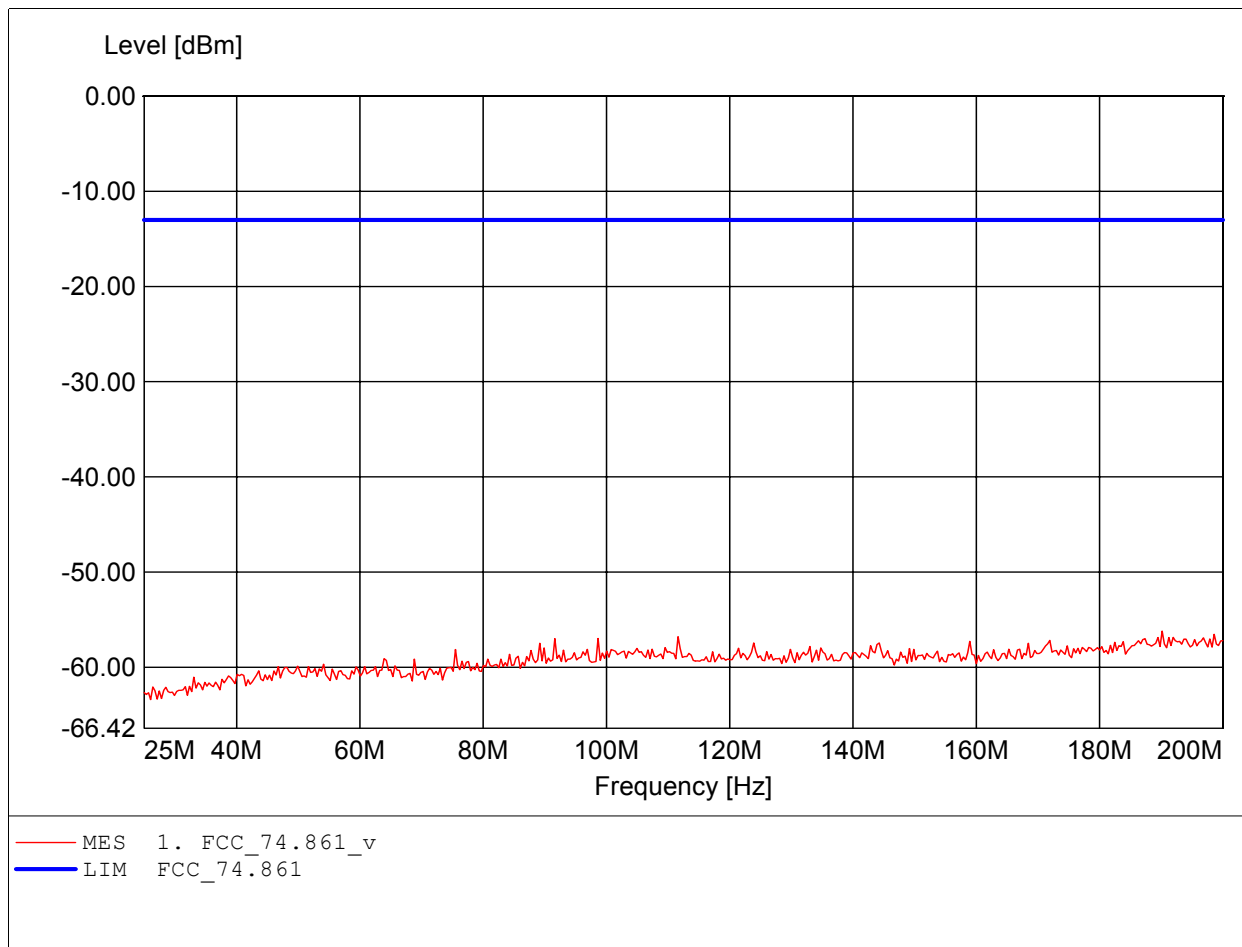

Spurious emissions under normal conditions

in according to FCC Part 74.861

EUT: Wireless Microphone
MODEL NO.: SM-6100 806MHz
Approval Holder: CHIAYO ELECTRONICS CO.,LTD.
Test Site / Operator: ETS / Mike Wu
Temperature/Voltage: Temp.: 23°C/ Unom.: 3 VDC (1.5V Battery x 2)
Test Specification: 74.861
Comment 1: Dist.: 3m, Ant.: HK 116
Freq:191.583MHz Pmax:-56.75dBm RBW: 100 kHz

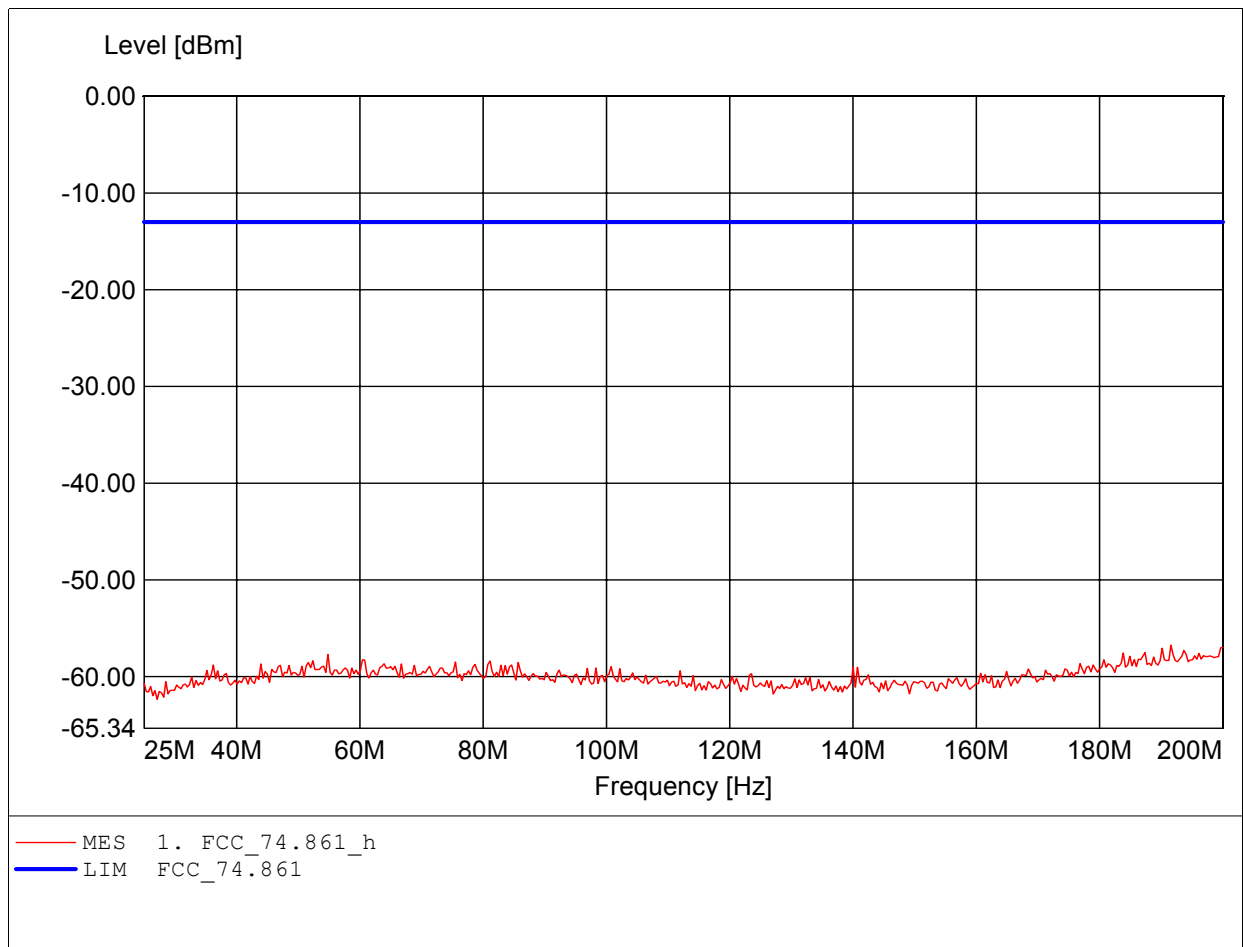

Spurious emissions under normal conditions

in according to FCC Part 74.861

EUT: Wireless Microphone
MODEL NO.: SM-6100 806MHz
Approval Holder: CHIAYO ELECTRONICS CO.,LTD.
Test Site / Operator: ETS / Mike Wu
Temperature/Voltage: Temp.: 23°C/ Unom.: 3 VDC (1.5V Battery x 2)
Test Specification: 74.861
Comment 1: Dist.: 3m, Ant.: HL 223, ampl.: 0.1-1GHz
Freq:953.507MHz Pmax:-68.50dBm RBW: 100 kHz

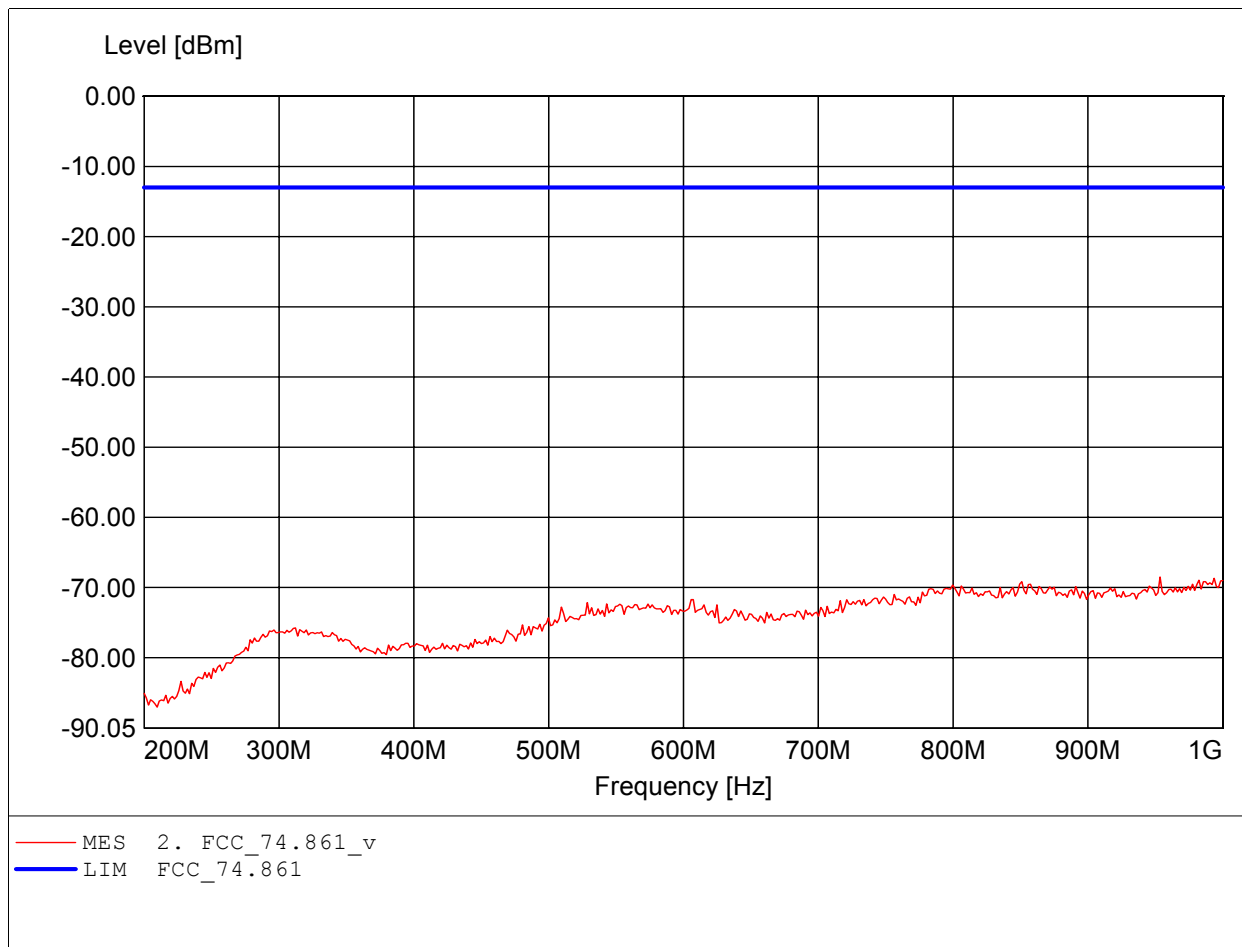

Spurious emissions under normal conditions

in according to FCC Part 74.861

EUT: Wireless Microphone
MODEL NO.: SM-6100 806MHz
Approval Holder: CHIAYO ELECTRONICS CO.,LTD.
Test Site / Operator: ETS / Mike Wu
Temperature/Voltage: Temp.: 23°C/ Unom.: 3 VDC (1.5V Battery x 2)
Test Specification: 74.861
Comment 1: Dist.: 3m, Ant.: HL 223, ampl.: 0.1-1GHz
Freq:979.158MHz Pmax:-68.43dBm RBW: 100 kHz

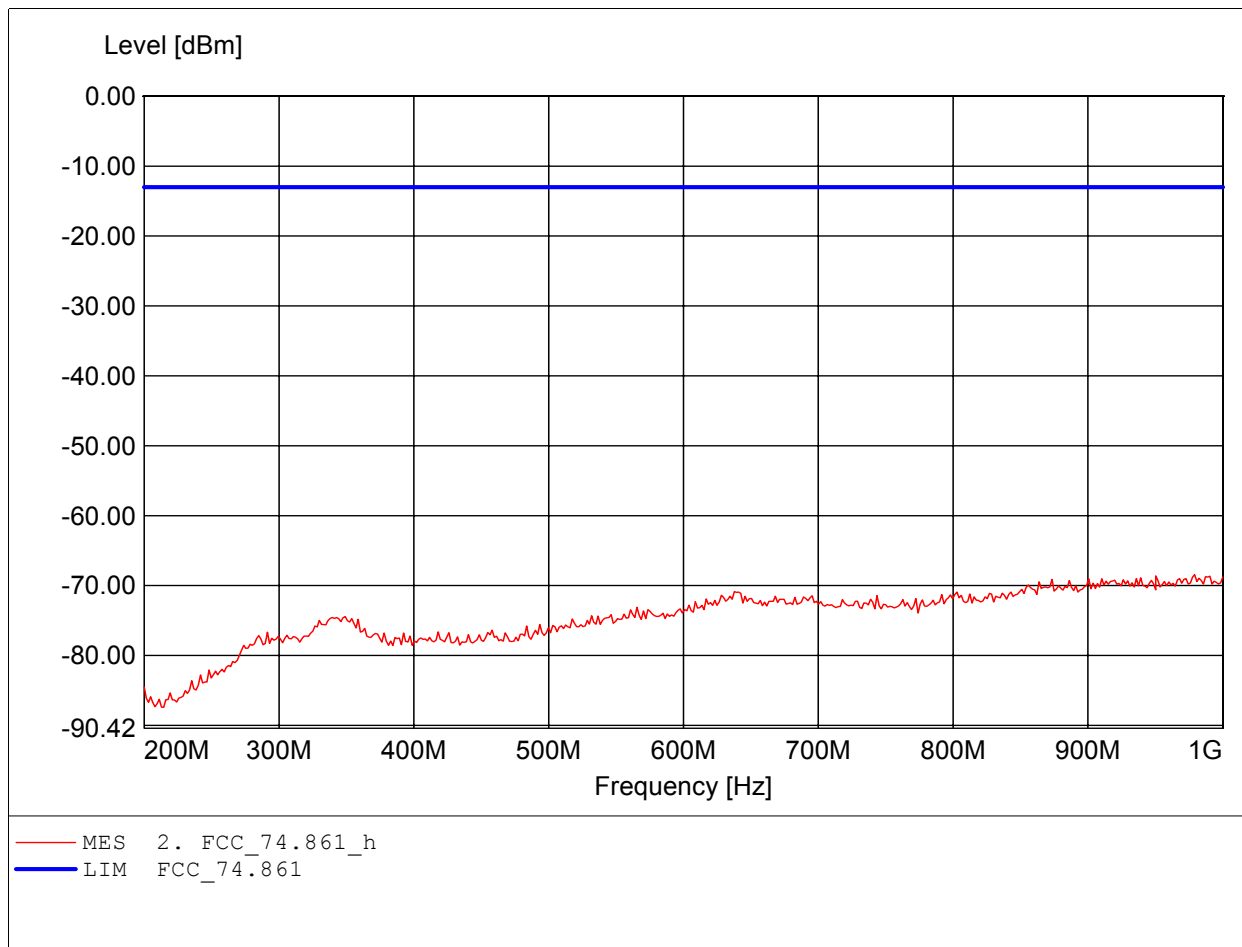

Spurious emissions under normal conditions

in according to FCC Part 74.861

EUT: Wireless Microphone
MODEL NO.: SM-6100 806MHz
Approval Holder: CHIAYO ELECTRONICS CO.,LTD.
Test Site / Operator: ETS / Mike Wu
Temperature/Voltage: Temp.: 23°C/ Unom.: 3 VDC (1.5V Battery x 2)
Test Specification: 74.861
Comment 1: Dist.: 3m, Ant.: HL 025, ampl.: 1-4GHz
Freq:1.607GHz Pmax:-47.11dBm RBW: 1 MHz

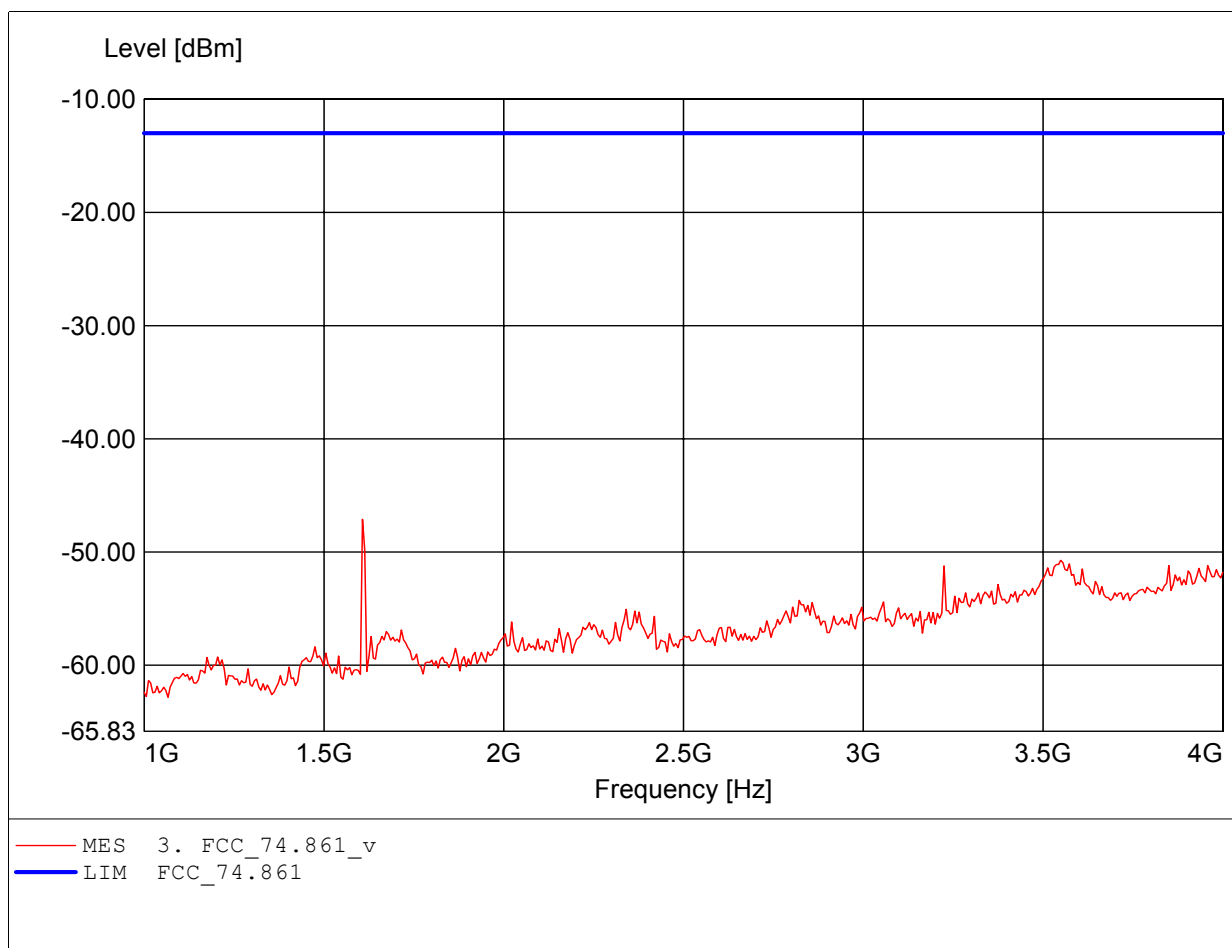

Spurious emissions under normal conditions

in according to FCC Part 74.861

EUT: Wireless Microphone
MODEL NO.: SM-6100 806MHz
Approval Holder: CHIAYO ELECTRONICS CO.,LTD.
Test Site / Operator: ETS / Mike Wu
Temperature/Voltage: Temp.: 23°C/ Unom.: 3 VDC (1.5V Battery x 2)
Test Specification: 74.861
Comment 1: Dist.: 3m, Ant.: HL 025, ampl.: 1-4GHz
Freq:1.607GHz Pmax:-44.19dBm RBW: 1 MHz

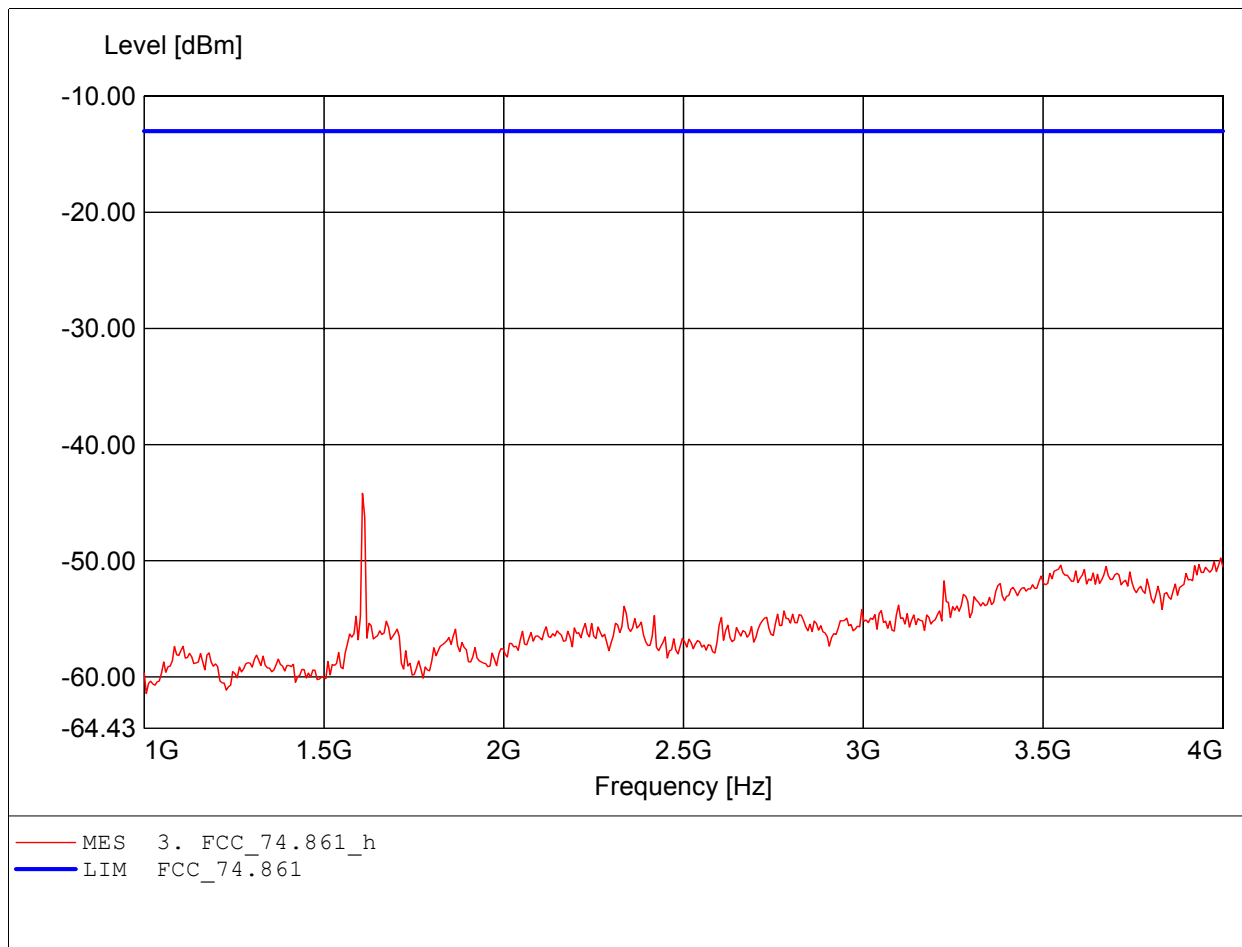

Spurious emissions under normal conditions

in according to FCC Part 74.861

EUT: Wireless Microphone
MODEL NO.: SM-6100 806MHz
Approval Holder: CHIAYO ELECTRONICS CO.,LTD.
Test Site / Operator: ETS / Mike Wu
Temperature/Voltage: Temp.: 23°C/ Unom.: 3 VDC (1.5V Battery x 2)
Test Specification: 74.861
Comment 1: Dist.: 3m, Ant.: HL 025, ampl.: 4-8GHz
Freq:7.535GHz Pmax:-42.96dBm RBW: 1 MHz

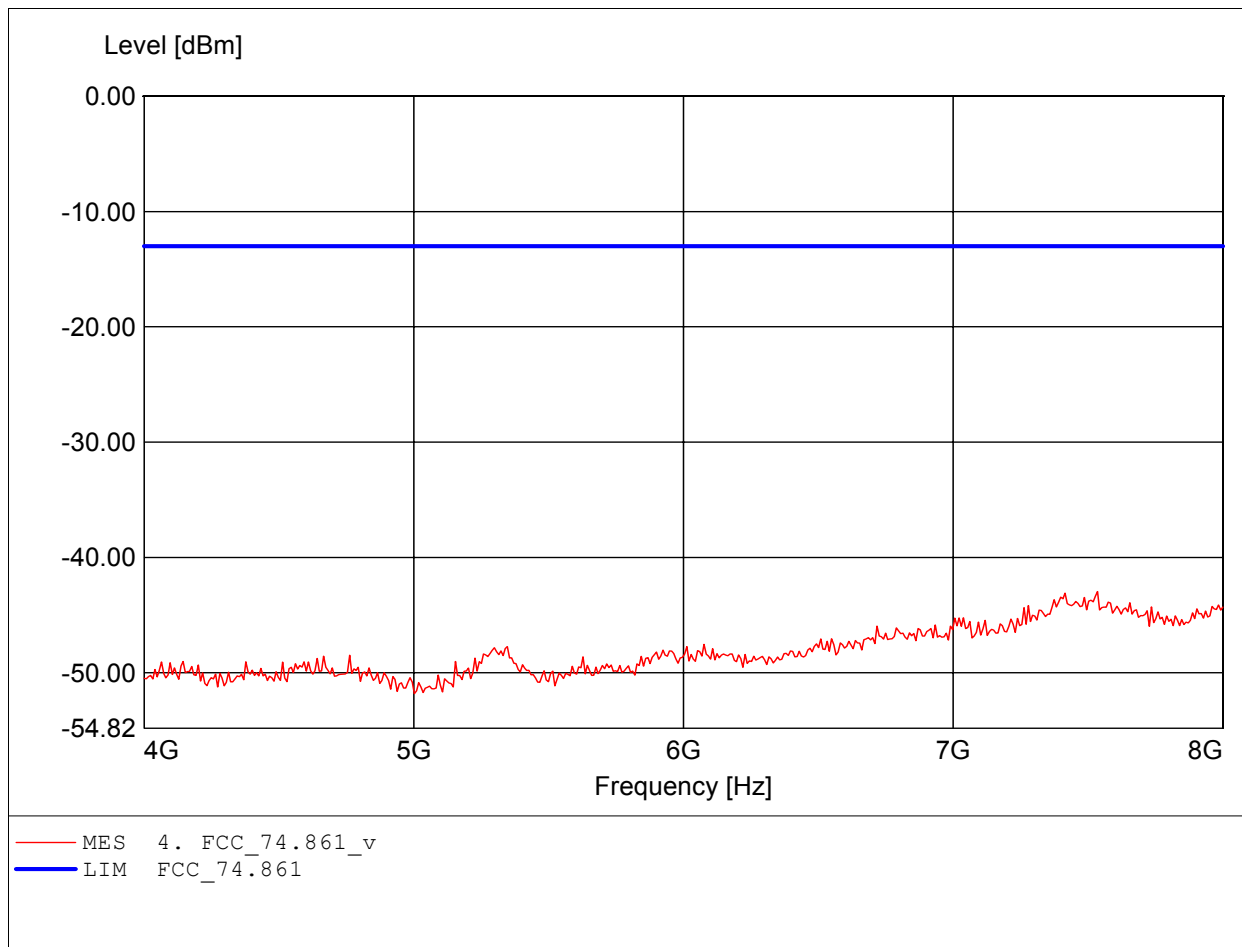

Spurious emissions under normal conditions

in according to FCC Part 74.861

EUT: Wireless Microphone
MODEL NO.: SM-6100 806MHz
Approval Holder: CHIAYO ELECTRONICS CO.,LTD.
Test Site / Operator: ETS / Mike Wu
Temperature/Voltage: Temp.: 23°C/ Unom.: 3 VDC (1.5V Battery x 2)
Test Specification: 74.861
Comment 1: Dist.: 3m, Ant.: HL 025, ampl.: 4-8GHz
Freq:7.455GHz Pmax:-42.31dBm RBW: 1 MHz

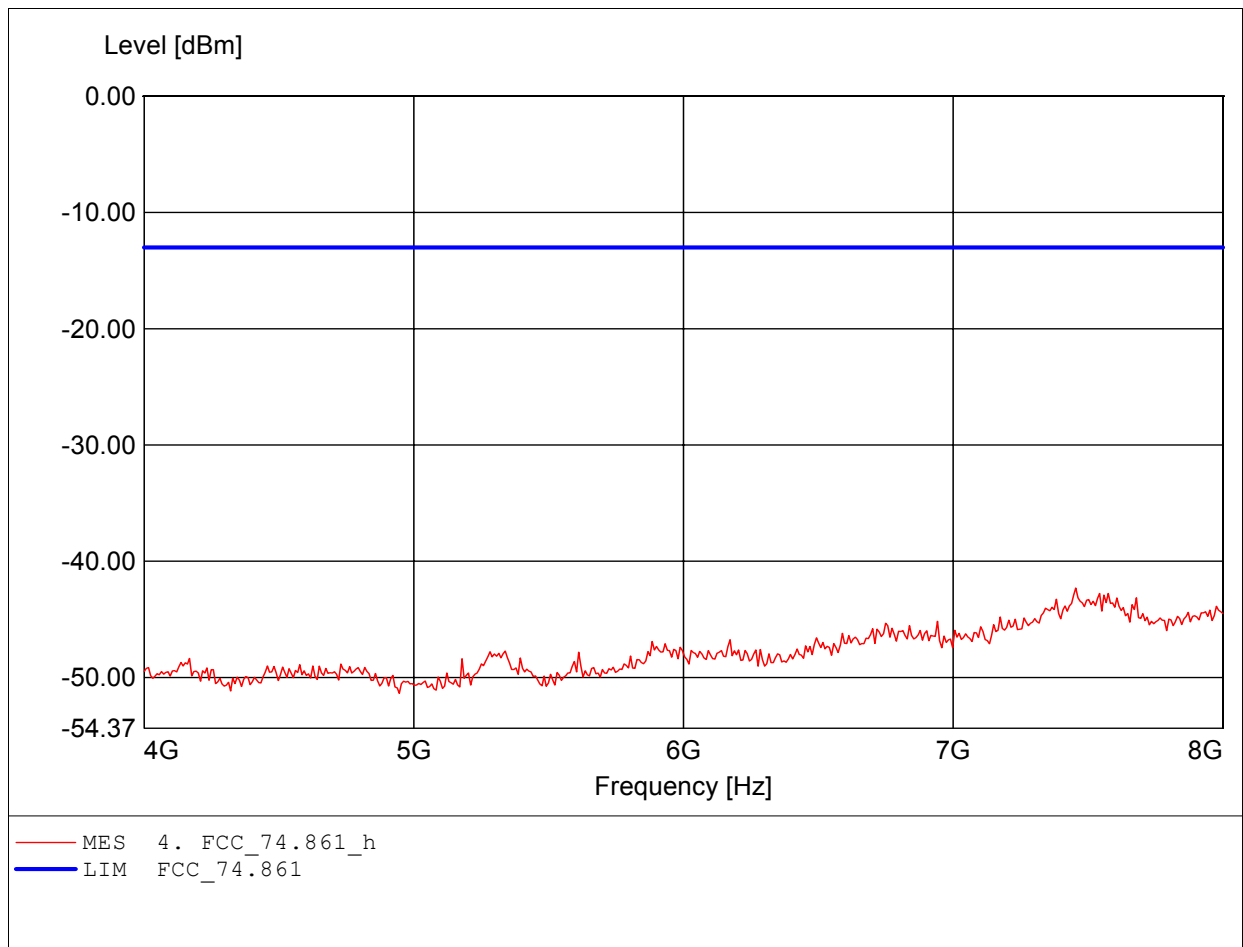

Spurious emissions under normal conditions

in according to FCC Part 74.861

EUT: Wireless Microphone
MODEL NO.: SM-6100 806MHz
Approval Holder: CHIAYO ELECTRONICS CO.,LTD.
Test Site / Operator: ETS / Mike Wu
Temperature/Voltage: Temp.: 23°C/ Unom.: 3 VDC (1.5V Battery x 2)
Test Specification: 74.861
Comment 1: Dist.: 3m, Ant.: HL 025, ampl.: 8-18GHz
Freq:12.178GHz Pmax:-33.71dBm RBW: 1 MHz

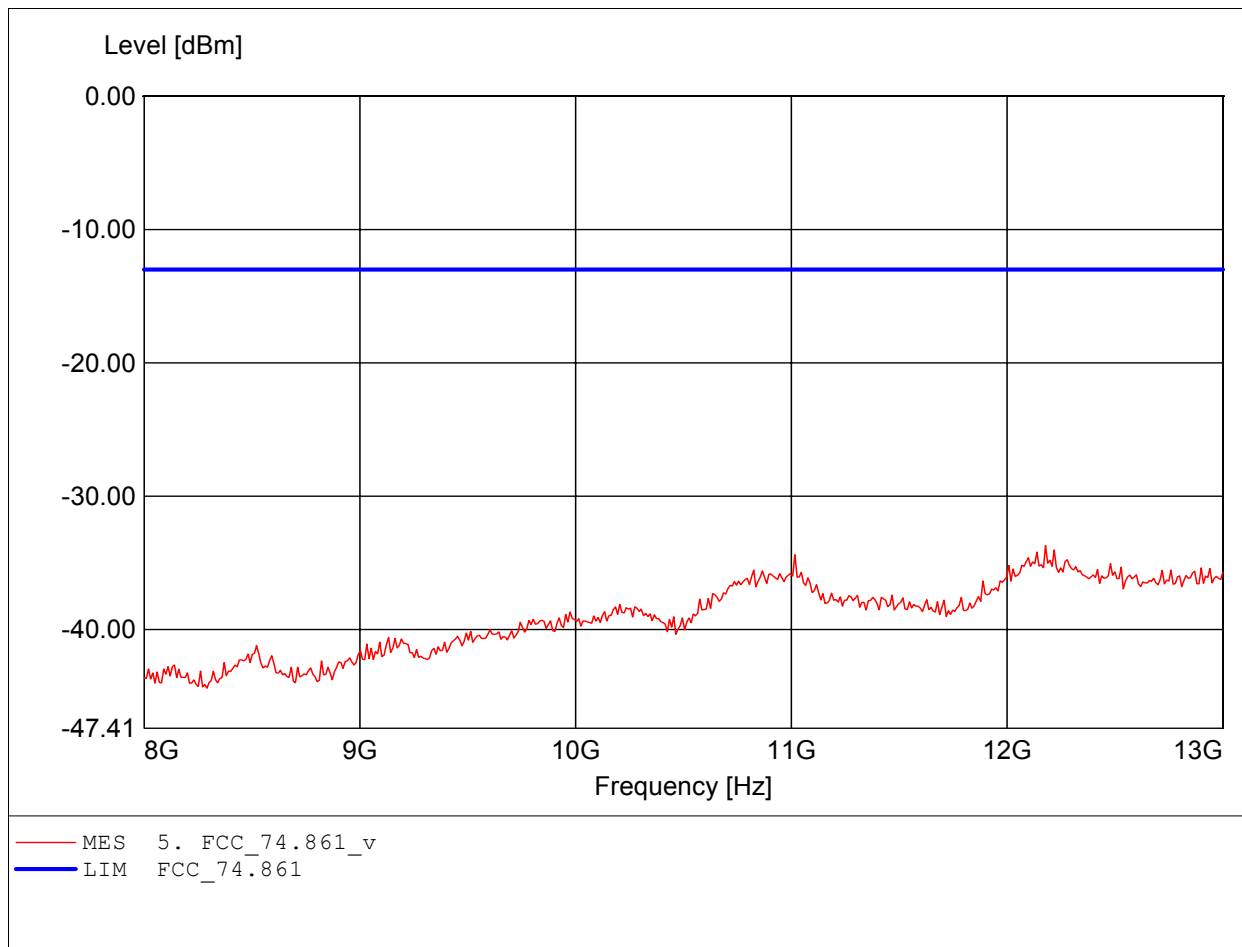

Spurious emissions under normal conditions

in according to FCC Part 74.861

EUT: Wireless Microphone
MODEL NO.: SM-6100 806MHz
Approval Holder: CHIAYO ELECTRONICS CO.,LTD.
Test Site / Operator: ETS / Mike Wu
Temperature/Voltage: Temp.: 23°C/ Unom.: 3 VDC (1.5V Battery x 2)
Test Specification: 74.861
Comment 1: Dist.: 3m, Ant.: HL 025, ampl.: 8-18GHz
Freq:12.178GHz Pmax:-34.84dBm RBW: 1 MHz

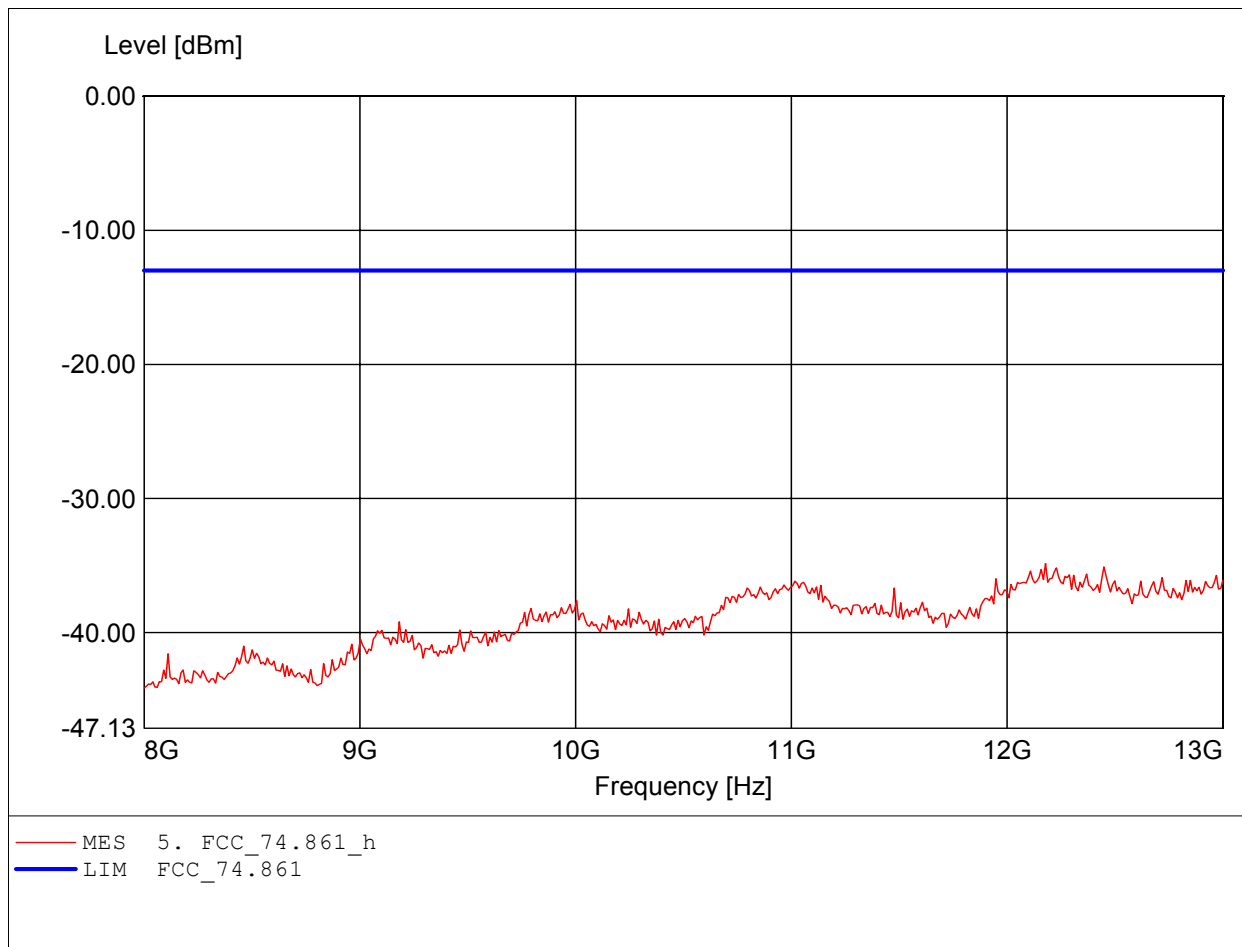

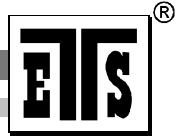

Registration number: W6M20508-6114-C-1
FCC ID: CINSM-6100

Appendix F

Line Conducted Emissions

This is not required the sample is battery used.



Registration number: W6M20508-6114-C-1
FCC ID: CINSM-6100

Appendix G

Frequency Stability vs. Temperature

No diagrams
Refer to point 12.2

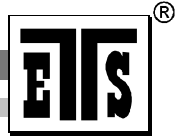

Registration number: W6M20508-6114-C-1
FCC ID: CINSM-6100

Appendix H

Frequency Stability vs. Voltage

No diagrams
Refer to point 13.2



Registration number: W6M20508-6114-C-1
FCC ID: CINSM-6100

Appendix I

Pictures