

RS2-G3

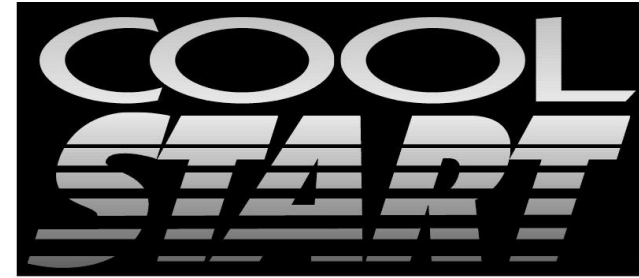

ONE BUTTON 2-WAY REMOTE START SYSTEM

INSTALLATION INSTRUCTIONS

CONGRATULATIONS on your choice of a “Cool Start” System with Data Port Technology for direct connection to bypass module by **Crime stopper** Security Products Inc. This booklet contains the information necessary for installing your remote starter system. If any questions arise, contact your installation dealer or **Crime stopper** Security Products Inc. at the Tech Support number below.

DISCLAIMER:

*This installation book is designed for the installer or individual with an existing understanding of automotive electrical systems, along with the ability to test and connect wires for proper operation. To ease installation, we suggest that you **READ THIS MANUAL** before beginning your installation. This book is provided as a GENERAL GUIDELINE and the information contained herein may differ from your vehicle. **Crime stopper** Security Products, Inc. and its' vendors shall not be liable for any accident resulting from the use of this product. This system is designed to be professionally installed into a vehicle in which all systems and associated components are in perfect working condition.*

TECHNICAL SUPPORT: (800) 998-6880

Monday - Friday 8:00am - 4:30pm Pacific Std. Time
Web Site: www.crimestopper.com

CRIMESTOPPER SECURITY PRODUCTS, INC.
1770 S. TAPO STREET, SIMI VALLEY, CA. 93063

REV 07-25-2014

This device complies with FCC Rules part 15. Operation is subject to the following two conditions: (1) This device may not cause harmful interference, and (2) This device must accept any interference that may be received, including interference that may cause undesired operation. The manufacturer is not responsible for any radio or TV interference caused by unauthorized modifications to this equipment. Such modification could void the user's authority to use the equipment.

TABLE OF CONTENTS

<i>Pre-Installation Considerations</i>	3
<i>Installation Cautions & Warnings</i>	3
<i>Low Current Wiring</i>	3-8
<i>Parking Lights</i>	6
<i>Power Door Lock Wiring</i>	9-10
<i>Smart Tachless and Tach Finder Mode</i>	11
<i>Tach Programming</i>	12
<i>Diesel Glow Plug Delay</i>	13
<i>Option Programming Table</i>	14-15
<i>Option Descriptions</i>	16-20
<i>Antenna Diagram</i>	21
<i>Wiring Diagram</i>	22
<i>High Current Connector Wiring</i>	23
<i>Remote Star Diagnostics</i>	23
<i>Data Port</i>	24
<i>PC Programming Menu</i>	25
<i>Specifications</i>	26

PRE-INSTALLATION CONSIDERATIONS

BEFORE BEGINNING, check all vehicle manufacturer cautions and warnings regarding electrical service (AIR BAGS, ABS BRAKES, ENGINE / BODY COMPUTER AND BATTERY).

PLAN OUT YOUR INSTALLATION and determine most suitable locations for all components to be placed. These components include: the module itself, valet/program button, possible relays, and antenna/receiver Allow enough wire to create a service loop with strain relief, should servicing be required. This will also allow easier access and mounting.

DAMAGE to the Cool Start unit resulting from incorrect installation or failure to follow guidelines stated in this book will not be covered under warranty and will be subject to repair or replacement charges.

USE A VOLT OHM METER to test and locate all connections. Test Lights can damage a vehicle's computer systems.

ADDITIONAL PARTS, which are not included with this unit, may be needed for your particular vehicle. These items may include extra relays or Anti-Theft System Bypass modules.

INSTALLATION CAUTIONS & WARNINGS

DO NOT extend the Remote start ignition harness length. Mount the module so that main harness reaches all ignition switch wiring. Extending these wires could result in poor or improper performance.

DO NOT route any wiring that may become entangled with brake, gas pedals, steering column or any other moving parts in the vehicle.

DO NOT exceed the rated output current of any circuit on the Remote start module. Failure to observe this warning will result in damage to the unit not covered under warranty.

DO NOT remote start the vehicle in a closed garage! Make sure that the garage door is open or there is adequate ventilation. Failure to observe this rule could result in injury or death from poisonous Carbon Monoxide fumes.

WIRING Low Current 14 Pin Plug

BLACK: MAIN SYSTEM GROUND

Connect to chassis metal of the vehicle. An existing bolt or screw may provide an adequate ground, or drill a small hole, scrape away paint and attach using a sheet metal screw & star washer. This wire must be connected to a proper ground or undesirable and inconsistent operation will occur. Do not use Factory ground locations.

YELLOW: (-) HORN HONK OUTPUT (Programmable 15, 20 and 30 milliseconds)

Connect to the Negative Horn Trigger wire usually located near the steering column. If the vehicle horn circuit requires 12V, then a relay is required. RELAY WIRING: Connect the yellow wire to terminal #85, Connect relay terminals #86 and #87 to 12V constant power. Connect terminal #30 to the 12V positive Horn activation wire.

YELLOW/BLACK: (-) GROUND OUTPUT WHEN RUNNING

The Ground When Running output is used for Anti-theft and Transponder Bypass modules. It can be used for a Anti grind / Starter Disable. This wire turns on when the remote start button is pressed and stays on through the duration of the remote start. When using this wire for an Anti grind/Starter disable, an optional Relay is needed to interrupt the Starter circuit. The starter disable circuit prevents accidental grinding of the starter if key is turned too far after a remote start. This required an optional Diode, see diagrams on NEXT PAGE.

WIRING Low Current 14 Pin Plug

YELLOW/BLACK OUTPUT: Ground Out when Running (Relay and/or Module not included)

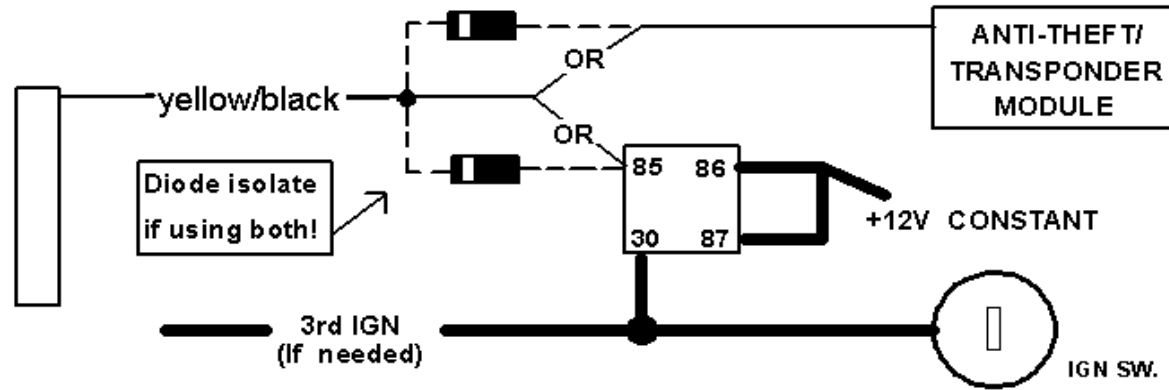

ANTI-GRIND RELAY: (Relay not included) The Brown 22 gauge wire can be programmed for Ground When Running (see next page)

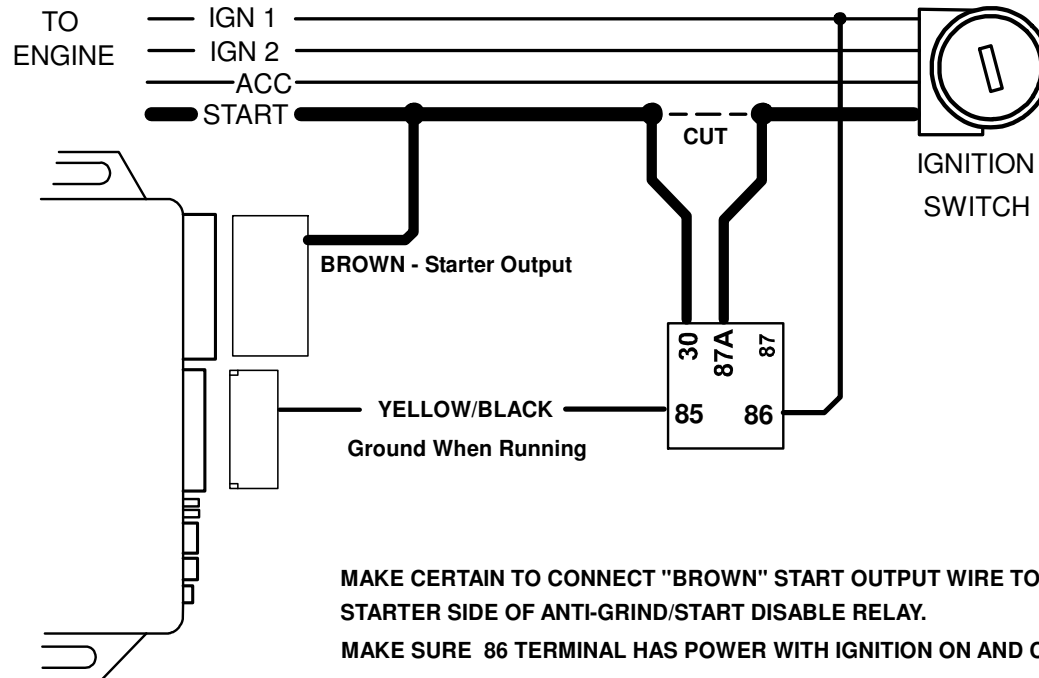

WIRING Low Current 14 Pin Plug

BROWN: (-) Dome Light Illumination or (-) Ground When Running (Option 13)

This is a programmable output that can be programmed 2 ways:

1. **30 Second dome light with unlock = Default.** The dome light turns off with ignition on or remote lock.
2. **Ground Out When Running.** Can be used for Anti-Grind relay or Key Sense wire sometimes required for OEM Disarm.

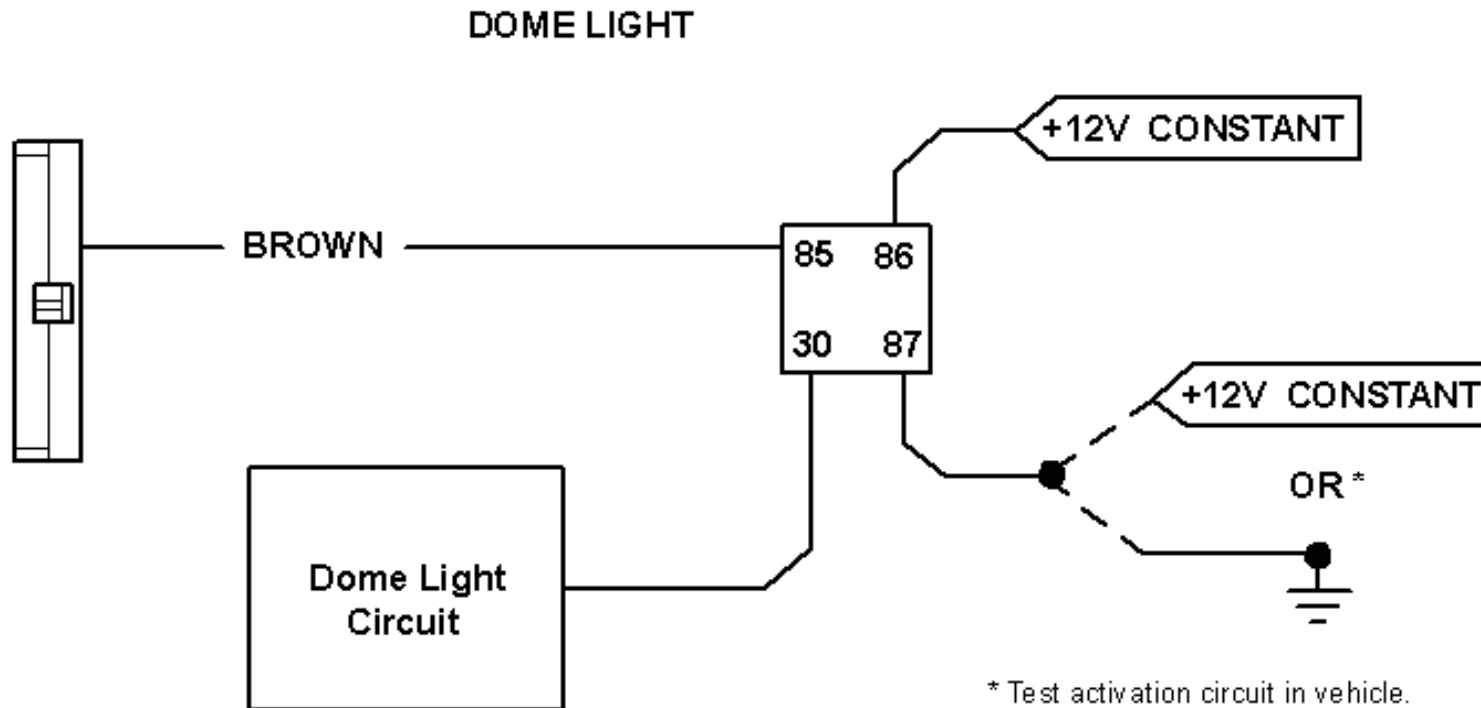

* Test activation circuit in vehicle.
Connect to +12V for Positive circuits
or Ground for Negative circuits. Relay
not included.

WIRING Low Current 14 Pin Plug

WHITE: PARKING LIGHT OUTPUT

RED/BLACK: INPUT SOURCE (12 Volts or Ground)

The Parking Light circuit can be connected up as a high current positive or negative trigger. Connect to vehicle parking light circuit at the back of light switch or if this is not possible, connect directly to one of the parking lights at the front of the vehicle. If your vehicle has a multiplex lighting system, that will require a resistor connected in series with the white wire to the light switch. Use the Negative parking light circuit for Multiplex resistor lights.

Positive Parking Lights

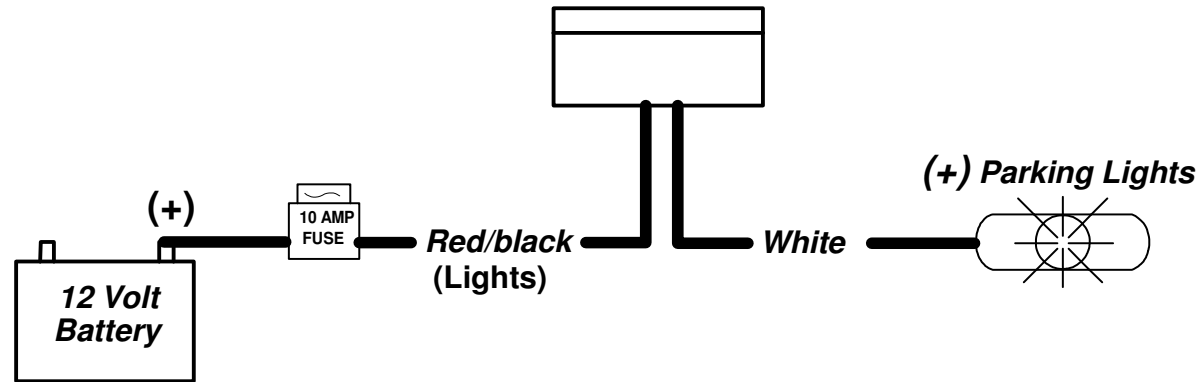

Negative Parking Lights

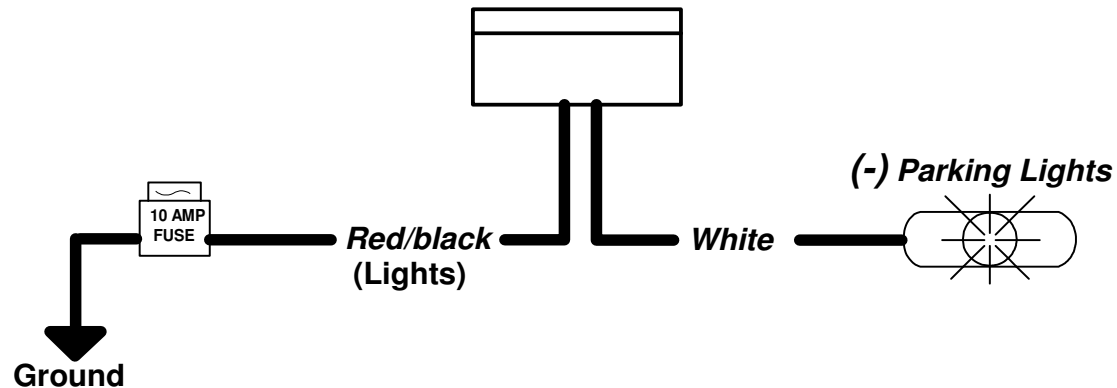

WIRING Low Current 14 Pin Plug

GRAY: (-) NEGATIVE HOOD PIN SWITCH

Connect the gray wire to a switch that is at ground when the hood is open. If an existing switch is not available, then we recommend one to be installed. When this wire is grounded, the remote start is inhibited. The unit will not attempt to start if hood is open.

PINK: (-) BRAKE RESET (Selectable Option 23)

This is a programmable output that has 4 choices;

- 1. Brake Reset = Default:** This is used for vehicles that have (-) brake pedal switch.
- 2. Start Activation Input:** This triggers a remote engine start or stop. Connect the Pink wire to an alarm or keyless entry system with a remote Aux channel to activate the Remote Start by sending a (-) momentary pulse to the **PINK** input wire. Other examples would be a GPS Tracker or Smart Phone interface.
- 3. Glow Plug Input:** Connect the Pink wire to indicator circuit that shows a (-) Signal while the WAIT TO START LAMP is on. When this wire is used, the system will wait until light turns off before attempting a remote start.
Must program Option 20-4 for maximum 20 second wait time
- 4. Handbrake Reset:** When this option is selected, the handbrake must be set for remote start. Releasing the handbrake will Abort Remote Start.

PURPLE: (+) BRAKE RESET

Connect the Purple wire to the side of brake pedal switch that shows 12 volts ONLY when pedal is depressed. This wire turns off (aborts) remote start. Allows the Ignition Key to Take Over operation of the vehicle once the driver's key is in the Ignition and turned to the ON position.

ORANGE/WHITE: (-) ACC, IGN or START OUTPUT (Option 11)

This output is selectable (-) Start, (-) Ignition or (-) ACC. **Default = (-) ACC**

BLUE/ORANGE: (-) ACC, IGN or START OUTPUT (Option 10)

This output is selectable (-) Start, (-) Ignition or (-) ACC. **Default = (-) START**

WIRING Low Current 14 Pin Plug

ORANGE / BLACK: (-) OEM DISARM OUTPUT

This wire provides a Ground pulse to disarm the vehicles' Factory anti-theft system prior to a Remote Start. Connect this wire to the vehicles' anti-theft disarm wire. This wire is sometimes found coming off the Driver's door key switch or at the Factory Anti-theft control module. This wire may not be needed when using a Bypass Module or if Factory Security only requires a door unlock pulse.

ORANGE: (-) OEM Arm (Option 12)

This is a programmable output that has 3 choices;

- 1. OEM Arm = Default:** Provides a ground pulse to arm the OEM alarm.
- 2. Pulse after Remote Start Abort:** This is used to reset Retained Accessory Power or RAP shutdown. Connect the Orange wire to the drivers door pin switch.
- 3. Pulse after Remote Start:** This feature is used to activate the defroster switch on vehicles that only work after vehicle is started.

RED /WHITE: TACHOMETER INPUT

When installing the system in Tach mode, this wire must be connected to a valid source of AC voltage. This wire allows the unit to sense the engine running and control the starter motor.

WIRING Valet Switch

PROGRAM OVERRIDE SWITCH: 2 PIN PLUG (REQUIRED FOR PROGRAMMING & LEARNING REMOTES)

This is a multi-function switch used for programming options, transmitters and valet mode. Mount the Valet/Program button in a suitable location.

POWER DOOR LOCK WIRING CONNECTOR

BLUE: (-) Negative pulse for UNLOCK

RED: 12V When using external relays (TERM 86)

GREEN: (-) Negative pulse for LOCK

DETERMINING DOOR LOCK TYPE: We recommend determining the type of locking system the vehicle has before connecting any wires. Incorrect connection may result in damage to the alarm and/or vehicle locking system.

Door lock information is provided as a guide. Your vehicle may differ.

Negative Trigger (-): Many Imports; Late model Ford & General Motors

Negative trigger door lock systems send a Negative (Ground) pulse to existing factory relays to lock and unlock the vehicle doors.

Positive Trigger (+): Many General Motors; Chrysler / Dodge / Plymouth

Positive trigger door lock systems send a Positive (12V) pulse to existing factory relays to lock and unlock the vehicle doors.

Reverse Polarity: Many older Ford/Lincoln/Mercury/Dodge/Chrysler/Plymouth and early 90's GM Trucks

Reverse Polarity systems use no relays, but instead the door lock/unlock motors are controlled directly from the lock and unlock switches in the door. The lock and unlock wires rest at Negative Ground when not in use. When the lock or unlock button is pressed, one of the circuits is "Lifted" and replaced with +12V causing a lock or unlock to occur.

Single Wire (Dual Voltage): Late model Chrysler/Dodge/Plymouth Vehicles, some 2000 GM

Dual Voltage systems have lock/unlock switches that send varying levels of Positive voltage OR Negative ground current to the SAME wire for both lock and unlock. When the vehicle's Body Computer Module (BCM) or door lock module senses different voltages on this wire, the system will either lock or unlock. Single wire door lock systems require relays and resistors.

Databus and Canbus Systems (Data Module Required)

Databus systems send low current "Data messages" to the door lock controllers on a network in order to lock and unlock the vehicle. To install aftermarket systems in these vehicles, an interface module is required that converts the regular lock/unlock pulses into "Data messages" to allow locking & unlocking. Interface modules are sold separately.

Crimestopper Door Lock Accessories:

CS-6600DLM: Dual-relay plug-in module for Reverse Polarity, Positive, or Aftermarket Motors.

CS-6500DLI: Plug-in pulse inverter that converts the Negative outputs of the system to Positive type for Positive Door Lock systems.

CS-610S1: Aftermarket door lock actuator (motor).

BASIC DOOR LOCK DIAGRAMS

NEGATIVE TRIGGER DOORLOCK WIRING

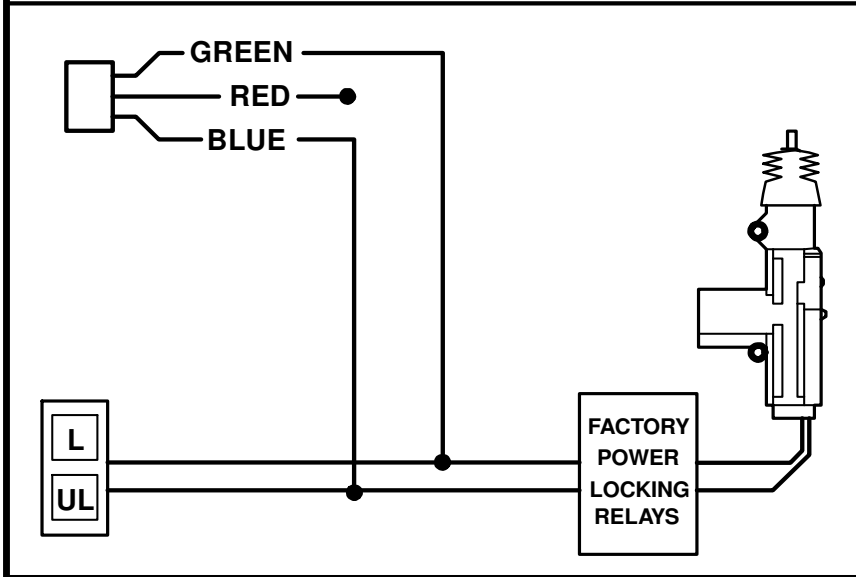

POSITIVE TRIGGER DOORLOCK WIRING

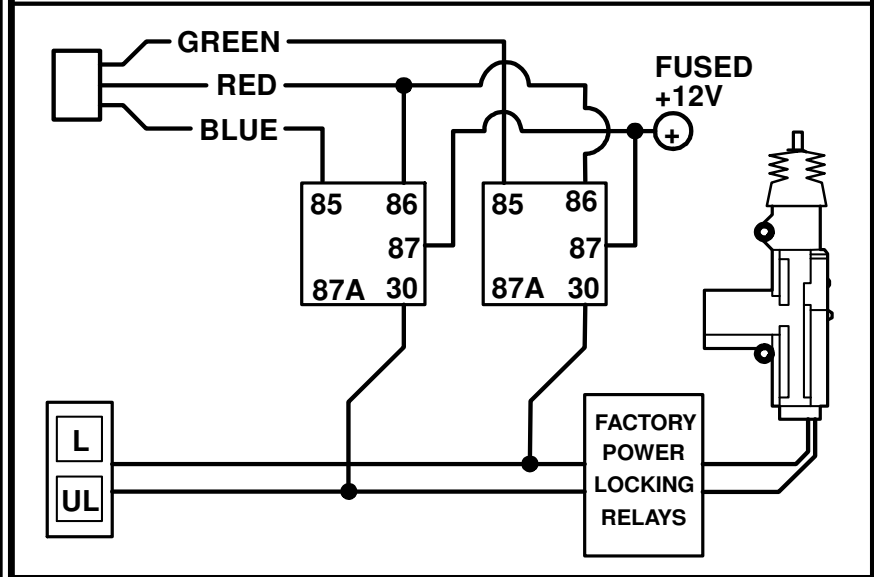

REVERSE POLARITY DOOR LOCK WIRING

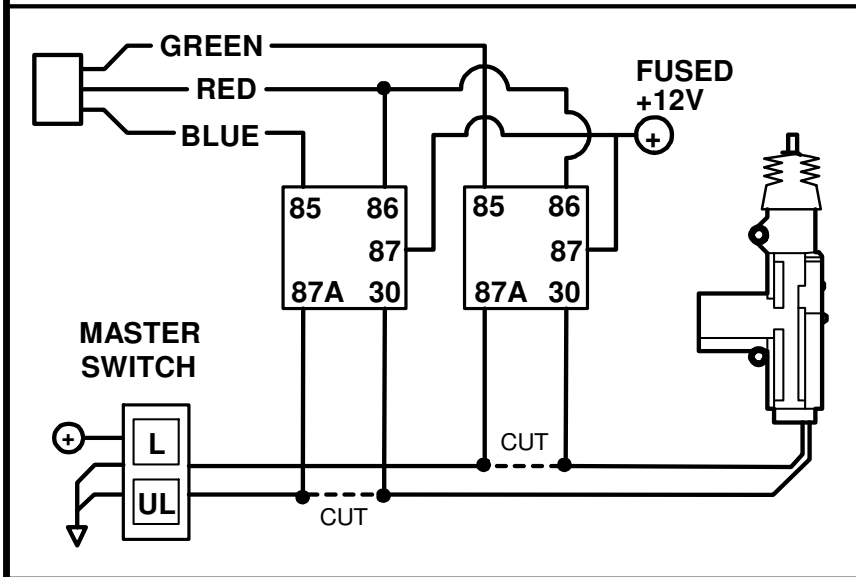

AFTERMARKET MOTOR/DOOR LOCK WIRING

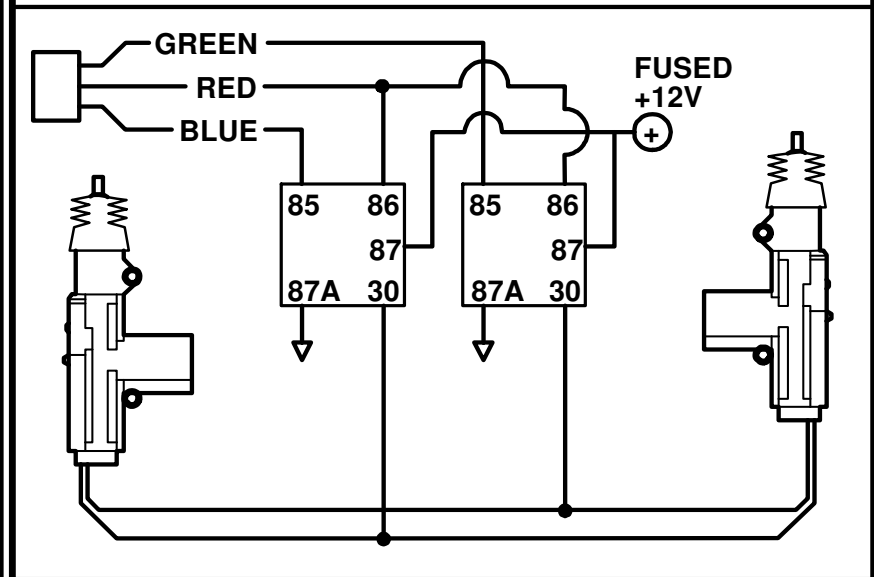

“SMART TACHLESS” MODE

Your CoolStart system includes a unique voltage monitor called “Smart Tachless” mode. This mode allows this unit to efficiently start an engine without the use of a tach signal wire. These modules actively monitor the voltage level of the vehicle to control the starter motor each time a remote start is requested.

IMPORTANT NOTES:

(1) On the rare occasion that “Smart Tachless” mode does not operate satisfactorily, change the voltage reference level as described below, or use a different mode such as “Tach” mode, or “Timed Crank” mode.

TACH FINDER & USEFUL TIPS

TACH FINDER MODE:

This Tach Finder mode can assist in locating a Tach source for your installation. When following the steps, the unit will begin to flash the parking lights if you have the Red/White wire connected to a tach source. If lights do not flash, then try another wire until you locate a tach signal that will cause the Parking lights to flash. **NOTE:** On some vehicles equipped with daytime running lights, it may be difficult to see any flashing parking lights. In this case your only notification will be the slight “ticking” sound coming from the module’s flashing light relay.

TACH FINDER STEPS:

1. Open hood (or ground the gray hood pin wire if no hood pin is installed)
2. Start Engine with the key.
3. Press the Program button for 2 seconds
4. The Parking lights will flash 10 times if the Red/White wire is connected to a valid tach source. If not, try a different tach wire.
5. Once Tach is located then turn off engine and close hood to abort (Remove gray hood pin wire from ground).
6. Now follow the Tach Programming steps.

TACH PROGRAMMING & TACH SIGNALS

INTRODUCTION

This system has 3 methods of monitoring the engine running. Option #1 controls how the system monitors the engine running.

1. **Tachless Low Level Mode - Default.** When vehicle is remote started, the battery voltage rate will go up because the Alternator starts working.
2. **Tach Reference Mode – Monitors Engine R.P.M.** - Most reliable method, see Tach programming below.
3. **Tachless High Level Mode** - When vehicle is remote started, the battery voltage rate will go up (0.5V) because the Alternator starts working.
4. **Hybrid Mode** – For electric motors that are computer controlled. This provides a 4 second (**option24-1**) crank output to activate the start sequence on Hybrid vehicle. Don't use on vehicles with gas or diesel engine, that doesn't monitor stalled engine or low battery voltage.

Tach Reference Mode: Provides reliable remote starting performance through engine speed sensing. When using Tach Reference Mode, the Red/White wire is used for Tach signal [Engine RPM] input. Most modern engines include various points where the Engine Speed [Tach] or A/C signal may be obtained. Tach Signal examples: Fuel Injection Solenoids, Negative (-) side of ignition coil, at the Distributor or Ignition Control Module, Coil Pack, Engine Computer, or Crankshaft Sensor. Sometimes an Alternator Stator pin can be used. These Tach Signal locations mentioned are provided as a guide, your vehicle may differ. Some locations will NOT be a good location for Tach source due to RF noise or Computer Data.

Note: When using a Databus module for Tach signal, don't connect up the Tach wire. This will create a conflict. The System can only use one Tach source.

TACH PROGRAMMING:

1. Red/White wire should be connected to a valid Tach source.
2. Start engine with key.
3. Press program button 5 times for option mode, then wait for 5 light flashes and/or 5 horn honks.
4. Push program button once more for option 1. (You must get one light flash and/or honk after button is pressed.)
5. Press brake pedal or Button on remote transmitter. The lights and horn will flash twice (Tach Mode) and the unit will start recording the Tach signal. The lights and or honk flash once for program confirmation.
6. If there no Tach signal, the unit will exit Tach learn mode in 20 seconds with one long flash or honk. Try another tach source or try the tach finder to locate another wire.
7. Turn ignition off to exit program mode, one long flash and or honk.

DIESEL GLOW PLUG DELAY

There are 2 methods of setting up a Glow Plug delay for Diesel vehicles.

1. Connecting the Pink wire directly to the wait to start lamp on vehicle. Option 23-3 must be selected for Pink wire = Glow Plug. Also, Option 20-4 must be selected for 20 seconds maximum wait time (default = 4 sec.). With this option selected, the starter will crank when the Wait-to-Start light turns off.
2. Option 20 – Pre-Set Diesel Glow Plug Delay, The choices are 4, 10, 15 and 20 seconds. This feature provides a solution for diesel vehicles without having to connect to the Glow Plug Wait-to-Start Circuit. This may be needed for various reasons. If your vehicle does not have a valid Wait to Start wire (LED light on instrument cluster), or you cannot locate and identify the circuit, then change your system to Diesel Glow Plug Delay. Once this mode is activated, you no longer need to connect up the Wait-to-Start wire.

NOTES: This feature is OFF by default and must be programmed before use. There are 4 different Delay times available for use: 4, 10, 15, or 20 seconds. **Default = 4 Seconds.** SEE OPTION PROGRAMMING

OPTION PROGRAMMING - 2 METHODS

This System unit has 25 programmable options to customize the system for various operating features and installer preferences. There are 2 methods of programming option for this system. You can use a PC with the optional Program Cable or the Valet program switch that comes standard with the system. Examine the chart on the following pages along with reading the descriptions that follow. You may change one option at a time, or program multiple options in one session. If you start with the lowest option and continue on to higher options, you do not need to repeat steps #1-3 each time. For example, you can change Option #2 to “ON”, then you can continue pressing the program button to get to a higher number option and change it as well. You can only go from low to higher options numbers in one session. There is a 20 second time out with no activity. The system will give one log parking light flash and or horn honk when exiting program mode.

OPTION PROGRAMMING CHART BEGINS ON NEXT PAGE

OPTION PROGRAMMING

To Engage Option Programming:

1. Turn Ignition On (must be off at least 5 seconds before turning on).
2. Within 8 seconds, press valet switch 5 times. Wait for the unit to flash the parking lights and/or horn honks 5 times to confirm entering Option Mode.
3. Push the Valet program button the number of times that corresponds to the option number desired (1-24X). You must get a light flash and/or horn honk after each button press. If the system did not flash the lights and/or honk, then it did not register your press. Each option must be changed within 20 seconds.
4. When you reach the desired option #, press the transmitter button or step on footbrake to select the option level. The lights will flash and/or honk with each option level. You will get 1, 2, 3 or 4 chirps with each press.
 - a. If there is no option level 3 or 4, then it returns the Preset value with 1 chirp.
 - b. After 20 seconds or turning ignition off, the system will have a long beep and exit the Option Mode.

OPTION PROGRAMMING

<i>Option Selection</i>		<i>Default (1 chirp)</i>	<i>Level 2 (2 chirps)</i>	<i>Level 3 (3 chirps)</i>	<i>Level 4 (4 chirps)</i>
1	<i>Engine Monitoring</i>	<i>Tachless (low level)</i>	<i>Tach</i>	<i>Tachless (high level)</i>	<i>Timed Crank (hybrid)</i>
2	<i>Auto-lock/unlock</i>	<i>OFF</i>	<i>ON</i>	<i>Lock with brake</i>	<i>Ignition Lock (no unlock)</i>
3	<i>Lock pulse timer</i>	<i>0.5 Seconds</i>	<i>3 seconds</i>	<i>Double unlock</i>	<i>“Wake Up” pulse on Unlock</i>
4	<i>Pink/white wire selection</i>	<i>IGN</i>	<i>ACC</i>	<i>START</i>	
5	<i>Data port protocol</i>	<i>Fortin</i>	<i>ADS iDatalink</i>	<i>D2D</i>	
6	<i>Gray wire selection</i>	<i>ACC</i>	<i>IGN</i>	<i>START</i>	

7	<i>Remote Start Run Time</i>	20 minutes	<i>10 minutes</i>	<i>30 minutes</i>	<i>5 minutes</i>
8	<i>Lock after Remote Start (to rearm OEM alarm system)</i>	Lock after Remote Start only	<i>OFF</i>	<i>Lock after Remote Start & Lock/Arm OEM Alarm after Remote Start Abort</i>	<i>Lock & Arm OEM Alarm after Abort only</i>
9	<i>Unlock before remote start (to disarm OEM alarm)</i>	OFF	<i>ON</i>		
10	<i>Blue/orange wire selection</i>	START	<i>IGN</i>	<i>ACC</i>	
11	<i>Orange/white wire selection</i>	ACC	<i>IGN</i>	<i>START</i>	
12	<i>Orange wire selection</i>	OEM Arm	<i>Pulse after Remote Start Abort</i>	<i>Pulse after Remote Start</i>	
13	<i>Brown wire selection</i>	Dome Light	<i>Ground when Running</i>		
14	<i>Idle Down Run Time</i>	20 Minutes	<i>10 Minutes</i>	<i>30 Minutes</i>	<i>Infinity Run</i>
15	<i>Horn Chirp Confirmation (lock/unlock)</i>	OFF	<i>ON</i>		
16	<i>3 Horn Chirps with Remote Start Activation</i>	OFF	<i>ON</i>		
17	<i>Horn Pulse (Chirp)</i>	20 milliseconds	<i>15 milliseconds</i>	<i>30 milliseconds</i>	
18	<i>Crank Time</i>	0.8 Seconds	<i>1 Seconds</i>	<i>1.2 Seconds</i>	<i>1.4 Seconds</i>
19	<i>30 Second Park Lights with Unlock</i>	ON	<i>OFF</i>		
20	<i>Diesel Glow Plug Delay</i>	4 Seconds	<i>10 Seconds</i>	<i>15 Seconds</i>	<i>20 Seconds</i>
21	<i>Turbo Timer</i>	OFF	<i>1 minute</i>	<i>3 minutes</i>	<i>5 minutes</i>
22	<i>Timed Self Start Mode</i>	OFF	<i>4 hours</i>	<i>2 hours</i>	<i>3 hours</i>
23	<i>Pink wire selection</i>	Brake Reset	<i>Start Activation</i>	<i>Glow plug</i>	<i>Handbrake</i>
24	<i>Hybrid crank time</i>	4 Seconds	<i>Same as option18</i>		
25	Reset Options to Default	Reset Options 1 thru 24 (1 Horn Chirp and Parking Light Flash)			

OPTION DESCRIPTIONS

1. Engine Monitoring:

This option controls how the system monitors the engine running. You can program for Tachless mode that monitors battery voltage, Tach mode in which the unit uses a Tach signal (RPM) or for Timed Crank as an alternative. There are 4 choices for this option:

1. **Tachless (low level) – Default.** When vehicle is remote started, the battery voltage rate will go up because the Alternator starts working.
2. Engine R.P.M. (Tach) - Most reliable method. Tach must be programmed for this option to work.
3. **Tachless (high level)** . When vehicle is remote started, the battery voltage rate must go up 0.5 v
4. Hybrid Mode – For Push to Start (PTS) vehicles. This provides a 4.0 second (**option24-1**) crank output to activate the start sequence on PTS or Hybrid vehicle. Option #18 allows you to shorten starter crank time if necessary. **But set Hybrid crank time to option 24-2**

2. AUTO LOCK and UNLOCK with IGNITION:

This feature controls whether the doors will automatically lock when the ignition is turned on and unlock when the ignition is turned off. There are 4 choices:

1. **OFF = No Lock or Unlock with Ignition - Default OFF**
2. Ignition ON = Lock, Ignition OFF = Unlock
3. Lock with Brake = Turn ignition on and press brake pedal, the doors will lock, Ignition OFF = Unlock
4. Ignition ON = Lock, Ignition OFF = not Unlock

3. DOOR LOCKS:

This option sets how the door lock circuit works. There are 4 choices:

1. **0.5 Second Lock and Unlock – Default.**
2. 3 Second Lock and Unlock - For older European vehicles that require a long lock and unlock pulse to operate Vacuum door lock systems.
3. Double Unlock – This feature may be required to interface with a factory alarm or keyless entry system. The first pulse disarms the factory alarm; the 2nd pulse unlocks the doors.
4. “Wake Up” pulse on Unlock - 0.5 second unlock pulse along with Ignition, Accessory, Disarm and (-) RUN to wake up a BCM. This feature is required on new vehicles that disarm the factory alarm by turning on the ignition key.

OPTION DESCRIPTIONS

4. PINK / WHITE WIRE SELECTION:

This option controls the Pink / White wire function.

1. **Pink / White = Ignition – Default.**
2. Pink / White = Accessory
3. Pink / White = Start

5. DATA PORT PROTOCOL: *Default = FORTIN*

This option controls the Data Port Protocol for ADS / FORTIN Series modules or D2D Series modules. The default is set for *ADS IDATALINK* Series Protocol. This option has no effect on conventional wiring of Bypass modules. Both Data Protocols are 2-Way communication.

6. GRAY WIRE SELECTION:

This option controls the Gray wire function.

1. **Gray = Accessory – Default**
2. Gray = Ignition
3. Gray = START

7. REMOTE START ENGINE RUN TIME: Set engine run time for 10, 20, 30 or 5 minutes as desired.

Default = 20 minutes

8. LOCK with REMOTE START:

This option controls whether the unit will automatically lock during and after a remote Start abort or time-out. There are 4 choices for this option:

1. **Lock after Remote Start Only – Default.**
2. OFF
3. Lock with Remote Start and Lock / Arm after Remote Start Abort
4. Lock and Arm with Remote Start Abort only

9. UNLOCK BEFORE REMOTE START:

This option is used to disarm an OEM Alarm System before Remote Start. **Default = OFF**

OPTION DESCRIPTIONS

10 . BLUE/ORANGE WIRE SELECTION:

This option controls the Blue/orange wire function.

1. **Blue/orange = Start – Default**
2. Blue/orange = Ignition
3. Blue/orange = Accessory

11 . ORANGE/WHITE WIRE SELECTION:

This option controls the Orange/white wire function.

1. **Orange/white = Accessory – Default**
2. Orange/white = Ignition.
3. Orange/white = Start

12. ORANGE WIRE SELECTION:

There are 3 choices for this option.

1. **Orange = OEM Arm – Default**
2. Orange = Pulse after Remote Start Abort: This is used to reset Retained Accessory Power or RAP shutdown.
3. Orange = Pulse after Remote Start. This feature is used to activate the defroster switch on vehicles that only work after vehicle is started.

13. BROWN WIRE SELECTION: DOME LIGHT, GWR (status output)

This output that can be programmed 2 ways:

1. **30 Second Dome Light with Unlock = Default.** The dome light turns off with ignition on or remote lock.
2. Ground Out When Running.

14. IDLE DOWN RUN TIME:

This feature allows the remote starter to take over operation of a parked vehicle when the ignition key is removed and you exit the vehicle. The vehicle will remain running for the programmed time or until canceled. The choices are: 10, 20, 30 minutes or Infinity Run. **Default = 20 minutes.**

OPTION DESCRIPTIONS

15. HORN CHIRP Confirmation with LOCK or UNLOCK

This option allows the system to chirp the vehicle horn for Lock and Unlock confirmation. The horn output must be connected to use this feature. **Default = OFF.**

Lock = 1 Chirp

Unlock = 2 Chirps

16. HORN CHIRPS with REMOTE START ACTIVATION:

This option allows the unit to provide 3 short chirps for audible confirmation of a remote start. The horn output wire must be connected for this feature. **Default = OFF.**

17. HORN PULSE DURATION:

This option allows adjustment the "CHIRP" pulse duration of the car horns. The choices are 15, 20 or 30 milliseconds.

18. STARTER CRANK TIME: **Default = 0.8 seconds**

This option controls the Starter Cranking time. The choices are 0.8, 1, 1.2 & 1.4 seconds

TIMED START, use Hybrid Mode (option 1-4) with this option to set a fixed crank time. Please Note: In Hybrid Mode there is only 1 start attempt and the ignition is left on.

19. PARK LIGHTS ON 30 SECONDS with UNLOCK:

Keeps parking lights on with remote unlock to assist in locating and providing illumination near your vehicle when approaching at night for safety. The parking lights turn off when the ignition is turned on. **Default = ON.**

20. DIESEL GLOW PLUG DELAY:

The choices are 4, 10, 15 and 20 seconds. This feature provides a solution for diesel vehicles without having to connect to the Glow Plug Wait-to-Start Circuit. This may be needed for various reasons. If your vehicle does not have a valid Wait to Start wire (LED light on instrument cluster), or you cannot locate and identify the circuit, then change your system to Diesel Glow Plug Delay. Once this mode is activated, you no longer need to connect up the Wait-to-Start wire.

OPTION DESCRIPTIONS

21. TURBO TIMER:

The optional Turbo Timer mode allows the Cool Start system to keep a Turbo or Turbo Diesel vehicle running for 1, 3 or 5 minutes [selectively] after you remove the key and exit the vehicle. This is handy for turbo cool-down without the need for expensive turbo timers. The **Default = OFF**.

22. TIMED SELF START MODE: **Default = OFF**

This option allows the system to Self Start every 2, 3 or 4 hours.

23. PINK WIRE SELECTION:

This is a programmable output that has 4 choices;

1. **Pink = Brake Reset - Default:** This is used for vehicles that have (-) brake pedal switch.
2. Pink = Start Activation Input. This triggers a remote engine start or stop. Connect the Pink wire to an alarm or keyless entry system with a remote Aux channel to activate the Remote Start by sending a (-) momentary pulse to the PINK input wire. Other examples would be a GPS Tracker or Smart Phone interface.
3. Pink = Glow Plug Input. Connect the Pink wire to indicator circuit that shows a (-) Signal while the WAIT TO START LAMP is on. When this wire is used, the system will wait until light turns off before attempting a remote start.
4. Pink = Handbrake Reset. When this option is selected, the handbrake must be set for remote start. Releasing the handbrake will Abort Remote Start

24. HYBRID STARTER CRANK TIME:

This option control the Hybrid crank time:

24-1 Starter Crank Time = **4 Seconds – Default**

Option 24-2: Same as option 18 setting (0.8, 1.0, 1.2, or 1.4)

25. OPTION RESET: (RESTORE TO DEFAULT)

This option restores all programmable options 1 thru 24 to factory default. The horn will chirp once, the parking light flash once and all values will be reset to factory original settings.

CONNECTOR PLUG DIAGRAM

ANTENNA MODULE: For optimum range and performance, the antenna should be located high up on the front windshield glass. For example: behind the rearview mirror. Note: Window tints or Films may decrease the range of the system. The mounting surface for the antenna should be clean and dry.

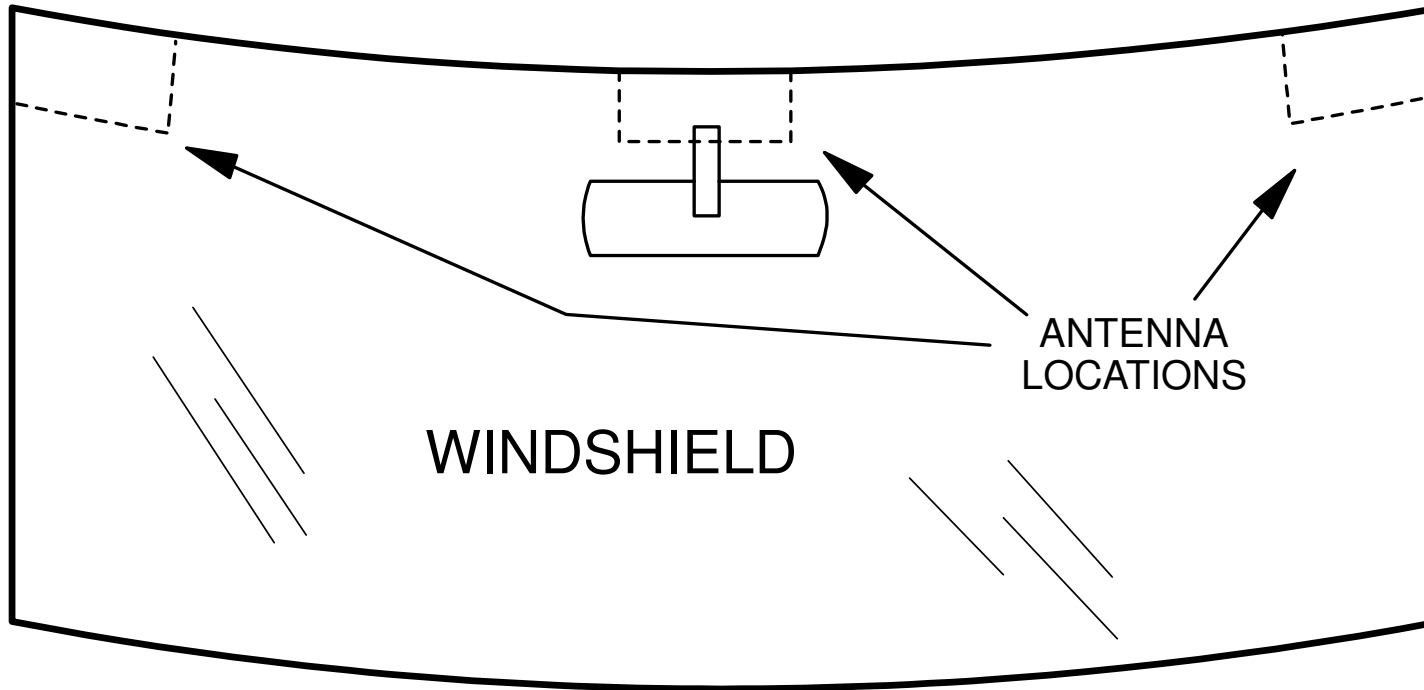

WIRING DIAGRAM

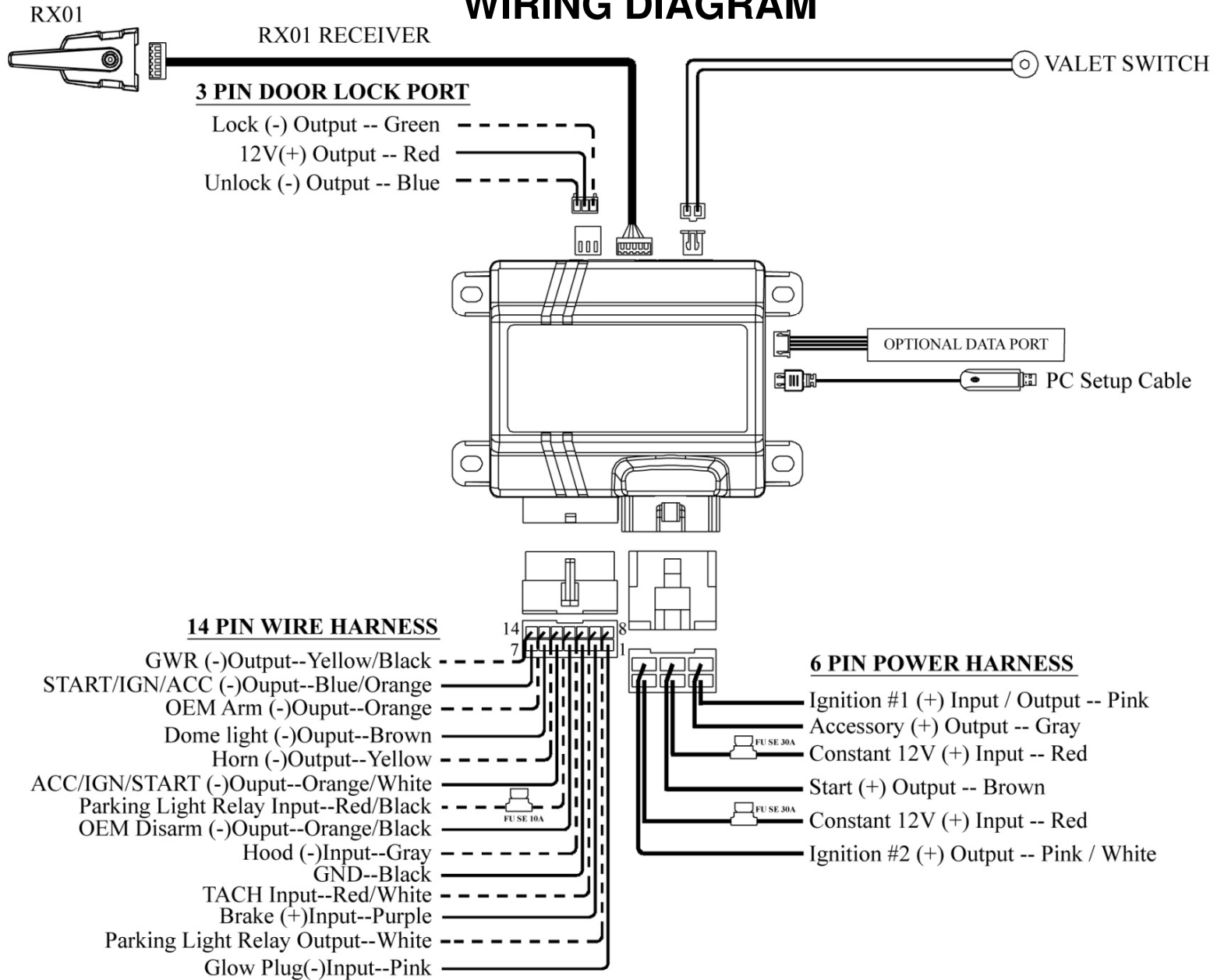

HIGH CURRENT 6-PIN HIGH-CURRENT CONNECTOR

(2) RED: 12V POWER INPUT WIRES (30A Fused):

Connect to both of these leads to 12V Constant Power. We recommend the BATTERY POSITIVE TERMINAL.

BROWN: 12V STARTER OUTPUT 30A:

Connect to circuit in the vehicle that has power ONLY while the STARTER MOTOR is CRANKING.

GRAY: 12V MULTIFUNCTION OUTPUT 20A (Option 6):

This is an optional multi-function output wire that can be configured as a Second IGN, ACC or STARTER output. Use Option #6 to select ACC, IGN or STARTER. **DEFAULT = ACCESSORY.**

PINK: 12V IGNITION OUTPUT 20A:

Connect the circuit in the vehicle that provides true Ignition Power for systems such as Spark and Fuel. Typically, this wire turns ON with the second position of the key, STAYS ON WHEN CRANKING, and continues ON as the vehicle runs.

PINK / WHITE: 12V MULTIFUNCTION OUTPUT 20A (Option 4):

This is an optional multi-function output wire that can be configured as a Second IGN, ACC or STARTER output. Use Option #4 to select ACC, IGN or STARTER. **DEFAULT = IGNITION.**

REMOTE START DIAGNOSTICS

If the system flashes the LED and Parking Lights one to six times and doesn't attempt remote start. The LED will continue to flash the error code until the ignition is turned on, it means the following:

- 1 Parking Light Flash (1 LED Flash) = Problem with Brake Switch.
- 2 Parking Light Flashes (2 LED Flashes) = Problem with Hood Switch.
- 3 Parking Light Flashes (3 LED Flashes) = Tach Problem.
- 4 Parking Light Flashes (4 LED Flashes) = Voltage Sense Problem, battery not charging or too low.
- 5 Parking Light Flashes (5 LED Flashes) = Problem with (-) Brake Input.
- 6 Parking Light Flashes (Solid LED) = Valet Service Mode.

DATA PORT

This unit includes DP Technology that will allow you to directly Plug-In our Data Port. There are 3 types of Protocol, ADS iDatalink series, Fortin series and d2d series modules. The default is set for Fortin series Protocol. Please refer to Databus module manual for detail instructions. The Data Port Protocol must be programmed for the correct module.

See Option # 5 for programming Data Port

Some vehicles require a Databus Module to Bypass the factory Immobilizer and operate the keyless entry

Databus modules are used to communicate with the vehicles computer at the OBD2 Data connector or Canbus wires. This reduces installation error. Crimestopper Systems with DP Series have a direct Data Port Plug-In for the Databus bypass module. This eliminates conventional wiring between the Alarm/Remote Starter and the bypass interface module.

PC SETUP Optional Cable Required

You can change all options in the Program menu by using a PC. You can run program directly from CD or copy the AM351_.exe file on your PC to run program.

To Run Program:

- 1、 The remote start module must be connected to power and ground to run program.
- 2、 Plug in programming cable to spare USB connector on your PC and to the remote start module (see wiring diagram).
- 3、 Click on the AM351_.exe file to load program. You will see the PC Programming Menu on next page.
- 4、 Selected the correct COM port.
- 5、 Click Request button, the program will read the current settings of the system.
- 6、 Change any options in Programming Menu to desired level.
- 7、 Click Apply button to Finalize Programming.
- 8、 Click Default button to restore all options back to factory Default value.

PC PROGRAMMING MENU

AM351

COM:  Exit

Engine Monitoring	Tachless (low level)	Idle Down Run Time	20 Minutes
Auto-lock/unlock	OFF	Horn Chirp Confirmation (lock/unlock)	OFF
Lock pulse timer	0.5 second	3 Horn Chirps on Remote Start	OFF
Pink/white wire selection	IGN	Horn Pulse (Chirp)	20 milliseconds
Data port protocol	Fortin	Crank Time	0.8 Second
Gray wire selection	ACC	30 Sec Park Lights with unlock	ON
Remote start time	20 minutes	Diesel Glow Plug Delay	4 Seconds
Lock after Remote Start	Lock after remote start c	Turbo Timer	OFF
Unlock before remote start	OFF	The interval time for timer starter	OFF
Blue/orange wire Output(-)	START	Pink wire selection	Brake reset
Orange/white wire	ACC	Hybrid crank time	4 seconds
Orange wire Output	OEM Arm		
Brown wire Output	Dome light		

Default Apply Request **Exit**

SPECIFICATIONS

ELECTRICAL

DC Supply voltage	12V
DC Tolerance voltage	9V~16V
Current (With RF)	<25mA
Current (Without RF)	<10mA

RF PARAMETERS—RX01FM

Frequency	433MHz
Work current	<20mA

T34AM-1 WAY PARAMETERS

Battery voltage	2*3V
Battery life	6 months
Static current	<3uA
Work current	<15mA

T34FM-2 WAY PARAMETERS

Battery voltage	1*3V
Battery life	6 months
Static current	<3uA
transmit current	<78mA
Receive current	<25mA

changes or modifications not expressly approved by the party responsible for compliance could void the user's authority to operate the equipment.

This equipment has been tested and found to comply with the limits for a Class B digital device, pursuant to Part 15 of the FCC Rules. These limits are designed to provide reasonable protection against harmful interference in a residential installation. This equipment generates, uses and can radiate radio frequency energy and, if not installed and used in accordance with the instructions, may cause harmful interference to radio communications. However, there is no guarantee that interference will not occur in a particular installation.

If this equipment does cause harmful interference to radio or television reception, which can be determined by turning the equipment off and on, the user is encouraged to try to correct the interference by one or more of the following measures:

- Reorient or relocate the receiving antenna.
- Increase the separation between the equipment and receiver.
- Connect the equipment into an outlet on a circuit different from that to which the receiver is connected.
- Consult the dealer or an experienced radio/TV technician for help.

CRIMESTOPPER



www.crimestopper.com

Phone (800) 998-6880

FAX (805) 581-9500

© 2014 Crimestopper Security Products