

INSTRUCTIONS FOR OPERATION

SETTING THE OPERATING CONTROLS

1. This unit operates on a 12 volts battery (not included).
To prevent possible damage if the battery should leak , be sure to remove the battery when the unit is not use .
2. Store the controller away from excess heat or humidity .
3. This remote control unit is required with 2¹⁶ code combinations. To prevent possible interference from or to other remote units such as garage door openers, car alarm or security system .
4. Operation buttons on the panel of transmitter .

HI key – For fan High speed .
MED key – For fan Medium speed .
LOW key – For fan Low speed .
FAN OFF key – For fan speed off .
REV key – For fan speed Reverse .
UP LIGHT CONTROL key – For light brightness and ON/OFF control .
DOWN LIGHT CONTROL key – For light brightness and ON/OFF control .

5. Start the fan :
Press the selected speed button to run the fan at the desired .
6. Turn off the fan :
Press the OFF button .
7. Light control :
Turn the light on or off by only touching the **LIGHT CONTROL** button .
Keep pressing the button in excess of 0.7 second it becomes a dimmer ,
the light varies cyclically in 0.8 second .
One of the important feature of this control is **AUTO-RESUME** . After power on , it allows the light return to where it was off .

INSTRUCTIONS FOR INSTALLATION AND OPERATION OF FAN SPEED CONTROLLER

1.SAFETY PRECAUTIONS :

- 1.WARNING : HIGH VOLTAGE : Disconnect source of electrical power by removing fuse or switching off circuit breakers.
- 2.Electrical source and fan must be 120 volt, 60/50Hz. Maximum fan motor amps:1
Maximum light watts:360-incandescent (or Ballast 300VA)
- 3.Household electrical power can cause serious injury or death.

2. Setting the code on your new transmitter .

Within 60 seconds of turning the AC power on, press and hold the OFF/STOP button for 5 seconds. The receiver will then lock in the chosen frequency. If your fan has a light it will blink twice, for fans without lights check operation using the transmitter

3.CONNECTING THE TRANSMITTER

1.Remove wall plate, disconnect and remove the toggle switch from wall junction box. Using the wire nuts provided, make the electrical connections to the new Transmitter unit as shown in figure 2.

2.If your outlet box has a ground wire (green or bare copper)connect the wall transmitter's ground wire to it; otherwise connect the wall transmitter's ground wire directly to one of the screws from the outlet box.

3.Carefully tuck wire connections inside wall switch box. Secure Transmitter with the two screws (provided). Attach wall plate over control unit with the 2 screws previously removed(FIG 3)

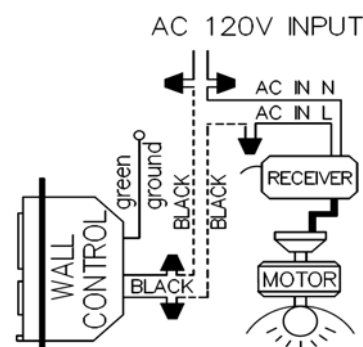

FIG.2

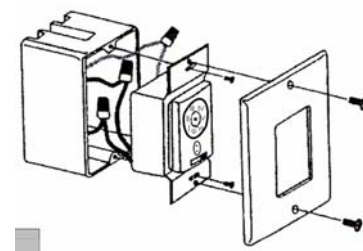

FIG.3

NOTICE : The changes or modifications not expressly approved by the party responsible for compliance could void user's authority to operate the equipment .

This device complies with part 15 of the FCC Rules. Operations is subject to the following two conditions: (1)this device may not cause harmful interference, and (2) this device must accept any interference received, including interference that may cause undesired operation.

Federal Communications Commission Radio Frequency Interference Statement

This equipment has been tested and found to comply with the limits for a Class B Digital Device, pursuant to Part 15 of the FCC Rules. These limits are designed to provide reasonable protection against harmful interference in a residential installation.

This equipment generates, uses and can radiate radio frequency energy and, if not installed and used in accordance with the instruction may cause harmful interference to radio communication. However, there is no guarantee that interference will not occur in a particular installation.

If this equipment does cause harmful interference to radio or television reception, which can be determined by turning the equipment off and on, the user is encouraged to try to correct the interference by one or more of the following measures:

- Reorient or relocate the receiving antenna.
- Increase the separation between the equipment and receiver.
- Connect the equipment into an outlet on a circuit different from that to which the receiver is connected.
- Consult the dealer or an experienced radio / TV technician for help.