

FCC APPLICATION FOR CERTIFICATION

FOR

RHINE ELECTRONIC CO., LTD.

NO. 2, Lane 168, Chung Teh Road,
Taichung, Taiwan, R.O.C.

FCC ID.:CHQ8BT7067R

July, 1998

Submitted to:

Federal Communications Commission
EQUIPMENT APPROVAL SERVICES
P.O. BOX 358315
Pittsburgh, PA 15251-3315

Exhibit C

Measurement Rerort

RHINE ELECTRONIC CO., LTD.

FCC ID.:CHQ8BT7067R

Receiver of Remote Control

FCC Part 15 Subpart B

EMI TEST REPORT

of

E.U.T. : Receiver of Remote Control

FCC ID. : CHQ8BT7067R

MODEL : 7067R

Receiving Frequency : 303.875 MHz

for

APPLICANT : RHINE ELECTRONIC CO., LTD.

ADDRESS : NO. 2, LANE 168, CHUNG TEH ROAD,
TAICHUNG, TAIWAN, R.O.C.

Test Performed by

ELECTRONICS TESTING CENTER, TAIWAN

NO. 8 LANE 29, WENMING ROAD,
LOSHAN TSUN, KWEISHAN HSIANG,
TAOYUAN, TAIWAN, R.O.C.

Tel:(03)3280026-32

Fax:(03)3280034

Report Number : ET87R-06-018

TEST REPORT NOTIFICATION

Applicant : RHINE ELECTRONIC CO., LTD.
NO. 2, LANE 168, CHUNG TEH ROAD, TAICHUNG,
TAIWAN, R.O.C.

Manufacturer : RHINE ELECTRONIC CO., LTD.
NO. 5, SEC. 1, DA-FU RD., TAN-TZN HSIANG,
TAICHUNG HSIEN, TAIWAN, R.O.C.

Description of EUT :
a) Type of EUT : Receiver of Remote Control
b) Trade Name : N/A
c) Model No. : 7067R
d) Receiver Type : Super-regeneration
e) FCC ID : CHQ8BT7067R
f) Receiving Frequency : 303.875 MHz
g) Power Supply : AC 120V, 60Hz

Regulation Applied : FCC Rules and Regulations Part 15 Subpart B (1996)

I HEREBY CERTIFY THAT; The data shown in this report were made in accordance with the procedures given in ANSI C63.4 and the energy emitted by the device was founded to be within the limits applicable. I assume full responsibility for accuracy and completeness of these data.

Issued Date : JUN. 26, 1998

Test Engineer : Tien Lu Liao
(Tien Lu Liao)

Approve & Authorized Signer : Will Yauo
Will Yauo, Supervisor
EMI Test Site of ELECTRONICS
TESTING CENTER, TAIWAN

<i>Table of Contents</i>	<i>Page</i>
1. GENERAL INFORMATION.....	1
1.1 PRODUCT DESCRIPTION.....	1
1.2 CHARACTERISTICS OF DEVICE.....	1
1.3 TEST METHODOLOGY.....	1
1.4 TEST FACILITY.....	1
2. DEFINITION AND LIMITS.....	2
2.1 DEFINITION.....	2
2.2 LIMITATION.....	2
2.3 LABELING REQUIREMENT.....	3
2.4 USER INFORMATION.....	3
3. RADIATED EMISSION MEASUREMENT.....	4
3.1 APPLICABLE STANDARD.....	4
3.2 MEASUREMENT PROCEDURE.....	4
3.3 RADIATED EMISSION DATA.....	6
3.4 FIELD STRENGTH CALCULATION.....	8
3.5 RADIATED EMISSION MEASURING EQUIPMENT.....	8
3.6 RADIATED MEASUREMENT PHOTOS.....	9
4. CONDUCTED EMISSION MEASUREMENT.....	10
4.1 STANDARD APPLICABLE.....	10
4.2 MEASUREMENT PROCEDURE.....	10
4.3 CONDUCTED EMISSION DATA.....	11
4.4 RESULT DATA CALCULATION.....	16
4.5 CONDUCTED EMISSION MEASURING EQUIPMENT.....	16
4.6 CONDUCTED EMISSION MEASURING PHOTOS.....	17

1. GENERAL INFORMATION

1.1 Product Description

- a) Type of EUT : Receiver of Remote Control
- b) Trade Name : N/A
- c) Model No. : 7067R
- d) Type of Receiver : Super-regeneration
- e) FCC ID : CHQ8BT7067R
- f) Receiving Frequency : 303.875 MHz
- g) Power Supply : AC 120V, 60Hz

1.2 Characteristics of Device

This is a remote controller for electric fan which can control fan speed and light.

1.3 Test Methodology

Both conducted and radiated testing were performed according to the procedures in section 12.1 of ANSI C63.4(1992).

For detail procedures, please see each measuring item.

1.4 Test Facility

The open area test site and conducted measurement facility used to collect the radiated data is located on the roof top of Building at No.34, 5 Lirn, Din Fu Tsun, Lin Kou, Taipei, Taiwan, R.O.C.

This site has been fully described in a report submitted to your office, and accepted in a letter dated Feb. 10 , 1997.

2. DEFINITION AND LIMITS

2.1 Definition

Unintentional radiator:

A device that intentionally generates and radio frequency energy for use within the device, or that sends radio frequency signals by conduction to associated equipment via connecting wiring, but which is not intended to emit RF energy by radiation or induction.

2.2 Limitation

(1) Conducted Emission Limits :

According to 15.107 , Except for Class A digital devices, for equipment that is designed to be connected to the public utility (AC) power line, the radio frequency voltage that is conducted back onto the AC power line on any frequency or frequencies within the band 450 kHz to 30 MHz shall not exceed 250 microvolts. Compliance with this provision shall be based on the measurement of the radio frequency voltage between each power line and ground at the power terminals.

Class B Line Conducted Emission Limits :

Frequency MHz	Emissions μV	Emissions dB μV
0.45 - 30.0	250	48.0

(2) Radiated Emission Limits :

According to 15.109 ,Except for Class A digital devices, the field strength of radiated emissions from unintentional radiators at a distance of 3 meters shall not exceed the following values:

Class B Radiated Emission Limits :

Frequency MHz	Distance Meters	Radiated dB $\mu V/m$	Radiated $\mu V/m$
30 - 88	3	40.0	100
88 - 216	3	43.5	150
216 - 960	3	46.0	200
above 960	3	54.0	500

2.3 Labeling Requirement

The device shall bear the following statement in a conspicuous location on the device :

This device complies with part 15 of the FCC Rules. Operation is subject to the following two conditions : (1) This device may not cause harmful interference, and (2) this device must accept any interference received, including interference that may cause undesired operation.

2.4 User Information

The users manual or instruction manual for an intentional or unintentional radiator shall caution the user that changes or modifications not expressly approved by the party responsible for compliance could void the user's authority to operate the equipment.

3. RADIATED EMISSION MEASUREMENT

3.1 Applicable Standard

For unintentional radiator, the radiated emission shall comply with § 15.109(a).

3.2 Measurement Procedure

1. Setup the configuration per figure 1 and 2 for frequencies measured below and above 1 GHz respectively.
2. For emission frequencies measured below 1 GHz, a pre-scan is performed in a shielded chamber to determine the accurate frequencies of higher emissions will be checked on a open test site. As the same purpose, for emission frequencies measured above 1 GHz, a pre-scan also be performed with a 1 meter measuring distance before final test. For super-regeneration receiver, there is tow mode of measurement, one is stand-by without a TX signal (CW), and the other is receiving a proper TX signal.
3. For emission frequencies measured below and above 1 GHz, set the spectrum analyzer on a 100 kHz and 1 MHz resolution bandwidth respectively for each frequency measured in step 2.
4. The search antenna is to be raised and lowered over a range from 1 to 4 meters in horizontally polarized orientation. Position the highness when the highest value is indicated on spectrum analyzer, then change the orientation of EUT on test table over a range from 0 ° to 360 ° with a speed as slow as possible, and keep the azimuth that highest emission is indicated on the spectrum analyzer. Vary the antenna position again and record the highest value as a final reading. A RF test receiver is also used to confirm emissions measured.
5. Repeat step 4 until all frequencies need to be measured were complete.
6. Repeat step 5 with search antenna in vertical polarized orientations.
7. Check the three frequencies of highest emission with varying the placement of cables associated with EUT to obtain the worse case and record the result.

Figure 1 : Frequencies measured below 1 GHz configuration

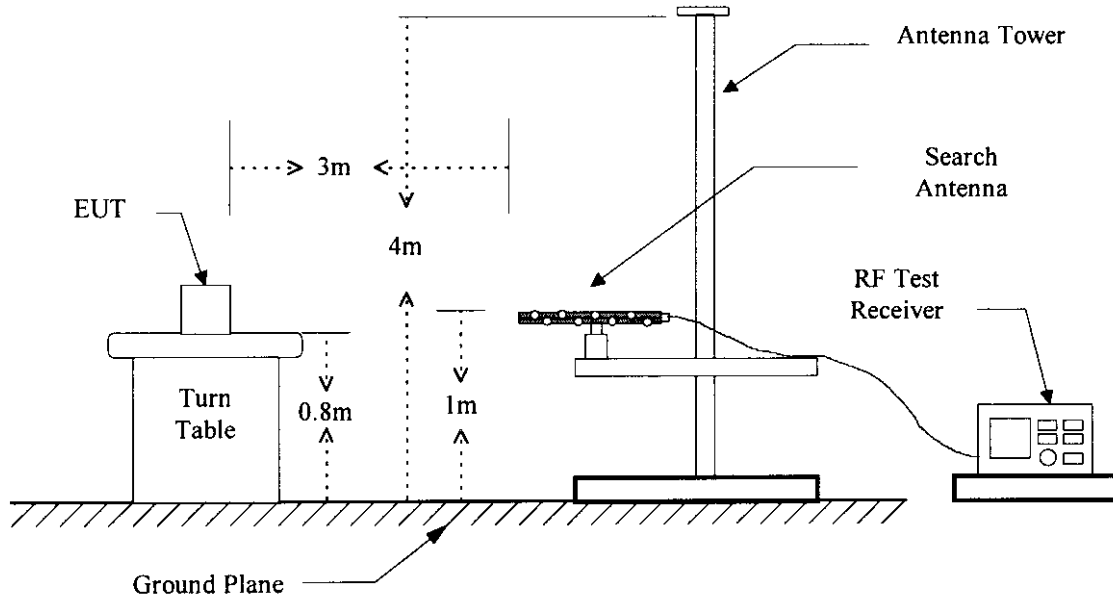
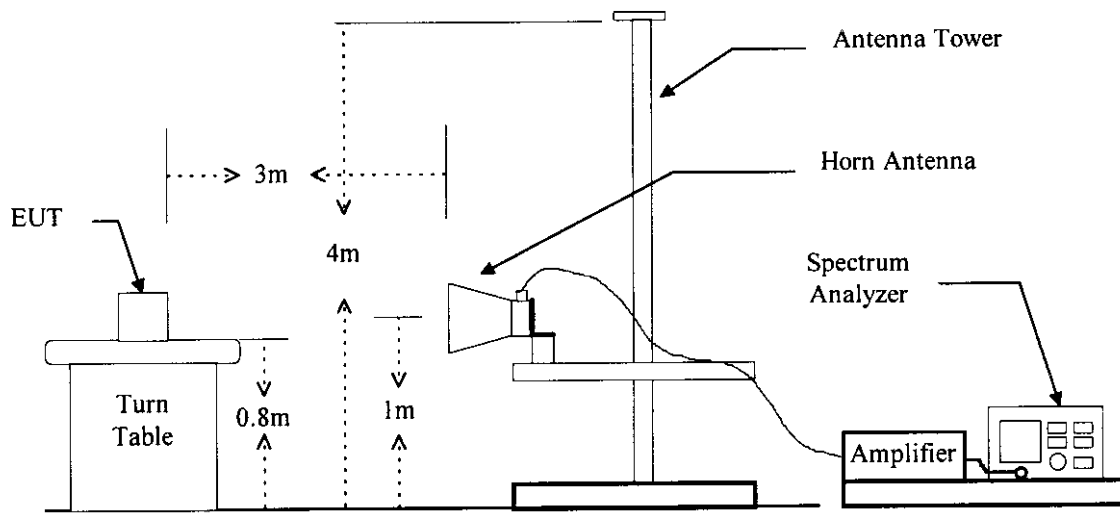

Figure 2 : Frequencies measured above 1 GHz configuration



3.3 Radiated Emission Data**a. TX Off**

Operation Mode : Weak Light

Test Date : JUN. 06, 1998

Temperature : 23 °C

Humidity : 68%

Frequency (MHz)	Ant-Pol H/V	Meter Reading (dBuV)	Corrected Factor (dB)	Result @3m (dBuV/m)	Limit @3m (dBuV/m)	Margin (dB)	Table Degree (Deg.)	Ant. High (m)
300.121	H	43.3	-7.0	36.3	46.0	-9.7	180	1.70
601.060	V	30.9	-4.4	26.5	46.0	-19.5	180	1.50
899.800	V	30.4	2.1	32.5	46.0	-13.5	180	1.80
1200.484	H/V	---	-8.8	---	54.0	---	---	---
1500.605	H/V	---	-7.5	---	54.0	---	---	---
1800.726	H/V	---	-5.8	---	54.0	---	---	---
2100.847	H/V	---	-4.2	---	54.0	---	---	---
2400.968	H/V	---	-3.1	---	54.0	---	---	---
2701.089	H/V	---	-2.1	---	54.0	---	---	---
3001.210	H/V	---	-1.2	---	54.0	---	---	---

Remark “—” means that the emission level is too low to be measured.

b. TX On

Operation Mode : Weak Light

Test Date : JUN. 06, 1998

Temperature : 23 °C

Humidity : 68%

Frequency (MHz)	Ant-Pol H/V	Meter Reading (dBuV)	Corrected Factor (dB)	Result @3m (dBuV/m)	Limit @3m (dBuV/m)	Margin (dB)	Table Degree (Deg.)	Ant. High (m)
300.121	H	44.7	-7.0	37.7	46.0	-8.3	180	1.70
601.060	V	32.6	-4.4	28.2	46.0	-17.8	180	1.50
899.800	V	32.0	2.1	34.1	46.0	-11.9	180	1.80
1200.484	H/V	---	-8.8	---	54.0	---	---	---
1500.605	H/V	---	-7.5	---	54.0	---	---	---
1800.726	H/V	---	-5.8	---	54.0	---	---	---
2100.847	H/V	---	-4.2	---	54.0	---	---	---
2400.968	H/V	---	-3.1	---	54.0	---	---	---
2701.089	H/V	---	-2.1	---	54.0	---	---	---
3001.210	H/V	---	-1.2	---	54.0	---	---	---

Remark “—” means that the emission level is too low to be measured.

3.4 Field Strength Calculation

The field strength is calculated by adding the Antenna Factor and Cable Factor, and subtracting the Amplifier Gain (if any) from the measured reading. The basic equation with a sample calculation is as follows:

$$\text{RESULT} = \text{READING} + \text{CORR. FACTOR}$$

where CORR. FACTOR = Antenna FACTOR + Cable FACTOR

Assume a receiver reading of 22.5 dB μ V is obtained. The Antenna Factor of 14.5 and a Cable Factor of 1.5 is added . The total of field strength is 38.5 dB μ V/m.

$$\text{RESULT} = 22.5 + 14.5 + 1.5 = 38.5 \text{ dB } \mu \text{ V/m}$$

$$\begin{aligned} \text{Level in } \mu \text{ V/m} &= \text{Common Antilogarithm}[(38.5 \text{ dB } \mu \text{ V/m})/20] \\ &= 84.14 \mu \text{ V/m} \end{aligned}$$

3.5 Radiated Emission Measuring Equipment

The following test equipment are used during the radiated test .

Equipment	Manufacturer	Model No.	Next Cal. Date
Spectrum Analyzer	Hewlett-Packard	8568B	10/16/1998
Pre-selector	Hewlett-Packard	85685A	10/16/1998
Quasi Peak Detector	Hewlett-Packard	85650A	10/07/1998
Spectrum Analyzer	Adventest	R3271	09/02/1998
RF Test Receiver	Rohde & Schwarz	ESVS 30	12/19/1998
Horn Antenna	EMCO	3115	08/05/1998
Log periodic Antenna	EMCO	3146	12/10/1999
Biconical Antenna	EMCO	3110	08/05/1998
Preamplifier	Hewlett-Packard	8449B	05/08/1999
Preamplifier	Hewlett-Packard	8447D	12/23/1998

4. CONDUCTED EMISSION MEASUREMENT

4.1 Standard Applicable

For unintentional and intentional device, Line Conducted Emission Limits are in accordance to § 15.107(a) and § 15.207(a) respectively. Both Limits are identical specification.

4.2 Measurement Procedure

1. Setup the configuration per figure 3.
2. A preliminary scan with a spectrum monitor is performed to identify the frequency of emission that has the highest amplitude relative to the limit by operating the EUT in selected modes of operation, typical cable positions, and with a typical system configuration.
3. Record the 6 or 8 highest emissions relative to the limit.
4. Measure each frequency obtained from step 3 by a test receiver set on quasi peak detector function, and then record the accuracy frequency and emission level. If all emissions measured in the specified band are attenuated more than 20 dB from the limit, this step would be ignored, and the peak detector function would be used.
5. Confirm the highest three emissions with variation of the EUT cable configuration and record the final data.
6. Repeat all above procedures on measuring each operation mode of EUT.

Figure 3 : Conducted emissions measurement configuration

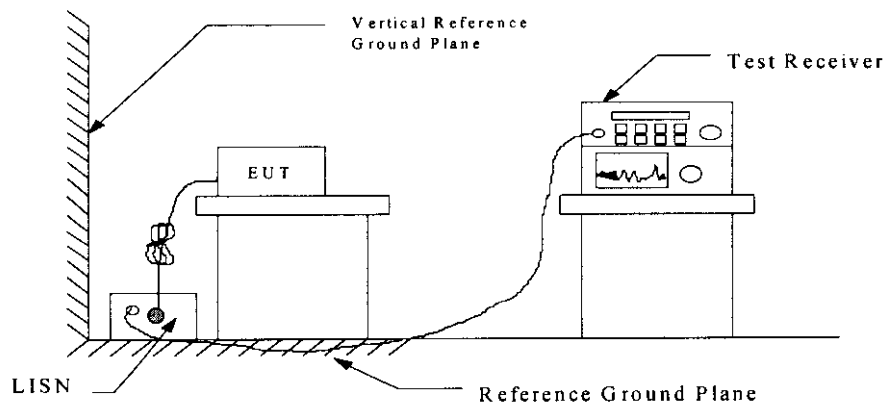

4.3 Conducted Emission Data**A.**

Operation Mode : Weak Light (Tx Off)

Test Date : JUN. 06, 1998

Temperature : 26 °C

Humidity: 50%

Frequency (MHz)	Reading (dBuV)		Factor (dB)	Result (dBuV)		Limit (dBuV)	Margin (dB)
	Va	Vb		Va	Vb		
0.450	33.1	36.6	0.2	33.3	36.8	48.0	-11.2
0.470	33.9	35.7	0.2	34.1	35.9	48.0	-12.1
0.500	30.2	32.1	0.2	30.4	32.3	48.0	-15.7
0.510	32.3	34.3	0.2	32.5	34.5	48.0	-13.5
5.000	24.9	27.1	0.3	25.2	27.4	48.0	-20.6
6.520	28.3	28.5	0.4	28.7	28.9	48.0	-19.1

B.

Operation Mode : Weak Light (Tx On)

Test Date : JUN. 06, 1998

Temperature : 26 °C

Humidity: 50%

Frequency (MHz)	Reading (dBuV)		Factor (dB)	Result (dBuV)		Limit (dBuV)	Margin (dB)
	Va	Vb		Va	Vb		
0.450	33.4	36.9	0.2	33.6	37.1	48.0	-10.9
0.470	34.1	35.9	0.2	34.3	36.1	48.0	-11.9
0.500	30.4	32.3	0.2	30.6	32.5	48.0	-15.5
0.510	32.6	34.6	0.2	32.8	34.8	48.0	-13.2
5.000	25.1	27.3	0.3	25.4	27.6	48.0	-20.4
6.520	28.5	28.7	0.4	28.9	29.1	48.0	-18.9
8.430	24.9	25.2	0.4	25.3	25.6	48.0	-22.4

dBuV

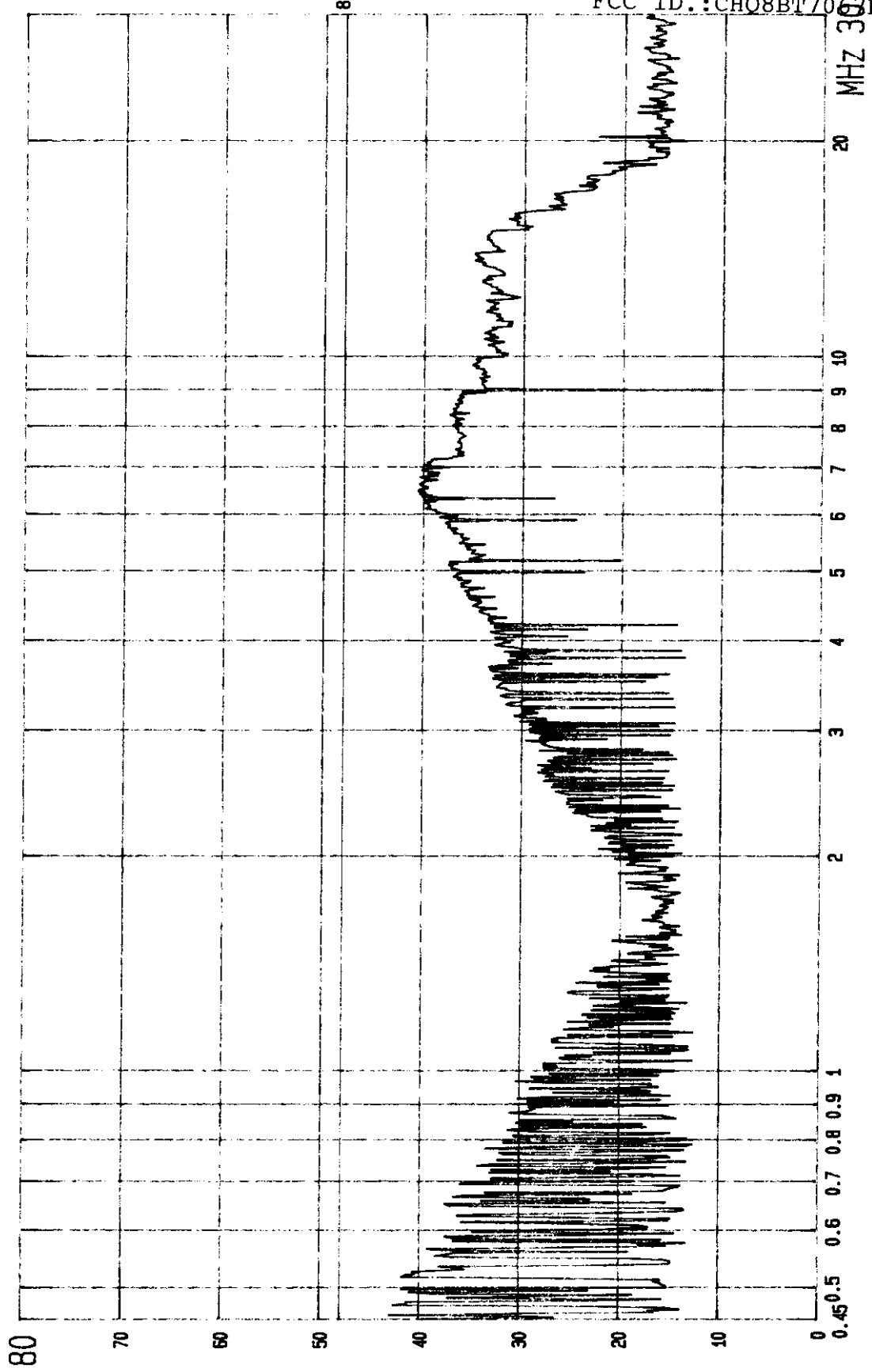

 FCC CONDUCTED TEST
 MODEL: 7067R
 EUT: RECEIVER
 MODE: WEAK LIGHT (TX OFF)
 LISN: Va
 8:QP
 CLASS B LIMIT
 ETC EMI LAB.

dBuV

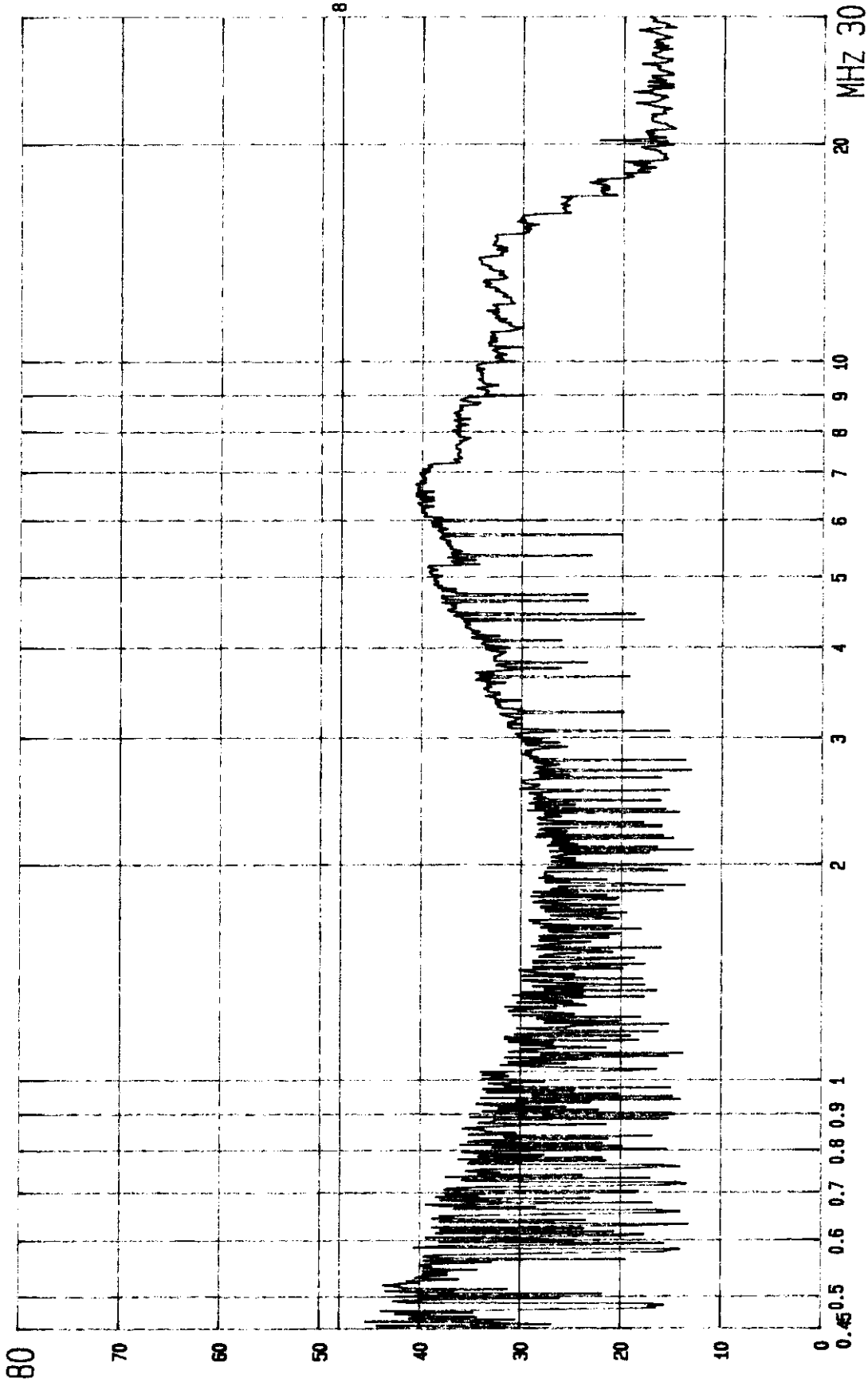

FCC CONDUCTED TEST
MODEL: 7067R

MODE: WEAK LIGHT (TX OFF)
EUT: RECEIVER

LISN: Vb
8: QP

CLASS B LIMIT
ETC EMI LAB.

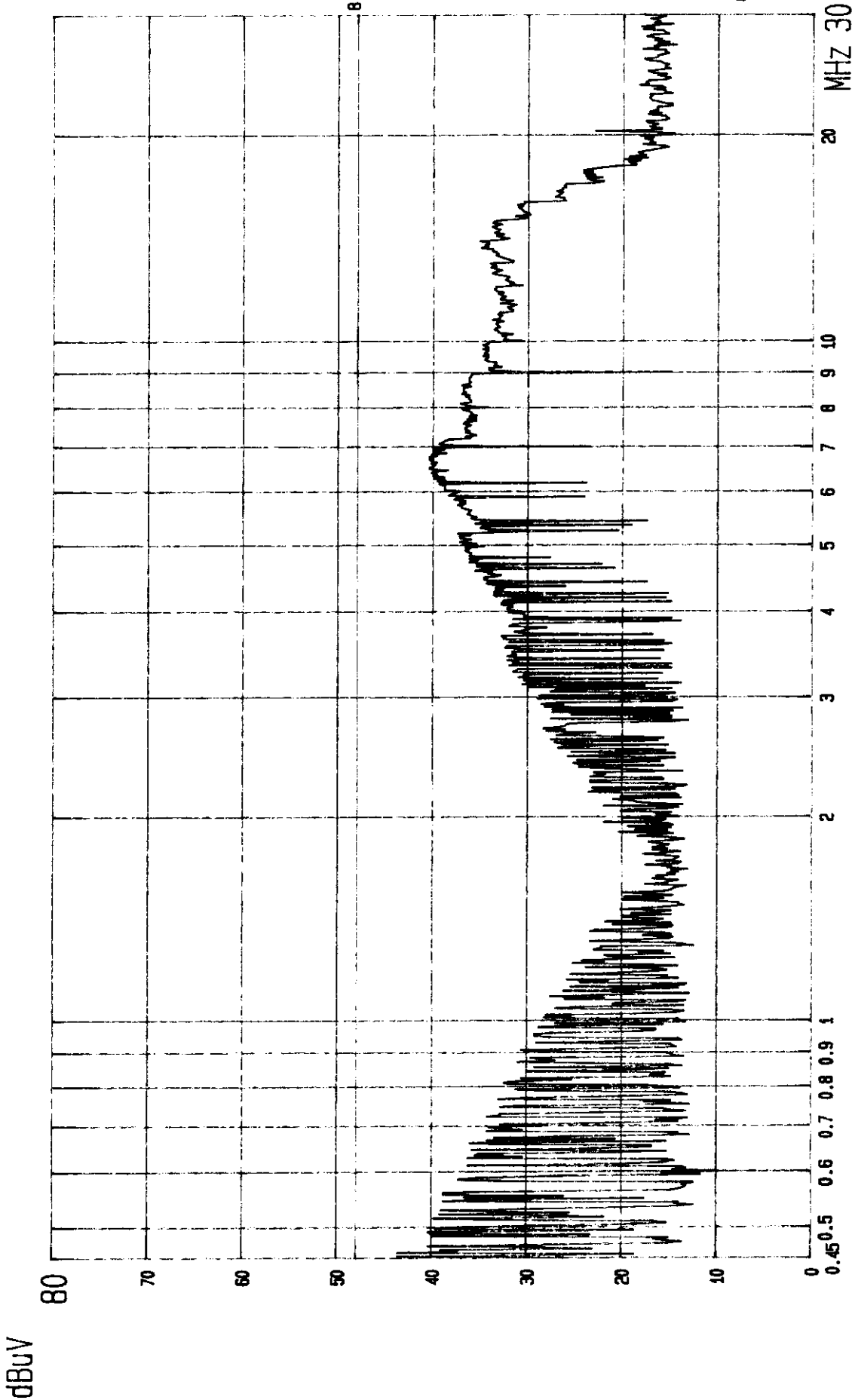

CLASS B LIMIT
ETC EMI LAB.

8:QP
LISN: Va

EUT: RECEIVER
MODE: WEAK LIGHT (TX ON)

FCC CONDUCTED TEST
MODEL: 7067R

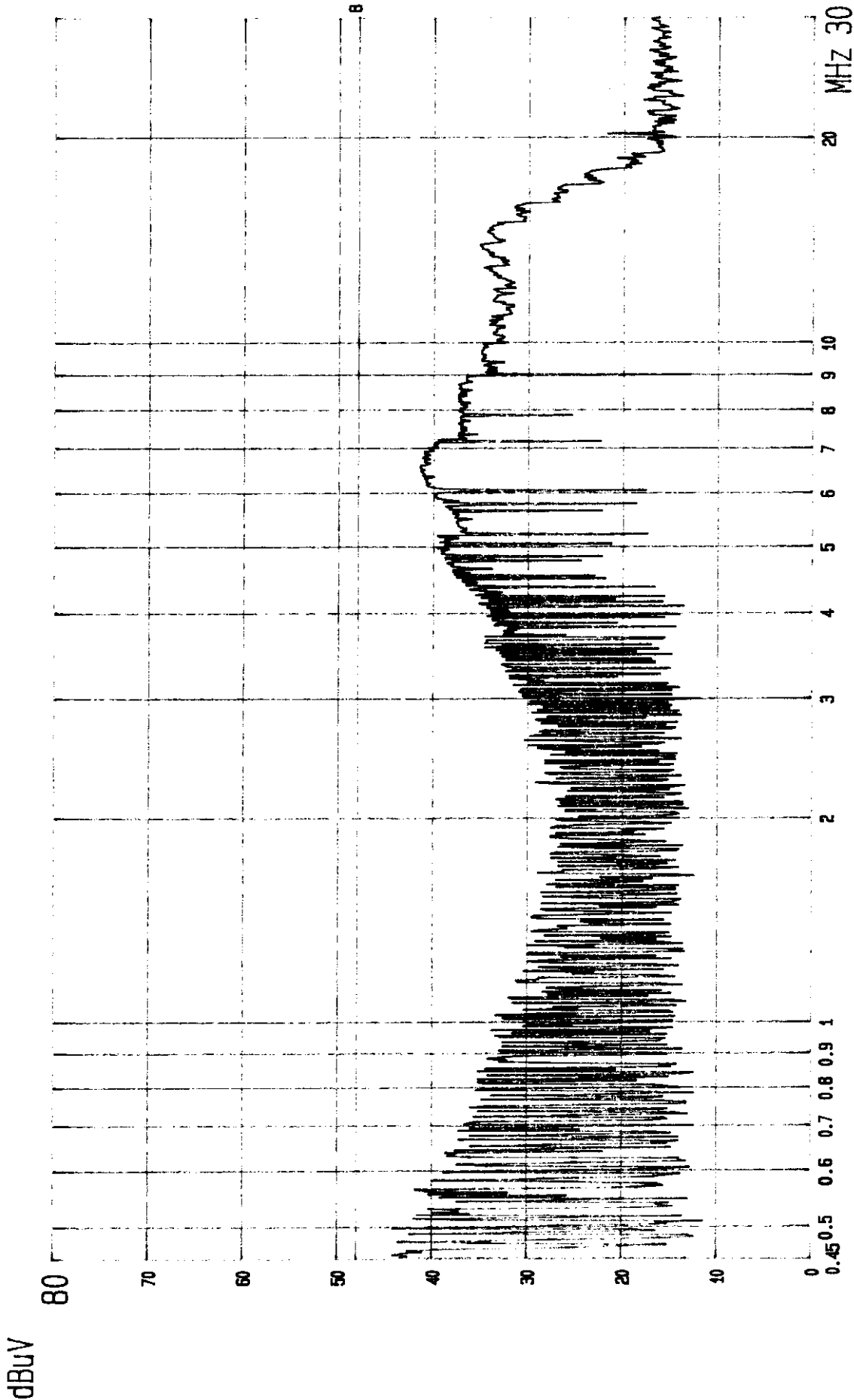

FCC CONDUCTED TEST
MODEL: 7067R
EUT: RECEIVER
MODE: WEAK LIGHT (TX ON)
LISN: Vb
8: QP
CLASS B LIMIT
ETC EMI LAB.

4.4 Result Data Calculation

The result data is calculated by adding the LISN Factor to the measured reading. The basic equation with a sample calculation is as follows:

$$\mathbf{RESULT = READING + LISN FACTOR}$$

Assume a receiver reading of 22.5 dB μ V is obtained, and LISN Factor is 0.1 dB, then the total of field strength is 22.6 dB μ V.

$$\text{RESULT} = 22.5 + 0.1 = 22.6 \text{ dB } \mu \text{ V}$$

$$\begin{aligned} \text{Level in } \mu \text{ V} &= \text{Common Antilogarithm}[(22.6 \text{ dB } \mu \text{ V})/20] \\ &= 13.48 \mu \text{ V} \end{aligned}$$

4.5 Conducted Emission Measuring Equipment

The following test equipment are used during the conducted test .

Equipment	Manufacturer	Model No.	Next Cal. Date
RF Test Receiver	Rohde and Schwarz	ESH3	01/04/1999
Spectrum Monitor	Rohde and Schwarz	EZM	N.C.R.
Line Impedance Stabilization network	Kyoritsu	KNW-407	12/01/1998
Plotter	Hewlett-Packard	7440A	N/A
Shielded Room	Riken	N/A	N.C.R.