

Nikon

No reproduction in any form of this manual, in whole or in part (except for brief quotation in critical articles or reviews), may be made without written authorization from NIKON CORPORATION.

Nikon

En

The Nikon Guide to Digital Photography
with the

COOLPIX P1 P2

DIGITAL CAMERA

COOLPIX P1/P2 (En)



NIKON CORPORATION
Fuji Bldg., 2-3 Marunouchi 3-chome,
Chiyoda-ku, Tokyo 100-8331, Japan

Printed in Japan
XXXXXXXXXXXXXX
XXXXXXXXXX--



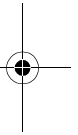
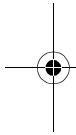
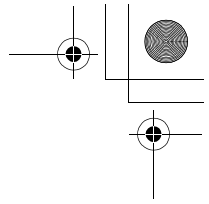
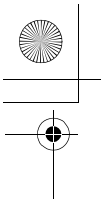

Trademark Information



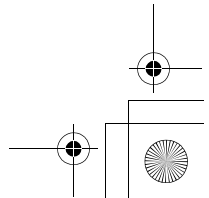
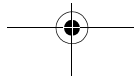
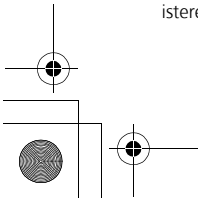

Apple, the Apple logo, Macintosh, Mac OS, and QuickTime are registered trademarks of Apple Computer, Inc. Finder is trademark of Apple Computer, Inc. Microsoft and Windows are registered trademarks of Microsoft Corporation. Internet is a trademark of Digital Equipment Corporation. Adobe and Acrobat are registered trademarks of Adobe Systems Inc. The SD logo is a trademark of the SD Card Association. PictBridge is a trademark. Face-priority AF technology is provided by Identix®. D-Lighting technology is provided by Apical Limited. All other trade names mentioned in this manual or the other documentation provided with your Nikon product are trademarks or registered trademarks of their respective holders.



Thank you for your purchase of a Nikon COOLPIX P1/P2 digital camera. This manual has been written to help you enjoy taking pictures with your Nikon digital camera. Read this manual thoroughly before use, and keep it handy when using the product.

Symbols Used in this Manual

To make it easier to find the information you need, the following symbols and conventions are used:

-  This icon marks cautions, information that should be read before use to prevent damage to your camera.
-  This icon marks notes, information that should be read before using your camera.
-  This icon marks tips, additional information that may be helpful when using your camera.
-  This icon indicates that more information is available elsewhere in this manual or in the *Quick Start Guide*.

Product Names Used in this Manual

In this manual, the COOLPIX P1 and COOLPIX P2 are sometimes referred to as P1 and P2, respectively.

Illustrations and on-screen text in this manual may differ from the actual display.

Before You Begin

First Steps

Basic Photography

More on Photography

More on Playback

Picture Editing

Movies

The Shooting Menu

The Playback Menu

The Set-up Menu

Wireless Transfer Mode

Technical Notes

For Your Safety

To prevent damage to your Nikon product or injury to yourself or to others, read the following safety precautions in their entirety before using this equipment. Keep these safety instructions where all those who use the product will read them.

The consequences that could result from failure to observe the precautions listed in this section are indicated by the following symbol:



This icon marks warnings, information that should be read before using this product to prevent possible injury.

WARNINGS



Turn off immediately in the event of malfunction

Should you notice smoke or an unusual smell coming from the camera, battery charger, or AC adapter (available separately), unplug the battery charger or AC adapter and remove the battery immediately, taking care to avoid burns. Continued operation could result in injury. After removing or disconnecting the power source, take the equipment to a Nikon-authorized service representative for inspection.



Do not use in the presence of flammable gas

Do not use electronic equipment in the presence of flammable gas, as this could result in explosion or fire.



Do not place strap around the neck of an infant or child

Placing the camera strap around the neck of an infant or child could result in strangulation.



Keep out of reach of children

Particular care should be taken to prevent infants from putting the batteries or other small parts into their mouths.



Do not disassemble

Touching the internal parts of the camera or battery charger could result in injury. Repairs should be performed only by qualified technicians. Should the camera or battery charger break open as the result of a fall or other accident, take the product to a Nikon-authorized service representative for inspection after unplugging the product and/or removing the battery.



Observe the following precautions when handling the battery charger

- Keep dry. Failure to observe this precaution could result in fire or electric shock.
- Dust on or near the metal parts of the plug should be removed with a dry cloth. Continued use could result in fire.
- Do not handle the power cable or go near the battery charger during thunderstorms. Failure to observe this precaution could result in electric shock.
- Do not damage, modify, forcibly tug or bend the power cable, place it under heavy objects, or expose it to heat or flame. Should the insulation be damaged and the wires become exposed, take it to a Nikon-authorized service representative for inspection. Failure to observe these precautions could result in fire or electric shock.

- Do not handle the plug or battery charger with wet hands. Failure to observe this precaution could result in electric shock.



Observe proper precautions when handling batteries

Batteries may leak or explode if improperly handled. Observe the following precautions when handling a battery for use in this product:

- Before replacing the battery, turn the product off and make sure the power-on lamp has gone out. If you are using an AC adapter, be sure it is unplugged.
- Before replacing the battery, turn the product off. If you are using an AC adapter, be sure it is unplugged.
- Use only rechargeable Nikon EN-EL8 lithium-ion batteries (supplied).
- When inserting the battery, do not attempt to insert it upside down or backwards.
- Do not short or disassemble batteries.
- Do not expose batteries to flame or to excessive heat.
- Do not immerse in or expose to water.
- Replace the terminal cover when transporting the battery. Do not transport or store with metal objects such as necklaces or hairpins.
- Batteries are prone to leakage when fully discharged. To avoid damage to the product, be sure to remove the battery when no charge remains.
- Immediately after use, or when the product is used on battery power for an extended period, the battery may become hot. Before removing the battery, turn the camera off and allow the battery to cool.
- Discontinue use immediately should you notice any change in the battery, such as discoloration or deformation.



Use appropriate cables, batteries, battery chargers, and AC adapters

Use only the cables, batteries, battery chargers, and AC adapters provided or sold by Nikon for the purpose, to maintain compliance with product regulations.



Removing memory cards

Memory cards may become hot during use. Observe due caution when removing memory cards from the camera.



Handle moving parts with care

Be careful that your fingers or other objects are not pinched by the lens or other moving parts.



CD-ROMs

The CD-ROMs on which the software and manuals are distributed should not be played back on audio CD equipment. Playing CD-ROMs on an audio CD player could cause hearing loss or damage the equipment.



Observe caution when operating the flash

Using the flash close to your subject's eyes could cause temporary visual impairment. Particular care should be observed if photographing infants, when the flash should be no less than one meter (39") from the subject.



Do not fire the unit while the flash head is touching a person or object

Such use can result in the person being burned, and/or their clothes igniting from the heat of the flash's firing.



Avoid contact with liquid crystal

Should the monitor break, care should be taken to avoid injury due to broken glass and to prevent liquid crystal from the monitor touching the skin or entering the eyes or mouth.



Keep dry

Do not immerse in or exposure to water. Continuing to use the product under such circumstances may cause fire or an electric shock.



Follow the instructions of hospital and airline personnel

This device emits radio frequency radiation that could interfere with medical or navigational equipment. Do not use this device in a hospital or on board an airplane without first obtaining the permission of hospital or airline staff.

Notices

- No part of the manuals included with this product may be reproduced, transmitted, transcribed, stored in a retrieval system, or translated into any language in any form, by any means, without Nikon's prior written permission.
- Nikon reserves the right to change the specifications of the hardware and software described in these manuals at any time and without prior notice.
- Nikon will not be held liable for any damages resulting from the use of this product.
- While every effort has been made to ensure that the information in these manuals is accurate and complete, we would appreciate it were you to bring any errors or omissions to the attention of the Nikon representative in your area (address provided separately).

Notice for customers in the U.S.A.

Federal Communications Commission (FCC)

Declaration of Conformity

This device complies with Part 15 of the FCC rules. Operation of the device is subject to the following two conditions: (1) this device may not cause harmful interference, and (2) this device must accept any interference received, including interference that may cause undesired operation.

Products that contain a radio transmitter are labeled with FCC ID and may also carry the FCC logo.

FCC Radio Frequency Interference Statement

This equipment has been tested and found to comply with the limits for a Class B digital device, pursuant to Part 15 of the FCC rules. These limits are designed to provide reasonable protection against harmful interference in a residential installation. This equipment generates, uses, and can radiate radio frequency energy and, if not installed and used in accordance with the instructions, may cause harmful interference to radio communications. However, there is no guarantee that interference will not occur in a particular installation. If this equipment does cause harmful interference to radio or television reception, which can be determined by turning the equipment off and on, the user is encouraged to try to correct the interference by one or more of the following measures:

- Reorient or relocate the receiving antenna.
- Increase the separation between the equipment and receiver.

- Connect the equipment into an outlet on a circuit different from that to which the receiver is connected.
- Consult the dealer or an experienced radio/television technician for help.

FCC Radiation Exposure Statement

The available scientific evidence does not show that any health problems are associated with using low power wireless devices. There is no proof, however, that these low power wireless devices are absolutely safe. Low power Wireless devices emit low levels of radio frequency energy (RF) in the microwave range while being used. Whereas high levels of RF can produce health effects (by heating tissue), exposure to low level RF that does not produce heating effects causes no known adverse health effects. Many studies of low level RF exposures have not found any biological effects. Some studies have suggested that some biological effects might occur, but such findings have not been confirmed by additional research. The NIKON COOLPIX P1/P2 has been tested and found to comply with the Federal Communications Commission (FCC) guidelines on radio frequency energy (RF) exposures. The maximum SAR levels tested for the NIKON COOLPIX P1/P2 has been shown to be 0.208 W/kg at Body.

This device should not be co-located or operated with any other antenna or transmitter.



CAUTIONS
Modifications

The FCC requires the user to be notified that any changes or modifications made to this device that are not expressly approved by Nikon Corporation may void the user's authority to operate the equipment.

Interface Cables

Use the interface cables sold or provided by Nikon for your equipment. Using other interface cables may exceed the limits of Class B Part 15 of the FCC rules.

Notice for customers in the State of California

WARNING: Handling the cord on this product will expose you to lead, a chemical known to the State of California to cause birth defects or other reproductive harm. **Wash hands after handling.**

Nikon Inc.,
1300 Walt Whitman Road, Melville, New York
11747-3064, U.S.A.
Tel.: 631-547-4200

Notice for customers in Canada

CAUTION

This class B digital apparatus meets all requirements of the Canadian Interference Causing Equipment Regulations.

ATTENTION

Cet appareil numérique de la classe B respecte toutes les exigences du Règlement sur le matériel brouilleur du Canada.

RSS-210 14. Exposure of Humans to RF Fields

The installer of this radio equipment must ensure that the antenna is located or pointed such that it does not emit RF field in excess of Health Canada limits for the general population; consult Safety Code 6, obtainable from Health Canada's website

www.hc-sc.gc.ca/rpb

Notice for customers in Europe

Hereby, Nikon, declares that this digital camera is in compliance with the essential requirements and other relevant provisions of Directive 1999/5/EC.

Notice Concerning Prohibition of Copying or Reproduction

Note that simply being in possession of material that has been digitally copied or reproduced by means of a scanner, digital camera or other device may be punishable by law.

- **Items prohibited by law from being copied or reproduced**
Do not copy or reproduce paper money, coins, securities, government bonds, or local government bonds, even if such copies or reproductions are stamped "Sample".

The copying or reproduction of paper money, coins, or securities which are circulated in a foreign country is prohibited.

Unless the prior permission of the government has been obtained, the copying or reproduction of unused postage stamps or post cards issued by the government is prohibited.

The copying or reproduction of stamps issued by the government and of certified documents stipulated by law is prohibited.
- **Cautions on certain copies and reproductions**
The government has issued cautions on copies or reproductions of securities issued by private companies (shares, bills, checks, gift certificates, etc.), commuter passes, or coupon tickets, except when a minimum of necessary copies are to be provided for business use by a company. Also, do not copy or reproduce passports issued by the government, licenses issued by public agencies and private groups, ID cards, and tickets, such as passes and meal coupons.
- **Comply with copyright notices**
The copying or reproduction of copyrighted creative works such as books, music, paintings, woodcut prints, maps, drawings, movies, and photographs is governed by national and international copyright laws. Do not use this product for the purpose of making illegal copies or to infringe copyright laws.

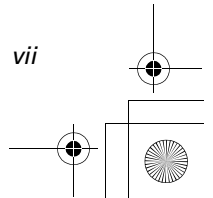
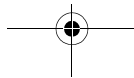
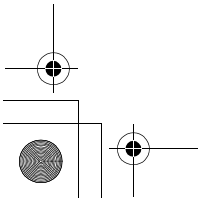
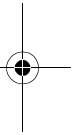
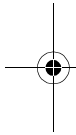
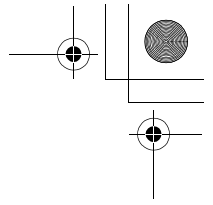
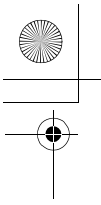

































Table of Contents

For Your Safety	ii
Notices	iv
Table of Contents	viii
Before You Begin	1
Introduction.....	1
Parts of the Camera.....	2
The Monitor.....	4
The Mode Dial	6
Navigating the Menus.....	7
Displaying the Help	7
First Steps.....	8
Charging the Battery.....	8
Inserting Batteries	10
Inserting Memory Cards.....	12
Checking the Battery Level.....	14
Basic Setup	16
Basic Photography.....	18
Step 1—Select  (auto) Mode.....	18
Step 2—Frame the Picture	20
Step 3—Focus and Shoot.....	22
Step 4—View the Results (Full-screen Playback)	24
More on Photography.....	26
⚡ When Lighting Is Poor: Using the Flash	27
🕒 Taking a Self-Portrait: Using the Self-Timer	30
👉 Focusing on the Subject: Using Focus Mode	31
☒ Controlling Exposure: Exposure Compensation	33
🎭 SCENE Scene Mode.....	34
Controlling Exposure: Exposure Modes	45
📄 Controlling File Size: Selecting Image Quality and Size	47
ISO Taking Pictures Using Sensitivity: Setting Sensitivity	50
WB Adjusting the Hue: Using White Balance.....	52
More on Playback.....	55
Viewing Pictures on the Camera	55
Voice Memos: Recording and Playback	58
Viewing Pictures on TV	60
Viewing Pictures on a Computer	61
Printing Pictures.....	65
🖨️ Print Set	66
Printing via Direct USB Connection.....	70

Picture Editing.....	76
Available Picture Editing	76
Cropping Pictures – Crop	77
Enhancing Contrast: D-Lighting	78
 Creating a Smaller Picture: Small Pic	79
Movies	80
 Recording Movies	80
Viewing Movies	85
The Shooting Menu	86
Using the Shooting Menu	86
 Metering	88
 Continuous	89
BSS Best Shot Selector	92
BKT Auto Bracketing	93
 Flash Exp. Comp	94
 Image Adjustment	94
 Image Sharpening	95
 Saturation Control	96
[+] AF Area Mode	97
 Auto-focus Mode	100
Fixed Aperture	100
NR Noise Reduction	101
 Reset	102
 User Setting	103
The Playback Menu	104
Using the Playback Menu	104
List by Date	107
 Slide Show	109
 Delete	111
 Protect	112
 Transfer Marking	112
 Hide Image	113
 Copy	114

The Set-up Menu	115
Using the Set-up Menu	115
 Menu	116
 Welcome Screen	117
 Date	118
 Monitor Settings	120
 Date Imprint	122
Shot Confirmation	124
 AF Assist	125
 Sound Settings	126
 Auto Off	127
 Format Memory/Card	128
 Language	129
 Interface (USB/Video mode)	129
 Auto Transfer	130
 Reset All	131
Ver. Firmware Version	132
Wireless Transfer Mode	133
Functions of the Wireless Transfer Mode	133
Using the Wireless Transfer Mode	134
Managing Profile Information	140
Transferring Images to a Computer	141
Technical Notes	150
Optional Accessories	150
Caring for Your Camera	152
Error Messages	155
Troubleshooting	161
Specifications	165
Index	168

Before You Begin

Introduction

Use Only Nikon Brand Electronic Accessories

Nikon COOLPIX cameras are designed to the highest standards and include complex electronic circuitry. Only Nikon brand electronic accessories (including battery chargers, batteries, AC adapters, and Speedlights) certified by Nikon specifically for use with this Nikon digital camera are engineered and proven to operate within the operational and safety requirements of this electronic circuitry.

THE USE OF NON-NIKON ELECTRONIC ACCESSORIES COULD DAMAGE THE CAMERA AND MAY VOID YOUR NIKON WARRANTY. The use of third-party rechargeable Li-ion batteries not approved by Nikon could interfere with normal operation of the camera or result in the batteries overheating, igniting, rupturing, or leaking.

For more information about Nikon brand accessories, contact a local authorized Nikon dealer.

Before Taking Important Pictures

Before taking pictures on important occasions (such as at weddings or before taking the camera with you on a trip), take a test shot to ensure that the camera is functioning normally. Nikon will not be held liable for damages or lost profits that may result from product malfunction.

Internal Memory and SD Memory Card

This camera uses both internal memory and an SD memory card for storing pictures. If you insert a memory card into the camera, pictures will automatically be stored on the card instead of in the internal memory. To store, view or delete pictures in the internal memory or to format the internal memory, remove the memory card first.

Life-Long Learning

As part of Nikon's "Life-Long Learning" commitment to ongoing product support and education, continually-updated information is available on-line at the following sites:

- For users in the U.S.A.: <http://www.nikonusa.com/>
- For users in Europe: <http://www.europe-nikon.com/support>
- For users in Asia, Oceania, the Middle East, and Africa: <http://www.nikon-asia.com/>

Visit these sites to keep up-to-date with the latest product information, tips, answers to frequently-asked questions (FAQs), and general advice on digital imaging and photography. Additional information may be available from the Nikon representative in your area. See the URL below for contact information:

<http://nikonimaging.com/>

Parts of the Camera

Before You Begin

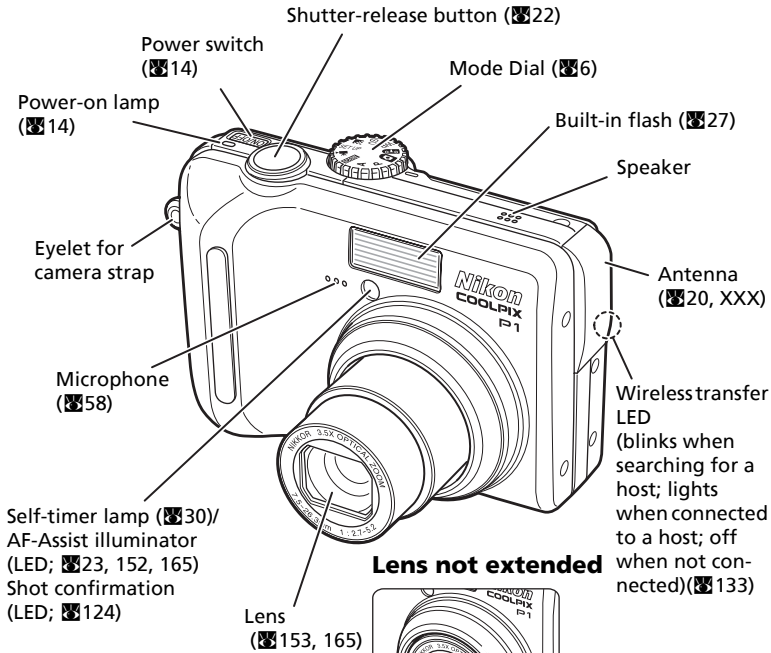

Attaching the Camera strap

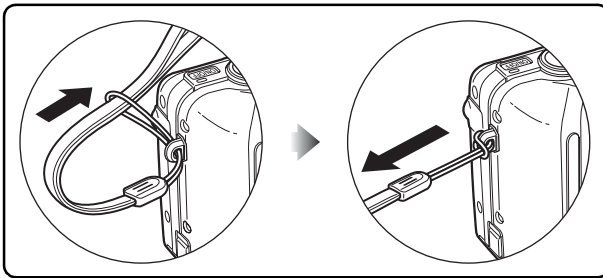

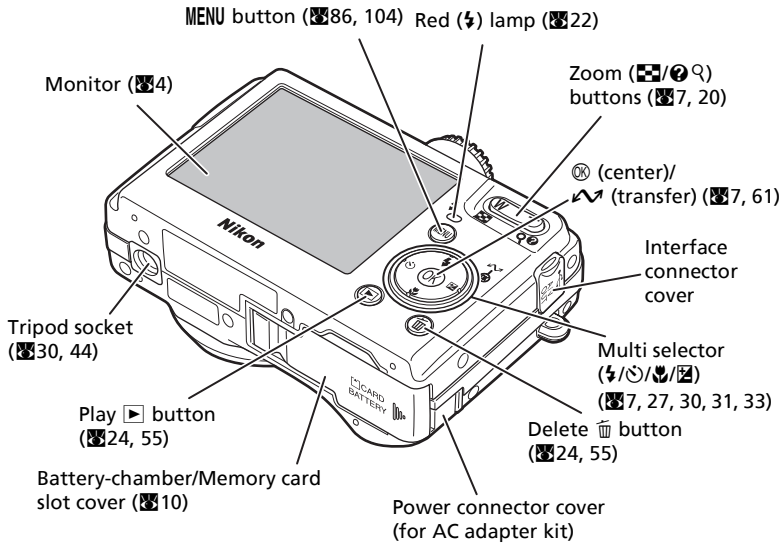

Before You Begin

USB (62)/
Audio/Video (A/V) out
(60) connector

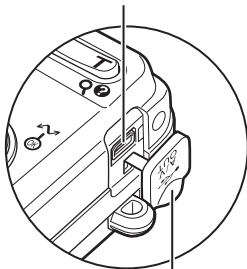

Battery-chamber/
Memory card slot
cover (10)

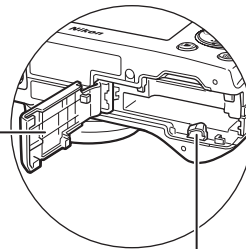

The Monitor

Before You Begin

Shooting

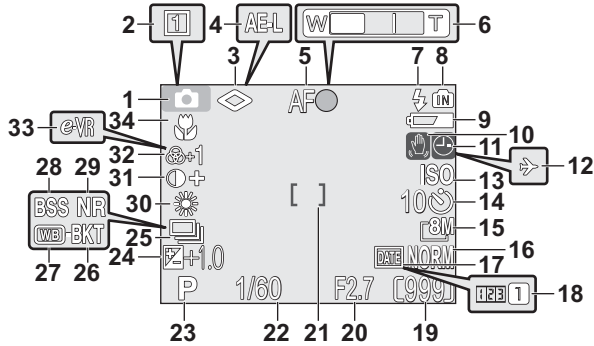

Icons displayed vary with camera settings.

<p>1 Shooting mode 18, 34, 81</p> <p>2 Custom No¹⁾ 103</p> <p>3 Image sharpening 95</p> <p>4 AE-L indicator²⁾ 43</p> <p>5 Focus indicator³⁾ 22</p> <p>6 Zoom indicator⁴⁾ 20</p> <p>7 Flash mode 27</p> <p>8 Internal memory/Memory card indicator 18</p> <p>9 Battery level indicator⁵⁾ 14</p> <p>10 Camera shake icon⁶⁾ 28, 155</p> <p>11 "Date not set" icon⁷⁾ 16</p> <p>12 Time zone indicator⁸⁾ 118</p> <p>13 Sensitivity (ISO equivalency) 50</p> <p>14 Self-timer indicator 30</p> <p>15 Image size 18, 47</p> <p>16 Image quality 18, 47</p> <p>17 Date imprint indicator 122</p> <p>18 Date counter/ Stored date number 123</p> <p>19 Number of exposures remaining/ Length of movie 18, 80</p> <p>20 Aperture 46</p> <p>21 Focus area⁹⁾ 22, 97</p> <p>22 Shutter speed 45</p> <p>23 Exposure mode 45</p>	<p>24 Exposure compensation 33</p> <p>25 Continuous shooting mode 89</p> <p>26 Bracketing¹⁰⁾ 93</p> <p>27 White balance bracketing¹¹⁾ 93</p> <p>28 Best Shot Selector (BSS) 92</p> <p>29 Noise reduction 101</p> <p>30 White balance 52</p> <p>31 Image adjustment 94</p> <p>32 Saturation control 96</p> <p>33 Electronic VR 84</p> <p>34 Focus mode 31</p>
--	--

1) Appears when mode dial is rotated to **P** or **A**.

2) Appears when taking a picture in Panorama assist mode.

3) Appears when the shutter-release button is pressed halfway.

4) Appears when the zoom buttons are pressed.

5) Appears when the battery is running low.

6) Blinks at slow shutter speeds to warn that pictures may be blurred.

7) Blinks when the camera clock has not been set.

8) Appears when the new city time zone has been set.

9) Displays the focus area when the shutter-release button is pressed halfway if **AF area mode** has been set to **[] Auto**.

10) Appears when **Auto bracketing** has been set to **BKT Auto bracketing**.

11) Appears when **WB (white balance) bracketing** has been set.

Playback

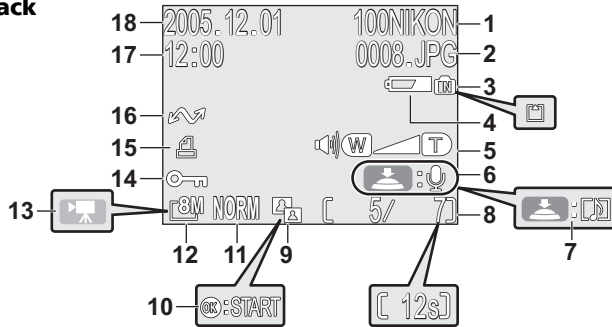

Icons displayed vary with camera settings.

1	Current folder	25	9	D-Lighting icon	78
2	File number and type	25	10	Movie playback icon	85
3	Internal memory/Memory card indicator	18	11	Image quality	18
4	Battery level indicator ¹⁾	14	12	Image size	18
5	Volume indicator	85	13	Movie indicator	80
6	Voice memo recording guide	58	14	Protect icon	111
7	Voice memo playback guide	58	15	Print-order icon	66
8	Current frame number/Total number of frames/Length of movie	24, 85	16	Transfer icon	112
			17	Time of recording	16
			18	Date of recording	16

1) Appears when the battery is running low.

Display in the Monitor

Use **Photo info** in **Monitor settings** of the Set-up menu to display or hide information for shooting or playback (120).

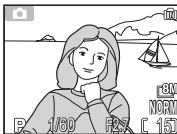

Monitor shows current settings and view through lens



Monitor shows view through lens only

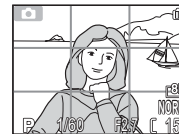

Framing grid

If the battery level indicator appears, the monitor will turn off temporarily while the flash is charging (14, 23).

The Mode Dial

Before You Begin

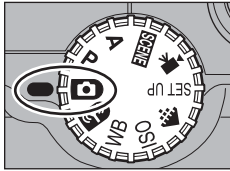

To select a mode, align the mode icon with the "●" mark next to the mode dial.

P A (45)

Choose these modes for varying degrees of control over shutter speed and aperture.

Auto (18)

A simple "point-and-shoot" mode recommended for first time users of digital cameras.

Wireless Transfer mode (133)

Connect the camera to a wireless LAN and transfer pictures to a computer or print images from a printer.

SCENE Scene (34)

Choose from 16 "scenes" suited to different subjects or shooting conditions and let the camera do the rest.

Movie (80)

Choose from seven movie modes.

SET UP Setup (115)

Display the Set-up menu, where you can perform such tasks as setting the camera clock and adjusting monitor brightness.

Image quality/Image size (47)

ISO ISO sensitivity (50)

WB White balance (52)

Display menus of each option.

Navigating the Menus

Use the multi selector to perform operations such as selecting or canceling menu items that appear in the monitor.

Press the **OK** button after selecting an item to perform that operation.

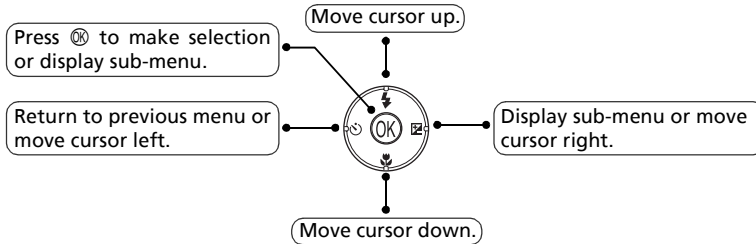

Before You Begin

Use the multi selector to perform operations such as moving the area in which a picture is displayed or selecting a picture.

Displaying the Help

The COOLPIX P1/P2 displays explanations about modes and menus of the camera in the monitor.

Pressing **?** (Help) button when displaying a menu displays the help for the selected scene or item.

Pressing **OK** while displaying the help performs the function.

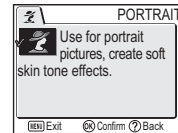

First Steps

Charging the Battery

The camera uses a rechargeable Nikon EN-EL8 lithium-ion battery (supplied). Charge the battery before first use or when the battery is running low.

First Steps

1 Connect the power cable

Connect the power cable to the supplied MH-62 battery charger (①) and insert the wall plug into a power outlet (②). The CHARGE lamp will light to show that the charger is on (③).

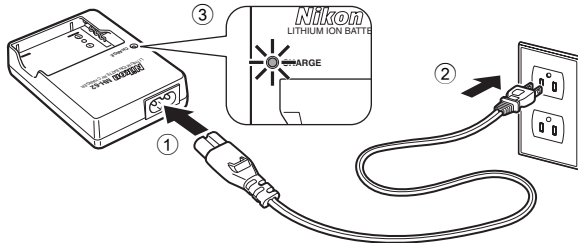

2 Charge the battery

Remove the terminal cover from EN-EL8 and insert the battery into the MH-62.

CHARGE lamp starts blinking when battery is inserted. Charging is complete when lamp stops blinking.

About two hours are required to charge a fully depleted battery.

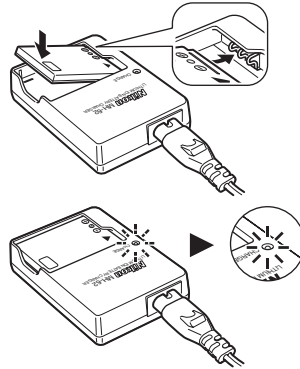

CHARGE lamp	Description
Blinks	Battery charging.
On	Battery fully charged.
Flickers	Battery error. If ambient temperature is not 0 to 40 °C (32 to 104 °F), wait until temperature is in this range before charging. Otherwise unplug charger and remove battery immediately and take both devices to retailer or Nikon-authorized service representative.

3 Unplug the charger

Remove the battery and unplug the charger.

First Steps

✓ The MH-62 Battery Charger

Before using the MH-62, read and follow the warnings and notices on pages ii to vi of this manual.

The MH-62 is for use with EN-EL8 batteries. Do not use with incompatible batteries. The supplied power cable is intended solely for use with the MH-62 and is for domestic use only. It may be necessary to purchase another cable for use abroad; consult with a local Nikon-authorized retailer or service representative.

✓ EN-EL8 Batteries

Before using the EN-EL8, read and follow the warnings and notices on pages ii–vi and 154 of this manual.

Do not use the battery at ambient temperatures below 0 °C (32 °F) or above 40 °C (104 °F). During charging, the temperature should be in the vicinity of 5 to 35 °C (41 to 95 °F). Note that the battery may become hot during use; wait for the battery to cool before charging. Failure to observe these precautions could damage the battery, impair its performance, or prevent it from charging normally.

✓ When the Battery Is Not in Use

When the battery is not in use, remove it from the camera or battery charger and replace the terminal cover. The camera and battery charger draw minute amounts of current even when off; if left in place, the battery could be drained to the point that it no longer functions.

Inserting Batteries

Insert an EN-EL8 battery that has been fully-charged using the supplied MH-62 battery charger into your camera.

First Steps

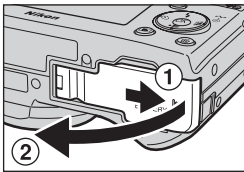

1 Open the battery-chamber/memory card slot cover

Slide the cover in the direction shown in (1) until it stops and open the cover (2).

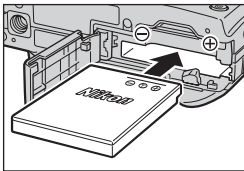

2 Insert the battery

Insert the battery as shown in the label at the entrance to the battery chamber, making sure the positive "+" and negative "-" terminals are in the correct orientation.

Inserting Batteries

Inserting the battery upside down or backwards could damage the camera. Check to be sure the battery is in the correct orientation.

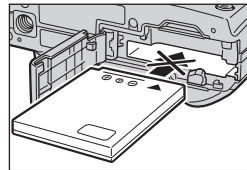

The orange battery latch is pushed aside as the battery is inserted. The latch will close when the battery is fully inserted.

Make sure that the battery latch is secured over the battery and that the battery is set.

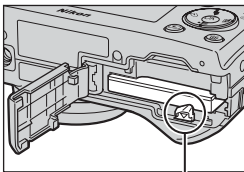
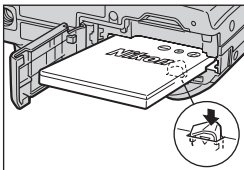

Battery Latch

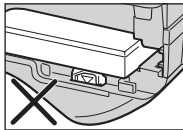
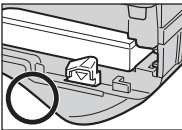

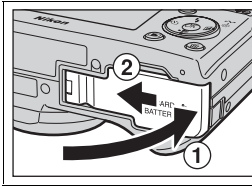

3 Close the battery-chamber/memory card slot cover

Close the cover (1) and slide it in until it latches (2).

Ensure the cover is closed firmly.

First Steps

✓ Replacing Batteries

Turn the camera off and make sure that the power-on lamp has gone out before opening the battery-chamber/memory card slot cover.

Slide the battery latch in the direction indicated to eject the battery, which can then be removed using your fingers.

- Note that the battery may become hot during use. Observe due caution when removing the battery.

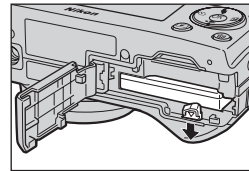

Alternative Power Sources

To power the camera continuously for extended periods, use an optional EH-62C AC adapter. **Do not, under any circumstances, use another make or model of AC adapter kit.** Failure to observe this precaution could result in overheating or in damage to the camera.

Inserting Memory Cards

Pictures can be stored in the camera's internal memory (about 32 MB for P1/16 MB for P2) or on a Secure Digital (SD) memory card. If no memory card has been inserted in the camera, pictures will be stored in the camera's internal memory, and if the camera contains a memory card, then pictures will automatically be stored on the card. To store pictures in the internal memory, remove the memory card.

First Steps

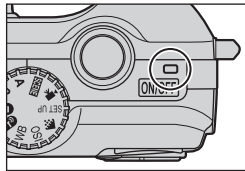

1 Confirm that the camera is off

The power-on lamp should be off.

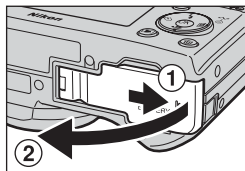

2 Open the battery-chamber/memory card slot cover

Slide the cover in the direction shown in (1) until it stops and open the cover (2).

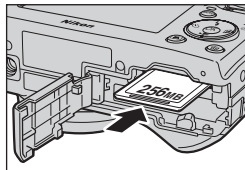

3 Insert the memory card

Insert the memory card in the direction of the arrow shown on the label at the entrance to the memory card slot until it stops.



Inserting Memory Cards

Insert the memory card terminals first. Inserting the card upside down or backwards could damage the camera or the card. Check to be sure the card is in the correct orientation.

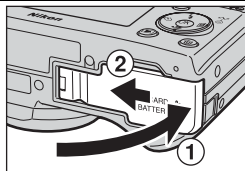
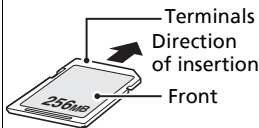
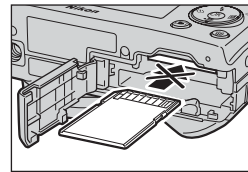

4 Close the battery-chamber/memory card slot cover

Close the cover (1) and slide it until it latches (2). Ensure the cover is closed firmly.

✓ The Write Protect Switch

Memory cards are equipped with a write protect switch to prevent accidental loss of data. When this switch is in the “lock” position, pictures cannot be recorded, deleted, or edited, and the card cannot be formatted. Do not lock the card when taking, editing, or deleting pictures, when transferring images to a computer, when using Wireless transfer mode, or when formatting the memory card.

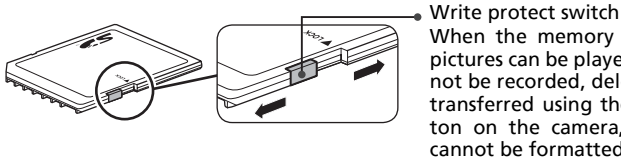

When the memory card is locked, pictures can be played back but cannot be recorded, deleted, edited, or transferred using the (M) button on the camera, and the card cannot be formatted.

First Steps

📎 Formatting Memory Cards

When using the memory cards formatted by the device other than COOLPIX P1/P2, format them using the COOLPIX P1/P2 before first use. For information on formatting memory cards, see “(M) Format Memory/Card” (128) in the Set-up menu.

📎 Removing Memory Cards

Memory cards can be removed without loss of data when the camera is off. To remove memory cards, turn the camera off and confirm that the power-on lamp is off. **Do not open the battery-chamber/memory card slot cover while the power-on lamp is lit.** Open the battery-chamber/memory card slot cover and press the memory card to partially eject the card. The card can then be removed by hand.

- Memory cards may become hot during use; observe due caution when removing memory cards.

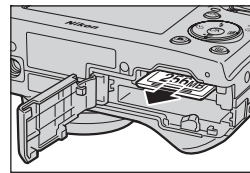
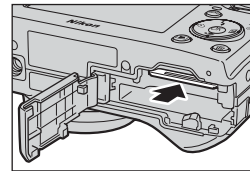

📎 Memory Cards

- Use only Secure Digital (SD) memory cards.
- Do not disassemble or modify.
- Do not drop, bend, or expose to water or strong physical shocks.
- Do not touch the metal terminals with your fingers or metal objects.
- Do not affix labels or stickers to the memory card.
- Do not leave in direct sunlight in a closed vehicle or in other areas exposed to high temperatures.
- Do not expose to high levels of humidity or to corrosive gas.

Checking the Battery Level

First Steps

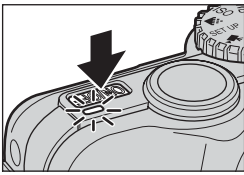

1 Turn the camera on

- Press the power switch.
- The power-on lamp lights when the camera is on.

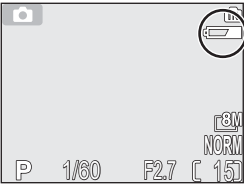

2 Check the battery level in the monitor

When the camera is turned on for the first time, a language-selection dialog will be displayed. Choose the desired language and press \odot . See "Basic Setup" (16).

Battery Level

Display	Meaning
NO ICON	Battery fully charged.
 (lights)	Low battery. If flash fires, monitor turns off while flash recharges.
WARNING!! BATTERY EXHAUSTED	Battery exhausted. Replace with fully charged battery.

The red ⚡ lamp and power-on lamp will blink when the "WARNING!! BATTERY EXHAUSTED" warning is displayed (155).

✓ Turning the Camera Off

To turn the camera off when the power-on lamp is lit, press the power switch.

- Do not remove the battery or disconnect the EH-62C AC adapter kit (optional) until the power-on lamp has gone out.

🔍 The ▶ Button

The camera can also be turned on by pressing the ▶ button for about one second (except in Wireless transfer mode). The monitor will show full-screen playback (📺24).

🔍 The Power-On Lamp

The power-on lamp indicates the following:

When the power-on lamp is	The camera is
On	On
Blinking	In Standby mode; Auto power off, or waiting for next shot in Interval timer shooting or Time-lapse movie
Off	Off

🔍 Auto Power Off (Standby Mode)

If no operations are performed for one minute (default setting), the monitor will turn off automatically and the camera will enter Standby mode to reduce the drain on the battery. While the camera is in Standby mode, the power-on lamp will blink. If no operations are performed for three minutes after the camera enters Standby mode, the power will turn off automatically and the power-on lamp will go out. The camera will be reactivated from Standby mode when you:

- Press the power switch
- Press the shutter-release button halfway
- Press the ▶ button (when not in Wireless transfer mode, camera is in Playback mode)
- Press the MENU button to display the menu for the current mode

The length of time before the camera enters Standby mode can be changed using the **Auto off** option in the Set-up menu (📺127).

However, the length of time is fixed in the following cases:

- When a menu is displayed: 3 minutes
- When pictures are being played back in a slide show: 30 minutes
- When in Wireless transfer mode: 3 minutes (**Auto off** is unavailable.)
- When using the optional EH-62C AC adapter kit: 30 minutes

When connecting the camera to a computer or printer with a USB cable, Auto power off function does not work.

Basic Setup

The first time the camera is turned on, a language-selection dialog will be displayed in the monitor. Follow the steps below to choose a language and set the time and date.

First Steps

- 1**

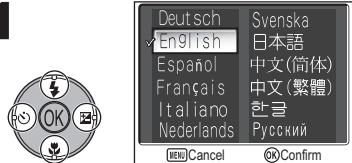

Highlight **Deutsch** (German), **English**, **Español** (Spanish), **Français** (French), **Italiano** (Italian), **Nederlands** (Dutch), **Svenska** (Swedish), **日本語** (Japanese), **中文(简体)** (Simplified Chinese), **中文(繁體)** (Traditional Chinese), **한글** (Korean), or **Русский** (Russian) and press **OK**.
- 2**

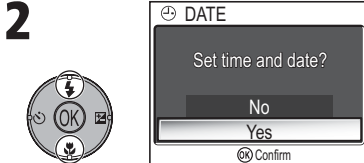

Confirmation dialog displayed. Highlight **Yes**.
- 3**

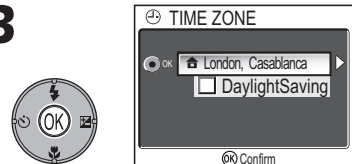

TIME ZONE menu displayed.*

* To turn daylight saving time on or off, press multi selector down to highlight **DaylightSaving** and press **OK**. When **DaylightSaving** is checked, time will automatically be advanced one hour (119). To return to Step 3, press multi selector up to highlight current time zone.
- 4**



Display map of world time zones.
- 5**

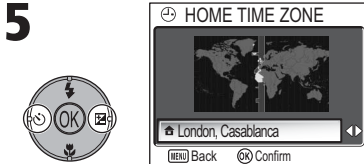

Select home time zone.

Date not Set

If you exit without setting time and date, the  ("date not set") icon will flash in the monitor (114) when the camera is in Shooting mode and all pictures will have time stamp of "0000.00.00 00:00" (still images) or "2005.01.01 00:00" (movies).

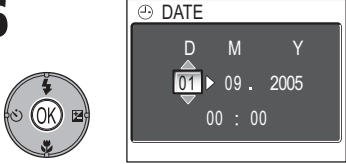
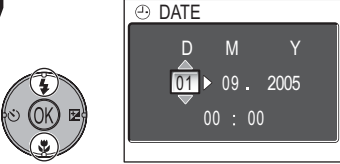
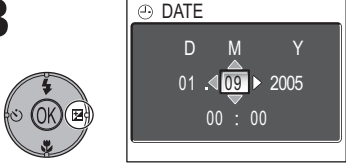
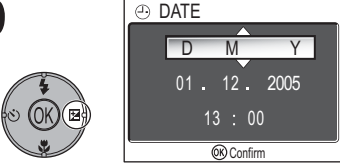
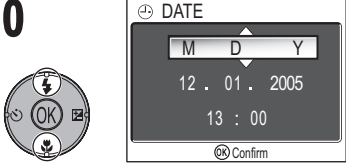
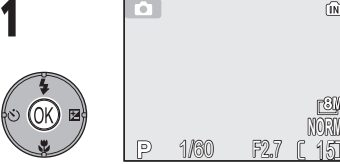
<p>6</p>  <p>Display DATE menu.</p>	<p>7</p>  <p>Edit Day (order of Day, Month, and Year may differ in some areas).</p>
<p>8</p>  <p>Select Month. Repeat steps 7 and 8 to edit Month, Year, hour, and minute.</p>	<p>9</p>  <p>Highlight D M Y.</p>
<p>10</p>  <p>Choose order in which Day, Month, and Year will be displayed.</p>	<p>11</p>  <p>Exit to mode currently selected with the mode dial. Note that time and date of recording will not be imprinted on pictures unless Date or Date and time is selected for Date imprint (122).</p>

 **The Clock Battery**

When the main battery is installed or the camera is powered by an EH-62C AC adapter (optional), the clock battery will charge in about ten hours. When fully charged, the clock battery can provide a few days of back-up power.

 **Setting the Clock from PictureProject (Windows XP/Mac OS X Only)**

If the camera is connected with the **USB** option set to **PTP** (161) in the **Interface** menu of the Set-up menu, PictureProject and Wireless Camera Setup Utility (both provided) can be used to set the camera clock to the same time and date as the computer. See the *PictureProject Reference Manual* (on CD) for details.

Basic Photography

Step 1-Select Mode

This section details the basic steps involved in taking pictures in  (Auto shooting mode). In this automatic, “point-and-shoot” mode, the majority of camera settings are controlled by the camera in response to shooting conditions, producing optimal results in most situations.

Basic Photography

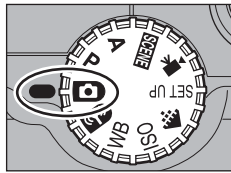

1 Rotate the mode dial to

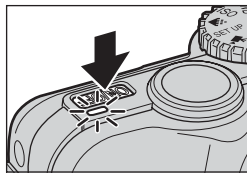

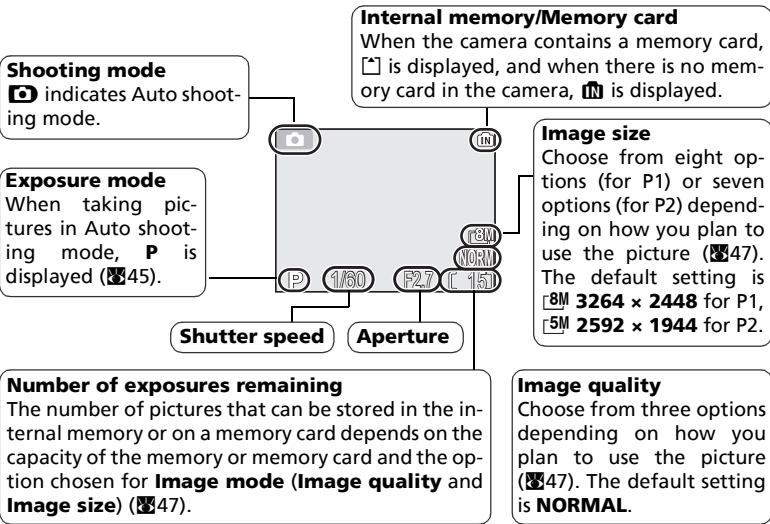

2 Turn the camera on

The power-on lamp will light and the monitor will display a welcome screen (see 117). The camera is ready to shoot when the monitor shows the view through the camera lens.





Number of Exposures Remaining

If the number of exposures remaining is zero, the message "OUT OF MEMORY" will be displayed in the monitor and no further pictures can be taken until you:

- Choose a lower image quality or image size setting ()47) (depending on certain conditions, no further pictures may be taken even if you change the setting).
- Insert a new memory card ()12).
- Remove the memory card so that pictures will be recorded in the internal memory (pictures can be taken only when the internal memory has space).
- Delete some pictures in the internal memory or on a memory card ()111).

Available Functions in Auto Shooting Mode

In  (Auto shooting) mode, the Flash, Self-timer, Focus, and Exposure compensation can be set ()26). In  mode, **Image quality** and **Image size** can be set.

Step 2—Frame the Picture

Basic Photography

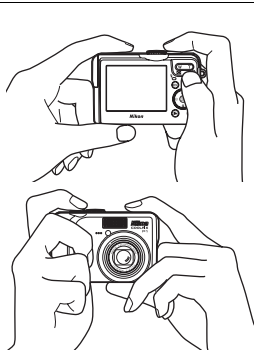

1 Ready the camera

Hold the camera steadily in both hands. Photographs can be framed in the monitor.

Don't Block the Shot

To avoid dark or partially obscured pictures, keep your fingers and other objects away from the lens, flash window, AF-assist illuminator, microphone, and antenna.





Zoom out



Zoom in

2 Frame your subject

Your Nikon digital camera is equipped with two types of built-in zoom: optical zoom, in which the camera's telescoping lens can be used to magnify the subject up to 3.5 ×, and digital zoom, in which digital processing is used to further magnify the image up to 4 ×, for a total of 14 ×. Use the zoom buttons to frame your subject in the center of the monitor:

- Press the  (**W**) button to zoom out from your subject, increasing the area visible in the frame.
- Press the  (**T**) button to zoom in on your subject so that it fills a larger area of the frame.







Indicator in monitor shows amount of zoom when either button is pressed



Digital zoom

To use digital zoom

When the camera is zoomed in to maximum magnification, holding the  (**T**) button down for more than two seconds will trigger digital zoom. The zoom indicator will turn yellow. Use the  (**T**) and  (**W**) buttons to adjust zoom in the digital zoom range. To cancel digital zoom, press  (**W**) until the zoom indicator turns white.

✓ Digital Zoom

- In digital zoom, data from the camera's image sensor is processed digitally, enlarging the center area of the picture to fill the frame. Unlike optical zoom, digital zoom does not increase the amount of detail visible in the picture. Instead, details visible at maximum optical zoom are simply enlarged, producing a slightly "grainy" image.
- When digital zoom is working, the focus area is fixed in the center of the frame (ⓧ97).
- When digital zoom is working, **Metering** is set just like  **Center-weighted** (ⓧ88).

📎 When Lighting Is Poor

When lighting is poor, sensitivity is raised to compensate and the image in the monitor may be slightly mottled. This is normal and does not indicate a malfunction.

Step 3—Focus and Shoot

Basic Photography

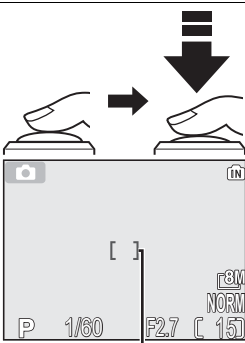

Focus area

Red (⚡) Lamp

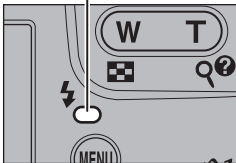

Focus indicator

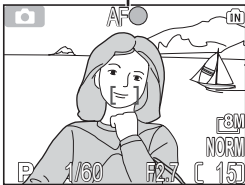

1 Focus

Press the shutter-release button halfway to set focus and exposure.

The camera has a two stage shutter-release button. The camera sets focus and exposure when the button is pressed halfway. Focus and exposure will remain locked while the shutter-release button is kept in this position.

- In **AF** mode, the camera focuses with Auto-focus on subject at center of frame.
- When subject is in focus, the selected Focus area turns green.

With the shutter-release button pressed halfway, check the focus indicator and Red (⚡) lamp:

Focus indicator	On (green)	Subject in focus.
	Blinks red	Camera unable to focus on subject at center of frame. Using focus lock, focus on another subject at same distance, then recompose picture and shoot.
Red (⚡) lamp	On (red)	Flash will fire when picture is taken.
	Blinks red	Flash is charging.
	Off	Flash is off or not required.

2 Take the picture

- Press the shutter-release button the rest of the way down to take the picture.
- To prevent blur, press the shutter-release button down smoothly.

 **During Recording**

While pictures are being recorded to the memory or memory card, the memory icon (⏏) or (M) will blink. **Do not turn the camera off, eject the memory card, or remove or disconnect the power source while pictures are being recorded.** Cutting power or removing the memory card in these circumstances could result in loss of data or in damage to the camera, internal memory, or card.

 **Low Battery**

If the flash fires when the low battery icon is displayed, the monitor will turn off while the flash recharges.

 **Getting Good Results with Autofocus**

Autofocus performs best when there is contrast between the subject and the background and the subject is evenly lit. It does not perform well if the subject is very dark or moving rapidly, if there are objects of sharply differing brightness in the scene (e.g., the sun is behind your subject and their features are in deep shadow), or if there are several objects at different distances from the camera at the center of the frame (e.g., your subject is inside a cage).

 **Autofocus**

The COOLPIX P1/P2 has two modes that allow control of the Autofocus; **AF area mode** (97) and **Auto-focus mode** (100).

 **AF-Assist Illuminator**

COOLPIX P1/P2 is equipped with an AF-assist illuminator. If lighting is poor, the built-in AF-assist illuminator will light when the shutter-release button is pressed halfway, allowing the camera to focus even when the subject is poorly lit. For more information on AF-assist illuminator, see “ AF Assist” in the Set-up menu (125).

Step 4-View the Results (Full-screen Playback)

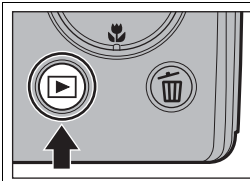

1 Press the  button

Basic Photography

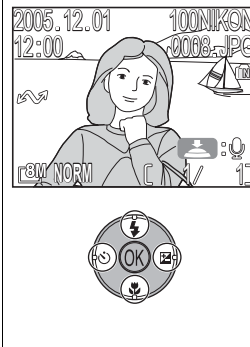



2 View pictures in the monitor

- This mode is called "Full-screen playback."
- To view additional pictures, press multi selector down or right to view pictures in the order recorded, up or left to view pictures in reverse order.
- Pictures are displayed briefly at low resolution while being read from the memory or a memory card. This makes it possible to scroll rapidly through the pictures in the memory or a memory card without waiting for each image to be displayed at full resolution.

To cancel Full-screen playback and return to the Auto shooting mode, press the  button again.

Deleting Unwanted Pictures

During Shooting mode or Playback mode, pressing  displays the delete confirmation dialog (except when a menu is displayed). Highlight **Yes** and press  to delete the currently displayed picture and return to Shooting mode or Playback mode.

- Highlight **No** and press  to return to Shooting screen or Playback screen without deleting the picture.

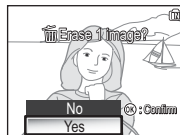

The Button

Pressing the  button for about one second will turn the camera on (**Auto off** is unavailable.). Press again to return to the mode selected with the mode dial.

More About Playback









For more information on playback, see "More on Playback" (P.55 - 75).

Image File and Folder Names



In the memory or on the memory card, pictures are identified by file names with three parts: a four letter identifier, a four-digit file number assigned automatically by the camera in ascending order, and a three-letter extension (e.g., "DSCN0001.JPG"). When a picture is viewed in the monitor, the file number and extension appear in the top right corner of the display. The identifier is not displayed, but is visible when images are transferred to a computer.

	Picture type	Identifier	Extension	
Original	Still picture	DSCN	.JPG	24
	Movie	DSCN	.MOV	85
	Time-lapse movie	INTN	.MOV	83
Copy	Copy created using Small pic.	SSCN	.JPG	79
	Cropped copy	RSCN	.JPG	77
	Copy created using D-Lighting	FSCN	.JPG	78
Audio file	Voice memo	DSCN, RSCN, SSCN, FSCN	.WAV	58









Basic Photography

- Pictures are stored in a folder created automatically by the camera. The folder name includes a three-digit folder number (e.g., 100NIKON).
- Folders can hold up to 200 pictures; if a picture is taken when the current folder contains 200 pictures, a new folder will be created by adding one to the largest folder number (e.g., 100NIKON → 101NIKON).
- When taking pictures using  **Panorama assist** (43),  **Ultra HS** (89), or  **Intvl timer shooting** (91), each sequence of pictures is stored in a folder with a name consisting of a three-digit folder number followed by "XXXX_xxx", "XXXN_xxx", or "XXXINTVL" (e.g., "101P_001", "101N_001" or "101INTVL").
- If you take a picture when the current folder contains a picture numbered 9999, a new folder will be created and file numbering will begin again from 0001.
- If file number reaches 200 or picture number reaches 9999 when the memory or the memory card contains a folder numbered 999, no further pictures can be taken, even if there is still memory capacity. Replace the memory card, or transfer all pictures to a computer (61) and then format the memory or the memory card (128).

More on Photography

In addition to  (Auto shooting) mode explained in “Basic Photography” (, 18), the COOLPIX P1/P2 has other shooting modes which are **P** (Programmed auto) mode, **A** (Aperture-priority auto) mode, and **SCENE** (Scene) mode. Use the mode dial to select the mode.

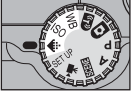
Some functions can be set when taking pictures with all the modes and some functions can only be set in **P** and **A** modes.





How to select	Function		P	A	SCENE	
	 Flash	○	○	○	○*1	27
	 Self timer					30
	 Focus mode					31
	 Exposure comp.					33
	 Image mode (image quality and image size)	○	○*2	○*2	○	47
	Sensitivity	-				50
	WB White balance	-				52
	Functions for Shooting menu	-	○	○	-*3	86





*1 The functions that can be set depend on the scene mode in use (, 34). See Scene mode for more information.

*2 Can be set from Shooting menu in **P** (Programmed auto) mode and **A** (Aperture-priority auto) mode (, 86).

*3 Pressing **MENU** in **SCENE** (Scene) mode displays the Scene menu (, 34).

When the Focus Area Selection Guide or Exposure Compensation Setting Screen is Displayed







When the Focus area selection guide (, 97) is displayed, Flash mode (, 27), Self-timer mode (, 30), Focus mode (, 31), and Exposure compensation (, 33) cannot be set.

When the Exposure compensation setting screen (, 33, 45) is displayed, Flash mode (, 27), Self-timer mode (, 30), and Focus mode (, 31) cannot be set.

Press  to hide Focus area selection guide or Exposure compensation setting screen and select mode.

⚡ When Lighting Is Poor: Using the Flash

The following six flash modes are available:

Mode	How it works	When to use it
 Auto	Flash fires when lighting is poor.	Best choice in most situations.
 Auto with red-eye reduction	Pre-flash is used before the main flash fires to reduce "red-eye." If "red-eye" is detected after an image is taken, the camera will correct "red-eye" when storing the picture.	Use for portraits (works best when subject is well within range of flash and looking at pre-flash). Not recommended when quick shutter response is required.
 Flash Cancel (off)	Flash will not fire even when lighting is poor.	Use to capture natural lighting under dim light or where use of flash is prohibited. If  (camera shake) icon appears, care should be taken to avoid blurring.
 Anytime Flash (fill flash)	Flash fires whenever picture is taken.	Use to "fill-in" (illuminate) shadows and back-lit subjects.
 Slow sync	Auto flash combined with slow shutter speeds.	Use to capture both subject and background at night or under dim light. Care should be taken to avoid blurring.
 Rear-curtain sync	Shutter speed slows; built-in flash fires just before shutter closes.	Creates stream of light trailing moving objects. Care should be taken to avoid blurring when lighting is poor.

More on Photography

To choose the flash mode:

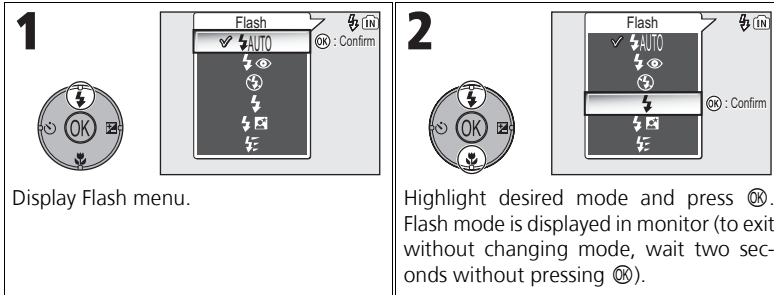

More on Photography

The (Camera Shake) Icon

When lighting is poor and the Flash is off () , shutter speeds will slow and pictures may be blurred. If the shutter speed required for exposure is very slow, the (camera shake) icon will appear in the monitor as a warning. Use of a tripod or support is recommended.

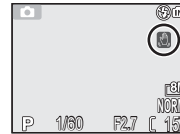

Using the Built-In Flash

Light from the flash reflected from particles of dust or other matter in the air may appear in pictures as bright specks. If this occurs, turn the flash off or zoom in and try again.

Flash Mode Selection

Flash mode is not available in the following cases:

- When taking pictures using **Continuous H**, **Continuous L**, **Ultra HS**, or **5 shot buffer** (89)
- **BSS** is set to **On** (92).
- **Auto bracketing** is set to **BKT Auto bracketing** (93).
- Taking a picture in some scene modes (34 - 44).
- Taking a picture when Focus mode is set to (Infinity mode) (31).
- Recording a movie other than Time-lapse movie (81).

Red-Eye Reduction

The "Red-eye reduction" flash function of the COOLPIX P1/P2 uses an advanced red-eye reduction method. Several pre-flashes are fired before the main flash fires to reduce "red-eye." In addition to this function, if "red-eye" is detected the camera will automatically correct it when storing the picture ("In-Camera Red-Eye Fix"). Using this function there is slight delay before you can press the shutter release again for the next shot. Depending on the situation, red-eye reduction may not always produce the desired results. In some rare cases, other picture areas may be affected as well as the "red-eye" area. In this case, choose another flash mode and try again.

Flash Range

- Flash range varies with zoom position. When the camera is zoomed all the way out, the flash has a range of approximately. XXX - XXX m/XXX' - XXX". When the camera is zoomed all the way in, the flash has a range of approximately. XXX - XXX m/XXX' - XXX" with **Auto** in **Sensitivity**.
- The flash may not be able to light the entire subject at distances of less than XXX cm (XXX'). When taking close-ups, play each picture back after shooting to check the results.

Sensitivity (ISO Equivalency)

Sensitivity is a measure of how sensitive the camera responds to light. Your Nikon digital camera normally has a sensitivity roughly equivalent to film with an ISO 50 rating for COOLPIX P1 or ISO 64 rating for COOLPIX P2.

When sensitivity is set to **Auto**, the camera will automatically increase sensitivity in response to lighting conditions, permitting faster exposures and minimizing blur caused by inadvertent camera movement (camera shake).

An **ISO** icon will be displayed to warn that pictures may be slightly mottled.

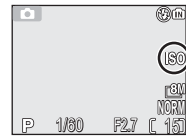



More on Photography

Taking a Self-Portrait: Using the Self-Timer

When the self-timer is on, pictures are taken 10 or 3 seconds after the shutter-release button is pressed. This can be used to allow you to appear in your own pictures or to prevent close-up or low-light shots from being blurred by the camera movement that occurs when the shutter-release button is pressed.

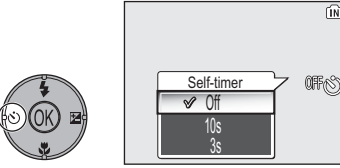
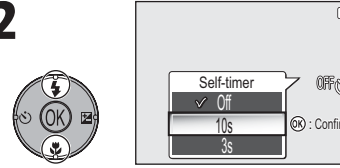
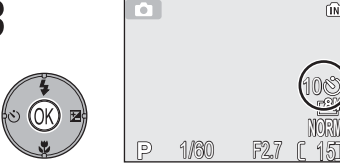

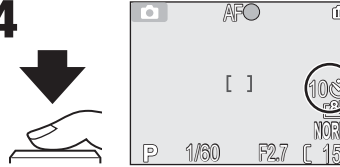

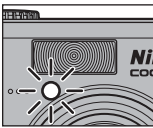
More on Photography

<p>1</p>  <p>Display Self-timer menu.</p>	<p>2</p>  <p>Highlight option.</p>
<p>3</p>  <p>Exit menu.  icon is displayed in monitor (to exit without setting the self-timer, wait two seconds without pressing ).</p>	<p>4</p>  <p>Start timer.</p> <ul style="list-style-type: none"> Countdown timer in monitor shows number of seconds remaining until shutter is released. Press the shutter-release button again to stop the self-timer.







The self-timer lamp on the front of the camera will blink until one second before the picture is taken, staying lit during the final second to warn that the shutter is about to be released.

The Self-Timer





- When using the self-timer, mount the camera on a tripod (recommended) or rest it on a flat, level surface.
- If an option other than  **Intvl timer shooting** is selected for **Continuous** (89), **Continuous** will automatically be set to  **Single**.
- When **BBS** is set to **ON** or **Auto bracketing** is set to **BKT Auto bracketing**, **Continuous** will automatically be set to  **Single**.

Focusing on the Subject: Using Focus Mode

Choose a focus mode according to the subject and composition.

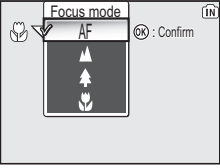
Mode	How it works	When to use it	Mode dial
NO ICON Autofocus	Camera automatically adjusts focus according to distance to subject.	Use when subject is 50 cm (1'8") or more from lens.	 More on Photography
 Infinity	Camera focuses at infinity; focus indicator lights whenever shutter-release button is pressed halfway. Flash is disabled.	Use when shooting distant scenes through foreground objects such as windows.	
2 m - ∞ (6'7" - infinity) ####	Camera can focus on subjects 2 m or more from the lens.	Use when subject is 2 m (6'7") or more from the lens. Camera focuses on subjects faster than with normal Autofocus.	
 Macro close-up	If zoomed in or out until  icon in the shooting display turns green, camera can focus on objects as close as 4 cm (1.6") to the lens.	Use for close-ups.	

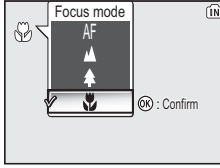
To choose the focus mode:

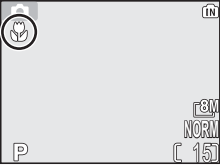
<p>1</p>  <p>Display Focus mode menu.</p>		<p>2</p>  <p>Highlight option.</p>	
<p>3</p>  <p>Exit menu. Focus mode icon appears in monitor (to exit without setting Focus mode, wait two seconds without pressing OK).</p>			

More on Photography

Focus Mode

Focus mode is not available in some scene modes (34 - 44).

Controlling Exposure: Exposure Compensation

Exposure compensation is used to alter the exposure from the value suggested by the camera. Exposure compensation can be set to values between -2.0 EV (underexposure) and $+2.0$ EV (overexposure) in increments of $1/3$ EV.

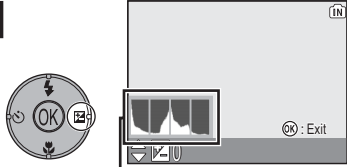
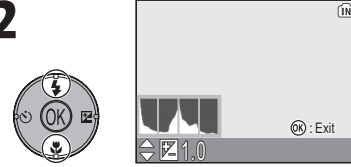
<p>1</p>  <p style="text-align: center;">Histogram</p> <p>Display value for exposure compensation (exposure compensation setting screen) and histogram (distribution of tones).</p>	<p>2</p>  <p>Highlight desired value.</p> <ul style="list-style-type: none"> • You can frame your subject, focus, and shoot. • Press OK to exit.
--	---

More on Photography

Exposure Compensation

Exposure compensation is not available when **FIREWORKS SHOW** (39) is selected in the Scene mode.

Exposure Compensation in P and A Modes

In addition to exposure compensation, exposure can be set with flexible program in **P** (Programmed auto) mode and aperture in **A** (Aperture-priority auto) mode.

Choosing a Value for Exposure Compensation

As a rule of thumb, select *positive* values when large areas of the frame are very brightly lit (for example, when photographing an expanse of sunlit water, sand, or snow) or when the background is much brighter than the main subject. Choose *negative* values when large areas of the frame are very dark (for example, when photographing a forest of dark green leaves) or when the background is much darker than the main subject. This is because the camera, in order to avoid extreme under- or over-exposure, tends to lower exposure when the frame is very bright and raise exposure when the frame is very dark. This can make naturally bright subjects look darker and naturally dark subjects appear over-bright, or “washed out.”

Histogram

A histogram shows distribution of tones in image; horizontal axis corresponds to pixel brightness, with dark tones to left and bright tones to right, while vertical axis shows number of pixels of each brightness in the image.

The scale of an axis is determined by the maximum number of pixels of a picture.







SCENE Scene Mode

Scene mode offers a menu of 16 “scenes”, each corresponding to a common situation, such as a backlit subject, sunset, or interior shot. Camera settings are automatically adjusted to suit the selected scene, sparing the user the necessity of adjusting each setting separately.

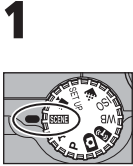
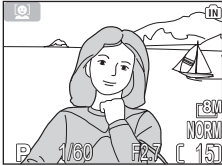
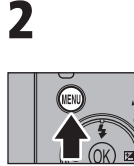
With Advanced option, 3 effects, including **NORMAL**, can be selected for 11 of the 16 scenes. For example, you can adjust an image in Portrait mode so that skin tones appear brighter.

To choose a scene:

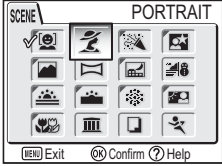
More on Photography

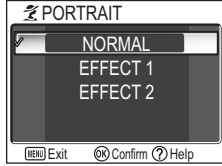
1	 	2	 
	Select Scene mode (default is  .		Display Scene menu.
3	 	4	 
	Highlight scene. <ul style="list-style-type: none"> To exit without changing current selection, press MENU. 		Display Advanced options menu. <ul style="list-style-type: none"> If there are no options, selected scene mode is set and screen returns to Shooting mode. Selected scene shown by icon in top left corner of the monitor.

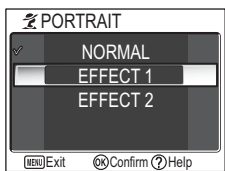
<p>5</p>  <p>Highlight option.</p>	<p>6</p>  <p>Set option and return to shooting mode.</p> <ul style="list-style-type: none">• If Advanced option is not set to NORMAL, the selected effect (1 or 2) appears next to the scene mode icon.
--	--











More on Photography

Scene Modes

Depending on your subject, scene modes may not always produce the desired results. If results are not to your satisfaction, choose  (Auto shooting), **P** or **A** and try again.

AF-assist Illuminator

AF-assist illuminator will not light in  **LANDSCAPE**,  **NIGHT LANDSCAPE**,  **DUSK/DAWN**,  **FIREWORKS SHOW**,  **MUSEUM**, or  **SPORTS** modes, or when the center focus area is not selected in  **PORTRAIT**,  **NIGHT PORTRAIT**, or  **CLOSE UP**.

Checking Advanced Options Effects

You may not be able to check Advanced options effects in the monitor. Play back the picture and check effects.

The following scenes are available:

 **PORTRAIT (FACE AF)**

This function is optimal for photographing portraits (from the waist up) of up to three people. When the camera recognizes human faces, the square focus area is displayed and the subject is in focus (Face-priority AF). When the shutter-release button is pressed halfway, focus area is locked and the camera focuses. Main subjects stand out clearly while background details are softened, lending sense of depth to composition.

See P.42 for more information on how to take pictures with this function.

For **EFFECT 1**, skin appears brighter, causing people to stand out.

For **EFFECT 2**, the surface of people's skin appears smoother.



(Changeable)



Autofocus

 **PORTRAIT**

Use for portraits. Main subject stands out clearly while background details are softened, lending composition sense of depth.

For **EFFECT 1**, skin appears brighter, causing people to stand out.

For **EFFECT 2**, the surface of people's skin appears smoother.

- Degree of softening depends on amount of light available.
- Select from 99 areas to focus on in the focus area using the multi selector.





(changeable)



Autofocus

More on Photography

 **Settings for Scene Modes**

 and  indicate Flash and Focus mode respectively.

 **The  (Camera Shake) Icon**

When the  icon appears in the monitor, pictures may be blurred. In this section, the precautions that you can take to avoid blur are indicated by stars:

- ★ hold the camera in both hands and brace elbows against your body.
- ★ ★ use a tripod or rest the camera on a flat, level surface.

 **PARTY/INDOOR**

Use for shots that include details of the background, or to capture the effects of candlelight and other indoor background lighting.

For **EFFECT 1**, pictures do not have as much noise and are blurred less than with normal shooting. Shutter response is also quicker than normal.

For **EFFECT 2**, pictures do not have as much noise and are blurred less, as with **EFFECT 1**. However, backgrounds appear brighter than when using **EFFECT 1**.

- Blur level: ★



(changeable)



Autofocus

 **NIGHT PORTRAIT**

Use for shots that provide natural balance between main subject and background when shooting portraits under low light.

For **EFFECT 1**, the brightness of the background is preserved, causing the subject to stand out.

For **EFFECT 2**, point sources of light radiate out in addition to the effects for **EFFECT 1**. This causes the nightscape to stand out.

- Noise reduction turns on automatically at slow shutter speeds. It takes more time than usual to store the picture.
- Select from 99 areas to focus on in the focus area using the multi selector.
- Blur level: ★ ★



(changeable)



Autofocus

 **LANDSCAPE**

Use for vivid landscape shots that enhance outlines, colors, and contrast in such subjects as skies and forests.

For **EFFECT 1**, colors are enhanced, causing landscape to appear more vivid and clear.

For **EFFECT 2**, the blue color of the sky is captured more vividly.

- Camera focuses at infinity. Focus indicator lights whenever shutter-release button is pressed halfway.
- AF-assist illuminator will not light even when lighting is poor.



More on Photography

 **PANORAMA ASSIST**

Use when taking a series of pictures that will later be joined to form a single scene (for example, a panorama or 360° virtual-reality image).



See P.43 for more information on how to take pictures with this function.

- Flash, Self-timer, Focus, and Exposure modes are fixed at settings for the first shot in a series. Zoom is also fixed at the adjustment for the first shot in a series.



 (changeable)



Autofocus
(changeable)

 **NIGHT LANDSCAPE**

A slow shutter speed is used to produce stunning night landscapes.



For **EFFECT 1**, pictures do not have as much noise as with normal shooting. Use of a tripod is recommended.

For **EFFECT 2**, point sources of light radiate out in addition to the effects for **EFFECT 1**. This causes the nightscapes to stand out. Use of a tripod is recommended.

- Focus is fixed at infinity. Focus indicator lights whenever shutter-release button is pressed halfway.
- Noise reduction turns on automatically at slow shutter speeds. It takes more time than usual to store the picture.
- AF-assist illuminator does not light even if for a dark subject.
- Blur level: ★ ★



 **BEACH/SNOW**

Vividly captures the brightness of such subjects as snowfields, beaches, or sunlit expanses of water.



 AUTO
(changeable)



Autofocus

More on Photography

SUNSET

Beautifully captures the deep hues in sunsets and sunrises. For **EFFECT 1**, the red hues are captured more vividly. For **EFFECT 2**, the colors of the sunset and sunrise are preserved.

- Blur level: ★



Autofocus

DUSK/DAWN

Beautifully captures the colors in the weak natural light before sunrise or after sunset.

For **EFFECT 1**, blue colors are captured more vividly. For **EFFECT 2**, the colors of the landscape are preserved.

- Camera focuses at infinity. Focus indicator lights whenever shutter-release button is pressed halfway.
- Noise reduction turns on automatically at slow shutter speeds. It takes more time than usual to store the picture.
- AF-assist illuminator does not light even if for a dark subject.
- Blur level: ★



More on Photography

FIREWORKS SHOW

The contrast with the background is deepened and fireworks stand out.

For **EFFECT 1**, pictures are shot with a slower shutter speed. Pictures may contain more noise than normal.

For **EFFECT 2**, large fireworks that burst slowly are clearly captured along with their trail.

- Focus is fixed at infinity. Focus indicator lights whenever shutter-release button is pressed halfway.
- Exposure compensation cannot be used.
- AF-assist illuminator does not light even if for a dark subject.
- Blur level: ★ ★



 **BACK LIGHT**

Use when light is coming from behind your subject, throwing their features into shadow, or when your subject is in the shade but the background is brightly lit.

For **EFFECT 1**, people appear brighter than normal.

For **EFFECT 2**, the picture is shot to match the brightness of people. Use this effect when people still appear dark using **EFFECT 1**.



Autofocus

 **CLOSE UP**

Use to capture vivid colors in close-up shots of flowers, insects, and other small objects, with the background artistically blurred.

For **EFFECT 1**, subject is captured more vividly and clearly.

For **EFFECT 2**, background details are softened and shutter response is quicker. Optimal for capturing moving subjects such as flowers swaying in the breeze.

- To focus on objects as close as 4 cm (1.6") to the lens, adjust zoom until the macro close-up icon () in monitor turns green.
- Minimum focus distance varies with zoom position.
- The camera focuses continuously, until AF lock is set by pressing the shutter-release button halfway.
- Select from 99 areas to focus on in the focus area using the multi selector.
- Blur level: ★

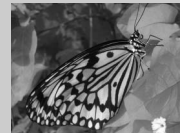

(changeable)



 **MUSEUM**

Use indoors where flash photography is prohibited (for example, in museums and art galleries) or in other indoor settings where you do not want to use the flash.

- The Best Shot Selector (BSS; ) turns on automatically, reducing the effects of inadvertent camera movement.
- Photography may be prohibited altogether in some locations. Be sure to obtain permission first.
- AF-assist illuminator does not light even if for a dark subject.
- Blur level: ★



Autofocus
(changeable)



More on Photography

COPY

Provides clear pictures of text or drawings on a white board or in printed matter such as a business card.

- Colored text and drawings may not show up well in the final picture.



  (changeable)

 **Autofocus**
(changeable)

SPORTS

Fast shutter speeds freeze motion for dynamic sports shots.

- Camera focuses continuously on center of frame until shutter-release button is pressed halfway to lock focus.
- While shutter-release button is fully pressed, camera shoots at about XXX frames per second; monitor turns off.
- Focus, exposure, and auto white balance are determined by first shot in each series.







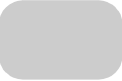





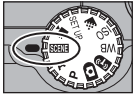

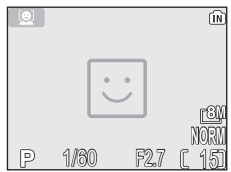
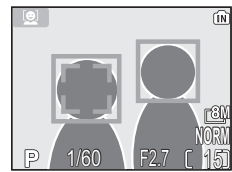

  (changeable)

 **Autofocus**
(changeable)

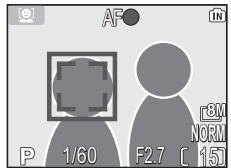

More on Photography

To use  **PORTRAIT (FACE AF)**:







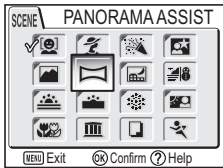

<p>1</p>  <p>Rotate the mode dial to SCENE.  blinks in the center of the monitor (default setting).</p> <ul style="list-style-type: none"> •  indicates the size of a subject's face that the camera can recognize. • If a different Scene menu is selected, press MENU button and select . 	 <p>2</p>  <p>When the subject's face becomes almost the same size as , the camera recognizes it and is framed with  (yellow).</p> <ul style="list-style-type: none"> • When the camera recognizes more than one face, the closest and largest is framed with  (yellow) and the others with  (yellow). The camera can recognize up to three faces. • If the frame ( or ) disappears because the subject moves, the camera goes back to the screen in step 1.
<p>3</p> 	 <p>Press the shutter-release button halfway to lock the focus on the face framed with  (yellow). When focus is locked, the color changes from yellow to green. Press the shutter-release button the rest of the way down to take the picture.</p>

More on Photography

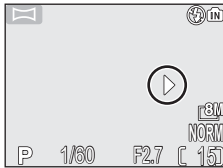
PORTRAIT (FACE AF) - Face-priority AF

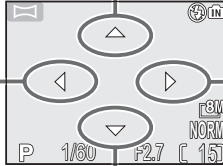
- The camera focuses continuously, until the camera recognizes a subject's face.
- When the camera does not recognize a face, the object at the center of the frame is focused.
- Optical zoom is available in the PORTRAIT (FACE AF) mode, but digital zoom (20) does not work.
- The face selected for focusing by the camera varies depending upon a number of conditions including the direction in which each person is facing.
- The camera is unable to recognize human faces in the following situations:
 - The subject is wearing sunglasses or part of face is obstructed in some other way.
 - The subject is facing sideways.
 - A portion of the face is too big because the subject is too close to the camera.
 - A portion of the face is too small because the subject is too far away from the camera.

To use  **PANORAMA ASSIST**:

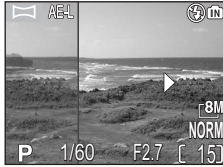
<p>1</p>   <p>Select  (PANORAMA ASSIST) in Scene menu.</p>	<p>2</p>   <p>Pan direction () displayed in yellow.</p>
<p>3</p>   <p>Bottom to top Right to left Left to right Top to bottom</p> <p>Select how pictures will be joined together in completed panorama. This is the direction in which to pan the camera after each shot.</p>	
<p>4</p>   <p>Make selection (to change selected pan direction, press  again and repeat steps 3 and 4). Pan direction displayed in white.</p>	<p>5</p>   <p>Take first picture. AE-L icon is displayed, and white balance and exposure compensation are locked. About one third of picture is shown superimposed on view through lens (if pan direction is left to right, picture will appear on left side of monitor).</p>



More on Photography

6



Compose the next shot to overlap with the previous picture.

7



Take next shot. Repeat steps 6 and 7 until all shots in series have been taken.

8



End series.

- Shooting will also end if changing mode using the mode dial or entering Standby mode.

More on Photography

Panorama Assist

The pan direction, Flash mode, Self-timer mode, Focus mode, and Exposure compensation cannot be changed after the first picture is taken. To change the pan direction, press the **MENU** button to end shooting and repeat steps 1 to 3.

Full-Screen Playback

When you press the  button after starting shooting, Panorama assist mode is terminated and the most recent picture will be displayed in the monitor.

Using a Tripod

Using a tripod makes it easier to compose overlapping shots.

Joining Panorama Pictures

Transfer the pictures taken with  **PANORAMA ASSIST** to your computer ( 61) and use the Panorama Maker function in PictureProject to join them into a single scene. For further information, see the *PictureProject Reference Manual* (on CD).

Controlling Exposure: Exposure Modes

In **P** and **A** modes, shutter speed and aperture can be adjusted to suit the user's creative intent.

P and **A** modes also give the user control over sensitivity (ISO equivalency; 50), white balance (52), and the options in the Shooting menu (86).

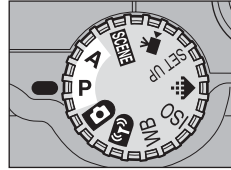

Mode	How it works	When to use it
P Programmed auto	Camera sets shutter speed and aperture for optimal exposure. "Flexible program" can be used to select additional combinations of shutter speed and aperture that will produce the same exposure.	Recommended for most situations.
A Aperture-priority auto	User chooses aperture: camera sets shutter speed for best results.	Large apertures (small f/-numbers) soften background details and let more light into camera, increasing range of flash. Small apertures (large f/-numbers) increase depth of field, bringing main subject and background into focus.

More on Photography

P: Programmed Auto

1

Rotate the mode dial to **P**.

2



Frame picture, focus, and shoot.

Flexible Program

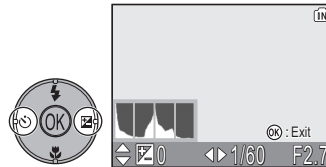
In **P** mode, different combinations of shutter speed and aperture can be selected by pressing the multi selector right ("flexible program"). Press the multi selector right or left to switch from one to the other. While flexible program is in effect, shutter speed and aperture are displayed yellow (otherwise, they are displayed white), and an asterisk ("*") appears next to the exposure mode indicator in the shooting display. Default values can be restored by turning the camera off.

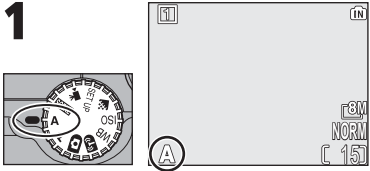
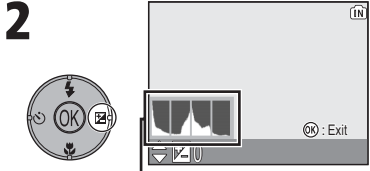
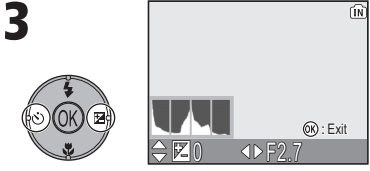

A: Aperture-Priority Auto

<p>1</p>  <p>Rotate the mode dial to A.</p>	<p>2</p>  <p>Histogram</p> <p>Display value for exposure compensation (exposure compensation setting screen) and histogram (distribution of tones).</p>
<p>3</p>  <p>Select aperture.</p>	<p>4</p>  <p>Frame picture, focus, and shoot.</p>

More on Photography

If the selected aperture would result in the picture being under- or over-exposed, the aperture display in the monitor will flash when the shutter-release button is pressed halfway. Choose another aperture and try again. An aperture of f/XXX may not be available at some zoom positions. For smaller apertures, try zooming the camera out.

Aperture and Zoom

The maximum and minimum values for aperture are determined by the camera lens and zoom setting. Unless **On** is chosen for **Fixed aperture** ()100, aperture will change as the camera is zoomed in or out. If the second-highest aperture setting is selected with the camera zoomed all the way out and the camera is then zoomed in, the camera will vary the f/-number to maintain aperture at the second-highest setting for the current zoom position.

Faster Shutter Speeds

Depending on the amount of light available, it may be possible to achieve shutter speeds as high as 1/2,000 s by selecting an aperture of f/XXX (maximum zoom) or between f/XXX and f/XXX (widest angle).

Controlling File Size: Selecting Image Quality and Size

The size of the files, and with it the number of images that can be recorded on the memory or the memory card, depends on the size and quality of the images. Before shooting, choose an image quality and size according to how you plan to use the picture.

Image Quality

The process of reducing the file size of a picture when storing it is called compression. In this camera, pictures are compressed and recorded as JPEG files.

The more a picture is compressed, the smaller the picture size becomes and the larger the number of pictures that can be stored in memory or on a memory card. However, the quality of the image is degraded and the reproducibility of the image's fine areas is reduced.

The less a picture is compressed, the larger the picture size becomes and the smaller the number of pictures that can be stored in memory or on a memory card. However, it maintains the presentation of the image's fine areas and increases the image quality.

Select from the following three options.

Option	Description	Compression
FINE FINE	Fine image quality, suitable for enlargements or high quality prints. File size reduced to roughly 1/4 of its original size.	
NORM NORMAL (default setting)	Normal image quality, suited to most applications. File size reduced to roughly 1/8 of its original size.	
BASIC BASIC	Basic image quality, suitable for pictures that will be distributed by e-mail or used in web pages. File size reduced to roughly 1/16 of its original size.	

More on Photography

Image Size

Smaller images create smaller files suitable for transmission by e-mail or for use in web pages.

When printed in larger sizes, however, small images will be rough and uneven in appearance. The size of images when printed depends on the printer resolution: the higher the resolution, the smaller the final print size.

Select from the following options according to your shooting intent.

Image size (pixels)	Print size (cm)*
8M 3264 × 2448 (default setting for P1)	28 × 21 (11" × 8")
5M 2592 × 1944 (default setting for P2)	22 × 16 (8.6" × 6.5")
3M 2048 × 1536	17 × 13 (6.7" × 5.1")
2M 1600 × 1200	14 × 10 (5.3" × 4")
1M 1280 × 960	11 × 8 (4" × 3")
PC 1024 × 768	9 × 7 (3.4" × 2.6")
TV 640 × 480	5 × 4 (2.1" × 1.6")
3.2 3264 × 2176 (for P1)	28 × 18 (11" × 7")
3.2 2592 × 1728 (for P2)	28 × 15 (11" × 5.8")

* All figures are approximate. Print sizes assume a printer resolution of approximately 300dpi. The size of images when printed depends on the printer resolution: the higher the resolution, the smaller the final print size.

To choose image quality or size:

More on Photography

1

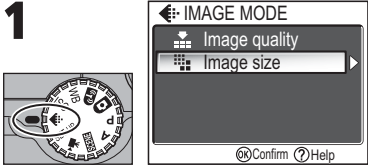
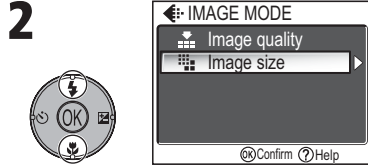

IMAGE MODE menu is displayed.

2



Highlight **Image quality** or **Image size** and press **OK**.

3

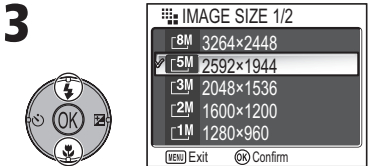

Highlight option and press **OK**.

6

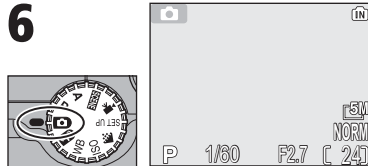

Rotate mode dial to **SCENE**, **P**, **A** or **Shoot & Transfer** (when **Shoot & Transfer** is selected.). Current image quality and size displayed in monitor.

The Shooting Menu

Image quality and size can also be set in the Shooting menu (p. 86).