

Nikon

DIGITAL CAMERA

COOLPIX B500

Quick Start Guide



For Smart Device Users	ii
Introduction	iv
Parts of the Camera	1
Getting Started	2
Basic Shooting and Playback Operations	12
Other Functions	17
Technical Notes	22

En

- ☒ Read this manual thoroughly before using the camera.
- ☒ To ensure proper use of the camera, be sure to read •For Your Safety☒(page viii).
- ☒ After reading this manual, keep it in a readily accessible place for future reference.

SnapBridge



Your images. The world. Connected

Welcome to SnapBridge — Nikon's new family of services to enrich your image experience. SnapBridge eliminates the barrier between your camera and compatible smart device, through a combination of *Bluetooth*® low energy (BLE) technology and a dedicated app. The stories you capture with your Nikon camera and lenses are automatically transferred to the device as they are taken. They can even be uploaded effortlessly to cloud storage services, inviting access across all your devices. You can share your excitement, when and where you want.

Download the SnapBridge app to get started!



Take advantage of the wide-ranging convenience by downloading the SnapBridge app onto your smart device now. Through a few simple steps, this app connects your Nikon cameras with a compatible iPhone®, iPad® or smart devices running on the Android™ operating system. The app is available free from the website (<http://snapbridge.nikon.com>), Apple App StoreSM and Google PlayTM.



COOLPIX B500 Model Name: N1516

ii For Smart Device Users

En_01

The exciting image experience that SnapBridge offers...



Automatic picture transfer from camera to smart device thanks to the constant connection between the two devices — making online photo sharing easier than ever

NIKON IMAGE SPACE



Upload of photos and thumbnail images to the NIKON IMAGE SPACE cloud service

A range of services that enriches your imaging life, including:

- Camera remote control
- Imprinting up to two pieces of credit information (e.g. copyright, comments, text and logos) on pictures
- Automatic update of camera's date and time info and location info
- Receive camera's firmware updates



For Smart Device Users

iii

Introduction

Read This First

Thank you for purchasing the Nikon COOLPIX B500 digital camera.

Downloading the Reference Manual

The Reference Manual (PDF format) provides more details in various languages on how to use this camera. Use your smart device or computer to refer to it along with this manual. Download the Reference Manual from our Download Center at the URL below.

- The Reference Manual can be viewed using Adobe PDF Reader, iBooks, or other software. Adobe PDF reader can be downloaded from the Adobe website.

Downloading ViewNX-i

ViewNX-i is free software that enables you to transfer images and movies to your computer for viewing and editing. Download the software from our Download Center at the URL below.

Visit Our Download Center

Visit the website below to download the Reference Manual and software for this camera.

<http://downloadcenter.nikonimglib.com>



Scan this image with your smart device's QR code reader.

Nikon User Support

Should you need technical support, we offer a number of options.

Internet

For customers in the United States: www.nikonusa.com

For customers in Canada: www.nikon.ca (English), fr.nikon.ca (Français)

For customers in Mexico: www.nikon.com.mx

For customers in Brazil: www.nikon.com.br

Telephone

For customers in the United States: **1-800-NIKON-US (1-800-645-6687)**

For customers in Canada: **1-877-534-9910**

For customers in Mexico: **001-888-565-5452**

For customers in Brazil: **0800-886-4566 (0800-88 NIKON)**

Confirming the Package Contents

In the event that any items are missing, please contact the store where you purchased the camera.



- COOLPIX B500
Digital Camera



- Camera Strap



- LR6/L40 (AA-size)
alkaline batteries (x4)*



- LC-CP31 Lens Cap
(with cord)

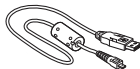

- UC-E16 USB Cable

- Quick Start Guide
(this manual)

- Warranty

* The included batteries are for trial use only.

NOTE: A memory card is not included with the camera. SD, SDHC, and SDXC memory cards are referred to as "memory cards" in this manual.

Information and Precautions

Life-Long Learning

As part of Nikon's "Life-Long Learning" commitment to ongoing product support and education, continually updated information is available online at the following websites:

- For users in the U.S.A.: <http://www.nikonusa.com/>
- For users in Europe: <http://www.europe-nikon.com/support/>
- For users in Asia, Oceania, the Middle East, and Africa: <http://www.nikon-asia.com/>

Visit these websites to keep up-to-date with the latest product information, tips, answers to frequently asked questions (FAQs), and general advice on digital imaging and photography. Additional information may be available from the Nikon representative in your area. Visit the website below for contact information.

<http://imaging.nikon.com/>

Use Only Nikon Brand Electronic Accessories

Nikon COOLPIX cameras are designed to the highest standards and include complex electronic circuitry. Only Nikon brand electronic accessories (including battery chargers, batteries, and AC adapters) certified by Nikon specifically for use with this Nikon digital camera are engineered and proven to operate within the operational and safety requirements of this electronic circuitry.

THE USE OF NON-NIKON ELECTRONIC ACCESSORIES COULD DAMAGE THE CAMERA AND MAY VOID YOUR NIKON WARRANTY.

For more information about Nikon brand accessories, contact a local authorized Nikon dealer.

Before Taking Important Pictures

Before taking pictures on important occasions (such as at weddings or before taking the camera on a trip), take a test shot to ensure that the camera is functioning normally. Nikon will not be held liable for damages or lost profits that may result from product malfunction.

About the Manuals

- No part of the manuals included with this product may be reproduced, transmitted, transcribed, stored in a retrieval system, or translated into any language in any form, by any means, without Nikon's prior written permission.
- Illustrations and screen content shown in this manual may differ from the actual product.
- Nikon reserves the right to change the specifications of the hardware and software described in these manuals at any time and without prior notice.
- Nikon will not be held liable for any damages resulting from the use of this product.
- While every effort was made to ensure that the information in these manuals is accurate and complete, we would appreciate it were you to bring any errors or omissions to the attention of the Nikon representative in your area (address provided separately).

Comply with Copyright Notices

Under copyright law, photographs or recordings of copyrighted works made with the camera can not be used without the permission of the copyright holder. Exceptions apply to personal use, but note that even personal use may be restricted in the case of photographs or recordings of exhibits or live performances.

Disposing of Data Storage Devices

Please note that deleting images or formatting data storage devices such as memory cards or built-in camera memory does not completely erase the original image data. Deleted files can sometimes be recovered from discarded storage devices using commercially available software, potentially resulting in the malicious use of personal image data. Ensuring the privacy of such data is the user's responsibility.

Before discarding a data storage device or transferring ownership to another person, make sure to reset all of the camera's settings in **Reset all** in the setup menu (p.20). After resetting, erase all data in the device using commercial deletion software, or format the device in **Format memory** or **Format card** in the setup menu (p.20), then completely refill it with images containing no private information (for example, images of empty sky).

Care should be taken to avoid injury or damage to property when physically destroying memory cards.

Conformity Marking

Follow the procedure below to display some of the conformity markings that the camera complies with.

Press the **MENU** button → **Y** menu icon → Conformity marking → **OK** button

For Your Safety

To prevent damage to property or injury to yourself or to others, read "For Your Safety" in its entirety before using this product.

Keep these safety instructions where all those who use this product will read them.



DANGER

Failure to observe the precautions marked with this icon carries a high risk of death or severe injury.



WARNING

Failure to observe the precautions marked with this icon could result in death or severe injury.



CAUTION

Failure to observe the precautions marked with this icon could result in injury or property damage.



WARNING

- Do not use while walking or operating a motor vehicle. Failure to observe this precaution could result in accidents.
- Do not disassemble or modify this product. Do not touch internal parts that become exposed as the result of a fall or other accident. Failure to observe these precautions could result in electric shock or other injury.
- Should you notice any abnormalities such as the product producing smoke, heat, or unusual odors, immediately disconnect the batteries or power source. Continued operation could result in fire, burns or other injury.
- Keep dry. Do not handle with wet hands. Do not handle the plug with wet hands. Failure to observe these precautions could result in fire or electric shock.
- Do not let your skin remain in prolonged contact with this product while it is on or plugged in. Failure to observe this precaution could result in low-temperature burns.
- Do not use this product in the presence of flammable dust or gas such as propane, gasoline or aerosols. Failure to observe this precaution could result in explosion or fire.
- Do not aim the flash at the operator of a motor vehicle. Failure to observe this precaution could result in accidents.

- Keep this product out of reach of children. Failure to observe this precaution could result in injury or product malfunction. In addition, note that small parts constitute a choking hazard. Should a child swallow any part of this product, seek immediate medical attention.
- Do not entangle, wrap or twist the strap around your neck. Failure to observe this precaution could result in accidents.
- Do not use batteries, chargers, or AC adapters not specifically designated for use with this product. When using batteries, chargers, and AC adapters designated for use with this product, do not:
 - Damage, modify, forcibly tug or bend the cords or cables, place them under heavy objects, or expose them to heat or flame.
 - Use travel converters or adapters designed to convert from one voltage to another or with DC-to-AC inverters.Failure to observe these precautions could result in fire or electric shock.
- Do not handle the plug when using the AC adapter during thunderstorms. Failure to observe this precaution could result in electric shock.
- Do not handle with bare hands in locations exposed to extremely high or low temperatures. Failure to observe this precaution could result in burns or frostbite.

CAUTION

- Turn this product off when its use is prohibited. Disable wireless features when the use of wireless equipment is prohibited. The radio-frequency emissions produced by this product could interfere with equipment onboard aircraft or in hospitals or other medical facilities.
- Remove the batteries and disconnect the AC adapter if this product will not be used for an extended period. Failure to observe this precaution could result in fire or product malfunction.
- Do not touch moving parts of the lens or other moving parts. Failure to observe this precaution could result in injury.
- Do not fire the flash in contact with or in close proximity to the skin or objects. Failure to observe this precaution could result in burns or fire.
- Do not leave the product where it will be exposed to extremely high temperatures, for an extended period such as in an enclosed automobile or in direct sunlight. Failure to observe this precaution could result in fire or product malfunction.

DANGER for Batteries

- Do not mishandle batteries. Failure to observe the following precautions could result in the batteries leaking, overheating, rupturing, or catching fire:
 - Do not attempt to recharge non-rechargeable batteries.
 - Do not expose batteries to flame or excessive heat.
 - Do not disassemble.
 - Do not short circuit the terminals by touching them to necklaces, hairpins, or other metal objects.
 - Do not expose batteries or the products in which they are inserted to powerful physical shocks.
- Recharge all EN-MH2 rechargeable batteries in each pack of four simultaneously. Failure to observe this precaution could result in the batteries leaking, overheating, rupturing, or catching fire.
- If battery liquid comes into contact with the eyes, rinse with plenty of clean water and seek immediate medical attention. Delaying action could result in eye injuries.

WARNING for Batteries

- Do not remove or damage the battery casing. Never use batteries with damaged casing. Failure to observe this precaution could result in the batteries leaking, overheating, rupturing, or catching fire.
- Keep batteries out of reach of children. Should a child swallow a battery, seek immediate medical attention.
- Do not immerse this product in water or expose to rain. Failure to observe this precaution could result in fire or product malfunction. Immediately dry the product with a towel or similar object should it become wet.
- Discontinue use immediately should you notice any changes in the batteries, such as discoloration or deformation. Cease charging EN-MH2 rechargeable batteries if they do not charge in the specified period of time. Failure to observe this precaution could result in the batteries leaking, overheating, rupturing, or catching fire.
- Insert batteries in the correct orientation. Do not mix old and new batteries or batteries of different types. Failure to observe this precaution could result in the batteries leaking, overheating, rupturing, or catching fire.
- Prior to disposal, insulate battery terminals with tape. Overheating, rupture, or fire may result should metal objects come into contact with the terminals. Recycle or dispose of batteries in accord with local regulations.

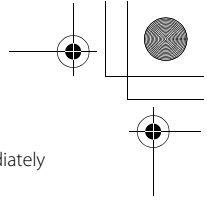
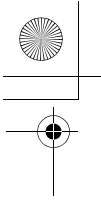

- If battery liquid comes into contact with a person's skin or clothing, immediately rinse the affected area with plenty of clean water. Failure to observe this precaution could result in skin irritation.

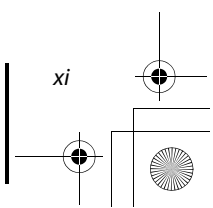
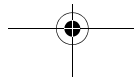
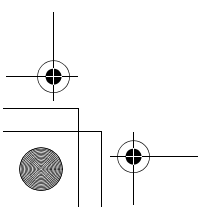
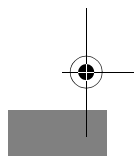
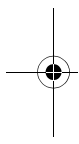



A series of horizontal dashed lines for writing, spanning the width of the page.

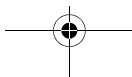
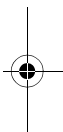

Parts of the Camera

The Camera Body

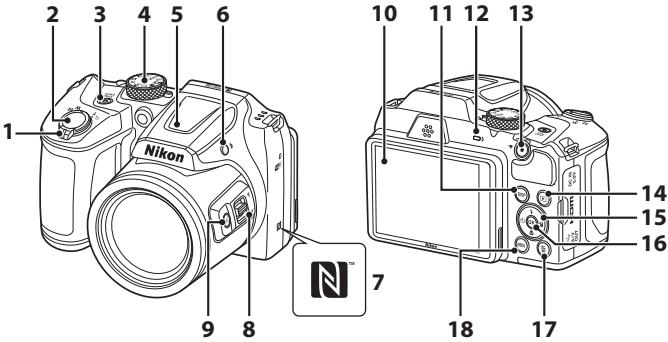

- Zoom control
W : Wide-angle
T : Telephoto
 : Thumbnail playback
 : Playback zoom
- 1** Shutter-release button
- 2** Shutter-release button
- 3** Power switch/power-on lamp
- 4** Mode dial
- 5** Flash
- 6** (flash pop-up) button
- 7** N-Mark (NFC antenna)
- 8** Side zoom control
- 9** (snap-back zoom) button

- 10** Monitor
- 11** **DISP** (display) button
- 12** Flash lamp
- 13** (movie-record) button
- 14** (playback) button
- 15** Multi selector
- 16** (apply selection) button
- 17** (delete) button
- 18** **MENU** (menu) button

Getting Started

How to Attach the Camera Strap and Lens Cap

Attach the lens cap to the camera strap, and then attach the strap to the camera.

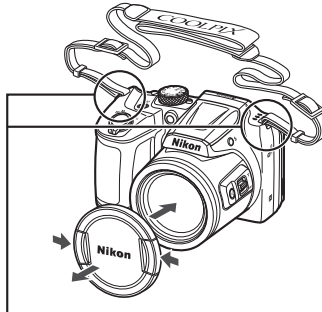
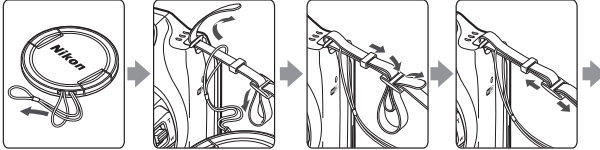

Attach the strap at two places.

Lens Cap

When the camera is not in use, attach the lens cap to the lens to protect it.

Inserting the Batteries and Memory Card

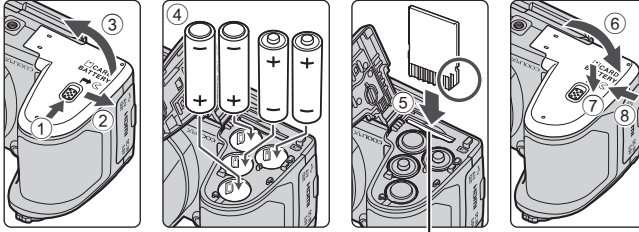

Memory card slot

- Hold the camera upside down to prevent the batteries from falling out, confirm that the positive (+) and negative (-) terminals of the batteries are oriented correctly, and insert the batteries.
- Slide the memory card in until it clicks into place (5).
- Be careful not to insert the batteries or memory card upside-down or backward, as this could cause a malfunction.
- When closing the cover, slide it while securely holding down the area marked (7).

Formatting a Memory Card

The first time you insert a memory card that has been used in another device into this camera, make sure to format it with this camera. Insert the memory card into the camera, press the **MENU** button, and select **Format card** in the setup menu (20).

Applicable Batteries

- Four LR6/L40 (AA-size) alkaline batteries (included batteries)
 - Four FR6/L91 (AA-size) lithium batteries
 - Four EN-MH2 Rechargeable Ni-MH (nickel metal hydride) batteries
- EN-MH1 Rechargeable Ni-MH batteries cannot be used.

✓ Notes About the Batteries

- Do not combine old and new batteries or batteries of different makes or types.
- Batteries with the following defects cannot be used:

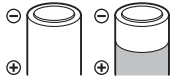

Batteries with peeling



Batteries with insulation that does not cover the area around the negative terminal

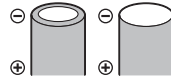

Batteries with a flat negative terminal

✓ Notes About EN-MH2 Rechargeable Ni-MH Batteries

When using EN-MH2 batteries with the camera, charge four batteries at a time using MH-73 Battery Charger (📖27).

✍ Alkaline Batteries

Performance of alkaline batteries may vary greatly depending on the brand.

Removing the Batteries or Memory Card

Turn the camera off and make sure that the power-on lamp and screen have turned off, and then open the battery-chamber/memory card slot cover.

- Gently push the memory card into the camera to partially eject the memory card.
- Be careful when handling the camera, batteries, and memory card immediately after using the camera, as they may be hot.

Memory Cards and Internal Memory

Camera data, including images and movies, can be saved either on a memory card or in the camera's internal memory. To use the camera's internal memory, remove the memory card.

Changing the Angle of the Monitor

The angle of the monitor can be lowered down to approx. 85° or raised upward to approx. 90°.

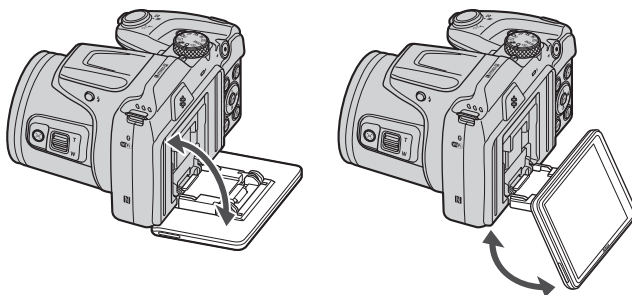

✓ Notes About the Monitor

- Do not apply excessive force when changing the angle of the monitor.
- The monitor cannot be moved to the left or right.
- Put the monitor back in the original position when using in normal situations.

Camera Setup

Setup from a Smartphone or Tablet

- Before proceeding, install the SnapBridge app (📖ii) and enable Bluetooth and Wi-Fi on your smartphone or tablet (below, “smart device”).
- The camera and smart device screens shown in this manual may differ from those of the actual products.



1 Turn the camera on.

- Use the multi selector to select and adjust settings.

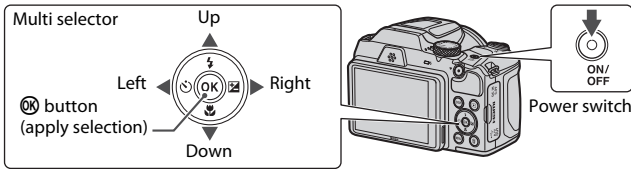

- A language selection dialog will be displayed. Press ▲ or ▼ on the multi selector to highlight a language and press OK to select.
- The language can be changed at any time using the **Language** option in the setup menu (📖20).

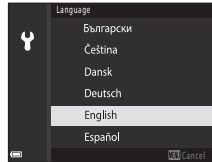

2 Press OK when the dialog at right is displayed.

- If you do not wish to use a smart device to configure the camera, press **MENU** (📖8).

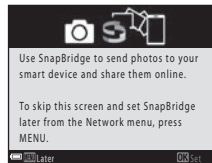

3 Pair (i.e., establish a Bluetooth link between) the camera and the smart device.

- **Android Devices with NFC Support**

After checking that NFC is enabled on the smart device, touch the camera  (N-Mark) to the NFC antenna on the smart device to launch the SnapBridge app.

- If the SnapBridge download site is displayed, download and install the app before repeating the above steps.

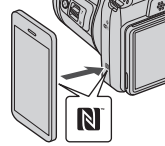

- **iOS Devices and Android Devices Without NFC Support**

Press the camera  button. The camera will wait for a connection; launch the SnapBridge app on the smart device and follow the on-screen instructions to tap the name of the camera you want to pair with.

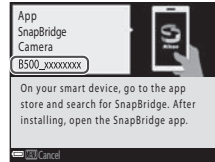

4 Check the authentication code.

- After confirming that the camera and smart device display the same six-digit authentication code, follow the steps below to complete pairing.
 - **On the camera**, press .
 - **On the smart device**, tap **Pairing** (the name of the button varies with the smart device).

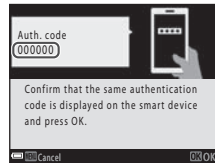

Camera

5 Press **OK** when the dialog at right is displayed.

- When a constant connection between the camera and smart device is established, the dialog at right is displayed.
- If the camera displays **Could not connect.**, press **OK** to return to Step 3. To cancel pairing settings, press **MENU**.

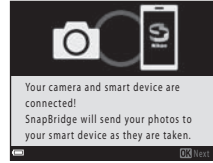

6 Follow the on-screen instructions to complete the setup process.

- To record location data with photographs, select **Yes** when prompted and enable the location data features both in the SnapBridge app and on the smart device itself (for more information, see the documentation provided with the smart device).
- You can also synchronize the camera clock to the time reported by the smart device by selecting **Yes** when prompted and enabling synchronization in the SnapBridge app. If you select **No**, set the camera clock from the menus as described in Step 2 on page 9.
- Setup is complete when the camera returns to the shooting display.
- See page 10 for more information on using SnapBridge.

Setup from the Camera Menus

The camera clock can be set manually.

1 Turn the camera on (16).

- A language selection dialog will be displayed. Press **▲** or **▼** on the multi-selector (16) to highlight a language and press **OK** to select.
- The language can be changed at any time using the **Language** option in the setup menu (20).

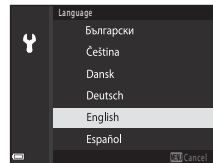

8 Getting Started

En_01

2 Press **MENU** when the dialog at right is displayed.

- Select **Yes** when prompted to set the camera clock.

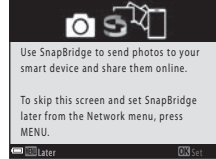
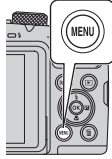

3 Highlight your home time zone and press **OK**.

- To turn daylight saving time on press **▲** will be displayed at the top of the map. Press **▼** to turn daylight saving time off.

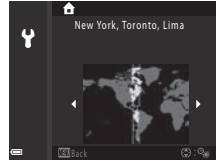

4 Press **▲** or **▼** to choose a date format and press **OK**.

5 Enter the current date and time and press **OK**.

- Press **◀** or **▶** to highlight items and press **▲** or **▼** to change.
- Press **OK** to set the clock.

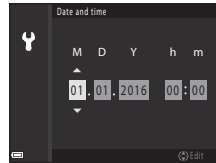

6 When prompted, press **▲** or **▼** to highlight **Yes** and press **OK**.

- The camera exits to the shooting display when setup is complete.

Resetting the Clock

The **Time zone and date** option in the setup menu can be used to choose the time zone and set the camera clock.

Daylight saving time can be turned on or off in the **Time zone** menu.

What SnapBridge Can Do for You

The SnapBridge app can be used for a variety of tasks once the camera has been paired with your smart device.



Auto Upload

At default settings, pictures will automatically be uploaded to the smart device as they are taken.

- Place the smart device close to the camera and launch the SnapBridge app.

Option	Description
Disabling auto upload	Auto upload can be disabled using the Send while shooting > Still images options in the camera network menu (□□20).
Upload options	Use the Send while shooting item in the camera network menu to choose the types of pictures automatically uploaded.
Selecting pictures for upload	You can use this option to automatically upload selected pictures that were not uploaded during shooting. <ul style="list-style-type: none"> • Use the Mark for upload option in the camera playback menu (□□20) to select pictures. • The constant connection ensures that upload will continue even when the camera is off.
Resizing pictures for upload	Use the SnapBridge app to choose the size at which pictures are copied to the smart device. The default size is 2 megapixels.
Embedding photo info	Use the SnapBridge app to choose the information imprinted on photographs copied to the smart device. Comments and copyright information can be entered in advance from the camera setup menu. You can also imprint text entered in the SnapBridge app.

Wireless Networks

Option	Description
Pairing	To pair the camera with a smart device (for example, with a new device or if you did not opt to pair with a smart device during setup), select Connect to smart device in the camera network menu and follow the instructions on page 7, starting with Step 3. The camera can be paired with up to five smart devices, but can connect to only one at a time.
Uploading pictures via Wi-Fi	A Wi-Fi connection is recommended for movies and large-volume uploads. Follow the on-screen instructions in the SnapBridge app to switch to a Wi-Fi connection. <ul style="list-style-type: none"> The Wi-Fi > Network settings item in the camera network menu contains Auth./encryp. and Password options. The default option for Auth./encryp. is WPA2-PSK-AES.

Where the Use of Wireless Devices Is Prohibited

Where the use of wireless devices is prohibited, disable wireless features in the camera network menu by selecting **On** for **Airplane mode**. This will temporarily interrupt the constant connection with the smart device, but the connection is automatically re-established when airplane mode is turned off.

Other Options for the SnapBridge App

Option	Description
Remote photography	Use the smart device to release the camera shutter. Before performing remote photography, turn the camera on.
Viewing the pictures on the camera	Use the smart device to view and download the pictures on the camera. This option is available even when the camera is off.

- See SnapBridge app online help for more information.

Basic Shooting and Playback Operations

Shooting Images

(auto) mode is used here as an example. (auto) mode enables you to perform general shooting in a variety of shooting conditions.

1 Rotate the mode dial to .

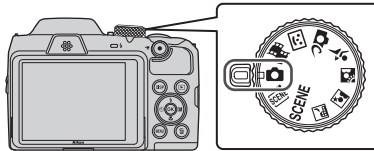

- Battery level indicator
: The battery level is high.
: The battery level is low.
- Number of exposures remaining
 is displayed when no memory card is inserted in the camera, and images are saved in the internal memory.
- Press the **DISP** (display) button to switch the information displayed on the screen each time.

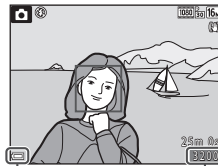

Battery level indicator
 Number of exposures remaining

2 Hold the camera steady.

- Keep fingers and other objects away from the lens, flash, AF-assist illuminator, microphone, and speaker.

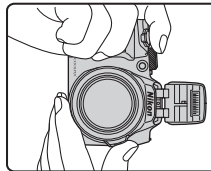
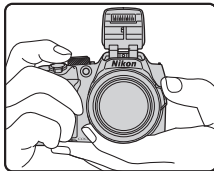

3 Frame the picture.

- Move the zoom control or the side zoom control to change the zoom lens position.
- If you lose sight of the subject while shooting with the lens in telephoto position, press the  (snap-back zoom) button to temporarily widen the visible area so that you can frame the subject more easily.

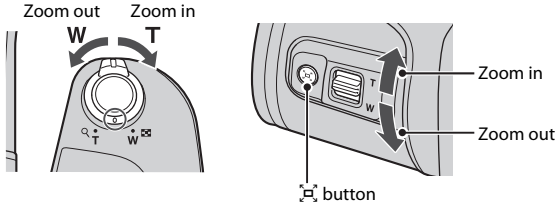

4 Press the shutter-release button halfway.

- To press the shutter-release button "halfway" means to press and hold the button at the point where you feel a slight resistance.
- When the subject is in focus, the focus area or focus indicator is displayed in green.
- When you are using digital zoom, the camera focuses in the center of the frame and the focus area is not displayed.
- If the focus area or focus indicator flashes, the camera is unable to focus. Modify the composition and try pressing the shutter-release button halfway again.

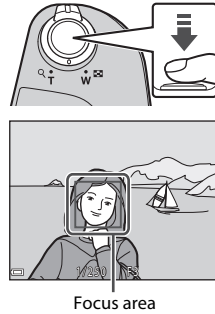

5 Without lifting your finger, press the shutter-release button all the way down.



Notes About Saving Images or Movies

The indicator showing the number of exposures remaining or the indicator showing the remaining recording time flashes while images or movies are being saved. **Do not open the battery-chamber/memory card slot cover or remove the batteries or memory card** while an indicator is flashing. Doing this could result in loss of data, or in damage to the camera or the memory card.

The Auto Off Function

- When no operations are performed for about one minute, the screen turns off, the camera enters standby mode, and then the power-on lamp flashes. The camera turns off after remaining in standby mode for about three minutes.
- To turn the screen back on while the camera is in standby mode, perform an operation such as pressing the power switch or shutter-release button.

When Using a Tripod

- We recommend using a tripod to stabilize the camera in the following situations:
 - When the flash is lowered in dark locations or when using a shooting mode in which the flash does not fire
 - When the zoom is at a telephoto position
- When using a tripod to stabilize the camera during shooting, set **Photo VR** to **Off** in the setup menu (☰20) to prevent potential errors caused by this function.



Using the Flash

In situations where a flash is needed, such as in dark locations or when the subject is backlit, press the  (flash pop-up) button to raise the flash.

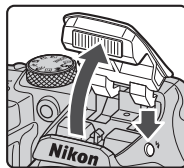
- When not using the flash, gently push to lower the flash until it clicks shut.



Recording Movies

Display the shooting screen and press the  (movie-record) button to start recording a movie. Press the  button again to end recording.

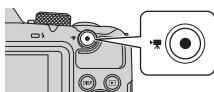



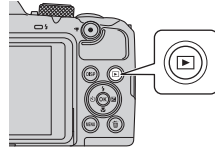

Playing Back Images

1 Press the (playback) button to enter playback mode.

- If you press and hold down the  button while the camera is turned off, the camera turns on in playback mode.



2 Use the multi selector to select an image to display.

- Press and hold down     to scroll through the images quickly.
- Press the **DISP** (display) button to switch the information displayed on the screen each time.
- To play back a recorded movie, press the **OK** button.
- To return to shooting mode, press the  button or shutter-release button.
- When **OK: [E]** is displayed in full-frame playback mode, you can press the **OK** button to apply an effect to the image.

Display the previous image

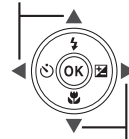

Display the next image

- Move the zoom control toward **T** () in full-frame playback mode to zoom in on an image.







- In full-frame playback mode, move the zoom control toward **W** () to switch to thumbnail playback mode and display multiple images on the screen.

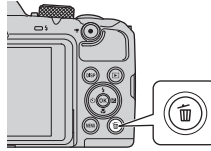

Deleting Images

- 1 Press the  (delete) button to delete the image currently displayed on the screen.



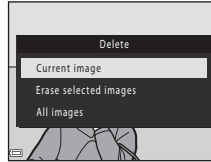

- 2 Use the multi selector   to select the desired deletion method and press the  button.
 - To exit without deleting, press the **MENU** button.

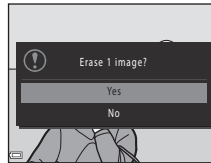

- 3 Select **Yes** and press the  button.
 - Deleted images cannot be recovered.



Deleting Images in a Sequence

- Images captured continuously, or with the multiple exp. lighten, creative mode, or self-collage function, are saved as a sequence, and only one image in the sequence (the key picture) is displayed in playback mode (default setting).
- If you press the  button while a key picture is displayed for a sequence of images, all images in the sequence are deleted.
- To delete individual images in a sequence, press the  button to display them one at a time and press the  button.



Deleting the Image Captured While in Shooting Mode









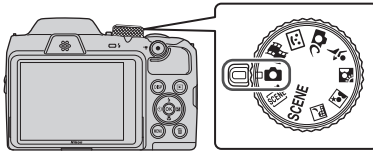







When using shooting mode, press the  button to delete the last image that was saved.

Other Functions

Selecting a Shooting Mode

You can rotate the mode dial to align the desired shooting mode with the indicator mark on the camera body.



-  **(Auto) mode**
Select this mode to perform general shooting in a variety of shooting conditions.
- **SCENE**, , , , ,  **(Scene) modes**
Select any one of scene modes based on the shooting conditions, and you can take pictures with the appropriate settings for those conditions.
 - **SCENE**: Press the **MENU** button and select a scene mode.
 -  (scene auto selector): The camera recognizes the shooting conditions when you frame a picture, and you can take pictures in accordance with the conditions.
 -  (night landscape): Use this mode to shoot night landscapes.
 -  (night portrait): Use this mode to shoot evening and night portraits that include background scenery.
 -  (backlighting): Use this mode to shoot backlit subjects.
 -  (sports): Use this mode to shoot sports photos.
-  **(Creative) mode**
The camera saves four images with effects and one image without effects simultaneously in one shot.
-  **(Smart portrait) mode**
Use glamour retouch to enhance human faces during shooting, and use the smile timer or self-collage function to take pictures.
-  **(Short movie show) mode**
The camera creates a short movie that is up to 30 seconds long ( **1080/30p** or  **1080/25p**) by recording and automatically combining multiple movie clips that are several seconds long.



Help Display

The descriptions of functions are displayed while changing the shooting mode or while the setting screen is displayed.

Press the shutter-release button halfway to quickly switch to shooting mode. You can show or hide the descriptions using **Help display** in **Monitor settings** in the setup menu.

Setting Shooting Functions with the Multi Selector

When the shooting screen is displayed, you can press the multi selector to set the functions described below.







- **Flash mode**
When the flash is raised, the flash mode can be set according to shooting conditions.
- **Self-timer**
The camera releases the shutter 10 seconds, 5 seconds, or 2 seconds after you press the shutter-release button.
- **Macro mode**
Use macro mode when you take close-up pictures.
- **Exposure compensation**
You can adjust overall image brightness.

The functions that can be set vary depending on the shooting mode.

Menu Operations

You can set the menus listed below by pressing the **MENU** (menu) button.

-  **Shooting menu**^{1,2}
-  **Movie menu**¹
-  **Playback menu**³
-  **Network menu**
-  **Setup menu**

¹ Press the **MENU** button when the shooting screen is displayed.

² Menu icons and available setting options vary depending on the shooting mode.

³ Press the **MENU** button when the playback screen is displayed. Menu icons and available setting options vary depending on the playback mode.

1 Press the **MENU** (menu) button.

- The menu is displayed.

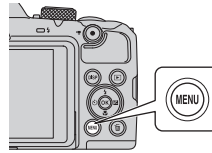

2 Press the multi selector ◀.

- The current menu icon is displayed in yellow.



Menu icons

3 Select a menu icon and press the **OK** button.

- The menu options become selectable.

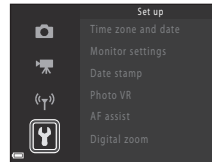

4 Select a menu option and press the **OK** button.

- Certain menu options cannot be set depending on the current shooting mode or the state of the camera.

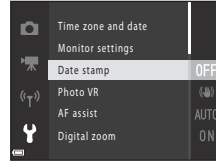

5 Select a setting and press the **OK** button.

- The setting you selected is applied.
- When you are finished using the menu, press the **MENU** button.
- When a menu is displayed, you can switch to shooting mode by pressing the shutter-release button or **(P)** button.

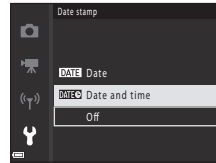

Technical Notes

Notices

Notices for Customers in the U.S.A.

Federal Communications Commission (FCC) Radio Frequency Interference Statement

This equipment has been tested and found to comply with the limits for a Class B digital device, pursuant to Part 15 of the FCC rules. These limits are designed to provide reasonable protection against harmful interference

in a residential installation. This equipment generates, uses, and can radiate radio frequency energy and, if not installed and used in accordance with the instructions, may cause harmful interference to radio communications. However, there is no guarantee that interference will not occur in a particular installation. If this equipment does cause harmful interference to radio or television reception, which can be determined by turning the equipment off and on, the user is encouraged to try to correct the interference by one or more of the following measures:

- Reorient or relocate the receiving antenna.
- Increase the separation between the equipment and receiver.
- Connect the equipment into an outlet on a circuit different from that to which the receiver is connected.
- Consult the dealer or an experienced radio/television technician for help.



Nikon
COOLPIX B500

CAUTIONS

Modifications

The FCC requires the user to be notified that any changes or modifications made to this device that are not expressly approved by Nikon Corporation may void the user's authority to operate the equipment.

Interface Cables

Use the interface cables sold or provided by Nikon for your equipment. Using other interface cables may exceed the limits of Class B Part 15 of the FCC rules.

Notice for Customers in the State of California

WARNING

Handling the cord on this product will expose you to lead, a chemical known to the State of California to cause birth defects or other reproductive harm.

Wash hands after handling.

Nikon Inc.,
1300 Walt Whitman Road, Melville, New York 11747-3064, U.S.A.
Tel: 631-547-4200

Notice for Customers in Canada

CAN ICES-3 B / NMB-3 B

Notes About Wireless Communication Functions

Restrictions on Wireless Devices

The wireless transceiver included in this product conforms to wireless regulations in the country of sale and is not for use in other countries (products purchased in the EU or EFTA can be used anywhere within the EU and EFTA). Nikon does not accept liability for use in other countries. Users who are unsure as to the original country of sale should consult with their local Nikon service center or Nikon-authorized service representative. This restriction applies to wireless operation only and not to any other use of the product.

Security

Although one of the benefits of this product is that it allows others to freely connect for the wireless exchange of data anywhere within its range, the following may occur if security is not enabled:

- Data theft: Malicious third-parties may intercept wireless transmissions to steal user IDs, passwords, and other personal information.
- Unauthorized access: Unauthorized users may gain access to the network and alter data or perform other malicious actions. Note that due to the design of wireless networks, specialized attacks may allow unauthorized access even when security is enabled. Nikon is not responsible for data or information leaks that may occur during data transfer.
- Do not access networks that you are not permitted to use, even if they are displayed on your smartphone or tablet. Doing so may be regarded as unauthorized access. Only access networks that you are permitted to use.

Personal Information Management and Disclaimer

- User information registered and configured on the product, including wireless LAN connection settings and other personal information, is susceptible to alteration and loss resulting from operational error, static electricity, accident, malfunction, repair or other handling. Always keep separate copies of important information. Nikon is not responsible for any direct or indirect damages or lost profits resulting from alteration or loss of content that is not attributable to Nikon.
- Before discarding this product or transferring it to another owner, perform **Reset all** in the setup menu (📖20) to delete all user information registered and configured with the product, including wireless LAN connection settings and other personal information.
- Nikon is not responsible for any damages resulting from unauthorized use of this product by third parties in the event that the product is stolen or lost.

Precautions when Exporting or Carrying This Product Abroad

This product is controlled by the United States Export Administration Regulations (EAR). The permission of the United States government is not required for export to countries other than the following, which as of this writing are subject to embargo or special controls: Cuba, Iran, North Korea, Sudan, and Syria (list subject to change).

Notice for Customers in the U.S.A. and Canada

Federal Communications Commission (FCC) and Industry of Canada (IC)

Declaration of Conformity

This device complies with Part 15 of FCC Rules and Industry Canada licence-exempt RSS standard(s). Operation is subject to the following two conditions: (1) this device may not cause interference, and (2) this device must accept any interference, including interference that may cause undesired operation of this device.

RF Exposure Information (SAR)

This device meets the government's requirements for exposure to radio waves. This device is designed and manufactured not to exceed the emission limits for exposure to radio frequency (RF) energy set by the Federal Communications Commission of the U.S. Government.

The exposure standard employs a unit of measurement known as the Specific Absorption Rate, or SAR. The SAR limit set by the FCC is 1.6 W/kg. Tests for SAR are conducted using standard operating positions accepted by the FCC with the EUT transmitting at the specified power level in different channels.

The FCC has granted an Equipment Authorization for this device with all reported SAR levels evaluated as in compliance with the FCC RF exposure guidelines. SAR information on this device is on file with the FCC and can be found under the Display Grant section of www.fcc.gov/eot/ea/fccid after searching on FCC ID: CGJ 7152EB.

Caring for the Product

Observe the precautions described below in addition to the warnings in "For Your Safety" (ⓘviiiixi) when using or storing the device.

The Camera

Do Not Apply Strong Impact to the Camera

The product may malfunction if subjected to strong shock or vibration. In addition, do not touch or apply force to the lens.

Keep Dry

The device will be damaged if immersed in water or subjected to high humidity.

Avoid Sudden Changes in Temperature

Sudden changes in temperature, such as when entering or leaving a heated building on a cold day, can cause condensation to form inside the device. To prevent condensation, place the device in a carrying case or a plastic bag before exposing it to sudden changes in temperature.

Keep Away from Strong Magnetic Fields

Do not use or store this device in the vicinity of equipment that generates strong electromagnetic radiation or magnetic fields. Doing so could result in loss of data or camera malfunction.

Do Not Point the Lens at Strong Light Sources for Extended Periods

Avoid pointing the lens at the sun or other strong light sources for extended periods when using or storing the camera. Intense light may cause the image sensor to deteriorate or produce a white blur effect in photographs.

Turn the Product Off Before Removing or Disconnecting the Power Source or Memory Card

Do not remove the batteries while the product is on, or while images are being saved or deleted. Forcibly cutting power in these circumstances could result in loss of data or in damage to the memory card or internal circuitry.

Notes About the Monitor

- Monitors (including electronic viewfinders) are constructed with extremely high precision; at least 99.99% of pixels are effective, with no more than 0.01% being missing or defective. Hence while these displays may contain pixels that are always lit (white, red, blue, or green) or always off (black), this is not a malfunction and has no effect on images recorded with the device.
- Images in the monitor may be difficult to see under bright lighting.
- Do not apply pressure to the monitor, as this could cause damage or malfunction. Should the monitor break, care should be taken to avoid injury caused by broken glass and to prevent the liquid crystal from the display touching the skin or entering the eyes or mouth.

Batteries

Precautions for Use

- Note that the batteries may become hot after use.
- Do not use batteries beyond their recommended expiration date.
- Do not turn the camera on and off repeatedly if discharged batteries are inserted in the camera.

Carrying Spare Batteries

We recommend carrying spare batteries depending on where you are shooting. It may be difficult to purchase batteries in certain areas.

Charging Batteries

If using optional rechargeable batteries, charge the batteries before taking pictures. Batteries are not fully charged at the time of purchase.

Be sure to read and follow the warnings noted in the operating instructions included with the battery charger.

Charging Rechargeable Batteries

- Do not mix batteries with different amounts of charge remaining, or batteries of a different make or model.
- When using EN-MH2 batteries with this camera, charge four batteries at a time using MH-73 Battery Charger. Use only MH-73 Battery Charger to charge EN-MH2 batteries.
- When using MH-73 Battery Charger, only charge EN-MH2 batteries.
- EN-MH1 Rechargeable Ni-MH batteries cannot be used.

Notes About Rechargeable Ni-MH Batteries

- If you repeatedly charge rechargeable Ni-MH batteries while they still have some charge remaining, the message **Battery exhausted.** may be displayed prematurely when using the batteries. This is due to the "memory effect," in which the amount of charge the batteries can hold decreases temporarily. Use the batteries until there is no charge remaining and they will return to their normal behavior.
- Rechargeable Ni-MH batteries discharge even when not being used. We recommend charging the batteries just before using them.

Using the Batteries When Cold

On cold days, the capacity of batteries tends to decrease. If exhausted batteries are used at a low temperature, the camera may not turn on. Keep spare batteries in a warm place and exchange as necessary. Once warmed, cold batteries may recover some of their charge.

Battery Terminals

Dirt on the battery terminals may prevent the camera from functioning. Should the battery terminals become dirty, wipe them off with a clean, dry cloth before use.

Remaining Battery Charge

If you insert discharged batteries into the camera, the camera may indicate that the batteries have adequate charge remaining. This is a characteristic of batteries.

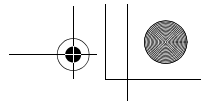

Recycling Used Batteries

Replace the batteries when they no longer hold a charge. Used batteries are a valuable resource. Please recycle used batteries in accordance with local regulations.

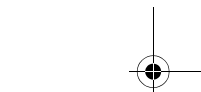
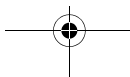
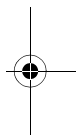
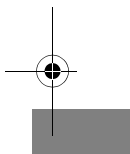

Cleaning and Storage

Cleaning

Do not use alcohol, thinner, or other volatile chemicals.

Lens	Avoid touching glass parts with your fingers. Remove dust or lint with a blower (typically a small device with a rubber bulb attached to one end that is pumped to produce a stream of air out the other end). To remove fingerprints or other stains that cannot be removed with a blower, wipe the lens with a soft cloth, using a spiral motion that starts at the center of the lens and working toward the edges. If this fails, clean the lens using a cloth lightly dampened with commercial lens cleaner.
Monitor	Remove dust or lint with a blower. To remove fingerprints and other stains, clean the monitor with a soft, dry cloth, being careful not to apply pressure.
Body	Use a blower to remove dust, dirt, or sand, then wipe gently with a soft, dry cloth. After using the camera at the beach or other sandy or dusty environment, wipe off any sand, dust, or salt with a dry cloth lightly dampened with fresh water and dry thoroughly. Note that foreign matter inside the camera could cause damage not covered by the warranty.

Storage

Remove the batteries if the camera will not be used for an extended period. To prevent mold or mildew, take the camera out of storage at least once a month. Turn the camera on and release the shutter a few times before putting the camera away again. Do not store the camera in any of the following locations:

- Places that are poorly ventilated or subject to humidity of over 60%
- Exposed to temperatures above 50°C (122°F) or below 10°C (50°F)
- Next to equipment that produces strong electromagnetic fields, such as televisions or radios

Troubleshooting

If the camera fails to function as expected, check the list of common problems below before consulting your retailer or Nikon-authorized service representative.

Also, refer to the Reference Manual (PDF format) for further details on how to use this camera (📖iv).

Problem	Cause/Solution	📖
The camera is on but does not respond.	<ul style="list-style-type: none"> • Wait for recording to end. • If the problem persists, turn the camera off. If the camera does not turn off, remove and reinsert the battery or batteries or, if you are using an AC adapter, disconnect and reconnect the AC adapter. Note that although any data currently being recorded will be lost, data that have already been recorded will not be affected by removing or disconnecting the power source. 	☒
The camera cannot be turned on.	The batteries are exhausted.	3, 27
The camera turns off without warning.	<ul style="list-style-type: none"> • The camera automatically turns off to save power (auto off function). • The camera and batteries may not work properly at low temperatures. • The inside of the camera has become hot. Leave the camera off until the inside of the camera has cooled, and then try turning it on again. 	14 27 ☒
The monitor is blank.	<ul style="list-style-type: none"> • The camera is off. • The camera automatically turns off to save power (auto off function). • The flash lamp flashes while the flash is charging. Wait until charging is complete. • The camera is connected to a TV or computer. • The camera is shooting in Multiple exp. Lighten scene mode. 	6 14 ☒ ☒ ☒
The camera becomes hot.	The camera may become hot when used for an extended period of time such as to shoot movies, or when used in a hot environment; this is not a malfunction.	☒

Memory Cards That Can Be Used

The camera supports SD, SDHC, and SDXC memory cards.

- Memory cards with an SD Speed Class rating of 6 or faster are recommended for recording movies. When using a memory card with a lower Speed Class rating, movie recording may stop unexpectedly.
- If you use a card reader, make sure that it is compatible with your memory card.
- Contact the manufacturer for information on features, operation, and limitations on use.

Trademark Information

- Windows is either a registered trademark or trademark of Microsoft Corporation in the United States and/or other countries.
- The *Bluetooth*[®] word mark and logos are registered trademarks owned by Bluetooth SIG, Inc. and any use of such marks by Nikon Corporation is under license.
- Apple[®], the Apple logos, Mac, OS X, iPhone[®], iPad[®] and iBooks are trademarks or registered trademarks of Apple Inc., in the U.S. and other countries. The App StoreSM is a service mark of Apple Inc.
- Android and Google Play are trademarks or registered trademarks of Google Inc. The Android robot is reproduced or modified from work created and shared by Google and used according to terms described in the Creative Commons 3.0 Attribution License.
- iOS is a trademark or registered trademark of Cisco Systems, Inc., in the United States and/or other countries and is used under license.
- Adobe, the Adobe logo, and Reader are either trademarks or registered trademarks of Adobe Systems Incorporated in the United States and/or other countries.
- SDXC, SDHC, and SD Logos are trademarks of SD-3C, LLC.



- PictBridge is a trademark.
- HDMI, HDMI logo and High-Definition Multimedia Interface are trademarks or registered trademarks of HDMI Licensing, LLC.

HDMI

- Wi-Fi and the Wi-Fi logo are trademarks or registered trademarks of the Wi-Fi Alliance.
- The N-Mark is a trademark or registered trademark of NFC Forum, Inc. in the United States and in other countries.
- All other trade names mentioned in this manual or the other documentation provided with your Nikon product are the trademarks or registered trademarks of their respective holders.

AVC Patent Portfolio License

This product is licensed under the AVC Patent Portfolio License for the personal and non-commercial use of a consumer to (i) encode video in compliance with the AVC standard ("AVC video") and/or (ii) decode AVC video that was encoded by a consumer engaged in a personal and non-commercial activity and/or was obtained from a video provider licensed to provide AVC video. No license is granted or shall be implied for any other use.

Additional information may be obtained from MPEG LA, L.L.C.
See <http://www.mpegla.com>.

FreeType License (FreeType2)

Portions of this software are copyright © 2012 The FreeType Project (<http://www.freetype.org>). All rights reserved.

MIT License (HarfBuzz)

Portions of this software are copyright © 2016 The HarfBuzz Project (<http://www.freedesktop.org/wiki/Software/HarfBuzz>). All rights reserved.



Series of horizontal dashed lines for writing.

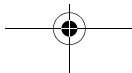
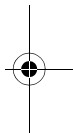
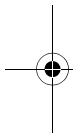



Handwriting practice area consisting of 15 horizontal dashed lines.

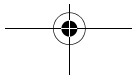
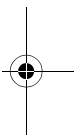



Series of horizontal dashed lines for writing.

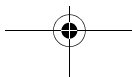
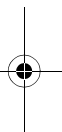



No reproduction in any form of this manual, in whole or in part (except for brief quotation in critical articles or reviews), may be made without written authorization from NIKON CORPORATION.

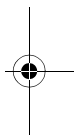

NIKON CORPORATION

© 2016 Nikon Corporation



CT5L01(11)
6MN66611-01



En_01

