



# RADIO TEST REPORT

**Test Report No. : 10812026H-E-R1**

**Applicant** : NIKON CORPORATION  
**Type of Equipment** : Wireless Transmitter  
**Model No.** : N1526  
**FCC ID** : CGJ1152EA  
**Test regulation** : FCC Part 15 Subpart E: 2015  
(DFS test only)  
**Test Result** : Complied

1. This test report shall not be reproduced in full or partial, without the written approval of UL Japan, Inc.
2. The results in this report apply only to the sample tested.
3. This sample tested is in compliance with above regulation.
4. The test results in this report are traceable to the national or international standards.
5. This test report must not be used by the customer to claim product certification, approval, or endorsement by NVLAP, NIST, or any agency of the Federal Government.
6. This test report covers Radio technical requirements. It does not cover administrative issues such as Manual or non-Radio test related Requirements. (if applicable)
7. This report is a revised version of 10812026H-E. 10812026H-E is replaced with this report.

**Date of test:** June 25, 2015

**Representative test engineer:** T. Shimada  
Takumi Shimada  
Engineer  
Consumer Technology Division

**Approved by:** T. Hatakeda  
Takahiro Hatakeda  
Leader  
Consumer Technology Division



NVLAP LAB CODE: 200572-0

This laboratory is accredited by the NVLAP LAB CODE 200572-0, U.S.A. The tests reported herein have been performed in accordance with its terms of accreditation.  
\*As for the range of Accreditation in NVLAP, you may refer to the WEB address,  
[http://japan.ul.com/resources/emc\\_accredited/](http://japan.ul.com/resources/emc_accredited/)

**UL Japan, Inc.**

**Ise EMC Lab.**

4383-326 Asama-cho, Ise-shi, Mie-ken 516-0021 JAPAN

Telephone : +81 596 24 8999

Facsimile : +81 596 24 8124

13-EM-F0429



<b>CONTENTS</b>	<b>PAGE</b>
<b>SECTION 1: Customer information.....</b>	<b>4</b>
<b>SECTION 2: Equipment under test (E.U.T.).....</b>	<b>4</b>
<b>SECTION 3: Scope of Report.....</b>	<b>5</b>
<b>SECTION 4: Test specification, procedures &amp; results.....</b>	<b>5</b>
<b>SECTION 5: Operation of E.U.T. during testing.....</b>	<b>10</b>
<b>SECTION 6: Channel Move Time, Channel Closing Transmission Time.....</b>	<b>16</b>
<b>SECTION 7: Non-Occupancy Period .....</b>	<b>18</b>
<b>APPENDIX 1: Test instruments .....</b>	<b>20</b>
<b>APPENDIX 2: Photographs of test setup .....</b>	<b>21</b>

**SECTION 1: Customer information**

Company Name : NEC Platforms, Ltd.  
Address : 800, Shimomata, Kakegawa-shi, Shizuoka 436-8501, Japan  
Telephone Number : +81-537-22-8276  
Facsimile Number : +81-537-22-8236  
Contact Person : Kouichi Sakurai

\*Remarks:

NIKON CORPORATION designates NEC Platforms, Ltd. as manufacturer of the product (Wireless Transmitter).

**SECTION 2: Equipment under test (E.U.T.)**

**2.1 Identification of E.U.T.**

Type of Equipment : Wireless Transmitter  
Model No. : N1526  
Serial No. : Refer to Clause 4.2  
Rating : DC 5.0 V  
Receipt Date of Sample : June 1, 2015  
Country of Mass-production : Japan  
Condition of EUT : Engineering prototype  
(Not for Sale: This sample is equivalent to mass-produced items.)  
Modification of EUT : No Modification by the test lab

**2.2 Product Description**

Model No: N1526 (referred to as the EUT in this report) is the Wireless Transmitter.

**General Specification**

Clock frequency(ies) in the system : 40 MHz (Crystal), 32.7 kHz (OSC)  
Operating temperature : 0 deg. C to +40 deg. C

**Radio Specification**

Radio Type : Transceiver  
Power Supply (inner) : DC 3.3 V

**Specification of Wireless LAN (IEEE802.11b/g/a/n-20/n-40/11ac-20/11ac-40/11ac-80)**

Type of radio	IEEE802.11b	IEEE802.11g/n (20 M band)	IEEE802.11n (40 M band)	IEEE802.11a/n/ac (20 M band)	IEEE802.11n/ac (40 M band)	IEEE802.11ac (80 M band)
Frequency of operation (MHz)	2412 - 2462	2412 - 2462	2422 - 2452	5180 - 5240 5260 - 5320 * 5745 - 5825	5190 - 5230 5270 - 5310 * 5755 - 5795	5210 5290 * 5775
Type of modulation	DSSS (CCK, DQPSK, DBPSK)	OFDM-CCK (64QAM, 16QAM, QPSK, BPSK)		OFDM (64QAM, 16QAM, QPSK, BPSK, 256QAM(IEEE802.11ac only))		
Channel spacing	5 MHz			20 MHz	40 MHz	80 MHz
Antenna type	Antenna 0: Pattern Antenna Inverted L Type Antenna 1: Pattern Antenna Inverted L Type					
Antenna Gain	2.4GHz: 1 dBi 5GHz: 1 dBi					
Directional Antenna Gain	2.4 GHz: 4.01 dBi 5 GHz: 4.01 dBi					

\* This test report applies to Wireless LAN (5 GHz Band [5260-5320 MHz , 5270-5310 MHz, and 5290 MHz]).

**UL Japan, Inc.  
Ise EMC Lab.**

4383-326 Asama-cho, Ise-shi, Mie-ken 516-0021 JAPAN  
Telephone : +81 596 24 8999  
Facsimile : +81 596 24 8124

### **SECTION 3: Scope of Report**

This report only covers DFS requirement, as specified by the following referenced procedures.

### **SECTION 4: Test specification, procedures & results**

#### **4.1 Test Specification**

Test Specification	:	FCC Part 15 Subpart E: 2015, final revised on November 23, 2015 *Some parts are effective on and after December 17, 2015 or December 23, 2015. The revision does not affect the test specification applied to the EUT.
Title	:	FCC 47CFR Part15 Radio Frequency Device Subpart E Unlicensed National Information Infrastructure Devices Section 15.407 General technical requirements
Test Specification	:	KDB905462 D02 UNII DFS Compliance Procedures New Rules v01r02
Title	:	COMPLIANCE MEASUREMENT PROCEDURES FOR UNLICENSED- NATIONAL INFORMATION INFRASTRUCTURE DEVICES OPERATING IN THE 5250-5350MHz AND 5470-5725MHz BANDS INCORPORATING DYNAMIC FREQUENCY SELECTION
Test Specification	:	KDB905462 D03 Client Without DFS New Rules v01r01
Title	:	U-NII CLIENT DEVICES WITHOUT RADAR DETECTION CAPABILITY
Test Specification	:	KDB905462 D04 Operational Modes for DFS Testing New Rules v01
Title	:	OPERATIONAL MODES SUGGESTED FOR DFS TESTING

#### **FCC 15.31 (e)**

This EUT provides stable voltage (DC 3.3 V) constantly to RF Part regardless of input voltage. Therefore, this EUT complies with the requirement.

#### **FCC Part 15.203 Antenna requirement**

It is impossible for end users to replace the antenna, because the antenna is mounted inside of the EUT. Therefore, the equipment complies with the antenna requirement of Section 15.203.

---

**UL Japan, Inc.**

**Ise EMC Lab.**

4383-326 Asama-cho, Ise-shi, Mie-ken 516-0021 JAPAN

Telephone : +81 596 24 8999

Facsimile : +81 596 24 8124

## 4.2 Procedures and results

**Table 1: Applicability of DFS Requirements**

Requirement	Operating Mode	Test Procedures & Limits	Deviation	Results
	Client without Radar Detection			
U-NII Detection Bandwidth	Not required	KDB905462 D02 UNII DFS Compliance Procedures New Rules v01r02	N/A	N/A
Initial Channel Availability Check Time	Not required	FCC15.407 (h)	N/A	N/A
		KDB905462 D02 UNII DFS Compliance Procedures New Rules v01r02		
		RSS-247 6.3		
Radar Burst at the Beginning of the Channel Availability Check Time	Not required	FCC15.407 (h)	N/A	N/A
		KDB905462 D02 UNII DFS Compliance Procedures New Rules v01r02		
		RSS-247 6.3		
Radar Burst at the End of the Channel Availability Check Time	Not required	FCC15.407 (h)	N/A	N/A
		KDB905462 D02 UNII DFS Compliance Procedures New Rules v01r02		
		RSS-247 6.3		
In-Service Monitoring for Channel Move Time, Channel Closing Transmission Time	Yes	FCC15.407 (h)	N/A	Complied
		KDB905462 D02 UNII DFS Compliance Procedures New Rules v01r02		
		RSS-247 6.3		
In-Service Monitoring for Non-Occupancy period	Yes *	FCC15.407 (h)	N/A	Complied
		KDB905462 D02 UNII DFS Compliance Procedures New Rules v01r02		
		RSS-247 6.3		
Statistical Performance Check	Not required	FCC15.407 (h)	N/A	N/A
		KDB905462 D02 UNII DFS Compliance Procedures New Rules v01r02		

Note: UL Japan, Inc.'s EMI Work Procedures No. 13-EM-W0422.

\*Although this test was not required in FCC, KDB 905462 D02, it was performed as additional test.

**Table 2 DFS Detection Thresholds for Master Devices and Client Devices With Radar Detection**

Maximum Transmit Power	Value (See Notes 1,2, and 3)
≥ 200 milliwatt	-64 dBm
< 200 milliwatt and power spectral density < 10dBm/MHz	-62 dBm
< 200 milliwatt that do not meet the power spectral density requirement	-64 dBm
<p>Note 1: This is the level at the input of the receiver assuming a 0 dBi receive antenna.</p> <p>Note 2: Throughout these test procedures an additional 1 dB has been added to the amplitude of the test transmission waveforms to account for variations in measurement equipment. This will ensure that the test signal is at or above the detection threshold level to trigger a DFS response.</p> <p>Note 3: EIRP is based on the highest antenna gain. For MIMO devices refer to KDB Publication 662911 D01.</p>	

**Table 3 DFS Response Requirement Values**

Parameter	Value
Non-occupancy period	Minimum 30 minutes
Channel Availability Check Time	60 seconds
Channel Move Time	10 seconds See Note 1
Channel Closing Transmission Time	200 milliseconds + an aggregate of 60 milliseconds over remaining 10 second period. See Notes 1 and 2
U-NII Detection Bandwidth	Minimum 100% of the U-NII 99% transmission power bandwidth See Note 3
<p><b>Note 1:</b> Channel Move Time and the Channel Closing Transmission Time should be performed with Radar Type 0. The measurement timing begins at the end of the Radar Type 0 burst.</p> <p><b>Note 2:</b> The Channel Closing Transmission Time is comprised of 200 milliseconds starting at the beginning of the Channel Move Time plus any additional intermittent control signals required to facilitate a Channel move (an aggregate of 60 milliseconds) during the remainder of the 10 second period. The aggregate duration of control signal will not count quiet periods in between transmissions.</p> <p><b>Note 3:</b> During the U-NII Detection Bandwidth detection test, radar type 0 should be used. For each frequency step the minimum percentage of detection is 90 percent. Measurements are performed with no data traffic.</p>	

**Table 4 Short Pulse Radar Test Waveform**

Radar Type	Pulse Width (μsec)	PRI (μsec)	Number of Pulses	Minimum Percentage of Successful Detection	Minimum Number of Trials
0	1	1428	18	See Note 1	See Note 1
1	1	Test A: 15 unique PRI values randomly selected from the list of 23 PRI values in Table 5a	Roundup $\{(1/360)* (19*10^6/PRI_{\text{usec}})\}$	60%	30
		Test B: 15 unique PRI values randomly selected within the range of 518-3066 μsec, with a minimum increment of 1 μsec, excluding PRI values selected in Test A			
2	1-5	150-230	23-29	60%	30
3	6-10	200-500	16-18	60%	30
4	11-20	200-500	12-16	60%	30
Aggregate (Rader Types 1-4)				80%	120
Note 1: Short Pulse Radar Type 0 should be used for the detection bandwidth test, channel move time, and channel closing time tests.					

**Table 5 Long Pulse Radar Test Waveform**

Radar Type	Pulse Width (μsec)	Chip Width (MHz)	PRI (μsec)	Number of Pulses per Burst	Number of Burst	Minimum Percentage of Successful Detection	Minimum Number of Trials
5	50-100	5-20	1000-2000	1-3	8-20	80%	30

**Table 6 Frequency Hopping Radar Test Waveform**

Radar Type	Pulse Width (μsec)	PRI (μsec)	Pulse per Hop (kHz)	Hopping Rate (kHz)	Hopping Sequence Length (msec)	Minimum Percentage of Successful Detection	Minimum Number of Trials
6	1	333	9	0.333	300	70%	30



### 4.3 Test Location

UL Japan, Inc. Ise EMC Lab. \*NVLAP Lab. code: 200572-0  
 4383-326 Asama-cho, Ise-shi, Mie-ken 516-0021 JAPAN  
 Telephone : +81 596 24 8999 Facsimile : +81 596 24 8124

	IC Registration Number	Width x Depth x Height (m)	Size of reference ground plane (m) / horizontal conducting plane	Other rooms
No.1 semi-anechoic chamber	2973C-1	19.2 x 11.2 x 7.7m	7.0 x 6.0m	No.1 Power source room
No.2 semi-anechoic chamber	2973C-2	7.5 x 5.8 x 5.2m	4.0 x 4.0m	-
No.3 semi-anechoic chamber	2973C-3	12.0 x 8.5 x 5.9m	6.8 x 5.75m	No.3 Preparation room
No.3 shielded room	-	4.0 x 6.0 x 2.7m	N/A	-
No.4 semi-anechoic chamber	2973C-4	12.0 x 8.5 x 5.9m	6.8 x 5.75m	No.4 Preparation room
No.4 shielded room	-	4.0 x 6.0 x 2.7m	N/A	-
No.5 semi-anechoic chamber	-	6.0 x 6.0 x 3.9m	6.0 x 6.0m	-
No.6 shielded room	-	4.0 x 4.5 x 2.7m	4.0 x 4.5 m	-
No.6 measurement room	-	4.75 x 5.4 x 3.0m	4.75 x 4.15 m	-
No.7 shielded room	-	4.7 x 7.5 x 2.7m	4.7 x 7.5m	-
No.8 measurement room	-	3.1 x 5.0 x 2.7m	N/A	-
No.9 measurement room	-	8.0 x 4.6 x 2.8m	2.4 x 2.4m	-
No.11 measurement room	-	6.2 x 4.7 x 3.0m	4.8 x 4.6m	-

\* Size of vertical conducting plane (for Conducted Emission test) : 2.0 x 2.0m for No.1, No.2, No.3, and No.4 semi-anechoic chambers and No.3 and No.4 shielded rooms.

### 4.4 Uncertainty

The following uncertainties have been calculated to provide a confidence level of 95 % using a coverage factor  $k = 2$ .  
 Time Measurement uncertainty for this test was: ( $\pm$ ) 0.012 %

### 4.5 Data of DFS test, Test instruments of DFS, Test set up

Refer to APPENDIX.

## **SECTION 5: Operation of E.U.T. during testing**

### **5.1 Operating Modes**

For FCC the EUT operates over the 5260-5320MHz, 5270-5310MHz and 5290MHz ranges.

The EUT has the Client mode without Radar Detection.

The highest power level is 17.31dBm EIRP in the 5260-5320MHz band.

Power level(EIRP) of the EUT[dBm]

Output Power (Max)		
20Mband	40Mband	80Mband
17.30	17.31	14.14

Power spectral density level of the EUT[dBm/MHz]

Output Power (Max)		
20Mband	40Mband	80Mband
2.83	-0.93	-6.17

\*Refer to 10812026H-C-R1, FCC Part 15E (FCC 15.407) report for other parts than DFS.

The channel-loading of approximately 17% or greater was used for testing, and its test data was transferred from the Master Device to the Client Device for all test configurations.

The EUT utilizes the 802.11a/n/ac architecture, with a 20MHz, 40MHz and 80MHz channel bandwidth.

The FCC ID for the Master Device used with EUT for DFS testing is LDK102087.

The rated output power of the Master unit is >200mW(23dBm). Therefore the required interference threshold level is -64 dBm. After correction for antenna gain and procedural adjustments, the required conducted threshold at the antenna port is  $-64 + 1 + 0 = -63.0$  dBm (threshold level + additional 1dB + antenna gain).

It is impossible for users to change DFS control, because the DFS function is written on the firmware and users cannot access it.

The EUT was set by the software as follows:

Software name & version: iperf Version: 2.0.5 (08.Jul 2010)

---

**UL Japan, Inc.**

**Ise EMC Lab.**

4383-326 Asama-cho, Ise-shi, Mie-ken 516-0021 JAPAN

Telephone : +81 596 24 8999

Facsimile : +81 596 24 8124



### 5.3 Test and Measurement System

#### SYSTEM OVERVIEW

The measurement system is based on a conducted test method.

The software selects waveform parameters from within the bounds of the signal type on a random basis using uniform distribution. The short pulse types 1, 2, 3, and 4, the long pulse type 5, and the frequency hopping type 6 parameters are randomized at run-time.

The signal monitoring equipment consists of a spectrum analyzer with the capacity to display 8001 bins on the horizontal axis. A time-domain resolution of 2 msec/bin is achievable with a 16 second sweep time, meeting the 10 seconds short pulse reporting criteria. The aggregate ON time is calculated by multiplying the number of bins above a threshold during a particular observation period by the dwell time per bin, with the analyzer set to peak detection.

#### FREQUENCY HOPPING RADAR WAVEFORM GENERATING SUBSYSTEM

The first 100 frequencies are selected out of the hopping sequence of the randomized 475 hop frequencies.

Only a *Burst* that has the frequency falling within the receiver bandwidth of the tested U-NII device is selected among those frequencies. (Frequency-domain simulation). The radar waveform generated at the start time of the selected *Burst* (Time-domain simulation) is download to the Signal Generator.

If all of the randomly selected 100 frequencies do not fall within the receiver bandwidth of the U-NII device, the radar waveform is not used for the test.

---

**UL Japan, Inc.**

**Ise EMC Lab.**

4383-326 Asama-cho, Ise-shi, Mie-ken 516-0021 JAPAN

Telephone : +81 596 24 8999

Facsimile : +81 596 24 8124

**CONDUCTED METHODS SYSTEM BLOCK DIAGRAM**

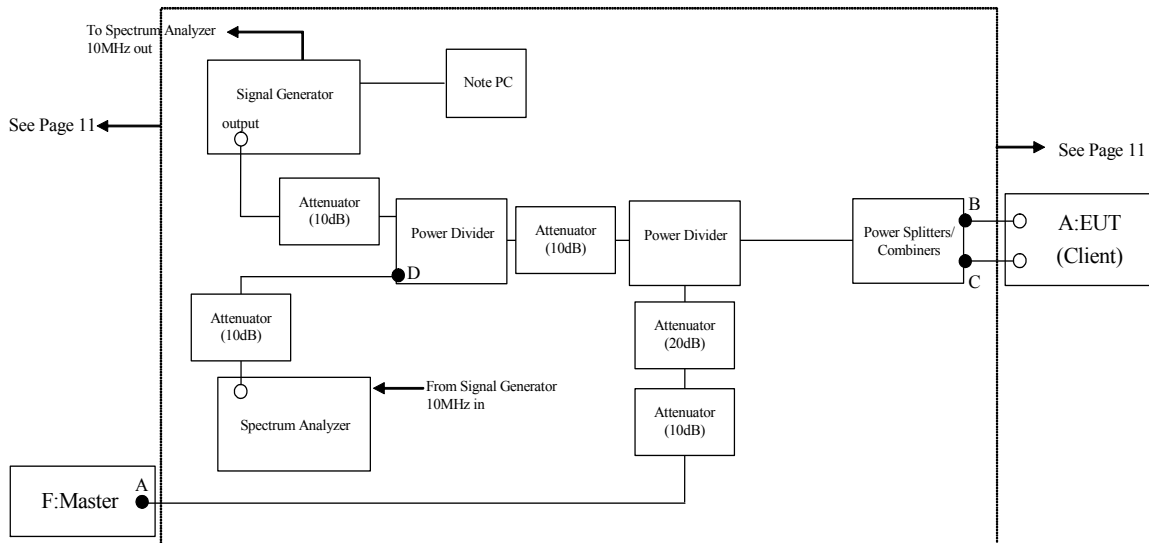

**MEASUREMENT SYSTEM FREQUENCY REFERENCE**

Lock the signal generator and the spectrum analyzer to the same reference sources as follows: Connect the 10MHz OUT on the signal generator to the 10MHz IN on the spectrum analyzer and set the spectrum analyzer 10MHz In to On.

## **SYSTEM CALIBRATION**

**Step 1:** Set the system as shown in Figure 3 of KDB905462 D02 7.2.2.

**Step 2:** Adjust each attenuator to fulfill the following three conditions:

- WLAN can be communicated, and
- Rader detection threshold level is bigger than Client Device traffic level on the spectrum analyzer, and
- Master Device traffic level is not displayed on the spectrum analyzer.

**Step 3:** Terminate 50 ohm at B, C and D points, and connect the spectrum analyzer to the point A. (See the figure on page 13)

At the point A, adjust the signal generator and spectrum analyzer to the center frequency of the channel to be measured.

Download the applicable radar waveforms to the signal generator. Select the radar waveform, trigger a burst manually and measure the amplitude on the spectrum analyzer. Readjust the amplitude of the signal generator as required so that the peak level of the waveform is at a displayed level equal to the required or desired interference detection threshold.

Separate signal generator amplitude settings are determined as required for each radar type.

**Step 4:** Without changing any of the instrument settings, restore the system setting to Step 2 and adjust the Reference Level Offset of the spectrum analyzer to the level at Step 3.

By taking the above steps 1 to 4, the spectrum analyzer displays the level of the signal generator as received at the antenna ports of the Master Device.

See Clause 5.4 for Plots of Noise, Rader Waveforms, and WLAN signals.

---

**UL Japan, Inc.**

**Ise EMC Lab.**

4383-326 Asama-cho, Ise-shi, Mie-ken 516-0021 JAPAN

Telephone : +81 596 24 8999

Facsimile : +81 596 24 8124

5.4 Plots of Noise, Rader Waveforms, and WLAN signals

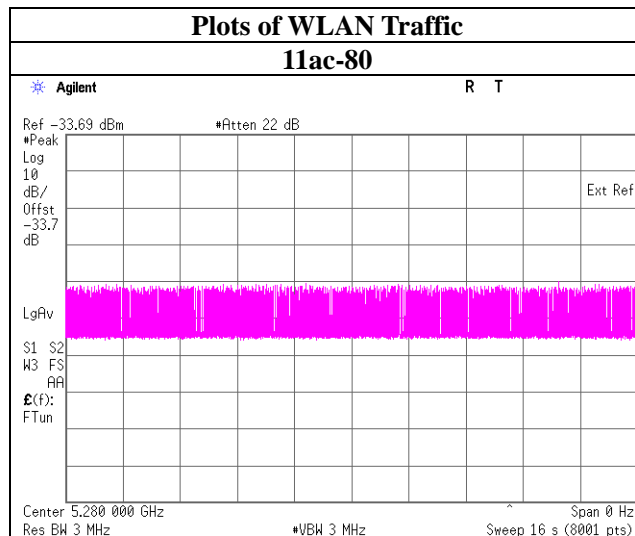
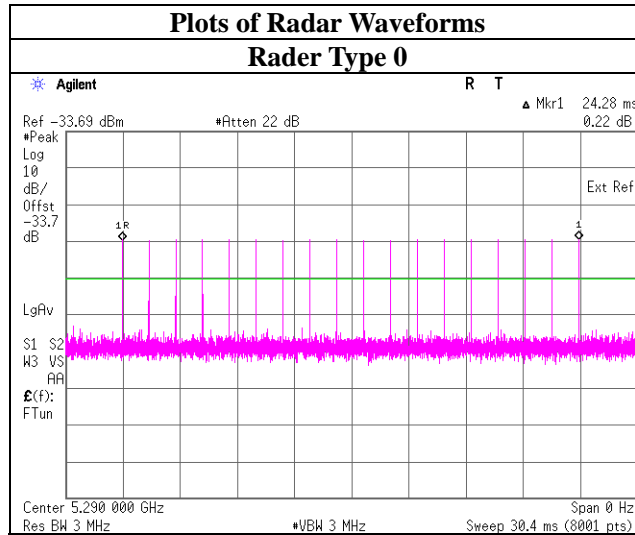
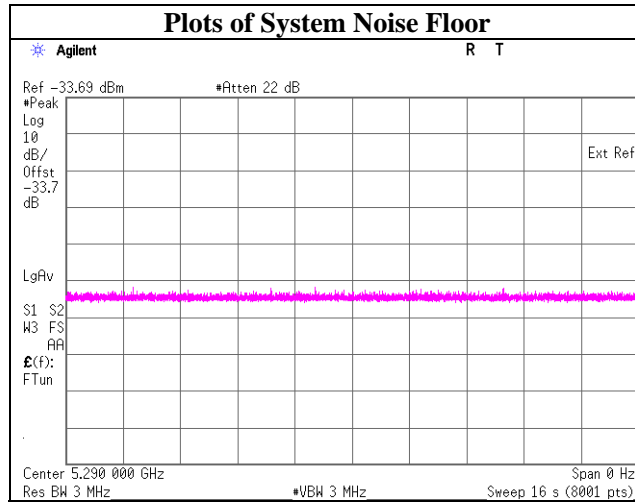

## **SECTION 6: Channel Move Time, Channel Closing Transmission Time**

### **6.1 Operating environment**

Test place Ise EMC Lab.No.7 shielded room  
Date 06/25/2015  
Temperature/ Humidity 23deg. C / 62% RH  
Engineer Takumi Shimada  
Mode 11ac-80

### **6.2 Test Procedure**

Transmit the data from the Master Device to the Client Device on the test Channel for the entire period of the test. The Radar Waveform generator sends a Burst of pulses for one of the Radar Types 0 at levels defined on the Operating Channel. An additional 1 dB is added to the radar test signal to ensure it is at or above the DFS Detection Threshold, accounting for equipment variations/errors.

Observe the transmissions of the EUT at the end of the radar Burst on the Operating Channel for duration greater than 10 seconds.

### **6.3 Test data**

#### **11ac-80**

Test Item	Unit	Measurement Time	Limit	Results
Channel Move Time *1)	[sec]	0.084	10.000	Pass
Channel Closing Transmission Time *2)	[msec]	0	60	Pass

\*1) Channel Move Time is calculated as follows:

(Channel Move Time) = (End of Transmission) - (End of Burst) = 1.8-1.716

\*2) Channel Closing Transmission Time is calculated from (End of Burst + 200msec) to (End of Burst + 10sec )

(Channel Closing Transmission Time) = (Number of analyzer bins showing transmission) × (dwell time per bin)  
= 0 × 2[msec]

---

**UL Japan, Inc.**

**Ise EMC Lab.**

4383-326 Asama-cho, Ise-shi, Mie-ken 516-0021 JAPAN

Telephone : +81 596 24 8999

Facsimile : +81 596 24 8124



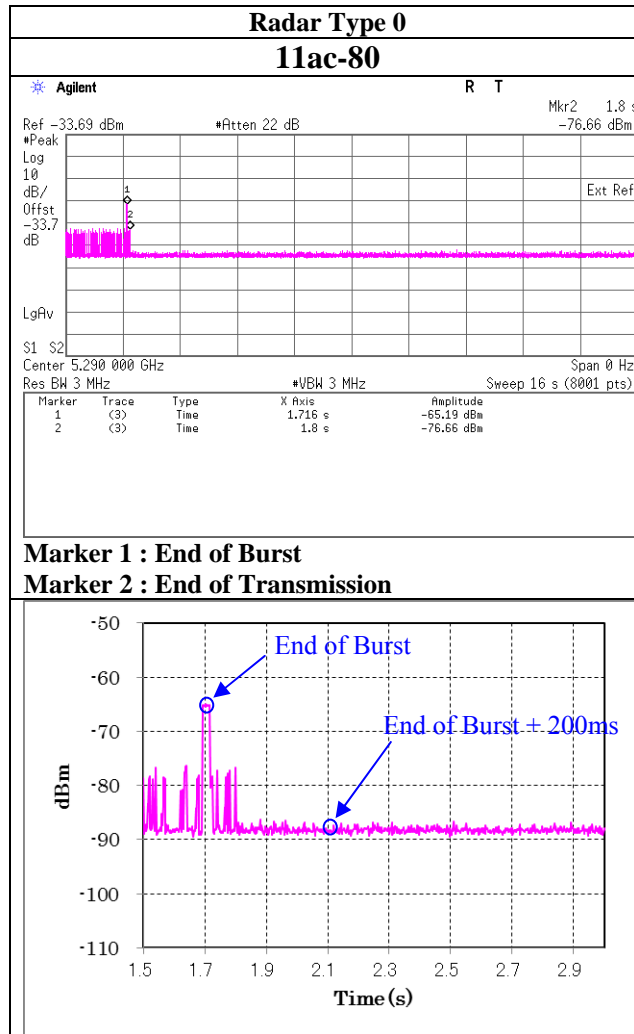

**6.4 Test result**

Test result: Pass

## **SECTION 7: Non-Occupancy Period**

### **7.1 Operating environment**

Test place	Ise EMC Lab. No.7 shielded room
Date	06/25/2015
Temperature/ Humidity	23deg. C / 62% RH
Engineer	Takumi Shimada
Mode	11ac-80

### **7.2 Test Procedure**

The following two tests are performed:

- 1). Transmit the data from the Master Device to the Client Device on the test Channel for the entire period of the test. The Radar Waveform generator sends a Burst of pulses for Radar Types 0 at levels defined on the Operating Channel. An additional 1 dB is added to the radar test signal to ensure it is at or above the DFS Detection Threshold, accounting for equipment variations/errors.  
Observe the transmissions of the EUT after the Channel Move Time on the Operating Channel for duration greater than 30 minutes.
- 2). Transmit the data from the Master Device to the Client Device on the test Channel for the entire period of the test. Observe the transmissions of the EUT on the Operating Channel for duration greater than 30 minutes after the Master Device is shut off.

---

**UL Japan, Inc.**

**Ise EMC Lab.**

4383-326 Asama-cho, Ise-shi, Mie-ken 516-0021 JAPAN

Telephone : +81 596 24 8999

Facsimile : +81 596 24 8124

7.3 Test data

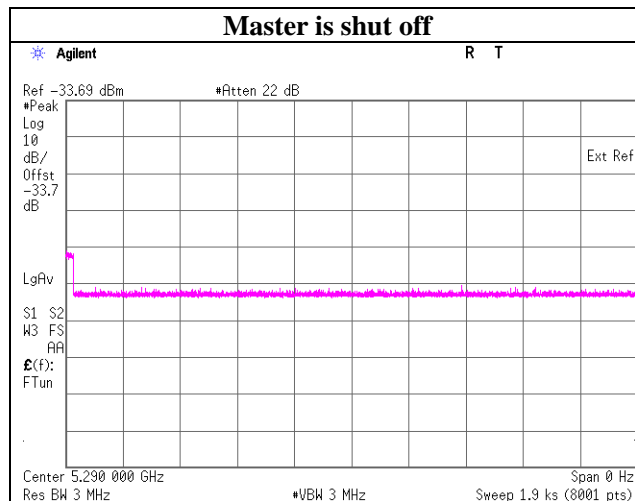
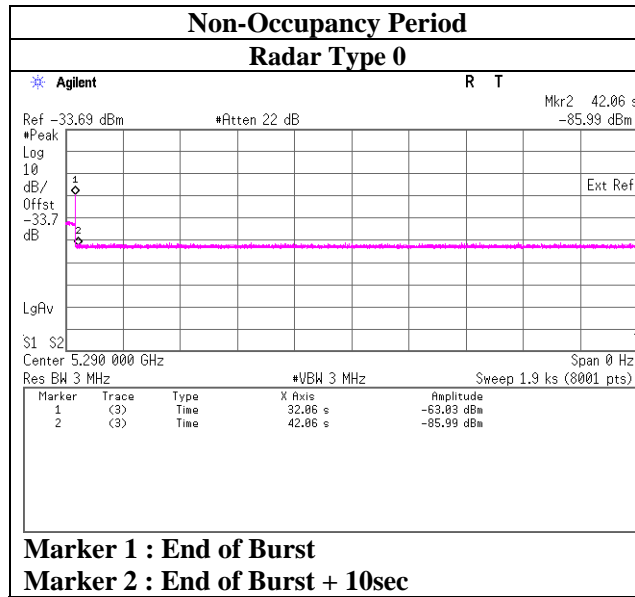

7.4 Test result

Test result: Pass

## **APPENDIX 1: Test instruments**

### **EMI Test Equipment**

Control No.	Instrument	Manufacturer	Model No	Serial No	Test Item	Calibration Date * Interval(month)
MSA-04	Spectrum Analyzer	Agilent	E4448A	US44300523	DFS	2014/11/12 * 12
EST-48 *1)	Signal Generator	Agilent	E4438C	MY45090353	DFS	2014/12/19 * 12
MPD-01	PowerDivider DC to 26.5GHz	Agilent	11636B	52258	DFS	2015/03/10 * 12
MPSC-04	Power Splitters/Combiners	Mini-Circuit	ZFSC-2-10G	0326	DFS	2014/09/26 * 12
MPSC-07	Power Splitters/Combiners	Pasternack Enterprises	ZFRSC-123-S+	ZFRSC-123- 00232	DFS	Pre Check
MAT-20	Attenuator(10dB)(above 1GHz)	HIROSE ELECTRIC CO.,LTD.	AT-110	-	DFS	2015/01/08 * 12
MAT-56	Attenuator(10dB)	Suhner	6810.19.A	-	DFS	2015/01/08 * 12
MAT-57	Attenuator(10dB)	Suhner	6810.19.A	-	DFS	2015/01/08 * 12
MAT-58	Attenuator(10dB)	Suhner	6810.19.A	-	DFS	2015/01/09 * 12
MAT-59	Attenuator(20dB)	Suhner	6820.19.A	-	DFS	Pre Check
MCC-183	Microwave Cable	Junkosha	MMX221- 00500DMSDMS	1502S310	DFS	Pre Check
MCC-172	Microwave Cable	Junkosha	MWX221	1409S495	DFS	2015/03/04 * 12
MCC-174	Microwave Cable	Junkosha	MWX221	1409S497	DFS	2015/03/04 * 12
COTS-MDFS- 01	Signal Studio Software for DFS	Agilent	N7620A-101	5010-7739	DFS	-
COTS-MDFS- 02	Radar Generating Software for DFS	Agilent	-	-	DFS	-
MOS-34	Thermo-Hygrometer	Custom	CTH-201	3401	DFS	2015/01/13 * 12

**\*1) Signal generator is only used to generate radar test signal, and the wave form is confirmed with spectrum analyzer every time before the test.**

**The expiration date of the calibration is the end of the expired month.**

**All equipment is calibrated with valid calibrations. Each measurement data is traceable to the national or international standards.**

**As for some calibrations performed after the tested dates, those test equipment have been controlled by means of an unbroken chains of calibrations.**

**DFS: Dynamic Frequency Selection**

**UL Japan, Inc.**

**Ise EMC Lab.**

4383-326 Asama-cho, Ise-shi, Mie-ken 516-0021 JAPAN

Telephone : +81 596 24 8999

Facsimile : +81 596 24 8124