



**TEST REPORT CONCERNING THE COMPLIANCE OF A
134 KHZ INDUCTIVE PROXIMITY TAG READER,
BRAND NEDAP, MODEL VP1007 WITH VP6012
WITH 47 CFR PART 15 (JULY 10, 2008).**

FCC listed : 90828
Industry Canada : 2932G-1
VCCI Registered : R-1518, C-1598
R&TTE, LVD, EMC Notified Body : 1856

**TÜV Rheinland EPS B.V.
P.O. Box 15
9822 ZG Niekerk (NL)
Smidshornerweg 18
9822 TL Niekerk (NL)**

Telephone: +31 594 505005
Telefax: +31 594 504804

E-mail: info@tuv-eps.com
Web: www.tuv-eps.com

MEASUREMENT/TECHNICAL REPORT

Nedap N.V.
Model: VP1007

FCC ID: CGDVELOS4

April 22, 2009

This report concerns:		Original grant/certification	Class 2 change	Verification
Equipment type:		134 kHz Inductive proximity tag reader		
Deferred grant requested per 47 CFR 0.457(d)(1)(ii) ?		Yes	No	n.a.
Report prepared by:	Name	: Richard van der Meer		
	Company name	: TÜV Rheinland EPS B.V.		
	Address	: Smidshornerweg 18		
	Postal code/city	: 9822 TL Niekerk		
	Mailing address	: P.O. Box 15		
	Postal code/city	: 9822 ZG Niekerk		
	Country	: The Netherlands		
	Telephone number	: + 31 594 505 005		
	Telefax number	: + 31 594 504 804		
	E-mail	: info@tuv-eps.com		

The data taken for this test and report herein was done in accordance with 47 CFR Part 15 (july 10, 2008) the measurement procedures of ANSI C63.4-2003. TÜV Rheinland EPS B.V. at Niekerk, The Netherlands, certifies that the data is accurate and contains a true representation of the emission profile of the Equipment Under Test (EUT) on the date of the test as noted in the test report. I have reviewed the test report and find it to be an accurate description of the test(s) performed and the EUT so tested.

Date: April 22, 2009

Signature:



O. Hoekstra
Senior Engineer Telecom TÜV Rheinland EPS B.V.

Description of test item

Test item : Inductive proximity tag reader, operating on 134.2 kHz, brand Nedap
Manufacturer : N.V. Nederlandsche Apparatenfabriek "Nedap"
Brand : Nedap
Model(s) : VP1007
Serial number(s) : X 126 0004
Revision : n.a.
Receipt date : January 27, 2009

Applicant information

Applicant's representative : Mr. J. Hulshof
Company : N.V. Nederlandsche Apparatenfabriek "Nedap"
Address : Parallelweg 2
Postal code : 7141 DC
City : Groenlo
Country : The Netherlands
Telephone number : +31 544 471 444
Telefax number : +31 544 466 839

Test(s) performed

Location : Niekerk
Test(s) started : January 28, 2009
Test(s) completed : February 03, 2009
Purpose of test(s) : Equipment Authorization (Original grant/certification)

Test specification(s) : 47 CFR Part 15 (July 10, 2008)

Test engineers : R. van der Meer



Report written by : R. van der Meer



Report date : April 22, 2009

This report is in conformity with NEN-EN-ISO/IEC 17025: 2005
This report shall not be reproduced, except in full, without the written permission of TÜV Rheinland EPS B.V.
The test results relate only to the item(s) tested.

Table of contents

1	General information.....	5
1.1	Product description.....	5
1.1.1	Introduction.....	5
1.2	Related submittal(s) and/or Grant(s).....	5
1.2.1	General.....	5
1.3	Tested system details.....	5
1.3.1	Description of input and output ports.....	8
1.4	Test methodology.....	9
1.5	Test facility.....	9
1.6	Test conditions.....	9
2	System test configuration.....	10
2.1	Justification.....	10
2.2	EUT mode of operation.....	10
2.3	Special accessories.....	10
2.4	Equipment modifications.....	10
2.5	Product Labelling.....	10
2.6	Block diagram of the EUT.....	10
2.7	Schematics of the EUT.....	10
2.8	Part list of the EUT.....	10
3	Radiated emission data.....	11
3.1	Radiated field strength measurements (30 MHz – 1 GHz, E-field).....	11
3.2	Radiated field strength measurements (frequency range of 0.009-30 MHz, H-field).....	12
4	Carrier stability under special conditions.....	13
4.1	Frequency stability in accordance with 47 CFR Part 15, section 15.31:.....	13
4.1.1	At 85% and 115% of rated voltage supply level.....	13
5	Conducted emission data.....	14
5.1	Conducted emission data of the EUT.....	14
6	List of utilized test equipment.....	15

1 General information.

1.1 Product description.

1.1.1 Introduction.

VP1007 is a module for animals RF detection at a farm. It consists of a long wave transmitter and receiver and has some inputs/outputs for controlling/reading actuators/sensors. The transmitter / receiver is made to read passive tags in or carried by animals. It has one transmitter and two receivers. The first one reads the full duplex tags, the second one the half duplex ones. Full duplex tags transmit the label code with AM modulation at the same frequency as the transmitter, in this case 134.2 kHz. The half duplex tags send their information with help of FSK modulation in the 118 – 140 kHz band.

The content of this report and measurement results have not been changed other than the way of presenting the data.

1.2 Related submittal(s) and/or Grant(s).

1.2.1 General.

This test report supports the original grant/certification in equipment authorization files under FCC ID: CGDVELOS4.

1.3 Tested system details.

Details and an overview of the system and all of its components, as it has been tested, may be found below.

EUT1	:	Inductive proximity card reader operating at 134.2 kHz (ISO Reader IO & COM Velos)
Manufacturer	:	N.V. Nederlandsche Apparatenfabriek "Nedap"
Brand	:	Nedap
Models	:	VP1007
Serial number	:	X126 0002
Voltage input rating	:	25vdc
Voltage output rating	:	25vdc
Remark	:	Tested with EUT10 (Solid mimi antenna)
EUT2	:	Inductive proximity card reader operating at 134.2 kHz (ISO Reader Solid (can))
Manufacturer	:	N.V. Nederlandsche Apparatenfabriek "Nedap"
Brand	:	Nedap
Model	:	VP1101
Serial number	:	X126 0002
Voltage input rating	:	25vdc
Voltage output rating	:	25vdc
Current input rating	:	not provided
Antenna	:	Internal
Remarks	:	--
EUT3	:	ISO Reader IO & COM Velos
Manufacturer	:	N.V. Nederlandsche Apparatenfabriek "Nedap"
Brand	:	Nedap
Models	:	VP1007
Serial number	:	X126 0004
Voltage input rating	:	25vdc
Voltage output rating	:	25vdc
Remark	:	Not used as a transmitter, instead used for I/O

EUT4	:	V-PU
Manufacturer	:	N.V. Nederlandsche Apparatenfabriek "Nedap"
Brand	:	Nedap
Models	:	VP8001
Serial number	:	W820B 0003
Voltage input rating	:	25vdc
Voltage output rating	:	25vdc
Remark	:	---
EUT5	:	VP-VC4
Manufacturer	:	N.V. Nederlandsche Apparatenfabriek "Nedap"
Brand	:	Nedap
Models	:	VP3104
Serial number	:	X126 0004
Voltage input rating	:	25vdc
Voltage output rating	:	25vdc
Remark	:	---
EUT6	:	Power supply
Manufacturer	:	N.V. Nederlandsche Apparatenfabriek "Nedap"
Brand	:	Nedap
Models	:	VP2001
Serial number	:	W926 0010
Voltage input rating	:	AC100.. 240vac.
Voltage output rating	:	25vdc
Remark	:	---
EUT7	:	HDX – FDX
Manufacturer	:	N.V. Nederlandsche Apparatenfabriek "Nedap"
Brand	:	Nedap
Models	:	VP1001
Serial number	:	---
Voltage input rating	:	25vdc
Voltage output rating	:	25vdc
Remark	:	FCC ID: CGDVELOS1
EUT8	:	Motormodule
Manufacturer	:	N.V. Nederlandsche Apparatenfabriek "Nedap"
Brand	:	Nedap
Models	:	VP3001
Serial number	:	V719 0007
Voltage input rating	:	25vdc
Voltage output rating	:	25vdc
Remark	:	---
EUT9	:	Antenna 120 x 50
Manufacturer	:	N.V. Nederlandsche Apparatenfabriek "Nedap"
Brand	:	Nedap
Models	:	VP6050
Serial number	:	---
Voltage input rating	:	---
Voltage output rating	:	---
Remark	:	Only used on VP1001 FCCID: CGDVELOS1

EUT10	:	V – Sense velos
Manufacturer	:	N.V. Nederlandsche Apparatenfabriek "Nedap"
Brand	:	Nedap
Models	:	VP6012
Serial number	:	V710A 0006
Voltage input rating	:	---
Voltage output rating	:	---
Remark	:	Solid mimi antenna for detection Power ID tags, used on EUT1
AUX	:	MPC
Manufacturer	:	N.V. Nederlandsche Apparatenfabriek "Nedap"
Brand	:	Westfallia
Models	:	VC SMPS
Serial number	:	P808 0006
Voltage input rating	:	100-230vac
Voltage output rating	:	---
Remark	:	only used for monitoring during testing.

1.3.1 Description of input and output ports.

Number	Terminal	From	To	Remarks
1	Mains	Mains	Power supply	Shielded cable
2	25vdc	VP8001-2 (VPU)	VP1001	Shielded cable
3	25vdc	VP1001	VP1007	Shielded cable
4	25vdc	VP1007	VP1007	Shielded cable
5	25vdc	VP3001	VP3104	Shielded cable
6	antenna	VP1007	V-Sense velos	Shielded cable
7	RS485	VP1007	VP1007	Shielded cable
8	CAN	VP1101	VP8001	Shielded cable
9	25vdc	VP2001	VP8001-2 (VPU)	Shielded cable
10	25vdc	VP1007	VP3001	Shielded cable

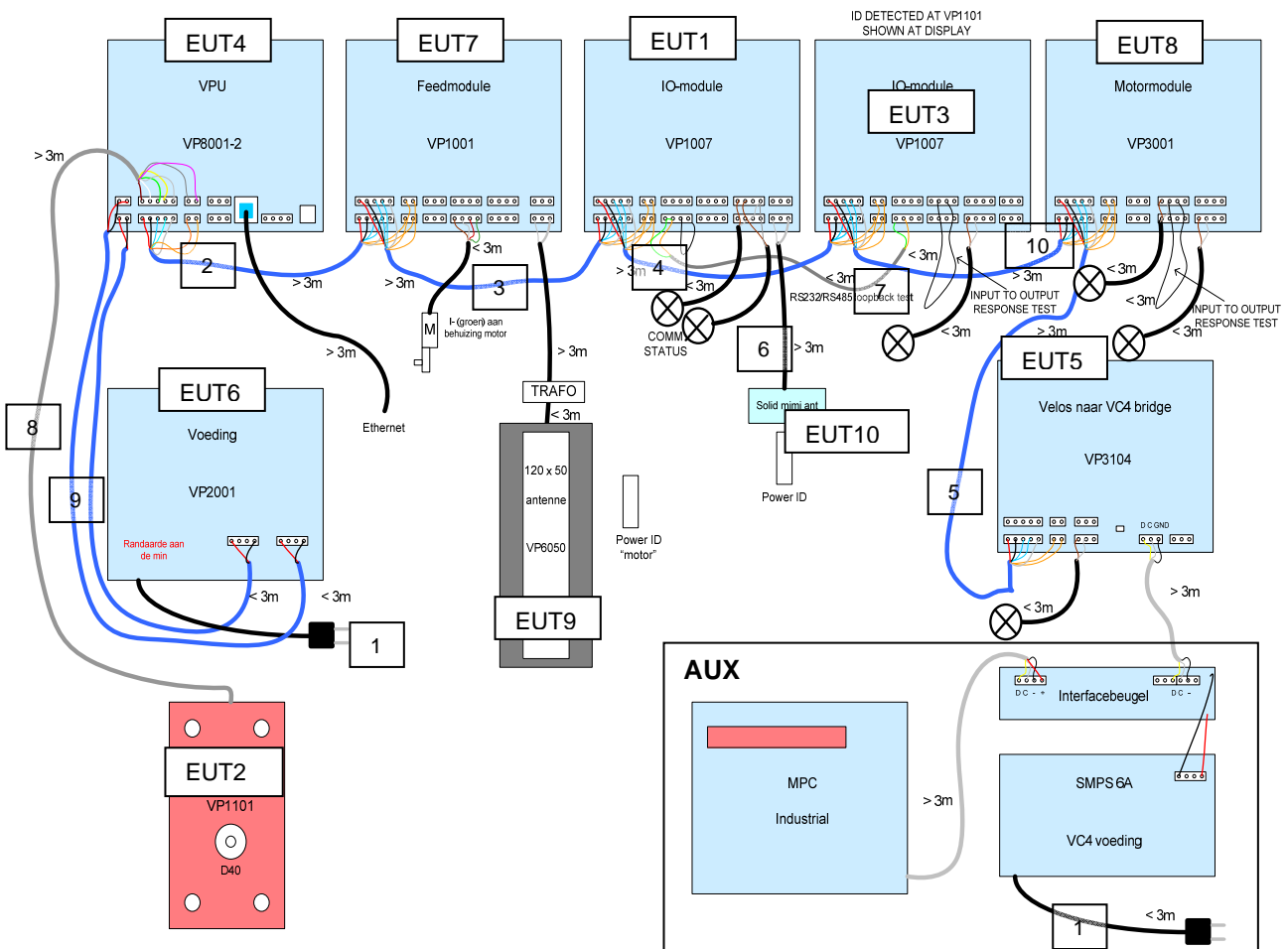

Figure 1. Basic set-up

1.4 Test methodology.

The test methodology used is based on the requirements of 47 CFR Part 15 (july 10, 2008), sections 15.31, 15.207 and 15.209.

The test methods, which have been used, are based on ANSI C63.4: 2003.

Radiated emission tests above 30 MHz were performed at a measurement distance of 3 meters.

Radiated emission tests below 30 MHz were performed at a measurement distance of 3 meters and 10 meters. To calculate the field strength level from these results to the appropriate distance at which the limit is specified, the calculation on Appendix 1 is used.

The receivers are switching automatically to the right bandwidth in accordance with CISPR 16. This is implemented in the receiver. The antenna factors are programmed in the test receiver. The receiver automatically calculates the appropriate correction factor for the utilized antenna and also the appropriate antenna factor for the cable loss. The total correction is automatically added to the measured value.

1.5 Test facility.

The Federal Communications Commission and Industry Canada has reviewed the technical characteristics of the test facilities at TÜV Rheinland EPS B.V., located in Niekerk, 9822 TL Smidshornerweg 18, The Netherlands, and has found these test facilities to be in compliance with the requirements of 47 CFR Part 15, section 2.948, per October 23, 2000.

The description of the test facilities has been filed at the Office of the Federal Communications Commission under registration number 90828. The facility has been added to the list of laboratories performing these test services for the public on a fee basis.

The description of the test facilities has been filed to Industry Canada under registration number 2932G-1. The facility has been added to the list of laboratories performing these test services for the public on a fee basis.

1.6 Test conditions.

Normal test conditions:

Temperature (*)	: +15°C to +35°C
Relative humidity(*)	: 20 % to 75 %
Supply voltage	: 115VAC/60Hz to the AC/DC Power Supply – the DC output was varied across the voltage range specified by the manufacturer
Air pressure	: 950 – 1050 hPa

When it was impracticable to carry out the tests under these conditions, a note to this effect stating the ambient temperature and relative humidity during the tests are stated separately.

2 System test configuration.

2.1 Justification.

The system was configured for testing in a typical fashion (as a customer would normally use it).

The justification and manipulation of cables and equipment in order to simulate a worst-case behavior of the test setup has been carried out as prescribed in ANSI C63.4: 2003.

2.2 EUT mode of operation.

The EUT has been tested in active mode, i.e. the EUT is ready to detect a tag. To assess the behavior of the EUT while reading the tag, the EUT is tested with a tag presented such that it continuously reads the tag. The intentional radiator tests (47 CFR Part 15 sections, 15.207 and 15.209) have been performed with a complete functioning EUT and interconnections.

2.3 Special accessories.

No special accessories are used and/or needed to achieve compliance.

2.4 Equipment modifications.

No modifications have been made to the equipment in order to achieve compliance.

2.5 Product Labelling

The product labeling information is available in the technical documentation package.

2.6 Block diagram of the EUT.

The block diagram is available in the technical documentation package.

2.7 Schematics of the EUT.

The schematics are available in the technical documentation package.

2.8 Part list of the EUT.

The part list is available in the technical documentation package.

3 Radiated emission data.

3.1 Radiated field strength measurements (30 MHz – 1 GHz, E-field)

Frequency (MHz)	Measurement results @3m Vertical (dBuV/m)	Measurement results @3m Horizontal (dBuV/m)	Limits @3m (dBuV/m)	Pass/Fail
33.33	27.5	17.9	40.0	pass
36.87	26.6	16.0	40.0	pass
42.01	28.5	13.5	40.0	pass
52.01	28.4	8.9	40.0	pass
56.01	21.0	7.8	40.0	pass
59.58	21.5	7.0	40.0	pass
63.88	28.4	7.0	40.0	pass
65.49	30.0	7.2	40.0	pass
69.51	28.9	7.5	40.0	pass
79.44	19.4	9.0	40.0	pass
150.01	21.4	13.7	43.5	pass
209.97	14.6	12.6	43.5	pass
210 - 1000*	17.6	12.6	46.0	pass

Table 1

Radiated emissions of the EUT. The results of the radiated emission tests, carried out in accordance with 47 CFR Part 15 section 15.209 with the EUT operating in active mode on 134.2 kHz while detecting a tag are depicted in table 1. The system is tested as in whole, so with all equipment as shown in Figure.1 in place and functioning. Being the worst case situation.

Notes:

1. Field strength values of radiated emissions at frequencies not listed in the table above are more than 20 dB below the applicable limit.
2. Measurement uncertainty is ± 5.0 dB
3. The reported field strength values are the worst case values at the indicated frequency. The EUT was varied in three positions, the antenna was varied in horizontal and vertical orientations and also in height (between 1m and 4m).
4. A Quasi-peak detector was used with a resolution bandwidth of 120 kHz, except for frequencies above 960 MHz where an average detector was used.

Test engineer

Signature :



Name : Richard van der Meer

Date : January 29 , 2009

3.2 Radiated field strength measurements (frequency range of 0.009-30 MHz, H-field)

Frequency (MHz)	Measurement results (dB μ V)		Antenna factor (dB)	Cable loss (dB)	Measurement results (calculated) (dB(μ V)/m)	Limits Part 15.209 (dB(μ V)/m)
	3 meters	10 meters				
0.009 - 0.490 Except 0.134	<27	n.i	20.1	1	n.i	48.5 – 13.8 (300 m)
0.490 - 1.705	<20	n.i	19.7	1	n.i	33.8 - 22.9 (30 m)
1.705 – 30.0	n.i	n.i	19.5	1	n.i	29.5 (30 m)
0.1342 (fundamental)	92.1	61.9	20.1	1	-2.31 (300m)	25.05 (300m)

Table 2

Radiated emissions of the EUT. The results of the radiated emission tests, carried out in accordance with 47 CFR Part 15 section 15.209 with the EUT operating in continuous transmit mode on 134.2 kHz are depicted in table 2.

Notes:

1. Calculated measurement results are obtained by using the calculation as mentioned in Appendix 1 and the antenna factor and cable loss is included.
2. Frequency range:
 except for a. and b. below a Quasi-Peak detector was used during testing.
 - a. 9- 90 kHz Average detector used during measurements
 - b. 110-490 kHz Average detector used during measurements
3. A resolution bandwidth of 9kHz was used during testing
4. n.i. Indicates that no field strength values could be measured on the listed frequencies or in the listed frequency range.
5. Field strength values of radiated emissions at frequencies not listed in table 2 are more than 20 dB below the applicable limit
6. The EUT was varied in three positions, the loop antenna was varied in horizontal and vertical orientations and also around it's axis. The reported value is the worst case found at the reported frequency.
7. The EUT was tested in both normal mode (i.e. without a tag in its proximity) and in activated mode (i.e. with a tag in its proximity).
8. Measurement uncertainty is ± 5.0 dB

Test engineer

Signature : 

Name : R. van der Meer

Date : January 30, 2009

4 Carrier stability under special conditions.

4.1 Frequency stability in accordance with 47 CFR Part 15, section 15.31:

- 1) The frequency tolerance of the carrier signal shall be maintained within +/- 0.01% of the operating frequency over a temperature variation of -20 °C to +50 °C at normal supply voltage (see table 3).
- 2) Variation in temperature is not a requirement, tested for information only.

Stability under special conditions	Measured frequency (kHz)	Frequency deviation (limit $\pm 0.01\%$) (%)	PASS/FAIL
Temperature (°C)			
20.0	134.200 (reference)	N.A.	N.A.
-20.0	134.200	0.00	N.A.
50.0	134.200	0.00	N.A.

Table 3.

4.1.1 At 85% and 115% of rated voltage supply level

The frequency tolerance of the carrier signal shall be maintained within +/- 0.01% of the operating frequency at 85% and at 115% of the rated power supply voltage at 20 °C environmental temperature. The results are stated in Table 4.

Stability under special conditions	Measured frequency (MHz)	Frequency deviation (limit $\pm 0.01\%$) (%)	PASS/FAIL
% variation U			
100.0	134.200 (reference)	N.A.	N.A.
85.0	134.200	0.00	PASS
115.0	134.200	0.00	PASS

Table 4

5 Conducted emission data.

5.1 Conducted emission data of the EUT

Frequency (MHz)	Measurement results dB(μV) Neutral		Measurement results dB(μV) Line 1		Limits dB(μV)		Result
	QP	AV	QP	AV	QP	AV	
0.210	38.5	38.4	23.1	21.8	63.2	53.2	PASS
0.315	45.7	37.1	43.9	34.1	59.8	49.8	PASS
0.725	34.0	33.7	26.2	17.2	56	46	PASS
1.245	32.6	32.2	21.5	13.1	56	46	PASS
4.050	32.0	30.7	27.9	26.4	56	46	PASS
9.085	42.4	20.1	42.3	25.3	60	50	PASS

Table 5

Conducted emission measurements. The results of the conducted emission tests, carried out in accordance with 47 CFR Part 15 section 15.207, at the 115 Volts AC mains connection terminals of the AC/DC power supply which was connected to the EUT, are depicted in table 5. The EUT was tested in both passive and active mode (while detecting a card). The system is tested as in whole, so with all equipment as shown in Figure.1 in place and functioning. Being the worst case situation Maximum values recorded.

Notes:

1. Measurement uncertainty is ± 3.5 dB
2. The resolution bandwidth used was 9 kHz.

Test engineer

Signature : 

Name : R. van der Meer

Date : January 28, 2009

6 List of utilized test equipment.

Inventory number	Description	Brand	Model	Last cal.	Next cal.
12482	Loop antenna	EMCO	6507	05/2008	05/2009
12503	LISN	R&S	ESH2-Z5	01/2008	01/2010
12513	LISN	EMCO	3625/2	01/2008	01/2010
12640	Temperature chamber	Heraeus	VEM03/500	01/2009	01/2010
15275	Spectrum analyzer	HP	8594E	10/2008	10/2009
15633	Biconilog Testantenna	Chase	CBL 6111B	02/28/2008	02/28/2009
15667	Measuring receiver	R&S	ESCS 30	04/2008	04/2009
99045	Power supply	Delta	E030-3	04/2008	04/2009
99069	Coax 5m RG213 OATS	NMi Certin B.V.	KABEL 5M OATS	11/2008	11/2009
99070	Coax 15m RG213 OATS	NMi Certin B.V.	KABEL 15M OATS	11/2008	11/2009
99071	Coax OATS ground	NMi Certin B.V.	KABEL GROND OATS	11/2008	11/2009
99107	Controller OATS	Heinrich Deisel	4630-100	NA	NA
99318	Digital multimeter	HP	34401A	10/2008	10/2009
99538	Spectrum analyzer	R&S	FSP40	05/2008	05/2009
99538	Spectrum analyzer	R&S	FSP40	05/2008	05/2009
99547	Temperature-Humiditymeter	Europe supplies	WS-7082	10/2008	10/2009
99580	OATS	Comtest	FCC listed: 90828	08/2008	08/2011
99580	Open Area testsite	Comtest	NA	09/2006	09/2009
99608	Controller (OATS)	EMCS	DOC202	NA	NA
99609	Antenna mast	EMCS	AP-4702C	NA	NA
99613	Temperature-Humiditymeter	Europe supplies	WS-7082	10/2008	10/2009
99615	Laptop	IBM	Lenovo 9456-HTG	NA	NA
99651	Variac	NA	Vast Activa: 08-9510	NA	NA
99683	Loop antenna, 6cm	NA	7405-901	9/2008	9/2009
99699	Measuring receiver	R&S	ESCI	11/2008	11/2009

NA= Not Applicable

Appendix 1

Calculated measurements results radiated field strength, H-Field

The rules of Part 15 section 15.31 allow scaling of the measured values or limits when measurements are made at distances other than those specified. The extrapolation factor for frequencies below 30 MHz are 40 dB/decade which means that for a distance change of 10 to 1 (a decade), the limit, or measured value, may be recalculated by adding (moving closer) or subtracting (moving away) 40 dB, respectively.

It is also possible to make radiated-emission measurements at two different distances and extrapolate to a third distance. The calculation method described below, should then be followed.

General Formula:

d_1 = short distance

d_2 = long distance

So:

$$(d_1/d_2)^n = H_{d2}/H_{d1}$$

$$n \log(d_1/d_2) = \log(H_{d2}/H_{d1})$$

Calculation of n:

$$n = \log(H_{d2}/H_{d1}) / \log(d_1/d_2)$$

Calculation of field strength at other distance (10m --> 300m):

$$H_{d2} = H_{d1} (d_1/d_2)^n$$

Example

For the fundamental frequency of 134.2 kHz the level at a distance of 300m would be calculated as follows:

$d_1 = 3\text{m}$

$d_2 = 10\text{m}$

Calculation for n: $n = \log(H_{d2}/H_{d1}) / \log(d_1/d_2) > n = \log(92.1/61.9) / \log(3\text{m}/10\text{m}) > n = 2.8878$

$$H_{d2} = H_{d1} (d_1/d_2)^n > H_{d2} = 92.1 (3/10)^{2.8878} = -2.31 \text{ dB}(\mu\text{V})/\text{m}.$$