

**TEST REPORT CONCERNING THE COMPLIANCE OF
A 134 KHZ INDUCTIVE PROXIMITY TAG READER
BRAND NEDAP,
MODEL VELOS, VP1006-VP1002;
WITH VP6001 ANTENNA,
WITH 47 CFR PART 15 (2006-08-14).**

FCC listed : 90828
Industry Canada : IC3501
VCCI registered : R-1518, C-1598

TNO Electronic Products & Services (EPS) B.V.
P.O. Box 15
9822 ZG Niekerk (NL)
Smidshornerweg 18
9822 TL Niekerk (NL)

Telephone: +31 594 505005
Telefax: +31 594 504804

E-mail: info@tno-eps.com

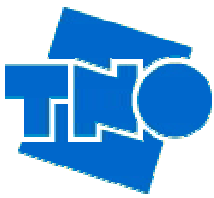

Test specification(s): 47 CFR Part 15 (2006-08-14)
Description of EUT: Inductive proximity tag reader
Manufacturer: N.V. Nederlandsche Apparatenfabriek "NEDAP"
Brand mark: Nedap
Model: VELOS VP1006-VP1002, with VP1006 antenna
FCC ID: CGDVELOS2

MEASUREMENT/TECHNICAL REPORT

Nedap N.V.

Model : VELOS VP1006-VP1002

FCC ID: CGDVELOS2

March 21, 2007

(replaces version 06121202.fcc02 of February 22, 2007)

This report concerns:	Original grant/certification	Class 2 change	Verification
Equipment type:	134 kHz inductive proximity tag reader		
Deferred grant requested per 47 CFR 0.457(d)(1)(ii) ?	Yes	No	n.a.
Report prepared by:	Name	: A. van der Valk, B.Sc.E.E.	
	Company name	: TNO Electronic Products & Services (EPS) B.V.	
	Address	: Smidshornerweg 18	
	Postal code/city	: 9822 TL Niekerk	
	Mailing address	: P.O. Box 15	
	Postal code/city	: 9822 ZG Niekerk	
	Country	: The Netherlands	
	Telephone number	: + 31 594 505 005	
	Telefax number	: + 31 594 504 804	
	E-mail	: info@tno-eps.com	

The data taken for this test and report herein was done in accordance with 47 CFR Part 15 and the measurement procedures of ANSI C63.4-2003. TNO Electronic Products & Services (EPS) B.V. at Niekerk, The Netherlands, certifies that the data is accurate and contains a true representation of the emission profile of the Equipment Under Test (EUT) on the date of the test as noted in the test report. I have reviewed the test report and find it to be an accurate description of the test(s) performed and the EUT so tested.

Date: March 21, 2007

Signature:

H.J. Pieters

Project Manager TNO Electronic Products & Services (EPS) B.V.



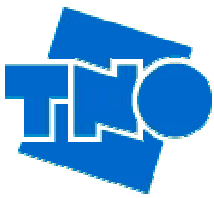

Test specification(s): 47 CFR Part 15 (2006-08-14)
Description of EUT: Inductive proximity tag reader
Manufacturer: N.V. Nederlandsche Apparatenfabriek "NEDAP"
Brand mark: Nedap
Model: VELOS VP1006-VP1002, with VP1006 antenna
FCC ID: CGDVELOS2

Description of test item

Test item : 134 kHz Inductive proximity tag reader
Manufacturer : N.V. Nederlandsche Apparatenfabriek "NEDAP"
Brand : Nedap
Model : Velos VP1006-VP1002
Serial number(s) : Not available
Revision : Not available
Receipt date : Not available

Applicant information

Applicant's representative : Mr. D. Roosenboom
Company : N.V. Nederlandsche Apparatenfabriek "NEDAP"
Address : Parallelweg 2
Postal code : 7141 DC
City : Groenlo
PO-box : 6
Postal code : 7140 AA
City : Groenlo
Country : The Netherlands
Telephone number : +31 (0) 544 471111
Telefax number : +31 (0) 544 463475

Test(s) performed

Location : Niekerk
Test(s) started : December 6, 2006
Test(s) completed : January 30, 2007
Purpose of test(s) : Equipment Authorisation (Certification).

Test specification(s) : 47 CFR Part 15 (2006-08-14)

Test engineers : A. van der Valk
O.H. Hoekstra

Report written by : A. van der Valk

Report date : March 21, 2007 (replaces version 06121202.fcc02 of February 22, 2007)

This report is in conformity with NEN-EN-ISO/IEC 17025: 2000.

This report shall not be reproduced, except in full, without the written permission of TNO Electronic Products & Services (EPS) B.V.
The test results relate only to the item(s) tested.

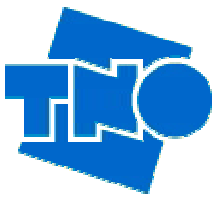

Test specification(s): 47 CFR Part 15 (2006-08-14)
Description of EUT: Inductive proximity tag reader
Manufacturer: N.V. Nederlandsche Apparatenfabriek “NEDAP”
Brand mark: Nedap
Model: VELOS VP1006-VP1002, with VP1006 antenna
FCC ID: CGDVELOS2

Table of contents

1	General information.....	5
1.1	Product description.....	5
1.1.1	Introduction.....	5
1.2	Related submittal(s) and/or Grant(s).....	5
1.3	Tested system details.....	5
1.3.1	Description of input and output ports.....	7
1.4	Test methodology.....	7
1.5	Test facility.....	7
1.6	Test conditions.....	8
2	System test configuration.....	9
2.1	Justification.....	9
2.2	EUT mode of operation.....	9
2.3	Special accessories.....	9
2.4	Equipment modifications.....	9
2.5	Block diagram of the EUT.....	9
2.6	Schematics of the EUT.....	9
2.7	Part list of the EUT.....	9
3	Radiated emission data.....	10
3.1	Radiated field strength measurements (30 MHz – 1 GHz, E-field).....	10
3.2	Radiated field strength measurements (frequency range of 0.009-30 MHz, H-field).....	11
4	Conducted emission data.....	12
4.1	Conducted emission data of the EUT.....	12
5	Carrier stability under special conditions.....	13
5.1	Frequency stability in accordance with 47 CFR Part 15:.....	13
5.2	Amplitude stability in accordance with 47 CFR Part 15, sections 15.31 (e).....	13
6	List of utilized test equipment.....	14

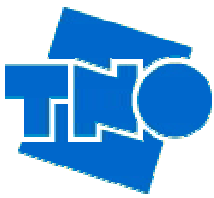

Test specification(s): 47 CFR Part 15 (2006-08-14)
Description of EUT: Inductive proximity tag reader
Manufacturer: N.V. Nederlandsche Apparatenfabriek "NEDAP"
Brand mark: Nedap
Model: VELOS VP1006-VP1002, with VP1006 antenna
FCC ID: CGDVELOS2

1 General information.

1.1 Product description.

1.1.1 Introduction.

The EUT is a 134 kHz inductive proximity tag reader intended to be used as cattle identification and motor control for feeding purposes.

This report is an amended report in which the FCC ID has been modified. The content of this report and measurement results have not been changed other than a clarification related to the data depicted in the table 2

1.2 Related submittal(s) and/or Grant(s).

Not applicable.

1.3 Tested system details.

Details and an overview of the system and all of its components, as it has been tested, may be found below.

EUT (item 1)	:	OEM ISO-Reader (134 kHz)
Manufacturer	:	N.V. Nederlandsche Apparatenfabriek "NEDAP"
Brand	:	NEDAP
Model	:	VP1006
Serial number	:	-
Voltage input rating	:	24 VDC
Current input rating	:	-
Voltage output rating	:	-
Current output rating	:	-
Remarks	:	The VP1006 has the following main tasks : - Identification of tags (134 kHz FDX/HDX) - Controlling outputs, 6 outputs available to activate e.g. lights, motors, valves, relays. - Reading inputs, 6 inputs available for e.g. sensors, switches

EUT (item 2)	:	ISO-Booster
Manufacturer	:	N.V. Nederlandsche Apparatenfabriek "NEDAP"
Brand	:	NEDAP
Model	:	VP1002
Serial number	:	-
Voltage input rating	:	24 VDC, +/-20%
Current input rating	:	-
Voltage output rating	:	-
Current output rating	:	-
Remarks	:	The ISO Booster or VP1002 is used for improving reading distance of antennas specially in case of using small (ear) tags. The ISO Booster must be connected to a V-pack.

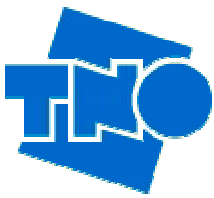

Test specification(s): 47 CFR Part 15 (2006-08-14)
Description of EUT: Inductive proximity tag reader
Manufacturer: N.V. Nederlandsche Apparatenfabriek "NEDAP"
Brand mark: Nedap
Model: VELOS VP1006-VP1002, with VP1006 antenna
FCC ID: CGDVELOS2

EUT (item 3) : V-sense Antenna (height 120 cm wide 50 cm)
Manufacturer : N.V. Nederlandsche Apparatenfabriek "NEDAP"
Brand : NEDAP
Model : VP6001
Serial number : -
Voltage input rating : -
Current input rating : -
Voltage output rating : -
Current output rating : -
Remarks : The VP6001 is used as antenna in Velos system and connected to a V-pack.
The VP6001 is connected to a V-pack by a coax cable, see manual of the concerning V-pack.

Ancillary equipment:

Ancillary item 1 : Power supply
Manufacturer : N.V. Nederlandsche Apparatenfabriek "NEDAP"
Brand : NEDAP
Model : VP2001
Serial number :
Voltage input rating : 87 -265 VAC 47 – 63 Hz
Current input rating : -
Voltage output rating : Output 1, 2 and 3: 25.0 +/- 0.5 VDC
Current output rating : Output 1 and 2: 4A max. Output 3: 1 A max
Remarks : Output 1 used for the tests in this report, The VP2001 is used as power supply in the Velos system and is connected to the VP 1006.

1.3.1 Description of input and output ports.

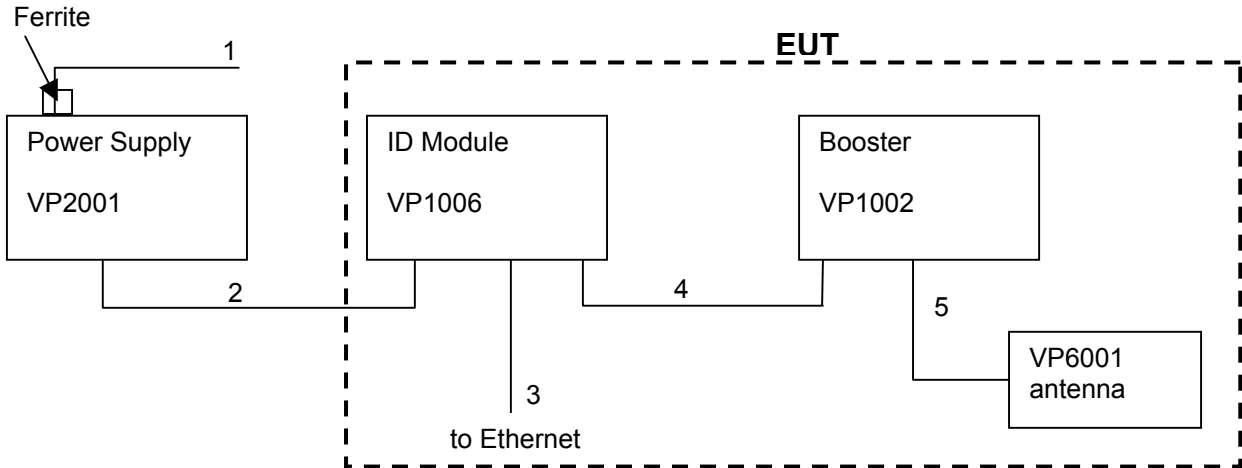

Number	Ports	From	To	Shielding	Remarks
1	AC mains	AC mains	VP2001	yes / no	None
2	DC power input port	VP2001	VP1006	yes / no	None
3	Ethernet	VP8001	Ethernet device	yes / no	> 3 m Ethernet cable UTP
4	DC power input port	VP1006	VP1002	yes / no	None
5	External antenna port	VP1002	VP6001	yes / no	None

1.4 Test methodology.

The test methodology used is based on the requirements of 47 CFR Part 15 (2006-08-14), sections 15.207 and 15.209.

The test methods, which have been used, are based on ANSI C63.4: 2003.

Radiated emission tests above 30 MHz were performed at a measurement distance of 3 meters.

Radiated emission tests below 30 MHz were performed at a measurement distance of 3 meters and if necessary at 10 and 30 meters. To calculate the field strength level from these results to the appropriate distance at which the limit is specified, the computation method in appendix 1 has been applied.

1.5 Test facility.

The Federal Communications Commission has reviewed the technical characteristics of the test facilities at TNO Electronic Products & Services (EPS) B.V., located in Niekerk, 9822 TL Smidshornerweg 18, The Netherlands, and has found these test facilities to be in compliance with the requirements of 47 CFR Part 2, section 2.948.

The description of the test facilities has been filed at the Office of the Federal Communications Commission under registration number 90828. The facility has been added to the list of laboratories performing these test services for the public on a fee basis.

The list of all public test facilities is available on the Internet at <http://www.fcc.gov>.

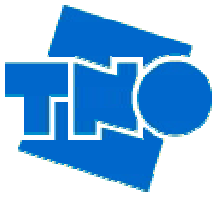

Test specification(s): 47 CFR Part 15 (2006-08-14)
Description of EUT: Inductive proximity tag reader
Manufacturer: N.V. Nederlandsche Apparatenfabriek "NEDAP"
Brand mark: Nedap
Model: VELOS VP1006-VP1002, with VP1006 antenna
FCC ID: CGDVELOS2

1.6 Test conditions.

Normal test conditions.

Temperature (*) : +15°C to +35°C
Relative humidity(*) : 20 % to 75 %
Supply voltage : 115 VAC
Air pressure : 950 – 1050 hPa

* When it was impracticable to carry out the tests under these conditions, a note to this effect stating the ambient temperature and relative humidity during the tests are stated separately.

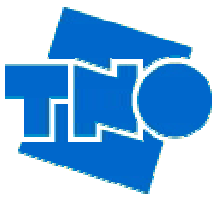

Test specification(s): 47 CFR Part 15 (2006-08-14)
Description of EUT: Inductive proximity tag reader
Manufacturer: N.V. Nederlandsche Apparatenfabriek "NEDAP"
Brand mark: Nedap
Model: VELOS VP1006-VP1002, with VP1006 antenna
FCC ID: CGDVELOS2

2 System test configuration.

2.1 Justification.

The justification and manipulation of cables and equipment in order to simulate a worst-case behavior of the test setup has been carried out as prescribed in ANSI C63.4: 2003.

2.2 EUT mode of operation.

The EUT has been tested in active mode, i.e. the EUT is ready to detect a tag. The EUT was set to maximum power output, and the antenna tuning was executed as described in the manual.

All test set ups have been documented in pictures in the documentation package which will be submitted to the Commission

2.3 Special accessories.

No special accessories are used and/or needed to achieve compliance with the applicable sections of 47 CFR Part 15.

2.4 Equipment modifications.

No modifications have been made to the equipment in order to achieve compliance with the appropriate sections of 47 CFR Part 15.

2.5 Block diagram of the EUT.

The block diagram is available in the technical documentation package which will be submitted to the Commission.

2.6 Schematics of the EUT.

The schematics are available in the technical documentation package which will be submitted to the Commission.

2.7 Part list of the EUT.

The part list is available in the technical documentation package which will be submitted to the Commission.

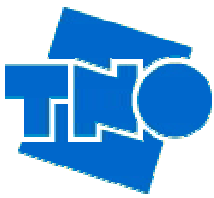

Test specification(s): 47 CFR Part 15 (2006-08-14)
Description of EUT: Inductive proximity tag reader
Manufacturer: N.V. Nederlandsche Apparatenfabriek "NEDAP"
Brand mark: Nedap
Model: VELOS VP1006-VP1002, with VP1006 antenna
FCC ID: CGDVELO2

3 Radiated emission data.

3.1 Radiated field strength measurements (30 MHz – 1 GHz, E-field).

Frequency (MHz)	Measurement results dB(μ V)/m @ 3 metres Quasi-peak		Limits dB(μ V)/m @ 3 metres Quasi-peak	Margin (dB) Quasi-peak		Result
	Vertical	Horizontal		Vertical	Horizontal	
30 – 72.20	n.i.	n.i.	40.0	-	-	PASS
72.20	30.6	22.4	40.0	-9.4	-17.6	PASS
72.46	30.0	23.1	40.0	-10.0	-16.9	PASS
73.00	32.1	24.5	40.0	-7.9	-15.5	PASS
73.00 - 300	n.i.	n.i.	46.0	-	-	PASS
300 - 1000	n.i.	n.i.	46.0 – 54.0	-	-	PASS

Table 1: Radiated emissions of the EUT.

The results of the radiated emission tests, carried out in accordance with 47 CFR Part 15, section 15.209, are depicted in table 1.

Notes:

1. (AV) average detector
2. (QP) quasi peak detector
3. The computation method for calculation of the field strength at different distances can be found in Appendix 1.
4. Frequency range: 9-90 kHz and 110-490 kHz: Average detector (AV) used during measurements.
5. n.i. indicates that no field strength values related to the EUT could be measured for the listed frequency or for the listed frequency range.
6. << indicates that field strength values of radiated emissions are more than 20 dB below the applicable limit.
7. The reported field strength values are the worst case values at the indicated frequency, obtained by rotation of the EUT and orientation of the antenna.
8. Up to the 10 th harmonic of the transmit frequency was investigated, as per 47 CFR Part 15 section 15.33

Test engineer

signature :

Name : A. van der Valk

Date : January 10, 2007

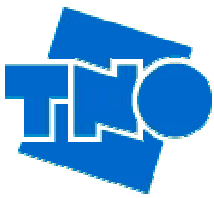

Test specification(s): 47 CFR Part 15 (2006-08-14)
Description of EUT: Inductive proximity tag reader
Manufacturer: N.V. Nederlandsche Apparatenfabriek "NEDAP"
Brand mark: Nedap
Model: VELOS VP1006-VP1002, with VP1006 antenna
FCC ID: CGDVELOS2

3.2 Radiated field strength measurements (frequency range of 0.009-30 MHz, H-field).

Frequency (kHz)	Measurement results dB μ V		Antenna factor dB	Cable loss dB	Calculated results dB(μ V)/m	Limits Part 15.209 dB(μ V)/m
	10 meters	30 meters				
9.00 – 134.00	n.i.	-	-	-	-	-
134.21	79.7 (AV)	55 (AV)	20.1	1	24.3	25.1 (300 m)
268.42	33.6 (AV)	n.i.	20.0	1	<<	19.0 (300 m)
536.84	31.4 (QP)	n.i.	20.0	1	<<	33.0 (30 m)
536.84- 1705	n.i.	-	-	-	-	-
1.705 – 30.0 MHz	n.i.	-	-	-	-	-

Table 2: Radiated emissions of the EUT.

The results of the radiated emission tests, carried out in accordance with 47 CFR Part 15, sections 15.205 and 15.209, are depicted in table 2. Measurement results are readings from the measuring device in dB μ V. Using the appropriate antenna factor and cable losses, these readings are expressed directly into dB(μ V)/m and are recalculated at distances as appropriate.

Notes:

- (AV) average detector
- (QP) quasi peak detector
- The computation method for calculation of the field strength at different distances can be found in Appendix 1.
- Frequency range: 9-90 kHz and 110-490 kHz: Average detector (AV) used during measurements.
- n.i. indicates that no field strength values related to the EUT could be measured for the listed frequency or for the listed frequency range.
- << indicates that field strength values of radiated emissions are more than 20 dB below the applicable limit.
- The reported field strength values are the worst case values at the indicated frequency, obtained by rotation of the EUT and orientation of the antenna.

Test engineer

signature

Name

: A. van der Valk

Date

: January 11, 2007

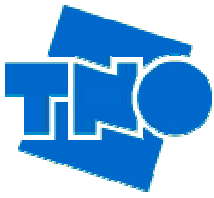

Test specification(s): 47 CFR Part 15 (2006-08-14)
 Description of EUT: Inductive proximity tag reader
 Manufacturer: N.V. Nederlandsche Apparatenfabriek "NEDAP"
 Brand mark: Nedap
 Model: VELOS VP1006-VP1002, with VP1006 antenna
 FCC ID: CGDVELOS2

4 Conducted emission data.

4.1 Conducted emission data of the EUT

Frequency (MHz)	Measurement results dB(μ V) Neutral		Measurement results dB(μ V) Line 1		Limits dB(μ V)		Margin (dB) Neutral		Margin (dB) Line 1		Result
	QP	AV	QP	AV	QP	AV	QP	AV	QP	AV	
0.214	34.7	34.8	<10.0	<10.0	63.0	55.2	-28.3	-20.4	<-53.0	<-45.2	PASS
0.322	34.2	34.2	23.2	22.2	59.7	50.8	-25.5	-16.6	-36.5	-28.6	PASS
0.400	46.4	35.3	45.8	34.2	57.9	48.4	-11.5	-13.1	-12.1	-14.2	PASS
0.820	32.9	11.9	33.1	12.2	56.0	46.0	-23.1	-34.1	-22.9	-33.8	PASS
4.196	42.6	42.8	40.9	40.9	56.0	46.0	-13.4	-3.2	-15.1	-5.1	PASS
8.900	47.3	47.3	47.2	47.2	60.0	50.0	-12.7	-2.7	-12.8	-2.8	PASS
11.500	43.7	44.1	42.2	41.3	60.0	50.0	-16.3	-5.9	-17.8	-8.7	PASS

Table 3: Conducted emission measurements of the EUT

The results of the conducted emission tests, carried out in accordance with 47 CFR Part 15, section 15.207, are depicted in table 3

Notes:

1. The conducted emissions on frequencies which are not listed in the table above were found to be below 25 dB μ V on both neutral and line 1.

Test engineer

signature :

Name : A. van der Valk

Date : January 19, 2007

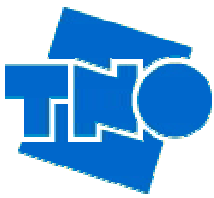

Test specification(s): 47 CFR Part 15 (2006-08-14)
Description of EUT: Inductive proximity tag reader
Manufacturer: N.V. Nederlandsche Apparatenfabriek "NEDAP"
Brand mark: Nedap
Model: VELOS VP1006-VP1002, with VP1006 antenna
FCC ID: CGDVELOS2

5 Carrier stability under special conditions.

5.1 Frequency stability in accordance with 47 CFR Part 15:

From measurements performed as indicated below, the frequency stability will not cause non-compliant situations with respect to exclusion bands or emissions outside permissible bands (band edges)

Stability under special conditions Temperature (°C)	Measured frequency (kHz)	Frequency deviation (%)
20.0	134.200 (reference)	N.A.
-20	134.200	0
50	134.200	0

Stability under special conditions % variation U	Measured frequency (kHz)	Frequency deviation (%)
0	134.200 (reference)	N.A.
-15	134.200	0
+15	134.200	0

5.2 Amplitude stability in accordance with 47 CFR Part 15, sections 15.31 (e).

Variation of the supply voltage between 85% and 115% of the nominal rated supply voltage, showed no variation of the radiated signal level of the fundamental frequency component.

EUT amplitude stability measured at 3 different power supply voltages determined at 21 degrees C.

Stability under special conditions % U	Measured output (relative)	Amplitude deviation (dB)
100.0	63.8 (reference)	N.A.
85.0	63.8	0
115.0	63.8	0

Test engineer

signature

:

Name

: O.H. Hoekstra

Date

: January 29, 2007

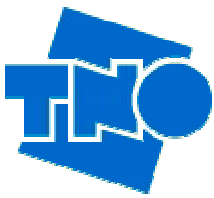

Test specification(s): 47 CFR Part 15 (2006-08-14)
Description of EUT: Inductive proximity tag reader
Manufacturer: N.V. Nederlandsche Apparatenfabriek "NEDAP"
Brand mark: Nedap
Model: VELOS VP1006-VP1002, with VP1006 antenna
FCC ID: CGDVELOS2

6 List of utilized test equipment.

Inventory number	Description	Brand	Model
12512	LISN FCC	Emco	3725/2
12636	Polyester chamber	Polyforce	--
13313	Pulse limiter	R&S	ESH3-Z2
13886	Open Area testsite	Comtest	--
14051	Anechoic room	Comtest	--
15633	Biconilog Testantenna	Chase	CBL 6111B
15667	Measuring receiver	R&S	ESCS 30
99055	Non-conducting support	NMi	--
99061	Non-conducting support 150cm	NMi	--
99077	Regulating trafo	RFT	LTS006
15453	Loop antenna	Chase	HLA6120
12636	Polyester chamber	Polyforce	--
13886	Open Area testsite	Comtest	--
99069	Cable 5m RG214	NMi	--
99071	Cable 10m RG214	NMi	--
99077	Regulating trafo	RFT	LTS006
99112	Tripod	Chase	--
12476	Antenna mast	EMCO	TR3
12477	Antenna mast 1-4 mtr	Poelstra	--

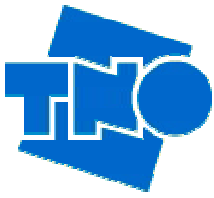

Test specification(s): 47 CFR Part 15 (2006-08-14)
Description of EUT: Inductive proximity tag reader
Manufacturer: N.V. Nederlandsche Apparatenfabriek "NEDAP"
Brand mark: Nedap
Model: VELOS VP1006-VP1002, with VP1006 antenna
FCC ID: CGDVELOS2

Appendix 1

Calculated measurements results radiated field strength, H-Field

The rules of Part 15 section 15.31 allow scaling of the measured values or limits when measurements are made at distances other than those specified. The extrapolation factor for frequencies below 30 MHz are 40 dB/decade which means that for a distance change of 10 to 1 (a decade), the limit, or measured value, may be recalculated by adding (moving closer) or subtracting (moving away) 40 dB, respectively.

It is also possible to make radiated-emission measurements at two different distances and extrapolate to a third distance. The calculation method described below, should then be followed.

General Formula:

d_1 = short distance

d_2 = long distance

So:

$$(d_1/d_2)^n = H_{d2}/H_{d1}$$

$$n \log(d_1/d_2) = \log(H_{d2}/H_{d1})$$

Calculation of n:

$$n = \log(H_{d2}/H_{d1}) / \log(d_1/d_2)$$

Calculation of field strength at other distance (10m --> 300m):

$$H_{d2} = H_{d1} (d_1/d_2)^n$$