



**TEST REPORT CONCERNING THE COMPLIANCE OF A
RFID Cardreader
BRAND NEDAP, MODEL Convexs MN80
WITH 47 CFR PART 15 (JULY 10, 2008).

09070602.fcc02_Rev01 (120 kHz part)
February 12, 2010**

FCC listed : 90828
Industry Canada : 2932G-1
VCCI Registered : R-1518, C-1598
R&TTE, LVD, EMC Notified Body : 1856

**TÜV Rheinland EPS B.V.
P.O. Box 15
9822 ZG Niekerk (NL)
Smidshornerweg 18
9822 TL Niekerk (NL)**

Telephone: +31 594 505005
Telefax: +31 594 504804

E-mail: info@tuv-eps.com
Web: www.tuv-eps.com

MEASUREMENT/TECHNICAL REPORT

N.V. Nederlandsche Apparatenfabriek "Nedap"
Model : Convexs MN80
FCC ID: CGDCONVEXS

February 12, 2010

This report concerns: Original grant/certification Class 2 change Verification			
Equipment type: 120 kHz and 13.56 MHz Inductive Proximity Card Reader (This report deals with the 120 kHz part)			
Deferred grant requested per 47 CFR 0.457(d)(1)(ii) ?	Yes	No	n.a.
Report prepared by:	Name	: Richard van der Meer	
	Company name	: TÜV Rheinland EPS B.V.	
	Address	: Smidshornerweg 18	
	Postal code/city	: 9822 TL Niekerk	
	Mailing address	: P.O. Box 15	
	Postal code/city	: 9822 ZG Niekerk	
	Country	: The Netherlands	
	Telephone number	: + 31 594 505 005	
	Telefax number	: + 31 594 504 804	
	E-mail	: info@tuv-eps.com	

The data taken for this test and report herein was done in accordance with 47 CFR Part 15 (july 10, 2008) and the measurement procedures of ANSI C63.4-2003. TÜV Rheinland EPS B.V. at Niekerk, The Netherlands, certifies that the data is accurate and contains a true representation of the emission profile of the Equipment Under Test (EUT) on the date of the test as noted in the test report. I have reviewed the test report and find it to be an accurate description of the test(s) performed and the EUT so tested.

Date: February 12, 2010

Signature:



O. Hoekstra
Senior Engineer Telecom TÜV Rheinland EPS B.V.

Description of test item

Test item : RFID Cardreader
Manufacturer : N.V. Nederlandsche Apparatenfabriek "Nedap"
Brand : Nedap
Model(s) : Convexs MN80
Serial number(s) : 0030973117
Receipt date : August 10, 2009

Applicant information

Applicant's representative : Mr. J. Hulshof
Company : N.V. Nederlandsche Apparatenfabriek "Nedap"
Address : Parallelweg 2
Postal code : 7141 DC
City : Groenlo
Country : The Netherlands
Telephone number : +31 544 471 162
Telefax number : +31 544 466 475

Test(s) performed

Location : Niekerk
Test(s) started : August 11, 2009
Test(s) completed : January 13, 2010
Purpose of test(s) : Equipment Authorization (Original grant/certification)
Test specification(s) : 47 CFR Part 15 (July 10, 2008)

Test engineer(s) : R. van der Meer



Report written by : R. van der Meer



Report date : February 12, 2010

This report is in conformity with NEN-EN-ISO/IEC 17025: 2005
This report shall not be reproduced, except in full, without the written permission of TÜV Rheinland EPS B.V.
The test results relate only to the item(s) tested.

Table of contents

1	General information.....	5
1.1	Product description.....	5
1.1.1	Introduction.....	5
1.2	Related submittal(s) and/or Grant(s).....	5
1.2.1	General.....	5
1.3	Tested system details.....	5
1.3.1	Description of input and output ports.....	7
1.4	Test methodology.....	8
1.5	Test facility.....	8
1.6	Test conditions.....	8
2	System test configuration.....	9
2.1	Justification.....	9
2.2	EUT mode of operation.....	9
2.3	Special accessories.....	9
2.4	Equipment modifications.....	9
2.5	Product Labeling.....	9
2.6	Block diagram of the EUT.....	9
2.7	Schematics of the EUT.....	9
2.8	Part list of the EUT.....	9
3	Radiated emission data.....	10
3.1	Radiated field strength measurements (frequency range of 0.009-30 MHz, H-field).....	10
4	Conducted emission data.....	11
4.1	Conducted emission data of the EUT.....	11
5	Plot of the emission.....	12
6	List of utilized test equipment.....	13

1 General information.

1.1 Product description.

1.1.1 Introduction.

The RFID Cardreader, brand Nedap, Model Convexs MN80, operates on a frequency of 120 kHz and 13.56 MHz. This report deals with the 120 kHz part.

The content of this report and measurement results have not been changed other than the way of presenting the data.

1.2 Related submittal(s) and/or Grant(s).

1.2.1 General.

This test report supports the original grant/certification in equipment authorization files under **FCC ID: CGDCONVEXS**.

1.3 Tested system details.

Details and an overview of the system and all of its components, as it has been tested, may be found below.

EUT	:	RFID Cardreader
Manufacturer	:	N.V. Nederlandsche Apparatenfabriek "Nedap"
Brand	:	Nedap
Model	:	Convexs MN80
Serial number	:	0030973117
Voltage input rating	:	10 - 30 VDC
Voltage output rating	:	n.a.
Current input rating	:	not provided
Antenna	:	Internal
Remarks	:	n.a.

Aux: 1a	:	USB converter (USB/RS485)
Manufacturer	:	---
Brand	:	---
Model/partnumber	:	159666
Serial #/ID	:	---
Voltage input rating	:	---
Remarks	:	used for radiated emissions measurements

Aux: 1b	:	USB converter (USB/RS485)
Manufacturer	:	---
Brand	:	EasySync
Model/partnumber	:	USB-COMi-SI-M
Serial #/ID	:	---
Voltage input rating	:	---
Remarks	:	used for conducted emissions measurements

Aux: 2	:	Power supply
Manufacturer	:	Egston
Brand	:	Egston
Model/partnumber	:	---
Serial #/ID	:	---
Voltage input rating	:	100 - 230 V AC

Aux: 3	:	Laptop
Manufacturer	:	---
Brand	:	---
Model/partnumber	:	---
Serial #/ID	:	---
Voltage input rating	:	100 - 230 V AC

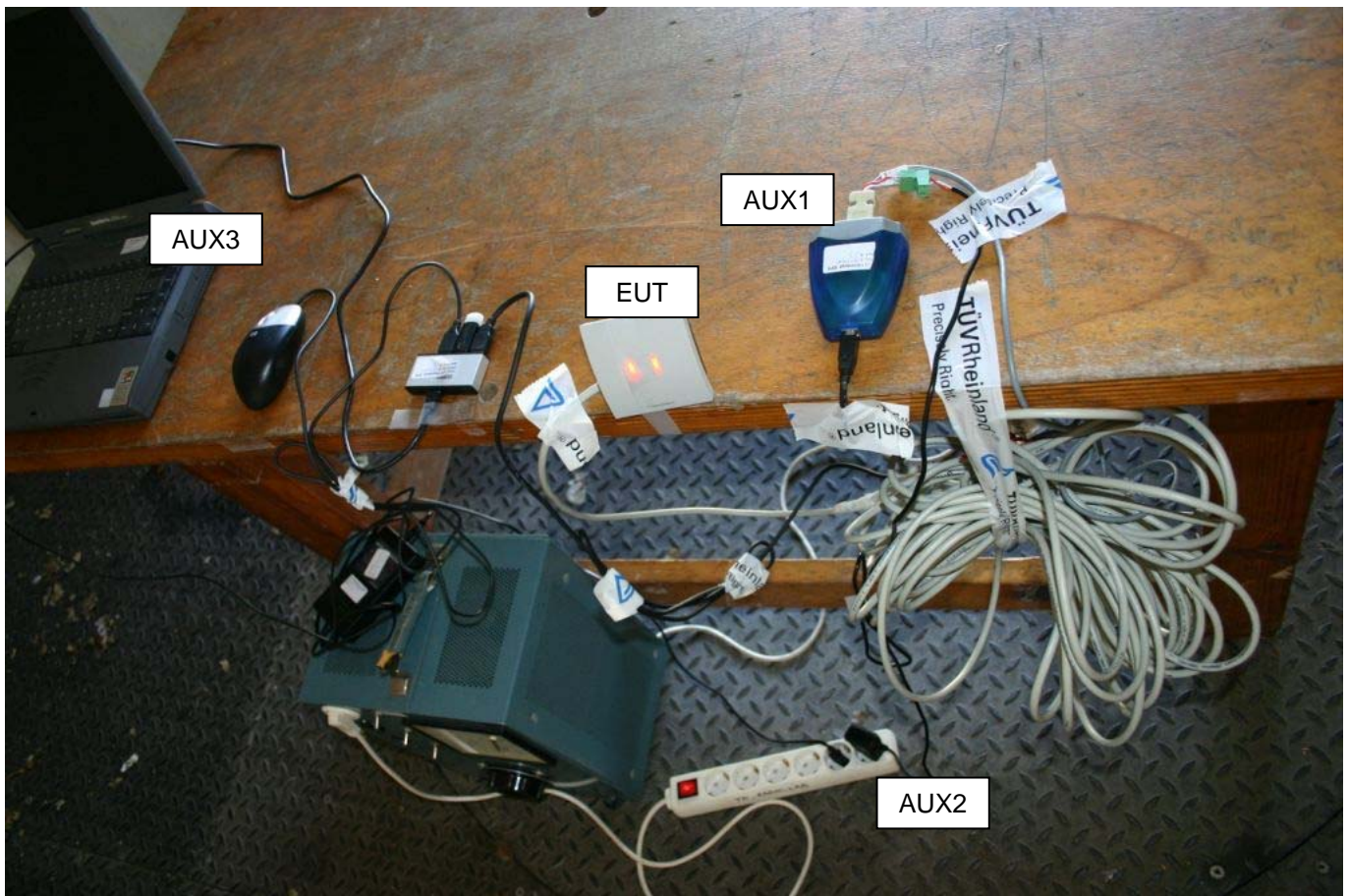

Photo 1: System overview

1.3.1 Description of input and output ports.

Number	Terminal	From	To	Length
1	AC Power	Mains	Aux 2	0 m
2	DC power	Aux 2	EUT	>> 3 m, shielded
3	Controller I/O	EUT	Aux 1	>> 3 m, shielded
4	USB	Aux 1	Aux 3	< 3 m, shielded

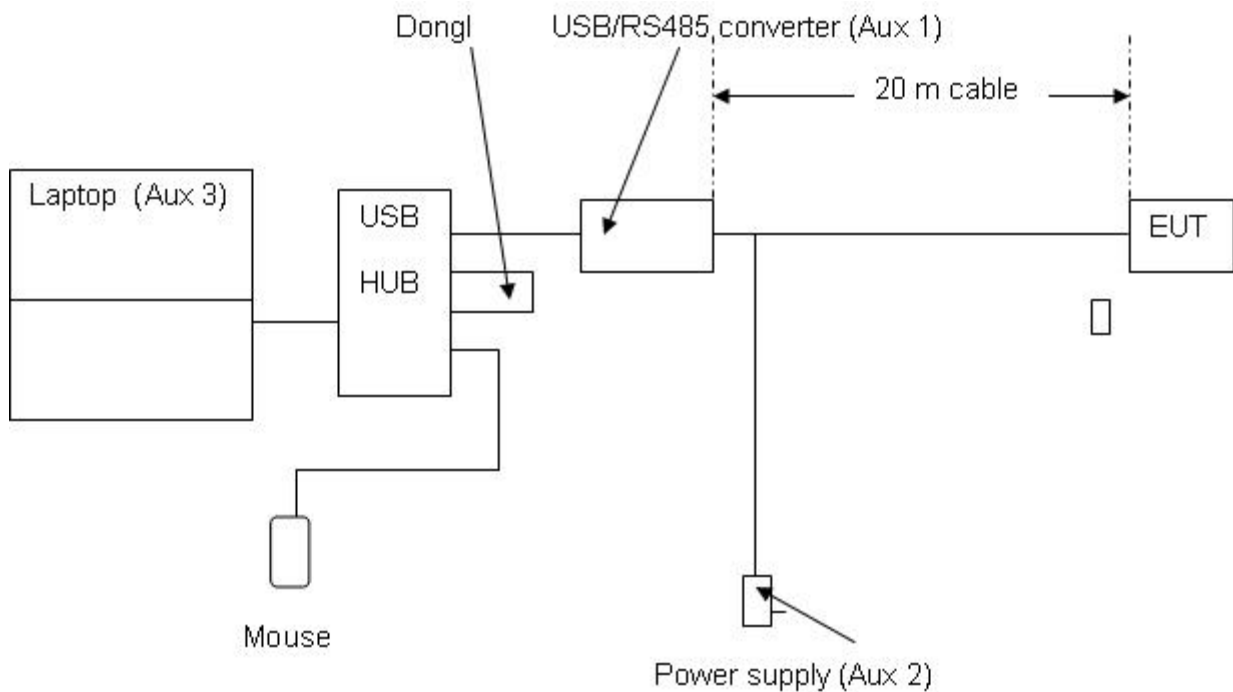

Figure 1. Basic test set-up during all tests

1.4 Test methodology.

The test methodology used is based on the requirements of 47 CFR Part 15 (july 10, 2008), sections 15.31, 15.207,15.209.

The test methods, which have been used, are based on ANSI C63.4: 2003.

Radiated emission tests above 30 MHz were performed at a measurement distance of 3 meters.

Radiated emission tests below 30 MHz were performed at a measurement distance of 3 meters.

To calculate the field strength level from these results to the appropriate distance at which the limit is specified, the appropriate extrapolation factor is used.

The receivers are switching automatically to the right bandwidth in accordance with CISPR 16. This is implemented in the receiver. The antenna factors are programmed in the test receiver. The receiver automatically calculates the appropriate correction factor for the utilized antenna and also the appropriate antenna factor for the cable loss. The total correction is automatically added to the measured value.

1.5 Test facility.

The Federal Communications Commission and Industry Canada has reviewed the technical characteristics of the test facilities at TÜV Rheinland EPS B.V., located in Niekerk, 9822 TL Smidshornerweg 18, The Netherlands, and has found these test facilities to be in compliance with the requirements of 47 CFR Part 15, section 2.948(10-1-06 edition).

The description of the test facilities has been filed at the Office of the Federal Communications Commission under registration number 90828. The facility has been added to the list of laboratories performing these test services for the public on a fee basis.

The description of the test facilities has been filed to Industry Canada under registration number 2932G-1. The facility has been added to the list of laboratories performing these test services for the public on a fee basis.

1.6 Test conditions.

Normal test conditions:

Temperature (*)	: +15°C to +35°C
Relative humidity(*)	: 20 % to 75 %
Supply voltage	: 115VAC/60Hz to the AC/DC Power Supply
Air pressure	: 950 – 1050 hPa

When is was impracticable to carry out the tests under these conditions, a note to this effect stating the ambient temperature and relative humidity during the tests are stated separately.

2 System test configuration.

2.1 Justification.

The system was configured for testing in a typical fashion as a customer would normally use it.

The justification and manipulation of cables and equipment in order to simulate a worst-case behavior of the test setup has been carried out as prescribed in ANSI C63.4: 2003.

2.2 EUT mode of operation.

The EUT has been tested in passive(stand-by)- and active mode, i.e. the EUT is ready to detect a tag. To assess the behavior of the EUT while reading the tag, the EUT is tested with a tag presented such that it continuously reads the tag. The tests have been performed with a complete functioning EUT and interconnections.

2.3 Special accessories.

No special accessories are used and/or needed to achieve compliance.

2.4 Equipment modifications.

No modifications have been made to the equipment in order to achieve compliance.

2.5 Product Labeling

The product labeling information is available in the technical documentation package.

2.6 Block diagram of the EUT.

The block diagram is available in the technical documentation package.

2.7 Schematics of the EUT.

The schematics are available in the technical documentation package.

2.8 Part list of the EUT.

The part list is available in the technical documentation package.

3 Radiated emission data.

3.1 Radiated field strength measurements (frequency range of 0.009-30 MHz, H-field).

Frequency (MHz)	(a) Measurement results (dB μ V)	Detector	(b) Antenna factor	(c) Cable loss	(d) Distance Extrapolation factor	Measurement results (calculated a+b+c-d)	Limits
	3 meters		dB	dB	dB	dB(μ V)/m	dB(μ V)/m
0.120 fundamental	46.6	Av	20.1	1	80	-2.3	26 @300m
0.240	4.5	Av	20.1	1	80	-54.3	20 @300m
0.360	17.5	Av	20.0	1	80	-41.5	16.48 @300m
0.480	18.1	Av	20.0	1	80	-40.9	13.98 @300m
0.600	8.8	Qp	20.0	1	40	-10.2	12 @30m
0.720	0.4	Qp	20.0	1	40	-18.6	10.45 @30m
0.800	10	Qp	19.6	1	40	-9.4	29.5 @30m
0.920	10	Qp	19.6	1	40	-9.4	28.3 @30m
0.950	10	Qp	19.6	1	40	-9.4	28.0 @30m
1.000	10	Qp	19.6	1	40	-9.4	27.6 @30m
1.20 10 th harmonic	10	Av	19.7	1	40	-9.3	26 @30m

Table 1 Radiated emissions of the EUT

The results of the radiated emission tests in the frequency range 0.009 – 30 MHz, carried out in accordance with 47 CFR Part 15 section 15.209 with the EUT operating in continuous transmit mode, are depicted in table 1.

Notes:

1. Calculated measurement results are obtained by using the 80dB/decade factor (antenna factor and cable loss is included). i.e at 120 kHz:46.6 dBuV + 20.1dB + 1dB - 80dB= -2.3 dBuV/m.
2. A resolution bandwidth of 9kHz was used during testing
3. n.i. Indicates that no field strength values could be measured on the listed frequencies or in the listed frequency range. N.m. means not measured.
4. Field strength values of radiated emissions at frequencies not listed in table 1 are more than 20 dB below the applicable limit
5. The loop antenna was varied in horizontal and vertical orientations and also around it's axis. The reported value is the worst case found at the reported frequency.
6. The EUT was tested in horizontal and vertical orientations but showed no difference between these orientations. Worst case values noted.
7. The EUT was tested in both normal mode (i.e. without a tag in its proximity) and in activated mode (i.e. with a tag in its proximity).
8. Measurement uncertainty is ± 5.0 dB
9. Up to the 10th harmonic is tested. From 0.800 MHz up to 1.20 MHz only noise could be measured.

Test engineer

Signature : 

Name : R. van der Meer

Date : January 08, 2010

4 Conducted emission data.

4.1 Conducted emission data of the EUT

Frequency (MHz)	Measurement results dB(μV) Neutral		Measurement results dB(μV) Line 1		Limits dB(μV)		Result
	QP	AV	QP	AV	QP	AV	
0.150	31	29	30	29	66.0	56.0	PASS
0.368	9	8	10	9	58.5	48.5	PASS
0.482	19.5	19.1	15	15	56.3	46.3	PASS
5.2	22	21	21	20	60	50	PASS
13.56	50.6	45.7	50.1	45.5	60	50	PASS
27.12	14	4	10	9	60	50	PASS

Table 2 Conducted emission measurements.

The results of the conducted emission tests in the range of 150 kHz up to 30 MHz, carried out in accordance with 47 CFR Part 15 section 15.207 at the 115 Volts AC mains connection terminals of the AC/DC power supply which was connected to the EUT, are depicted in table 3. The EUT was tested in both passive and active mode (while detecting a tag). Maximum values recorded. The system is tested as in whole, so with all equipment as shown in Photo 1 in place and functioning. Being the worst case situation.

Notes:

1. Measurement uncertainty is ± 3.5 dB
2. The resolution bandwidth used was 9 kHz.
3. Values of conducted emissions at frequencies not listed in table 2 are more than 20 dB below the applicable limit.

Test engineer

Signature : 

Name : R. van der Meer

Date : November 09, 2009

5 Plot of the emission.

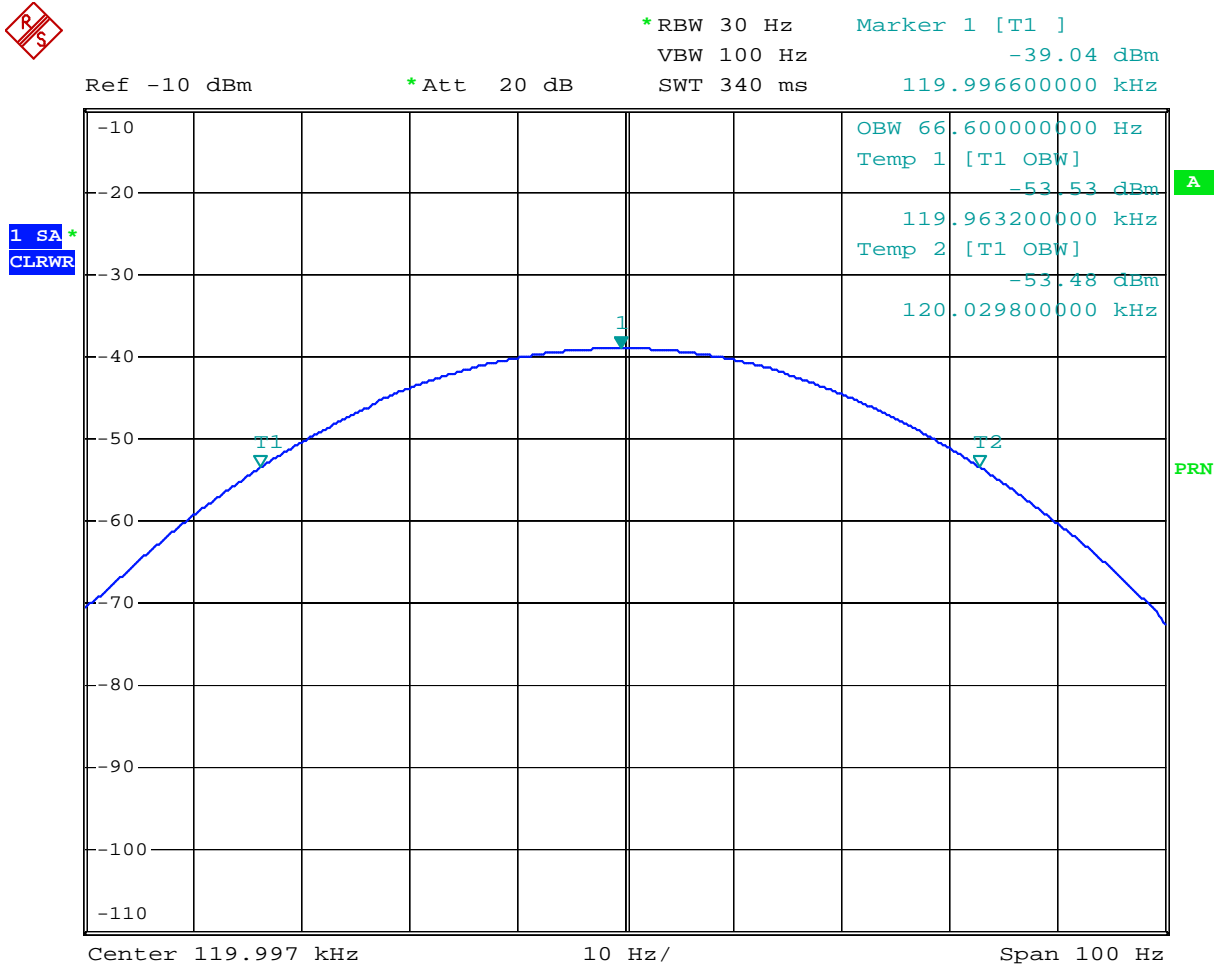

Date: 13.JAN.2010 10:08:55

Plot of the emission

6 List of utilized test equipment.

Inventory number	Description	Brand	Model	Last cal.	Next cal.
12512	LISN	EMCO	3625/2	01/2008	01/2010
15453	Active loopant. 60 cm	Chase	HLA6120	05/2009	05/2010
99069	Coax 5m RG213 OATS	NMi Certin B.V.	CABLE 5M OATS	12/2008	12/2010
99071	Coax OATS ground	NMi Certin B.V.	CABLE OATS	12/2008	12/2010
99107	Controller OATS	Heinrich Deisel	4630-100	NA	NA
99538	Spectrum analyzer	R&S	FSP	04/2009	04/2010
99547	Temperature-Humiditymeter	Europe supplies	WS-7082	10/2009	10/2010
99580	OATS	Comtest	FCC listed: 90828	08/2008	08/2011
99651	Variac	NA	Vast Activa: 08-9510	NA	NA
99699	Measuring receiver	R&S	ESCI	12/2008	12/2010

NA= Not Applicable