



Test Report No:
2350790R-RFUSV01S-C

TEST REPORT

FCC Rules&Regulations

Product Name	VX3 HD Outdoor Camera
Brand Name	resideo
Model No.	CAMWE-WO
FCC ID	CFS8DLCAMWEWO1
Applicant's Name / Address	Ademco Inc. 2 Corporate Center Drive, Suite 100, Melville, New York 11747, United States
Manufacturer's Name / Address	XAVi Technologies Corporation 22 F., No. 69, Sec. 2, Guangfu Rd., Sanchong Dist., New Taipei City 241561, Taiwan (R.O.C.)
Test Method Requested, Standard	FCC CFR Title 47 Part 15 Subpart C Section 15.247 ANSI C63.10-2013
Verdict Summary	IN COMPLIANCE
Documented By	<i>Amelia Wu</i> Amelia Wu
Approved By	<i>Rueyyan Lin</i> Rueyyan Lin
Date of Receipt	May 29, 2023
Date of Issue	Aug. 31, 2023
Report Version	V1.0

INDEX

	page
Competences and Guarantees.....	4
General Conditions.....	4
Revision History.....	5
Summary of Test Result.....	6
Comments and Remarks.....	6
1. General Information.....	7
1.1. EUT Description.....	7
1.2. EUT Information.....	7
1.3. Testing Applied Standards.....	8
1.4. Testing Location Information.....	8
1.5. Measurement Uncertainty.....	9
1.6. List of Test Equipment.....	10
2. Test Configuration of EUT.....	11
2.1. Test Condition.....	11
2.2. Test Channel Mode.....	11
2.3. Duty Cycle.....	12
2.4. The Worst Case Measurement Configuration.....	13
2.5. Tested System Details.....	14
2.6. Configuration of Tested System.....	14
3. AC Power Line Conducted Emission.....	16
3.1. Test Setup.....	16
3.2. Test Limit.....	16
3.3. Test Procedure.....	16
3.4. Test Result of AC Power Line Conducted Emission.....	16
4. Occupied Bandwidth & DTS Bandwidth.....	17
4.1. Test Setup.....	17
4.2. Test Limit.....	17
4.3. Test Procedures.....	17
4.4. Test Result of Occupied Bandwidth & DTS Bandwidth.....	17
5. Maximum Conducted Output Power.....	18
5.1. Test Setup.....	18
5.2. Test Limit.....	18
5.3. Test Procedures.....	18
5.4. Test Result of Maximum Conducted Output Power.....	18
6. Maximum Power Spectral Density.....	19
6.1. Test Setup.....	19

6.2.	Test Limit	19
6.3.	Test Procedures.....	19
6.4.	Test Result of Maximum Power Spectral Density	19
7.	Antenna Port Conducted Emission	20
7.1.	Test Setup.....	20
7.2.	Test Limit	20
7.3.	Test Procedure	20
7.4.	Test Result of Antenna Port Conducted Emission	20
8.	Transmitter Radiated Spurious Emission.....	21
8.1.	Test Setup.....	21
8.2.	Test Limit	22
8.3.	Test Procedure	22
8.4.	Test Result of Transmitter Radiated Spurious Emission	22
Appendix A. Test Result of AC Power Line Conducted Emission		
Appendix B. Test Result of Occupied Bandwidth & DTS Bandwidth		
Appendix C. Test Result of Maximum Conducted Output Power		
Appendix D. Test Result of Maximum Power Spectral Density		
Appendix E. Test Result of Antenna Port Conducted Emission		
Appendix F. Test Result of Transmitter Radiated Spurious Emission		
Appendix G. Test Setup Photograph		

Competences and Guarantees

DEKRA is a testing laboratory competent to carry out the tests described in this report.

In order to assure the traceability to other national and international laboratories, DEKRA has a calibration and maintenance program for its measurement equipment.

DEKRA guarantees the reliability of the data presented in this report, which is the result of the measurements and the tests performed to the item under test on the date and under the conditions stated in the report and it is based on the knowledge and technical facilities available at DEKRA at the time of performance of the test.

DEKRA is liable to the client for the maintenance of the confidentiality of all information related to the item under test and the results of the test.

The results presented in this Test Report apply only to the particular item under test established in this document.

IMPORTANT: No parts of this report may be reproduced or quoted out of context, in any form or by any means, except in full, without the previous written permission of DEKRA.

General Conditions

1. The test results relate only to the samples tested.
2. The test results shown in the test report are traceable to the national/international standard through the calibration report of the equipment and evaluated measurement uncertainty herein.
3. This report must not be used to claim product endorsement by TAF or any agency of the government.
4. The test report shall not be reproduced without the written approval of DEKRA Testing and Certification Co., Ltd.
5. Measurement uncertainties evaluated for each testing system and associated connections are given here to provide the system information for reference. Compliance determinations do not take into account measurement uncertainties for each testing system, but are based on the results of the compliance measurement.

Revision History

Version	Description	Issued Date
V1.0	Initial issue of report	Aug. 31, 2023

Summary of Test Result

Report Clause	Test Items	Result (PASS/FAIL)	Remark
3	AC Power Line Conducted Emission	PASS	-
4	Occupied Bandwidth & DTS Bandwidth	PASS	-
5	Maximum Conducted Output Power	PASS	-
6	Maximum Power Spectral Density	PASS	-
7	Antenna Port Conducted Emission	PASS	-
8	Transmitter Radiated Spurious Emission	PASS	-

Comments and Explanations

The declared of product specification for EUT presented in the report are provided by the manufacturer, and the manufacturer takes all the responsibilities for the accuracy of product specification.

Comments and Remarks

The product specification and testing instructions for the EUT declared in the report are provided by the manufacturer who will take all responsibilities for the accuracy.

1. General Information

1.1. EUT Description

Frequency Range	2400 ~ 2483.5 MHz
Operating Frequency	1 Mbps: 2402 ~ 2480 MHz 2 Mbps: 2402 ~ 2480 MHz
Channel Number	1 Mbps: 40 Channels 2 Mbps: 40 Channels
Type of Modulation	GFSK

Accessories Information				
No.	Equipment Name	Brand Name	Model No.	Rating
1	SWITCHING POWER SUPPLY (Adapter)	KLEC	KL-WA120100-E	INPUT: 100-240V, 50/60Hz 0.5A OUTPUT: 12.0V, 1.0A

Antenna Information				
Ant.	Brand Name	Model No.	Type	Gain (dBi)
0	LYNwave	ALX18M052AA3	Embedded	1.80

1.2. EUT Information

EUT Power Type	From Adapter / PoE			
EUT Function	<input checked="" type="checkbox"/>	Point-to-multipoint	<input type="checkbox"/>	Point-to-point

1.3. Testing Applied Standards

According to the specifications of the manufacturer, the EUT must comply with the requirements of the following standards:

- ◆ 47 CFR FCC Part 15
- ◆ ANSI C63.10-2013

The following reference test guidance is not within the scope of accreditation of TAF:

- ◆ KDB 558074 D01 v05r02
- ◆ KDB 414788 D01 v01r01

1.4. Testing Location Information

Testing Location Information		
Test Laboratory : DEKRA Testing and Certification Co., Ltd.		
1 (TAF: 3024)	ADD: No.372-2, Sec. 4, Zhongxing Rd., Zhudong Township, Hsinchu County 31061, Taiwan, R.O.C. TEL: +886-3-582-8001 FAX: +886-3-582-8958	
2 (TAF: 3024)	ADD: No.372, Sec. 4, Zhongxing Rd., Zhudong Township, Hsinchu County 31061, Taiwan, R.O.C. TEL: +886-3-582-8001 FAX: +886-3-582-8958	
Test site number for address 1 includes HC-SR02. Test site number for address 2 includes HC-CB02, HC-CB03, HC-CB04, HC-SR10 and HC-SR12.		

Test Condition	Test Site No.	Test Engineer	Test Environment (°C / %)	Test Date
AC Conduction Emission	HC-SR02	Igor Tseng	23 / 58	2023/06/08
RF Conducted Emission	HC-SR12	Clemens Fang	23 / 64	2023/06/06
Radiated Emission	HC-CB04	Scott Chang Gary Liao	22~21.5 / 55~59	2023/06/05~2023/06/09

1.5. Measurement Uncertainty

Uncertainties have been calculated according to the DEKRA internal document with the emissions test results be included in the report. The measurement uncertainties given below are based on a 95% confidence level (based on a coverage factor (k=2)).

Test item	Uncertainty
AC Power Line Conducted Emission	± 2.34 dB
Occupied Bandwidth & DTS Bandwidth	± 282.55 Hz
Maximum Conducted Output Power	± 1.16 dB
Maximum Power Spectral Density	± 2.47 dB
Antenna Port Conducted Emission	± 2.47 dB
Transmitter Radiated Spurious Emission	± 3.52 dB below 1 GHz ± 3.56 dB above 1 GHz

1.6. List of Test Equipment

HC-SR02

Instrument	Manufacturer	Model No.	Serial No.	Characteristics	Cal. Date	Next Cal. Date
Artificial Mains Network	R&S	ENV4200	848411/010	9kHz-30MHz, 4line/100A	2022/12/19	2023/12/18
EMI Test Receiver	R&S	ESR3	102608	9 kHz - 3.6 GHz	2022/09/28	2023/09/27
Two-Line V-Network	R&S	ENV216	100096	9kHz-30MHz	2023/06/02	2024/06/01
Coaxial Cable(9 m)	Harbour	RG-400	HC-SR02	9 kHz-2500 MHz	2022/08/15	2023/08/14
EMI Testing System	AUDIX	e3 210616 dekra V9	HC-SR02	N/A	N/A	N/A

HC-SR12

Instrument	Manufacturer	Model No.	Serial No.	Characteristics	Cal. Date	Next Cal. Date
High Speed Peak Power Meter Dual Input	Anritsu	ML2496A	1602004	0.3-40 GHz	2022/11/02	2023/11/01
Pulse Power Sensor	Anritsu	MA2411B	1531043	0.3-40 GHz	2022/11/02	2023/11/01
Pulse Power Sensor	Anritsu	MA2411B	1531044	0.3-40 GHz	2022/11/02	2023/11/01
Signal & Spectrum Analyzer	R&S	FSV40	101869	10Hz-40GHz	2022/07/13	2023/07/12

HC-CB04

Instrument	Manufacturer	Model No.	Serial No.	Characteristics	Cal. Date	Next Cal. Date
Signal Analyzer	R&S	FSVA40	101455	10 Hz-40 GHz	2022/09/29	2023/09/28
Trilog Broadband Antenna	Schwarzbeck	VULB 9168	1209	30 MHz-2 GHz	2022/06/14	2023/06/13
Double Ridged Horn Antenna	RF SPIN	DRH18-E	211212A18E N	1G-18GHz	2022/11/15	2023/11/14
Horn Antenna	Schwarzbeck	BBHA 9170	203	18G-40GHz	2023/02/13	2024/02/12
Pre-Amplifier	EMCI	EMC01820I	980365	30M-8 GHz,20 dB	2023/04/07	2024/04/06
Pre-Amplifier	EMEC	EM01G18GA	060835	1-18 GHz,50 dB	2022/07/04	2023/07/03
Pre-Amplifier	DEKRA	AP-400C	201801231	18G-40 GHz,48 dB	2022/09/27	2023/09/26
Coaxial Cable(10m)	Suhner	SF102_SF104	HC-CB04	30M-18 GHz	2022/08/08	2023/08/07
Coaxial Cable(3m)	Suhner,Rosnol	SF102_UP0264	HC-CB04_1	18G-40 GHz	2022/08/14	2023/08/13
EMI Test Receiver	R&S	ESR7	102260	10 Hz-7 GHz	2022/12/01	2023/11/30
Magnetic Loop Antenna	Teseq	HLA 6121	44287	0.01-30 MHz	2022/10/21	2023/10/20
Radiated Software	AUDIX	e3 V9	HC-CB04_1	N/A	N/A	N/A

Note: All equipment upon which need to calibrated are with calibration period of 1 year.

2. Test Configuration of EUT

2.1. Test Condition

EUT Operational Condition	
Testing Voltage	AC 120V/60Hz

2.2. Test Channel Mode

Test Software	TeraTerm
---------------	----------

Modulation	Frequency (MHz)	Power Setting
GFSK (1 Mbps)	2402	Default
	2440	Default
	2480	Default
GFSK (2 Mbps)	2402	Default
	2440	Default
	2480	Default

2.3. Duty Cycle

Mode	On Time (ms)	On+Off Time (ms)	Duty Cycle (%)	Duty Factor (dB)	1/T Minimum VBW (kHz)
GFSK (1 Mbps)	2.130	2.510	84.86	0.71	0.469
GFSK (2 Mbps)	1.070	1.880	56.91	2.45	0.935

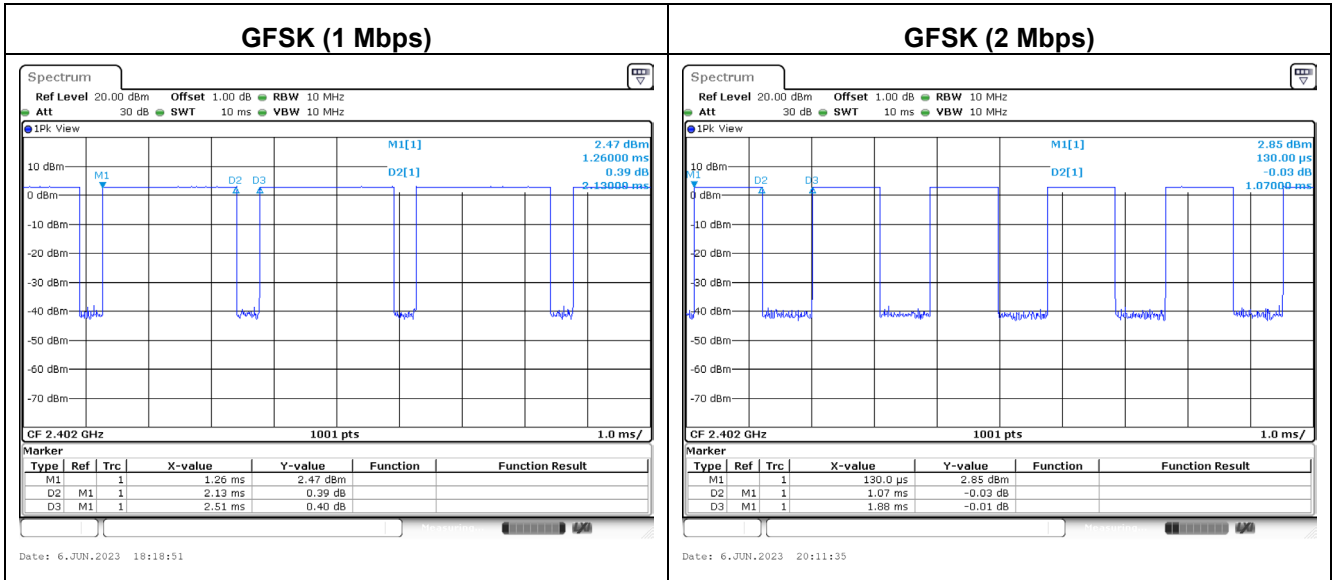

2.4. The Worst Case Measurement Configuration

Tests Item	AC Power Line Conducted Emission
Test Condition	AC power line conducted measurement for line and neutral
Operating Mode	Transmit
1	EUT + Adapter
2	EUT + PoE

Tests Item	Occupied Bandwidth & DTS Bandwidth Maximum Conducted Output Power Maximum Power Spectral Density Antenna Port Conducted Emission
Test Condition	Conducted measurement at transmit chains

Tests Item	Transmitter Radiated Spurious Emission
Test Condition	Radiated measurement If EUT consist of multiple antenna assembly (multiple antenna are used in EUT regardless of spatial multiplexing MIMO configuration), the radiated test should be performed with highest antenna gain of each antenna type.
Operating Mode < 1GHz	Transmit
1	EUT + Adapter
2	EUT + PoE
Operating Mode > 1GHz	Transmit

The EUT was performed at X axis, Y axis and Z axis position for transmitter radiated spurious emission test. The worst case was found at Z axis, so the measurement will follow this same test configuration.

Note:

1. Determining compliance shall be based on the results of the compliance measurement, not taking into account measurement instrumentation uncertainty.
2. For radiated emission below 1 GHz and AC power line conducted emission have performed all modes of operation were investigated and the worst-case emissions are reported.

2.5. Tested System Details

Mode 1: EUT + Adapter

No.	Equipment	Brand Name	Model No.	Serial No.	FCC ID
1	Notebook	DELL	Latitude E6320	8611271467	SDoC

Mode 2: EUT + PoE

No.	Equipment	Brand Name	Model No.	Serial No.	FCC ID
1	Notebook	DELL	Latitude E6320	8611271467	SDoC
2	PoE	BulletPoE	BPI100-H	2205190176	SDoC

2.6. Configuration of Tested System

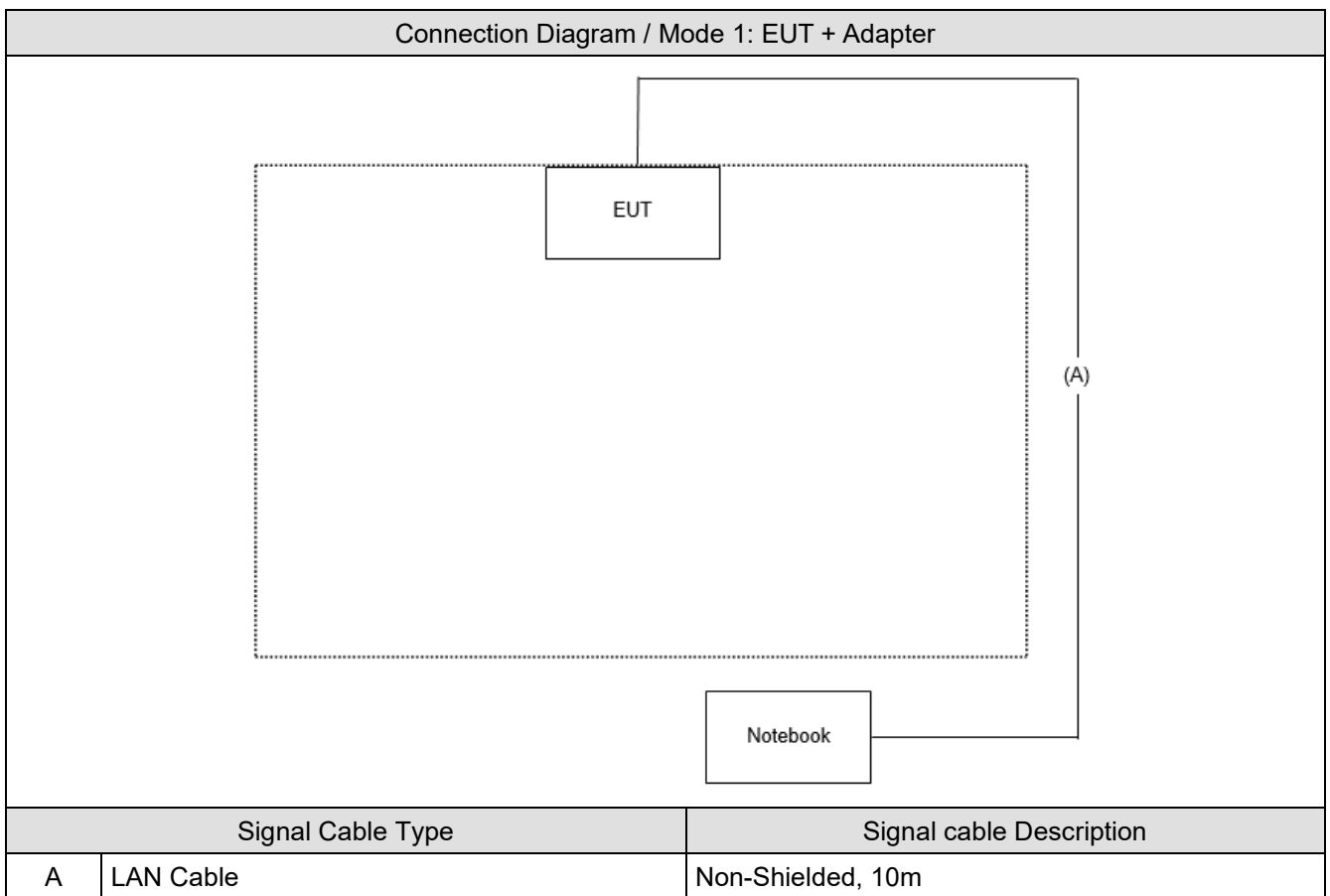

Connection Diagram / Mode 2: EUT + PoE

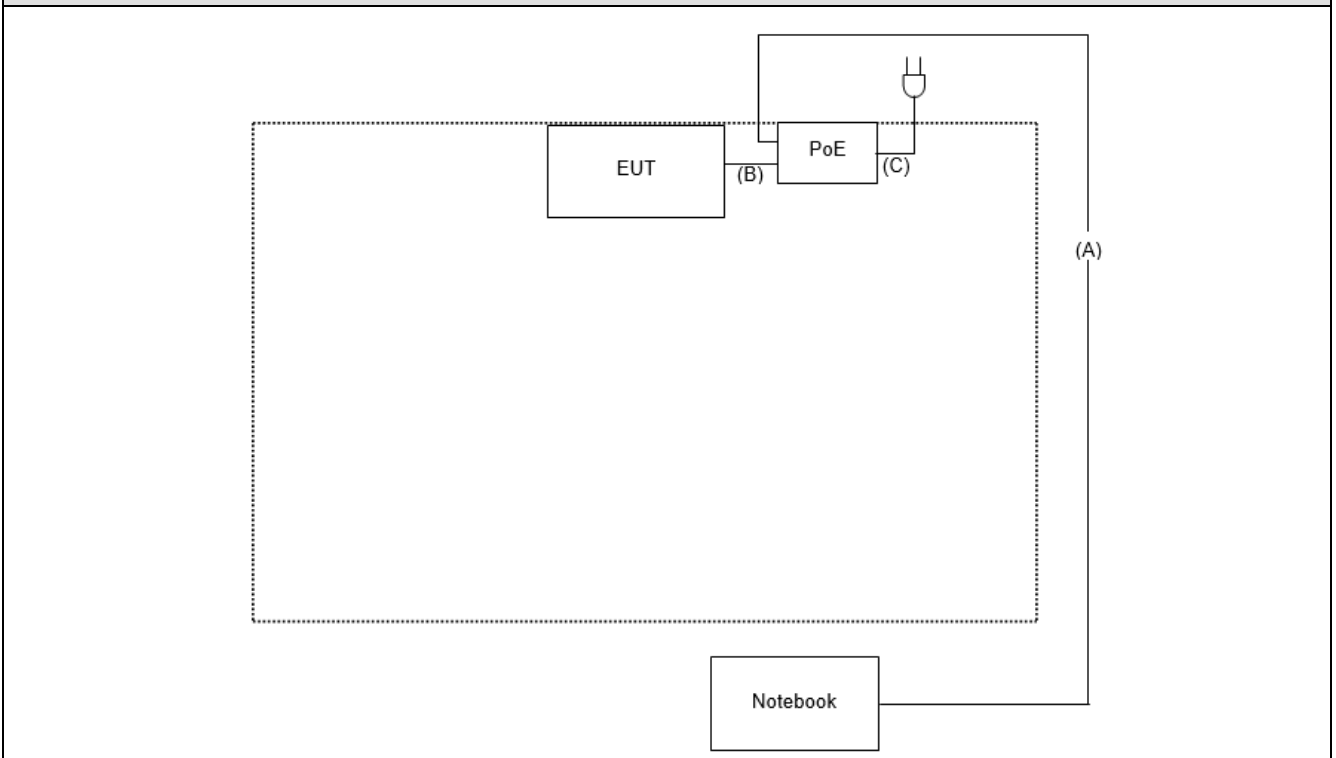

Signal Cable Type		Signal cable Description
A	LAN Cable	Non-Shielded, 10m
B	LAN Cable	Non-Shielded, 0.6m
C	Power Cable	Non-Shielded, 1.8m

3. AC Power Line Conducted Emission

3.1. Test Setup

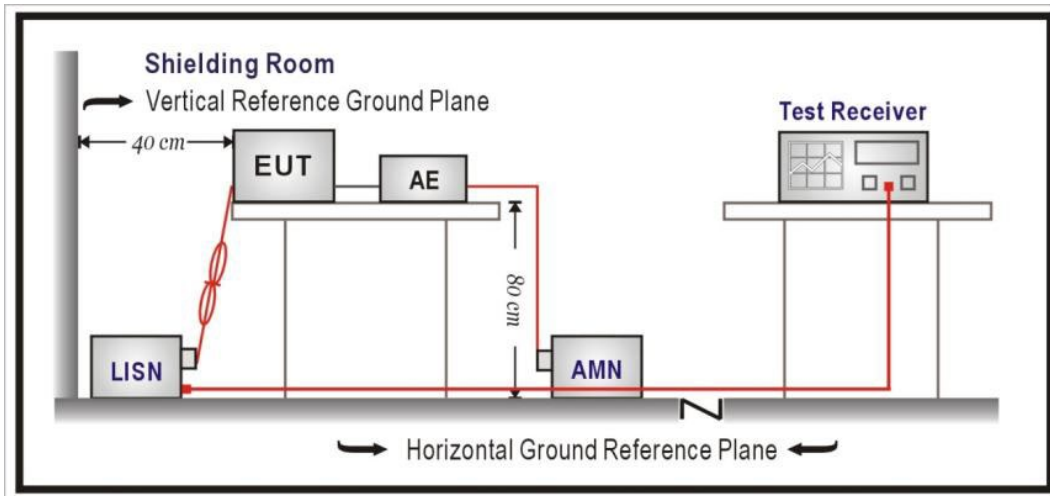

3.2. Test Limit

Frequency (MHz)	QP (dBuV)	AV (dBuV)
0.15 - 0.50	66 - 56	56 - 46
0.50 - 5.0	56	46
5.0 - 30	60	50

Remarks: In the above table, the tighter limit applies at the band edges.

3.3. Test Procedure

The EUT was setup according to ANSI C63.10: 2013 for AC Power Line Conducted Emissions.

3.4. Test Result of AC Power Line Conducted Emission

Refer as Appendix A

4. Occupied Bandwidth & DTS Bandwidth

4.1. Test Setup

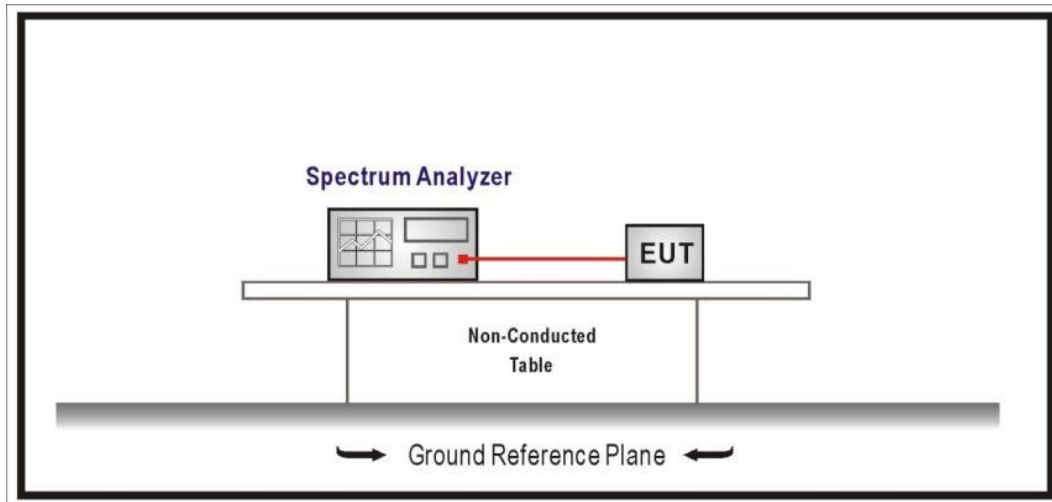

4.2. Test Limit

The 6 dB bandwidth: ≥ 500 kHz.

Occupied Bandwidth: N/A

4.3. Test Procedures

The EUT was setup according to ANSI C63.10: 2013; tested according to DTS test procedure of KDB 558074.

4.4. Test Result of Occupied Bandwidth & DTS Bandwidth

Refer as Appendix B

5. Maximum Conducted Output Power

5.1. Test Setup

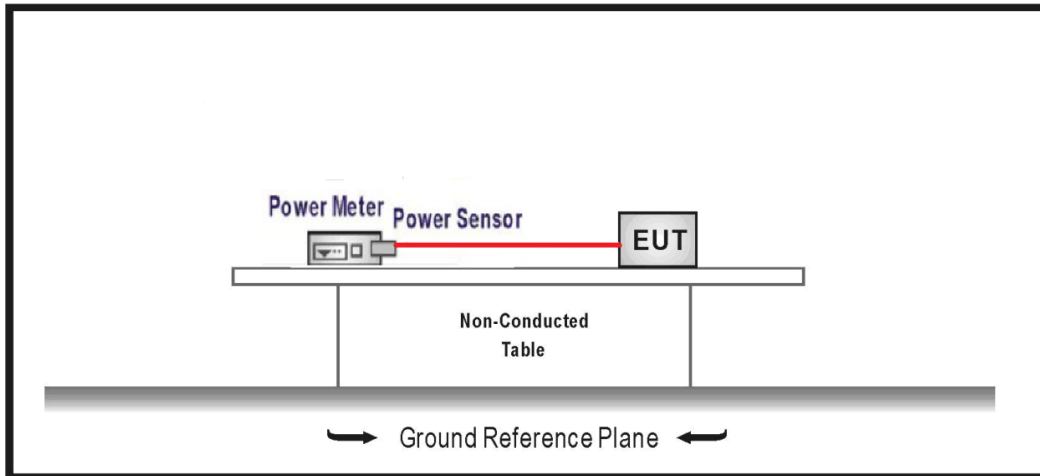

5.2. Test Limit

The Maximum Conducted Output Power shall be less 1 Watt.

5.3. Test Procedures

The EUT was setup according to ANSI C63.10: 2013; tested according to DTS test procedure of KDB 558074.

5.4. Test Result of Maximum Conducted Output Power

Refer as Appendix C

6. Maximum Power Spectral Density

6.1. Test Setup

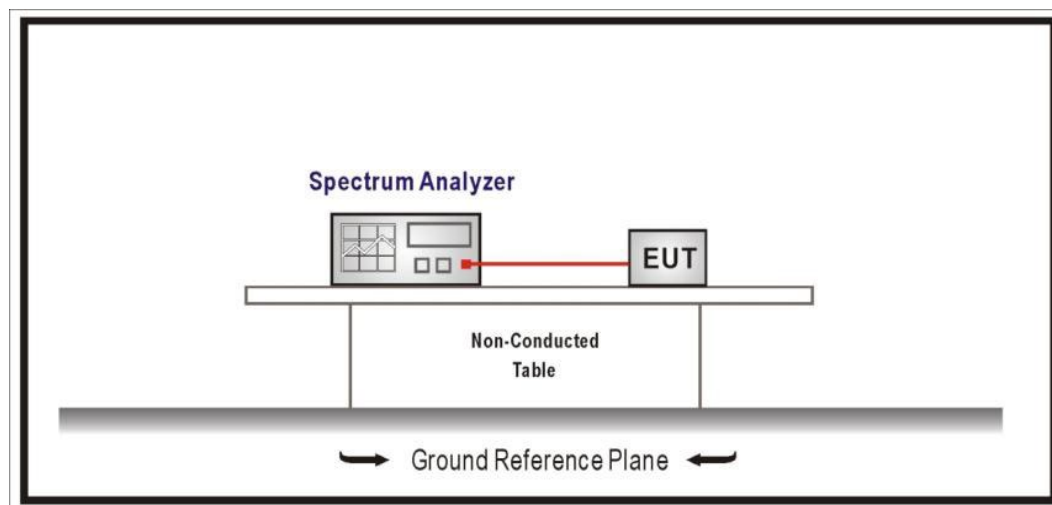

6.2. Test Limit

The peak power spectral density conducted from the intentional radiated to the antenna shall not be greater than +8 dBm in any 3 kHz band during any time interval of continuous transmission.

6.3. Test Procedures

The EUT was setup according to ANSI C63.10: 2013; tested according to DTS test procedure of KDB 558074.

6.4. Test Result of Maximum Power Spectral Density

Refer as Appendix D

7. Antenna Port Conducted Emission

7.1. Test Setup

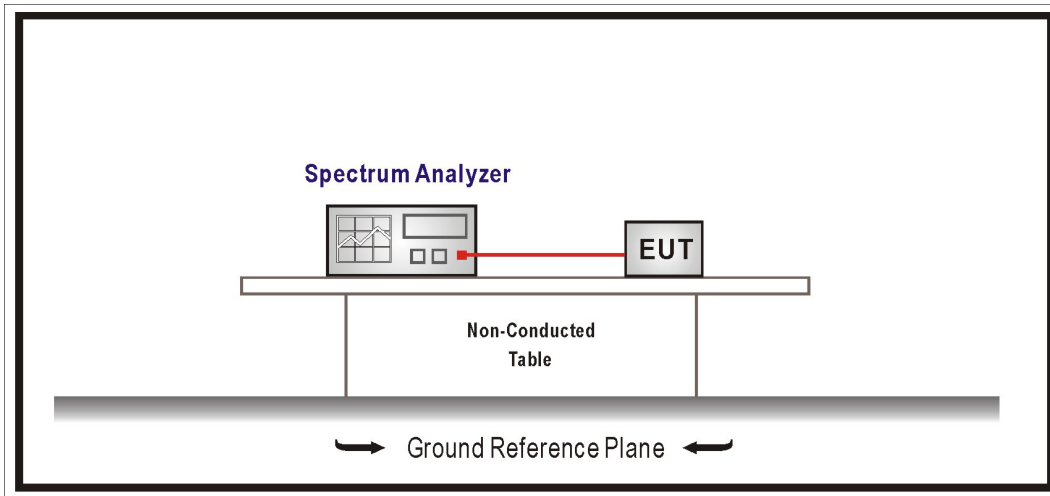

7.2. Test Limit

RF output power procedure	Limit (dBc)
Peak output power procedure	20
Average output power procedure	30

Remarks:

1. In any 100 kHz bandwidth outside the frequency band in which the spread spectrum or digitally modulated intentional radiator is operating, the radio frequency power that is produced by the intentional radiator shall be at least 20 dB below that in the 100 kHz bandwidth within the band that contains the highest level of the desired power, based on either an RF conducted or a radiated measurement, provided the transmitter demonstrates compliance with the peak conducted power limit.
2. If the transmitter complies with the conducted power limit based on the use of RMS averaging over a time interval, the attenuation required under this paragraph shall be 30 dB instead of 20 dB.

7.3. Test Procedure

The EUT was setup according to ANSI C63.10: 2013 and tested according to DTS test procedure of KDB 558074.

7.4. Test Result of Antenna Port Conducted Emission

Refer as Appendix E

8. Transmitter Radiated Spurious Emission

8.1. Test Setup

9 kHz ~ 30 MHz

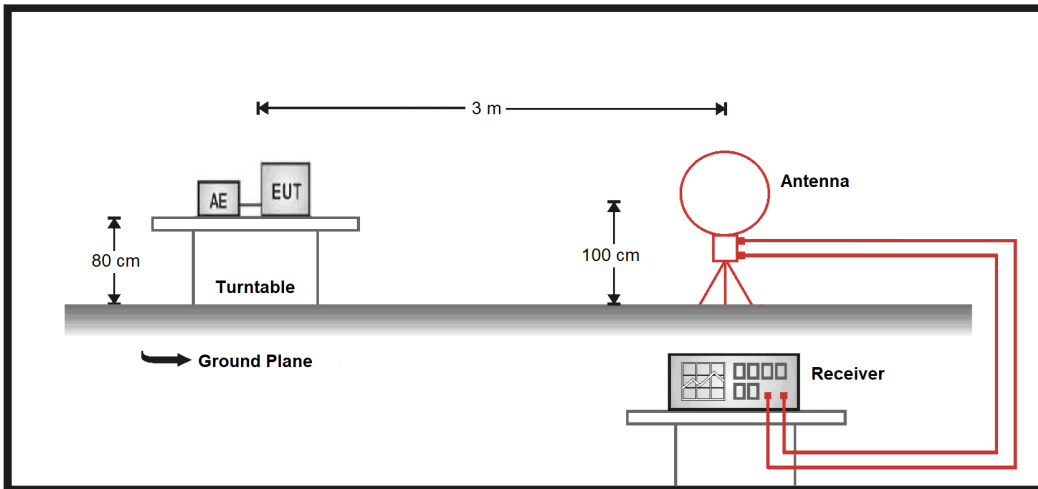

30 MHz ~ 1 GHz

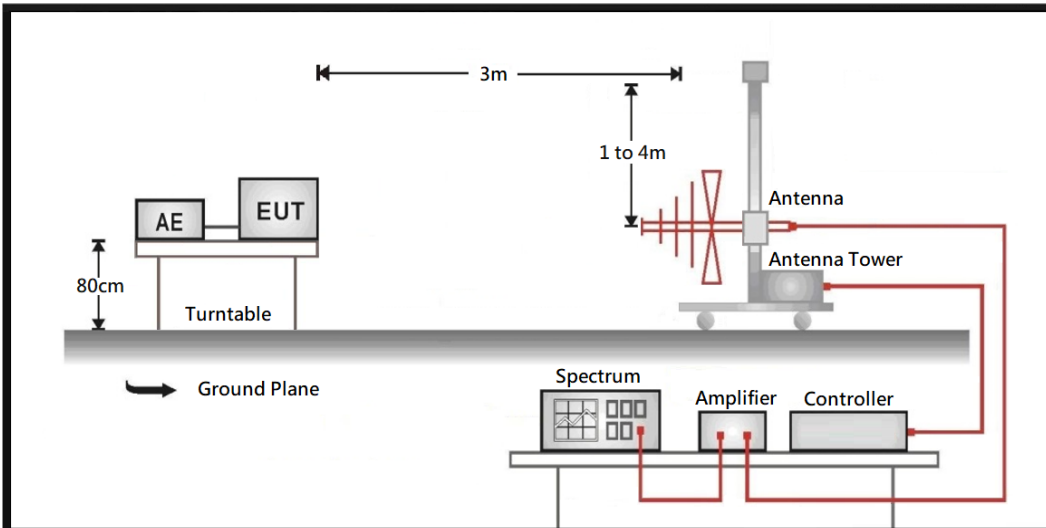

Above 1 GHz

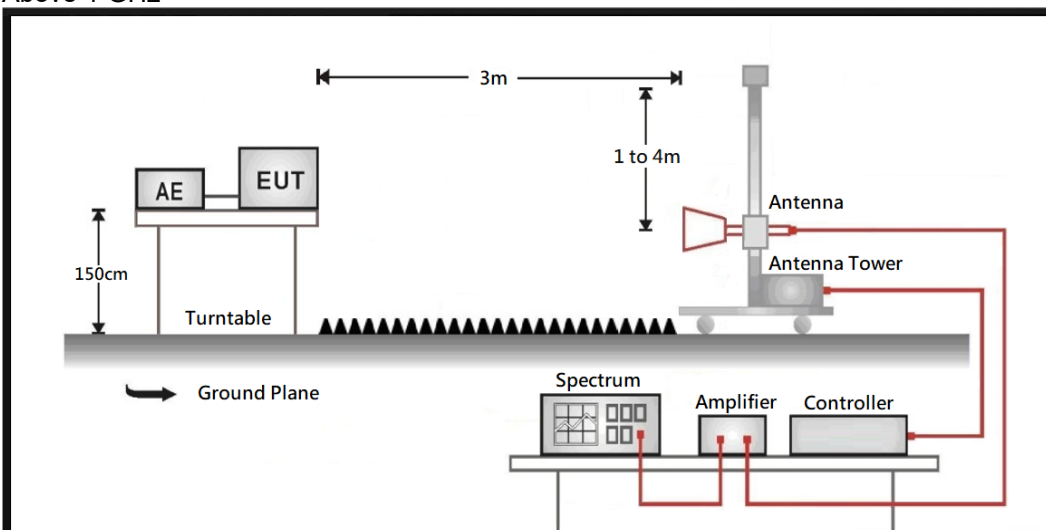

8.2. Test Limit

Frequency (MHz)	Field strength (uV/m)	Field strength (dBuV/m)	Measurement distance (m)
0.009 – 0.490	2400/F(kHz)	20 log (2400/F(kHz))	300
0.490 – 1.705	24000/F(kHz)	20 log (24000/F(kHz))	30
1.705 - 30	30	29.5	30
30 - 88	100	40	3
88 - 216	150	43.5	3
216 - 960	200	46	3
Above 960	500	54	3

Remarks:

1. Field strength (dBuV/m) = 20 log Field strength (uV/m)
2. In the Above Table, the tighter limit applies at the band edges.
3. Distance refers to the distance in meters between the measuring instrument antenna and the closed point of any part of the device or system.

8.3. Test Procedure

The EUT was setup according to ANSI C63.10: 2013 and tested according to DTS test procedure of KDB 558074.

The EUT and its simulators are placed on a turn table which is 0.8 or 1.5 meter above ground. The turn table can rotate 360 degrees to determine the position of the maximum emission level.

The antenna can move up and down between 1 meter and 4 meters to find out the maximum emission level.

Both horizontal and vertical polarization of the antenna are set on measurement. In order to find the maximum emission, all of the interface cables must be manipulated according to ANSI C63.10: 2013 on radiated measurement.

On any frequency or frequencies from 9 kHz(include The the lowest oscillator frequency generated within the device up to the 10th harmonic) to 1000 MHz, the limit shown are based on measuring equipment employing a quasi-peak detector function and on any frequency or frequencies above 1000 MHz the radiated limit shown are based upon the use of measurement instrumentation employing an average detector function. When average radiated emission measurement are included emission measurement below 1000 MHz, there also is a limit on the radio frequency emissions, as measured using instrumentation with a peak detector function, corresponding to 20 dB above the maximum permitted average limit.

The bandwidth below 1 GHz setting on the field strength meter is 120 kHz and above 1 GHz is 1 MHz.

8.4. Test Result of Transmitter Radiated Spurious Emission

Refer as Appendix F

Appendix A. Test Result of AC Power Line Conducted Emission

Test Mode	Mode 1: EUT + Adapter	Phase	Line
Test Condition	GFSK (2 Mbps) / 2480 MHz		

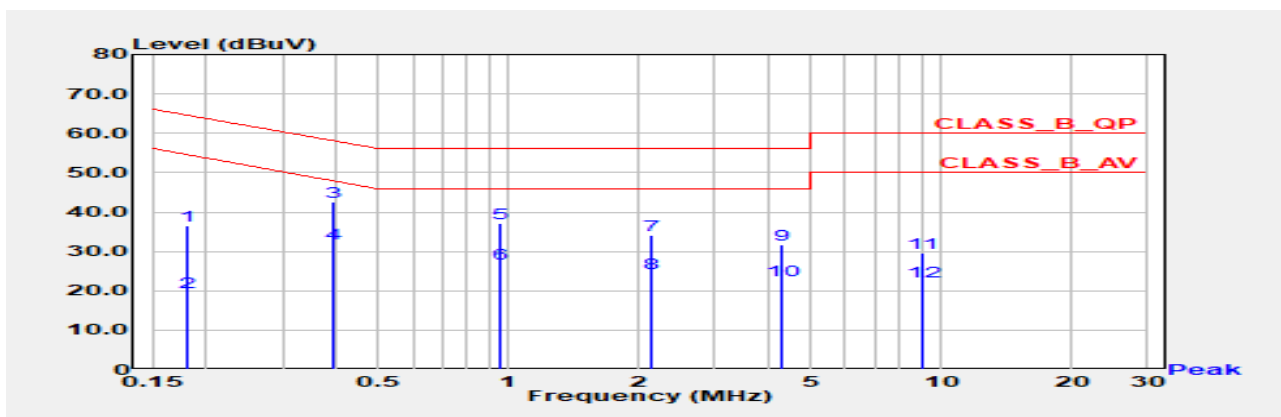

No	Frequency (MHz)	Emission Level (dBuV)	Limit (dBuV)	Margin (dB)	Reading Level (dBuV)	Correct Factor (dB)	Detector Type
1	0.181	36.62	64.42	-27.80	26.75	9.86	QP
2	0.181	19.76	54.42	-34.66	9.90	9.86	AV
*3	0.395	42.72	57.95	-15.24	32.84	9.88	QP
*4	0.395	31.99	47.95	-15.97	22.11	9.88	AV
5	0.951	37.26	56.00	-18.74	27.33	9.93	QP
6	0.951	26.82	46.00	-19.18	16.89	9.93	AV
7	2.125	34.11	56.00	-21.89	24.12	9.99	QP
8	2.125	24.34	46.00	-21.66	14.35	9.99	AV
9	4.274	31.79	56.00	-24.21	21.71	10.08	QP
10	4.274	22.75	46.00	-23.25	12.67	10.08	AV
11	9.026	29.66	60.00	-30.34	19.43	10.23	QP
12	9.026	22.48	50.00	-27.52	12.25	10.23	AV

Note:

1. "*" means this data is the worst emission level.
2. Emission Level = Reading Level + Correct Factor (Correct Factor = LISN Insertion Loss + Cable Loss).
3. Margin = Emission Level - Limit.

Test Mode	Mode 1: EUT + Adapter	Phase	Neutral
Test Condition	GFSK (2 Mbps) / 2480 MHz		

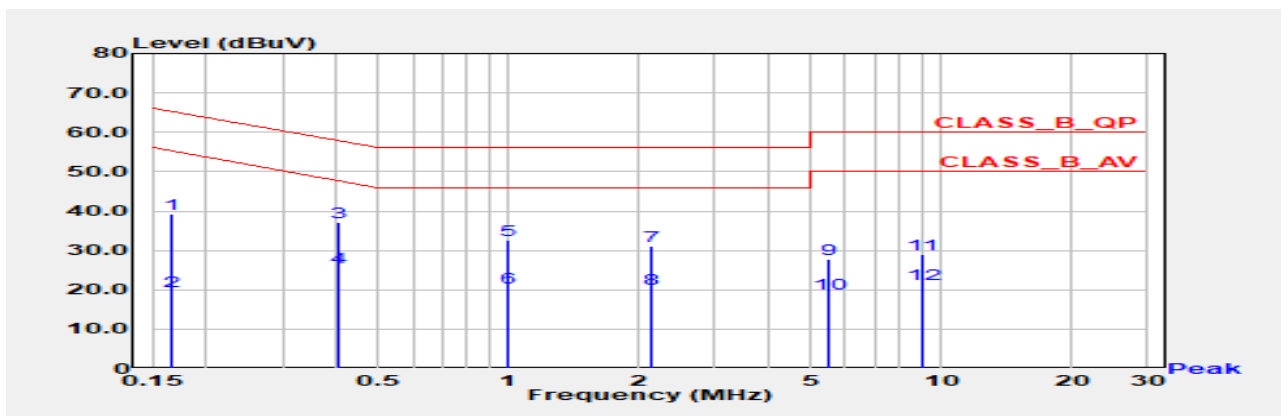

No	Frequency (MHz)	Emission Level (dBUV)	Limit (dBUV)	Margin (dB)	Reading Level (dBUV)	Correct Factor (dB)	Detector Type
1	0.166	39.19	65.17	-25.98	29.37	9.82	QP
2	0.166	19.72	55.17	-35.45	9.90	9.82	AV
*3	0.402	37.00	57.81	-20.82	27.12	9.87	QP
*4	0.402	25.52	47.81	-22.29	15.65	9.87	AV
5	0.991	32.62	56.00	-23.38	22.70	9.92	QP
6	0.991	20.51	46.00	-25.49	10.59	9.92	AV
7	2.123	30.99	56.00	-25.01	21.01	9.97	QP
8	2.123	20.14	46.00	-25.86	10.17	9.97	AV
9	5.496	27.64	60.00	-32.36	17.55	10.09	QP
10	5.496	18.91	50.00	-31.09	8.81	10.09	AV
11	9.053	29.05	60.00	-30.95	18.87	10.19	QP
12	9.053	21.52	50.00	-28.48	11.34	10.19	AV

Note:

1. "*" means this data is the worst emission level.
2. Emission Level = Reading Level + Correct Factor (Correct Factor = LISN Insertion Loss + Cable Loss).
3. Margin = Emission Level - Limit.

Test Mode	Mode 2: EUT + PoE	Phase	Line
Test Condition	GFSK (2 Mbps) / 2480 MHz		

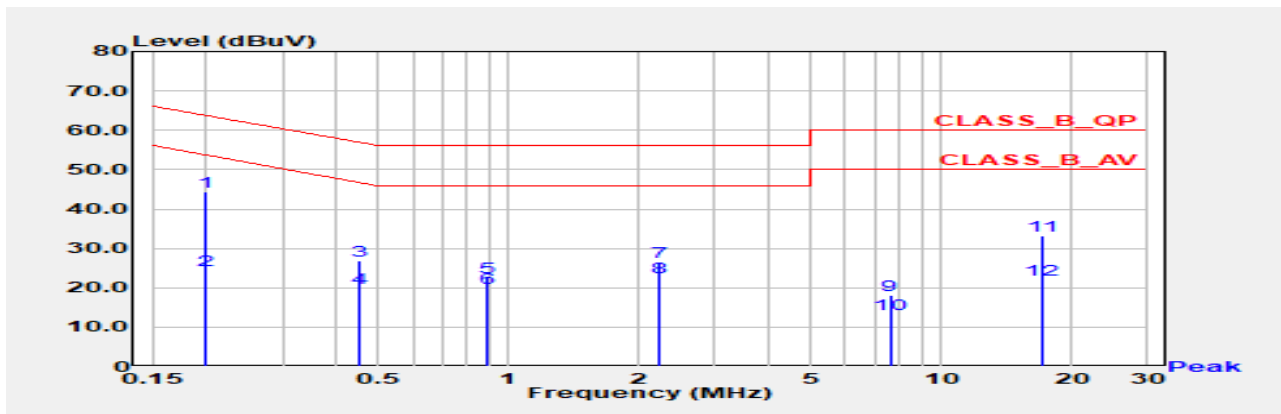

No	Frequency (MHz)	Emission Level (dBUV)	Limit (dBUV)	Margin (dB)	Reading Level (dBUV)	Correct Factor (dB)	Detector Type
*1	0.199	44.35	63.63	-19.28	34.48	9.87	QP
2	0.199	24.50	53.63	-29.13	14.62	9.87	AV
3	0.449	26.84	56.89	-30.05	16.95	9.89	QP
4	0.449	19.82	46.89	-27.06	9.94	9.89	AV
5	0.897	22.50	56.00	-33.50	12.58	9.92	QP
6	0.897	19.89	46.00	-26.11	9.97	9.92	AV
7	2.238	26.46	56.00	-29.54	16.47	9.99	QP
*8	2.238	22.78	46.00	-23.22	12.79	9.99	AV
9	7.611	18.02	60.00	-41.98	7.83	10.19	QP
10	7.611	13.40	50.00	-36.60	3.21	10.19	AV
11	17.016	33.25	60.00	-26.75	22.87	10.38	QP
12	17.016	21.98	50.00	-28.02	11.60	10.38	AV

Note:

1. "*" means this data is the worst emission level.
2. Emission Level = Reading Level + Correct Factor (Correct Factor = LISN Insertion Loss + Cable Loss).
3. Margin = Emission Level - Limit.

Test Mode	Mode 2: EUT + PoE	Phase	Neutral
Test Condition	GFSK (2 Mbps) / 2480 MHz		

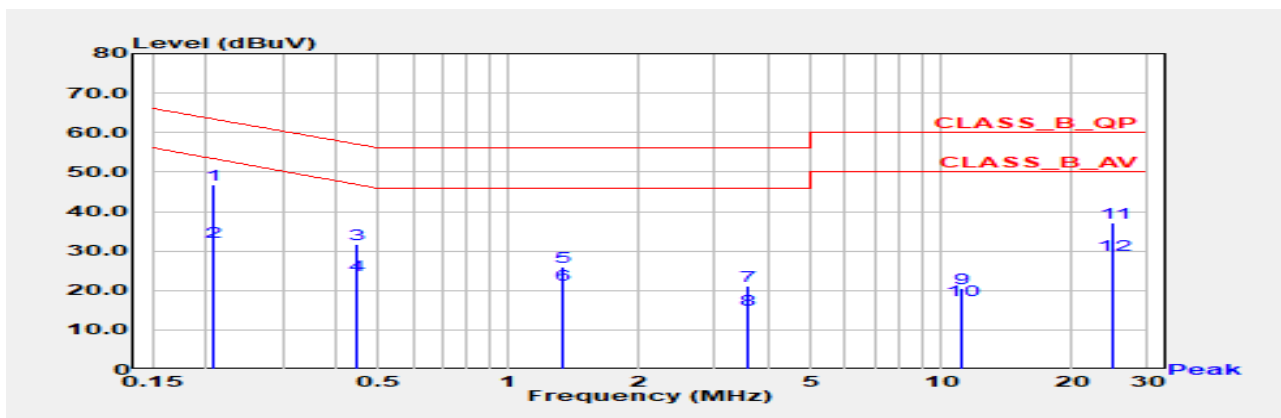

No	Frequency (MHz)	Emission Level (dBUV)	Limit (dBUV)	Margin (dB)	Reading Level (dBUV)	Correct Factor (dB)	Detector Type
*1	0.206	46.94	63.36	-16.41	37.09	9.85	QP
2	0.206	32.16	53.36	-21.20	22.30	9.85	AV
3	0.447	31.55	56.93	-25.38	21.67	9.88	QP
4	0.447	23.70	46.93	-23.23	13.82	9.88	AV
5	1.340	26.05	56.00	-29.95	16.12	9.94	QP
6	1.340	21.49	46.00	-24.51	11.56	9.94	AV
7	3.547	21.12	56.00	-34.88	11.09	10.03	QP
8	3.547	15.09	46.00	-30.91	5.07	10.03	AV
9	11.168	20.44	60.00	-39.56	10.22	10.22	QP
10	11.168	17.49	50.00	-32.51	7.27	10.22	AV
11	25.021	37.07	60.00	-22.93	26.65	10.42	QP
*12	25.021	28.95	50.00	-21.05	18.53	10.42	AV

Note:

1. "*" means this data is the worst emission level.
2. Emission Level = Reading Level + Correct Factor (Correct Factor = LISN Insertion Loss + Cable Loss).
3. Margin = Emission Level - Limit.

Appendix B.1 Test Result of Occupied Bandwidth

Modulation	Frequency (MHz)	Measure Level (MHz)	Limit (MHz)
GFSK (1 Mbps)	2402	1.018	-
	2440	1.018	-
	2480	1.023	-
GFSK (2 Mbps)	2402	2.037	-
	2440	2.037	-
	2480	2.037	-

GFSK (1 Mbps) / 2402 MHz

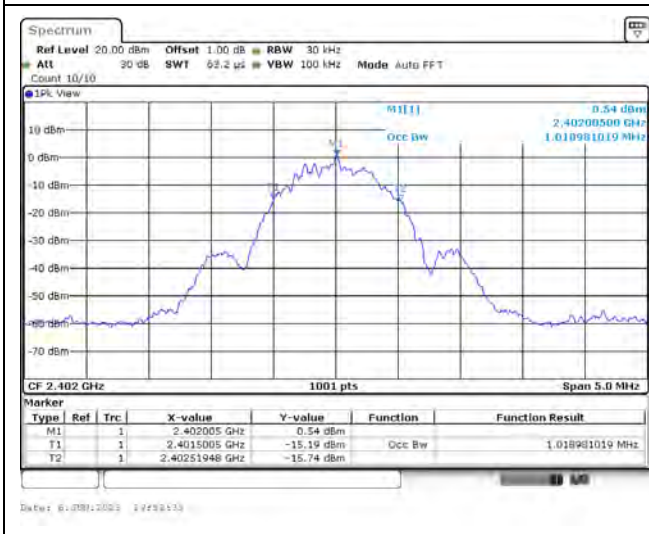

GFSK (1 Mbps) / 2440 MHz

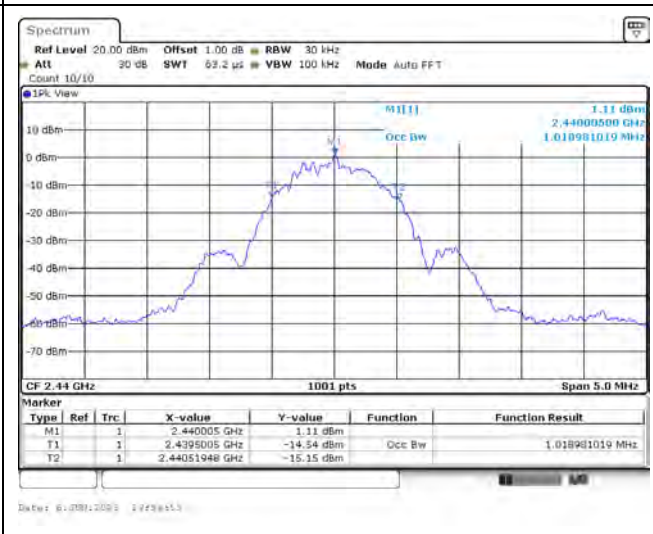

GFSK (1 Mbps) / 2480 MHz

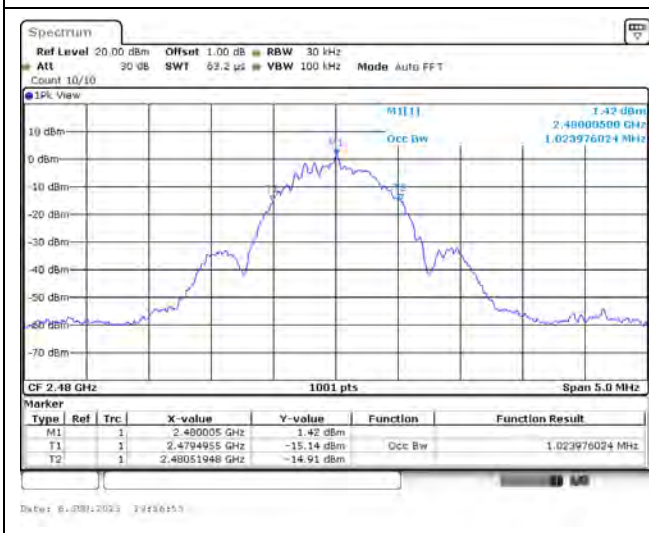

GFSK (2 Mbps) / 2402 MHz

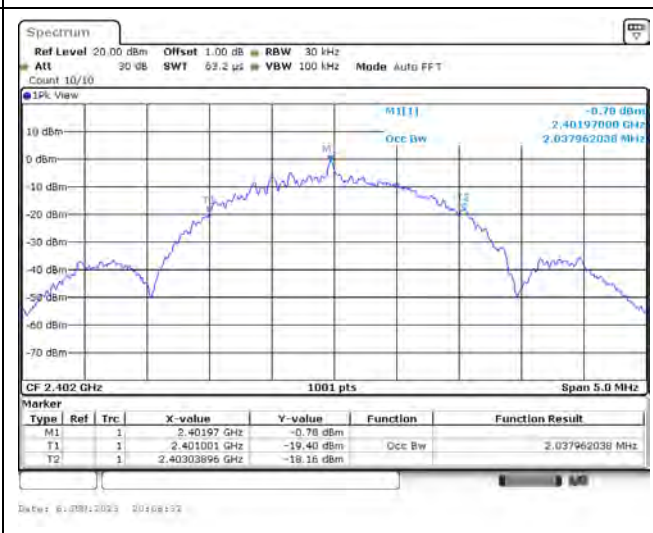

GFSK (2 Mbps) / 2440 MHz

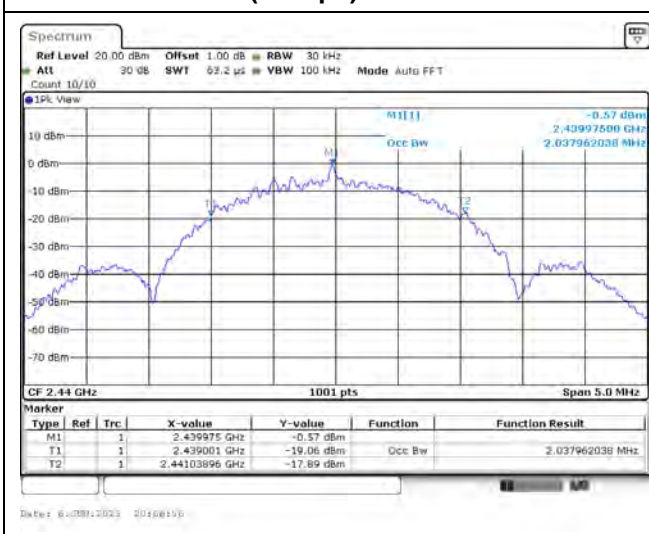

GFSK (2 Mbps) / 2480 MHz

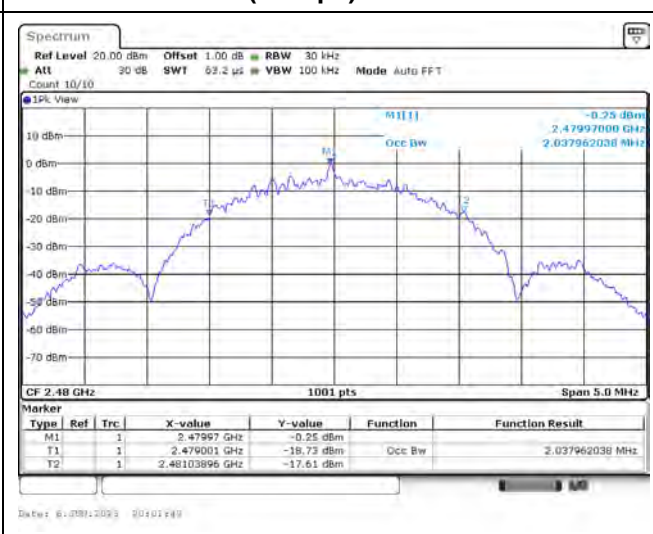

Appendix B.2 Test Result of DTS Bandwidth

Modulation	Frequency (MHz)	Measure Level (MHz)	Limit (MHz)	Result
GFSK (1 Mbps)	2402	0.654	≥ 0.500	Pass
	2440	0.654	≥ 0.500	Pass
	2480	0.654	≥ 0.500	Pass
GFSK (2 Mbps)	2402	1.113	≥ 0.500	Pass
	2440	1.108	≥ 0.500	Pass
	2480	1.113	≥ 0.500	Pass

GFSK (1 Mbps) / 2402 MHz

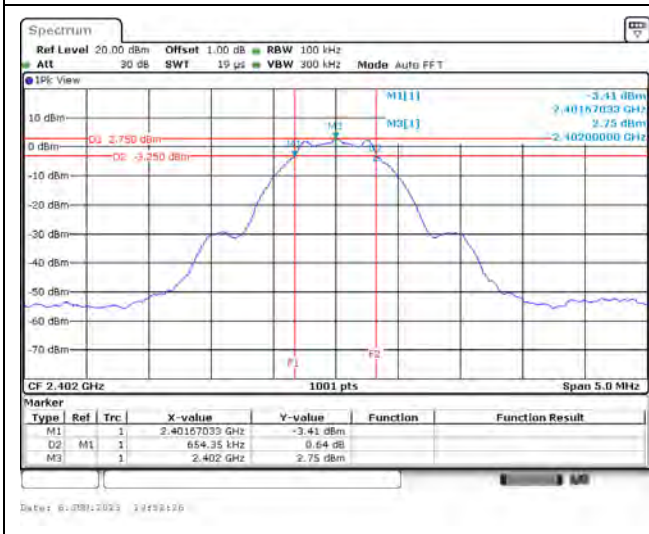

GFSK (1 Mbps) / 2440 MHz

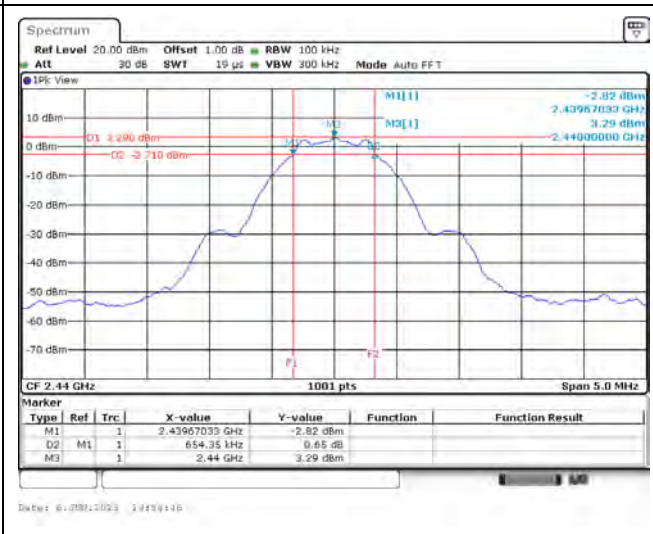

GFSK (1 Mbps) / 2480 MHz

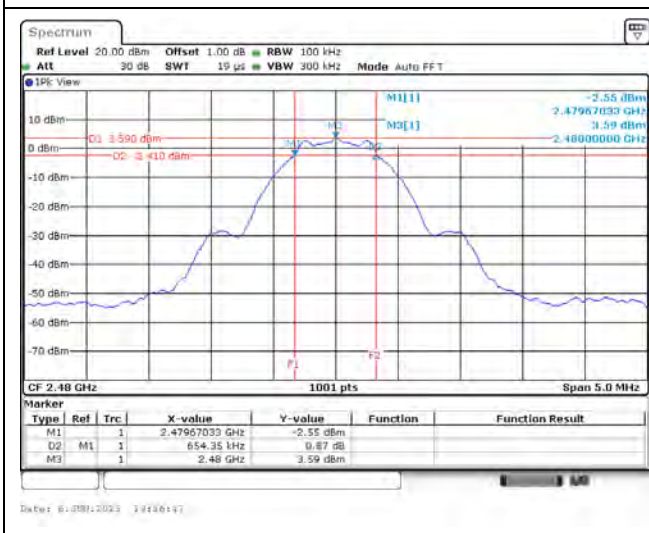

GFSK (2 Mbps) / 2402 MHz

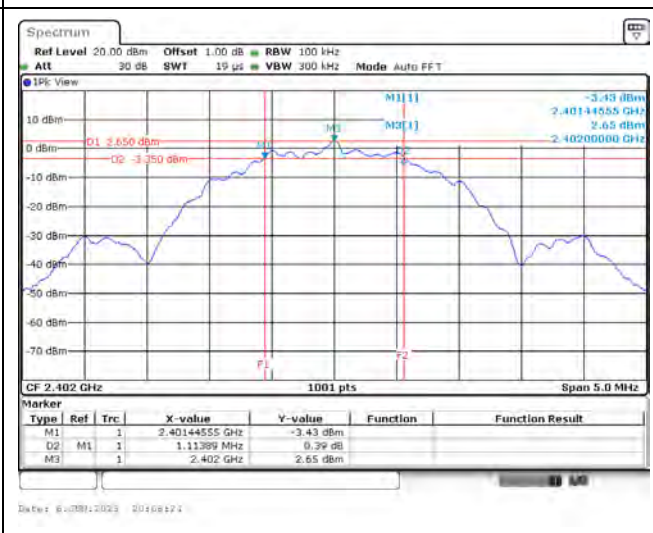

GFSK (2 Mbps) / 2440 MHz

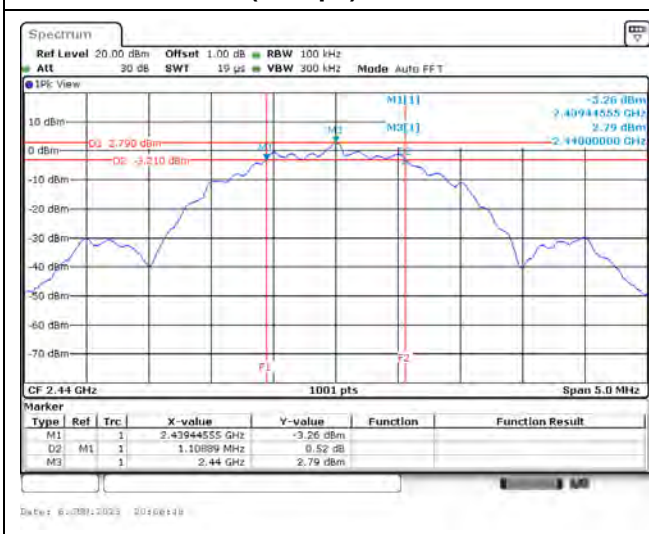

GFSK (2 Mbps) / 2480 MHz

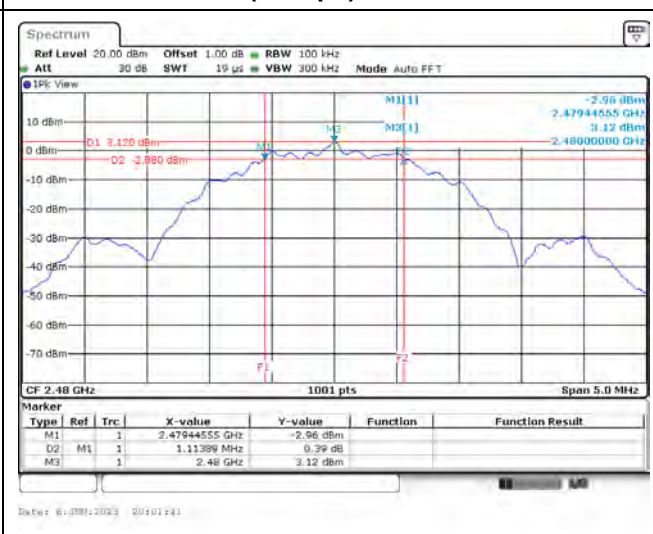

Appendix C. Test Result of Maximum Conducted Output Power

Modulation	Frequency (MHz)	Measure Level (dBm)	Limit (dBm)	Result
GFSK (1 Mbps)	2402	2.92	≤ 30.00	Pass
	2440	3.30	≤ 30.00	Pass
	2480	3.59	≤ 30.00	Pass
GFSK (2 Mbps)	2402	2.96	≤ 30.00	Pass
	2440	3.33	≤ 30.00	Pass
	2480	3.61	≤ 30.00	Pass

Appendix D. Test Result of Maximum Power Spectral Density

Modulation	Frequency (MHz)	Measure Value (dBm/3kHz)	Limit (dBm/3kHz)	Result
GFSK (1 Mbps)	2402	-13.130	≤ 8.000	Pass
	2440	-11.910	≤ 8.000	Pass
	2480	-12.680	≤ 8.000	Pass
GFSK (2 Mbps)	2402	-15.130	≤ 8.000	Pass
	2440	-15.220	≤ 8.000	Pass
	2480	-13.810	≤ 8.000	Pass

GFSK (1 Mbps) / 2402 MHz

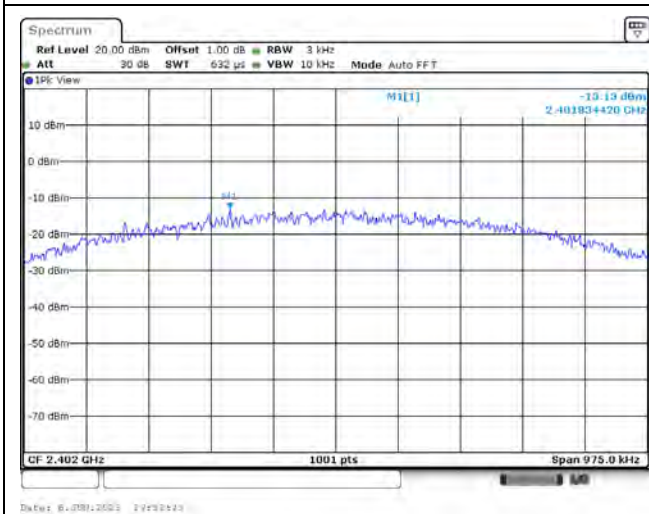

GFSK (1 Mbps) / 2440 MHz

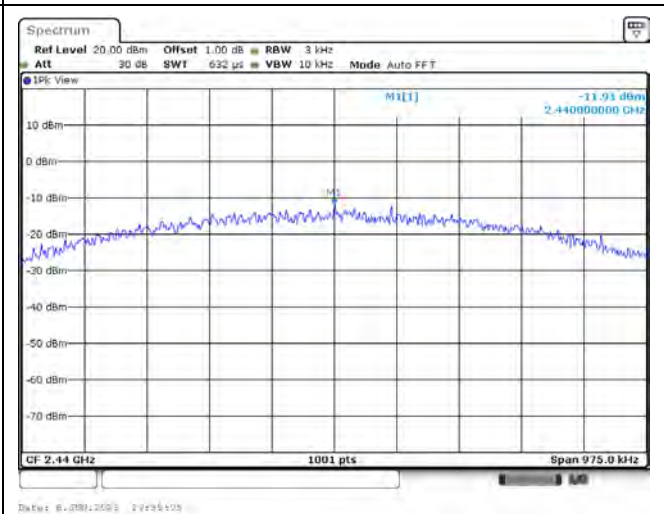

GFSK (1 Mbps) / 2480 MHz

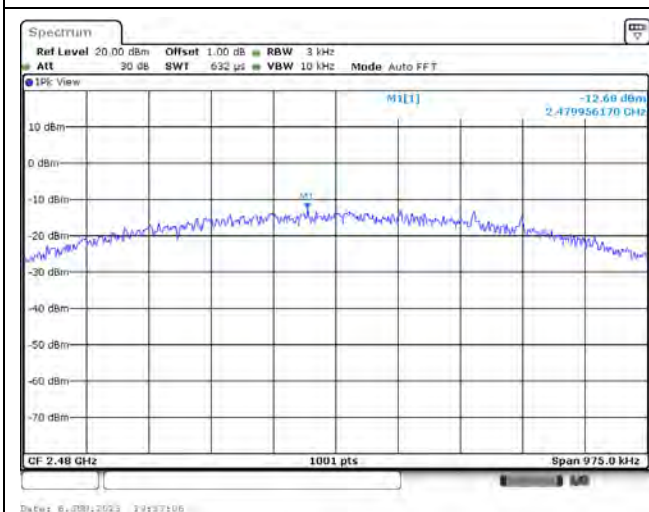

GFSK (2 Mbps) / 2402 MHz

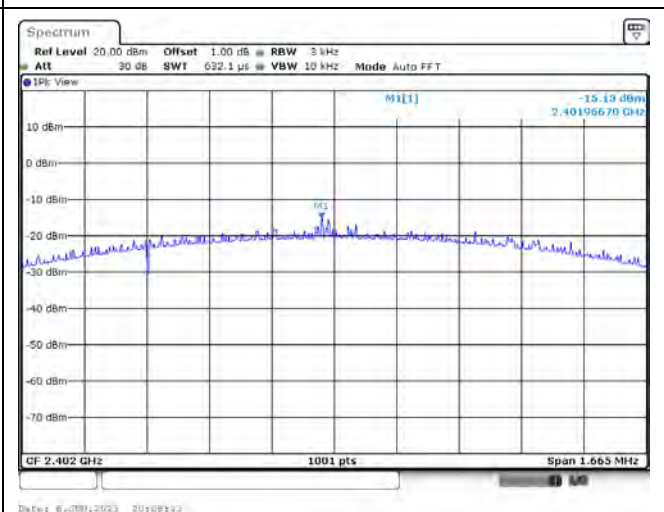

GFSK (2 Mbps) / 2440 MHz

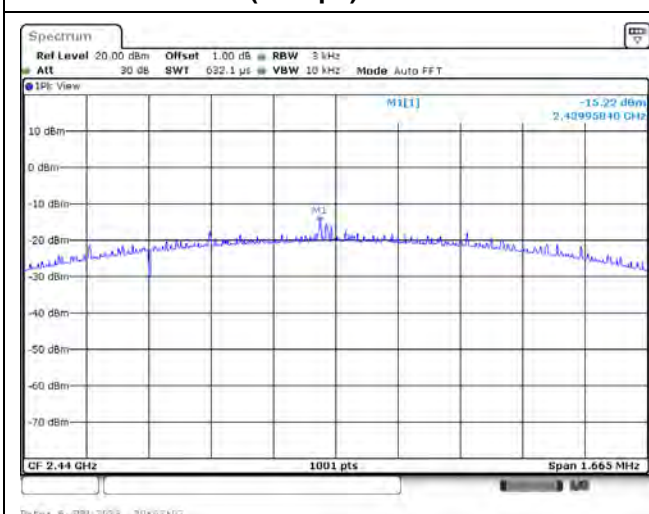

GFSK (2 Mbps) / 2480 MHz

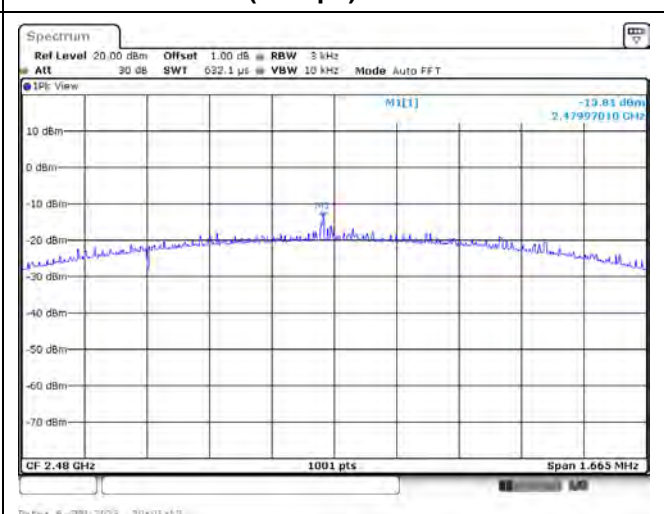

Appendix E. Test Result of Antenna Port Conducted Emission

GFSK (1 Mbps) / 2402 MHz

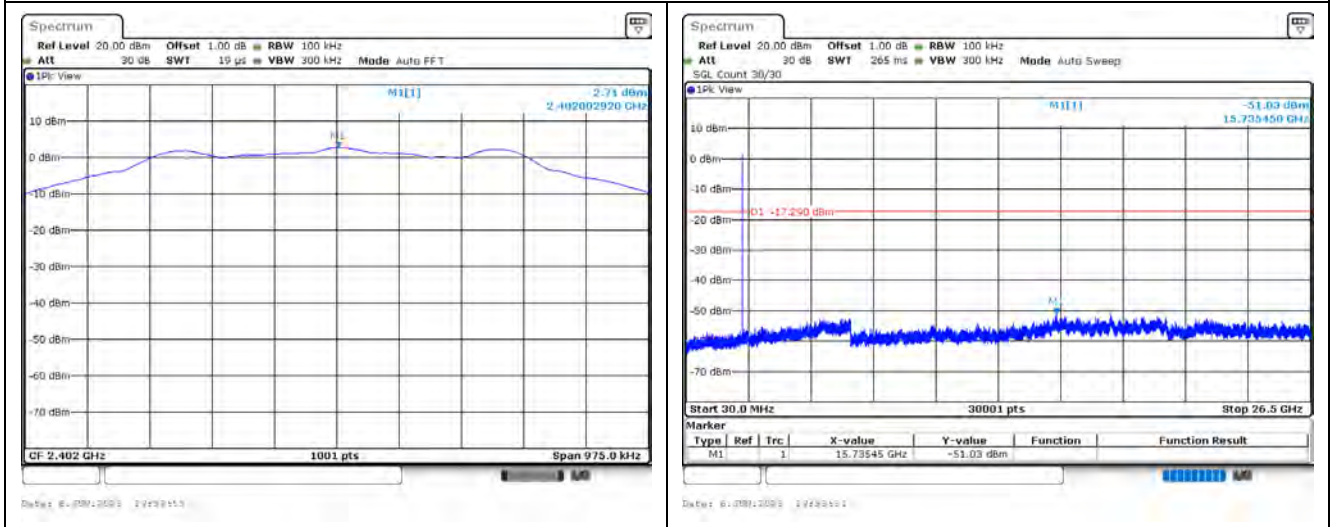

GFSK (1 Mbps) / 2440 MHz

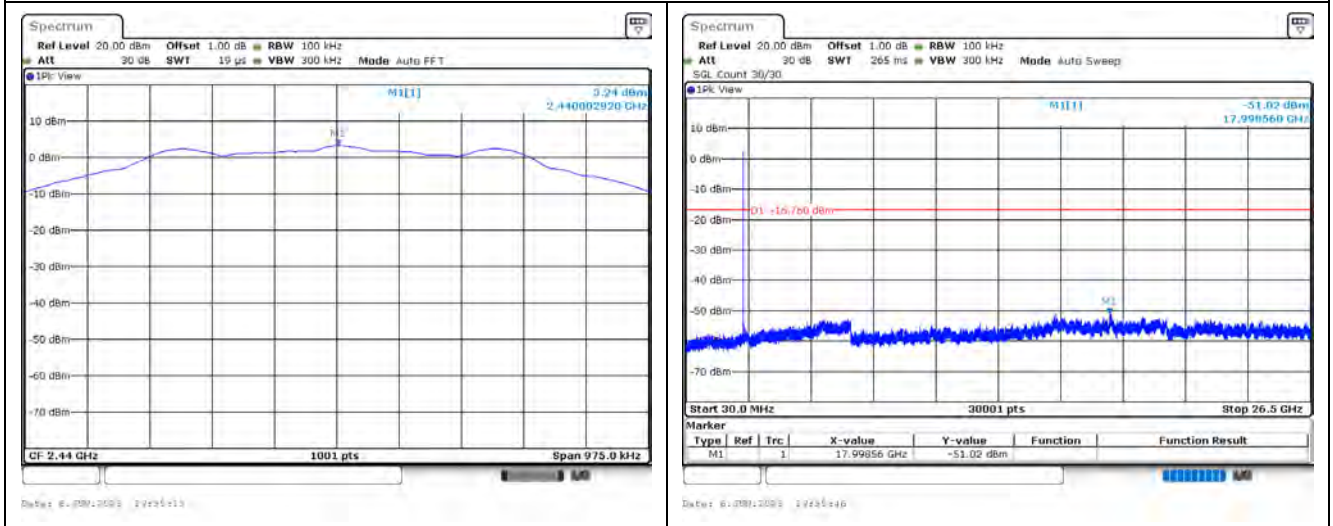

GFSK (1 Mbps) / 2480 MHz

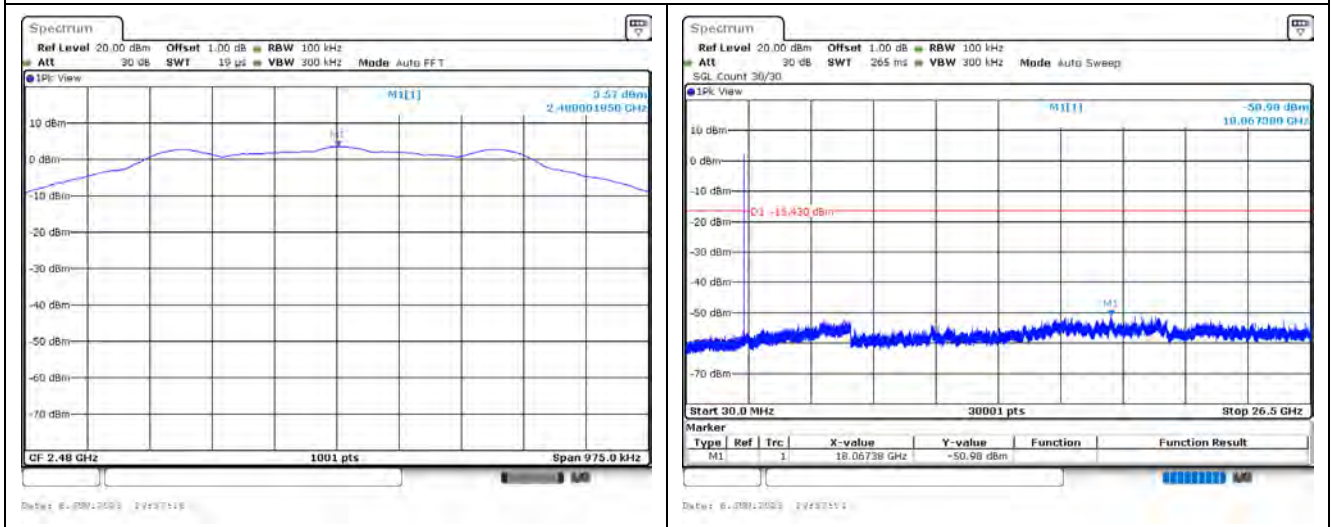

GFSK (2 Mbps) / 2402 MHz

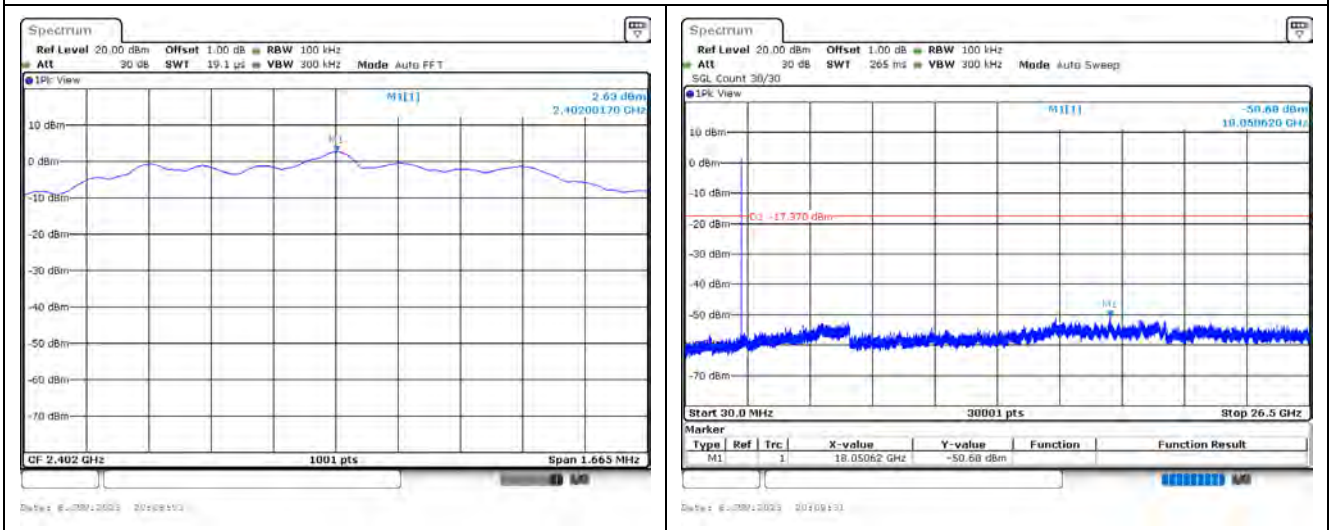

GFSK (2 Mbps) / 2440 MHz

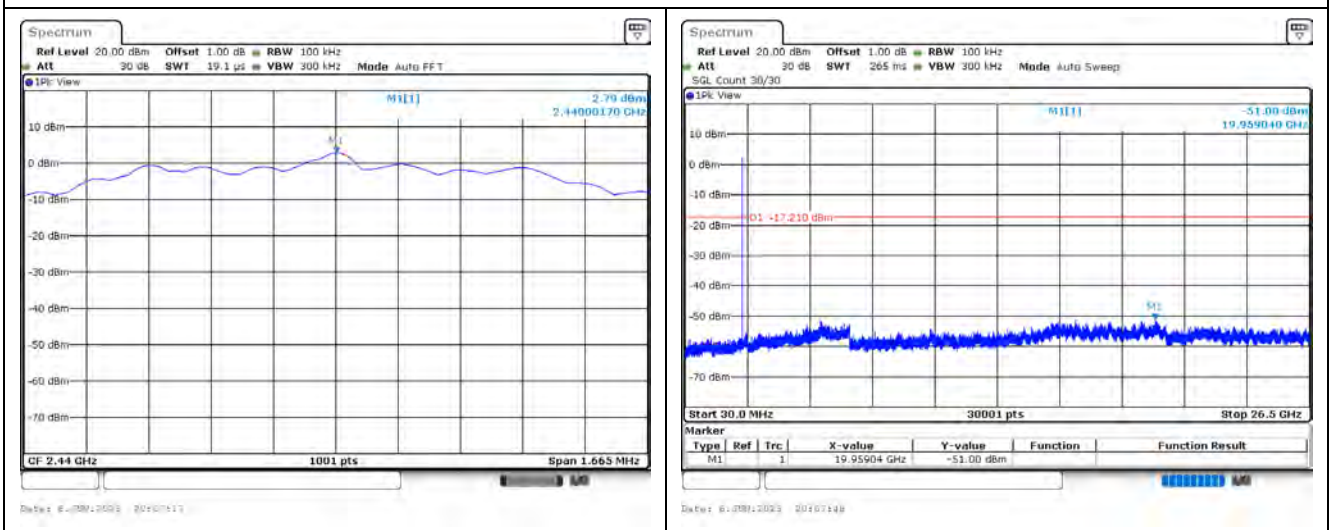

GFSK (2 Mbps) / 2480 MHz

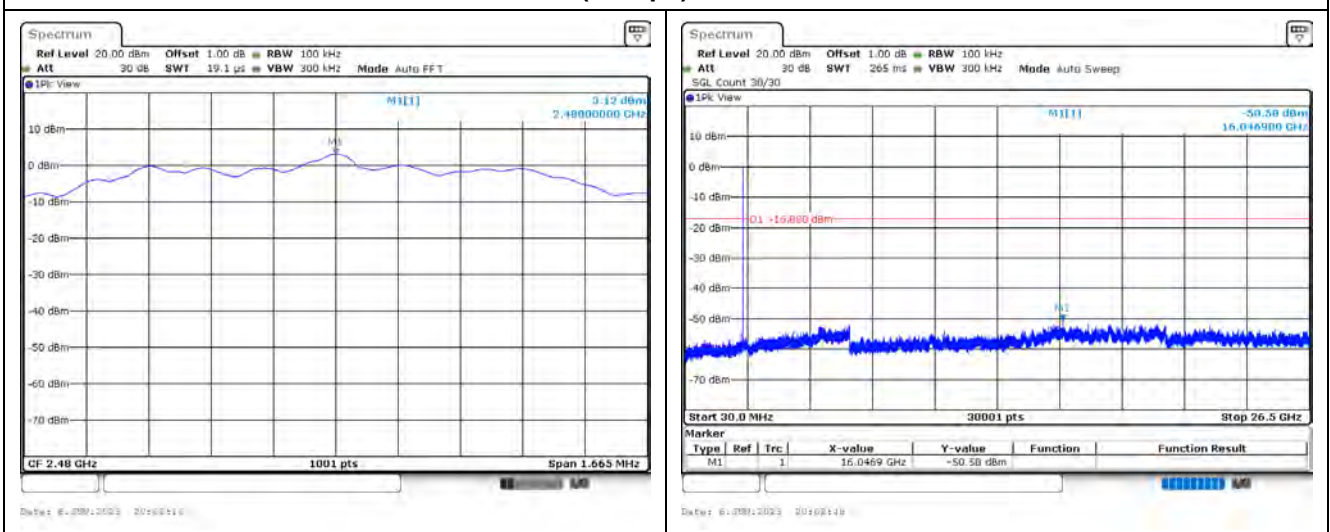

GFSK (1 Mbps) / 2402 MHz (Band Edge)

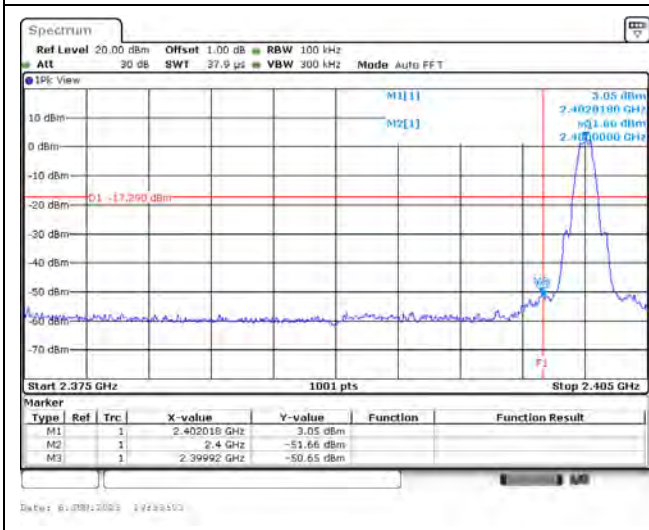

GFSK (1 Mbps) / 2480 MHz (Band Edge)

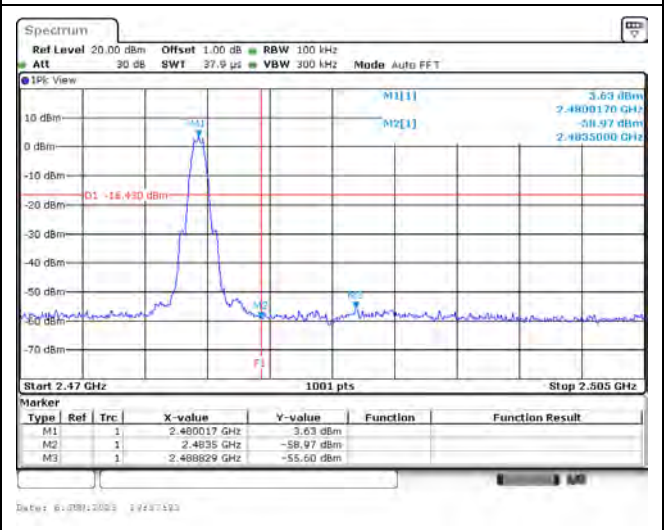

GFSK (2 Mbps) / 2402 MHz (Band Edge)

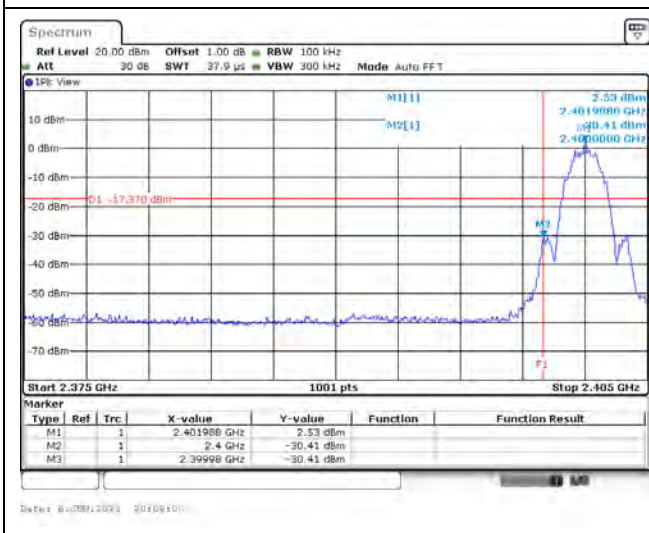

GFSK (2 Mbps) / 2480 MHz (Band Edge)

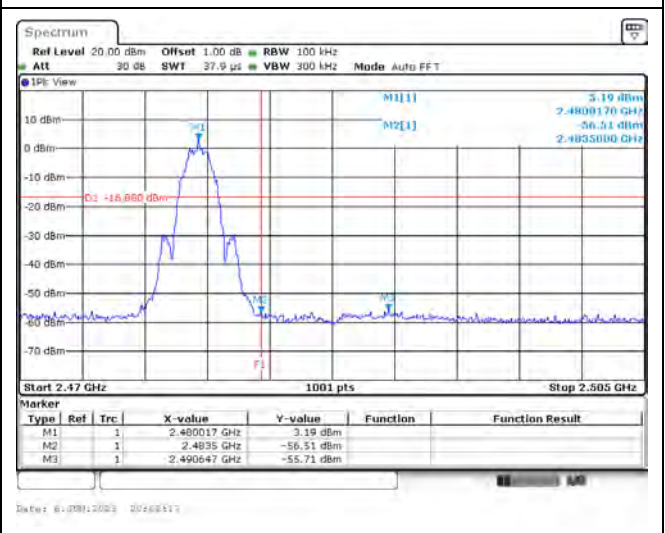

Appendix F. Test Result of Transmitter Radiated Spurious Emission

30 MHz ~ 1 GHz

Mode 1: EUT + Adapter

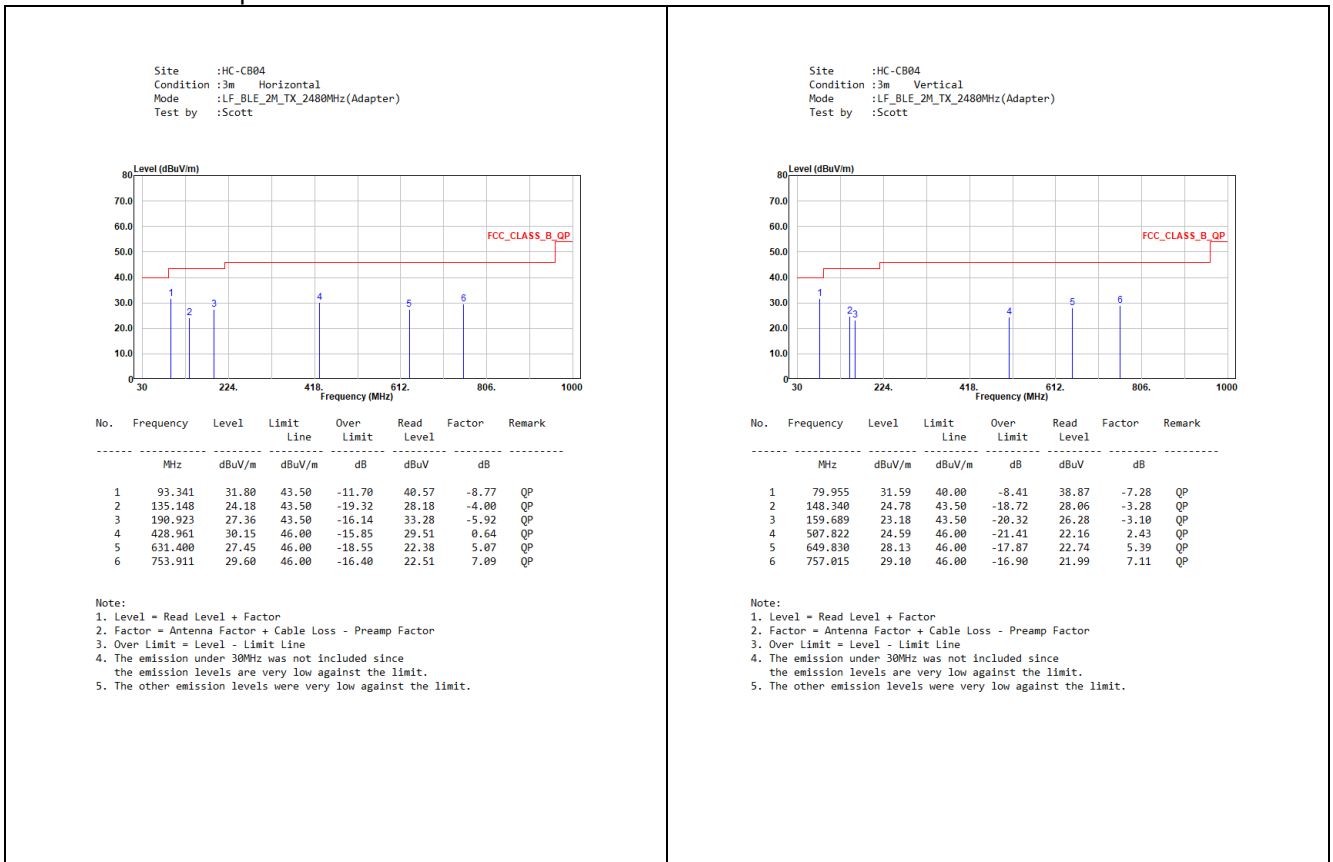

Mode 2: EUT + PoE

Site :HC-CB04
 Condition :3m Horizontal
 Mode :LF_BLE_2M_TX_2480MHz(POE)
 Test by :Scott

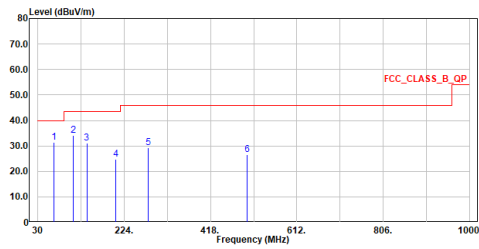

No.	Frequency MHz	Level dBuV/m	Limit Line dBuV/m	Over Limit dB	Read Level dBuV	Factor dB	Remark
1	66.569	31.26	40.00	-8.74	35.58	-4.32	QP
2	109.928	34.00	43.50	-9.50	40.23	-6.23	QP
3	139.998	31.01	43.50	-12.49	34.98	-3.97	QP
4	205.570	24.77	43.50	-18.73	31.59	-6.82	QP
5	278.126	29.25	46.00	-16.75	32.52	-3.27	QP
6	499.965	26.43	46.00	-19.57	24.42	2.01	QP

Note:

1. Level = Read Level + Factor
2. Factor = Antenna Factor + Cable Loss - Preamp Factor
3. Over Limit = Level - Limit Line
4. The emission under 30MHz was not included since the emission levels are very low against the limit.
5. The other emission levels were very low against the limit.

Site :HC-CB04
 Condition :3m Vertical
 Mode :LF_BLE_2M_TX_2480MHz(POE)
 Test by :Scott

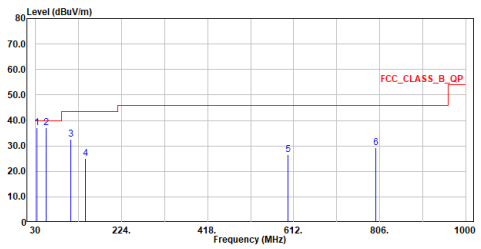

No.	Frequency MHz	Level dBuV/m	Limit Line dBuV/m	Over Limit dB	Read Level dBuV	Factor dB	Remark
1	33.880	37.25	40.00	-2.75	40.30	-3.05	QP
2	53.959	37.08	40.00	-2.92	40.10	-3.02	QP
3	109.928	32.52	43.50	-10.98	38.75	-6.23	QP
4	141.938	25.07	43.50	-18.43	28.85	-3.78	QP
5	599.196	26.48	46.00	-19.52	21.99	4.49	QP
6	797.658	29.43	46.00	-16.57	22.27	7.16	QP

Note:

1. Level = Read Level + Factor
2. Factor = Antenna Factor + Cable Loss - Preamp Factor
3. Over Limit = Level - Limit Line
4. The emission under 30MHz was not included since the emission levels are very low against the limit.
5. The other emission levels were very low against the limit.

Above 1 GHz

Site :HC-CB04
 Condition :3m ,Horizontal
 Mode :BLE_1M_TX_2402MHz
 Test by :Gary

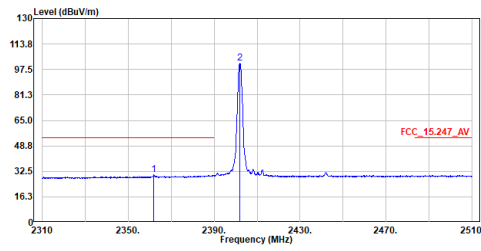

No.	Frequency MHz	Level dBuV/m	Limit Line dBuV/m	Over Limit dB	Read Level dBuV	Factor dB	Remark
1	2362.000	30.20	54.00	-23.80	18.29	11.91	Average
2	2402.000	101.48	-----	-----	89.39	12.09	Average

Note:
 1. Level = Read Level + Factor
 2. Factor = Antenna Factor + Cable Loss - Preamp Factor
 3. Over Limit = Level - Limit Line
 4. The peak result complies with AVG limit, AVG result is deemed to comply with AVG limit.
 5. The other emission levels were very low against the limit.

Site :HC-CB04
 Condition :3m ,Horizontal
 Mode :BLE_1M_TX_2402MHz
 Test by :Gary

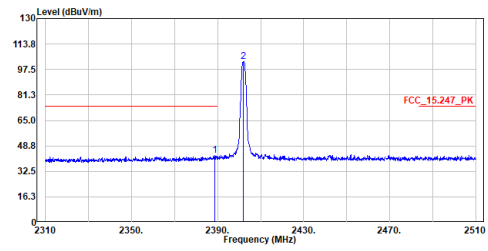

No.	Frequency MHz	Level dBuV/m	Limit Line dBuV/m	Over Limit dB	Read Level dBuV	Factor dB	Remark
1	2388.700	42.87	74.00	-31.13	30.84	12.03	Peak
2	2402.100	102.45	-----	-----	90.36	12.09	Peak

Note:
 1. Level = Read Level + Factor
 2. Factor = Antenna Factor + Cable Loss - Preamp Factor
 3. Over Limit = Level - Limit Line
 4. The peak result complies with AVG limit, AVG result is deemed to comply with AVG limit.
 5. The other emission levels were very low against the limit.

Site :HC-CB04
 Condition :3m ,Vertical
 Mode :BLE_1M_TX_2402MHz
 Test by :Gary

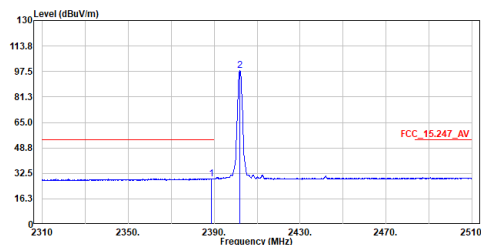

No.	Frequency MHz	Level dBuV/m	Limit Line dBuV/m	Over Limit dB	Read Level dBuV	Factor dB	Remark
1	2388.600	29.18	54.00	-24.82	17.15	12.03	Average
2	2402.000	98.20	-----	-----	86.11	12.09	Average

Note:
 1. Level = Read Level + Factor
 2. Factor = Antenna Factor + Cable Loss - Preamp Factor
 3. Over Limit = Level - Limit Line
 4. The peak result complies with AVG limit, AVG result is deemed to comply with AVG limit.
 5. The other emission levels were very low against the limit.

Site :HC-CB04
 Condition :3m ,Vertical
 Mode :BLE_1M_TX_2402MHz
 Test by :Gary

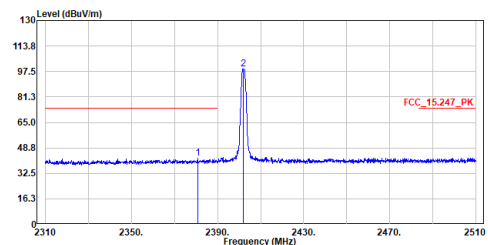

No.	Frequency MHz	Level dBuV/m	Limit Line dBuV/m	Over Limit dB	Read Level dBuV	Factor dB	Remark
1	2380.900	42.05	74.00	-31.95	30.05	12.00	Peak
2	2402.100	99.21	-----	-----	87.12	12.09	Peak

Note:
 1. Level = Read Level + Factor
 2. Factor = Antenna Factor + Cable Loss - Preamp Factor
 3. Over Limit = Level - Limit Line
 4. The peak result complies with AVG limit, AVG result is deemed to comply with AVG limit.
 5. The other emission levels were very low against the limit.

Site :HC-CB04
 Condition :3m ,Horizontal
 Mode :BLE_1M_TX_2402MHz
 Test by :Gary

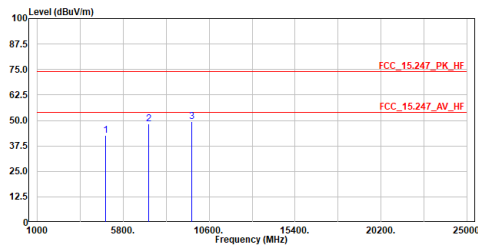

No.	Frequency MHz	Level dBuV/m	Limit Line dBuV/m	Over Limit dB	Read Level dBuV	Factor dB	Remark
1	4804.000	42.76	74.00	-31.24	58.69	-15.93	Peak
2	7206.000	48.30	74.00	-25.70	58.78	-10.48	Peak
3	9608.000	49.39	74.00	-24.61	55.86	-6.47	Peak

Note:
 1. Level = Read Level + Factor
 2. Factor = Antenna Factor + Cable Loss - Preamp Factor
 3. Over Limit = Level - Limit Line
 4. The peak result complies with AVG limit, AVG result is deemed to comply with AVG limit.
 5. The other emission levels were very low against the limit.

Site :HC-CB04
 Condition :3m ,Vertical
 Mode :BLE_1M_TX_2402MHz
 Test by :Gary

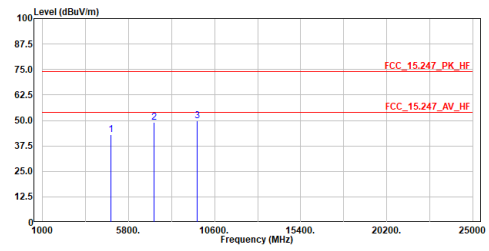

No.	Frequency MHz	Level dBuV/m	Limit Line dBuV/m	Over Limit dB	Read Level dBuV	Factor dB	Remark
1	4804.000	42.83	74.00	-31.17	58.76	-15.93	Peak
2	7206.000	48.97	74.00	-25.03	59.45	-10.48	Peak
3	9608.000	49.98	74.00	-24.02	56.45	-6.47	Peak

Note:
 1. Level = Read Level + Factor
 2. Factor = Antenna Factor + Cable Loss - Preamp Factor
 3. Over Limit = Level - Limit Line
 4. The peak result complies with AVG limit, AVG result is deemed to comply with AVG limit.
 5. The other emission levels were very low against the limit.

Site :HC-CB04
 Condition :3m ,Horizontal
 Mode :BLE_1M_TX_2440MHz
 Test by :Gary

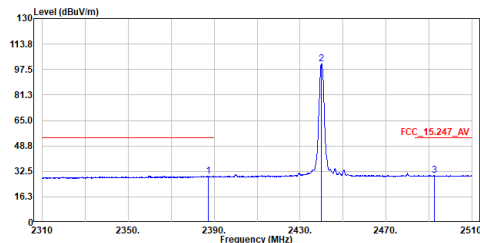

No.	Frequency MHz	Level dBuV/m	Limit Line dBuV/m	Over Limit dB	Read Level dBuV	Factor dB	Remark
1	2387.200	29.42	54.00	-24.58	17.39	12.03	Average
2	2440.000	101.27	-----	-----	89.00	12.27	Average
3	2492.400	29.84	54.00	-24.16	17.32	12.52	Average

Note:
 1. Level = Read Level + Factor
 2. Factor = Antenna Factor + Cable Loss - Preamp Factor
 3. Over Limit = Level - Limit Line
 4. The peak result complies with AVG limit, AVG result is deemed to comply with AVG limit.
 5. The other emission levels were very low against the limit.

Site :HC-CB04
 Condition :3m ,Horizontal
 Mode :BLE_1M_TX_2440MHz
 Test by :Gary

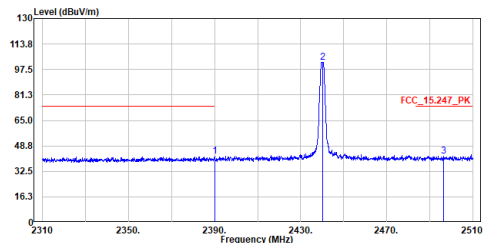

No.	Frequency MHz	Level dBuV/m	Limit Line dBuV/m	Over Limit dB	Read Level dBuV	Factor dB	Remark
1	2390.000	42.00	74.00	-32.00	29.97	12.03	Peak
2	2440.100	102.24	-----	-----	89.97	12.27	Peak
3	2496.300	42.32	74.00	-31.68	29.79	12.53	Peak

Note:
 1. Level = Read Level + Factor
 2. Factor = Antenna Factor + Cable Loss - Preamp Factor
 3. Over Limit = Level - Limit Line
 4. The peak result complies with AVG limit, AVG result is deemed to comply with AVG limit.
 5. The other emission levels were very low against the limit.

Site :HC-CB04
 Condition :3m ,Vertical
 Mode :BLE_1M_TX_2440MHz
 Test by :Gary

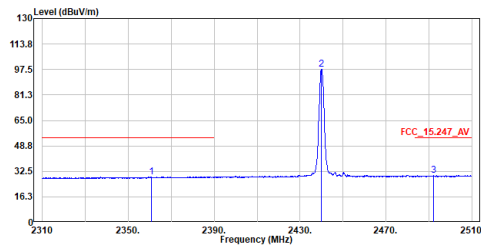

No.	Frequency MHz	Level dBuV/m	Limit Line dBuV/m	Over Limit dB	Read Level dBuV	Factor dB	Remark
1	2360.700	29.02	54.00	-24.98	17.11	11.91	Average
2	2440.000	97.58	-----	-----	85.31	12.27	Average
3	2492.100	29.77	54.00	-24.23	17.25	12.52	Average

Note:
 1. Level = Read Level + Factor
 2. Factor = Antenna Factor + Cable Loss - Preamp Factor
 3. Over Limit = Level - Limit Line
 4. The peak result complies with AVG limit, AVG result is deemed to comply with AVG limit.
 5. The other emission levels were very low against the limit.

Site :HC-CB04
 Condition :3m ,Vertical
 Mode :BLE_1M_TX_2440MHz
 Test by :Gary

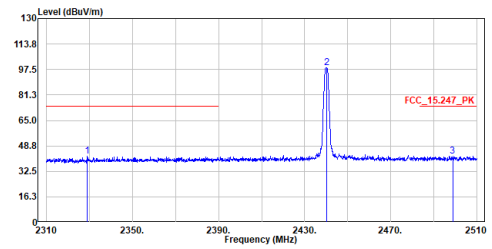

No.	Frequency MHz	Level dBuV/m	Limit Line dBuV/m	Over Limit dB	Read Level dBuV	Factor dB	Remark
1	2329.000	42.06	74.00	-31.94	30.30	11.76	Peak
2	2440.100	98.53	-----	-----	86.26	12.27	Peak
3	2498.000	42.33	74.00	-31.67	29.78	12.55	Peak

Note:
 1. Level = Read Level + Factor
 2. Factor = Antenna Factor + Cable Loss - Preamp Factor
 3. Over Limit = Level - Limit Line
 4. The peak result complies with AVG limit, AVG result is deemed to comply with AVG limit.
 5. The other emission levels were very low against the limit.

Site :HC-CB04
 Condition :3m ,Horizontal
 Mode :BLE_1M_TX_2440MHz
 Test by :Gary

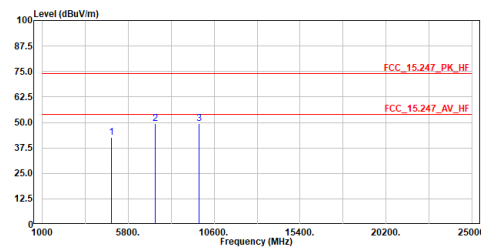

No.	Frequency MHz	Level dBuV/m	Limit Line dBuV/m	Over Limit dB	Read Level dBuV	Factor dB	Remark
1	4880.000	42.77	74.00	-31.23	58.43	-15.66	Peak
2	7320.000	49.59	74.00	-24.41	59.84	-10.25	Peak
3	9760.000	49.46	74.00	-24.54	55.71	-6.25	Peak

Note:
 1. Level = Read Level + Factor
 2. Factor = Antenna Factor + Cable Loss - Preamp Factor
 3. Over Limit = Level - Limit Line
 4. The peak result complies with AVG limit, AVG result is deemed to comply with AVG limit.
 5. The other emission levels were very low against the limit.

Site :HC-CB04
 Condition :3m ,Vertical
 Mode :BLE_1M_TX_2440MHz
 Test by :Gary

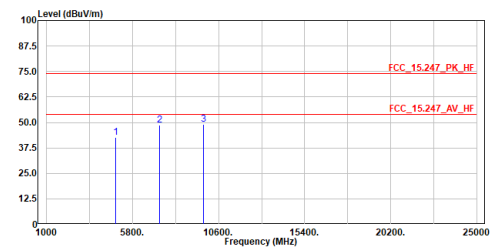

No.	Frequency MHz	Level dBuV/m	Limit Line dBuV/m	Over Limit dB	Read Level dBuV	Factor dB	Remark
1	4880.000	42.60	74.00	-31.40	58.26	-15.66	Peak
2	7320.000	48.67	74.00	-25.33	58.92	-10.25	Peak
3	9760.000	49.15	74.00	-24.85	55.40	-6.25	Peak

Note:
 1. Level = Read Level + Factor
 2. Factor = Antenna Factor + Cable Loss - Preamp Factor
 3. Over Limit = Level - Limit Line
 4. The peak result complies with AVG limit, AVG result is deemed to comply with AVG limit.
 5. The other emission levels were very low against the limit.

Site :HC-CB04
 Condition :3m ,Horizontal
 Mode :BLE_1M_TX_2480MHz
 Test by :Gary

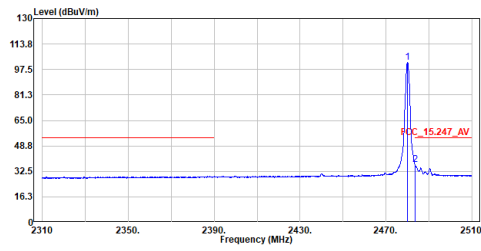

No.	Frequency MHz	Level dBuV/m	Limit Line dBuV/m	Over Limit dB	Read Level dBuV	Factor dB	Remark
1	2480.100	101.84	-----	-----	89.38	12.46	Average
2	2483.600	36.74	54.00	-17.26	24.27	12.47	Average

Note:
 1. Level = Read Level + Factor
 2. Factor = Antenna Factor + Cable Loss - Preamp Factor
 3. Over Limit = Level - Limit Line
 4. The peak result complies with AVG limit, AVG result is deemed to comply with AVG limit.
 5. The other emission levels were very low against the limit.

Site :HC-CB04
 Condition :3m ,Horizontal
 Mode :BLE_1M_TX_2480MHz
 Test by :Gary

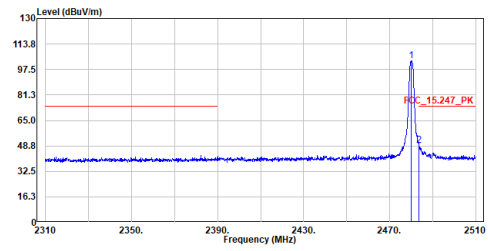

No.	Frequency MHz	Level dBuV/m	Limit Line dBuV/m	Over Limit dB	Read Level dBuV	Factor dB	Remark
1	2480.100	102.85	-----	-----	90.39	12.46	Peak
2	2483.600	49.11	74.00	-24.89	36.64	12.47	Peak

Note:
 1. Level = Read Level + Factor
 2. Factor = Antenna Factor + Cable Loss - Preamp Factor
 3. Over Limit = Level - Limit Line
 4. The peak result complies with AVG limit, AVG result is deemed to comply with AVG limit.
 5. The other emission levels were very low against the limit.

Site :HC-CB04
 Condition :3m ,Vertical
 Mode :BLE_1M_TX_2480MHz
 Test by :Gary

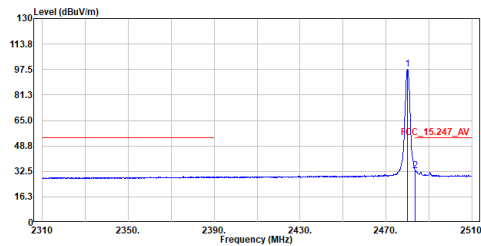

No.	Frequency MHz	Level dBuV/m	Limit Line dBuV/m	Over Limit dB	Read Level dBuV	Factor dB	Remark
1	2480.000	97.54	-----	-----	85.08	12.46	Average
2	2483.600	33.10	54.00	-20.90	20.63	12.47	Average

Note:
 1. Level = Read Level + Factor
 2. Factor = Antenna Factor + Cable Loss - Preamp Factor
 3. Over Limit = Level - Limit Line
 4. The peak result complies with AVG limit, AVG result is deemed to comply with AVG limit.
 5. The other emission levels were very low against the limit.

Site :HC-CB04
 Condition :3m ,Vertical
 Mode :BLE_1M_TX_2480MHz
 Test by :Gary

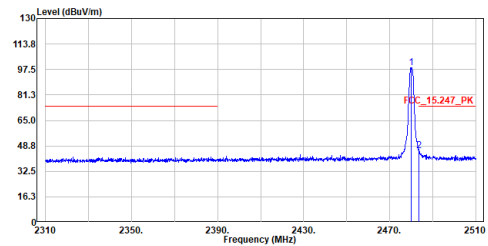

No.	Frequency MHz	Level dBuV/m	Limit Line dBuV/m	Over Limit dB	Read Level dBuV	Factor dB	Remark
1	2480.100	98.56	-----	-----	86.10	12.46	Peak
2	2483.700	45.47	74.00	-28.53	33.00	12.47	Peak

Note:
 1. Level = Read Level + Factor
 2. Factor = Antenna Factor + Cable Loss - Preamp Factor
 3. Over Limit = Level - Limit Line
 4. The peak result complies with AVG limit, AVG result is deemed to comply with AVG limit.
 5. The other emission levels were very low against the limit.

Site :HC-CB04
 Condition :3m ,Horizontal
 Mode :BLE_1M_TX_2480MHz
 Test by :Gary

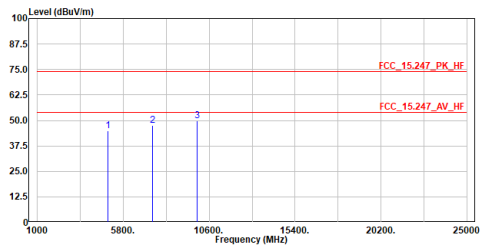

No.	Frequency MHz	Level dBuV/m	Limit Line dBuV/m	Over Limit dB	Read Level dBuV	Factor dB	Remark
1	4960.000	44.72	74.00	-29.28	60.09	-15.37	Peak
2	7440.000	47.69	74.00	-26.31	57.72	-10.03	Peak
3	9920.000	49.87	74.00	-24.13	55.89	-6.02	Peak

Note:
 1. Level = Read Level + Factor
 2. Factor = Antenna Factor + Cable Loss - Preamp Factor
 3. Over Limit = Level - Limit Line
 4. The peak result complies with AVG limit, AVG result is deemed to comply with AVG limit.
 5. The other emission levels were very low against the limit.

Site :HC-CB04
 Condition :3m ,Vertical
 Mode :BLE_1M_TX_2480MHz
 Test by :Gary

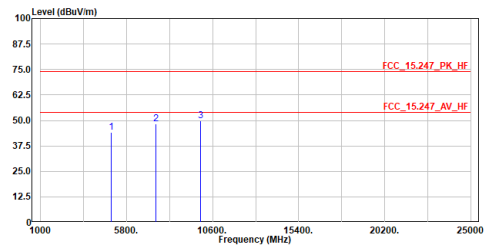

No.	Frequency MHz	Level dBuV/m	Limit Line dBuV/m	Over Limit dB	Read Level dBuV	Factor dB	Remark
1	4960.000	44.05	74.00	-29.95	59.42	-15.37	Peak
2	7440.000	48.27	74.00	-25.73	58.30	-10.03	Peak
3	9920.000	49.63	74.00	-24.37	55.65	-6.02	Peak

Note:
 1. Level = Read Level + Factor
 2. Factor = Antenna Factor + Cable Loss - Preamp Factor
 3. Over Limit = Level - Limit Line
 4. The peak result complies with AVG limit, AVG result is deemed to comply with AVG limit.
 5. The other emission levels were very low against the limit.

Site :HC-CB04
 Condition :3m ,Horizontal
 Mode :BLE_2M_TX_2402MHz
 Test by :Gary

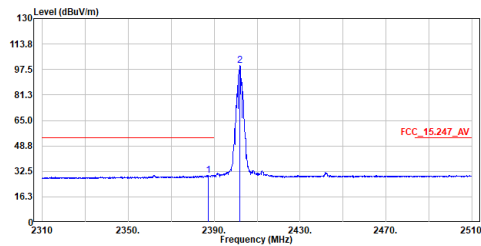

No.	Frequency MHz	Level dBuV/m	Limit Line dBuV/m	Over Limit dB	Read Level dBuV	Factor dB	Remark
1	2387.400	30.08	54.00	-23.92	18.05	12.03	Average
2	2402.100	99.87	-----	-----	87.78	12.09	Average

Note:
 1. Level = Read Level + Factor
 2. Factor = Antenna Factor + Cable Loss - Preamp Factor
 3. Over Limit = Level - Limit Line
 4. The peak result complies with AVG limit, AVG result is deemed to comply with AVG limit.
 5. The other emission levels were very low against the limit.

Site :HC-CB04
 Condition :3m ,Horizontal
 Mode :BLE_2M_TX_2402MHz
 Test by :Gary

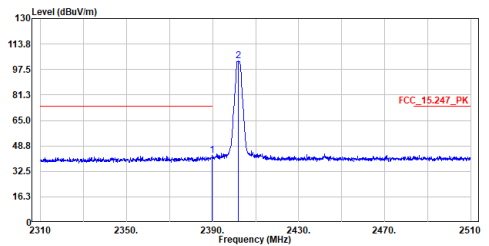

No.	Frequency MHz	Level dBuV/m	Limit Line dBuV/m	Over Limit dB	Read Level dBuV	Factor dB	Remark
1	2389.800	42.52	74.00	-31.48	30.49	12.03	Peak
2	2402.100	102.90	-----	-----	90.81	12.09	Peak

Note:
 1. Level = Read Level + Factor
 2. Factor = Antenna Factor + Cable Loss - Preamp Factor
 3. Over Limit = Level - Limit Line
 4. The peak result complies with AVG limit, AVG result is deemed to comply with AVG limit.
 5. The other emission levels were very low against the limit.

Site :HC-CB04
 Condition :3m ,Vertical
 Mode :BLE_2M_TX_2402MHz
 Test by :Gary

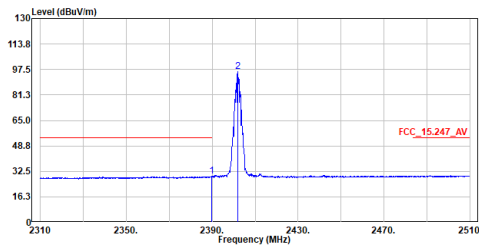

No.	Frequency MHz	Level dBuV/m	Limit dBuV/m	Over Limit dB	Read Level dBuV	Factor dB	Remark
1	2389.700	29.20	54.00	-24.80	17.17	12.03	Average
2	2402.000	96.13	-----	-----	84.04	12.09	Average

Note:
 1. Level = Read Level + Factor
 2. Factor = Antenna Factor + Cable Loss - Preamp Factor
 3. Over Limit = Level - Limit Line
 4. The peak result complies with AVG limit, AVG result is deemed to comply with AVG limit.
 5. The other emission levels were very low against the limit.

Site :HC-CB04
 Condition :3m ,Vertical
 Mode :BLE_2M_TX_2402MHz
 Test by :Gary

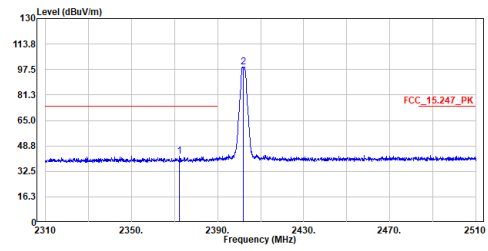

No.	Frequency MHz	Level dBuV/m	Limit dBuV/m	Over Limit dB	Read Level dBuV	Factor dB	Remark
1	2372.400	42.26	74.00	-31.74	30.30	11.96	Peak
2	2402.100	99.04	-----	-----	86.95	12.09	Peak

Note:
 1. Level = Read Level + Factor
 2. Factor = Antenna Factor + Cable Loss - Preamp Factor
 3. Over Limit = Level - Limit Line
 4. The peak result complies with AVG limit, AVG result is deemed to comply with AVG limit.
 5. The other emission levels were very low against the limit.

Site :HC-CB04
 Condition :3m ,Horizontal
 Mode :BLE_2M_TX_2402MHz
 Test by :Gary

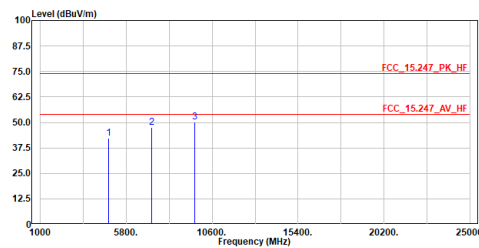

No.	Frequency MHz	Level dBuV/m	Limit dBuV/m	Over Limit dB	Read Level dBuV	Factor dB	Remark
1	4804.000	42.08	74.00	-31.92	58.01	-15.93	Peak
2	7206.000	47.69	74.00	-26.31	58.17	-10.48	Peak
3	9608.000	50.11	74.00	-23.89	56.58	-6.47	Peak

Note:
 1. Level = Read Level + Factor
 2. Factor = Antenna Factor + Cable Loss - Preamp Factor
 3. Over Limit = Level - Limit Line
 4. The peak result complies with AVG limit, AVG result is deemed to comply with AVG limit.
 5. The other emission levels were very low against the limit.

Site :HC-CB04
 Condition :3m ,Vertical
 Mode :BLE_2M_TX_2402MHz
 Test by :Gary

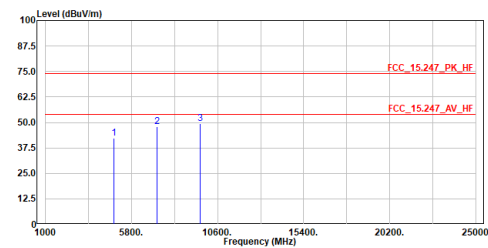

No.	Frequency MHz	Level dBuV/m	Limit dBuV/m	Over Limit dB	Read Level dBuV	Factor dB	Remark
1	4804.000	42.39	74.00	-31.61	58.32	-15.93	Peak
2	7206.000	47.89	74.00	-26.11	58.37	-10.48	Peak
3	9608.000	49.39	74.00	-24.61	55.86	-6.47	Peak

Note:
 1. Level = Read Level + Factor
 2. Factor = Antenna Factor + Cable Loss - Preamp Factor
 3. Over Limit = Level - Limit Line
 4. The peak result complies with AVG limit, AVG result is deemed to comply with AVG limit.
 5. The other emission levels were very low against the limit.

Site :HC-CB04
 Condition :3m ,Horizontal
 Mode :BLE_2M_TX_2440MHz
 Test by :Gary

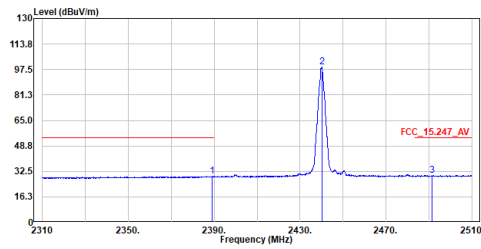

No.	Frequency MHz	Level dBuV/m	Limit Line dBuV/m	Over Limit dB	Read Level dBuV	Factor dB	Remark
1	2388.900	29.30	54.00	-24.70	17.27	12.03	Average
2	2440.100	99.06	-----	-----	86.79	12.27	Average
3	2491.500	29.99	54.00	-24.01	17.48	12.51	Average

Note:
 1. Level = Read Level + Factor
 2. Factor = Antenna Factor + Cable Loss - Preamp Factor
 3. Over Limit = Level - Limit Line
 4. The peak result complies with AVG limit, AVG result is deemed to comply with AVG limit.
 5. The other emission levels were very low against the limit.

Site :HC-CB04
 Condition :3m ,Horizontal
 Mode :BLE_2M_TX_2440MHz
 Test by :Gary

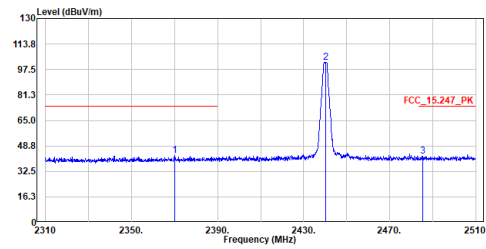

No.	Frequency MHz	Level dBuV/m	Limit Line dBuV/m	Over Limit dB	Read Level dBuV	Factor dB	Remark
1	2370.000	42.63	74.00	-31.37	30.68	11.95	Peak
2	2440.100	102.28	-----	-----	90.01	12.27	Peak
3	2485.300	42.13	74.00	-31.87	29.65	12.48	Peak

Note:
 1. Level = Read Level + Factor
 2. Factor = Antenna Factor + Cable Loss - Preamp Factor
 3. Over Limit = Level - Limit Line
 4. The peak result complies with AVG limit, AVG result is deemed to comply with AVG limit.
 5. The other emission levels were very low against the limit.

Site :HC-CB04
 Condition :3m ,Vertical
 Mode :BLE_2M_TX_2440MHz
 Test by :Gary

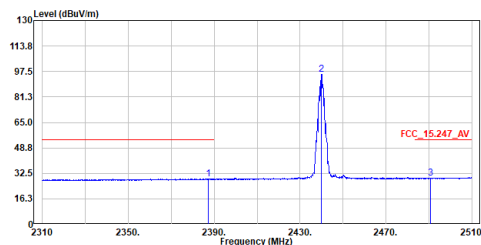

No.	Frequency MHz	Level dBuV/m	Limit Line dBuV/m	Over Limit dB	Read Level dBuV	Factor dB	Remark
1	2387.300	29.08	54.00	-24.92	17.05	12.03	Average
2	2440.000	95.60	-----	-----	83.33	12.27	Average
3	2490.800	29.66	54.00	-24.34	17.15	12.51	Average

Note:
 1. Level = Read Level + Factor
 2. Factor = Antenna Factor + Cable Loss - Preamp Factor
 3. Over Limit = Level - Limit Line
 4. The peak result complies with AVG limit, AVG result is deemed to comply with AVG limit.
 5. The other emission levels were very low against the limit.

Site :HC-CB04
 Condition :3m ,Vertical
 Mode :BLE_2M_TX_2440MHz
 Test by :Gary

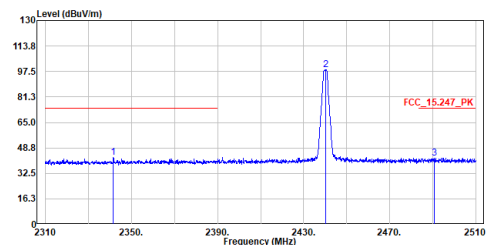

No.	Frequency MHz	Level dBuV/m	Limit Line dBuV/m	Over Limit dB	Read Level dBuV	Factor dB	Remark
1	2341.600	42.54	74.00	-31.46	30.73	11.81	Peak
2	2440.100	98.51	-----	-----	86.24	12.27	Peak
3	2490.700	42.31	74.00	-31.69	29.80	12.51	Peak

Note:
 1. Level = Read Level + Factor
 2. Factor = Antenna Factor + Cable Loss - Preamp Factor
 3. Over Limit = Level - Limit Line
 4. The peak result complies with AVG limit, AVG result is deemed to comply with AVG limit.
 5. The other emission levels were very low against the limit.

Site :HC-CB04
 Condition :3m ,Horizontal
 Mode :BLE_2M_TX_2440MHz
 Test by :Gary

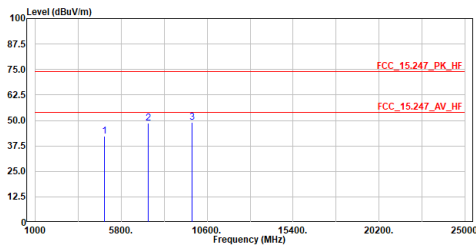

No.	Frequency MHz	Level dBuV/m	Limit Line dBuV/m	Over Limit dB	Read Level dBuV	Factor dB	Remark
1	4880.000	42.18	74.00	-31.82	57.84	-15.66	Peak
2	7320.000	48.56	74.00	-25.44	58.81	-10.25	Peak
3	9760.000	49.18	74.00	-24.82	55.43	-6.25	Peak

Note:
 1. Level = Read Level + Factor
 2. Factor = Antenna Factor + Cable Loss - Preamp Factor
 3. Over Limit = Level - Limit Line
 4. The peak result complies with AVG limit, AVG result is deemed to comply with AVG limit.
 5. The other emission levels were very low against the limit.

Site :HC-CB04
 Condition :3m ,Vertical
 Mode :BLE_2M_TX_2440MHz
 Test by :Gary

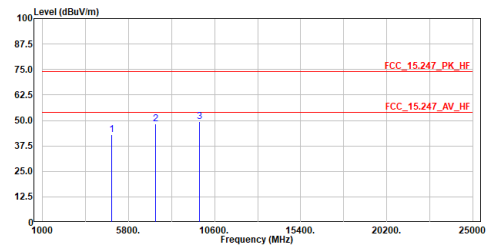

No.	Frequency MHz	Level dBuV/m	Limit Line dBuV/m	Over Limit dB	Read Level dBuV	Factor dB	Remark
1	4880.000	42.86	74.00	-31.14	58.52	-15.66	Peak
2	7320.000	48.30	74.00	-25.70	58.55	-10.25	Peak
3	9760.000	49.35	74.00	-24.65	55.60	-6.25	Peak

Note:
 1. Level = Read Level + Factor
 2. Factor = Antenna Factor + Cable Loss - Preamp Factor
 3. Over Limit = Level - Limit Line
 4. The peak result complies with AVG limit, AVG result is deemed to comply with AVG limit.
 5. The other emission levels were very low against the limit.

Site :HC-CB04
 Condition :3m ,Horizontal
 Mode :BLE_2M_TX_2480MHz
 Test by :Gary

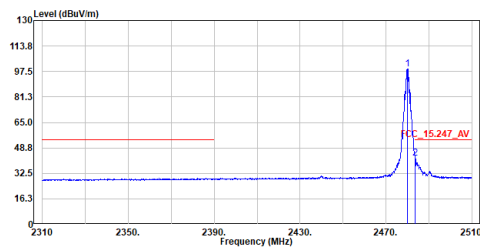

No.	Frequency MHz	Level dBuV/m	Limit Line dBuV/m	Over Limit dB	Read Level dBuV	Factor dB	Remark
1	2480.100	99.25	-----	-----	86.79	12.46	Average
2	2483.600	42.29	54.00	-11.71	29.82	12.47	Average

Note:
 1. Level = Read Level + Factor
 2. Factor = Antenna Factor + Cable Loss - Preamp Factor
 3. Over Limit = Level - Limit Line
 4. The peak result complies with AVG limit, AVG result is deemed to comply with AVG limit.
 5. The other emission levels were very low against the limit.

Site :HC-CB04
 Condition :3m ,Horizontal
 Mode :BLE_2M_TX_2480MHz
 Test by :Gary

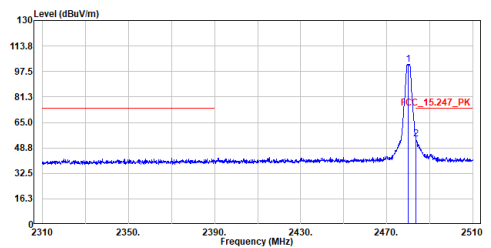

No.	Frequency MHz	Level dBuV/m	Limit Line dBuV/m	Over Limit dB	Read Level dBuV	Factor dB	Remark
1	2480.100	102.23	-----	-----	89.77	12.46	Peak
2	2483.700	54.27	74.00	-19.73	41.80	12.47	Peak

Note:
 1. Level = Read Level + Factor
 2. Factor = Antenna Factor + Cable Loss - Preamp Factor
 3. Over Limit = Level - Limit Line
 4. The peak result complies with AVG limit, AVG result is deemed to comply with AVG limit.
 5. The other emission levels were very low against the limit.

Site :HC-CB04
 Condition :3m ,Vertical
 Mode :BLE_2M_TX_2480MHz
 Test by :Gary

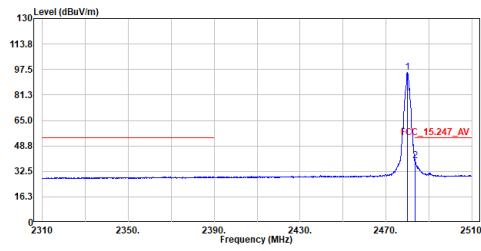

No.	Frequency MHz	Level dBuV/m	Limit Line dBuV/m	Over Limit dB	Read Level dBuV	Factor dB	Remark
1	2479.900	95.44	-----	-----	82.98	12.46	Average
2	2483.600	39.48	54.00	-14.52	27.01	12.47	Average

Note:
 1. Level = Read Level + Factor
 2. Factor = Antenna Factor + Cable Loss - Preamp Factor
 3. Over Limit = Level - Limit Line
 4. The peak result complies with AVG limit, AVG result is deemed to comply with AVG limit.
 5. The other emission levels were very low against the limit.

Site :HC-CB04
 Condition :3m ,Vertical
 Mode :BLE_2M_TX_2480MHz
 Test by :Gary

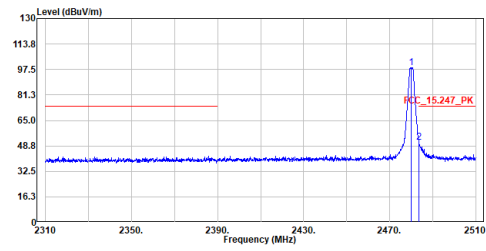

No.	Frequency MHz	Level dBuV/m	Limit Line dBuV/m	Over Limit dB	Read Level dBuV	Factor dB	Remark
1	2480.100	98.68	-----	-----	86.22	12.46	Peak
2	2483.600	51.02	74.00	-22.98	38.55	12.47	Peak

Note:
 1. Level = Read Level + Factor
 2. Factor = Antenna Factor + Cable Loss - Preamp Factor
 3. Over Limit = Level - Limit Line
 4. The peak result complies with AVG limit, AVG result is deemed to comply with AVG limit.
 5. The other emission levels were very low against the limit.

Site :HC-CB04
 Condition :3m ,Horizontal
 Mode :BLE_2M_TX_2480MHz
 Test by :Gary

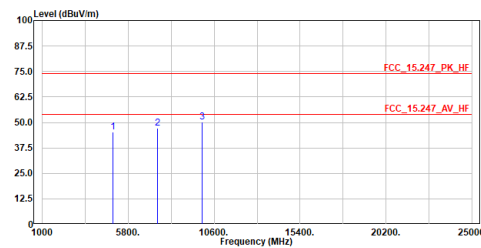

No.	Frequency MHz	Level dBuV/m	Limit Line dBuV/m	Over Limit dB	Read Level dBuV	Factor dB	Remark
1	4960.000	45.29	74.00	-28.71	60.66	-15.37	Peak
2	7440.000	47.32	74.00	-26.68	57.35	-10.03	Peak
3	9920.000	50.00	74.00	-24.00	56.02	-6.02	Peak

Note:
 1. Level = Read Level + Factor
 2. Factor = Antenna Factor + Cable Loss - Preamp Factor
 3. Over Limit = Level - Limit Line
 4. The peak result complies with AVG limit, AVG result is deemed to comply with AVG limit.
 5. The other emission levels were very low against the limit.

Site :HC-CB04
 Condition :3m ,Vertical
 Mode :BLE_2M_TX_2480MHz
 Test by :Gary

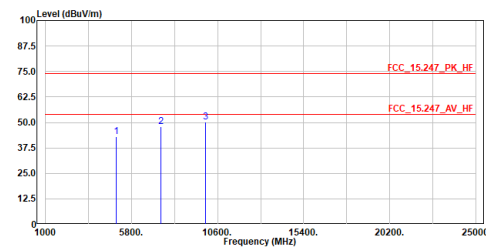

No.	Frequency MHz	Level dBuV/m	Limit Line dBuV/m	Over Limit dB	Read Level dBuV	Factor dB	Remark
1	4960.000	43.14	74.00	-30.86	58.51	-15.37	Peak
2	7440.000	47.97	74.00	-26.03	58.00	-10.03	Peak
3	9920.000	50.27	74.00	-23.73	56.29	-6.02	Peak

Note:
 1. Level = Read Level + Factor
 2. Factor = Antenna Factor + Cable Loss - Preamp Factor
 3. Over Limit = Level - Limit Line
 4. The peak result complies with AVG limit, AVG result is deemed to comply with AVG limit.
 5. The other emission levels were very low against the limit.