



Test Report No:  
2410358R-RFUSV18S-A

## TEST REPORT (Dynamic Frequency Selection) FCC Rules&Regulations

Product Name	VX5 HD Indoor Camera
Brand Name	resideo
Model No.	CAMW-WI
FCC ID	CFS8DLCAMWEWI1
Applicant's Name / Address	Ademco Inc. 2 Corporate Center Drive, Suite 100, Melville, New York 11747, United States
Manufacturer's Name	XAVi Technologies Corporation
Test Method Requested, Standard	FCC CFR Title 47 Part 15 Subpart E Section 15.407 KDB 905462
Verdict Summary	IN COMPLIANCE
Documented By Jinn Chen	<i>Jinn Chen</i>
Tested By Benjamin Pan	<i>Benjamin Pan</i>
Approved By Steven Tsai	<i>Steven Tsai</i>
Date of Receipt	2024/01/12
Date of Issue	2024/07/19
Report Version	V1.0

## INDEX

	<b>page</b>
Competences and Guarantees.....	3
General Conditions.....	3
Revision History.....	4
Summary of Test Result.....	5
1. General Information.....	6
1.1. EUT Description.....	6
1.2. EUT Information.....	6
1.3. Testing Location Information.....	7
1.4. Measurement Uncertainty.....	8
1.5. List of Test Equipment.....	8
2. Test Configuration of EUT.....	9
2.1. Test Condition.....	9
2.2. Test Channel Frequencies Configuration.....	9
2.3. Measurement Configuration.....	9
2.4. Tested System Details.....	9
2.5. Standard Requirement.....	10
2.6. UNII Device Description.....	10
3. General DFS Information.....	11
3.1. Test Setup.....	11
3.2. DFS Detection Thresholds.....	11
4. Radar Test Waveforms.....	13
4.1. Radar Waveform Calibration.....	16
4.2. Test Result of Radar Waveform Calibration.....	17
4.3. Test Result of Master Data Traffic Plot.....	18
5. In-Service Monitoring for Channel Move Time, Channel Closing Transmission Time and Non-Occupancy Period.....	19
5.1. Test Procedure.....	19
5.2. Test Requirement.....	19
5.3. Test Result of Channel Move Time and Channel Closing Transmission Time.....	20
5.4. Test Result of Non-Occupancy Period.....	21
Appendix A. Test Result of Radar Waveform Calibration	
Appendix B. Test Result of Master Data Traffic Plot	
Appendix C. Test Result of Channel Move Time and Channel Closing Transmission Time	
Appendix D. Test Result of Non-Occupancy Period	
Appendix E. Test Setup Photograph	

---

## Competences and Guarantees

---

DEKRA is a testing laboratory competent to carry out the tests described in this report.

In order to assure the traceability to other national and international laboratories, DEKRA has a calibration and maintenance program for its measurement equipment.

DEKRA guarantees the reliability of the data presented in this report, which is the result of the measurements and the tests performed to the item under test on the date and under the conditions stated in the report and it is based on the knowledge and technical facilities available at DEKRA at the time of performance of the test.

DEKRA is liable to the client for the maintenance of the confidentiality of all information related to the item under test and the results of the test.

The results presented in this Test Report apply only to the particular item under test established in this document.

**IMPORTANT:** No parts of this report may be reproduced or quoted out of context, in any form or by any means, except in full, without the previous written permission of DEKRA.

---

## General Conditions

---

1. The test results relate only to the samples tested.
2. The test results shown in the test report are traceable to the national/international standard through the calibration report of the equipment and evaluated measurement uncertainty herein.
3. This report must not be used to claim product endorsement by TAF or any agency of the government.
4. The test report shall not be reproduced without the written approval of DEKRA Testing and Certification Co., Ltd.
5. Measurement uncertainties evaluated for each testing system and associated connections are given here to provide the system information for reference. Compliance determinations do not take into account measurement uncertainties for each testing system, but are based on the results of the compliance measurement.

## Revision History

---

Version	Description	Issued Date
V1.0	Initial issue of report	2024/07/19

---

**Summary of Test Result**

---

Report Clause	Test Items	Result (PASS/FAIL)	Remark
5	DFS: In-Service Monitoring for Channel Move Time	PASS	-
5	DFS: In-Service Monitoring for Channel Closing Transmission Time	PASS	-
5	DFS: In-Service Monitoring for Non-Occupancy Period	PASS	-

**Comments and Explanations**

The declared of product specification for EUT presented in the report are provided by the manufacturer, and the manufacturer takes all the responsibilities for the accuracy of product specification.

## 1. General Information

### 1.1. EUT Description

DFS Frequency Range	5250 ~ 5350 MHz 5470 ~ 5725 MHz	
DFS Operating Frequency / Number of DFS Channels	IEEE 802.11a/n/ac (20 MHz)	5260~5320MHz / 4 Channels 5500~5700MHz / 11 Channels
	IEEE 802.11n/ac (40 MHz)	5270~5310MHz / 2 Channels 5510~5670MHz / 5 Channels
	IEEE 802.11ac (80 MHz)	5290MHz / 1 Channel 5530~5610MHz / 2 Channels
Type of Modulation	IEEE 802.11a/n	OFDM-BPSK, QPSK, 16QAM, 64QAM
	IEEE 802.11ac	OFDM-BPSK, QPSK, 16QAM, 64QAM, 256QAM,
Channel Control	Auto	
Channel Bandwidth	20/40/80MHz	

Accessories Information					
No.	Equipment Name	Brand Name	Model No.	Rating	Remark
1	SWITCHING POWER SUPPLY	KLEC	KL-WA120100-E	INPUT: 100-240V~50/60Hz 0.5A OUTPUT: 12.0V==1.0A	With power cable : Non-Shielded, 3m

Antenna Information				
Item.	Brand Name	Model No.	Type	Antenna Gain (dBi)
1	AWAN	ASP6P-100123 (Main)	COUPLE	4.28 dBi for 5150~5250 MHz 4.28 dBi for 5250~5350 MHz 3.14 dBi for 5470~5725 MHz 3.71 dBi for 5470~5725 MHz
		ASP6P-100124 (Aux)		5.91 dBi for 5150~5250 MHz 5.91 dBi for 5250~5350 MHz 5.16 dBi for 5470~5725 MHz 5.47 dBi for 5470~5725 MHz

Note: The antenna of EUT conforms to FCC 15.203.

#### For IEEE 802.11a Mode: (1TX, 1RX)

Only Ant. 0 can be used as transmitting/receiving antenna.

#### For IEEE 802.11n/ac Mode: (2TX, 2RX)

All of the antenna No. can be used as transmitting/receiving antennas.

## 1.2. EUT Information

EUT Power Type	From Adapter			
Operating Mode	<input type="checkbox"/>	Master		
	<input type="checkbox"/>	Bridge		
	<input type="checkbox"/>	Mesh		
	<input type="checkbox"/>	Client with radar detection		
	<input checked="" type="checkbox"/>	Client without radar detection		
Communication Mode	<input checked="" type="checkbox"/>	IP Based (Load Based)	<input type="checkbox"/>	Frame Based
TPC Function	<input type="checkbox"/>	With TPC Function	<input checked="" type="checkbox"/>	Without TPC Function
Weather Band (5600 ~ 5650 MHz)	<input checked="" type="checkbox"/>	With 5600 ~ 5650 MHz	<input type="checkbox"/>	Without 5600 ~ 5650 MHz
Beamforming Function	<input type="checkbox"/>	With beamforming	<input checked="" type="checkbox"/>	Without beamforming

## 1.3. Testing Location Information

USA	FCC Designation Number: TW0033
Canada	CAB Identifier Number: TW3023 / Company Number: 26930

Site Description	Accredited by TAF
	Accredited Number: 3023

Test Laboratory	DEKRA Testing and Certification Co., Ltd.
	Linkou Laboratory
Address	No.5-22, Ruishukeng Linkou District, New Taipei City, 24451, Taiwan, R.O.C.
Performed Location	No. 26, Huaya 1st Rd., Guishan Dist., Taoyuan City 333411, Taiwan, R.O.C.
Phone Number	+886-3-275-7255
Fax Number	+886-3-327-8031

Ambient conditions in the laboratory:

Performed Item	Items	Required	Actual	Test Date
Conducted Emission	Temperature (°C)	10~40 °C	24.7 °C	2024/05/27
	Humidity (%RH)	10~90 %	53.2 %	

#### 1.4. Measurement Uncertainty

Uncertainties have been calculated according to the DEKRA internal document with the emissions test results be included in the report. The measurement uncertainties given below are based on a 95% confidence level (based on a coverage factor (k=2)).

Test item	Uncertainty
Timing	±0.53 %

#### 1.5. List of Test Equipment

Dynamic Frequency Selection (DFS) / HY-SR05

	Equipment	Manufacturer	Model No.	Serial No.	Cal. Date	Due Date
V	Spectrum Analyzer	KEYSIGHT	N9010A	MY54510317	2023/08/09	2024/08/08
V	Vector Signal Generator	R&S	SMBV100A	261757	2024/01/05	2025/01/04

Note:

1. All equipments are calibrated every one year.
2. The test instruments marked with "V" are used to measure the final test results.



## 2. Test Configuration of EUT

### 2.1. Test Condition

EUT Operational Condition	
Testing Voltage	AC 120V/60Hz

### 2.2. Test Channel Frequencies Configuration

IEEE Std.	Test Channel Frequency
802.11ac (80 MHz)	5530 MHz

### 2.3. Measurement Configuration

Tests Item	Dynamic Frequency Selection (DFS)
Test Condition	The EUT shall be configured to operate at the highest transmitter output power setting. If more than one antenna assembly is intended for this power setting, the gain of the antenna assembly with the lowest gain shall be used.

Note:

- Determining compliance shall be based on the results of the compliance measurement, not taking into account measurement instrumentation uncertainty.

### 2.4. Tested System Details

Instrument	Manufacturer	Type No.	Serial No
Splitter/Combiner (Qty: 2)	Mini-Circuits	ZFRSC-123-S+	SN331000910
Notebook PC	Dell	N/A	N/A
ATT	Mini-Circuits	15542	30912
ATT	Mini-Circuits	15542	30909
4 WAY Divider	WOKEN	0120A04056002D	151101
Rotary ATT (Qty: 2)	WOKEN	00801A1GGAM02Y	SMA 0-121dB
Access Point	ASUS	RT-AX88U	JCITHP000040

Software	Manufacturer	Function
N7607C Signal Studio for DFS Radar Profile, Version: 2.4.0.0	KEYSIGHT	Radar Signal Generation Software
Iperf v2.0.8	iperf.fr	Streaming data

## 2.5. Standard Requirement

### FCC Part 15.407:

U-NII devices operating in the 5.25 ~ 5.35 GHz band and the 5.47 ~ 5.725 GHz band shall employ a TPC mechanism. The U-NII device is required to have the capability to operate at least 6 dB below the mean EIRP value of 30 dBm. A TPC mechanism is not required for systems with an E.I.R.P. of less than 500mW.

U-NII devices operating in the 5.25 ~ 5.35 GHz and 5.47 ~ 5.725 GHz bands shall employ a DFS radar detection mechanism to detect the presence of radar systems and to avoid co-channel operation with radar systems.

## 2.6. UNII Device Description

- (1) The EUT operates in the following DFS band:
  1. 5250 ~ 5350 MHz
  2. 5470 ~ 5725 MHz
  
- (2) Below are the available 50 ohm antenna assemblies and their corresponding gains. 0dBi gain was used to set the -63 dBm threshold level (-64dBm +1 dB) during calibration of the test setup.
  
- (3) WLAN traffic is generated by the test software "Iperf.exe" from the Master device to the Slave device in the transfer data rate >17%.
  
- (4) For the 5250 ~ 5350 MHz and 5470 ~ 5725 MHz bands, the Master device provides, on aggregate, uniform loading of the spectrum across all devices by selecting an operating channel among the available channels using a random algorithm.

### 3. General DFS Information

#### 3.1. Test Setup

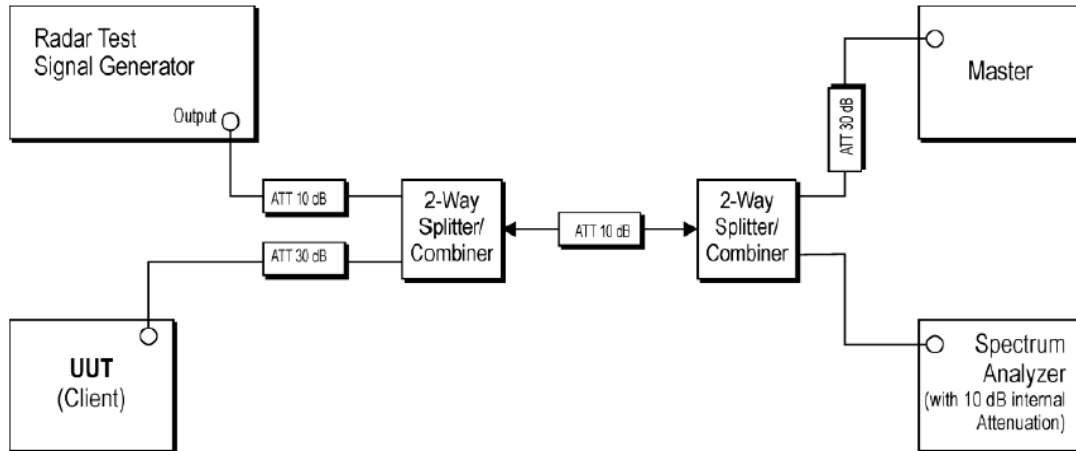

#### 3.2. DFS Detection Thresholds

##### (1) Interference Threshold value, Master or Client incorporating In-Service Monitoring

Maximum Transmit Power	Value (see note)
$\geq 200$ milliwatt	-64dBm
EIRP < 200 milliwatt and power spectral density < 10 dBm/MHz	-62dBm
EIRP < 200 milliwatt that do not meet the power spectral density requirement	-64dBm
Note 1: This is the level at the input of the receiver assuming a 0 dBi receive antenna Note 2: Throughout these test procedures an additional 1 dB has been added to the amplitude of the test transmission waveforms to account for variations in measurement equipment. This will ensure that the test signal is at or above the detection threshold level to trigger a DFS response. Note3: EIRP is based on the highest antenna gain. For MIMO devices refer to KDB Publication 662911 D01.	

**(2) DFS Response requirement values**

Parameter	Value
Non-Occupancy Period	Minimum 30 Minutes
Channel Availability Check Time	60 Seconds
Channel Move Time	10 Seconds (See Note 1)
Channel Closing Transmission Time	200 milliseconds + approx. 60 milliseconds over remaining 10 seconds period (See Note 1 and Note 2)
U-NII Detection Bandwidth	Minimum 100% of the 99% power bandwidth (See Note 3)
<p>Note 1: Channel Move Time and the Channel Closing Transmission Time should be performed with Radar Type 0. The measurement timing begins at the end of the Radar Type 0 burst.</p> <p>Note 2: The Channel Closing Transmission Time is comprised of 200 milliseconds starting at the beginning of the Channel Move Time plus any additional intermittent control signals required to facilitate a Channel move (an aggregate of 60 milliseconds) during the remainder of the 10 second period. The aggregate duration of control signals will not count quiet periods in between transmissions.</p> <p>Note 3: During the U-NII Detection Bandwidth detection test, radar type 0 should be used. For each frequency step the minimum percentage of detection is 90 percent. Measurements are performed with no data traffic.</p>	

#### 4. Radar Test Waveforms

This section provides the parameters for required test waveforms, minimum percentage of successful detections, and the minimum number of trials that must be used for determining DFS conformance. Step intervals of 0.1 microsecond for Pulse Width, 1 microsecond for PRI, 1 MHz for chirp width and 1 for the number of pulses will be utilized for the random determination of specific test waveforms.

##### (1) Short Pulse Radar Test Waveforms

Radar Type	Pulse Width (μsec)	PRI (μsec)	Number of Pulses	Minimum Percentage of Successful Detection	Minimum Number of Trials
0	1	1428	18	See Note 1	See Note 1
1	1	Test A: 15 unique PRI values randomly selected from the list of 23 PRI values in Table 5a Test B: 15 unique PRI values randomly selected within the range of 518-3066μsec, with a minimum increment of 1μsec, excluding PRI values selected in Test A	$\text{Roundup} = \left\{ \begin{array}{l} \left( \frac{1}{360} \right) \cdot \\ \left( \frac{19 \cdot 10^6}{\text{PRI}_{\mu\text{sec}}} \right) \end{array} \right\}$	60%	30
2	1-5	150-230	23-29	60%	30
3	6-10	200-500	16-18	60%	30
4	11-20	200-500	12-16	60%	30
Aggregate(Radar Types 1-4)				80%	120
Note 1: Short Pulse Radar Type 0 should be used for the detection bandwidth test, channel move time, and channel closing time tests.					

A minimum of 30 unique waveforms are required for each of the Short Pulse Radar Types 2 through 4. If more than 30 waveforms are used for Short Pulse Radar Types 2 through 4, then each additional waveform must also be unique and not repeated from the previous waveforms. If more than 30 waveforms are used for Short Pulse Radar Type 1, then each additional waveform is generated with Test B and must also be unique and not repeated from the previous waveforms in Tests A or B.

**(2) Long Pulse Radar Test Signal**

Radar Waveform	Bursts	Number of Pulses Per Burst	Pulse Width (usec)	Chirp Width (MHz)	PRI (usec)	Minimum Percentage of Successful Detection	Minimum Trials
5	8-20	1-3	50-100	5-20	1000-2000	80%	30

The parameters for this waveform are randomly chosen. Thirty unique waveforms are required for the long pulse radar test signal. If more than 30 waveforms are used for the long pulse radar test signal, then each additional waveform must also be unique and not repeated from the previous waveforms.

**Each waveform is defined as follows:**

- 1) The transmission period for the Long Pulse Radar test signal is 12 seconds.
- 2) There are a total of 8 to 20 Bursts in the 12 second period, with the number of Bursts being randomly chosen. This number is Burst Count.
- 3) Each Burst consists of 1 to 3 pulses, with the number of pulses being randomly chosen. Each Burst within the 12 second sequence may have a different number of pulses.
- 4) The pulse width is between 50 and 100 microseconds, with the pulse width being randomly chosen. Each pulse within a Burst will have the same pulse width. Pulses in different Bursts may have different pulse widths.
- 5) Each pulse has a linear frequency modulated chirp between 5 and 20 MHz, with the chirp width being randomly chosen. Each pulse within a transmission period will have the same chirp width. The chirp is centered on the pulse. For example, with a radar frequency of 5300 MHz and a 20 MHz chirped signal, the chirp starts at 5290 MHz and ends at 5310 MHz.
- 6) If more than one pulse is present in a Burst, the time between the pulses will be between 1000 and 2000 microseconds, with the time being randomly chosen. If three pulses are present in a Burst, the time between the first and second pulses is chosen independently of the time between the second and third pulses.
- 7) The 12 second transmission period is divided into even intervals. The number of intervals is equal to Burst Count. Each interval is of length  $(12,000,000 / \text{Burst Count})$  microseconds. Each interval contains one Burst. The start time for the Burst, relative to the beginning of the interval, is between 1 and  $[(12,000,000 / \text{Burst Count}) - (\text{Total Burst Length}) + (\text{One Random PRI Interval})]$  microseconds, with the start time being randomly chosen. The step interval for the start time is 1 microsecond. The start time for each Burst is chosen independently.

**A representative example of a Long Pulse radar test waveform:**

- 1) The total test signal length is 12 seconds.
- 2) 8 Bursts are randomly generated for the Burst Count.
- 3) Burst 1 has 2 randomly generated pulses.
- 4) The pulse width (for both pulses) is randomly selected to be 75 microseconds.
- 5) The PRI is randomly selected to be at 1213 microseconds.
- 6) Bursts 2 through 8 are generated using steps 3 – 5.
- 7) Each Burst is contained in even intervals of 1,500,000 microseconds. The starting location for Pulse 1, Burst 1 is randomly generated (1 to 1,500,000 minus the total Burst 1 length + 1 random PRI interval) at the 325,001 microsecond step. Bursts 2 through 8 randomly fall in successive 1,500,000 microsecond intervals (i.e. Burst 2 falls in the 1,500,001 – 3,000,000 microsecond range).

**Graphical Representation of a Long Pulse radar Test Waveform**

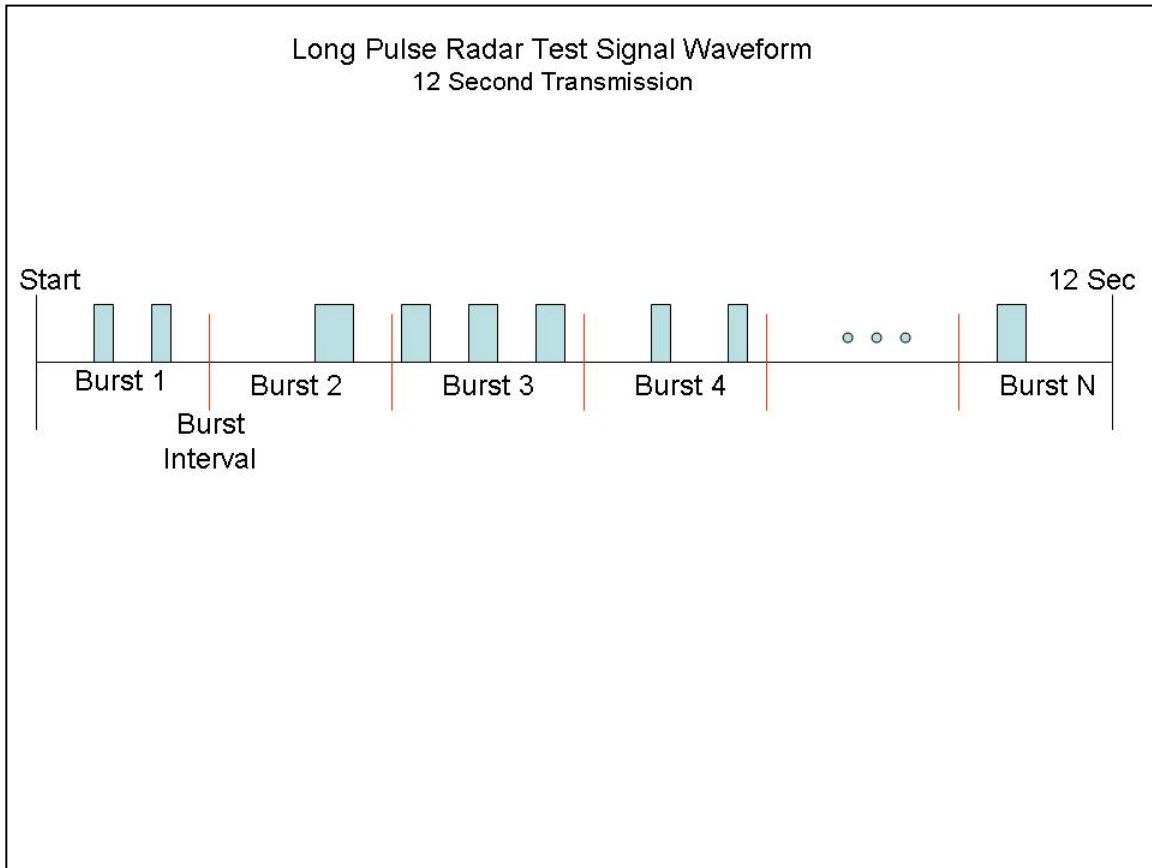

**(3) Frequency Hopping Radar Test Signal**

Radar Waveform	Pulse Width ( $\mu\text{sec}$ )	PRI ( $\mu\text{sec}$ )	Hopping Sequence Length (msec)	Pulses Per Hop	Hopping Rate (kHz)	Minimum Percentage of Successful Detection	Minimum Trials
6	1	333	300	9	0.333	70%	30

For the Frequency Hopping Radar Type, the same *Burst* parameters are used for each waveform. The hopping sequence is different for each waveform and a 100-length segment is selected from the hopping sequence defined by the following algorithm:

The first frequency in a hopping sequence is selected randomly from the group of 475 integer frequencies from 5250 – 5724 MHz. Next, the frequency that was just chosen is removed from the group and a frequency is randomly selected from the remaining 474 frequencies in the group. This process continues until all 475 frequencies are chosen for the set. For selection of a random frequency, the frequencies remaining within the group are always treated as equally likely.

#### 4.1. Radar Waveform Calibration

The following equipment setup was used to calibrate the conducted radar waveform. A spectrum analyzer was used to establish the test signal level for each radar type. During this process there were replace 50ohm terminal from master and client device and no transmissions by either the master or client device. The spectrum analyzer was switched to the zero span (time domain) at the frequency of the radar waveform generator. Peak detection was utilized. The spectrum analyzer resolution bandwidth (RBW) and video bandwidth (VBW) were set to 3MHz and 3MHz.

The signal generator amplitude was set so that the power level measured at the spectrum analyzer was -64dBm due to the interference threshold level is not required.

##### Conducted Calibration Setup

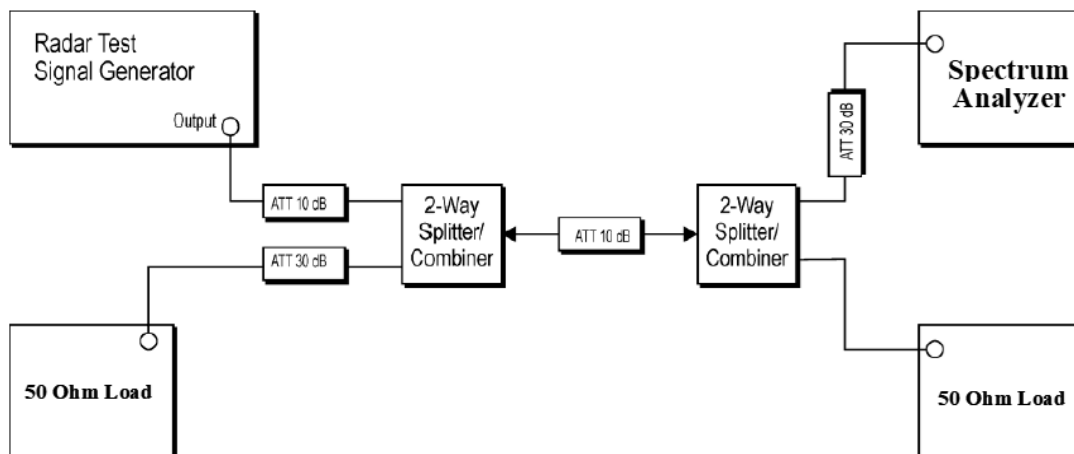



## 4.2. Test Result of Radar Waveform Calibration

Refer as Appendix A

### **4.3. Test Result of Master Data Traffic Plot**

Refer as Appendix B

## 5. In-Service Monitoring for Channel Move Time, Channel Closing Transmission Time and Non-Occupancy Period

### 5.1. Test Procedure

The EUT was tested according to U-NII test procedure of KDB905462 D02 for compliance to FCC 47CFR 15.407 requirements.

These tests define how the following DFS parameters are verified during In-Service Monitoring; Channel Closing Transmission Time, Channel Move Time, and Non-Occupancy Period. The steps below define the procedure to determine the above mentioned parameters when a radar Burst with a level equal to the DFS Detection Threshold + 1 dB (-63 dBm) is generated on the Operating Channel of the U-NII device.

A U-NII device operating as a Client Device will associate with the UUT (Master) at test channel frequency. Stream the MPEG test file from the Master Device to the Client Device on the selected Channel for the entire period of the test.

At time T0 the Radar Waveform generator sends a Burst of pulses for each of the radar types at -63 dBm. Observe the transmissions of the UUT at the end of the radar Burst on the Operating Channel for duration greater than 10 seconds. Measure and record the transmissions from the UUT during the observation time (Channel Move Time). Compare the Channel Move Time and Channel Closing Transmission Time results to the limit defined in the DFS Response requirement values table.

Measure the UUT for more than 30 minutes following the channel close/move time to verify that the UUT does not resume any transmissions on this Channel.

### 5.2. Test Requirement

Parameter	Value
Channel Move Time	10 Seconds
Channel Closing Transmission Time	200 milliseconds + approx. 60 milliseconds over remaining 10 seconds period
Non-Occupancy Period	Minimum 30 minutes

### **5.3. Test Result of Channel Move Time and Channel Closing Transmission Time**

Refer as Appendix C

#### **5.4. Test Result of Non-Occupancy Period**

Refer as Appendix D