



## PROA7PLUS / PROA7 Security System

### Installation and Setup Guide

This Quick Installation Guide provides the basic steps to quickly and easily install the Burglar and Fire Alarm Control Panel, using the built-in programming defaults. The control is designed to be placed on a desk/table top with the optional stand attached or mounted to a wall using the wall mount.

#### STEP 1 - Installing the Rechargeable Backup Battery and Power Connector

1. Remove the Control's left and right side covers.
2. Install the PROWIFIZW (Wi-Fi® and Z-Wave®), PROLTE-Series (LTE) Communications and/or PROTAKEOV Wireless Converter modules (if required).
3. Insert the Battery Pack into the case.
4. Connect the battery connector to the receptacle on the PC board.
- 5a. Connect the power cable to the GND and +9V terminals on the wall mount and to the + and - terminals on the Power Supply. Refer to Table 1 for wire gauge and length. **Do not apply power at this time.** OR
- 5b. Connect the power supply connector to the receptacle on the desk mount. **Do not apply power at this time.**

**NOTE:** If using the optional wall mount configuration, skip to the wall mounting procedure. If using the PROA7DM Desk Mount refer to the Installation Guide P/N 800-25157.

**Optional PROWIFIZW, PROLTE-Series and PROTAKEOV Communications Module**  
**Note:** Refer to the *Specific Module Installation* section in the online *Installation & Reference Guide* for installation instructions.

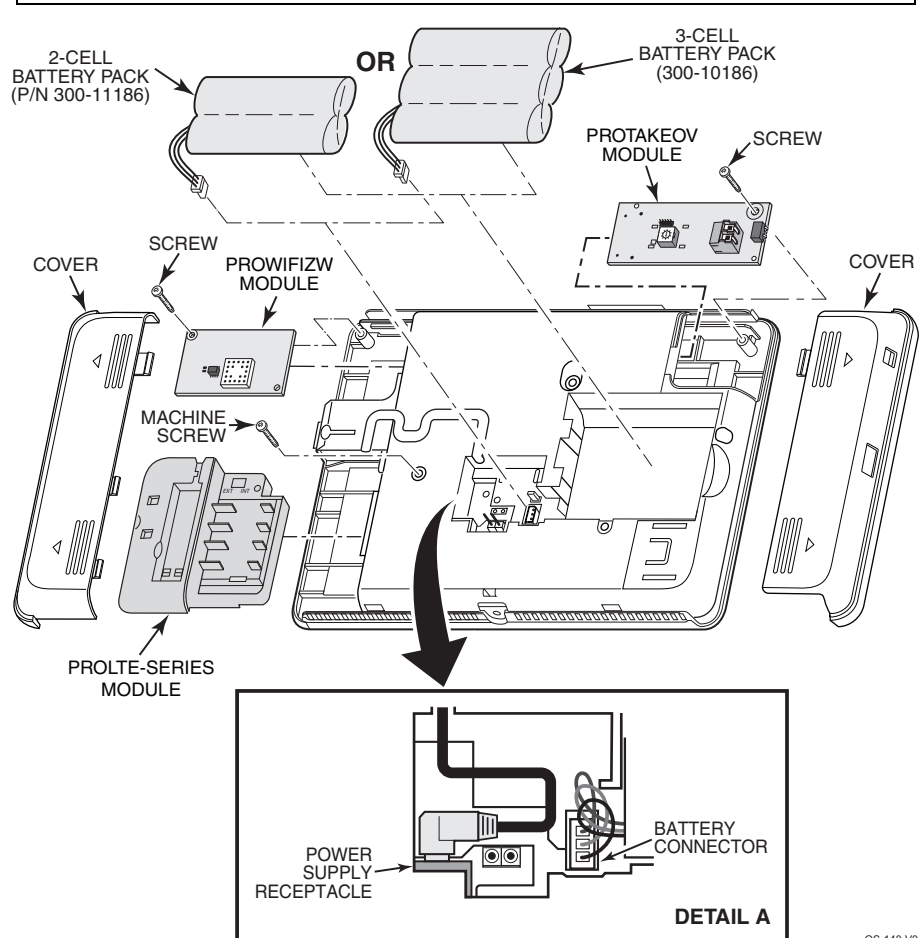

**Table 1 – Wiring Guide**

Maximum distance between power supply and control	Wire Gauge (AWG)
Up to 25 feet (7.62m)	# 22
Up to 45 feet (13.72m)	# 20
Up to 70 feet (21.34m)	# 18
Up to 110 feet (33.53m)	# 16

**Note:** Use UL-listed limited energy cable

#### Mounting the Base to a Wall (Optional)

For wall mounting, perform the following:

1. Secure the Mounting Plate to the wall with 4 screws.
2. Install the Tamper Screw as shown (if required).
3. Secure the Control to the Mounting Plate by aligning the slots on the wall mount and sliding the unit up until tabs on the wall mount are engaged. Then push it toward the wall until to lock it in place.
4. Secure the Control with the set screw.

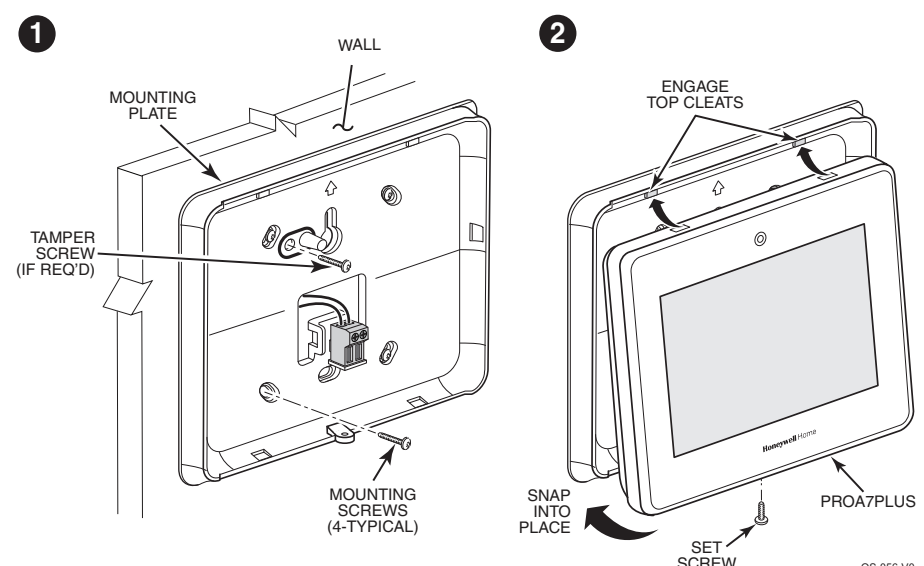

#### STEP 2 - Setting up the Communication Links

**Note:** Do not connect to a receptacle controlled by a switch.

1. Plug the power supply into a 24-hour, 110VAC unswitched outlet. Upon power-up, the "Please Standby!" will be displayed on the home screen.
2. Settings → Wi-Fi → Master User Code → Wi-Fi Networks OR Add networks Manually OR WPS → Enter required information OR follow prompts → Save

#### STEP 3 - Registration Programming and Testing

Registration, Programming and Testing is conducted through AlarmNet 360™. On a laptop, PC or Smart Device, go to: [www.alarmnet360.com](http://www.alarmnet360.com) or the AlarmNet360 App.

**IMPORTANT:** Once the programming procedure has started and the unit is powered up, do not remove power, disconnect the battery, or open the case. Disconnecting power or activating the tamper switch can cause unpredictable programming results.

#### Testing the System

The following test modes are available:

- Test Sensors (Walk Test)
- Test Communicator

#### Enter Test mode (Walk Test)

1. Select **Test** and enter the Master User Code.
2. Select **System Tests**.
3. Select Test Sensors. The system enters Walk Test mode. Follow the prompts.
4. Open each protected door and listen for three beeps from the keypad, followed by the zone's Voice Descriptor. Identification of each faulted protection point, battery and signal strength appears on the display.
5. Walk in front of the motion sensor and listen for three beeps and the zone's voice descriptor.
6. Press each key on the keyfob to confirm it performs its assigned function.
7. When testing is complete, select **End Test** and follow the prompts.
8. Select the small icon to return to the home screen.

#### Shutting Down the System

To avoid corrupting the control's memory, before removing power from the system:

1. Disarm the system.
2. Wait 30 seconds.
4. Unplug the power supply.
5. Disconnect the battery.

#### Features and Capacities

Feature	Details	PROA7PLUS	PROA7
Partitions	4	•	•
Maximum Devices	<ul style="list-style-type: none"> <li>• 250 Intrusion/Fire Zones                             <ul style="list-style-type: none"> <li>- 127 SiX Series devices (sensors, keyfobs, keypads)</li> <li>- 250 5800 series devices (requires PROTAKEOV module)*</li> </ul> </li> <li>• 32 SiX Series Keyfobs</li> <li>• 8 SiX Series Keypads/ Touchscreens</li> <li>• Built-in Camera</li> </ul>	•	•
Z-Wave	Supports up to 78 Z-Wave devices with the following maximums: Light Modules ..... 60 Garage Doors ..... 6 Door Locks:..... 6 Z-Wave Thermostats*:..... 6 Wi-Fi Thermostats*:..... 4 * Combination Z-Wave & Wi-Fi thermostats maximum..... 6	•	•
Bluetooth	Smartphone disarming via Bluetooth	•	---
Wiselink	Wiselink compatibility with PROINDMV and PROOUTMV Motion Viewers	•	---
Security Codes	96 User Codes (Includes Master User #1)	•	•
Event Log	4,000 events	•	•

\* The PROTAKEOV module supports communication with certain previously installed wireless sensors and modules. Refer to PROTAKEOV Compatibility chart (p/n R800-26221A or later) for a list of tested and approved vendor wireless devices.

#### Specifications

<b>Dimensions:</b>	7.875" W x 5.75" H x 1.0" D
<b>Voltage Input:</b>	P/N 300-10260 – 9VDC, 2.5A P/N 300-10260-CAN (Canada) – 9VDC, 2.5A
<b>24-Hour Backup Battery:</b>	P/N 300-10186: Rechargeable Backup Battery: Lithium-ion battery pack rated at 3.6/4.2V, 7500 mAH P/N 300-11186: Rechargeable Backup Battery: Lithium-ion battery pack rated at 3.6/4.2V, 5200 mAH

#### Contacting Technical Support

**PLEASE, before you call Technical Support, be sure you:**

READ THE INSTRUCTIONS!

- Determine that the power supply and/or backup battery are supplying proper voltages.
- Verify your programming information where applicable.
- Note the proper model number of this product, and the version level (if known) along with any documentation that came with the product.
- Note your Honeywell Home customer number and/or company name.

Keeping this information handy will make it easier for us to serve you quickly and effectively. For technical support please call 1-800-645-7492

**This system must be checked by a qualified technician at least once every three (3) years.**

## The Limitations of this Alarm System

While this system is an advanced design security system, it does not offer guaranteed protection against burglary or fire or other emergency. Any alarm system, whether commercial or residential, is subject to compromise or failure to warn for a variety of reasons. For example:

- Intruders may gain access through unprotected openings or have the technical sophistication to bypass an alarm sensor or disconnect an alarm warning device.
- Intrusion detectors (e.g., passive infrared detectors), smoke detectors, and many other sensing devices will not work without power. Battery-operated devices will not work without batteries, with dead batteries, or if the batteries are not put in properly. Devices powered solely by AC will not work if their AC power supply is cut off for any reason, however briefly.
- Signals sent by wireless transmitters may be blocked or reflected by metal before they reach the alarm receiver. Even if the signal path has been recently checked during a weekly test, blockage can occur if a metal object is moved into the path.
- A user may not be able to reach a panic or emergency button quickly enough.
- While smoke detectors have played a key role in reducing residential fire deaths in the United States, they may not activate or provide early warning for a variety of reasons in as many as 35% of all fires, according to data published by the Federal Emergency Management Agency. Some of the reasons smoke detectors used in conjunction with this System may not work are as follows. Smoke detectors may have been improperly installed and positioned. Smoke detectors may not sense fires that start where smoke cannot reach the detectors, such as in chimneys, in walls, or roofs, or on the other side of closed doors. Smoke detectors also may not sense a fire on another level of a residence or building. A second-floor detector, for example, may not sense a first-floor or basement fire. Moreover, smoke detectors have sensing limitations. No smoke detector can sense every kind of fire every time. In general, detectors may not always warn about fires caused by carelessness and safety hazards like smoking in bed, violent explosions, escaping gas, improper storage of flammable materials, overloaded electrical circuits, children playing with matches, or arson. Depending upon the nature of the fire and/or the locations of the smoke detectors, the detector, even if it operates as anticipated, may not provide sufficient warning to allow all occupants to escape in time to prevent injury or death
- Passive Infrared Motion Detectors can only detect intrusion within the designed ranges as diagrammed in their installation manual. Passive Infrared Detectors do not provide volumetric area protection. They do create multiple beams of protection, and intrusion can only be detected in unobstructed areas covered by those beams. They cannot detect motion or intrusion that takes place behind walls, ceilings, floors, closed doors, glass partitions, glass doors, or windows. Mechanical tampering, masking, painting or spraying of any material on the mirrors, windows or any part of the optical system can reduce their detection ability. Passive Infrared Detectors sense changes in temperature; however, as the ambient temperature of protected area approaches the temperature range of 90° to 105°F, the detection performance can decrease.
- Alarm warning devices such as sirens, bells, or horns may not alert people or wake up sleepers if they are located on the other side of closed or partly open doors. If warning devices sound on a different level of the residence from the bedrooms, then they are less likely to waken or alert people inside the bedrooms. Even persons who are awake may not hear the warning if the alarm is muffled from a stereo, radio, air conditioner or other appliance, or by passing traffic. Finally, alarm warning devices, however loud, may not warn hearing-impaired people or waken deep sleepers.
- Even if the system responds to the emergency as intended, however, occupants may have insufficient time to protect themselves from the emergency situation. In the case of a monitored alarm system, authorities may not respond appropriately.
- This equipment, like other electrical devices, is subject to component failure. Even though this equipment is designed to last as long as 10 years, the electronic components could fail at any time.

The most common cause of an alarm system not functioning when an intrusion or fire occurs is inadequate maintenance. This alarm system should be tested weekly to make sure all sensors and transmitters are working properly.

Installing an alarm system may make one eligible for lower insurance rates, but an alarm system is not a substitute for insurance. Homeowners, property owners, and renters should continue to act prudently in protecting themselves and continue to insure their lives and property.

We continue to develop new and improved protection devices. Users of alarm systems owe it to themselves and their loved ones to learn about these developments.

## RF Exposure

**Warning** – The antenna(s) used for this device must be installed to provide a separation distance of at least 7.8 inches (20 cm) from all persons and must not be co-located or operating in conjunction with any other antenna or transmitter except in accordance with FCC and ISED multi-transmitter product procedures.

## Mise en Garde

**Exposition aux Fréquences Radio:** La/les antenne(s) utilisée(s) pour cet émetteur doit/doivent être installée(s) à une distance de séparation d'au moins 20 cm (7,8 pouces) de toute personne et ne pas être située(s) ni fonctionner parallèlement à tout autre transmetteur ou antenne, excepté en conformité avec les procédures de produit multi transmetteur FCC et ISEDs.

This equipment should be installed in accordance with National Electrical Code, NFPA 70, Standard for the Installation of Residential Fire Warning Systems, CAN/ULC-S540 and Chapter 2 of the National Fire Alarm Code, ANSI/NFPA 72 (National Fire Protection Association, Batterymarch Park, Quincy, MA 02269). Printed information describing proper installation, operation, testing, maintenance, evacuation planning, and repair service is to be provided with this equipment.

**Warning:** Owner's instruction notice: 'Not to be removed by anyone except occupant

**Avertissement :** Avis du propriétaire : « Ne doit être retiré par personne, sauf l'occupant. »

**Warning:** this unit includes an alarm verification feature that will result in a delay of the system alarm signal from the indicated circuits. The total delay (control unit plus smoke detectors) shall not exceed 60 seconds. No other smoke detector shall be connected to these circuits unless approved by the local authority having jurisdiction.

**Avertissement:** Cette unité peut être programmée pour utiliser une fonction de vérification d'alarme d'incendie qui entraîne un délai dans la signalisation des alarmes provenant des circuits dédiés à l'incendie. Le délai total (unité de commande et détecteurs de fumée) ne doit pas dépasser 60 secondes. Aucun autre détecteur de fumée ne doit être raccordé à ces circuits sans l'approbation des autorités compétentes locales.

**Note** Each protected circuit within this control is supervised.

## SUPPORT & WARRANTY

See Installation and Setup Guide P/N 800-25082 or higher.  
For the latest documentation and online support information, please go to:  
[www.resideo.com](http://www.resideo.com)

For the latest warranty information, please go to:  
[www.security.honeywellhome.com/warranty](http://www.security.honeywellhome.com/warranty)

## Recommendations for Proper Protection

The Following Recommendations for the Location of Fire and Burglary Detection Devices Help Provide Proper Coverage for the Protected Premises.

### Recommendations for Smoke and Heat Detectors

With regard to the number and placement of smoke/heat detectors, we subscribe to the recommendations contained in the National Fire Protection Association's (NFPA) Standard #72 noted below.

Early warning fire detection is best achieved by the installation of fire detection equipment in all rooms and areas of the household as follows: For minimum protection a smoke detector should be installed outside of each separate sleeping area, and on each additional floor of a multi-floor family living unit, including basements. The installation of smoke detectors in kitchens, attics (finished or unfinished), or in garages is not normally recommended.

For additional protection the NFPA recommends that you install heat or smoke detectors in the living room, dining room, bedroom(s), kitchen, hallway(s), attic, furnace room, utility and storage rooms, basements and attached garages.

In addition, we recommend the following:

- Install a smoke detector inside every bedroom where a smoker sleeps.
- Install a smoke detector inside every bedroom where someone sleeps with the door partly or completely closed. Smoke could be blocked by the closed door. Also, an alarm in the hallway outside may not wake up the sleeper if the door is closed.
- Install a smoke detector inside bedrooms where electrical appliances (such as portable heaters, air conditioners or humidifiers) are used.
- Install smoke detectors at both ends if the hallway is more than 40 feet (12 meters) long.
- Install smoke detectors in any room where an alarm control is located, or in any room where alarm control connections to an AC source or phone lines are made. If detectors are not so located, a fire within the room could prevent the control from reporting a fire or an intrusion.

### This Control Complies with NFPA Requirements for Temporal Pulse Sounding of Fire Notification Appliances

### Recommendations for Proper Intrusion Protection

- For proper intrusion coverage, sensors should be located at every possible point of entry to a home or premises. This would include any skylights that may be present, and the upper windows in a multi-level building.
- In addition, we recommend that radio backup be used in a security system. This will ensure that alarm signals can be sent to the alarm monitoring station in the event that the communications are out of order (if connected to an alarm monitoring station).

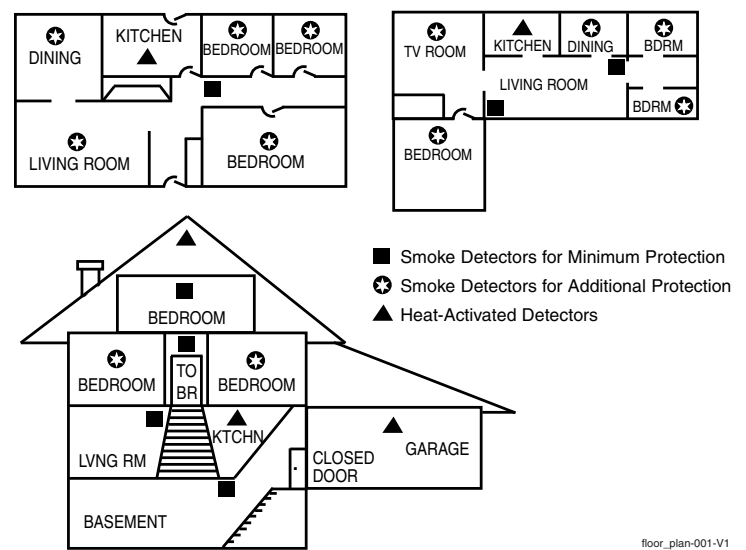

## Federal Communications Commission & ISED Statements

The user shall not make any changes or modifications to the equipment unless authorized by the Installation Instructions or User's Manual. Unauthorized changes or modifications could void the user's authority to operate the equipment.

### CLASS B DIGITAL DEVICE STATEMENT

This equipment has been tested to FCC requirements and has been found acceptable for use. The FCC requires the following statement for your information:

This equipment generates and uses radio frequency energy and if not installed and used properly, that is, in strict accordance with the manufacturer's instructions, may cause interference to radio and television reception. It has been type tested and found to comply with the limits for a Class B computing device in accordance with the specifications in Part 15 of FCC Rules, which are designed to provide reasonable protection against such interference in a residential installation. However, there is no guarantee that interference will not occur in a particular installation. If this equipment does cause interference to radio or television reception, which can be determined by turning the equipment off and on, the user is encouraged to try to correct the interference by one or more of the following measures:

- If using an indoor antenna, replace it with a quality outdoor antenna.
- Reorient the receiving antenna until interference is reduced or eliminated.
- Move the radio or television receiver away from the receiver/control.
- Move the antenna leads away from any wire runs to the receiver/control.
- Plug the receiver/control into a different outlet so that it and the radio or television receiver are on different branch circuits.
- Consult the dealer or an experienced radio/TV technician for help.

### ISED CLASS B STATEMENT

This Class B digital apparatus complies with Canadian ICES-003.

Cet appareil numérique de la classe B est conforme à la norme NMB-003 du Canada.

### FCC / ISED STATEMENT

This device complies with Part 15 of the FCC Rules, and ISED's license-exempt RSSs.

Operation is subject to the following two conditions: (1) This device may not cause harmful interference, and (2) This device must accept any interference received, including interference that may cause undesired operation.

Cet appareil est conforme à la partie 15 des règles de la FCC et exempt de licence RSS ISED. Son fonctionnement est soumis aux conditions suivantes: (1) Cet appareil ne doit pas causer d'interférences nuisibles. (2) Cet appareil doit accepter toute interférence reçue y compris les interférences causant une réception indésirable.

Responsible Party / Issuer of Supplier's Declaration of Conformity: Ademco Inc., a subsidiary of Resideo Technologies, Inc., 2 Corporate Center Dr., Melville, NY 11747, Ph: 516-577-2000

The product should not be disposed of with other household waste. Check for the nearest authorized collection centers or authorized recyclers. The correct disposal of end-of-life equipment will help prevent potential negative consequences for the environment and human health.

The Honeywell Home Trademark is used under license from Honeywell International Inc. This product manufactured by Resideo Technologies, Inc. and its affiliates.