

Quick Start - Single System Setup

Press the SELECT button on the front of the CR88 receiver to choose an available channel. The channel number will increase by one digit, from 0-9 then A-F. Once the last channel has been reached, the count will cycle back to 0.

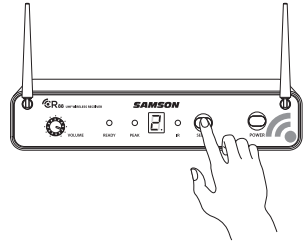

Position the transmitter about 6-12" (15-30 cm) from the front of the CR88 with the transmitter's IR window facing the IR transmitter on the front panel of the CR88 receiver.

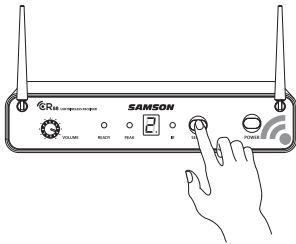

Press and hold the CR88 SELECT button to set the transmitter to the same channel as the receiver via infrared transmission

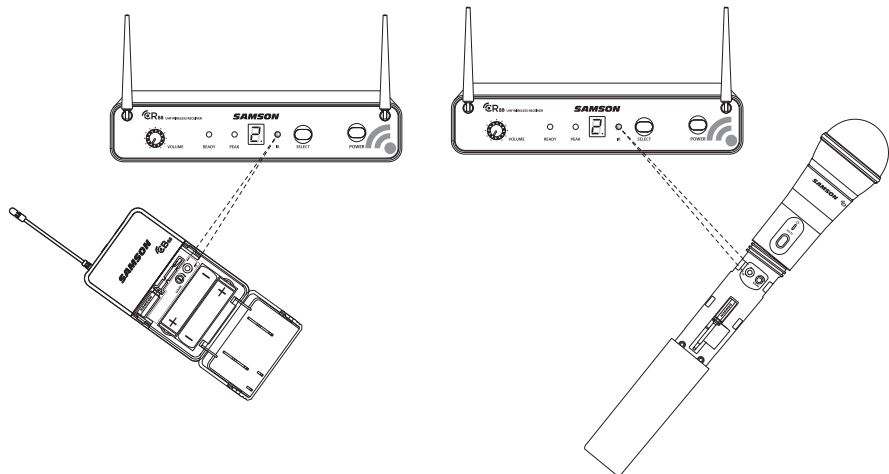

Quick Start - Single System Setup

When the transmission is complete, the CR88 will receive RF signal and the tone key from the transmitter. The READY indicator will light on the front panel of the CR88 receiver.

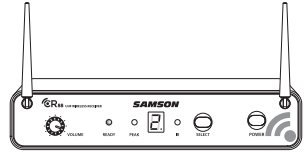

Turn on your connected amplifier or mixer, but keep the volume all the way down. Set the Volume knob on the CR88 fully clockwise (to its "10" setting). This is unity gain.

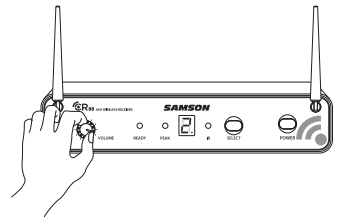

Speak or sing into the microphone, or if you are using the transmitter with a connected instrument, play the instrument at normal performance level. Slowly raise the volume of your amplifier or mixer until the desired level is reached.

If you find the system has noticeable dropouts, reduced overall working range, or unexpected noise bursts, change the operating channel of the system using the steps above.

Quick Start - Multiple System Setup

When using multiple systems, each system must be set to a different operating channel. Transmitter and receiver pairs must be on the same channel plan in order to work together (See "Concert 88 Channel Plans" on page 20).

When setting an additional transmitter, make sure to close all other transmitter battery compartments to ensure that the IR Lens is covered.

To change the operating channel of a system, press the SELECT button on the front of the CR88 receiver. The channel number will increase by one digit, from 0-9 then A-F. Once the last channel has been reached, the count will cycle back to 0.

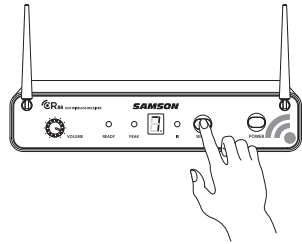

Turn on the power to the transmitter by pressing and holding the Power switch; the indicator LED will light green.

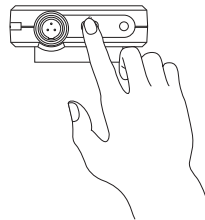
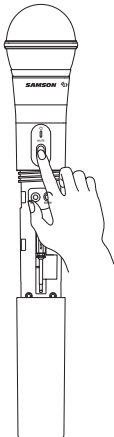

Quick Start - Multiple System Setup

Position the transmitter about 6-12" (15-30 cm) from the front of the CR88 with the transmitter's IR window facing the receiver's IR transmitter.

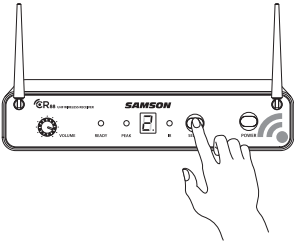

Press and hold the CR88 SELECT button to synch the transmitter to the same channel as the receiver via infrared transmission.

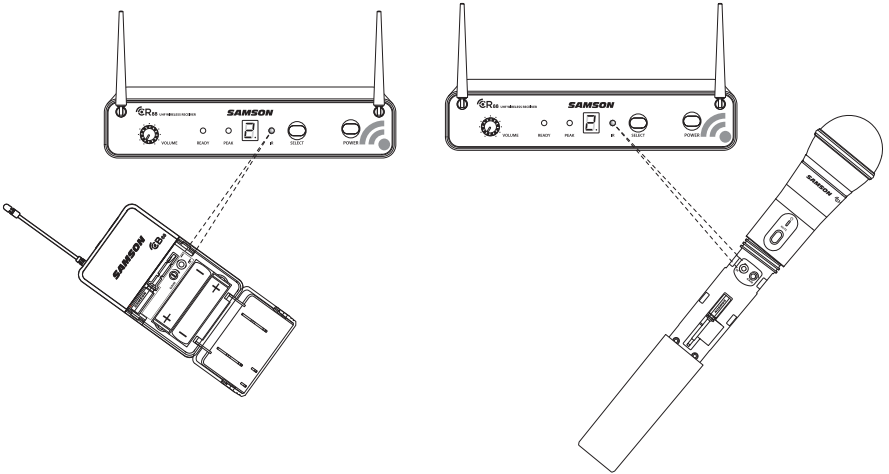

When the transmission is complete, and the CR88 is receiving RF signal from the transmitter, the READY indicator will light on the front panel of the CR88 receiver.

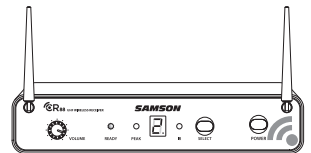

If you find the system has noticeable dropouts, reduced overall working range, or unexpected noise bursts, change the operating channel of the system using the steps above.

Rack Mounting

The CR88 receiver can be installed into a standard 19" rack for transport or permanent installation using the included rack ears. Follow the simple steps below to mount the CR88:

Attach the included rack ears by sliding each rack ear into the groove on either side of the CR88 until they lock into place, and the receiver flush with the front panel.

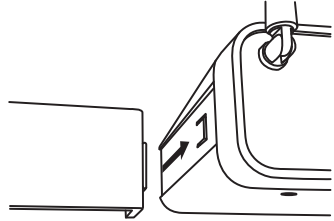

Position the CR88 receiver into an available rack space and slide in until the rack ears are touching the rails of the rack case and are aligned with the rack rail holes.

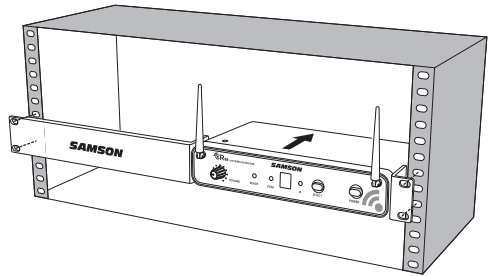

Mount the receiver into the rack using the appropriate size rack screws (not included). To ensure equal tension and balance when installing the receiver, you should secure screws in a crisscross pattern of opposite corners: top left -> bottom right -> top right -> bottom left.

In order to mount two CR88 receivers in one rack space, the system includes a center connection piece. Slide the center connection piece into the groove of each receiver and attach the short rack ears to each receiver. Mount the receivers into the rack using the crisscross pattern described above.

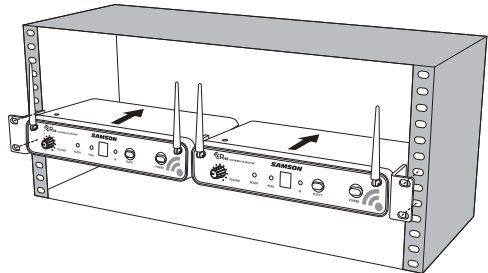

Concert 88 Channel Plans

Group C 638-662 MHz		Group D 542-566 MHz		Group F* 863-865 MHz		Group G* 606-630 MHz	
Ch	Freq	Ch	Freq	Ch	Freq	Ch	Freq
0	638.125	0	542.125	0	863.050	0	606.125
1	639.625	1	543.625	1	863.250	1	607.625
2	641.050	2	545.05	2	863.550	2	609.05
3	642.425	3	546.425	3	863.750	3	610.425
4	642.900	4	546.900	4	864.050	4	610.900
5	645.525	5	549.525	5	864.250	5	613.525
6	647.100	6	551.100	6	864.550	6	615.100
7	648.475	7	552.475	7	864.750	7	616.475
8	650.000	8	554.000	8	864.950	8	618.000
9	652.075	9	556.075			9	620.075
A	654.975	A	558.975			A	622.975
B	655.975	B	559.975			B	623.975
C	657.050	C	561.050			C	625.050
D	658.975	D	562.975			D	626.975
E	660.425	E	564.425			E	628.425
F	661.975	F	565.975			F	629.975

* Not for use in the USA. For questions regarding available channels in your area contact your local Samson distributor.

Troubleshooting

Issue	Solutions
No Audio	Make sure that the transmitter and receiver are both powered on.
	Ensure the transmitter's batteries are installed correctly.
	Check that the transmitter is not muted.
	Confirm that the CR88 adaptor is correctly connected and plugged into an electrical outlet.
	Turn on the CR88 receiver.
	Make sure the CR88 audio output connections are securely connected.
	Ensure that the receiver and transmitter are in line of sight with one another.
	Check the receiver and audio input device level controls.
	Ensure that the transmitter and receiver are set to the same operating channel. If unsure, reset the channel by performing an IR set.
Distorted Audio	The receiver output level or audio input device level may be too high.
	Check the transmitters batteries, and replace if low.
	The input gain on the transmitter (CB88) or audio source level may be too high.
Audio Dropout	The transmitter may be too far away from the receiver. Move it closer to the receiver, or reposition the antennas.
	Remove any sources that may cause RF interference such as cell phones, cordless phones, lighting equipment, computers, metal structures, etc.
Receiver will not power on	Check the adaptor to ensure it is properly connected and plugged into an outlet providing power.
Transmitter will not power on (LED lights RED)	Replace the transmitter batteries.
Unwanted noise or interference	If using multiple systems, make sure none of the systems are operating on the same channel. If the problem persists, change one or all of the systems channels.

Specifications

System

Working Range	300' (100m) line of sight
Audio Frequency Response	50 Hz - 15 kHz
T.H.D. (Overall)	<1% (@AF 1 kHz, RF 46 dBu)
Dynamic Range	>100 dB A-weighted
Signal to Noise	>90 dB
Operating Temperature	-10°C (14°F) to +40°C (+104°F)

CB88 Belt pack Transmitter

Input Connector	Mini-XLR (P3)
Input Impedance	1M Ω
Input Gain Range	38 dB
RF Power	10 mW EIRP
Power Requirements	Two AA (LR6) alkaline batteries
Battery Life	8 hours
Dimensions (HxLxD)	3.75" x 2.44" x 0.75" 96mm x 62mm x 18.5mm
Weight	0.2 lb / 93 g

CH88 Handhd Transmitter

Microphone Element	Q6 Dynamic
Input Gain Range	28 dB
RF Power	10 mW EIRP
Power Requirements	Two AA (LR6) alkaline batteries
Battery Life	8 hours
Dimensions (Hx \emptyset)	10.23" x 2.1" 260mm x 54mm
Weight	0.48 lb / 218 g

CR88 Receiver

Audio Output Level - Unbalanced	+14 dBu
Audio Output Level - Balanced	+9 dBu
Audio Output Impedance - Unbalanced	810 Ohms
Audio Output Impedance - Balanced	240 Ohms
Sensitivity	-100 dBm / 30 dB sinad
Image Rejection	>50 dB
Operating Voltage	15 VDC 200mA
Dimensions (LxWxH)	8.25" x 4.9" x 1.75" 210mm x 125mm x 44mm
Weight	0.85 lb / 388 g

At Samson, we are continually improving our products, therefore specifications and images are subject to change without notice.

FCC Rules and Regulations

Samson wireless receivers are certified under FCC Rules part 15 and transmitters are certified under FCC Rules part 74.

Licensing of Samson equipment is the user's responsibility and licensability depends on the user's classification, application and frequency selected.

NOTE: This equipment has been tested and found to comply with the limits for a Class B digital device, pursuant to Part 15 of the FCC Rules. These limits are designed to provide reasonable protection against harmful interference in a residential installation. This equipment generates, uses and can radiate radio frequency energy and, if not installed and used in accordance with the instructions, may cause harmful interference to radio communications. However, there is no guarantee that interference will not occur in a particular installation. If this equipment does cause harmful interference to radio or television reception, which can be determined by turning the equipment off and on, the user is encouraged to try to correct the interference by one or more of the following measures:

- Reorient or relocate the receiving antenna.
- Increase the separation between the equipment and receiver.
- Connect the equipment into an outlet on a circuit different from that to which the receiver is connected.
- Consult the dealer or an experienced Radio/TV technician for help.

WARNING: Changes or modifications not expressly approved by the party responsible for compliance could void the user's authority to operate the equipment.

This device complies with RSS-210 of Industry & Science Canada.

Operation is subject to the following two conditions:

(1) this device may not cause harmful interference and (2) this device must accept any interference received, including interference that may cause undesired operation.

Hereby, Samson Technologies Corp., declares that this CR88, CH88, CB88 is in compliance with the essential requirements and other relevant provisions of Directive 1999/5/EC. The declaration of conformity may be consulted at http://www.samsontech.com/site_media/support/R&TTE_DOC/CONCERT_88_R&TTE_DOC.pdf

Samson Technologies
45 Gilpin Avenue
Hauppauge, New York 11788-8816
Phone: 1-800-3-SAMSON (1-800-372-6766)
Fax: 631-784-2201
www.samsontech.com