

Operation description

NAME OF PART

Front panel :

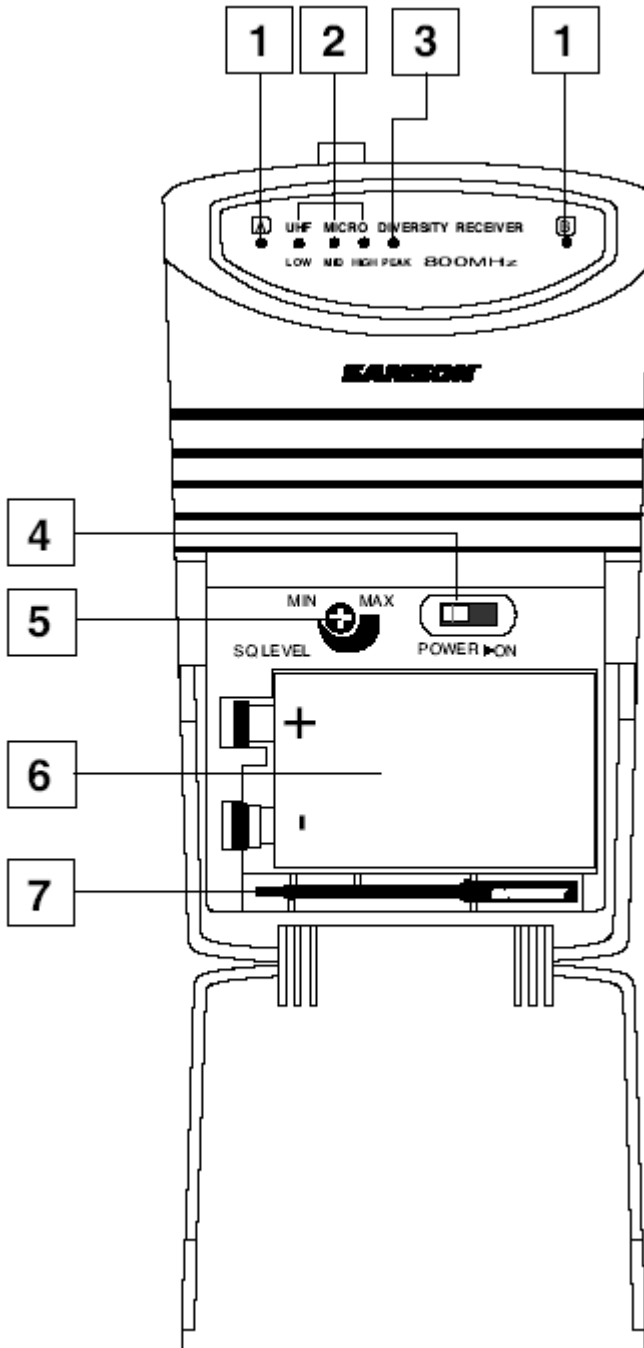

Rear panel :

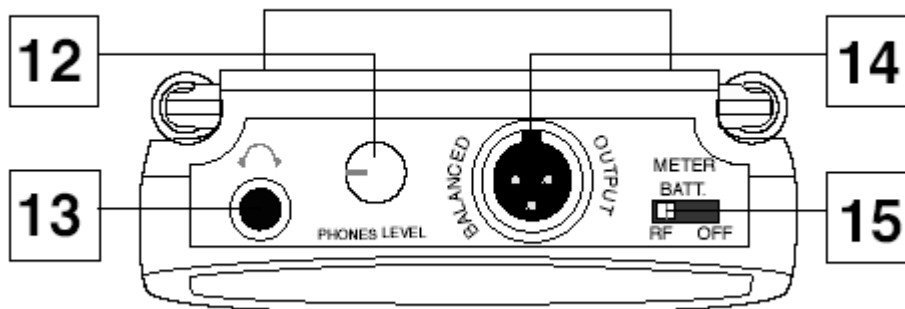
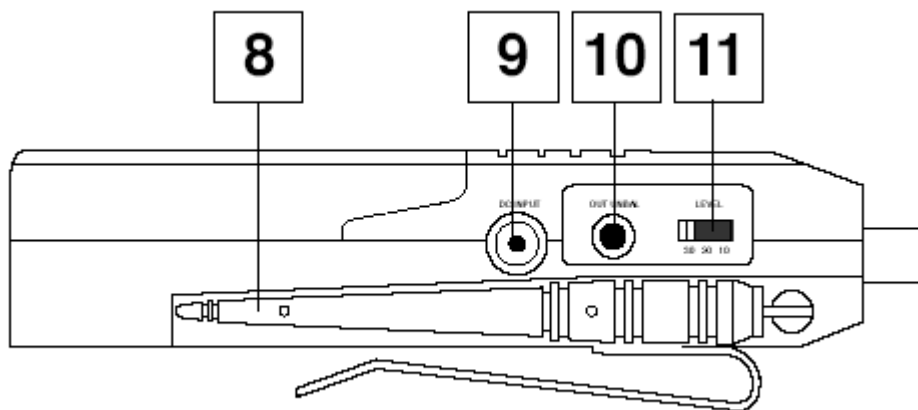

Front panel :

1: A/B Receiver LEDs - When signal is being received, one of these will be lit orange, showing you whether the (left) "A" or (right) "B" receiver is currently being used. The UM1 constantly scans its two antennas and automatically selects whichever is receiving the strongest, clearest signal. This True Diversity switching is completely inaudible, but it effectively increases overall range while virtually eliminating potential interference and phase cancellation problems.

2: Meter - This set of three multicolor LEDs acts as a meter, indicating either battery power or the strength of the incoming RF signal. This meter can also be disabled altogether to conserve battery power. See #15 on page 9 for more information.

3: Peak LED - This LED lights red when output signal from the UM1 is at the onset of clipping (that is, when it is on the verge of being distorted). If you see this light during operation, move the microphone further away or lower the output level of your instrument or transmitter. For more information, see the section entitled "Setting Up and Using the AirLine System" on page 14 in this manual.

4: Power switch - Use this to turn the UM1 power on and off.

5: SQ (Squelch) Level control - This control determines the maximum range of the UM1 before audio signal dropout. Although it can be adjusted using the supplied plastic screwdriver, it should normally be left at its factory setting. See the "Setting Up and Using the AirLine System" section on page 14 in this manual for more information.

6: Battery holder - Insert a standard 9-volt alkaline battery here, being sure to observe the plus and minus polarity markings shown. We recommend the Duracell MN 1604 type battery. Although rechargeable Ni-Cad batteries can be used, they do not supply adequate current for more than four hours.

WARNING: Do not insert the battery backwards; doing so can cause severe damage to the UM1 and will void your warranty.

7: Plastic screwdriver - Specially designed for use in adjusting the UM1 Squelch Level control (see #4 on the previous page). See the "Setting Up and Using the AirLine System" section on page 14 in this manual for more information.

Rear panel :

8: Antennas (A and B) - The antenna mountings allow full rotation for optimum placement. In normal operation, both antennas should be placed in a vertical position. Both antennas can be folded inward for convenience when transporting the UM1. See the "Setting Up and Using the AirLine" section on page 16 in this manual for more information.

9: DC input - This jack will accept a DC input voltage of 6 - 13 volts (inner connection [tip] positive, outer connection [sleeve] ground) from your video camera, if available. Connect an optional Samson AC300R adapter here to charge a rechargeable 9-volt Ni-Cad battery.

10: Unbalanced output* - Use this unbalanced (1K Ohm max.) 1/8" (3.5 mm) mini-phone jack when connecting the UM1 to consumer (-10) audio equipment. Wiring is as follows: tip hot, sleeve ground. If your video camera has stereo audio inputs, you'll need to use a Y-adaptor that has a 1/8" (3.5 mm) mini-phone plug at one end and dual male RCA-type plugs at the other end.

11: Audio Output Level switch - Sets the audio output level of both the balanced and unbalanced outputs (see #10 above and #14 on the following page) to -30 dBm (mic level), -20 dBm, or -10 dBm (line level). See the "Setting Up and Using the AirLine System" section on page 14 in this manual for more information.

12: Level control - This knob sets the level of the audio signal being sent to the headphones output (see #13 below).

13: Headphones output - Connect a stereo headphone to this standard 1/8" (3.5 mm) mini-phone jack in order to monitor the signal being output by the UM1. We recommend the use of 30 ohm headphones. The level of the headphone signal can be set by adjusting the Level control (see #12 above). Maximum output is 240 mW @ 30 ohms).

14: Balanced output* - Use this electronically balanced low impedance (600 Ohm) mini-XLR jack when connecting the UM1 to professional (+4) audio equipment. Pin wiring is as follows: Pin 1 ground, Pin 2 high (hot), and Pin 3 low (cold).

15: Meter switch - This three-position switch determines the function of the front-panel UM1 meter (see page #2 on page 9). In the left "RF" position, the meter indicates the strength of the incoming RF signal. In the center "BATTERY" position, the meter indicates relative battery power, showing whether the installed battery is at low (red), mid (yellow) or high (green) strength. (Note: When the red "low" indicator lights, performance is degraded and the battery needs to be replaced). In the right "OFF" position, the meter is disabled altogether, thus conserving battery power.

Specifications

Receiver (UM1):

Oscillation Type	Crystal Controlled
Receiving Method	Single Super Heterodyne / True Diversity
De-emphasis	50 μ sec
IF Frequency	10.7 MHz
Local Frequency	70MHz(Range) 79-79.5MHz
Antenna	1/4 Wavelength Rod
In/Out	5.5 DC Inlet, Balanced Output (Switchcraft TA3F mini-XLR), Unbalanced Output (3.5 mm phone jack), Headphone Output (3.5 mm phone jack)
Display (LED)	Receiver A/B (Orange), Peak (Red), RF Level / Battery Strength (3 pc)
Peak LED lighting point	AF output level approx. +4 dB
Controls	Audio Level switch, Squelch volume, Headphone volume, Meter function switch
Operating Temperature	0° C / 55° C
Operating Voltage	AC adapter DC 6 - 13 Volts, 9 volts battery
Current Consumption	>60 mA (no signal, all LEDs off)
Receiving Frequency Range	642.375----645.750MHz
Squelch Sensitivity	17 dB μ v \pm 4 dB
T.H.D. (Overall)	1% Max (@AF 1 kHz, RF 56 dB μ v)
Dynamic Range	95 dB (w/IHF-A Filter)
AF Frequency Response	50 Hz - 15 kHz (\pm 3 dB overall)
Audio Output Level	0 dBv \pm 2 dB (Maximum +9 dBv \pm 3 dB @ 3% THD)
Audio Output Impedance	1 k Ohms max. (Unbalanced), 600 Ohms (Balanced)
Headphone Output Impedance	32 Ohms
Battery life	12 hours typical