



243 Jubug-Ri, Yangji-Myeon, Yongin-Si, Gyeonggi-Do, Korea 449-822  
 Tel: +82-31-323-6008 Fax: +82-31-323-6010  
<http://www.ltalab.com>

Dates of Tests: October 18, 2016 ~ February 1, 2017  
 Test Report S/N: LR50011702J  
 Test Site : LTA CO., LTD.

## CERTIFICATION OF COMPLIANCE

FCC ID.  
 IC Application  
 APPLICANT

**CCECDL-3PBRBC**  
**22254-CDL3PBRBC**  
**COMMAX Co., Ltd.**

<b>Equipment Class</b>	<b>:</b>	<b>Digital Transmission System (DTS)</b>
<b>Manufacturing Description</b>	<b>:</b>	<b>DIGITAL DOOR LOCK</b>
<b>Manufacturer</b>	<b>:</b>	<b>COMMAX Co., Ltd.</b>
<b>Model name</b>	<b>:</b>	<b>CDL-3PBRBC</b>
<b>Test Device Serial No.:</b>	<b>:</b>	<b>Identical prototype</b>
<b>Rule Part(s)</b>	<b>:</b>	<b>FCC Part 15.247</b> <b>Subpart C ; ANSI C-63.4-2014 / ANSIC C-63.10-2013</b> <b>RSS-247 and Issue No.2 DATE : 2017</b>
<b>Frequency Range</b>	<b>:</b>	<b>2402 ~ 2480 MHz (Bluetooth)</b>
<b>Max. Output Power</b>	<b>:</b>	<b>Max -2.07 dBm – Conducted (Bluetooth)</b>
<b>Data of issue</b>	<b>:</b>	<b>February 1, 2017</b>

This test report is issued under the authority of:

Yong-Cheol, Wang / Manager

The test was supervised by:

Hee-Cheon, Kwon / Test Engineer

**This test result only responds to the tested sample. It is not allowed to copy this report even partly without the allowance of the test laboratory. The report must not be used by the client to claim product certification, approval, or endorsement by NVLAP, NIST, or any agency of the Federal Government.**



NVLAP LAB Code.: 200723-0

---

## TABLE OF CONTENTS

1. GENERAL INFORMATION	-----	3
2. INFORMATION ABOUT TEST ITEM	-----	4
3. TEST REPORT	-----	5
3.1 SUMMARY OF TESTS	-----	5
3.2 TECHNICAL CHARACTERISTICS TEST	-----	6
3.2.1 6 dB BANDWIDTH&99% Bandwidth	-----	6
3.2.2 PEAK OUTPUT POWER	-----	10
3.2.3 POWER SPECTRAL DENSITY	-----	13
3.2.4 BAND EDGE	-----	16
3.2.5 CONDUCTED SPURIOUS EMISSIONS	-----	19
3.2.6 RADIATED SPURIOUS EMISSIONS	-----	22
<b>APPENDIX</b>		
APPENDIX TEST EQUIPMENT USED FOR TESTS	-----	68

## 1. General information

### 1-1 Test Performed

Company name : LTA Co., Ltd.  
 Address : 243, Jubug-ri, Yangji-Myeon, Youngin-Si, Kyunggi-Do, Korea. 449-822  
 Web site : <http://www.ltalab.com>  
 E-mail : [chahn@ltalab.com](mailto:chahn@ltalab.com)  
 Telephone : +82-31-323-6008  
 Facsimile : +82-31-323-6010

Quality control in the testing laboratory is implemented as per ISO/IEC 17025 which is the “General requirements for the competents of calibration and testing laboratory”.

### 1-2 Accredited agencies

LTA Co., Ltd. is approved to perform EMC testing by the following agencies:

Agency	Country	Accreditation No.	Validity	Reference
NVLAP	U.S.A	200723-0	2017-09-30	ECT accredited Lab.
RRA	KOREA	KR0049	-	EMC accredited Lab.
FCC	U.S.A	610755	2017-04-21	FCC filing
FCC	U.S.A	649054	2017-04-13	FCC CAB
VCCI	JAPAN	R2133(10 m), C2307	2017-06-21	VCCI registration
VCCI	JAPAN	T-2009	2017-12-23	VCCI registration
VCCI	JAPAN	G-563	2018-12-13	VCCI registration
IC	CANADA	5799A-1	2019-11-07	IC filing
KOLAS	KOREA	NO.551	2017-01-08	KOLAS accredited Lab.

## 2. Information about test item

### 2-1 Client & Manufacturer

Company name : COMMAX Co., Ltd.  
 Address : 513-11, Sangdaewon-Dong, Sungnam-si, Gyeonggi-do, South Korea  
 Tel / Fax : TEL No : +82-31-739-3682 / FAX No : +82-31-739-3649

### 2-2 Equipment Under Test (EUT)

Model name : CDL-3PBRBC  
 Serial number : Identical prototype  
 Date of receipt : October 18, 2016  
 EUT condition : Pre-production, not damaged  
 Antenna type : Pattern Antenna: -2.73 dBi (Bluetooth)  
 Frequency Range : 2402 ~ 2480 MHz (Bluetooth)  
 RF output power : **Max -2.07 dBm – Conducted (Bluetooth)**  
 Number of channels : 40 (Bluetooth)  
 Type of Modulation : GFSK (Bluetooth)  
 Power Source : 6.0 Vdc  
 Firmware Version : V 1.0.0

### 2-3 Tested frequency

	LOW	MID	HIGH
Frequency (MHz) (Bluetooth module2)	2402	2442	2480

### 2-4 Ancillary Equipment

Equipment	Model No.	Serial No.	Manufacturer
NOTEBOOK	CR720	MS-1736	MSI

### 3. Test Report

#### 3.1 Summary of tests

FCC Part Section(s)	Parameter	Limit	Test Condition	Status (note 1)
15.247(a)	6 dB Bandwidth & 99 % Bandwidth	> 500 kHz	Conducted	C
15.247(b)	Transmitter Peak Output Power	< 1 Watt		C
15.247(d)	Transmitter Power Spectral Density	< 8 dBm @ 3 kHz		C
15.247(d)	Band Edge	> 20 dBc		C
15.209	Field Strength of Harmonics	Emission	Radiated	C
15.207	AC Conducted Emissions	Emissions	Conducted	NA
15.203	Antenna requirement	-	-	C

Note 1: C=Complies NC=Not Complies NT=Not Tested NA=Not Applicable

Note 2: The data in this test report are traceable to the national or international standards.

#### → Antenna Requirement

The COMMAX Co., Ltd. FCC ID: CCECDL-3PBRBC unit complies with the requirement of §15.203.  
The antenna type is Pattern Antenna.

The sample was tested according to the following specification:

\*FCC Parts 15.247; ANSI C-63.4-2014;ANSI C-63.10-2013

\*FCC KDB Publication No. 558074 D01 v03r05

\*FCC TCB Workshop 2012, April

\*RSS-247 and Issue No.2 Date:2017

## 3.2 Technical Characteristics Test

### 3.2.1 6 dB Bandwidth & 99 % Bandwidth

#### Procedure:

The bandwidth at 6 dB below the highest in-band spectral density was measured with a spectrum analyzer connected to the antenna terminal, while EUT is operating in transmission mode at the appropriate frequencies.

After the trace being stable, Use the marker-to-peak function to set the marker to the peak of the emission. Use the marker-delta function to measure 6 dB down one side of the emission. Reset the marker-delta function, and move the marker to the other side of the emission, until it is ( as close as possible to ) even with the reference marker level. The marker-delta reading at this point is the 6 dB bandwidth of the emission.

#### The spectrum analyzer is set to:

Center frequency = the highest, middle and the lowest channels

RBW = 100 kHz

Span = 5 MHz

VBW = 100 kHz (VBW  $\geq$  RBW)

Sweep = auto

Trace = max hold

Detector function = peak

#### Measurement Data : **Complies**

Frequency (MHz)	Test Results	
	Measured Bandwidth (MHz)	99 % Bandwidth (MHz)
Bluetooth		
2402	0.767	1.17
2442	0.767	1.17
2480	0.760	1.30

- See next pages for actual measured spectrum plots.

#### Minimum Standard:

6 dB Bandwidth > 500 kHz

#### Measurement Setup

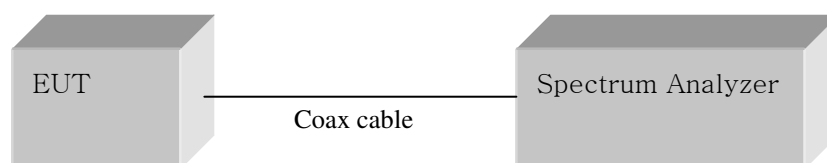
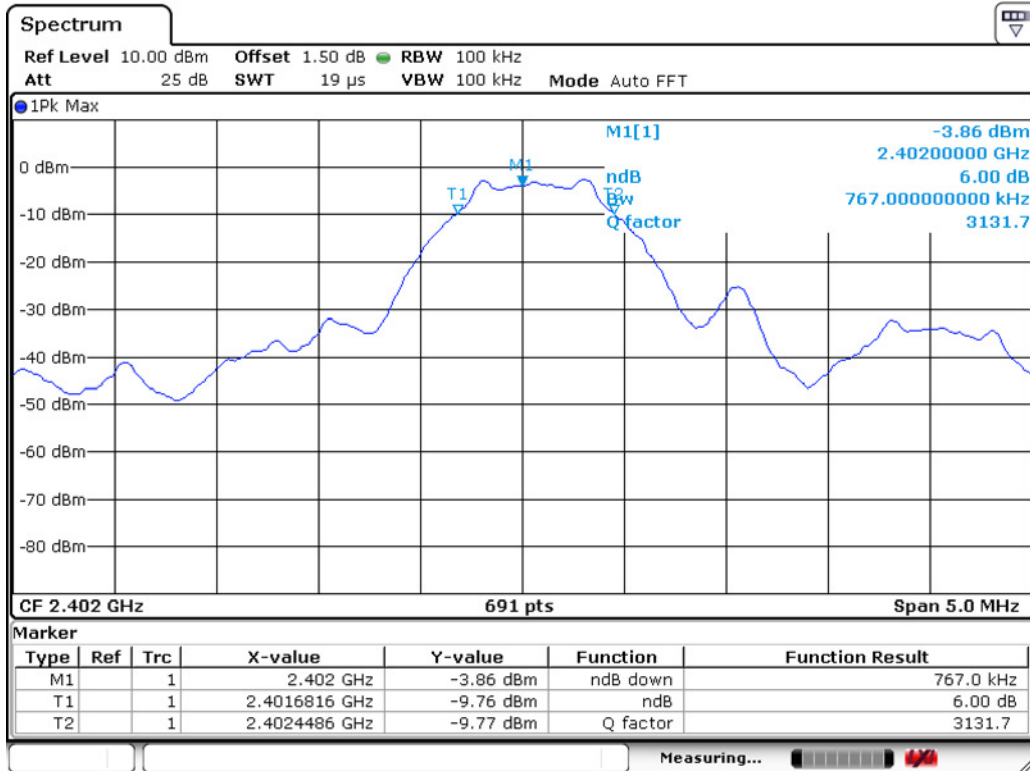
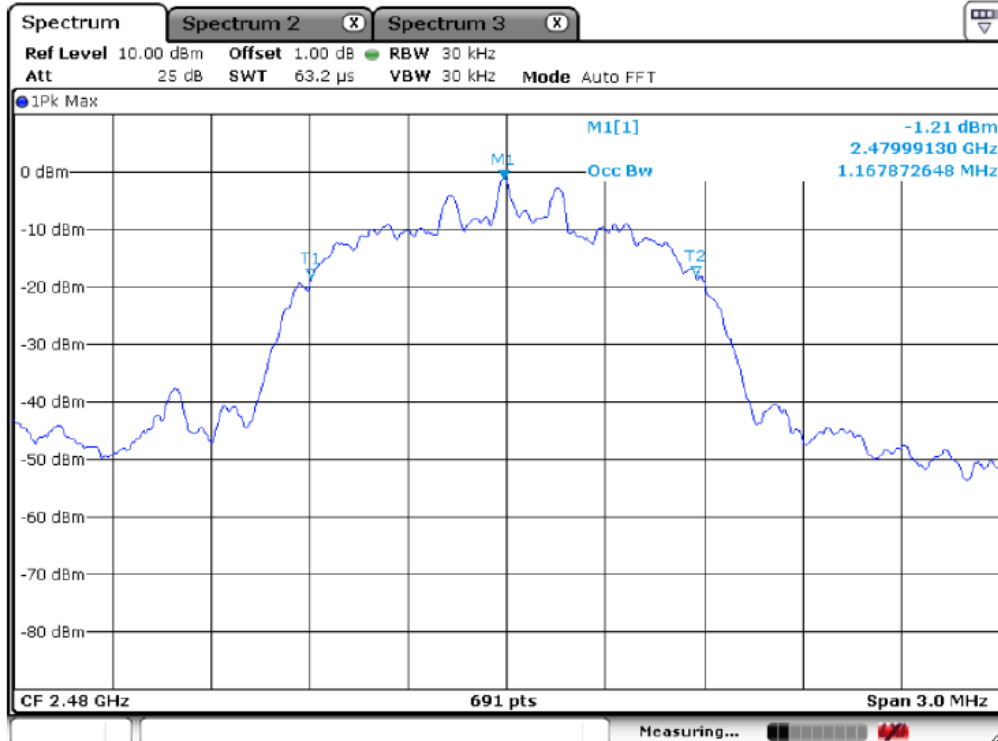

Figure 1: Measurement setup for the carrier frequency separation

### Low Channel (Bluetooth)



### 99% Bandwidth



### Middle Channel (Bluetooth)

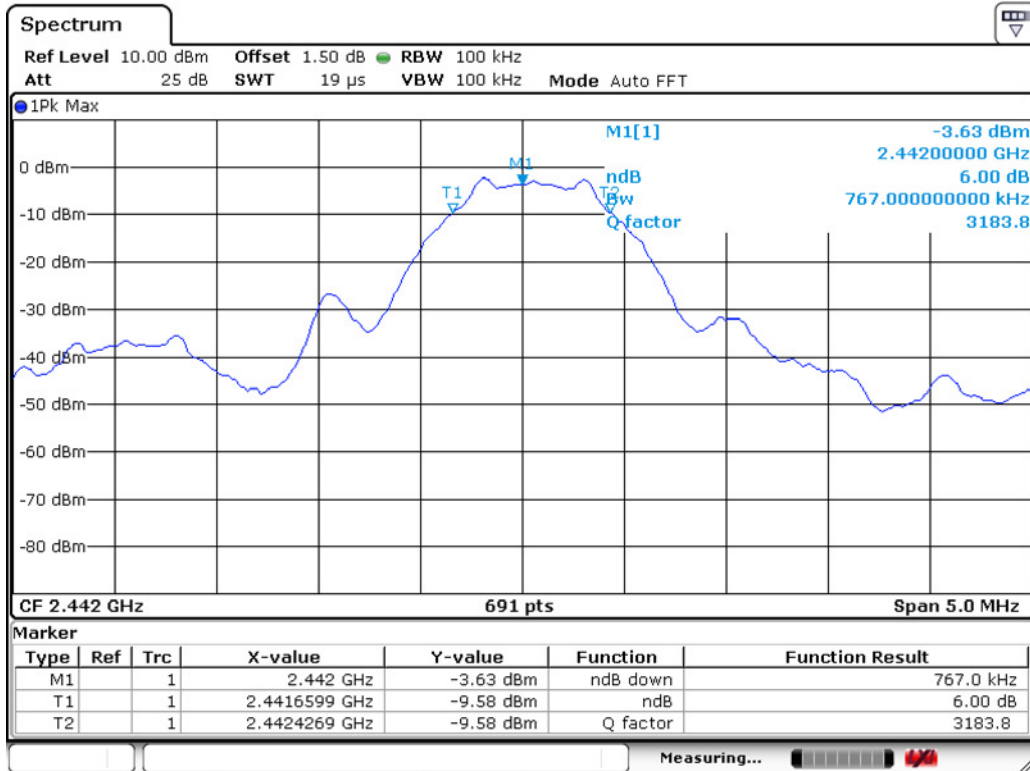

### 99% Bandwidth

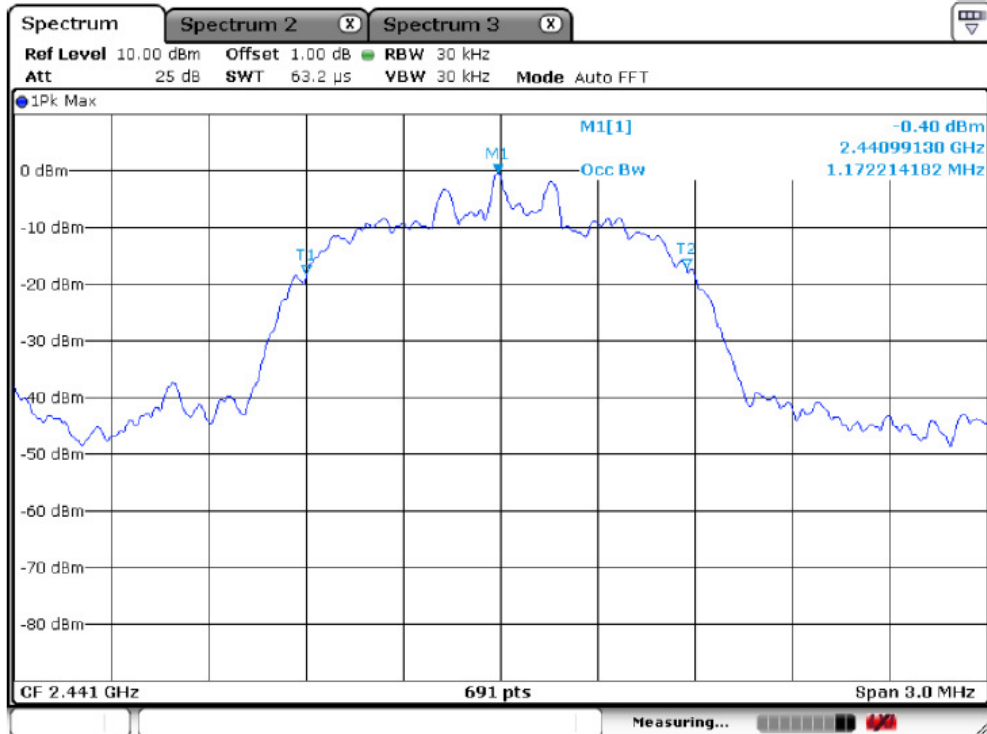



## High Channel (Bluetooth)

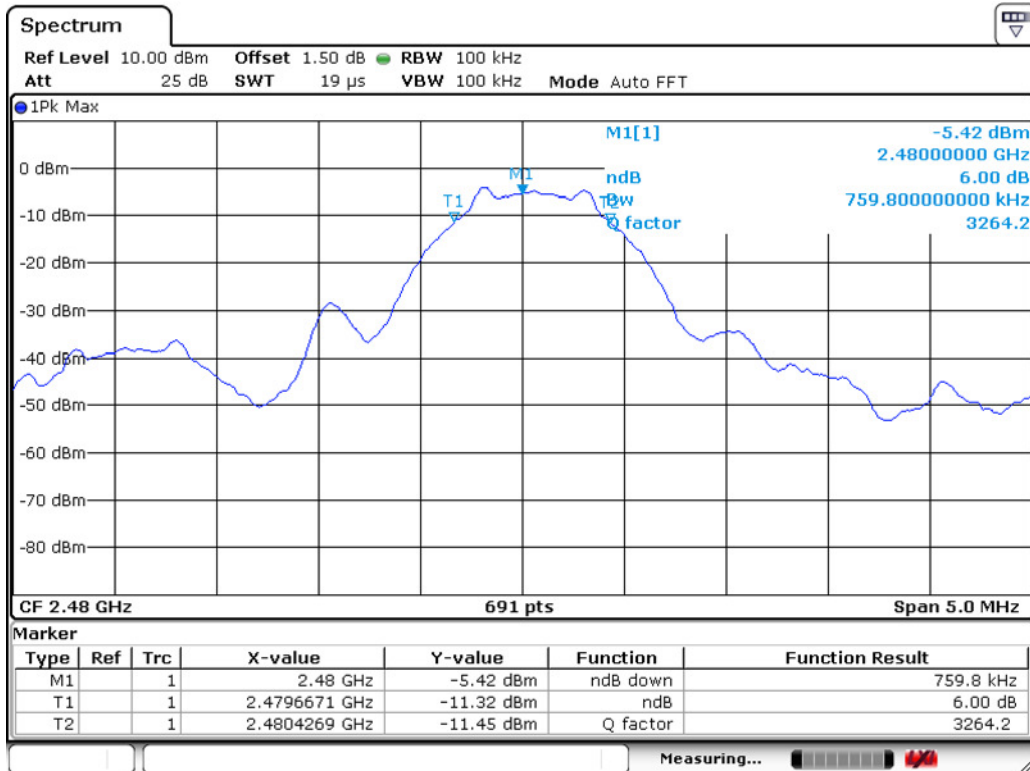

## 99% Bandwidth

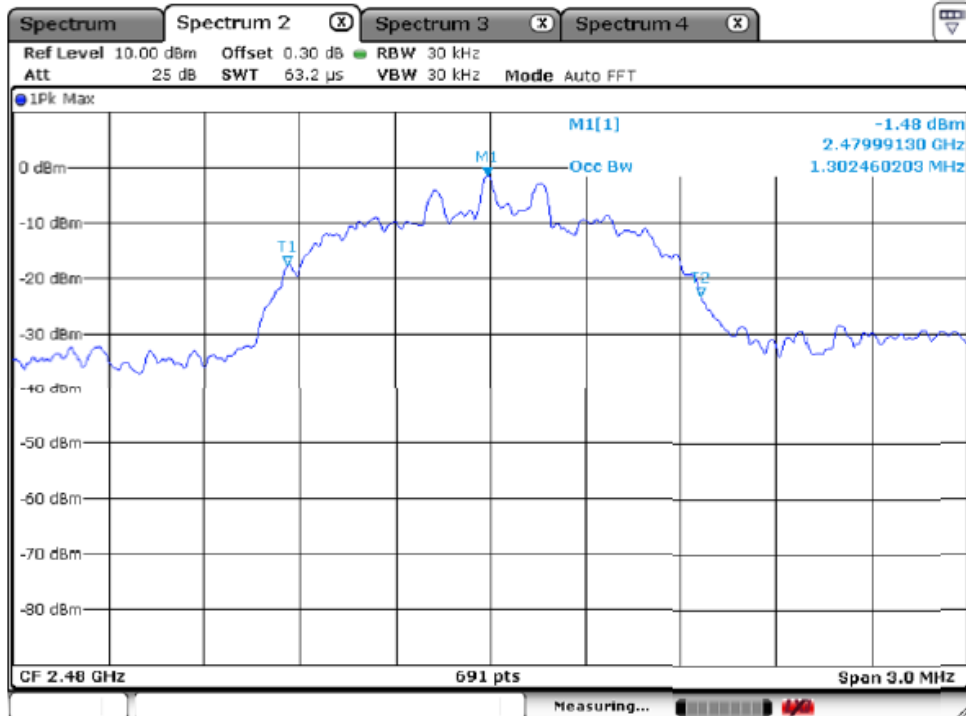

### 3.2.2 Peak Output Power Measurement

#### Procedure:

The maximum peak output power was measured with the spectrum analyzer connected to the antenna output of the EUT. The spectrum analyzer's internal channel power integration function is used to integrate the power over a bandwidth greater than or equal to the 99 % bandwidth. The EUT was operating in transmit mode at the appropriate center frequency.

The spectrum analyzer is set to:

Center frequency = the highest, middle and the lowest channels

RBW = 1 MHz

Span = auto

VBW = 1 MHz (VBW  $\geq$  RBW)

Sweep = auto

Detector function = peak

#### Measurement Data : **Complies**

Frequency (MHz)	Test Results		
	dBm	mW	Result
Bluetooth			
2402	-2.13	0.61	Complies
2442	-2.07	0.62	Complies
2480	-3.94	0.40	Complies

- See next pages for actual measured spectrum plots.

#### Minimum Standard:

Peak output power	< 1 W
-------------------	-------

#### Measurement Setup

Same as the Chapter 3.2.1 (Figure 1)

### Low Channel (Bluetooth)

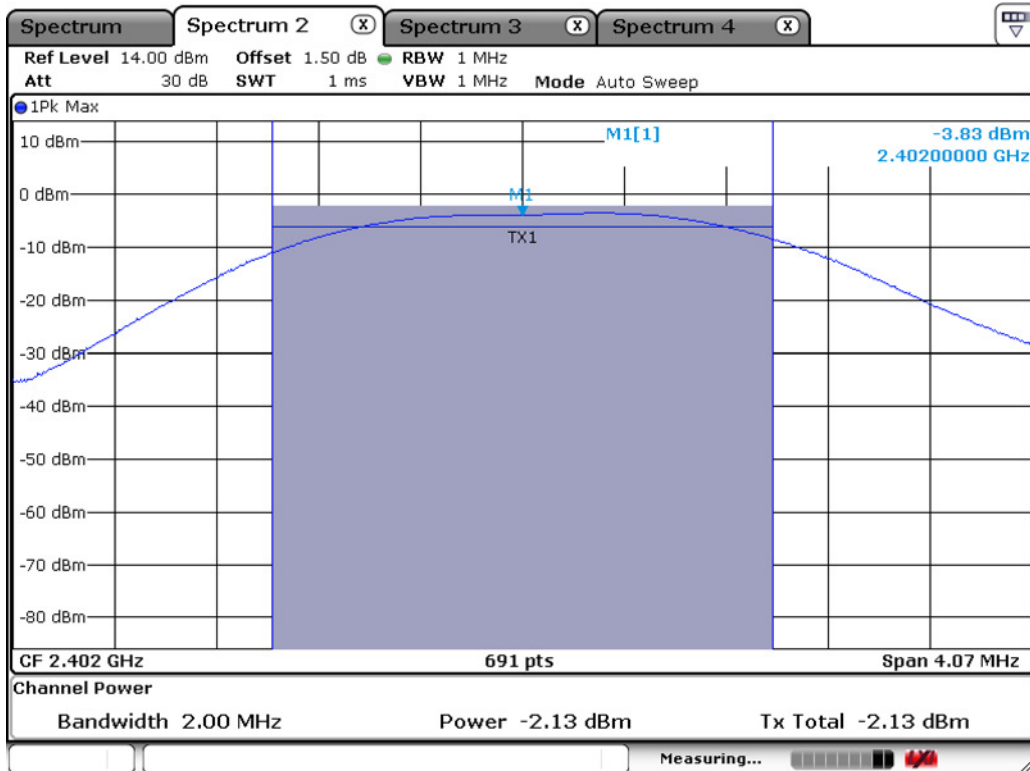

### Middle Channel (Bluetooth)

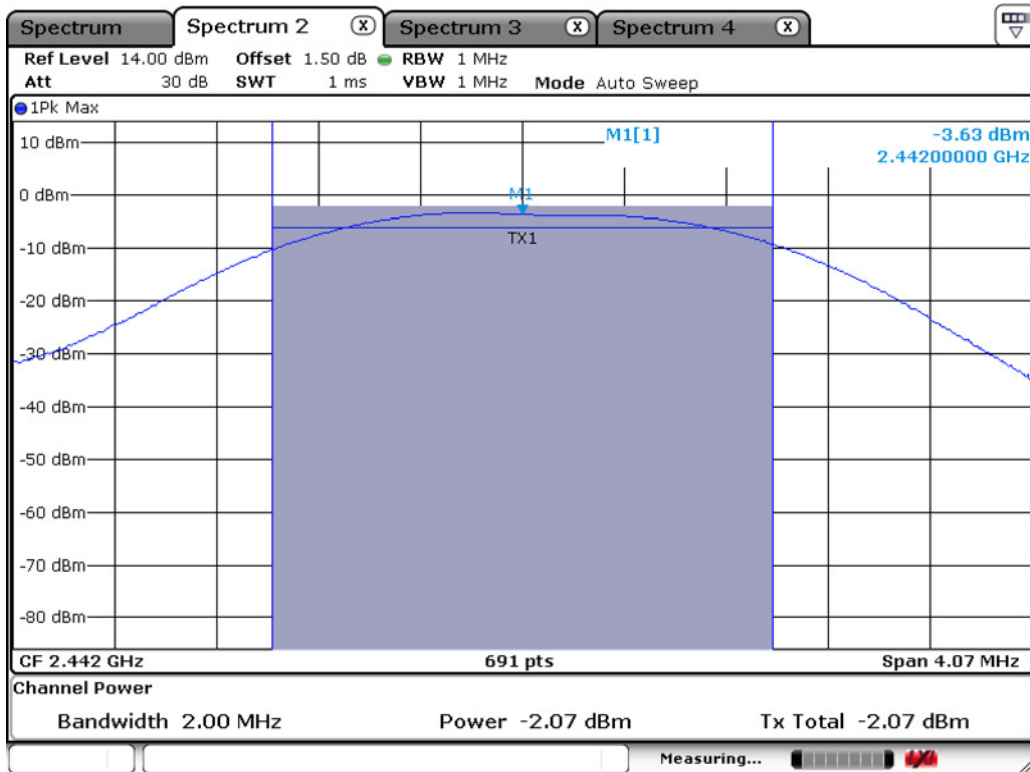

## High Channel (Bluetooth)

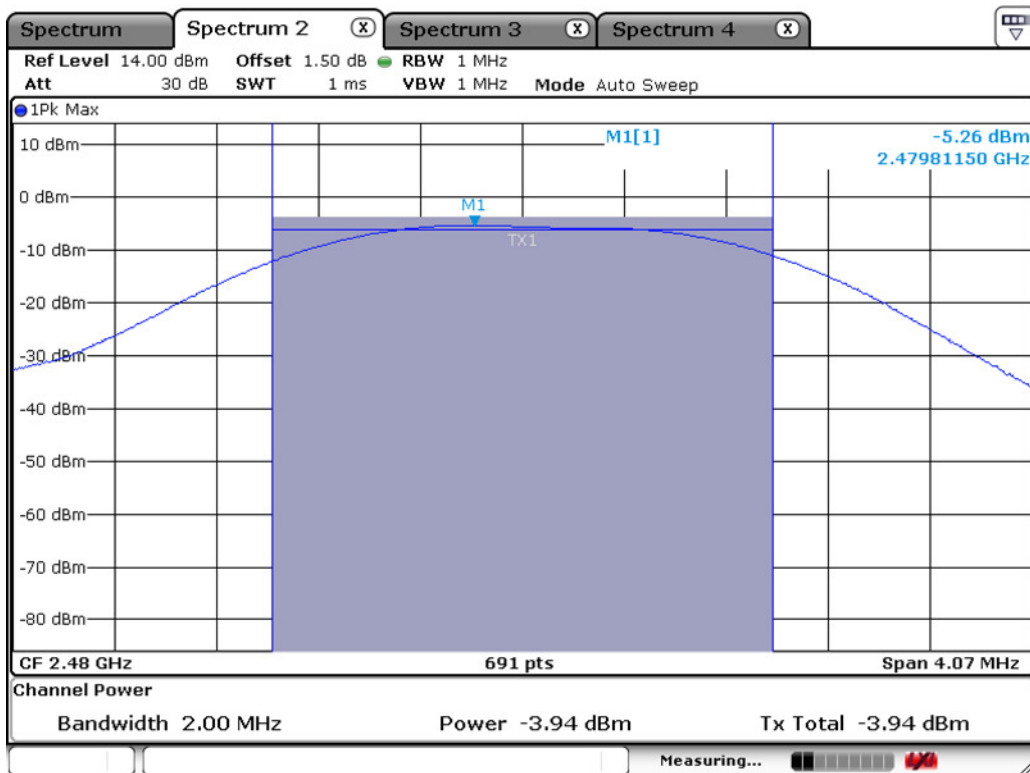

### 3.2.3 Power Spectral Density

#### Procedure:

The peak power density is measured with a spectrum analyzer connected to the antenna terminal while the EUT is operating in transmission mode at the appropriate frequencies.

The spectrum analyzer is set to:

RBW = 3 kHz

Span = 300 kHz

VBW = 3 kHz

Sweep = auto

Detector function = peak

Trace = max hold

#### Measurement Data : **Complies**

Frequency (MHz)	Test Results	
	dBm / 3 kHz	Result
Bluetooth		
2402	-13.87	Complies
2442	-14.10	Complies
2480	-15.69	Complies

- See next pages for actual measured spectrum plots.

#### Minimum Standard:

Power Spectral Density	< 8 dBm @ 3 kHz BW
------------------------	--------------------

#### Measurement Setup

Same as the Chapter 3.2.1 (Figure 1)

## Power Density Measurement Low Channel (Bluetooth)

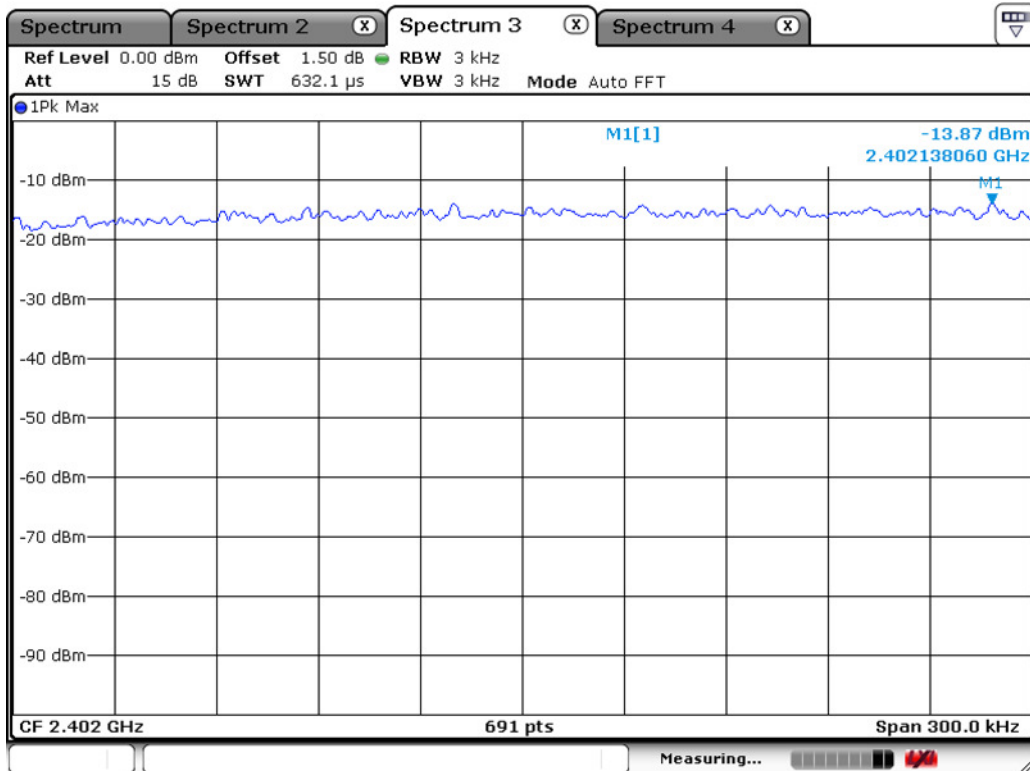

## Middle Channel (Bluetooth)

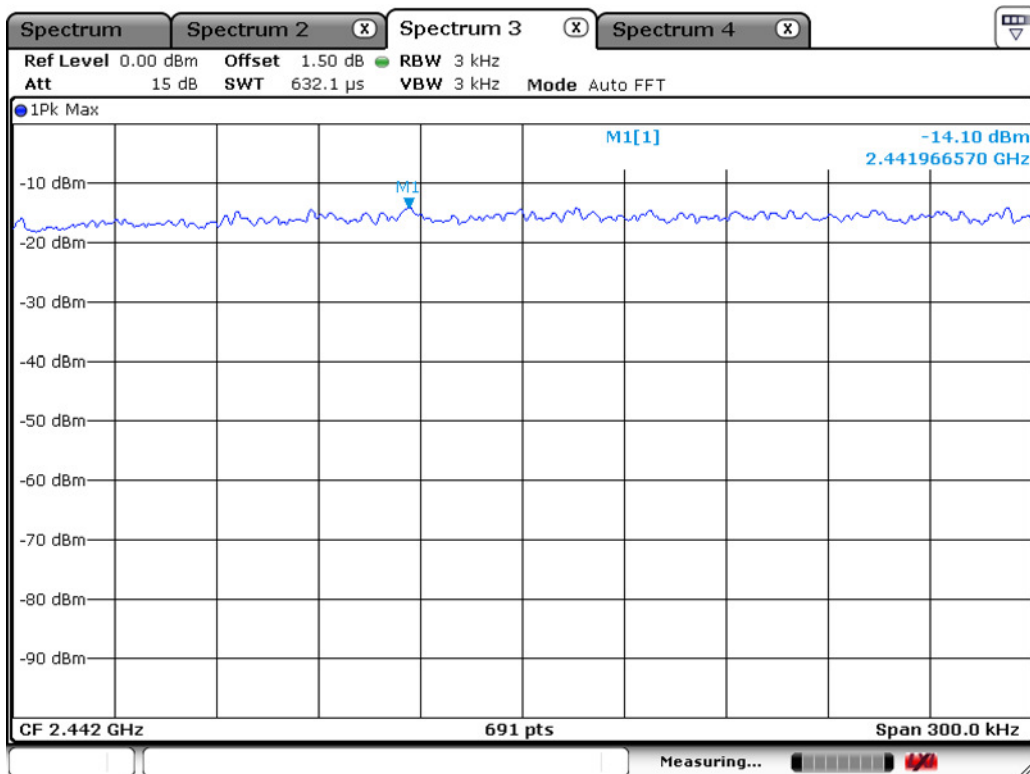

### High Channel (Bluetooth)

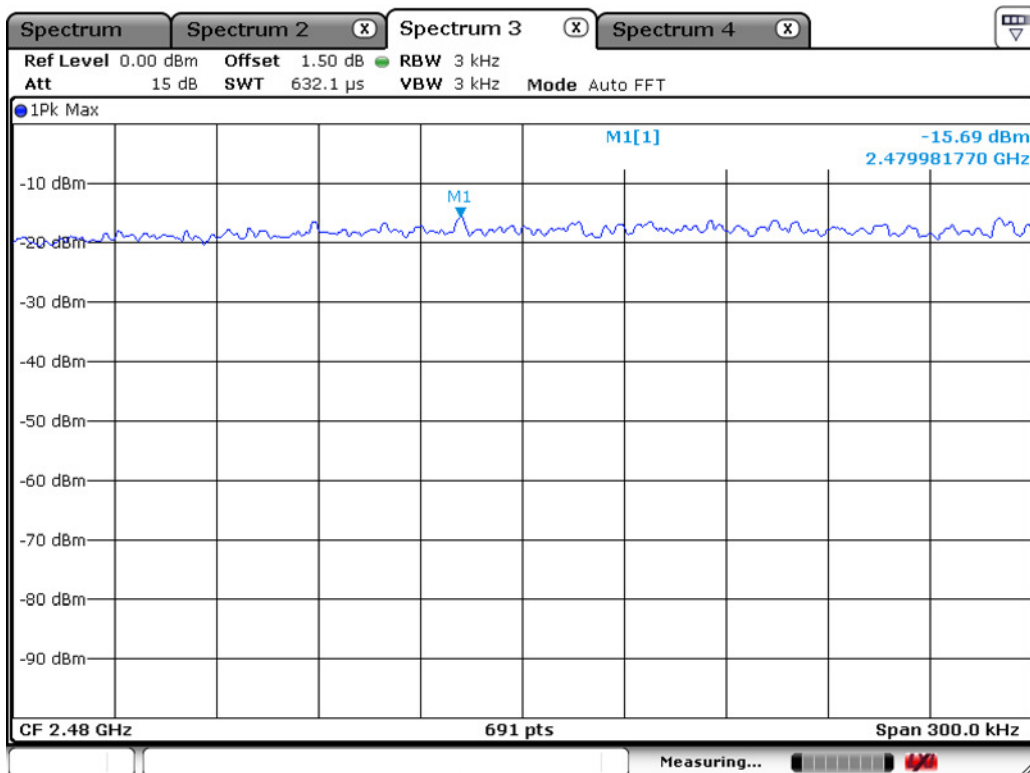

### 3.2.4 Band Edge

#### Procedure:

The bandwidth at 20 dB down from the highest inband spectral density is measured with a spectrum analyzer connected to the antenna terminal, while EUT is operating in transmission mode at the appropriate frequencies.

After the trace being stable, Use the marker-to-peak function to measure 20 dB down both sides of the intentional emission.

The spectrum analyzer is set to:

Center frequency = the highest, middle and the lowest channels

RBW = 100 kHz

VBW = 100 kHz

Span = 40 MHz

Detector function = peak

Trace = max hold

Sweep = auto

Radiated emissions which fall in the restricted bands, as defined in 15.205(a), must also comply with the radiated emission limits specified in 15.209(a)

The spectrum analyzer is set to:

Center frequency = the highest, the lowest channels

PEAK:

RBW = VBW = 1 MHz, Sweep=Auto

Average:

RBW = 1 MHz, VBW=10 Hz, Sweep=Auto

Measurement Distance:

3 m

Polarization:

Horizontal / Vertical

#### Measurement Data: Complies

- All conducted emission in any 100 kHz bandwidth outside of the spread spectrum band was at least 20 dB lower than the highest inband spectral density. Therefore the applying equipment meets the requirement.
- See next pages for actual measured spectrum plots.

<b>Minimum Standard:</b>	> 20 dBc
--------------------------	----------



## Band edge Lower edge (Bluetooth)

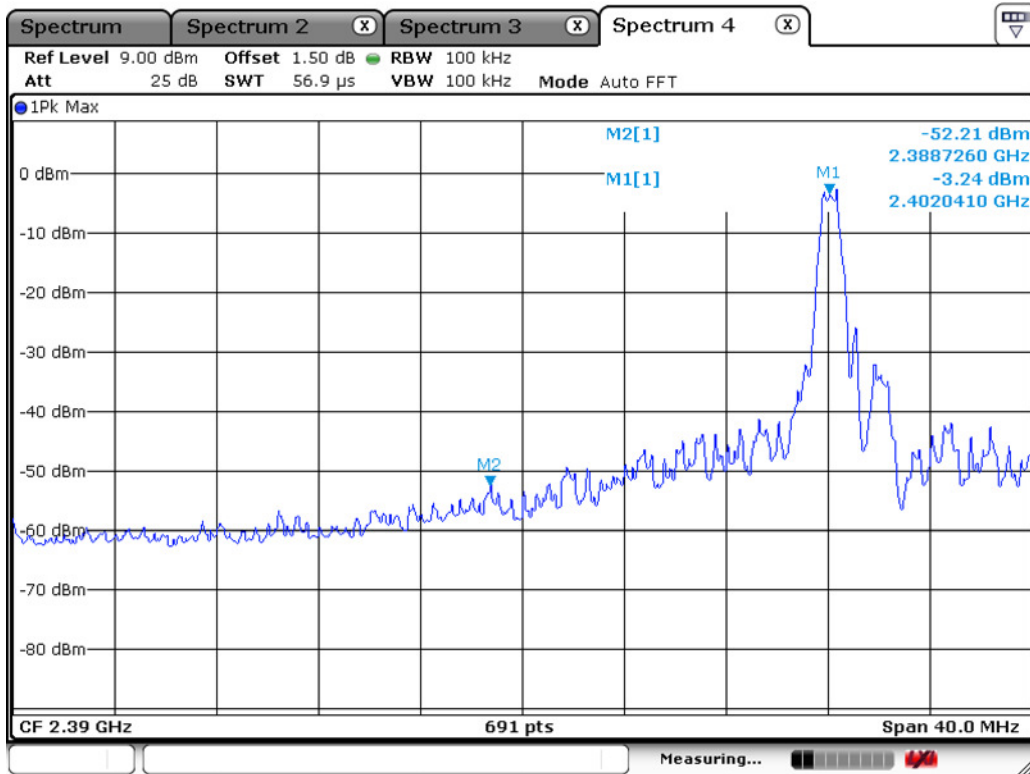

## Upper edge (Bluetooth)

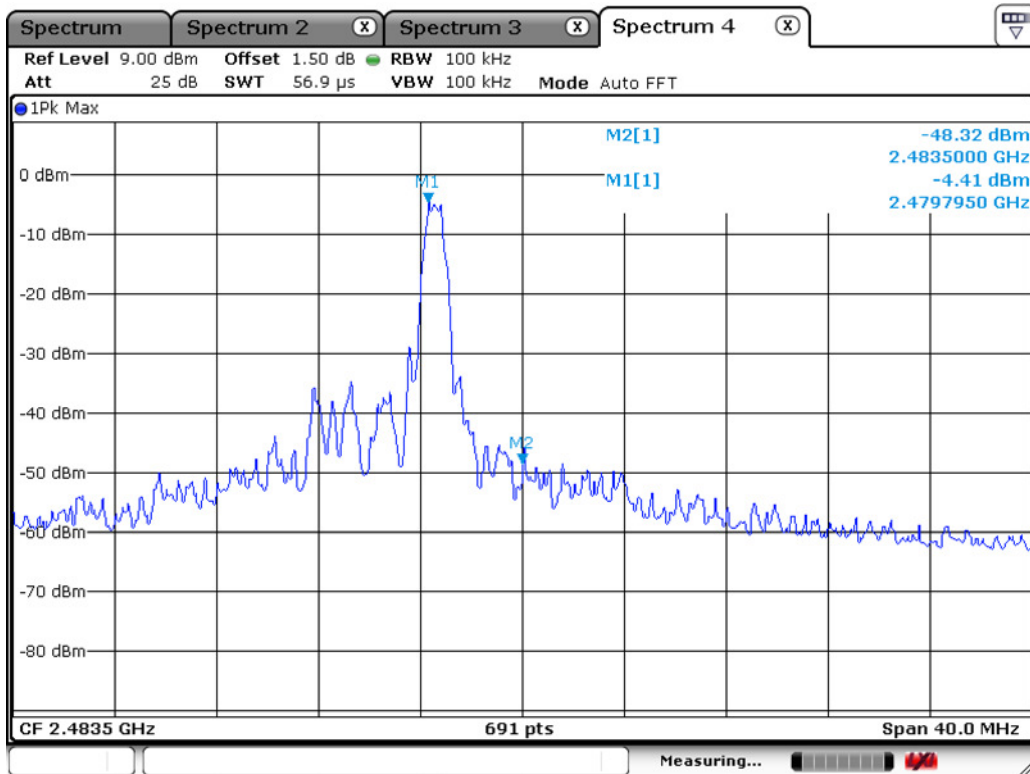

**Radiated Band-edges in the restricted band 2310-2390 MHz measurement\_ Bluetooth**

Frequency [MHz]	Reading [dBuV/ m]		Pol.	Correction Factor		Limits [dBuV/ m]		Result [dBuV/ m]		Margin [dB]	
	AV / Peak			Antenna	Amp. Gain + Cable Loss	AV / Peak		AV / Peak		AV / Peak	
2390.0	27.1	35.3	H	27.9	22.9	54.0	74.0	32.1	40.3	21.9	33.7

**Radiated Band-edges in the restricted band 2483.5-2500 MHz measurement\_ Bluetooth**

Frequency [MHz]	Reading [dBuV/ m]		Pol.	Correction Factor		Limits [dBuV/ m]		Result [dBuV/ m]		Margin [dB]	
	AV / Peak			Antenna	Amp. Gain + Cable Loss	AV / Peak		AV / Peak		AV / Peak	
2483.5	26.7	34.8	H	27.9	22.9	54.0	74.0	31.7	39.8	22.3	34.2

**Note : This EUT was tested in 3 orthogonal positions and the worst-case data was presented**

### 3.2.5 Conducted Spurious Emissions

#### Procedure:

The test follows KDB558074. The conducted spurious emissions were measured with a spectrum analyzer connected to the antenna terminal, while EUT had its hopping function disabled at the highest, middle and the lowest available channels..

After the trace being stable, set the marker on the peak of any spurious emission recorded.

#### The spectrum analyzer is set to:

Span = wide enough to capture the peak level of the in-band emission and all spurious emissions

RBW = 100 kHz

Sweep = auto

VBW = 100 kHz

Detector function = peak

Trace = max hold

#### Measurement Data: **Complies**

- All conducted emission in any 100 kHz bandwidth outside of the spread spectrum band was at least 20 dB lower than the highest inband spectral density. Therefore the applying equipment meets the requirement.
- See next pages for actual measured spectrum plots.

<b>Minimum Standard:</b>	> 20 dBc
--------------------------	----------

#### Measurement Setup

Same as the Chapter 3.2.1 (Figure 1)

**Unwanted Emission – Low Channel (Bluetooth)**

**Frequency Range = 30 MHz ~ 26.5 GHz**

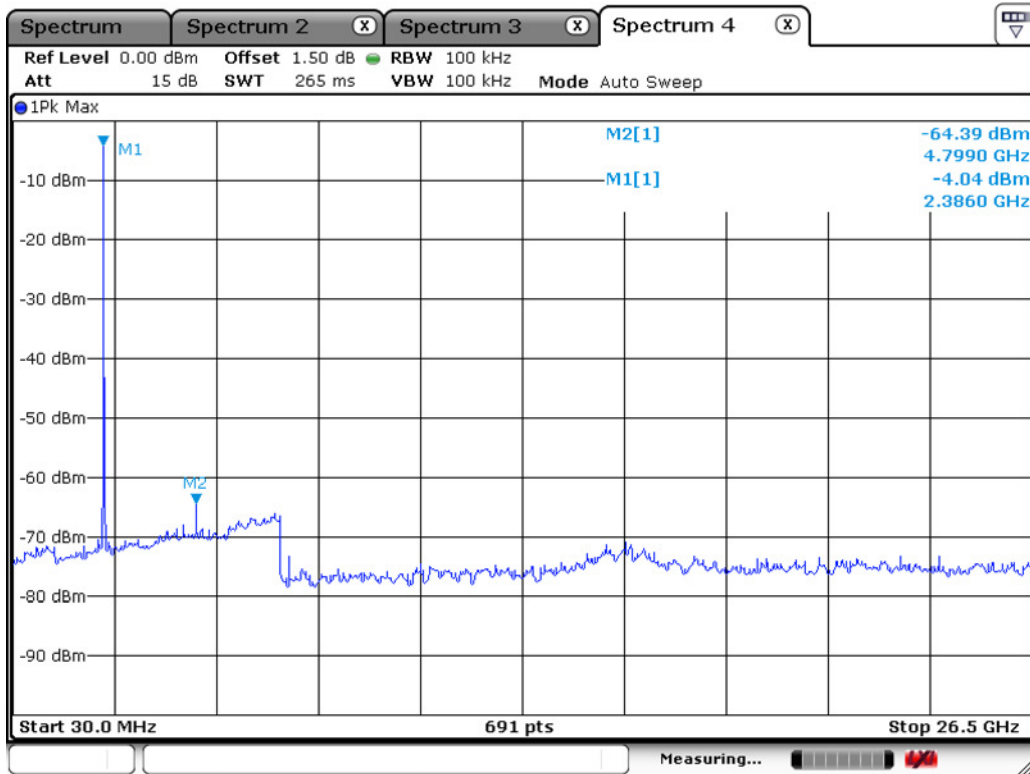

**Unwanted Emission – Middle Channel (Bluetooth)**

**Frequency Range = 30 MHz ~ 26.5 GHz**

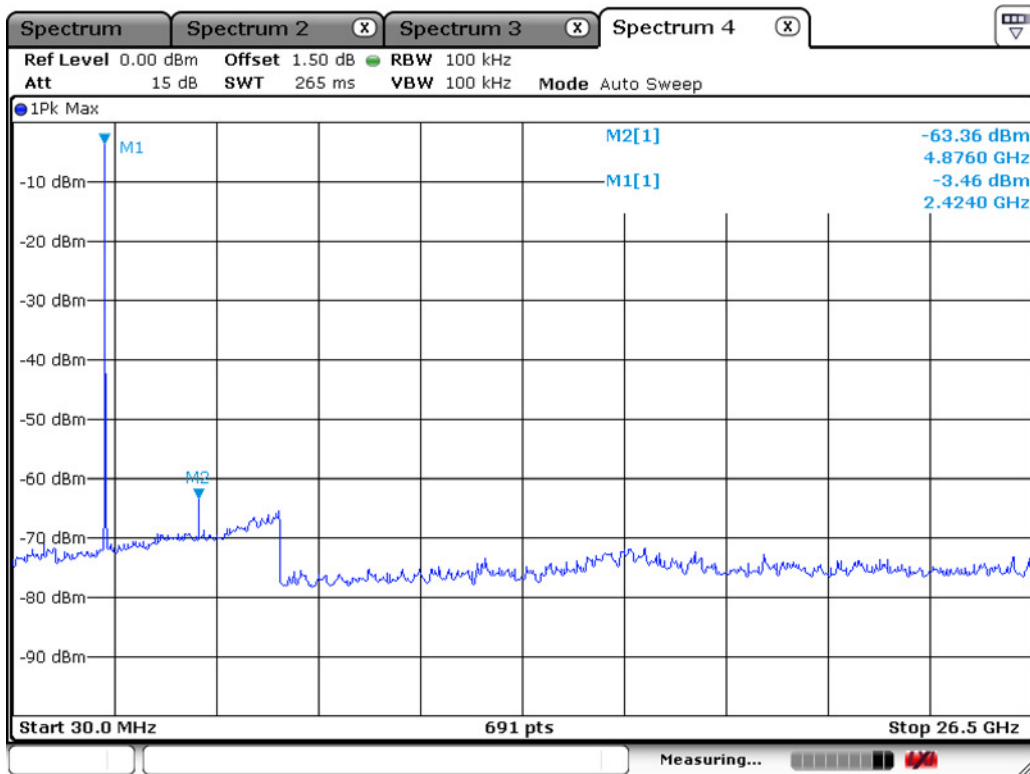

**Unwanted Emission – High Channel (Bluetooth)**

**Frequency Range = 30 MHz ~ 26.5 GHz**

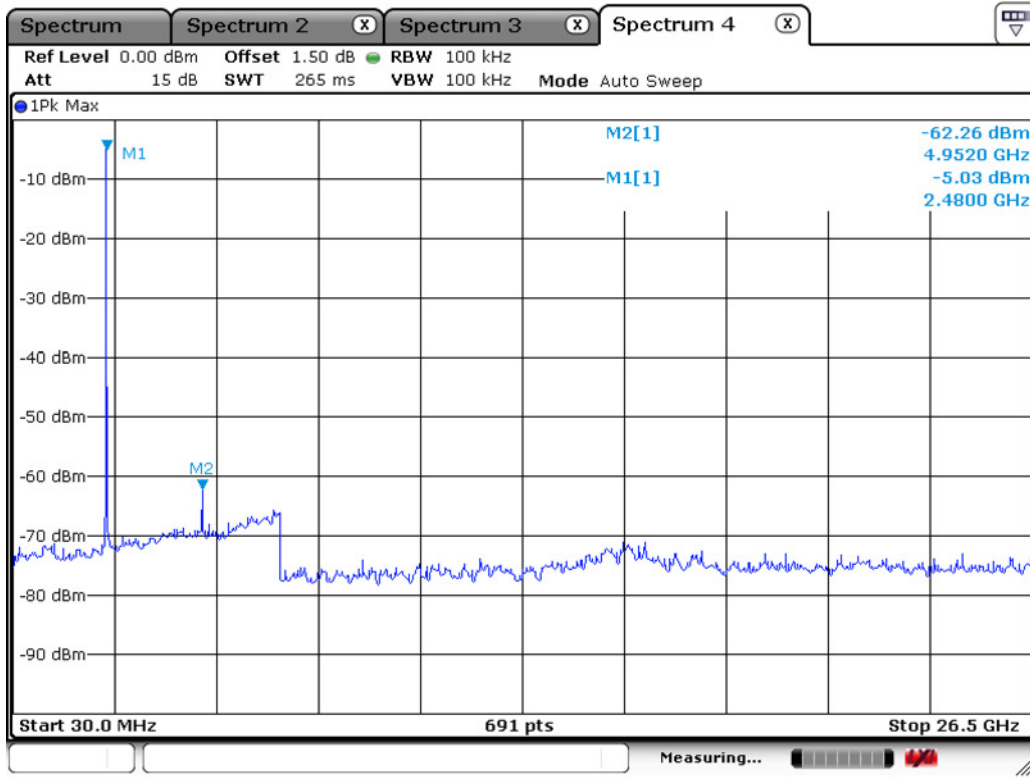

### 3.2.6 Radiated Spurious Emissions

#### Procedure:

The EUT was placed on a 0.8m high wooden table inside a shielded enclosure. An antenna was placed near the EUT and measurements of frequencies and amplitudes of field strengths were recorded for reference during final measurements. For final radiated testing, measurements were performed in OATS. Measurements were performed with the EUT oriented in 3 orthogonal axis and rotated 360 degrees to determine worst-case orientation for maximum emissions.

#### The spectrum analyzer is set to:

Center frequency = the worst channel

Frequency Range = 9 kHz ~ 10<sup>th</sup> harmonic.

RBW = 100 kHz ( 30 MHz ~ 1 GHz)

= 1 MHz ( 1 GHz ~ 10<sup>th</sup> harmonic )

Span = 100 MHz

Trace = max hold

VBW  $\geq$  RBW

Detector function = peak

Sweep = auto

below 30 MHz

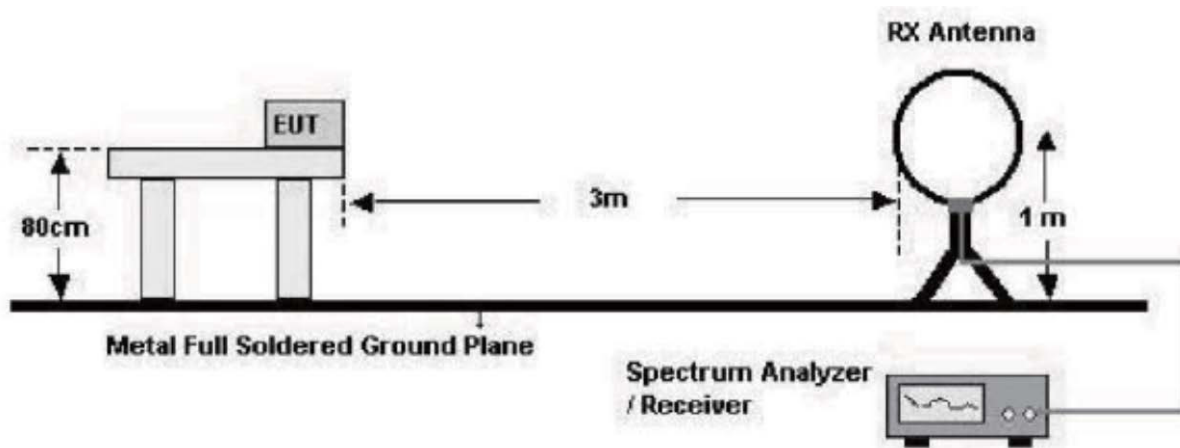

below 1 GHz (30 MHz to 1 GHz)

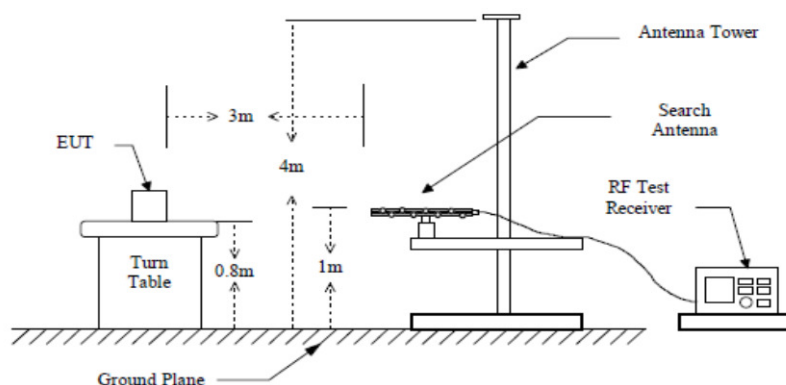

above 1 GHz

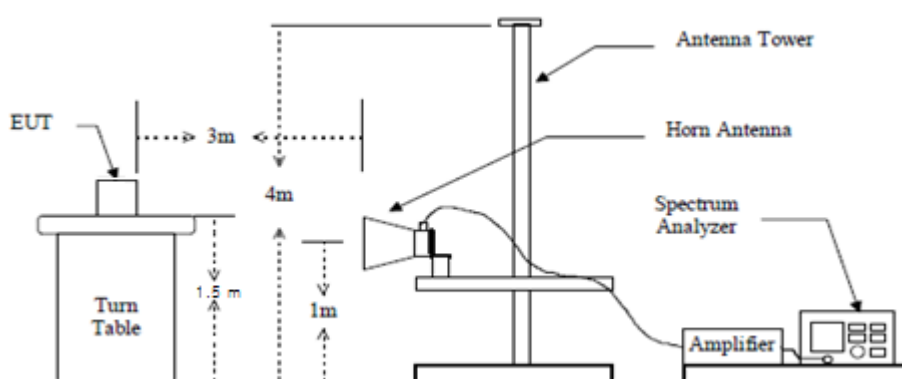

**Measurement Data: Complies**

- See next pages for actual measured data.
- No other emissions were detected at a level greater than 20 dB below limit include from 9 kHz to 30 MHz.

**Minimum Standard: FCC Part 15.209(a)**

Frequency (MHz)	Limit (uV/m) @ 3 m
0.009 ~ 0.490	2400/F(kHz) (@ 300 m)
0.490 ~ 1.705	24000/F(kHz) (@ 30 m)
1.705 ~ 30	30(@ 30 m)
30 ~ 88	100 **
88 ~ 216	150 **
216 ~ 960	200 **
Above 960	500

\*\* Except as provided in 15.209(g), fundamental emissions from intentional radiators operating under this Section shall not be located in the frequency bands 54-72 MHz, 76-88 MHz, 174-216 MHz or 470-806 MHz. However, operation within these frequency bands is permitted under other sections of this Part, e.g. 15.231 and 15.241.

**Measurement Data : (Above 1 GHz) – Bluetooth**

Frequency [MHz]	Reading [dBuV/ m]		Pol.	Correction Factor		Limits [dBuV/ m]		Result [dBuV/ m]		Margin [dB]	
	AV / Peak			Antenna	Amp.Gain+ Cable	AV/ Peak		AV/ Peak		AV / Peak	
7462.7	15.45	25.45	H	37.15	4.20	54.0	74.0	48.40	58.40	5.60	15.60
7511.5	15.51	25.51	H	37.18	3.64	54.0	74.0	49.05	59.05	4.95	14.95
7614.1	17.29	27.29	H	37.04	4.68	54.0	74.0	49.65	59.65	4.35	14.35

- No other emissions were detected at a level greater than 20 dB below limit.

**Measurement Data : (9 kHz – 30 MHz)**

Frequency [MHz]	Reading [dBuV/ m]		Pol.	Correction Factor		Limits [dBuV/ m]		Result [dBuV/ m]		Margin [dB]	
	AV / Peak			Antenna	Amp.Gain+ Cable	AV / Peak		AV / Peak		AV / Peak	
-	-	-	-	-	-	-	-	-	-	-	-
No emissions were detected at a level greater than 20 dB below limit.											
-	-	-	-	-	-	-	-	-	-	-	-
-	-	-	-	-	-	-	-	-	-	-	-

\*No emissions were detected at a level greater than 20 dB below limit.



**Radiated Emissions (Below 1 GHz) – 2.4GHz Bluetooth mode (LOW)**



4, Songjuro236Beon-gil, Yangji-myeon,  
Cheoin-gu, Youngin-si, Gyeonggi-do,  
449-822 Korea  
Tel :+82-31-3236008,9  
Fax:+82-31-3236010

EUT/Model No. : CDL-3PER

TEST MODE: Bluetooth LOW mode

Temp Humi : 0 / 50

Tested by: BANG Y H

Data: 294

Date: 2016-12-28

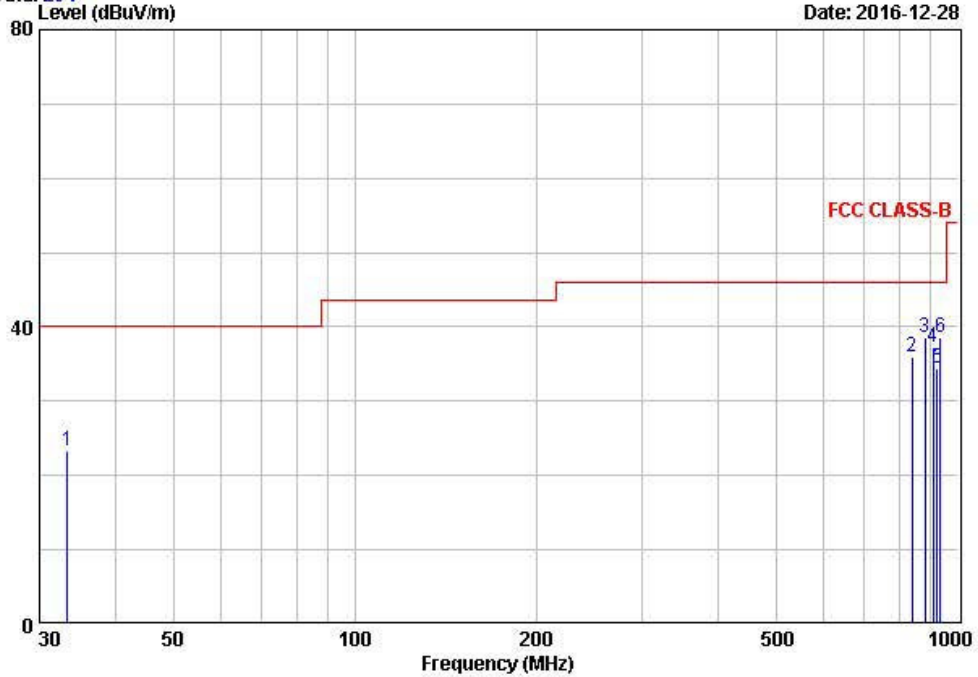

	Freq	Reading	C.F	Result	Limit	Margin	Height	Angle	Polarity
	MHz	dBuV	dB	dBuV/m	dBuV/m	dB	cm	deg	
1	33.40	42.10	-18.83	23.27	40.00	16.73	100	124	VERTICAL
2	839.40	36.10	-0.14	35.96	46.00	10.04	344	189	HORIZONTAL
3	881.65	37.90	0.70	38.60	46.00	7.40	314	11	HORIZONTAL
4	910.41	35.90	1.28	37.18	46.00	8.82	300	84	HORIZONTAL
5	924.50	32.80	1.55	34.35	46.00	11.65	199	65	HORIZONTAL
6	935.10	36.80	1.76	38.56	46.00	7.44	317	84	HORIZONTAL

Remarks: C.F (Correction Factor) = Antenna factor + Cable loss - Preamp gain

**Radiated Emissions (Below 1 GHz) – 2.4GHz Bluetooth mode (MID)**



4, Songjuro236Beon-gil, Yangji-myeon,  
Cheoin-gu, Youngin-si, Gyeonggi-do,  
449-822 Korea  
Tel :+82-31-3236008,9  
Fax:+82-31-3236010

EUT/Model No.: CDL-3PER

TEST MODE: Bluetooth mid mode

Temp Humi : 0 / 50

Tested by: BANG Y H

Data: 295

Level (dBuV/m)

Date: 2016-12-28

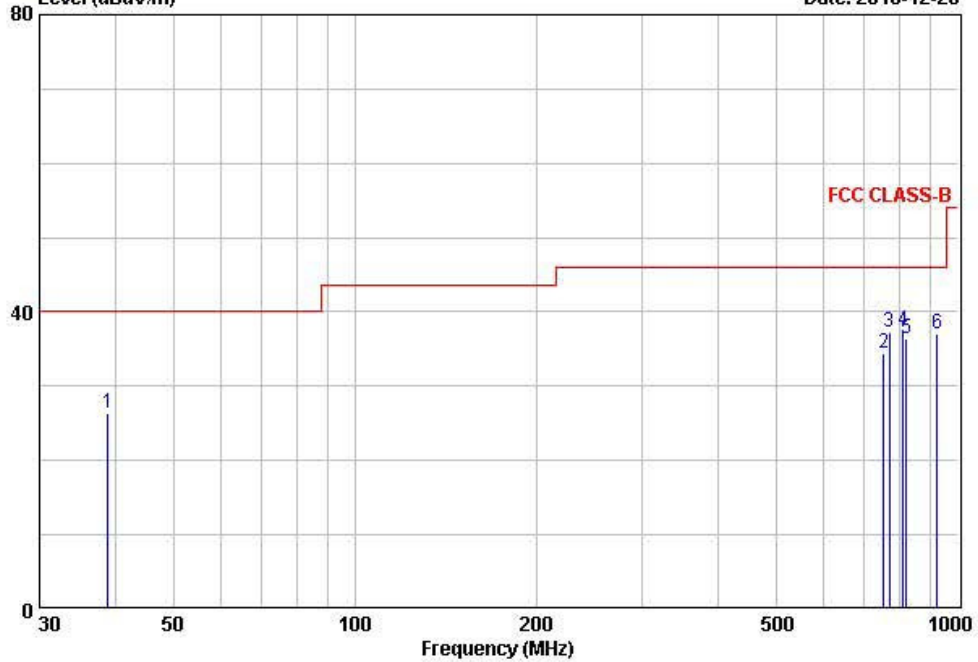

	Freq	Reading	C.F	Result	Limit	Margin	Height	Angle	Polarity
	MHz	dBuV	dB	dBuV/m	QP	dB	cm	deg	
1	38.90	44.50	-18.23	26.27	40.00	13.73	100	188	VERTICAL
2	754.10	36.10	-1.67	34.43	46.00	11.57	318	54	HORIZONTAL
3	768.90	38.60	-1.41	37.19	46.00	8.81	311	184	HORIZONTAL
4	810.40	38.10	-0.69	37.41	46.00	8.59	304	8	HORIZONTAL
5	821.40	36.80	-0.48	36.32	46.00	9.68	400	84	HORIZONTAL
6	924.10	35.60	1.55	37.15	46.00	8.85	311	77	HORIZONTAL

Remarks: C.F (Correction Factor) = Antenna factor + Cable loss - Preamp gain

**Radiated Emissions(Below 1 GHz) – 2.4GHz Bluetooth mode (HIGH)**



4, Songjuro236Beon-gil, Yangji-myeon,  
Cheoin-gu, Youngin-si, Gyeonggi-do,  
449-822 Korea  
Tel :+82-31-3236008,9  
Fax:+82-31-3236010

EUT/Model No.: CDL-3PER

TEST MODE: Bluetooth mid mode

Temp Humi : 0 / 50

Tested by: BANG Y H

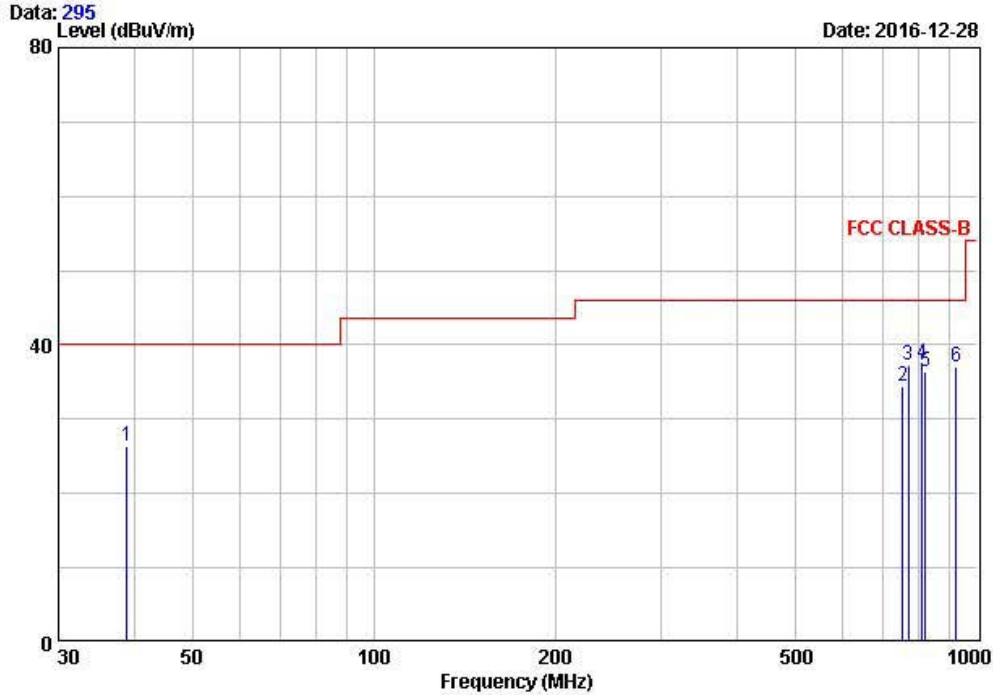

	Freq	Reading	C.F	Result	Limit	Margin	Height	Angle	Polarity
	MHz	dBuV	dB	dBuV/m	QP	dB	cm	deg	
1	38.90	44.50	-18.23	26.27	40.00	13.73	100	188	VERTICAL
2	754.10	36.10	-1.67	34.43	46.00	11.57	318	54	HORIZONTAL
3	768.90	38.60	-1.41	37.19	46.00	8.81	311	184	HORIZONTAL
4	810.40	38.10	-0.69	37.41	46.00	8.59	304	8	HORIZONTAL
5	821.40	36.80	-0.48	36.32	46.00	9.68	400	84	HORIZONTAL
6	924.10	35.60	1.55	37.15	46.00	8.85	311	77	HORIZONTAL

Remarks: C.F (Correction Factor) = Antenna factor + Cable loss - Preamp gain

**Radiated Emissions (Above 1 GHz) – 2.4GHz Bluetooth mode (LOW)**



EMI Chamber of LTA CO.,LTD.  
 4, Songjuro236Beon-gil, Yangji-myeon,  
 Yongin-si, Gyeonggi-do, Korea Autho.by NVLAP  
 Tel :+82-31-3236008,9 www.ltalab.com  
 Fax:+82-31-3236010

EUT/Model No. : CDL-3PBR

Test Mode: Bluetooth LOW mode

Tested by : BANG Y H

Temp/Humi: 19 / 43

Data: 136 File: D:\LTA\_e3\e3\_backup\1GHz 이상\2016\CH1\_ABOVE 1GHz\_1612-1.EMI (144) Date: 2016-12-27 Time: 18:28:11

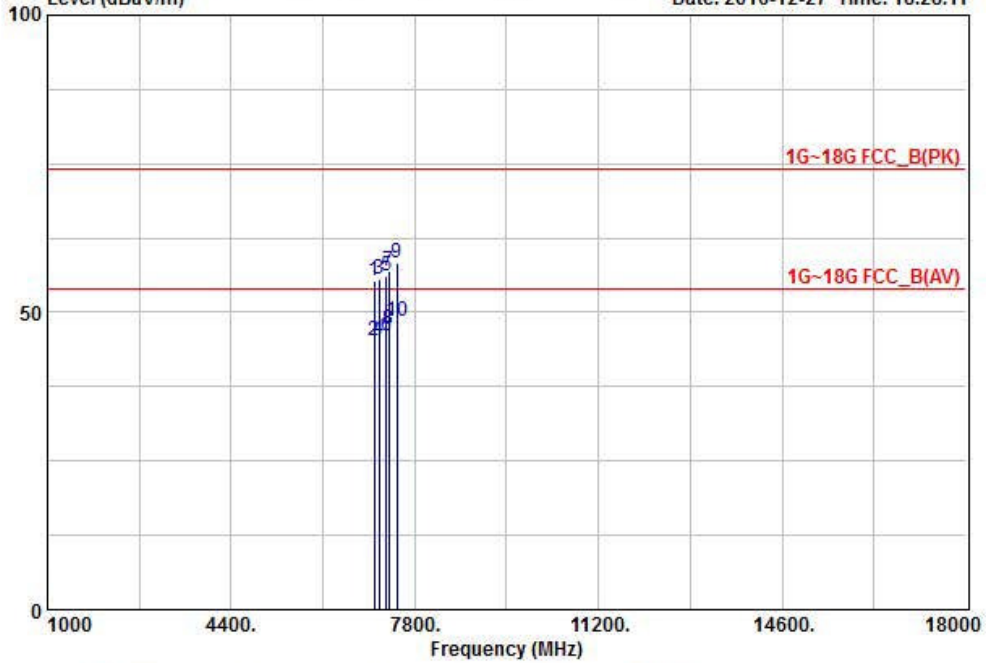

Freq	Reading	C.F	Result	Limit	Margin	Polarity
MHz	dBuV	dB	dBuV/m	dBuV/m	dB	
1 7054.12	33.40	21.83	55.23	74.00	18.77	HORIZONTAL
2 7054.12	23.40	21.83	45.23	54.00	8.77	HORIZONTAL
3 7146.12	32.80	22.84	55.64	74.00	18.36	HORIZONTAL
4 7146.12	22.80	22.84	45.64	54.00	8.36	HORIZONTAL
5 7266.50	31.90	24.15	56.05	74.00	17.95	HORIZONTAL
6 7266.50	21.90	24.15	46.05	54.00	7.95	HORIZONTAL
7 7314.65	32.40	24.68	57.08	74.00	16.92	HORIZONTAL
8 7314.65	22.40	24.68	47.08	54.00	6.92	HORIZONTAL
9 7462.65	32.10	26.30	58.40	74.00	15.60	HORIZONTAL
10 7462.65	22.10	26.30	48.40	54.00	5.60	HORIZONTAL

Remarks: C.F (Correction Factor) = Antenna factor + Cable loss - Preamp gain  
 Blue : Vertical Black : Horizontal



EMI Chamber of LTA CO.,LTD.  
 4, Songjuro236Beon-gil, Yangji-myeon,  
 Yongin-si, Gyeonggi-do, Korea Autho.by NVLAP  
 Tel :+82-31-3236008,9 www.ltalab.com  
 Fax:+82-31-3236010

EUT/Model No. : CDL-3PBR Test Mode: Bluetooth LOW mode  
 Tested by : BANG Y H Temp/Humi: 19 / 43

Data: 137 File: D:\LTA\_e3\3\_backup\1GHz 이상\2016\CH1\_ABOVE 1GHz\_1612-1.EMI (137)  
 Level (dBuV/m) Date: 2016-12-27 Time: 18:30:14

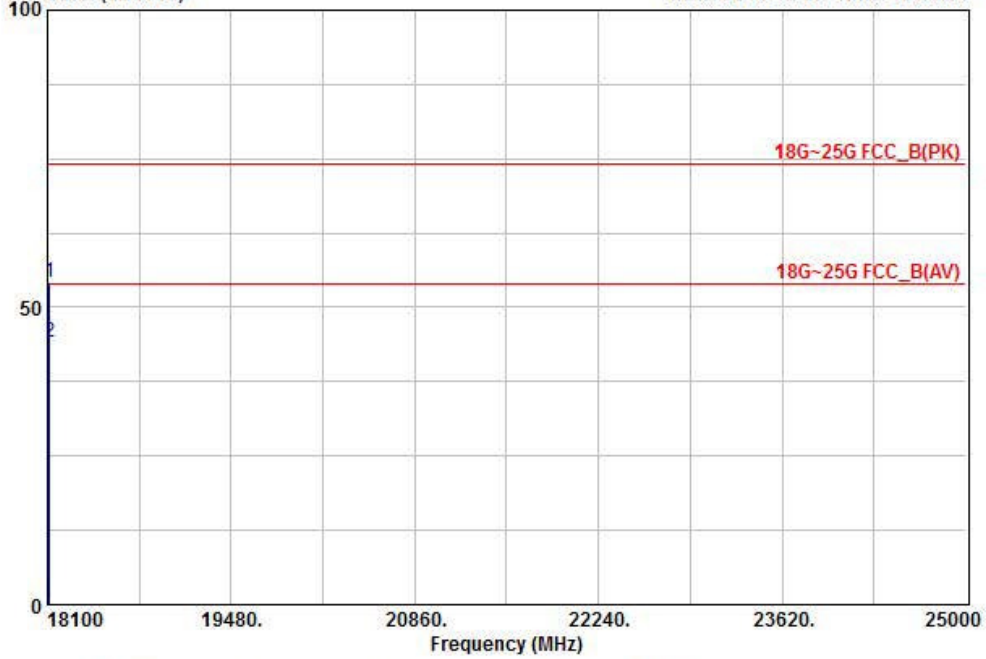

Freq	Reading	C.F	Result	Limit	Margin	Polarity
MHz	dBuV	dB	PK dBuV/m	dBuV/m	dB	
118112.40	41.10	13.11	54.21	74.00	19.79	HORIZONTAL
218112.40	31.10	13.11	44.21	54.00	9.79	HORIZONTAL

Remarks: C.F (Correction Factor) = Antenna factor + Cable loss - Preamp gain  
 Blue : Vertical Black : Horizontal

**Radiated Emissions (Above 1 GHz) – 2.4GHz Bluetooth mode (MID)**



EMI Chamber of LTA CO.,LTD.  
 4, Songjuro236Beon-gil, Yangji-myeon,  
 Yongin-si, Gyeonggi-do, Korea Autho.by NVLAP  
 Tel :+82-31-3236008,9 www.ltalab.com  
 Fax:+82-31-3236010

EUT/Model No. : CDL-3PBR

Test Mode: Bluetooth mid mode

Tested by : BANG Y H

Temp/Humi: 19 / 43

Data: 138 File: D:\LTA\_e3\3\_backup\1GHz 이상\2016\CH1\_ABOVE 1GHz\_1612-1.EMI (144) Date: 2016-12-27 Time: 11:11:34

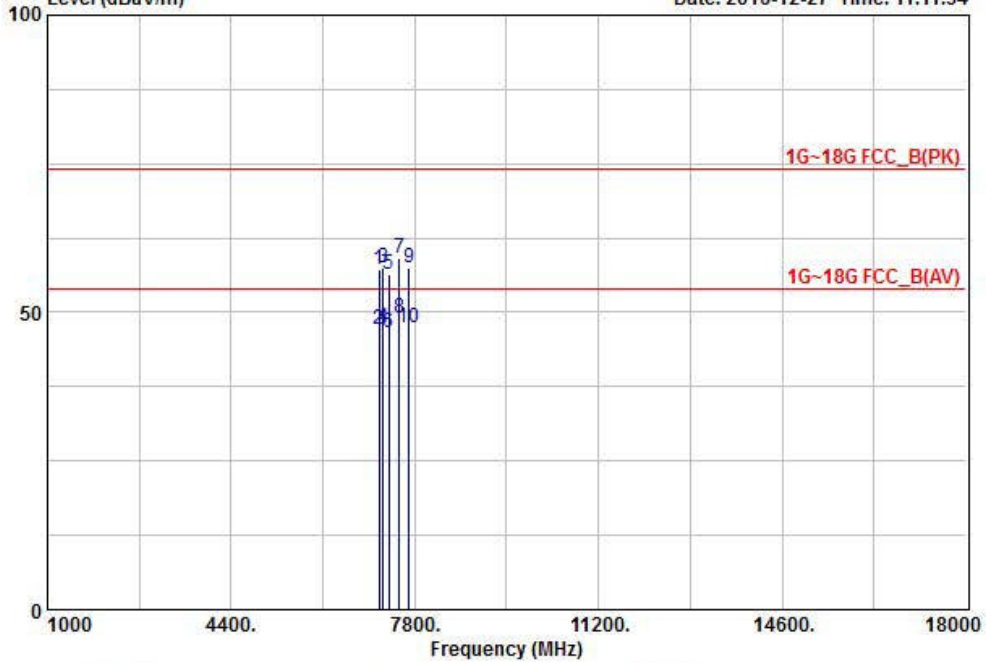

Freq	Reading	C.F	Result	Limit	Margin	Polarity	
MHz	dBuV	dB	PK dBuV/m	dBuV/m	dB		
1	7144.56	34.40	22.82	57.22	74.00	16.78	HORIZONTAL
2	7144.56	24.40	22.82	47.22	54.00	6.78	HORIZONTAL
3	7216.45	33.80	23.61	57.41	74.00	16.59	HORIZONTAL
4	7216.45	23.80	23.61	47.41	54.00	6.59	HORIZONTAL
5	7318.99	31.80	24.73	56.53	74.00	17.47	HORIZONTAL
6	7318.99	21.80	24.73	46.53	54.00	7.47	HORIZONTAL
7	7511.45	32.40	26.65	59.05	74.00	14.95	HORIZONTAL
8	7511.45	22.40	26.65	49.05	54.00	4.95	HORIZONTAL
9	7695.54	31.80	25.75	57.55	74.00	16.45	HORIZONTAL
10	7695.54	21.80	25.75	47.55	54.00	6.45	HORIZONTAL

Remarks: C.F (Correction Factor) = Antenna factor + Cable loss - Preamp gain  
 Blue : Vertical Black : Horizontal



EMI Chamber of LTA CO.,LTD.  
 4, Songjuro236Beon-gil, Yangji-myeon,  
 Yongin-si, Gyeonggi-do, Korea Autho.by NVLAP  
 Tel :+82-31-3236008,9 www.ltalab.com  
 Fax:+82-31-3236010

EUT/Model No. : CDL-3PBR Test Mode: Bluetooth mid mode  
 Tested by : BANG Y H Temp/Humi: 19 / 43

Data: 139 File: D:\LTA\_e3\3\_backup\1GHz 이상\2016\CH1\_ABOVE 1GHz\_1612-1.EMI (139)  
 Level (dBuV/m) Date: 2016-12-27 Time: 11:14:33

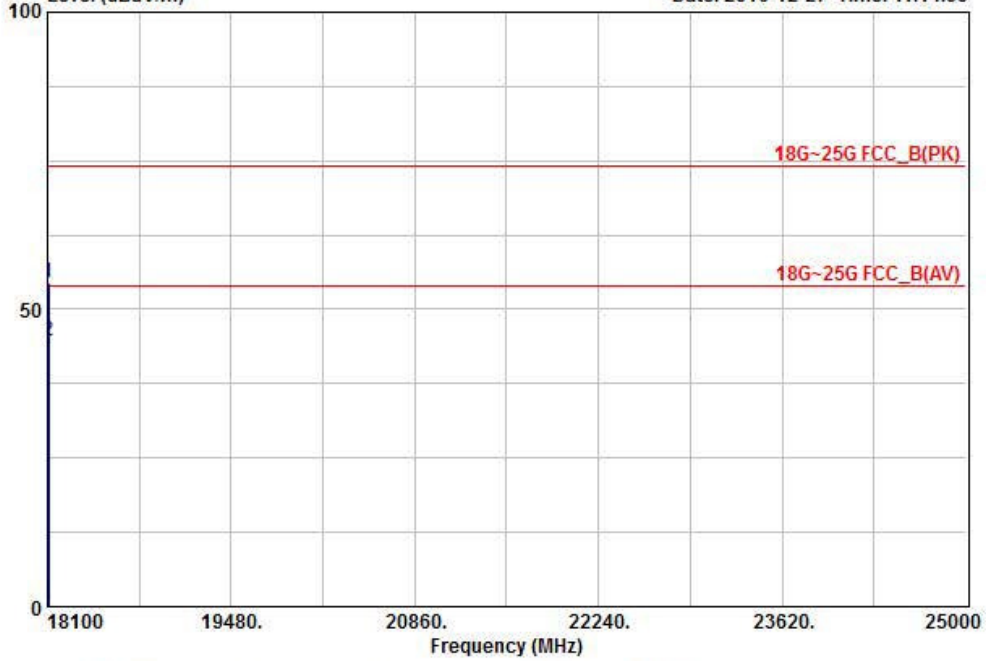

Freq	Reading	C.F	Result	Limit	Margin	Polarity
MHz	dBuV	dB	PK dBuV/m	dBuV/m	dB	
11811.40	41.50	13.11	54.61	74.00	19.39	HORIZONTAL
21811.40	31.50	13.11	44.61	54.00	9.39	HORIZONTAL

Remarks: C.F (Correction Factor) = Antenna factor + Cable loss - Preamp gain  
 Blue : Vertical Black : Horizontal

**Radiated Emissions (Above 1 GHz) – 2.4GHz Bluetooth mode (HIGH)**



EMI Chamber of LTA CO.,LTD.  
 4, Songjuro236Beon-gil, Yangji-myeon,  
 Yongin-si, Gyeonggi-do, Korea Autho.by NVLAP  
 Tel :+82-31-3236008,9 www.ltalab.com  
 Fax:+82-31-3236010

EUT/Model No. : CDL-3PBR

Test Mode: Bluetooth High mode

Tested by : BANG Y H

Temp/Humi: 19 / 43

Data: 140 File: D:\LTA\_e3\3\_backup\1GHz 이상\2016\CH1\_ABOVE 1GHz\_1612-1.EMI (144) Date: 2016-12-27 Time: 10:23:12  
 Level (dBuV/m)

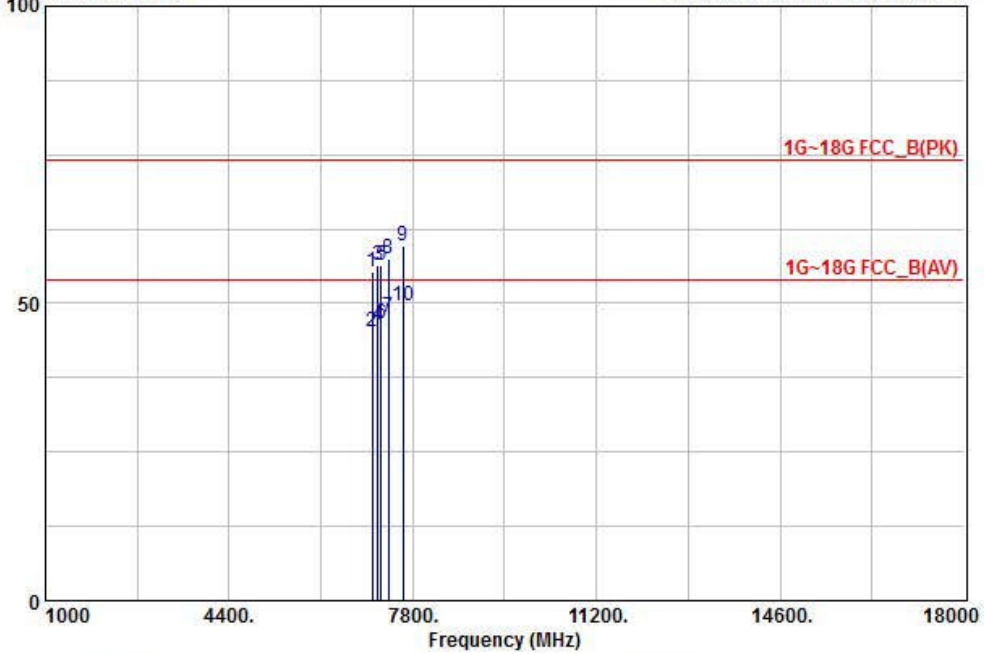

Freq MHz	Reading dBuV	C.F dB	Result PK dBuV/m	Limit dBuV/m	Margin dB	Polarity
1 7054.84	33.40	21.84	55.24	74.00	18.76	HORIZONTAL
2 7054.84	23.40	21.84	45.24	54.00	8.76	HORIZONTAL
3 7154.40	33.50	22.93	56.43	74.00	17.57	HORIZONTAL
4 7154.40	23.50	22.93	46.43	54.00	7.57	HORIZONTAL
5 7215.40	32.90	23.60	56.50	74.00	17.50	HORIZONTAL
6 7215.40	22.90	23.60	46.50	54.00	7.50	HORIZONTAL
7 7354.90	22.50	25.12	47.62	54.00	6.38	HORIZONTAL
8 7354.90	32.50	25.12	57.62	74.00	16.38	HORIZONTAL
9 7614.12	33.50	26.15	59.65	74.00	14.35	HORIZONTAL
10 7614.12	23.50	26.15	49.65	54.00	4.35	HORIZONTAL

Remarks: C.F (Correction Factor) = Antenna factor + Cable loss - Preamp gain  
 Blue : Vertical Black : Horizontal





EMI Chamber of LTA CO.,LTD.  
 4, Songjuro236Beon-gil, Yangji-myeon,  
 Yongin-si, Gyeonggi-do, Korea Autho.by NVLAP  
 Tel :+82-31-3236008,9 www.ltalab.com  
 Fax:+82-31-3236010

EUT/Model No. : CDL-3PBR Test Mode: BLE HIGH mode  
 Tested by : BANG Y H Temp/Humi: 19 / 43

Data: 141 File: D:\LTA\_e3\3\_backup\1GHz 이상\2016\CH1\_ABOVE 1GHz\_1612-1.EMI (141)  
 Level (dBuV/m) Date: 2016-12-27 Time: 10:26:32

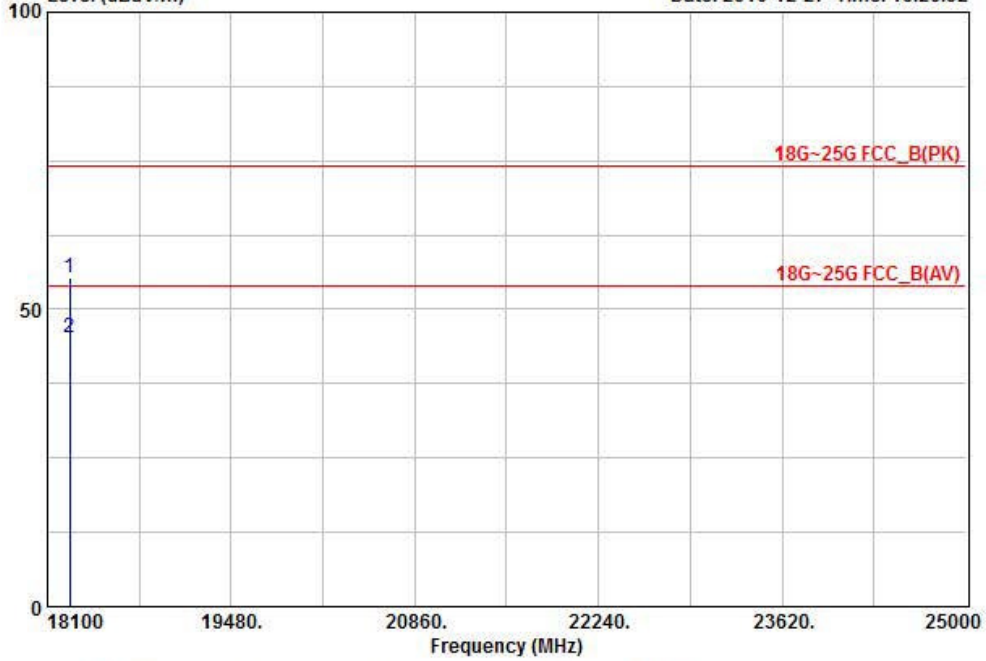

Freq	Reading	C.F	Result	Limit	Margin	Polarity
MHz	dBuV	dB	PK dBuV/m	dBuV/m	dB	
118264.40	42.10	13.22	55.32	74.00	18.68	HORIZONTAL
218264.40	32.10	13.22	45.32	54.00	8.68	HORIZONTAL

Remarks: C.F (Correction Factor) = Antenna factor + Cable loss - Preamp gain  
 Blue : Vertical Black : Horizontal

## APPENDIX

### TEST EQUIPMENT USED FOR TESTS

	Description	Model No.	Serial No.	Manufacturer	Interval	Last Cal. Date
1	Signal Analyzer (9 kHz ~ 30 GHz)	FSV-30	100757	R&S	1 year	2016-03-22
2	Signal Generator (~3.2 GHz)	8648C	3623A02597	HP	1 year	2016-03-21
3	SYNTHESIZED CW GENERATOR	83711B	US34490456	HP	1 year	2016-03-21
4	Attenuator (3 dB)	8491A	37822	HP	1 year	2016-09-12
5	Attenuator (10 dB)	8491A	63196	HP	1 year	2016-09-12
6	Test Receiver (~30 MHz)	ESHS10	828404/009	R&S	1 year	2016-03-21
7	EMI Test Receiver (~7 GHz)	ESCI7	100722	R&S	1 year	2016-09-12
8	RF Amplifier (~1.3 GHz)	8447D OPT 010	2944A07684	HP	1 year	2016-09-12
9	RF Amplifier (1~26.5 GHz)	8449B	3008A02126	HP	1 year	2016-03-21
10	Horn Antenna (1~18 GHz)	3115	00114105	ETS	1 year	2016-04-21
11	DRG Horn (Small)	3116B	81109	ETS-Lindgren	1 year	2016-05-03
12	DRG Horn (Small)	3116B	133350	ETS-Lindgren	1 year	2016-05-03
13	TRILOG Antenna	VULB 9160	9160-3237	SCHWARZBECK	2 year	2015-04-21
14	Temp.Humidity Data Logger	SK-L200TH II A	00801	SATO	1 year	2016-03-22
15	Splitter (SMA)	ZFSC-2-2500	SF617800326	Mini-Circuits	-	-
16	Power Divider	11636A	06243	HP	1 year	2016-09-12
17	DC Power Supply	6674A	3637A01657	Agilent	-	-
18	Frequency Counter	5342A	2826A12411	HP	1 year	2016-03-21
19	Power Meter	EPM-441A	GB32481702	HP	1 year	2016-03-22
20	Power Sensor	8481A	3318A94972	HP	1 year	2016-12-31
21	Audio Analyzer	8903B	3729A18901	HP	1 year	2016-09-12
22	Modulation Analyzer	8901B	3749A05878	HP	1 year	2016-09-12
23	TEMP & HUMIDITY Chamber	YJ-500	LTAS06041	JinYoung Tech	1 year	2016-09-12
24	Stop Watch	HS-3	812Q08R	CASIO	2 year	2016-03-22
25	LISN	KNW-407	8-1430-1	Kyoritsu	1 year	2016-09-12
26	Two-Lime V-Network	ESH3-Z5	893045/017	R&S	1 year	2016-03-21
27	UNIVERSAL RADIO COMMUNICATION TESTER	CMU200	106243	R&S	1 year	2016-03-21
28	Highpass Filter	WHKX1.5/15G-10SS	74	Wainwright Instruments	1 year	2016-03-21
29	Highpass Filter	WHKX3.0/18G-10SS	118	Wainwright Instruments	1 year	2016-03-21
30	Active Loop Antenna	FMZB1519	1519-031	SCHWARZBECK	2 year	2016-01-12
31	OSP120 BASE UNIT	OSP120	101230	R&S	1 year	2016-03-22
32	Signal Generator(100 kHz ~ 40 GHz)	SMB100A03	177621	R&S	1 year	2016-03-22
33	Signal Analyzer (10 Hz ~ 40 GHz)	FSV40	101367	R&S	1 year	2016-03-22