

Verification

*With The 47 CFR, Part2 and Part15
Of FCC Requirement*

Hereby certifies that

Type of device: All other devices

Category: Digital Door Lock

Model No.: CDL-3PBR

Additional Model name: -

Manufactures and address

COMMAX Co.,Ltd

**513-11, sangdaewon-dong, Jungwon-gu, Seongnam-si, Gyeonggi-do,
South Korea**

This document is the proof that above product, system, and also relates OEM models are complying with FCC requirement. We, LTA Co., Ltd is the accredited EMC laboratory for NVLAP(US), RRA(KOREA). We certify that the above products had performed test on our laboratory and it was confirmed to comply with FCC requirement. These products might be marketed at the US accordance to DoC of FCC Rule based on the standard 47CFR Part 2 and 15. The test was performed accordance to the procedures from ANSI C63.4-2014. Test data and results are issue on the EMC test report No. as follows.

Reference Endorsed Test Report No. is LR500111612M

Date: December 29, 2016



Won Wook Kim, Technical Manager
LTA Co., Ltd.



NVLAP LAB CODE 200723-0

TEST REPORT

This laboratory is accredited by Radio Research Laboratory and National Voluntary Laboratory Accreditation Program. The tests reported herein have been performed in accordance with its terms of accreditation.

Test Report No. : LR500111612M
Issue Date : December 29, 2016
Applied Standard : FCC Part 15, Subpart B
Trade Name : COMMAX Co.,Ltd
Category : Digital Door Lock
Model Name : CDL-3PBR
Additional Model name : -
Serial Number : Identification

This test result only responds to the tested sample. It is not allowed to copy this report even partly without the allowance of the test laboratory. The report must not be used by the client to claim product certification, approval, or endorsement by NVLAP, NIST, or any agency of the Federal Government.



NVLAP LAB CODE 200723-0

Revision history

Revision	Date of issue	Test report No.	Description
0	12.29.2016	LR500111612M	Initial

TABLE OF CONTENTS

<u>Text</u>	<u>Page</u>
Contents -----	3
LTA Certification -----	4
General Information -----	6
Brief Information -----	7
Test site description -----	10
Test Procedure -----	12
List of test equipment used for the test -----	15
Radiated disturbance measurement (Result & Graph) -----	16
Conclusions -----	21

★ ★ ★ ★ ★ ★ ★ ★ ★ ★ ★ ★ ★ ★ ★ ★

LTA Certification

Applicant / Manufacture

Company name : COMMAX Co.,Ltd
Address : 513-11, sangdaewon-dong, Jungwon-gu, Seongnam-si, Gyeonggi-do, South Korea
Telephone /Facsimile : +82-31-739-3682 / +82-31-739-3649

Factory 1

Company name : COMMAX Co.,Ltd
Address : 513-11, sangdaewon-dong, Jungwon-gu, Seongnam-si, Gyeonggi-do, South Korea

Equipment Under Test (EUT)

Category : Digital Door Lock
Brand : COMMAX Co.,Ltd
Model name : CDL-3PBR
Serial number : Identification
Intended environment : Residential area
Date of receipt : October 18, 2016
EUT condition : Pre-production, not damaged
Operating Mode : Bluetooth/Operating/Zigbee/RFID Mode
Interface ports : DC IN
Power rating : DC 6 V
Test memory size : -
Crystal/Oscillator(s) : -
Firmware version : XXXX

*** To be continued next page ***

LTA Certification –cont.-

Model Description

- NONE

Model Specification

- NONE

Test Performed

Test started & completed : November 28-29, 2016

Location : LTA Co., Ltd.

Test Specification

Purpose of the test : Compliance test to the following standard

Applied standard : FCC Part 15, Subpart B

Classification : Class B

Deviations from Standard : N/A

Test Method

Test Results

Measurement	Results*	Test method
Radiated disturbance	Complies	ANSI C 63.4-2014
Conducted disturbance	Complies	ANSI C 63.4-2014

* : The compliance statement is based on nominal value only.

Modification performed by the lab.;

- N.A

-We were performed the test according to LTA procedure LTA-QI-04.

Laboratory's Certificate

Report number : LR500111612M

Issue date : December 02, 2016

This test report is issued under the authority of:

The test was supervised by:



Won Wook Kim, Technical Manager



Young Ho Bang, Test Engineer

The results in this report apply only to the sample(s) tested.

It is not allowed to copy this report even partly without the allowance of the test laboratory.

General information's

Purpose

This document is based on the Electromagnetic Interference (EMI) tests performed on the “CDL-3PBR”. The measurements were performed according to the measurement procedure described in ANSI C 63.4-2014. The tests were carried out in order to confirm whether the electromagnetic emissions from the EUT(Equipment Under Test), are within the class A limits defined in FCC Part 15, Subpart B- “Section 15.107- Conducted limits” and “Section 15.109-Radiated emission limits”.

Test Performed

Company name : LTA Co., Ltd.
 Address : 243, Jubug-ri, Yangji-Myeon, Youngin-Si, Kyunggi-Do, Korea. 449-822
 Telephone : +82-31-323-6008
 Facsimile : +82-31-323-6010

Measurement uncertainty

Radiated disturbance (30 to 1000MHz) : +3.94 [dB] , -3.94 [dB] (k=2)
 (1GHz to 18GHz) +3.46 [dB] , -3.46 [dB] (k=2)
 Conducted disturbance (0.15 to 30MHz) : +1.46[dB] , -1.46 [dB] (k=2)

The coverage factor k=2 yields approx. a 95% level of confidence for near-normal distribution typical of most measurement results.

Accredited agencies

LTA Co., Ltd. Is approved to perform EMC testing by the following agencies:

Agency	Country	Accreditation No.	Validity	Reference
NVLAP	U.S.A	200723-0	2017-09-30	ECT accredited Lab.
RRA	KOREA	KR0049	-	EMC accredited Lab.
FCC	U.S.A	610755	2017-04-21	FCC filing
FCC	U.S.A	649054	2017-04-13	FCC CAB
VCCI	JAPAN	R-2133(10 m), C-2307	2017-06-21	VCCI registration
VCCI	JAPAN	T-2009	2016-12-23	VCCI registration
VCCI	JAPAN	G-847	2018-12-13	VCCI registration
IC	CANADA	5799A-1	2019-11-07	IC filing
KOLAS	KOREA	NO.551	2017-01-08	KOLAS accredited Lab.

Brief Information

1-1 Test Summary

Parameter	Applied Standard	Status (note 1)
I. Emission		
Radiated disturbance	FCC Part 15.109	C
Conducted disturbance	FCC Part 15.107	C
Note 1: C=Complies NC=Not Complies NT=Not Tested NA=Not Applicable * The data in this test report are traceable to the national or international standards.		

Frequency range to be scanned:

0.15 MHz - 30 MHz as conducted measurement

5th harmonic of the highest frequency or 40 GHz, whichever is lower

Bandwidth:

Measured by the CISPR quasi-peak function Bandwidth is 9 kHz in the frequency 0.15 MHz to 30 MHz and 120 kHz in the frequency 30 MHz to 1,000 MHz.

Measured by the CISPR Peak function Bandwidth is 1MHz in the frequency 1 GHz to 40 GHz.

A sample calculation:

COR. F (correction factor)= Antenna factor + Cable loss- Amp.gain- Distance correction

Emission Level= meter reading + COR.F

1-2 Variant Model

- NONE

1-3 Bluetooth/Operating/Zigbee/RFID Mode of the EUT

The tests have been conducted with the following operational mode(s) of the EUT.

Name of mode in the report	Description
Operating / Zigbee / Bluetooth / RFID Mode	: Operating / Zigbee / Bluetooth / RFID Mode

1-4 Modification

None

1-5 List of EUT and accessory

EUT				
Category	Model Name	Serial No.	Manufacturer	Remarks
Digital Door Lock	CDL-3PBR	N/A	COMMAX Co.,Ltd	-

ACCESSORY				
Category	Model Name	Serial No.	Manufacturer	Remarks
Battery	N/A	N/A	N/A	AA size 8EA
Mobile phone	Galaxy 3	N/A	SAMSUNG	-
RFID Chip	N/A	N/A	COMMAX Co.,Ltd	2GB

1-6 Cable List

Cable List (Lighting mode)				
Type	Length (m)	Shielding (Cable/backshell)	Remarks	
			From	to
Battery	-	-	DC IN	DC OUT

1-7 Block diagram of the EUT test (Operating/Zigbee Mode)

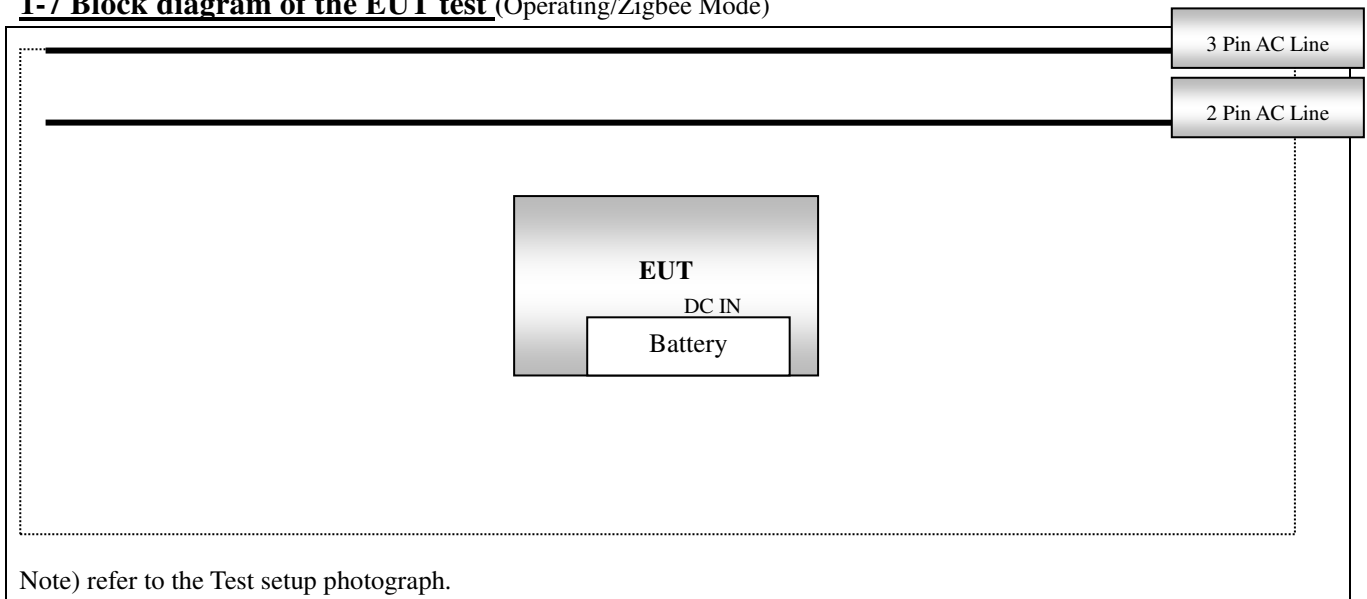

1-7 Block diagram of the EUT test (Bluetooth Mode)

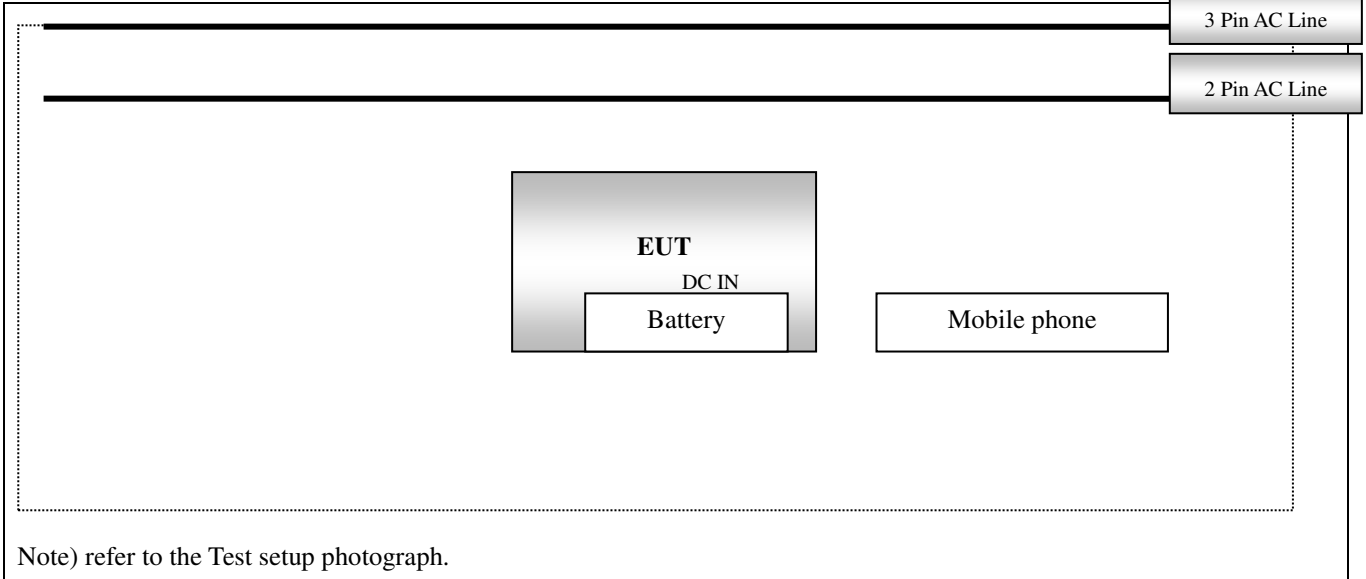

1-7 Block diagram of the EUT test (RFID Mode)

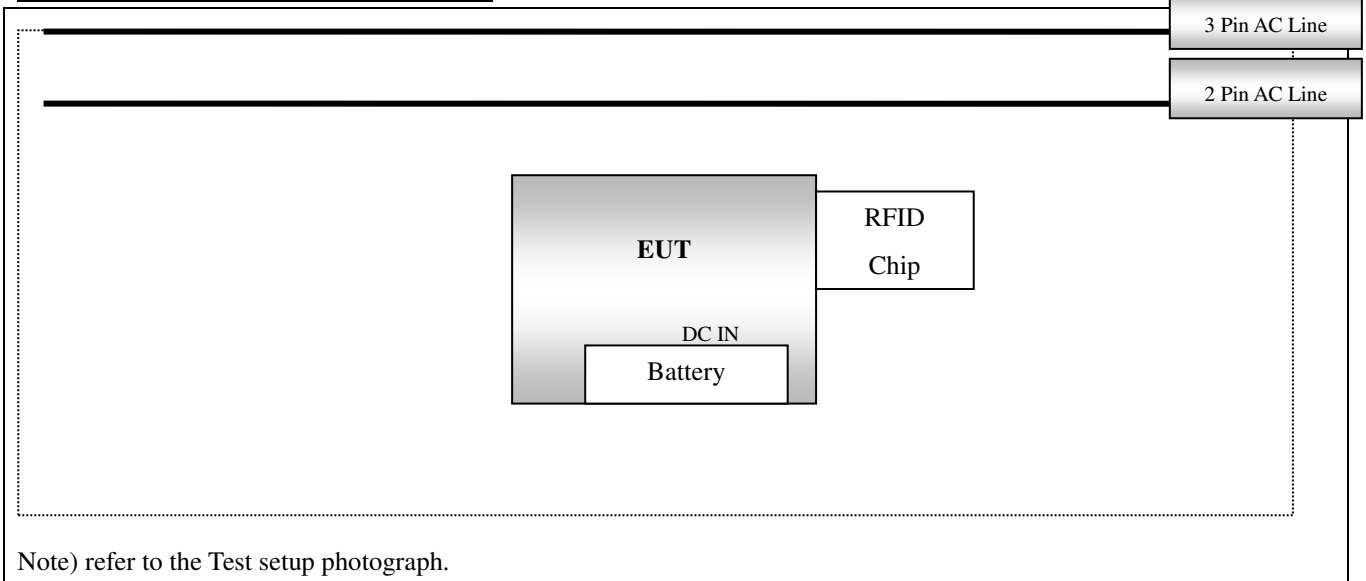

2- Test Site Description

1-Facility

All the testing facilities are periodically serviced as a daily check for equipment and cables systems, an every 6 months facility check for the facilities and a monthly check and annual calibration for testing equipment according to ISO/IEC 17025. All the testing facilities are used as the same specifications shown below. There are descriptions both for radiated disturbance measurement and conducted disturbance measurement conformed by ANSI C 63.4-2014. The NSA measurement of the OATS was performed on July 01, 2015 according to ANSI C 63.4-2014.

2-1 Radiated Disturbance Measurement – Below 1GHz

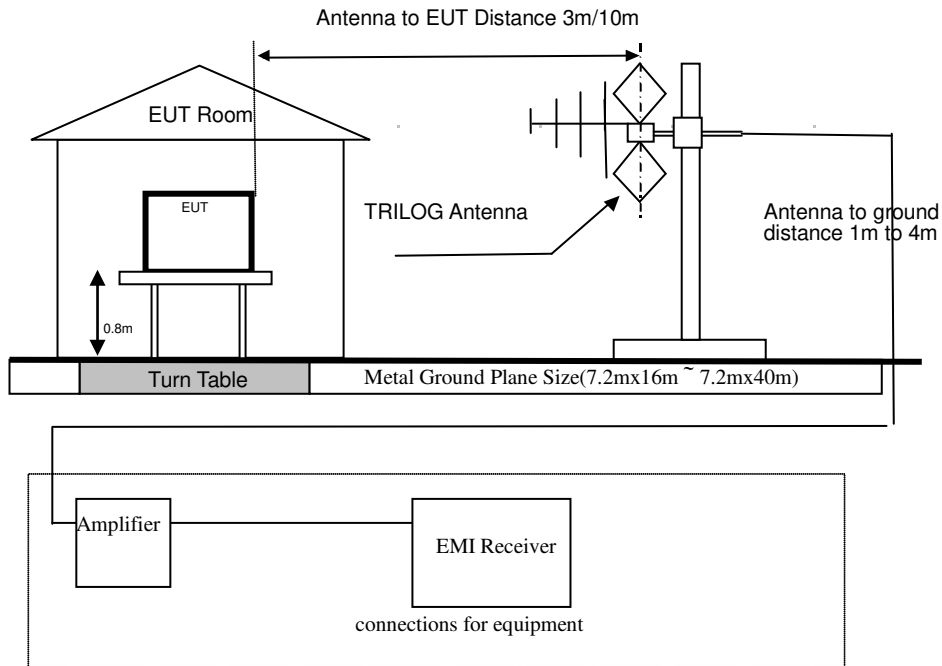

2-2 Conducted Disturbance Measurement

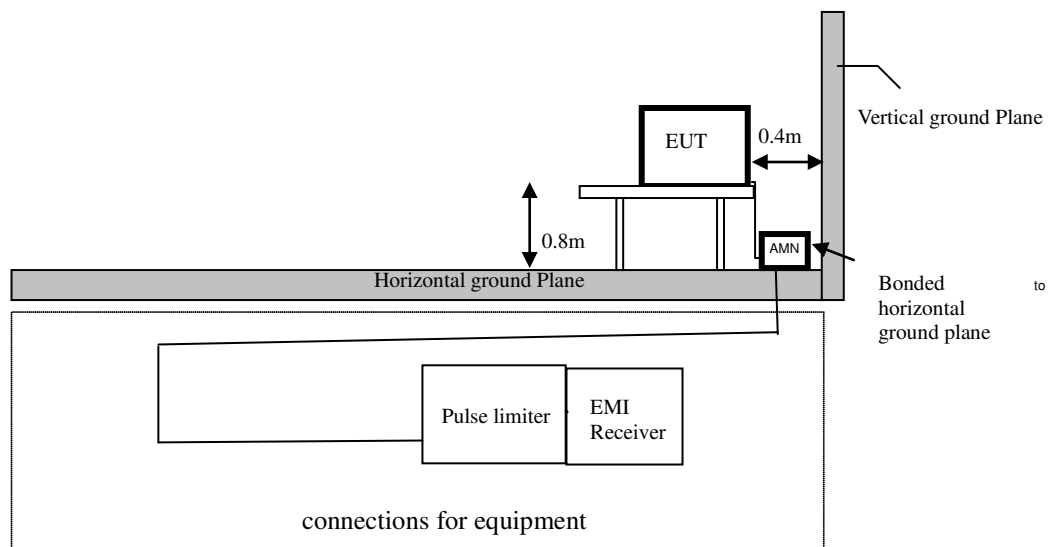

2-3 Radiated Disturbance Measurement – Above 1GHz

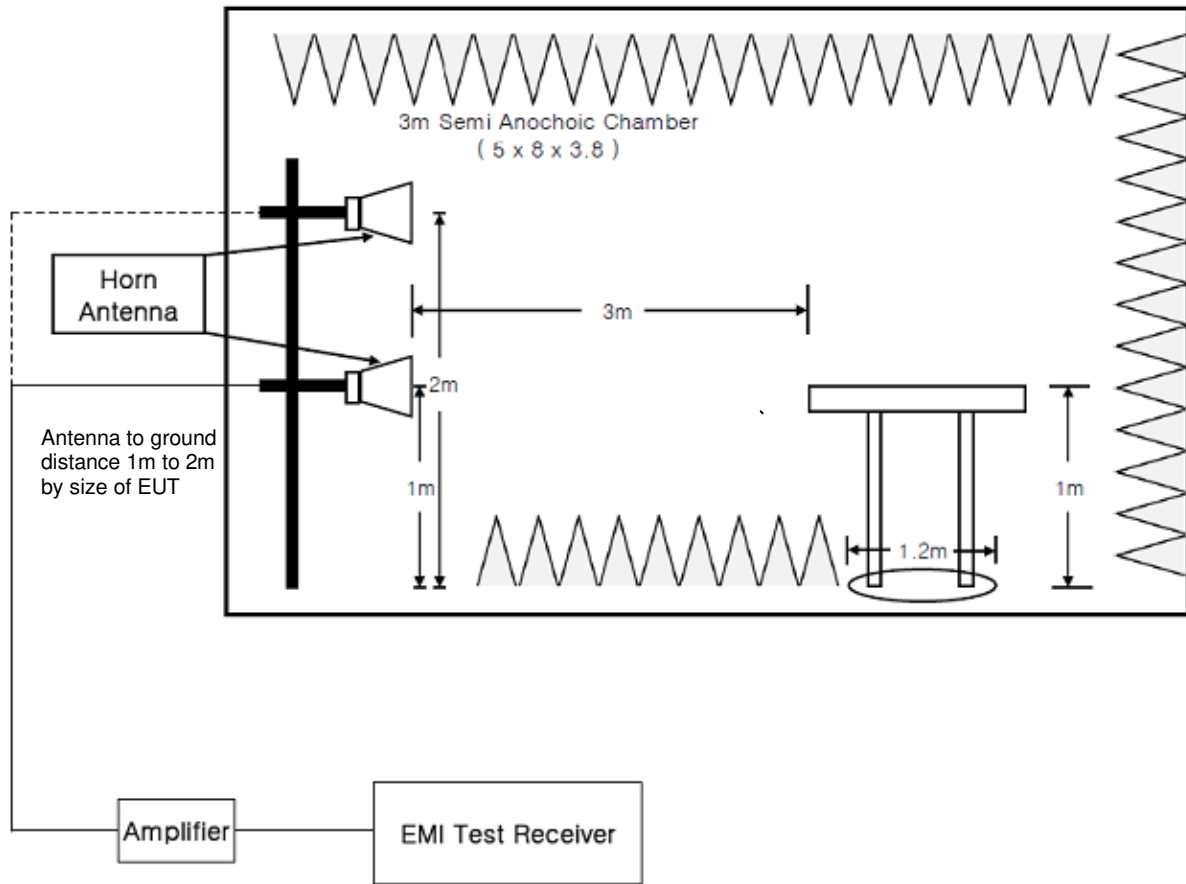

3- Test Procedure

3-1 Radiated Disturbance Measurements – Below 1GHz

- Test site is met the requirements of ANSI C 63.4-2014 and the distance between the EUT and the antenna is adjusted 3 m/10 m.
- The turntable can be rotated 360 degrees.
- The antenna can be adjusted between 1m and 4m in height above the ground.
- The EUT is placed on the non-conducting table with 0.8m height on the turntable.
- Measurements are carried out using a EMI test receiver with peak detectors (100 kHz bandwidth) and an EMI receiver with quasi-peak detectors(120 kHz bandwidth).
- Refer to the list of test equipment used for the test.
- TRILOG antenna are used as wideband antenna.
- The TRILOG antenna is used in the frequency range of 30 MHz to 1 000 MHz, the Horn antenna is used in the frequency range of 1GHz to 18 GHz.
- A variable attenuator is used for verifying amplifier's linearity.
- Rotating the turntable and adjusting the height of the antenna are carried out by control buttons on the console.
- Refer to "Brief Information"(page 7-8) about details of the EUT and configuration of the cables.

- Measurement is carried out by a LTA operator as manual operation.
 - searching for some of High disturbance frequency points than the other points with the following settings; bandwidth 100 kHz, frequency range 10 MHz between 30MHz and 300 MHz and frequency range 50 MHz between 300 MHz and 1 GHz.
 - searching the worst direction with the maximum level of the disturbance wave in rotating the turntable 360 degrees at each searched frequency point.
 - setting the height of the antenna with the maximum level of the disturbance wave from 1m to 4m.
 - reading the disturbance level by the EMI receiver with quasi-peak detectors (120 kHz bandwidth) according to ANSI C 63.4-2014.
 - measuring to vertical and horizontal polarization.
 - calculating the measurement result with the following formula or equation:
(Measurement result= measured value + antenna factor + antenna cable loss)

3-2 Conducted Disturbance Measurements

- The measurement is carried out on an open site with horizontal and metallic ground plane.
- An AMN(Artificial Mains Network) with a nominal impedance ($50 \Omega/50 \mu\text{H}$) as defined in ANSI C 63.4-2014., shall be utilized.
- The AMN is grounded on a horizontal metal ground plane.
- Measurement is carried out using an EMI receiver with quasi-peak detectors and average detector.
(Refer to the List of test equipment used for the test.)
- The shortest distance between the EUT and the AMN is 0.8m.
- The EUT is placed on the non-conducting table with 0.8m height.
- A remote switch is used for changing phases between Line (L) and Neutral (N).
- Refer to "Brief Information"(page 5-8) about details of the EUT and configuration of the cables.

- Measurement is carried out as manual operation.
 - detecting the maximized emission level using the maxhold function after setting the spectrum analyzer bandwidth 1KHz and the frequency range from 150 kHz to 1 MHz , 1 MHz to 5 MHz and 5 MHz to 30 MHz.
 - searching the maximum frequency point of the disturbance wave in each frequency range.
 - reading the disturbance level of quasi-peak, average and Line (L) and Neutral (N) in 9 kHz bandwidth by the EMI receiver.
 - calculating the measurement result with the following formula or equation.
(Result = Reading + Cor.F.)
(Margin = Limit- Result)

3-3 Radiated Disturbance Measurements – Above 1GHz

- Test site is met the requirements of ANSI C 63.4-2014 and the distance between the EUT and the antenna is adjusted 3m.
- The turntable can be rotated 360 degrees.
- The antenna can be adjusted between 1m in height above the ground.
- The EUT is placed on the non-conducting table with 1m height on the turntable.
- Measurements are carried out using a EMI test receiver with peak detectors (1 MHz bandwidth) and an EMI receiver with peak and average detectors(1 MHz bandwidth).
- Refer to the list of test equipment used for the test.
- HORN antenna are used as wideband antenna.
- The HORN antenna is used in the frequency range of 1 GHz to 18 GHz.
- A variable attenuator is used for verifying amplifier's linearity.
- Rotating the turntable and adjusting the height of the antenna are carried out by control buttons on the console.
- Refer to "Brief Information"(page 7-8) about details of the EUT and configuration of the cables.
- Measurement is carried out by a LTA operator as manual operation.
 - searching the worst direction with the maximum level of the disturbance wave in rotating the turntable 360 degrees at each searched frequency point.
 - setting the height of the antenna with the maximum level of the disturbance wave from 1 m
 - reading the disturbance level by the EMI receiver with peak and average detectors (1MHz bandwidth) according to ANSI C 63.4-2014.
 - measuring to vertical and horizontal polarization.
 - calculating the measurement result with the following formula or equation:
(Measurement result= measured value + antenna factor + antenna cable loss)

4- List of Equipment Used For the Tests

	Item	Model Name	Serial No.	Manufacturer	Inter val	Last Cal.
1	EMI TEST Receiver	ESR	101499	R&S	1 year	Jul-16
2	Two-Line V-Network <MAIN>	ENV216	32031518210	AFJ	1 year	Oct-16
3	LINE <SUB>	ESH3-Z5	893045/017	R&S	1 year	Mar-16
4	TRILOG Antenna	VULB 9160	9160-3237	SCHWARZBECK	2 year	May-16
5	HORN ANTENNA	3115	00114105	ETS	2 year	Aug-16
6	Amplifier (1 - 18GHz)	8449B	3008A02126	Agilent	1 year	Mar-16
7	ABSORBING CLAMP	MDS21	3665	SCHWARZBECK	1 year	Sep-16
8	One-Line V-NETWORK	ESH3-Z6	100378	R&S	1 year	Sep-16
9	Pulse Limiter	ESH3-Z2	100710	R&S	1 year	Mar-16
10	RF Amplifier(-1GHz)	8447D	2439A09058	HP	1 year	Sep-16
11	e3 software	e3	5.5.201a	AUDIX	-	-
12	Impedance Stabilization Network	ISN T800	27109	TESEQ	1 year	Jan-16
13	Impedance Stabilization Network	ENY81-CA6	101565	R&S	1 year	Feb-16
14	EZ-17 RF-CURRENT PROBE	EZ-17	100508	ROHDE&SCHWARZ	1 year	Jan-16
15	Attenuator (3dB)	8491A	37822	HP	1 year	Sep-16
16	Attenuator (10dB)	8491A	63196	HP	1 year	Sep-16
17	Hygro-Thermograph	THB-36	0041557-01	ISUZU	1 year	Sep-16
18	Mini-Circuits Splitter	ZFSC-2-2500	SF617800326	Mini-Circuits	N/A	N/A
19	Mini-Circuits Splitter	ZFM-150	15542	Mini-Circuits	N/A	N/A
20	Spectrum Analyzer (-2.9GHz)	8594E	3710A04074	HP	1 year	Mar-16
21	Test Receiver(~30MHz)	ESHS10	828404/009	R&S	1 year	Mar-16
22	DIGITAL THERMO HYGROMETER	TH-611	NONE	BODYCOM	1 year	Sep-16

5-1 Radiated Disturbance Measurements (Below 1GHz)_ Operating Mode



4, Songjuro236Beon-gil, Yangji-myeon,
Cheoin-gu, Youngin-si, Gyeonggi-do,
449-822 Korea
Tel +82-31-3236008,9
Fax:+82-31-3236010

EUT/Model No.: CDL-3PBR

TEST MODE: Operating mode

Temp Humi : 0 / 50

Tested by: BANG Y H

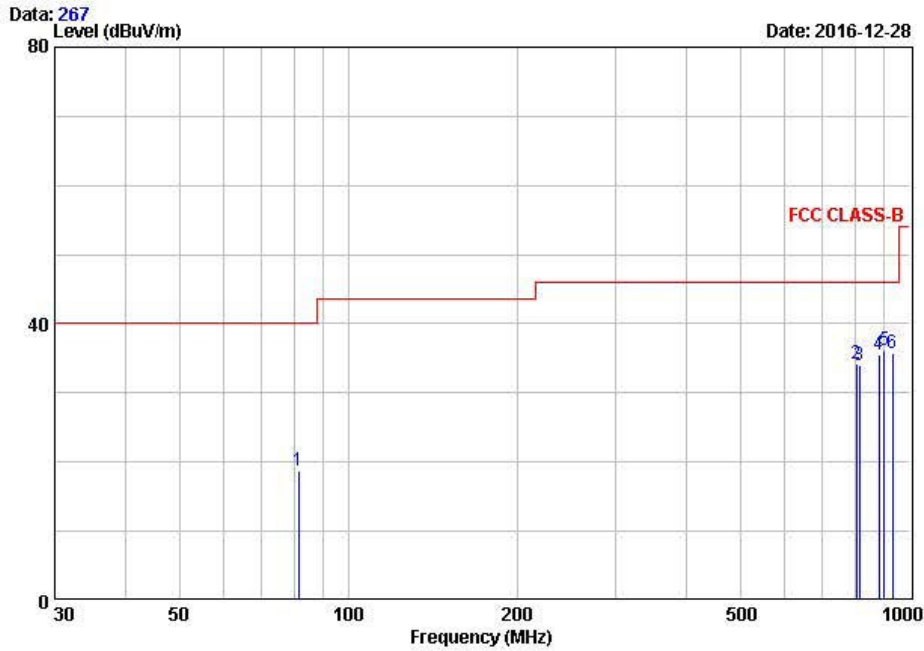

	Freq	Reading	C.F	Result	Limit	Margin	Height	Angle	Polarity
	MHz	dBuV	dB	dBuV/m	dBuV/m	dB	cm	deg	
1	81.60	40.20	-21.37	18.83	40.00	21.17	100	11	VERTICAL
2	804.60	35.10	-0.80	34.30	46.00	11.70	244	185	HORIZONTAL
3	814.20	34.60	-0.62	33.98	46.00	12.02	119	93	HORIZONTAL
4	882.60	34.80	0.72	35.52	46.00	10.48	219	11	HORIZONTAL
5	900.65	35.20	1.08	36.28	46.00	9.72	219	54	HORIZONTAL
6	933.40	34.10	1.73	35.83	46.00	10.17	100	151	VERTICAL

Remarks: C.F (Correction Factor) = Antenna factor + Cable loss - Preamp gain

5-1 Radiated Disturbance Measurements (Below 1GHz)_ Bluetooth(Low) Mode



4, Songjuro236Beon-gil, Yangji-myeon,
Cheoin-gu, Youngin-si, Gyeonggi-do,
449-822 Korea
Tel :+82-31-3236008,9
Fax:+82-31-3236010

EUT/Model No.: CDL-3PBR TEST MODE: BLE LOW mode
Temp Humi : 0 / 50 Tested by: BANG Y H

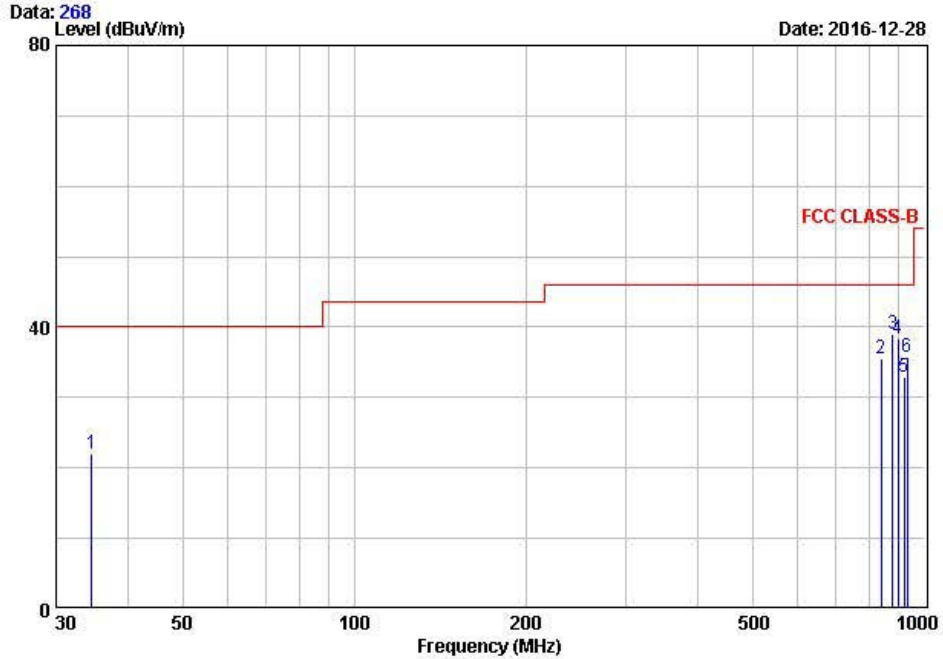

Peak	Freq MHz	Reading dBuV	C.F dB	Result dBuV/m	Limit QP dBuV/m	Margin dB	Height cm	Angle deg	Polarity
1	34.65	40.80	-18.72	22.08	40.00	17.92	100	54	VERTICAL
2	840.10	35.60	-0.13	35.47	46.00	10.53	317	98	HORIZONTAL
3	880.60	38.40	0.68	39.08	46.00	6.92	211	78	HORIZONTAL
4	900.10	37.40	1.07	38.47	46.00	7.53	315	147	HORIZONTAL
5	922.60	31.40	1.52	32.92	46.00	13.08	157	41	HORIZONTAL
6	933.60	34.10	1.73	35.83	46.00	10.17	148	11	HORIZONTAL

Remarks: C.F (Correction Factor) = Antenna factor + Cable loss - Preamp gain

5-1 Radiated Disturbance Measurements (Below 1GHz)_ Bluetooth(MID) Mode



4, Songju-ro 236 Beon-gil, Yanggi-myeon,
Cheoin-gu, Youngin-si, Gyeonggi-do,
449-822 Korea
Tel : +82-31-3236008,9
Fax : +82-31-3236010

EUT/Model No. : CDL-3PBR

TEST MODE: BLE Middle mode

Temp Humi : 0 / 50

Tested by: BANG Y H

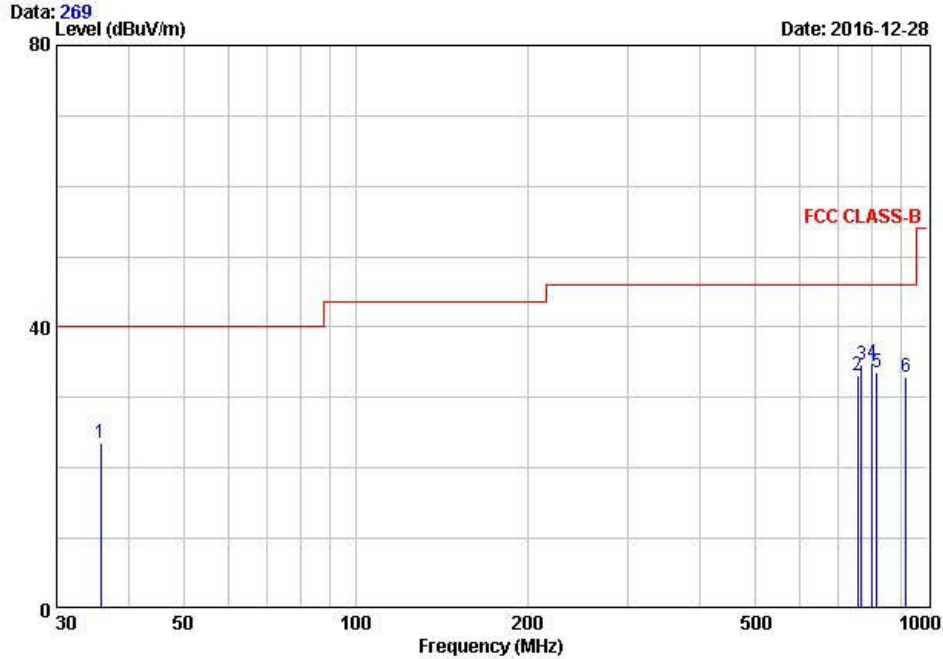

1	2	3	4	5	6			
Freq	Reading	C.F	Result	Limit	Margin	Height	Angle	Polarity
MHz	dBuV	dB	dBuV/m	QP	dB	cm	deg	
1	35.80	-18.59	23.51	40.00	16.49	100	85	VERTICAL
2	755.10	-1.65	33.15	46.00	12.85	218	48	HORIZONTAL
3	767.80	-1.43	34.67	46.00	11.33	318	55	HORIZONTAL
4	801.40	-0.86	34.94	46.00	11.06	248	21	HORIZONTAL
5	816.40	-0.57	33.63	46.00	12.37	358	48	HORIZONTAL
6	919.60	1.46	32.96	46.00	13.04	252	11	HORIZONTAL

Remarks: C.F (Correction Factor) = Antenna factor + Cable loss - Preamp gain

5-1 Radiated Disturbance Measurements (Below 1GHz)_ Bluetooth(HIGH) Mode



4, Songiro236Beon-gil, Yangji-myeon,
Cheoin-gu, Youngin-si, Gyeonggi-do,
449-822 Korea
Tel :+82-31-3236008,9
Fax:+82-31-3236010

EUT/Model No.: CDL-3PBR TEST MODE: BLE high mode
Temp Humi : 0 / 50 Tested by: BANG Y H

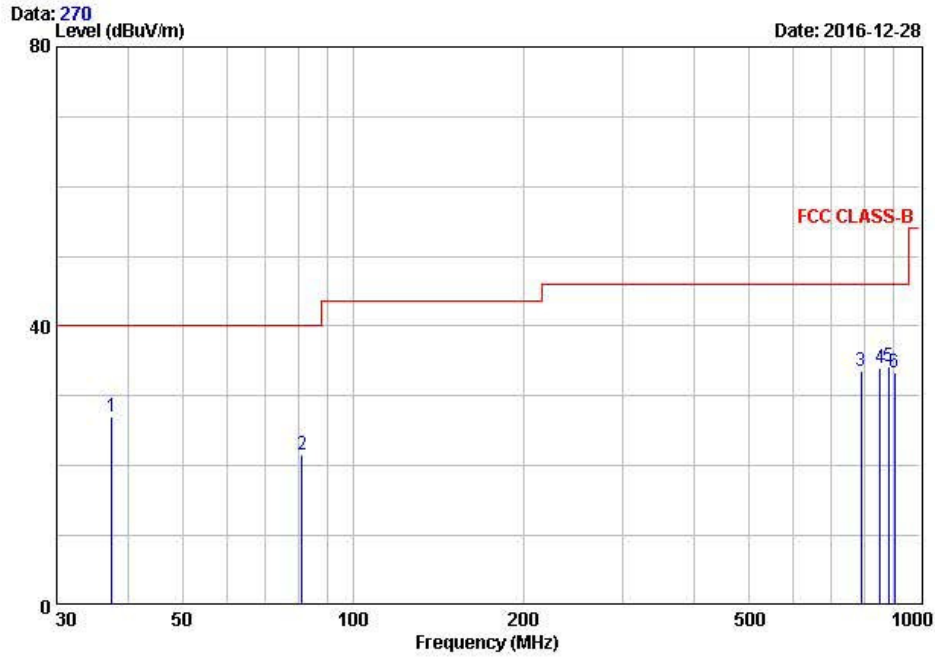

Freq	Reading	C.F	Result	Limit	Margin	Height	Angle	Polarity
MHz	dBuV	dB	dBuV/m	dBuV/m	dB	cm	deg	
1	37.50	45.40	-18.39	27.01	40.00	12.99	100	152 VERTICAL
2	81.40	42.90	-21.36	21.54	40.00	18.46	100	111 VERTICAL
3	788.40	34.60	-1.08	33.52	46.00	12.48	100	12 VERTICAL
4	852.10	33.80	0.10	33.90	46.00	12.10	218	48 HORIZONTAL
5	881.60	33.60	0.70	34.30	46.00	11.70	315	174 HORIZONTAL
6	905.40	32.20	1.18	33.38	46.00	12.62	400	84 HORIZONTAL

Remarks: C.F (Correction Factor) = Antenna factor + Cable loss - Preamp gain

5-1 Radiated Disturbance Measurements (Below 1GHz)_ RFID Mode



4, Songjuro236Beon-gil, Yangji-myeon,
Cheoin-gu, Youngin-si, Gyeonggi-do,
449-822 Korea
Tel :+82-31-3236008,9
Fax:+82-31-3236010

EUT/Model No.: CDL-3PBR TEST MODE: RFID mode
Temp Humi : 0 / 50 Tested by: BANG Y H

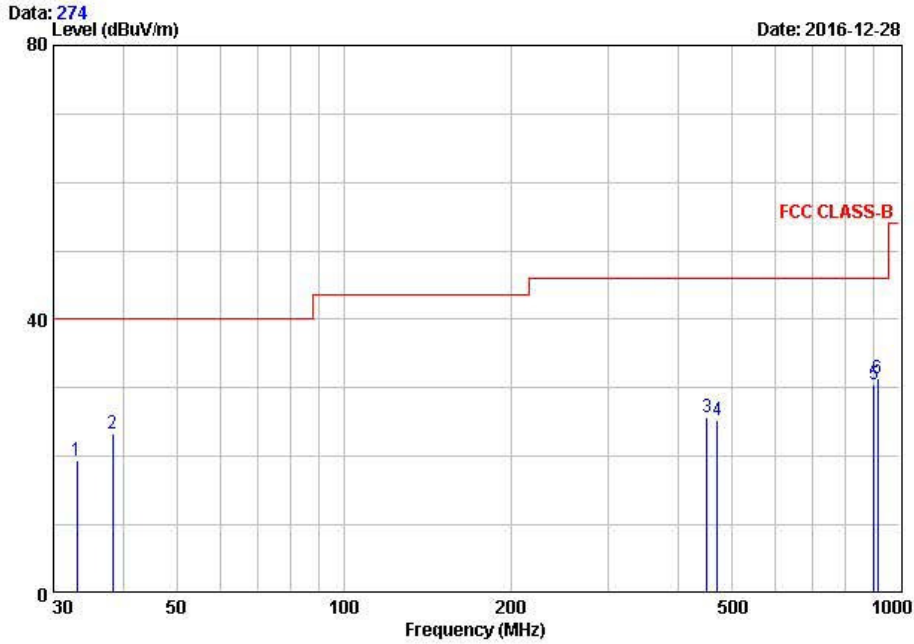

Peak No.	Freq (MHz)	Reading (dBuV)	C.F (dB)	Result (dBuV/m)	Limit QP (dBuV/m)	Margin (dB)	Height (cm)	Angle (deg)	Polarity
1	33.10	38.20	-18.85	19.35	40.00	20.65	100	85	VERTICAL
2	38.40	41.60	-18.29	23.31	40.00	16.69	100	62	VERTICAL
3	451.10	35.20	-9.40	25.80	46.00	20.20	100	58	VERTICAL
4	471.40	34.30	-9.06	25.24	46.00	20.76	100	62	VERTICAL
5	900.50	29.40	1.08	30.48	46.00	15.52	218	48	HORIZONTAL
6	916.50	30.10	1.40	31.50	46.00	14.50	311	5	HORIZONTAL

Remarks: C.F (Correction Factor) = Antenna factor + Cable loss - Preamp gain

(Above 1GHz)_ Bluetooth(LOW) Mode

EUT/Model No.: CDL-3PBR

 Tested by : BANG Y H

 Test Mode: BLE LOW mode

 Temp/Humi: 19 / 43

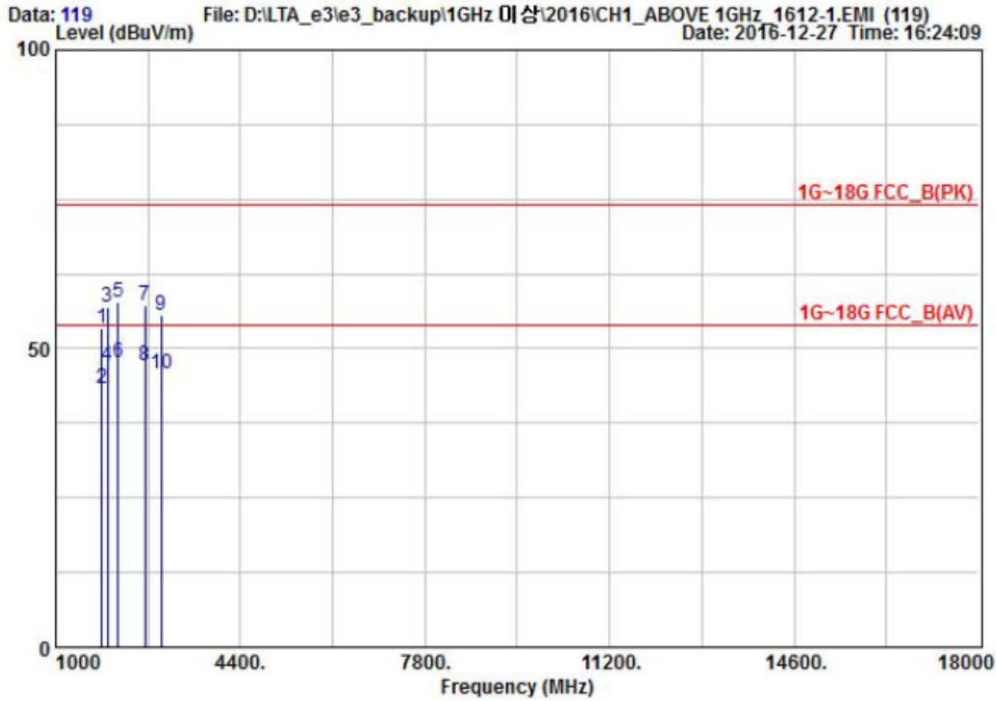

EUT/Model No.: CDL-3PBR

 Tested by : BANG Y H

 Test Mode: BLE LOW mode

 Temp/Humi: 19 / 43

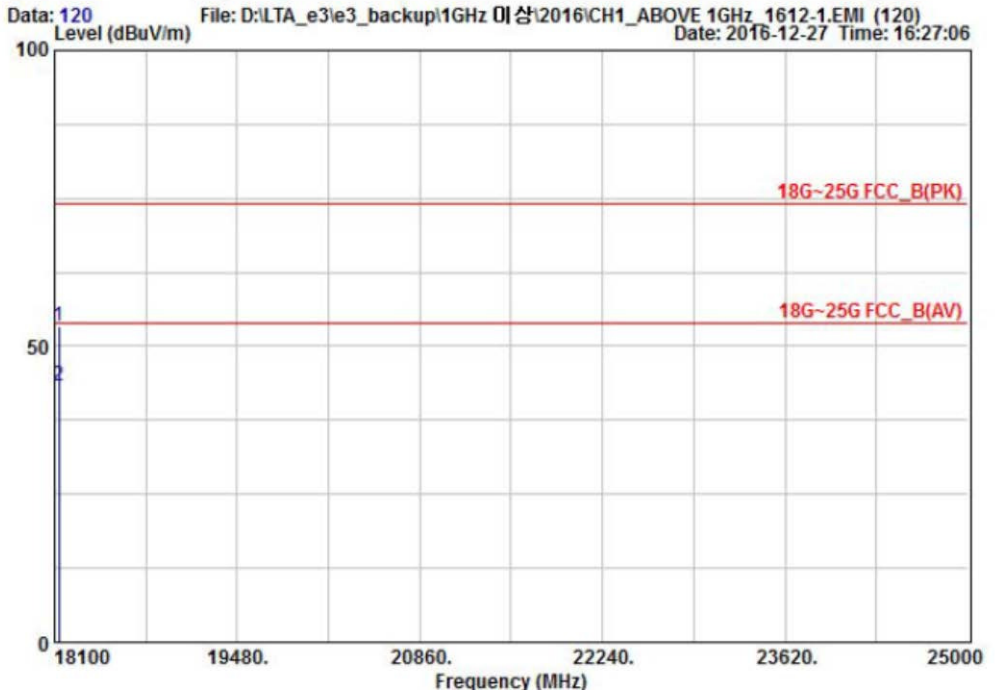

Manufacturer: COMMAX Co.,Ltd
Test Date
Temp.:
 [°C]

Humidity:
 [%]

Barometric [mbar]

2016/12/27

19

43

Model : CDL-3PBR
TEST mode : BLE LOW mode

Freq.(MHz)	Reading(PK) dBuV	Reading(AV) dBuV	C.F dB	Result(PK) dBuV/m	Result(AV) dBuV/m	Limit(PK) dBuV/m	Limit(AV) dBuV/m	Margin(PK) dB	Margin(AV) dB	Height cm	Angle deg	Polarity Hor/Ver
1847.7	50.1	40.1	3.36	53.46	43.46	74.0	54.0	20.54	10.54	100	151	V
1954.7	51.4	41.4	5.65	57.05	47.05			16.95	6.95	100	96	V
2146.1	51.2	41.2	6.44	57.64	47.64			16.36	6.36	100	111	V
2649.0	50.1	40.1	7.04	57.14	47.14			16.86	6.86	100	187	V
2944.7	46.6	36.6	9.1	55.70	45.70			18.30	8.30	100	133	V
18133.6	40.2	30.2	13.13	53.33	43.33			20.67	10.67	100	166	H

 ST EQUIPMENT USED: 01, 04, 05, 06, 07, 10, 11, 25

Manufacturer: COMMAX Co.,Ltd Model : CDL-3PBR TEST mode : BLE MIDDLE mode	Test Date 2016/12/27	Temp.: [°C]	Humidity: [%]	Barometric [mbar]
		19	43	

Freq.(MHz)	Reading(PK)	Reading(AV)	C.F	Result(PK)	Result(AV)	Limit(PK)	Limit(AV)	Margin(PK)	Margin(AV)	Height	Angle	Polarity
MHz	dBuV	dBuV	dB	dBuV/m	dBuV/m	dBuV/m	dBuV/m	dB	dB	cm	deg	Hor/Ver
4845.0	40.1	30.1	16.14	56.24	46.24	74.0	54.0	17.76	7.76	100	11	H
5011.7	41.1	31.1	16.66	57.76	47.76			16.24	6.24	100	189	H
5141.3	40.5	30.5	17.21	57.71	47.71			16.29	6.29	100	151	V
5524.7	39.6	29.6	17.64	57.24	47.24			16.76	6.76	100	151	V
5344.1	38.4	28.4	18.06	56.46	46.46			17.54	7.54	100	111	V
18111.4	41.5	31.5	13.11	54.61	44.61			19.39	9.39	100	188	H

 ST EQUIPMENT USED: 01, 04, 05, 06, 07, 10, 11, 25

(Above 1GHz)_ Bluetooth(HIGH) Mode

EUT/Model No.: CDL-3PBR Test Mode: BLE HIGH mode
 Tested by : BANG Y H Temp/Humi: 19 / 43

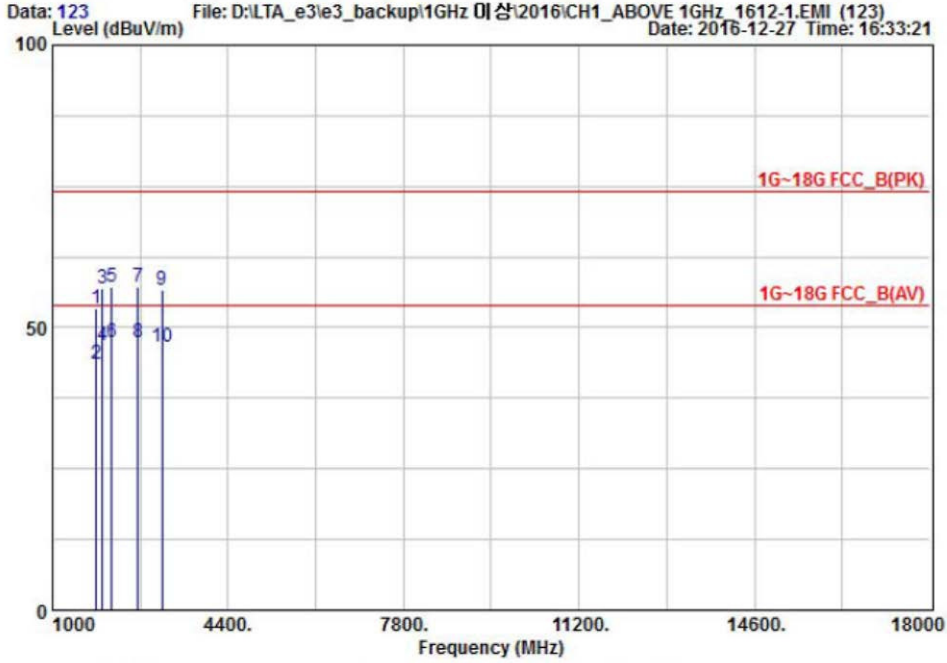

EUT/Model No.: CDL-3PBR Test Mode: BLE HIGH mode
 Tested by : BANG Y H Temp/Humi: 19 / 43

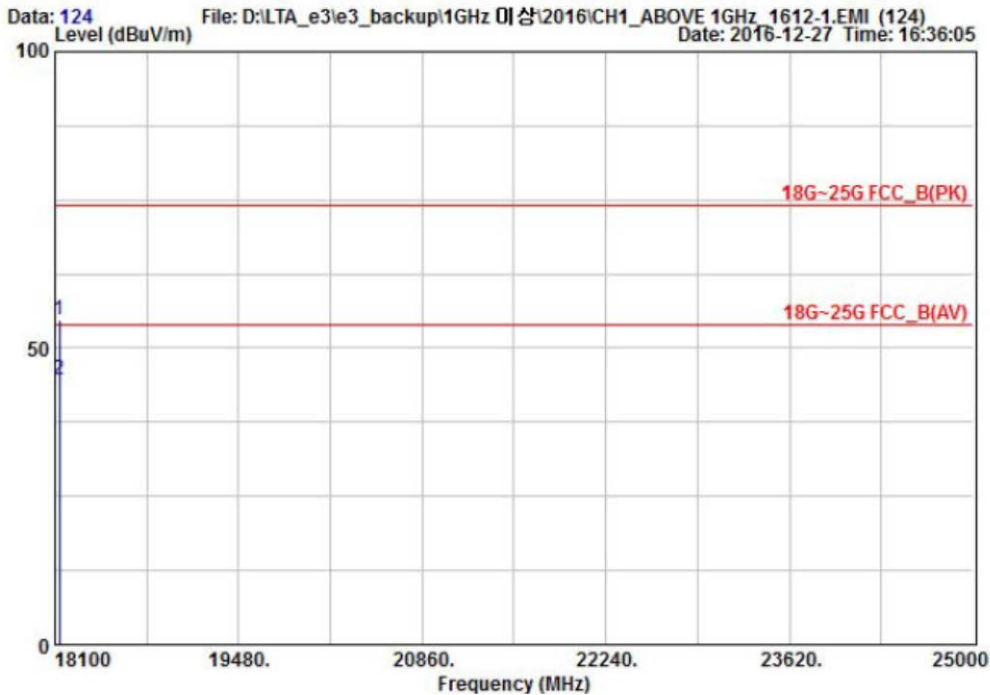

Manufacturer: COMMAX Co.,Ltd
Model : CDL-3PBR
TEST mode : BLE MIDDLE mode

Test Date 2016/12/27
Temp.: [°C] 19
Humidity: [%] 43
Barometric [mbar]

Freq.(MHz)	Reading(PK)	Reading(AV)	C.F	Result(PK)	Result(AV)	Limit(PK)	Limit(AV)	Margin(PK)	Margin(AV)	Height	Angle	Polarity
MHz	dBuV	dBuV	dB	dBuV/m	dBuV/m	dBuV/m	dBuV/m	dB	dB	cm	deg	Hor/Ver
1849.7	50.1	40.1	3.4	53.50	43.50	74.0	54.0	20.50	10.50	100	199	V
1964.1	51.1	41.1	5.85	56.95	46.95			17.05	7.05	100	15	V
2164.5	50.9	40.9	6.44	57.34	47.34			16.66	6.66	100	13	V
2661.8	50.2	40.2	7.13	57.33	47.33			16.67	6.67	100	133	V
3114.7	46.6	36.6	9.96	56.56	46.56			17.44	7.44	100	199	V
18136.5	41.6	31.6	13.13	54.73	44.73			19.27	9.27	100	88	H

ST EQUIPMENT USED: 01, 04, 05, 06, 07, 10, 11, 25

Conclusions

Product models "CDL-3PBR" meets all of the Class B requirements of the FCC Part 15, Subpart B. Limits of radio disturbance characteristics of ITE).

(Refer to Test Specification and Test Results in the "LTA certification", page3 and 4.)

- Bluetooth/Operating/Zigbee/RFID Mode: The highest internal source of an EUT is less than 108 MHz, the measurement shall only be made up to 1 GHz.(The highest internal source of an EUT : less than 108 MHz)