

EMC Test Report

Application for Grant of Equipment Authorization

*Industry Canada RSS-Gen Issue 3 / RSS 210 Issue 8
FCC Part 15 Subpart C*

Model: Sesam 800 L99

IC CERTIFICATION #: 1339A-L999
FCC ID: CBF-L999

APPLICANT: Control Chief Corporation
200 Williams Street, P.O. Box 141
Bradford, PA 16701

TEST SITE(S): Elliott Laboratories
41039 Boyce Road.
Fremont, CA. 94538-2435

IC SITE REGISTRATION #: 2845B-3, 2845B-5, 2845B-7

REPORT DATE: January 5, 2012

RE-ISSUED: January 31, 2012

FINAL TEST DATES: November 21 and December 7, 2011

TOTAL NUMBER OF PAGES: 32

PROGRAM MGR /
TECHNICAL REVIEWER:

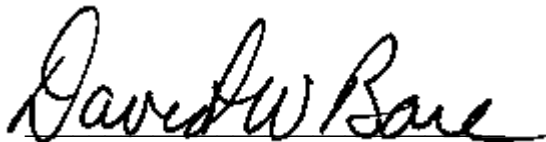

David W. Bare
Chief Engineer

QUALITY ASSURANCE DELEGATE /
FINAL REPORT PREPARER:

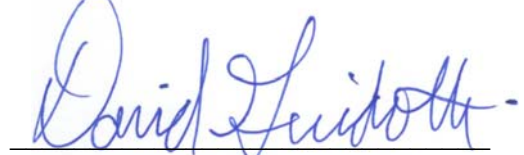

David Guidotti
Senior Technical Writer



Elliott Laboratories is accredited by the A2LA, certificate number 0214.26, to perform the test(s) listed in this report, except where noted otherwise. This report and the information contained herein represent the results of testing test articles identified and selected by the client performed to specifications and/or procedures selected by the client. National Technical Systems (NTS) makes no representations, expressed or implied, that such testing is adequate (or inadequate) to demonstrate efficiency, performance, reliability, or any other characteristic of the articles being tested, or similar products. This report should not be relied upon as an endorsement or certification by NTS of the equipment tested, nor does it represent any statement whatsoever as to its merchantability or fitness of the test article, or similar products, for a particular purpose. This report shall not be reproduced except in full

REVISION HISTORY

Rev#	Date	Comments	Modified By
-	1-5-2012	First release	
2	1-31-2012	Modified results summary highest field strength	dwb

TABLE OF CONTENTS

REVISION HISTORY	2
TABLE OF CONTENTS	3
SCOPE.....	4
OBJECTIVE	5
STATEMENT OF COMPLIANCE.....	5
DEVIATIONS FROM THE STANDARDS.....	5
TEST RESULTS SUMMARY - SESAM 800 L99.....	6
DEVICES OPERATING IN THE 902 – 928 / 2400 – 2483.5 / 5725 – 5850 MHZ BANDS	6
GENERAL REQUIREMENTS APPLICABLE TO ALL BANDS.....	6
MEASUREMENT UNCERTAINTIES.....	6
EQUIPMENT UNDER TEST (EUT) DETAILS.....	7
GENERAL.....	7
ANTENNA SYSTEM	7
ENCLOSURE.....	7
MODIFICATIONS.....	7
SUPPORT EQUIPMENT	7
EUT INTERFACE PORTS	7
EUT OPERATION	7
TEST SITE.....	8
GENERAL INFORMATION.....	8
CONDUCTED EMISSIONS CONSIDERATIONS	8
RADIATED EMISSIONS CONSIDERATIONS	8
MEASUREMENT INSTRUMENTATION	9
RECEIVER SYSTEM	9
INSTRUMENT CONTROL COMPUTER	9
LINE IMPEDANCE STABILIZATION NETWORK (LISN).....	9
FILTERS/ATTENUATORS	10
ANTENNAS.....	10
ANTENNA MAST AND EQUIPMENT TURNTABLE	10
INSTRUMENT CALIBRATION.....	10
TEST PROCEDURES	11
EUT AND CABLE PLACEMENT	11
CONDUCTED EMISSIONS.....	11
RADIATED EMISSIONS.....	11
RADIATED EMISSIONS.....	12
BANDWIDTH MEASUREMENTS	14
SPECIFICATION LIMITS AND SAMPLE CALCULATIONS	15
CONDUCTED EMISSIONS SPECIFICATION LIMITS: FCC 15.207; FCC 15.107(A), RSS GEN	15
GENERAL TRANSMITTER RADIATED EMISSIONS SPECIFICATION LIMITS	16
RECEIVER RADIATED SPURIOUS EMISSIONS SPECIFICATION LIMITS.....	16
RADIATED FUNDAMENTAL & SPURIOUS EMISSIONS SPECIFICATION LIMITS – 15.249 AND RSS 210 A2.9	17
SAMPLE CALCULATIONS - CONDUCTED EMISSIONS	17
SAMPLE CALCULATIONS - RADIATED EMISSIONS.....	17
SAMPLE CALCULATIONS - FIELD STRENGTH TO EIRP CONVERSION.....	18
APPENDIX A TEST EQUIPMENT CALIBRATION DATA	19
APPENDIX B TEST DATA	20
END OF REPORT	32

SCOPE

An electromagnetic emissions test has been performed on the Control Chief Corporation model Sesam 800 L99, pursuant to the following rules:

Industry Canada RSS-Gen Issue 3

RSS 210 Issue 8 "Low-power Licence-exempt Radiocommunication Devices (All Frequency Bands): Category I Equipment"

FCC Part 15 Subpart C

Conducted and radiated emissions data has been collected, reduced, and analyzed within this report in accordance with measurement guidelines set forth in the following reference standards and as outlined in Elliott Laboratories test procedures:

ANSI C63.4:2003

The intentional radiator above has been tested in a simulated typical installation to demonstrate compliance with the relevant Industry Canada performance and procedural standards.

Final system data was gathered in a mode that tended to maximize emissions by varying orientation of EUT, orientation of power and I/O cabling, antenna search height, and antenna polarization.

Every practical effort was made to perform an impartial test using appropriate test equipment of known calibration. All pertinent factors have been applied to reach the determination of compliance.

OBJECTIVE

The primary objective of the manufacturer is compliance with the regulations outlined in the previous section.

Prior to marketing in the USA, all unlicensed transmitters and transceivers require certification. Receive-only devices operating between 30 MHz and 960 MHz are subject to either certification or a manufacturer's declaration of conformity, with all other receive-only devices exempt from the technical requirements.

Prior to marketing in Canada, Class I transmitters, receivers and transceivers require certification. Class II devices are required to meet the appropriate technical requirements but are exempt from certification requirements.

Certification is a procedure where the manufacturer submits test data and technical information to a certification body and receives a certificate or grant of equipment authorization upon successful completion of the certification body's review of the submitted documents. Once the equipment authorization has been obtained, the label indicating compliance must be attached to all identical units, which are subsequently manufactured.

Maintenance of compliance is the responsibility of the manufacturer. Any modification of the product which may result in increased emissions should be checked to ensure compliance has been maintained (i.e., printed circuit board layout changes, different line filter, different power supply, harnessing or I/O cable changes, etc.).

STATEMENT OF COMPLIANCE

The tested sample of Control Chief Corporation model Sesam 800 L99 complied with the requirements of the following regulations:

- Industry Canada RSS-Gen Issue 3
- RSS 210 Issue 8 "Low-power Licence-exempt Radiocommunication Devices (All Frequency Bands): Category I Equipment"
- FCC Part 15 Subpart C

Maintenance of compliance is the responsibility of the manufacturer. Any modifications to the product should be assessed to determine their potential impact on the compliance status of the device with respect to the standards detailed in this test report.

The test results recorded herein are based on a single type test of Control Chief Corporation model Sesam 800 L99 and therefore apply only to the tested sample. The sample was selected and prepared by Jake Bryner of Control Chief Corporation.

DEVIATIONS FROM THE STANDARDS

No deviations were made from the published requirements listed in the scope of this report.

TEST RESULTS SUMMARY - Sesam 800 L99**DEVICES OPERATING IN THE 902 – 928 / 2400 – 2483.5 / 5725 – 5850 MHz BANDS**

FCC Rule Part	RSS Rule Part	Description	Measured Value / Comments	Limit / Requirement	Result
15.249 (a)	RSS 210 A2.9 (1)	Fundamental Signal Strength	85.6 dB μ V/m @ 926.5MHz (Margin: -8.4dB) ¹	50mV/m @ 3m	Complies
15.249 (a) / 15.209	RSS 210 A2.9 (1) & Table 2	Radiated Spurious Emissions, 30 - 9300 MHz	52.5dB μ V/m @ 2779.52MHz (Margin: -1.5dB)	Harmonics 500uV/m @ 3m or general limits (see page 16)	Complies

GENERAL REQUIREMENTS APPLICABLE TO ALL BANDS

FCC Rule Part	RSS Rule part	Description	Measured Value / Comments	Limit / Requirement	Result (margin)
15.203	-	RF Connector	Integral antenna	Unique or integral antenna required	Complies
15.207	RSS GEN Table 2	AC Conducted Emissions	27.5dB μ V @ 0.183MHz (-36.9dB)	Refer to page 15	Complies
15.109	RSS GEN 7.2.3 Table 1	Receiver spurious emissions	19.8dB μ V/m @ 30.00MHz (-20.2dB)	Refer to page 16	Complies
15.247 (b) (5) 15.407 (f)	RSS 102	RF Exposure Requirements	Refer to RSS 102 declaration	RSS 102	Complies
-	RSP 100 RSS GEN 7.1.5	User Manual		Statement required regarding non-interference	Complies
-	RSP 100 RSS GEN 7.1.5	User Manual		Statement for products with detachable antenna	Complies
-	RSP 100 RSS GEN 4.4.1	99% Bandwidth	240 Hz	Information only	N/A

MEASUREMENT UNCERTAINTIES

ISO/IEC 17025 requires that an estimate of the measurement uncertainties associated with the emissions test results be included in the report. The measurement uncertainties given below are based on a 95% confidence level and were calculated in accordance with UKAS document LAB 34.

Measurement Type	Measurement Unit	Frequency Range	Expanded Uncertainty
Radiated emission (field strength)	dB μ V/m	25 to 1000 MHz	\pm 3.6 dB
		1000 to 40000 MHz	\pm 6.0 dB
Conducted Emissions (AC Power)	dB μ V	0.15 to 30 MHz	\pm 2.4 dB

¹ Field strength for worst case orientation with final power setting.

EQUIPMENT UNDER TEST (EUT) DETAILS**GENERAL**

The Control Chief Corporation model Sesam 800 is a wireless, door opening system, consisting of a hand held controller (Sesam 800 L99) & receiver (Sesam 800 RXD) with relay outputs. Both units are transceivers. Since the controller is hand held and the receiver is fixed mounted during operation, the EUT was treated as table-top equipment during testing to simulate the end-user environment. The electrical rating of the controller is 3 VDC, 30 mA and of the receiver relay unit is 120V, 30 mA.

The samples were received on November 19, 2011 and tested on November 21 and December 7, 2011. The system consists of the following units:

Company	Model	Description	Serial Number	FCC ID
Akerstroms	Sesam 800 L99	Hand held Transceiver	-	CBF-L999
Akerstroms	Sesam 800 RXD	Stationary transceiver relay	1	CBF-800R

ANTENNA SYSTEM

The antenna is integral to the device.

ENCLOSURE

The RXD enclosure is primarily constructed of plastic. It measures approximately 12 cm wide by 9 cm deep by 5 cm high.

The L99 enclosure is primarily constructed of plastic. It measures approximately 7 cm wide by 12 cm deep by 3 cm high.

MODIFICATIONS

No modifications were made to the EUT during the time the product was at Elliott.

SUPPORT EQUIPMENT

No support equipment was used during testing.

EUT INTERFACE PORTS

The I/O cabling configuration during testing was as follows:

Port	Connected To	Description	Cable(s)	
			Shielded or Unshielded	Length(m)
AC Power (800 RXD)	AC Mains	2 wire	Unshielded	2

EUT OPERATION

During emissions testing the EUT was continuously transmitting a CW signal at 926.5 MHz, or in continuous receive mode tuned to 926.5 MHz.

TEST SITE**GENERAL INFORMATION**

Final test measurements were taken at the test sites listed below. Pursuant to section 2.948 of the FCC's Rules and section 3.3 of RSP-100, construction, calibration, and equipment data has been filed with the Commission and with industry Canada.

Site	Registration Numbers		Location
	FCC	Canada	
Chamber 3	769238	2845B-3	41039 Boyce Road Fremont, CA 94538-2435
Chamber 5	211948	2845B-5	
Chamber 7	A2LA accreditation	2845B-7	

ANSI C63.4:2003 recommends that ambient noise at the test site be at least 6 dB below the allowable limits. Ambient levels are below this requirement. The test site(s) contain separate areas for radiated and conducted emissions testing. Considerable engineering effort has been expended to ensure that the facilities conform to all pertinent requirements of ANSI C63.4:2003.

CONDUCTED EMISSIONS CONSIDERATIONS

Conducted emissions testing is performed in conformance with ANSI C63.4:2003. Measurements are made with the EUT connected to the public power network through a nominal, standardized RF impedance, which is provided by a line impedance stabilization network, known as a LISN. A LISN is inserted in series with each current-carrying conductor in the EUT power cord.

RADIATED EMISSIONS CONSIDERATIONS

The FCC has determined that radiation measurements made in a shielded enclosure are not suitable for determining levels of radiated emissions. Radiated measurements are performed in an open field environment or in a semi-anechoic chamber. The test sites are maintained free of conductive objects within the CISPR defined elliptical area incorporated in ANSI C63.4:2003 guidelines and meet the Normalized Site Attenuation (NSA) requirements of ANSI C63.4:2003.

MEASUREMENT INSTRUMENTATION

RECEIVER SYSTEM

An EMI receiver as specified in CISPR 16-1-1 is used for emissions measurements. The receivers used can measure over the frequency range of 9 kHz up to 2000 MHz. These receivers allow both ease of measurement and high accuracy to be achieved. The receivers have Peak, Average, and CISPR (Quasi-peak) detectors built into their design so no external adapters are necessary. The receiver automatically sets the required bandwidth for the CISPR detector used during measurements. If the repetition frequency of the signal being measured is below 20Hz, peak measurements are made in lieu of Quasi-Peak measurements.

For measurements above the frequency range of the receivers, a spectrum analyzer is utilized because it provides visibility of the entire spectrum along with the precision and versatility required to support engineering analysis. Average measurements above 1000MHz are performed on the spectrum analyzer using the linear-average method with a resolution bandwidth of 1 MHz and a video bandwidth of 10 Hz, unless the signal is pulsed in which case the average (or video) bandwidth of the measuring instrument is reduced to onset of pulse desensitization and then increased.

INSTRUMENT CONTROL COMPUTER

The receivers utilize either a Rohde & Schwarz EZM Spectrum Monitor/Controller or contain an internal Spectrum Monitor/Controller to view and convert the receiver measurements to the field strength at an antenna or voltage developed at the LISN measurement port, which is then compared directly with the appropriate specification limit. This provides faster, more accurate readings by performing the conversions described under Sample Calculations within the Test Procedures section of this report. Results are printed in a graphic and/or tabular format, as appropriate. A personal computer is used to record all measurements made with the receivers.

The Spectrum Monitor provides a visual display of the signal being measured. In addition, the controller or a personal computer run automated data collection programs which control the receivers. This provides added accuracy since all site correction factors, such as cable loss and antenna factors are added automatically.

LINE IMPEDANCE STABILIZATION NETWORK (LISN)

Line conducted measurements utilize a fifty microhenry Line Impedance Stabilization Network as the monitoring point. The LISN used also contains a 250 uH CISPR adapter. This network provides for calibrated radio frequency noise measurements by the design of the internal low pass and high pass filters on the EUT and measurement ports, respectively.

FILTERS/ATTENUATORS

External filters and precision attenuators are often connected between the receiving antenna or LISN and the receiver. This eliminates saturation effects and non-linear operation due to high amplitude transient events.

ANTENNAS

A loop antenna is used below 30 MHz. For the measurement range 30 MHz to 1000 MHz either a combination of a biconical antenna and a log periodic or a bi-log antenna is used. Above 1000 MHz, horn antennas are used. The antenna calibration factors to convert the received voltage to an electric field strength are included with appropriate cable loss and amplifier gain factors to determine an overall site factor, which is then programmed into the test receivers or incorporated into the test software.

ANTENNA MAST AND EQUIPMENT TURNTABLE

The antennas used to measure the radiated electric field strength are mounted on a non-conductive antenna mast equipped with a motor-drive to vary the antenna height. Measurements below 30 MHz are made with the loop antenna at a fixed height of 1m above the ground plane.

ANSI C63.4:2003 specifies that the test height above ground for table mounted devices shall be 80 centimeters. Floor mounted equipment shall be placed on the ground plane if the device is normally used on a conductive floor or separated from the ground plane by insulating material from 3 to 12 mm if the device is normally used on a non-conductive floor. During radiated measurements, the EUT is positioned on a motorized turntable in conformance with this requirement.

INSTRUMENT CALIBRATION

All test equipment is regularly checked to ensure that performance is maintained in accordance with the manufacturer's specifications. All antennas are calibrated at regular intervals with respect to tuned half-wave dipoles. An exhibit of this report contains the list of test equipment used and calibration information.

TEST PROCEDURES

EUT AND CABLE PLACEMENT

The regulations require that interconnecting cables be connected to the available ports of the unit and that the placement of the unit and the attached cables simulate the worst case orientation that can be expected from a typical installation, so far as practicable. To this end, the position of the unit and associated cabling is varied within the guidelines of ANSI C63.4:2003, and the worst-case orientation is used for final measurements.

CONDUCTED EMISSIONS

Conducted emissions are measured at the plug end of the power cord supplied with the EUT. Excess power cord length is wrapped in a bundle between 30 and 40 centimeters in length near the center of the cord. Preliminary measurements are made to determine the highest amplitude emission relative to the specification limit for all the modes of operation. Placement of system components and varying of cable positions are performed in each mode. A final peak mode scan is then performed in the position and mode for which the highest emission was noted on all current carrying conductors of the power cord.

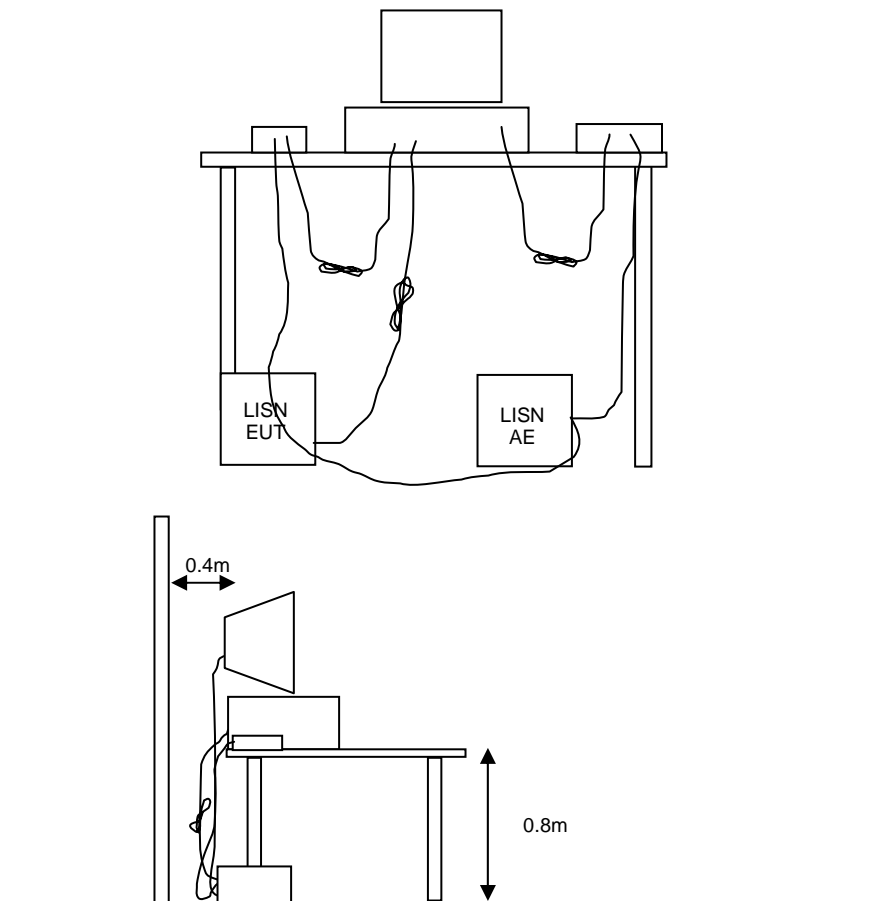

Figure 1 Typical Conducted Emissions Test Configuration

RADIATED EMISSIONS

A preliminary scan of the radiated emissions is performed in which all significant EUT frequencies are identified with the system in a nominal configuration. At least two scans are performed, one scan for each antenna polarization (horizontal and vertical; loop parallel and perpendicular to the EUT). During the preliminary scans, the EUT is rotated through 360°, the antenna height is varied (for measurements above 30 MHz) and cable positions are varied to determine the highest emission relative to the limit. Preliminary scans may be performed in a fully anechoic chamber for the purposes of identifying the frequencies of the highest emissions from the EUT.

A speaker is provided in the receiver to aid in discriminating between EUT and ambient emissions. Other methods used during the preliminary scan for EUT emissions involve scanning with near field magnetic loops, monitoring I/O cables with RF current clamps, and cycling power to the EUT.

Final maximization is a phase in which the highest amplitude emissions identified in the spectral search are viewed while the EUT azimuth angle is varied from 0 to 360 degrees relative to the receiving antenna. The azimuth, which results in the highest emission is then maintained while varying the antenna height from one to four meters (for measurements above 30 MHz, measurements below 30 MHz are made with the loop antenna at a fixed height of 1m). The result is the identification of the highest amplitude for each of the highest peaks. Each recorded level is corrected in the receiver using appropriate factors for cables, connectors, antennas, and preamplifier gain.

When testing above 18 GHz, the receive antenna is located at 1 meter from the EUT and the antenna height is restricted to a maximum of 2.5 meters.

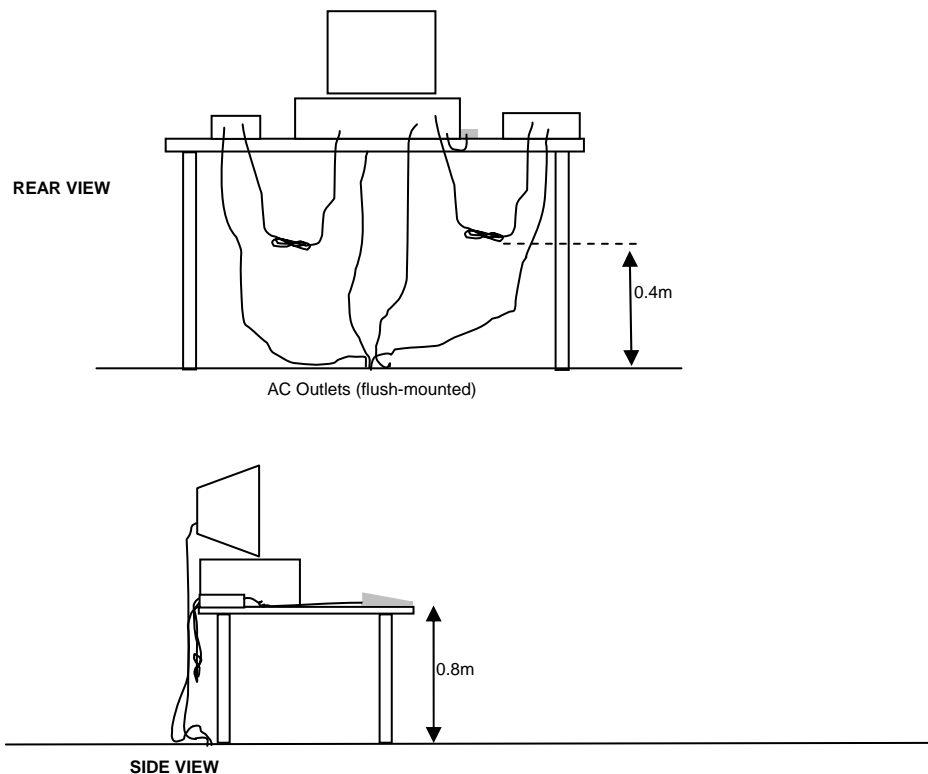

Typical Test Configuration for Radiated Field Strength Measurements

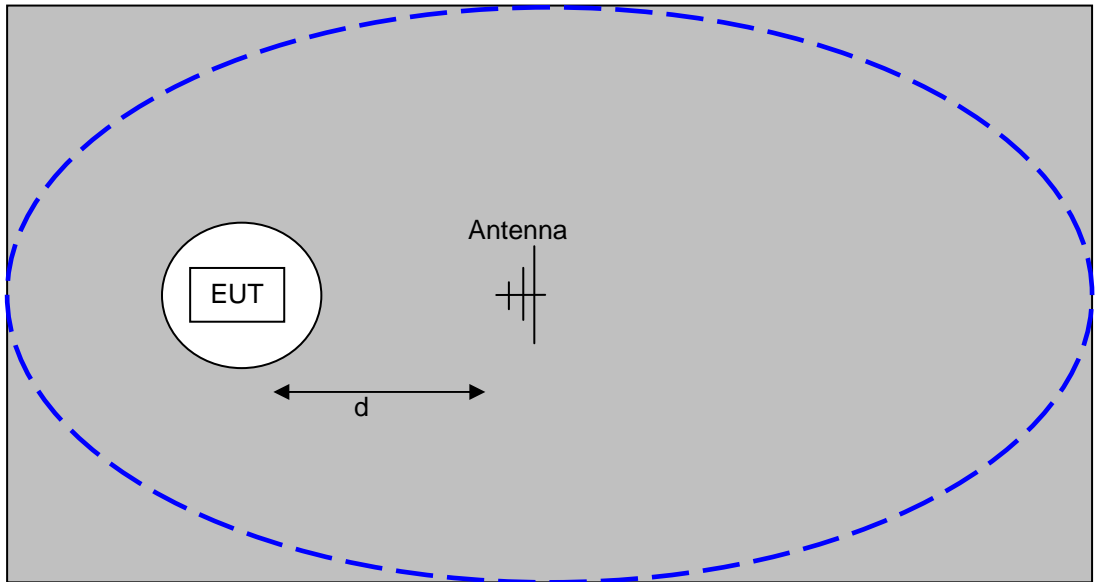

The ground plane extends beyond the ellipse defined in CISPR 16 / CISPR 22 / ANSI C63.4 and is large enough to accommodate test distances (d) of 3m and 10m. Refer to the test data tables for the actual measurement distance.

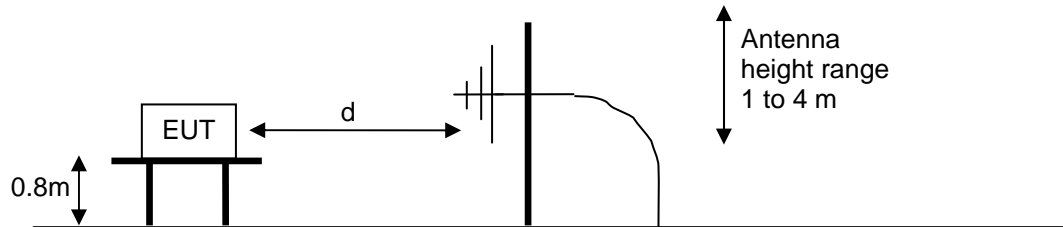

Test Configuration for Radiated Field Strength Measurements
OATS- Plan and Side Views

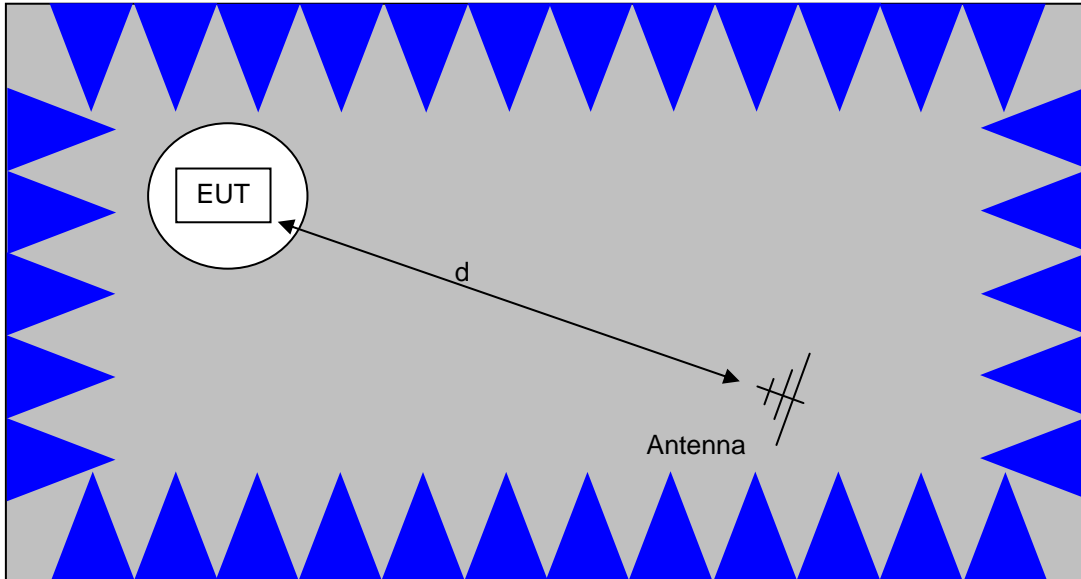

The anechoic materials on the walls and ceiling ensure compliance with the normalized site attenuation requirements of CISPR 16 / CISPR 22 / ANSI C63.4 for an alternate test site at the measurement distances used.

Floor-standing equipment is placed on the floor with insulating supports between the unit and the ground plane.

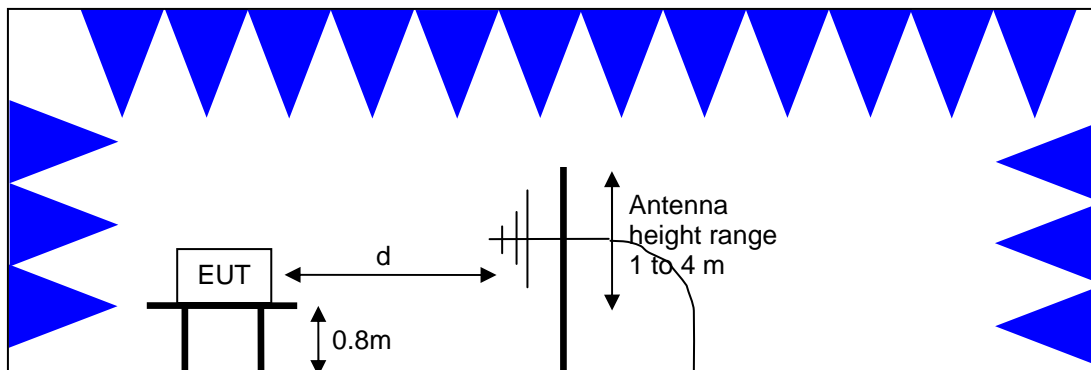

Test Configuration for Radiated Field Strength Measurements
Semi-Anechoic Chamber, Plan and Side Views

BANDWIDTH MEASUREMENTS

The 6dB, 20dB and/or 26dB signal bandwidth is measured in using the bandwidths recommended by ANSI C63.4. When required, the 99% bandwidth is measured using the methods detailed in RSS GEN.

SPECIFICATION LIMITS AND SAMPLE CALCULATIONS

The limits for conducted emissions are given in units of microvolts, and the limits for radiated emissions are given in units of microvolts per meter at a specified test distance. Data is measured in the logarithmic form of decibels relative to one microvolt, or dB microvolts (dBuV). For radiated emissions, the measured data is converted to the field strength at the antenna in dB microvolts per meter (dBuV/m). The results are then converted to the linear forms of uV and uV/m for comparison to published specifications.

For reference, converting the specification limits from linear to decibel form is accomplished by taking the base ten logarithm, then multiplying by 20. These limits in both linear and logarithmic form are as follows:

CONDUCTED EMISSIONS SPECIFICATION LIMITS: FCC 15.207; FCC 15.107(a), RSS GEN

The table below shows the limits for the emissions on the AC power line from an intentional radiator and a receiver.

Frequency (MHz)	Average Limit (dBuV)	Quasi Peak Limit (dBuV)
0.150 to 0.500	Linear decrease on logarithmic frequency axis between 56.0 and 46.0	Linear decrease on logarithmic frequency axis between 66.0 and 56.0
0.500 to 5.000	46.0	56.0
5.000 to 30.000	50.0	60.0

GENERAL TRANSMITTER RADIATED EMISSIONS SPECIFICATION LIMITS

The table below shows the limits for the spurious emissions from transmitters that fall in restricted bands² (with the exception of transmitters operating under FCC Part 15 Subpart D and RSS 210 Annex 9), the limits for all emissions from a low power device operating under the general rules of RSS 310 (tables 3 and 4), RSS 210 (table 2) and FCC Part 15 Subpart C section 15.209.

Frequency Range (MHz)	Limit (uV/m)	Limit (dBuV/m @ 3m)
0.009-0.490	2400/F _{KHz} @ 300m	67.6-20*log ₁₀ (F _{KHz}) @ 300m
0.490-1.705	24000/F _{KHz} @ 30m	87.6-20*log ₁₀ (F _{KHz}) @ 30m
1.705 to 30	30 @ 30m	29.5 @ 30m
30 to 88	100 @ 3m	40 @ 3m
88 to 216	150 @ 3m	43.5 @ 3m
216 to 960	200 @ 3m	46.0 @ 3m
Above 960	500 @ 3m	54.0 @ 3m

RECEIVER RADIATED SPURIOUS EMISSIONS SPECIFICATION LIMITS

The table below shows the limits for the spurious emissions from receivers as detailed in FCC Part 15.109, RSS 210 Table 2, RSS GEN Table 1 and RSS 310 Table 3. Note that receivers operating outside of the frequency range 30 MHz – 960 MHz are exempt from the requirements of 15.109.

Frequency Range (MHz)	Limit (uV/m @ 3m)	Limit (dBuV/m @ 3m)
30 to 88	100	40
88 to 216	150	43.5
216 to 960	200	46.0
Above 960	500	54.0

² The restricted bands are detailed in FCC 15.203, RSS 210 Table 1 and RSS 310 Table 2

RADIATED FUNDAMENTAL & SPURIOUS EMISSIONS SPECIFICATION LIMITS – 15.249 and RSS 210 A2.9

The table below shows the limits for the fundamental emission and for its harmonics. Harmonics that fall in restricted bands³ and all other spurious emissions are subject to the general limits of RSS 210 and FCC Part 15 Subpart C.

Frequency Range (MHz)	Limit for Fundamental @ 3m	Limit for Harmonics @ 3m
902 – 928	50,000 uV/m 94dBuV/m	500 uV/m 54dBuV/m
2400 – 2483.5	50,000 uV/m 94dBuV/m	500 uV/m 54dBuV/m
5725 - 5850	50,000 uV/m 94dBuV/m	500 uV/m 54dBuV/m

SAMPLE CALCULATIONS - CONDUCTED EMISSIONS

Receiver readings are compared directly to the conducted emissions specification limit (decibel form) as follows:

$$R_r - S = M$$

where:

R_r = Receiver Reading in dBuV

S = Specification Limit in dBuV

M = Margin to Specification in +/- dB

SAMPLE CALCULATIONS - RADIATED EMISSIONS

Receiver readings are compared directly to the specification limit (decibel form). The receiver internally corrects for cable loss, preamplifier gain, and antenna factor. The calculations are in the reverse direction of the actual signal flow, thus cable loss is added and the amplifier gain is subtracted. The Antenna Factor converts the voltage at the antenna coaxial connector to the field strength at the antenna elements.

A distance factor, when used for electric field measurements above 30MHz, is calculated by using the following formula:

$$F_d = 20 * \text{LOG}_{10} (D_m/D_s)$$

where:

F_d = Distance Factor in dB

D_m = Measurement Distance in meters

D_s = Specification Distance in meters

³ The restricted bands are detailed in FCC 15.203, RSS 210 Table 1 and RSS 310 Table 2

For electric field measurements below 30MHz the extrapolation factor is either determined by making measurements at multiple distances or a theoretical value is calculated using the formula:

$$F_d = 40 * \text{LOG}_{10} (D_m/D_s)$$

Measurement Distance is the distance at which the measurements were taken and Specification Distance is the distance at which the specification limits are based. The antenna factor converts the voltage at the antenna coaxial connector to the field strength at the antenna elements.

The margin of a given emission peak relative to the limit is calculated as follows:

$$R_c = R_r + F_d$$

and

$$M = R_c - L_s$$

where:

$$R_r = \text{Receiver Reading in dBuV/m}$$

$$F_d = \text{Distance Factor in dB}$$

$$R_c = \text{Corrected Reading in dBuV/m}$$

$$L_s = \text{Specification Limit in dBuV/m}$$

$$M = \text{Margin in dB Relative to Spec}$$

SAMPLE CALCULATIONS - FIELD STRENGTH TO EIRP CONVERSION

Where the radiated electric field strength is expressed in terms of the equivalent isotropic radiated power (eirp), or where a field strength measurement of output power is made in lieu of a direct measurement, the following formula is used to convert between eirp and field strength at a distance of d (meters) from the equipment under test:

$$E = \frac{1000000 \sqrt{30 P}}{d} \quad \text{microvolts per meter}$$

where P is the eirp (Watts)

For a measurement at 3m the conversion from a logarithmic value for field strength (dBuV/m) to an eirp power (dBm) is -95.3dB.

Appendix A Test Equipment Calibration Data**Radiated Emissions, 30 - 10,000 MHz, 21-Nov-11**

<u>Manufacturer</u>	<u>Description</u>	<u>Model</u>	<u>Asset #</u>	<u>Cal Due</u>
Hewlett Packard	Microwave Preamplifier, 1-26.5GHz	8449B	785	5/18/2012
EMCO	Antenna, Horn, 1-18 GHz	3115	786	12/11/2011
Hewlett Packard	High Pass filter, 1.5 GHz (Blue System)	P/N 84300-80037 (84125C)	1389	5/4/2012
Hewlett Packard	SpecAn 9 kHz - 40 GHz, FT (SA40) Blue	8564E (84125C)	1393	8/9/2012
Rohde & Schwarz	EMI Test Receiver, 20 Hz-7 GHz	ESIB7	1630	4/13/2012
Sunol Sciences	Biconilog, 30-3000 MHz	JB3	2237	7/14/2012
Com-Power Corp.	Preamplifier, 30-1000 MHz	PAM-103	2380	4/13/2012

Radiated Emissions, 30 - 1,000 MHz, 07-Dec-11

<u>Manufacturer</u>	<u>Description</u>	<u>Model</u>	<u>Asset #</u>	<u>Cal Due</u>
Rohde & Schwarz	Test Receiver, 20-1300 MHz	ESVP	213	7/1/2012
Hewlett Packard	EMC Spectrum Analyzer, 9 kHz - 6.5 GHz	8595EM	787	7/29/2012
Hewlett Packard	Preamplifier, 100 kHz - 1.3 GHz	8447D OPT 010	1826	5/17/2012
Sunol Sciences	Biconilog, 30-3000 MHz	JB3	2197	12/29/2011

Appendix B Test Data

T85509 Pages 21 – 31



EMC Test Data

Client:	Control Chief	Job Number:	J85385
Model:	Sesam 800	T-Log Number:	T85509
		Account Manager:	Susan Pelzl
Contact:	Jake Byner		-
Emissions Standard(s):	FCC 15.249, RSS-210	Class:	-
Immunity Standard(s):	-	Environment:	-

EMC Test Data

For The

Control Chief

Model

Sesam 800

Date of Last Test: 12/9/2011

Client:	Control Chief	Job Number:	J85385
Model:	Sesam 800	T-Log Number:	T85509
Contact:	Jake Byner	Account Manager:	Susan Pelzl
Standard:	FCC 15.249, RSS-210	Class:	-

Radiated Emissions

(Elliott Laboratories Fremont Facility, Semi-Anechoic Chamber)

Test Specific Details

Objective: The objective of this test session is to perform final qualification testing of the EUT with respect to the specification listed above.

Date of Test: 11/21/11 and 12/7/11
 Test Engineer: V. Narayan, M. Birgani
 Test Location: Fremont Chamber #3

Config. Used: 1
 Config Change: None
 EUT Voltage: Battery

General Test Configuration

The EUT and any local support equipment were located on the turntable for radiated emissions testing.

The test distance and extrapolation factor (if applicable) are detailed under each run description.

Note, preliminary testing indicates that the emissions were maximized by orientation of the EUT and elevation of the measurement antenna. Maximized testing indicated that the emissions were maximized by orientation of the EUT, elevation of the measurement antenna, and manipulation of the EUT's interface cables.

Ambient Conditions:

Temperature: 20 °C
 Rel. Humidity: 41 %

Summary of Results

Run #	Test Performed	Limit	Result	Margin
1	Radiated Emissions 30 - 10,000 MHz	FCC 15.249	-	Refer to individual runs
2	Radiated Emissions 30 - 3,000 MHz	RSS 210	PASS	19.8dBμV/m @ 30.00MHz (Margin: -20.2dB)

Modifications Made During Testing

No modifications were made to the EUT during testing

Deviations From The Standard

No deviations were made from the requirements of the standard.

Client:	Control Chief	Job Number:	J85385
Model:	Sesam 800	T-Log Number:	T85509
Contact:	Jake Byner	Account Manager:	Susan Pelzl
Standard:	FCC 15.249, RSS-210	Class:	-

Run #1a: Radiated Emissions, 30 - 10,000 MHz (Sesam 800 L99 - transmit mode) FLAT

Frequency Range	Test Distance	Limit Distance	Extrapolation Factor
30 - 10,000 MHz	3	3	0.0

Fundamental Frequency

Frequency MHz	Level dB μ V/m	Pol v/h	FCC 15.249		Detector Pk/QP/Avg	Azimuth degrees	Height meters	Comments	Setting
			Limit	Margin					
926.404	85.6	H	94.0	-8.4	QP	318	1.0	QP (1.00s)	44
926.404	74.6	V	94.0	-19.4	QP	251	1.6	QP (1.00s)	44

Spurious emission

Frequency MHz	Level dB μ V/m	Pol v/h	FCC 15.249		Detector Pk/QP/Avg	Azimuth degrees	Height meters	Comments	Setting
			Limit	Margin					
30.000	24.4	H	40.0	-15.6	QP	141	3.0	QP (1.00s)	50
900.862	26.3	H	46.0	-19.7	QP	325	1.0	QP (1.00s)	50
928.000	26.7	H	46.0	-19.3	QP	141	3.0	QP (1.00s)	50
1852.980	45.5	V	54.0	-8.5	AVG	142	1.0	RB 1 MHz;VB 10 Hz;Pk	50
1854.060	53.8	V	74.0	-20.2	PK	142	1.0	RB 1 MHz;VB 3 MHz;Pk	50
2779.210	60.1	H	74.0	-13.9	PK	126	1.9	RB 1 MHz;VB 3 MHz;Pk	50
2779.480	52.1	H	54.0	-1.9	AVG	126	1.9	RB 1 MHz;VB 10 Hz;Pk	50
3705.640	48.1	H	74.0	-25.9	PK	211	1.9	RB 1 MHz;VB 3 MHz;Pk	50
3706.020	40.1	H	54.0	-13.9	AVG	211	1.9	RB 1 MHz;VB 10 Hz;Pk	50
4632.510	38.5	V	54.0	-15.5	AVG	16	1.3	RB 1 MHz;VB 10 Hz;Pk	50
4632.880	46.5	V	74.0	-27.5	PK	16	1.3	RB 1 MHz;VB 3 MHz;Pk	50
5557.990	50.0	V	74.0	-24.0	PK	283	1.0	RB 1 MHz;VB 3 MHz;Pk	50
5558.980	42.0	V	54.0	-12.0	AVG	283	1.0	RB 1 MHz;VB 10 Hz;Pk	50
7411.980	37.7	V	54.0	-16.3	AVG	99	1.9	RB 1 MHz;VB 10 Hz;Pk	50
7413.580	45.7	V	74.0	-28.3	PK	99	1.9	RB 1 MHz;VB 3 MHz;Pk	50

Note 1: The average values are calculated from the peak level less 8dB duty cycle correction factor (40% duty cycle)

Client:	Control Chief	Job Number:	J85385
Model:	Sesam 800	T-Log Number:	T85509
Contact:	Jake Byner	Account Manager:	Susan Pelzl
Standard:	FCC 15.249, RSS-210	Class:	-

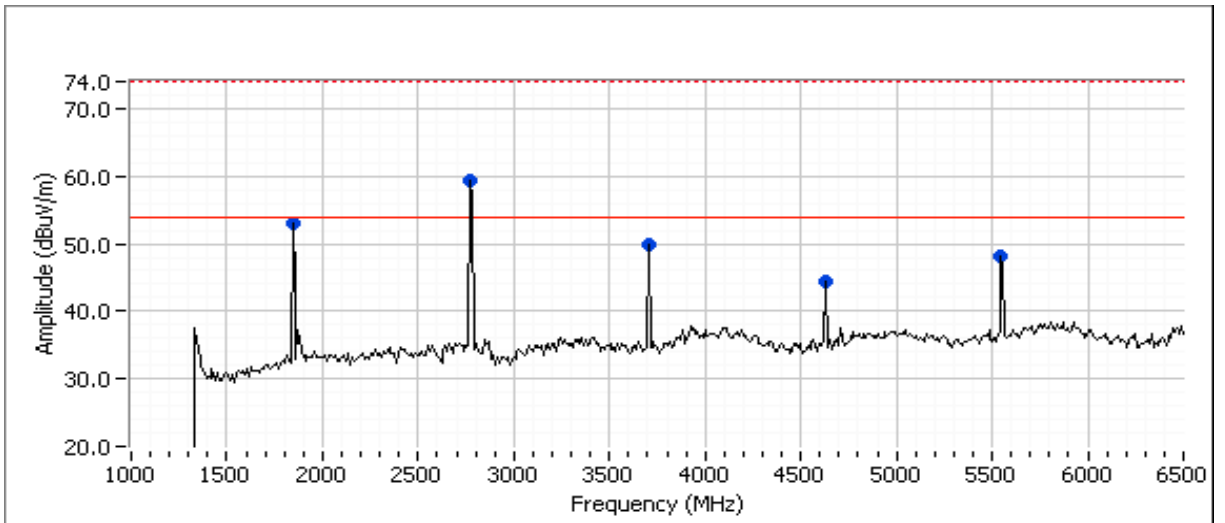
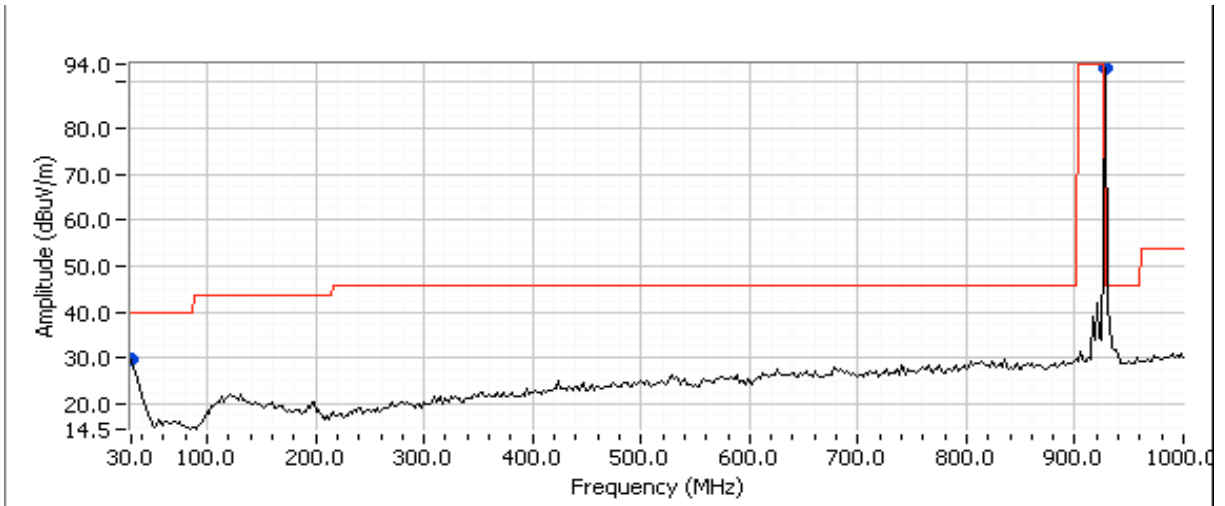

Client:	Control Chief	Job Number:	J85385
Model:	Sesam 800	T-Log Number:	T85509
Contact:	Jake Byner	Account Manager:	Susan Pelzl
Standard:	FCC 15.249, RSS-210	Class:	-

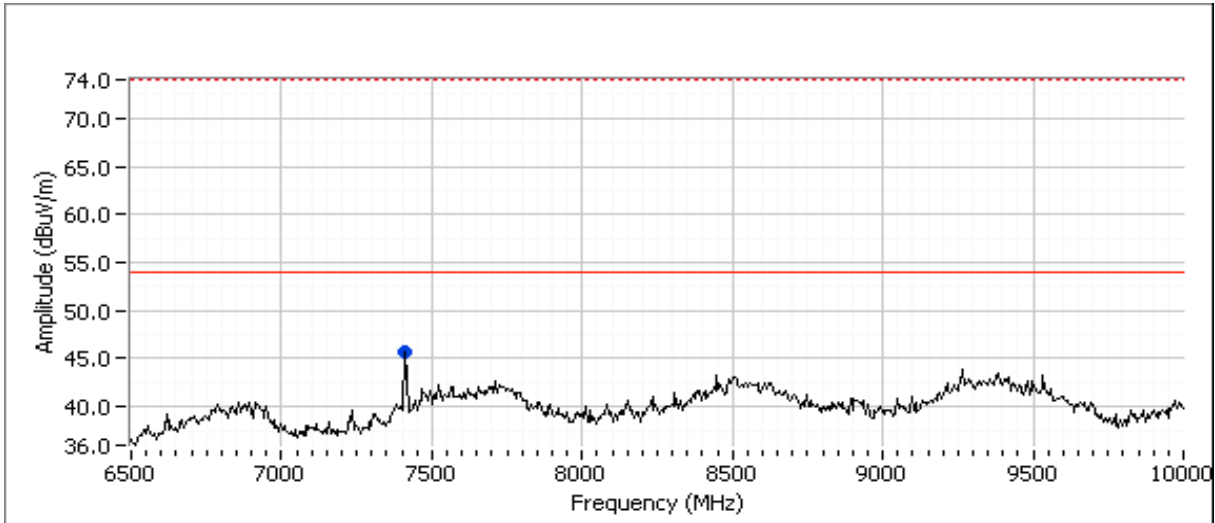

Client:	Control Chief	Job Number:	J85385
Model:	Sesam 800	T-Log Number:	T85509
Contact:	Jake Byner	Account Manager:	Susan Pelzl
Standard:	FCC 15.249, RSS-210	Class:	-

Run #1b: Radiated Emissions, 30 - 10,000 MHz (Sesam 800 L99 - transmit mode) SIDE

Fundamental Frequency

Frequency MHz	Level dB μ V/m	Pol v/h	FCC 15.249		Detector Pk/QP/Avg	Azimuth degrees	Height meters	Comments	
			Limit	Margin					Setting
926.404	84.8	V	94.0	-9.2	QP	318	1.0	QP (1.00s)	44
926.404	76.1	H	94.0	-17.9	QP	39	1.0	QP (1.00s)	44

Spurious emission

Frequency MHz	Level dB μ V/m	Pol v/h	FCC 15.249		Detector Pk/QP/Avg	Azimuth degrees	Height meters	Comments	
			Limit	Margin					Setting
902.000	26.3	H	46.0	-19.7	QP	320	3.5	QP (1.00s)	50
928.000	26.7	H	46.0	-19.3	QP	320	3.5	QP (1.00s)	50
1853.050	42.7	V	54.0	-11.3	AVG	144	1.0	RB 1 MHz;VB 10 Hz;Pk	50
1853.100	50.7	V	74.0	-23.3	PK	144	1.0	RB 1 MHz;VB 3 MHz;Pk	50
2778.520	60.5	V	74.0	-13.5	PK	93	1.0	RB 1 MHz;VB 3 MHz;Pk	50
2779.520	52.5	V	54.0	-1.5	AVG	93	1.0	RB 1 MHz;VB 10 Hz;Pk	50
3705.980	44.4	V	54.0	-9.6	AVG	286	1.6	RB 1 MHz;VB 10 Hz;Pk	50
3707.320	52.4	V	74.0	-21.6	PK	286	1.6	RB 1 MHz;VB 3 MHz;Pk	50
4632.480	35.2	V	54.0	-18.8	AVG	112	1.3	RB 1 MHz;VB 10 Hz;Pk	50
4632.680	43.2	V	74.0	-30.8	PK	112	1.3	RB 1 MHz;VB 3 MHz;Pk	50
5558.900	43.1	V	54.0	-10.9	AVG	172	1.3	RB 1 MHz;VB 10 Hz;Pk	50
5559.050	51.1	V	74.0	-22.9	PK	172	1.3	RB 1 MHz;VB 3 MHz;Pk	50
7412.020	37.6	V	54.0	-16.4	AVG	103	1.9	RB 1 MHz;VB 10 Hz;Pk	50
7413.250	45.6	V	74.0	-28.4	PK	103	1.9	RB 1 MHz;VB 3 MHz;Pk	50

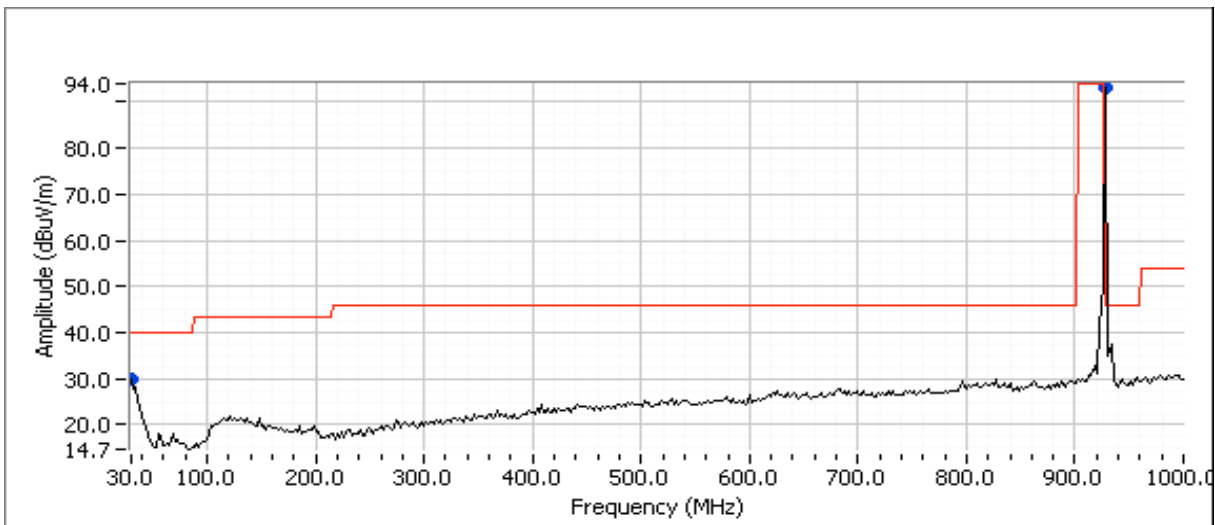

Client:	Control Chief	Job Number:	J85385
Model:	Sesam 800	T-Log Number:	T85509
Contact:	Jake Byner	Account Manager:	Susan Pelzl
Standard:	FCC 15.249, RSS-210	Class:	-

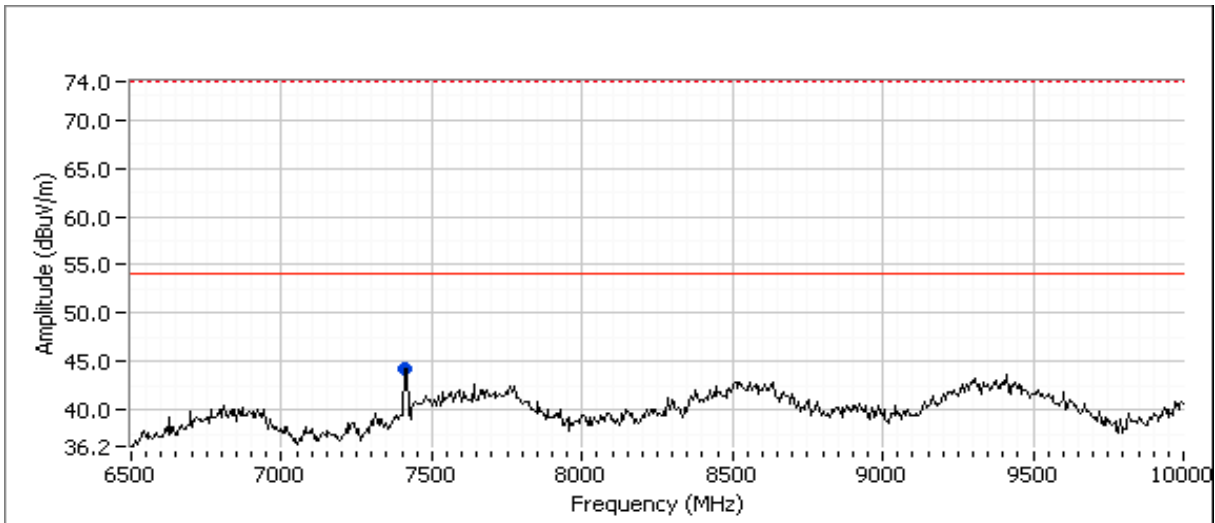
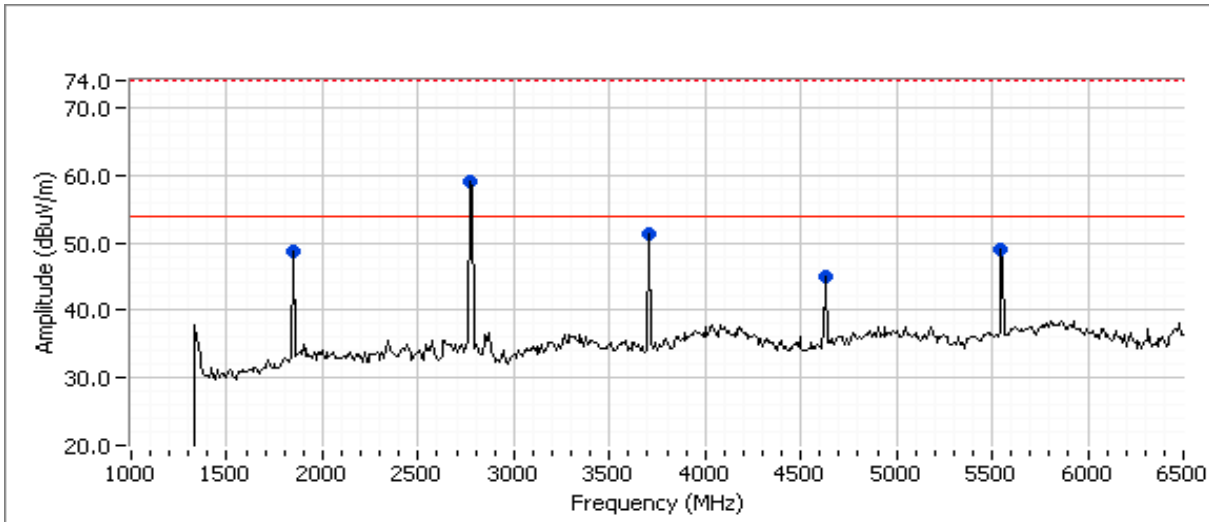

Note 1: The average values are calculated from the peak level less 8dB duty cycle correction factor (40% duty cycle)

Client:	Control Chief	Job Number:	J85385
Model:	Sesam 800	T-Log Number:	T85509
Contact:	Jake Byner	Account Manager:	Susan Pelzl
Standard:	FCC 15.249, RSS-210	Class:	-

Run #1c: Radiated Emissions, 30 - 10,000 MHz (Sesam 800 L99 - transmit mode) UPRIGHT

Fundamental Frequency

Frequency MHz	Level dB μ V/m	Pol v/h	FCC 15.249		Detector Pk/QP/Avg	Azimuth degrees	Height meters	Comments	
			Limit	Margin					Setting
926.501	93.4	H	94.0	-0.6	QP	355	1.0	QP (1.00s)	50
929.897	89.4	V	94.0	-4.6	QP	257	1.0	QP (1.00s)	50

Spurious emission

Frequency MHz	Level dB μ V/m	Pol v/h	FCC 15.249		Detector Pk/QP/Avg	Azimuth degrees	Height meters	Comments	
			Limit	Margin					Setting
30.875	23.7	V	40.0	-16.3	QP	296	4.0	QP (1.00s)	50
902.000	26.2	V	46.0	-19.8	QP	72	1.5	QP (1.00s)	50
928.000	27.6	V	46.0	-18.4	QP	291	1.0	QP (1.00s)	50
1853.020	43.6	V	54.0	-10.4	AVG	44	1.0	RB 1 MHz;VB 10 Hz;Pk	50
1853.180	51.6	V	74.0	-22.4	PK	44	1.0	RB 1 MHz;VB 3 MHz;Pk	50
2779.520	51.2	V	54.0	-2.8	AVG	78	1.6	RB 1 MHz;VB 10 Hz;Pk	50
2780.670	59.2	V	74.0	-14.8	PK	78	1.6	RB 1 MHz;VB 3 MHz;Pk	50
3705.990	52.2	V	74.0	-21.8	PK	304	1.6	RB 1 MHz;VB 3 MHz;Pk	50
3706.000	44.2	V	54.0	-9.8	AVG	304	1.6	RB 1 MHz;VB 10 Hz;Pk	50
5559.020	44.4	H	54.0	-9.6	AVG	142	1.6	RB 1 MHz;VB 10 Hz;Pk	50
5559.270	52.4	H	74.0	-21.6	PK	142	1.6	RB 1 MHz;VB 3 MHz;Pk	50
7410.900	46.1	H	74.0	-27.9	PK	92	1.3	RB 1 MHz;VB 3 MHz;Pk	50
7412.040	38.1	H	54.0	-15.9	AVG	92	1.3	RB 1 MHz;VB 10 Hz;Pk	50

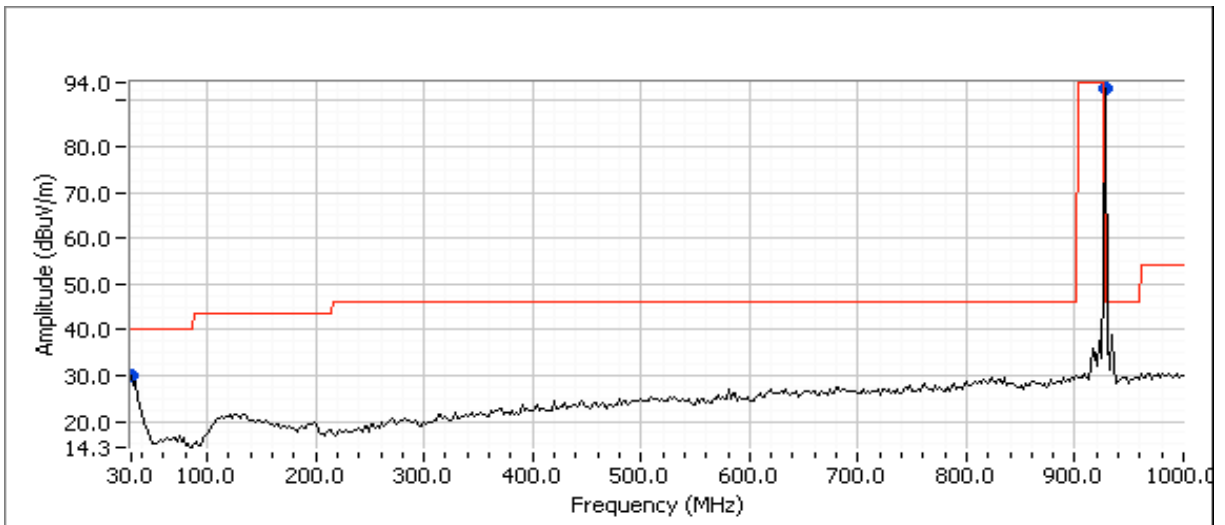

Client:	Control Chief	Job Number:	J85385
Model:	Sesam 800	T-Log Number:	T85509
Contact:	Jake Byner	Account Manager:	Susan Pelzl
Standard:	FCC 15.249, RSS-210	Class:	-

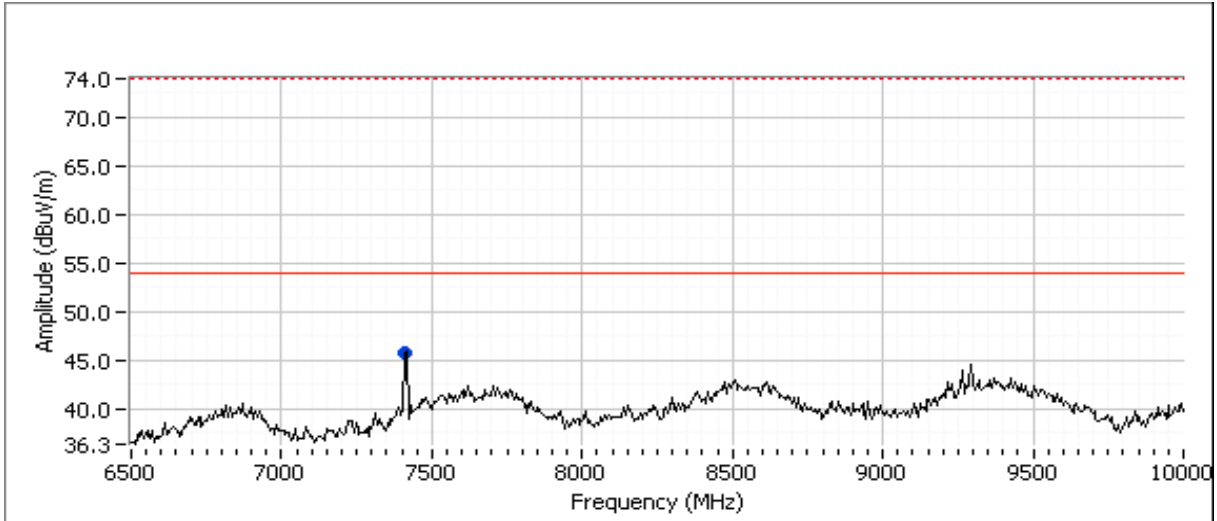
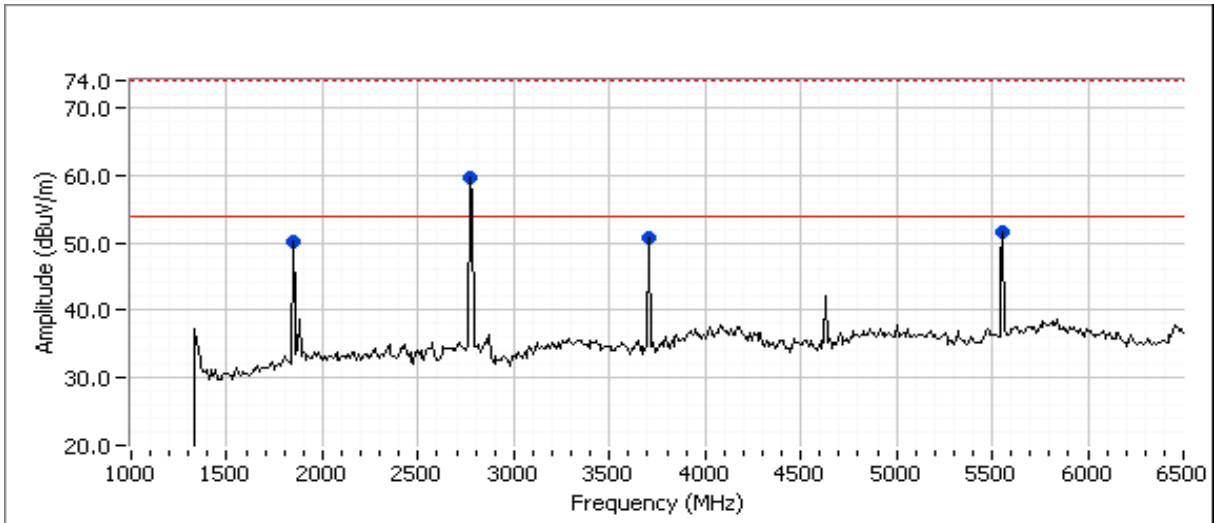

Note 1: The average values are calculated from the peak level less 8dB duty cycle correction factor (40% duty cycle)

Client:	Control Chief	Job Number:	J85385
Model:	Sesam 800	T-Log Number:	T85509
Contact:	Jake Byner	Account Manager:	Susan Pelzl
Standard:	FCC 15.249, RSS-210	Class:	-

Run #2: Radiated Emissions, 30 - 3,000 MHz (Sesam 800 L99 Receive mode)
 Test Engineer: M. Birgani EUT Voltage: 120V, 60Hz

Other Spurious Emissions

Frequency	Level	Pol	15.109		Detector	Azimuth	Height	Comments
MHz	dB μ V/m	V/H	Limit	Margin	Pk/QP/Avg	degrees	meters	
30.000	19.8	H	40.0	-20.2	Peak	252	1.0	Peak reading with QP limit
54.250	19.6	V	40.0	-20.4	Peak	278	1.5	Peak reading with QP limit

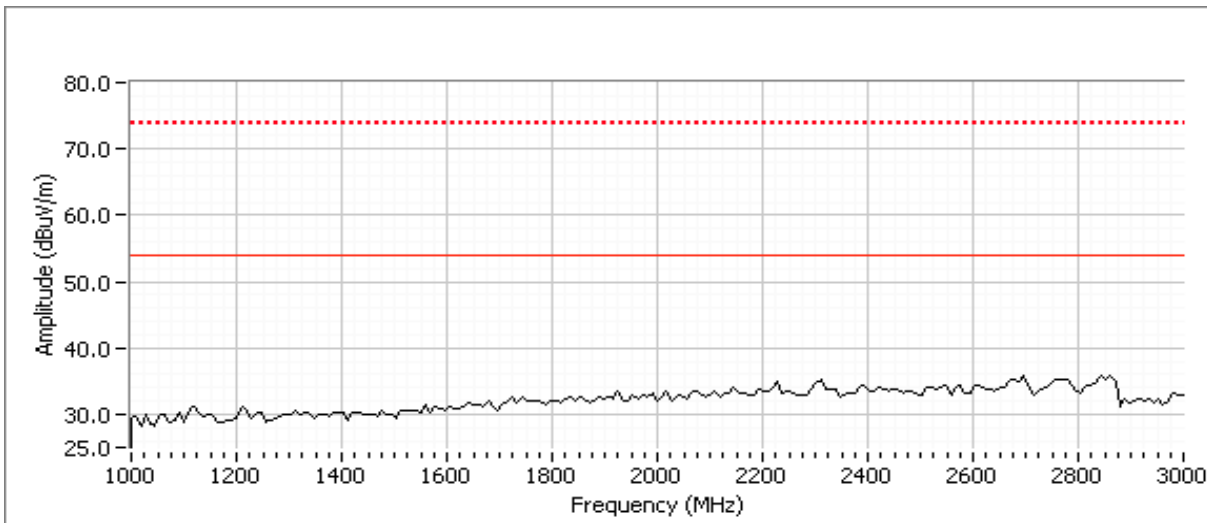
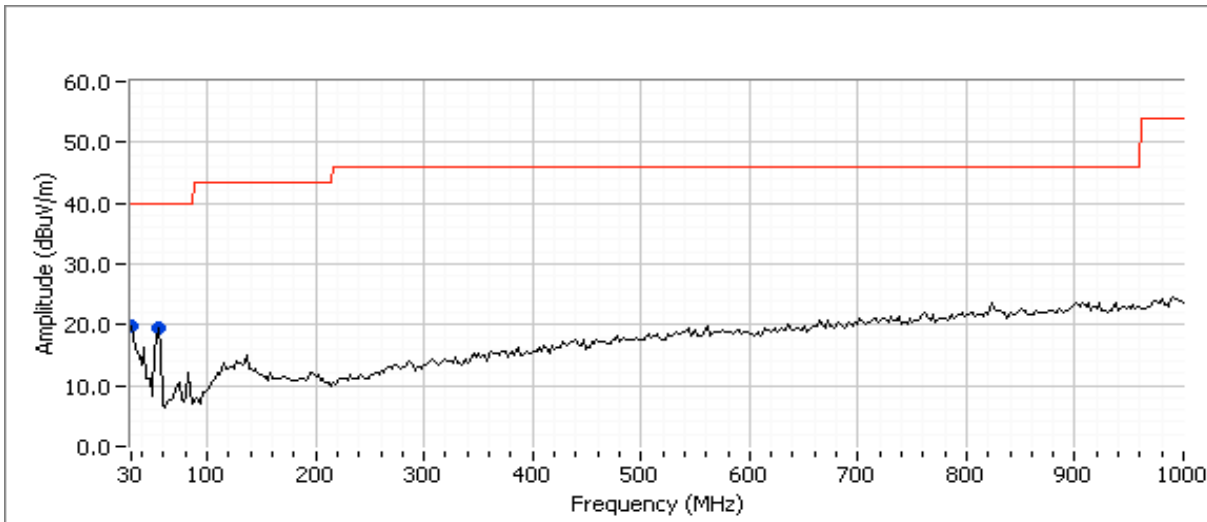

Client:	Control Chief	Job Number:	J85385
Model:	Sesam 800	T-Log Number:	T85509
Contact:	Jake Byner	Account Manager:	Susan Pelzl
Standard:	FCC 15.249, RSS-210	Class:	-

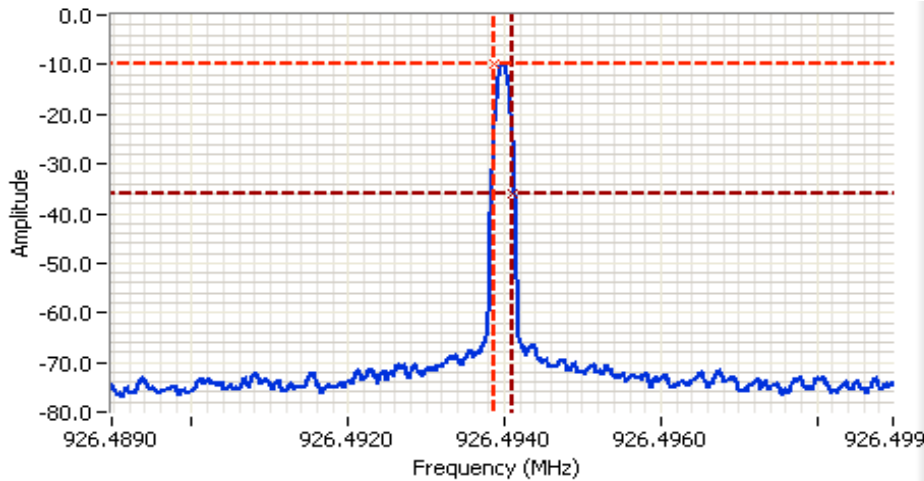

Analyzer Settings

Agilent Technologies, E4446A
 CF: 926.494 MHz
 SPAN: 10.0 kHz
 RB: 100 Hz
 VB: 300 Hz
 Detector: POS
 Attn: 10 DB
 RL Offset: 0.0 DB
 Sweep Time: 111.4ms
 Ref Lvl: -3.0 DBM

Comments

99% BW: 240 Hz

Cursor 1 926.4939 -9.91   

Cursor 2 926.4941 -35.91   

Delta Freq. 240 Hz

Delta Amplitude 26.00

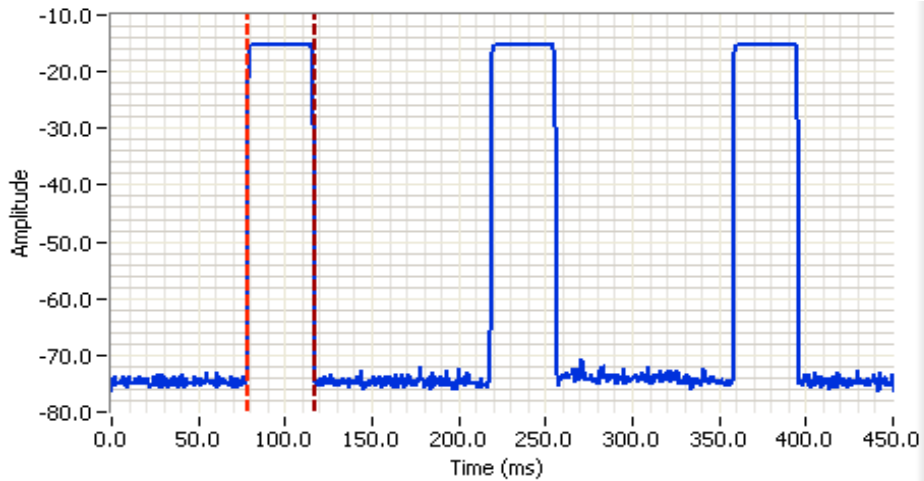

Analyzer Settings

Agilent Technologies, E4446A
 CF: 926.496 MHz
 SPAN: 0.000 MHz
 RB: 1.000 MHz
 VB: 1.000 MHz
 Detector: POS
 Attn: 10 DB
 RL Offset: 0.0 DB
 Sweep Time: 0.5s
 Ref Lvl: -13.0 DBM

Comments

Duty Cycle
 On time: 38.7 ms

Cursor 1 78.5156 0.00   

Cursor 2 117.1875 0.00   

Delta Time (ms) 38.67

Delta Amplitude 0.00



End of Report

This page is intentionally blank and marks the last page of this test report.